



Instruction Manual

VLT[®] AutomationDrive FC 301/302

0.25–75 kW



Contents

1 Introduction	4
1.1 Purpose of the Manual	4
1.2 Additional Resources	4
1.3 Document and Software Version	4
1.4 Product Overview	4
1.5 Enclosure Types and Power Ratings	7
1.6 Approvals and Certifications	7
1.7 Disposal Instruction	7
2 Safety	8
2.1 Safety Symbols	8
2.2 Qualified Personnel	8
2.3 Safety Precautions	8
3 Mechanical Installation	10
3.1 Unpacking	10
3.2 Installation Environments	10
3.3 Mounting	11
4 Electrical Installation	12
4.1 Safety Instructions	12
4.2 EMC-compliant Installation	12
4.3 Grounding	12
4.4 Wiring Schematic	13
4.5 Access	15
4.6 Motor Connection	15
4.7 AC Line Input Connection	16
4.8 Control Wiring	16
4.8.1 Control Terminal Types	17
4.8.2 Wiring to Control Terminals	18
4.8.3 Enabling Motor Operation (Terminal 27)	19
4.8.4 Voltage/Current Input Selection (Switches)	19
4.8.5 Safe Torque Off (STO)	19
4.8.6 Mechanical Brake Control	19
4.8.7 RS-485 Serial Communication	20
4.9 Installation Check List	21
5 Commissioning	22

5.1 Safety Instructions	22
5.2 Applying Power	22
5.3 Local Control Panel Operation	23
5.4 Basic Programming	26
5.4.1 Commissioning with SmartStart	26
5.4.2 Commissioning via [Main Menu]	26
5.4.3 Asynchronous Motor Set-up	27
5.4.4 PM Motor Set-up in VVC ^{plus}	27
5.4.5 Automatic Motor Adaptation (AMA)	29
5.5 Checking Motor Rotation	29
5.6 Checking Encoder Rotation	29
5.7 Local Control Test	30
5.8 System Start-up	30
6 Application Set-up Examples	31
7 Diagnostics and Troubleshooting	37
7.1 Maintenance and Service	37
7.2 Status Messages	37
7.3 Warning and Alarm Types	39
7.4 List of Warnings and Alarms	40
7.5 Troubleshooting	49
8 Specifications	51
8.1 Electrical Data	51
8.1.1 Line Power Supply 3x200–240 V AC	51
8.1.2 Line Power Supply 3x380–500 V AC	54
8.1.3 Line Power Supply 3x525–600 V AC (FC 302 only)	57
8.1.4 Line Power Supply 3x525–690 V AC (FC 302 only)	60
8.2 Line Power Supply	63
8.3 Motor Output and Motor Data	63
8.4 Ambient Conditions	64
8.5 Cable Specifications	64
8.6 Control Input/Output and Control Data	65
8.7 Fuses and Circuit Breakers	69
8.8 Connection Tightening Torques	76
8.9 Power Ratings, Weight and Dimensions	77
9 Appendix	79
9.1 Symbols, Abbreviations and Conventions	79

9.2 Parameter Menu Structure	79
Index	85

1 Introduction

1.1 Purpose of the Manual

This instruction manual provides information for safe installation and commissioning of the adjustable frequency drive.

This instruction manual is intended for use by qualified personnel.

Read and follow the instruction manual to use the adjustable frequency drive safely and professionally, and pay particular attention to the safety instructions and general warnings. Keep this instruction manual available with the adjustable frequency drive at all times.

1.2 Additional Resources

Other resources are available to understand advanced adjustable frequency drive functions and programming.

- The *Programming Guide* provides greater detail on working with parameters and many application examples.
- The *Design Guide* provides detailed information about capabilities and functionality to design motor control systems.
- Instructions for operation with optional equipment.

Disclosure, duplication and sale of this document, as well as communication of its content, are prohibited unless explicitly permitted. Infringement of this prohibition incurs liability for damages. All rights reserved with regard to patents, utility patents and registered designs.

1.3 Document and Software Version

This manual is regularly reviewed and updated. All suggestions for improvement are welcome. *Table 1.1* shows the document version and the corresponding software version.

Edition	Remarks	Software version
MG33ANxx	Replaces MG33AMxx	6.72

Table 1.1 Document and Software Version

1.4 Product Overview

1.4.1 Intended Use

The adjustable frequency drive is an electronic motor controller intended for

- regulation of motor speed in response to system feedback or to remote commands from external controllers. A power drive system consists of the adjustable frequency drive, the motor and equipment driven by the motor.
- system and motor status surveillance.

The adjustable frequency drive can also be used for motor protection.

Depending on configuration, the adjustable frequency drive can be used in standalone applications or form part of a larger appliance or installation.

The adjustable frequency drive is allowed for use in residential, industrial and commercial environments in accordance with local laws and standards.

NOTICE!

In a residential environment, this product can cause radio interference, in which case supplementary mitigation measures can be required.

Foreseeable misuse

Do not use the adjustable frequency drive in applications which are non-compliant with specified operating conditions and environments. Ensure compliance with the conditions specified in *chapter 8 Specifications*.

1.4.2 Exploded Views

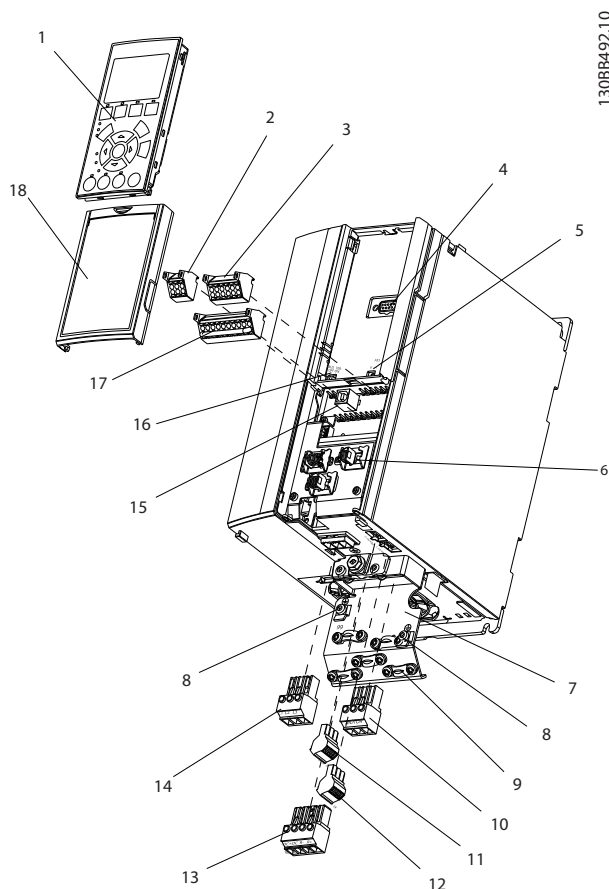

Figure 1.1 Exploded View Enclosure Type A, IP20

1	Local control panel (LCP)	10	Motor output terminals 96 (U), 97 (V), 98 (W)
2	RS-485 serial bus connector (+68, -69)	11	Relay 2 (01, 02, 03)
3	Analog I/O connector	12	Relay 1 (04, 05, 06)
4	LCP input plug	13	Brake (-81, +82) and load sharing (-88, +89) terminals
5	Analog switches (A53), (A54)	14	Line power input terminals 91 (L1), 92 (L2), 93 (L3)
6	Cable shield connector	15	USB connector
7	Decoupling plate	16	Serial bus terminal switch
8	Grounding clamp (PE)	17	Digital I/O and 24 V power supply
9	Shielded cable grounding clamp and strain relief	18	Cover

Table 1.2 Legend to Figure 1.1

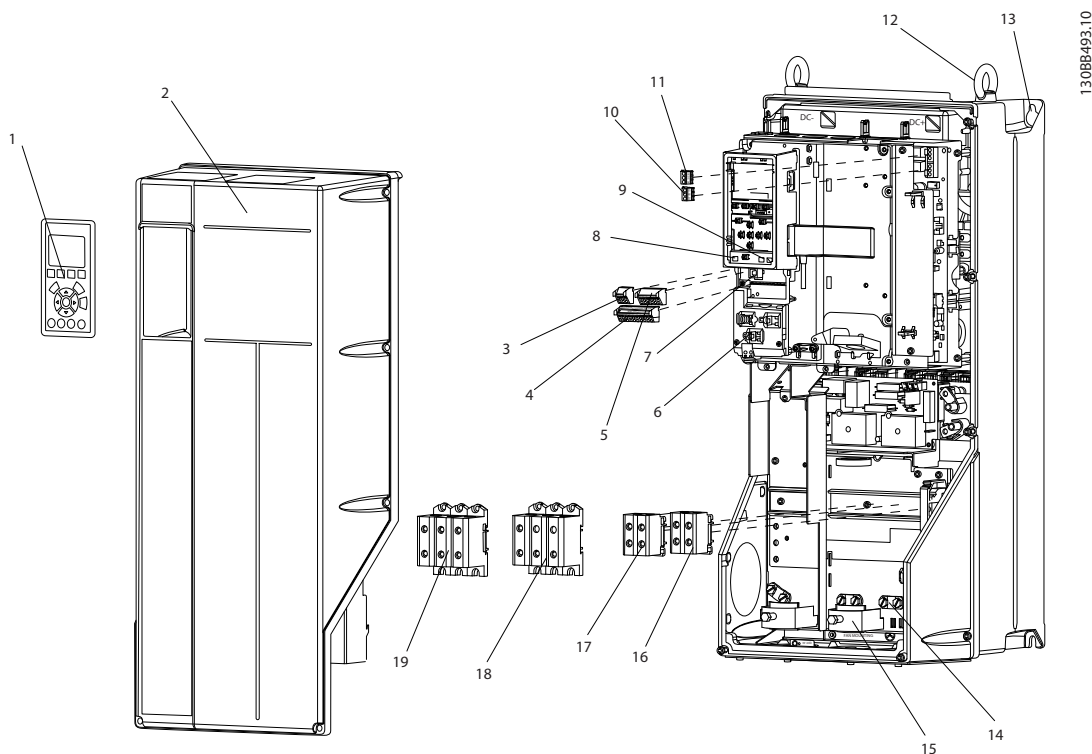

Figure 1.2 Exploded View Enclosure Types B and C, IP55 and IP66

1	Local control panel (LCP)	11	Relay 2 (04, 05, 06)
2	Cover	12	Lifting ring
3	RS-485 serial bus connector	13	Mounting slot
4	Digital I/O and 24 V power supply	14	Grounding clamp (PE)
5	Analog I/O connector	15	Cable shield connector
6	Cable shield connector	16	Brake terminal (-81, +82)
7	USB connector	17	Load sharing terminal (DC bus) (-88, +89)
8	Serial bus terminal switch	18	Motor output terminals 96 (U), 97 (V), 98 (W)
9	Analog switches (A53), (A54)	19	Line power input terminals 91 (L1), 92 (L2), 93 (L3)
10	Relay 1 (01, 02, 03)		

Table 1.3 Legend to Figure 1.2

1.4.3 Block Diagram of the Adjustable Frequency Drive

Figure 1.3 is a block diagram of the adjustable frequency drive's internal components. See Table 1.4 for their functions.

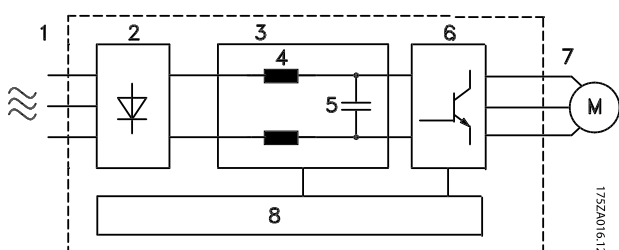

Figure 1.3 Adjustable Frequency Drive Block Diagram

Area	Title	Functions
8	Control circuitry	<ul style="list-style-type: none"> Input power, internal processing, output, and motor current are monitored to provide efficient operation and control User interface and external commands are monitored and performed Status output and control can be provided

Table 1.4 Legend to Figure 1.3

Area	Title	Functions
1	Line power input	<ul style="list-style-type: none"> 3-phase AC line power supply to the adjustable frequency drive
2	Rectifier	<ul style="list-style-type: none"> The rectifier bridge converts the AC input to DC current to supply inverter power
3	DC bus	<ul style="list-style-type: none"> Intermediate DC bus circuit handles the DC current
4	DC reactors	<ul style="list-style-type: none"> Filter the intermediate DC circuit voltage Provide line transient protection Reduce RMS current Raise the power factor reflected back to the line Reduce harmonics on the AC input
5	Capacitor bank	<ul style="list-style-type: none"> Stores the DC power Provides ride-through protection for short power losses
6	Inverter	<ul style="list-style-type: none"> Converts the DC into a controlled PWM AC waveform for a controlled variable output to the motor
7	Output to motor	<ul style="list-style-type: none"> Regulated 3-phase output power to the motor

1.5 Enclosure Types and Power Ratings

For enclosure types and power ratings of the adjustable frequency drives, refer to *chapter 8.9 Power Ratings, Weight and Dimensions*.

1.6 Approvals and Certifications



Table 1.5 Approvals and Certifications

More approvals and certifications are available. Contact local Danfoss partner. The T7 (525–690 V) adjustable frequency drives are not certified for UL.

The adjustable frequency drive complies with UL508C thermal memory retention requirements. For more information, refer to the section *Motor Thermal Protection* in the *Design Guide*.

1.7 Disposal Instruction

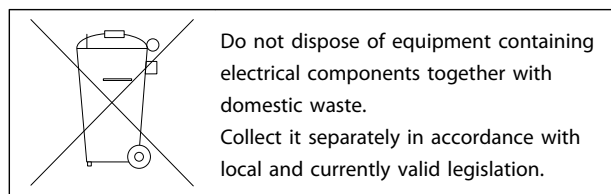

Table 1.6 Disposal Instruction

2

2 Safety

2.1 Safety Symbols

The following symbols are used in this document.

⚠ WARNING

Indicates a potentially hazardous situation which could result in death or serious injury.

⚠ CAUTION

Indicates a potentially hazardous situation which could result in minor or moderate injury. It may also be used to alert against unsafe practices.

NOTICE

Indicates important information, including situations that may result in damage to equipment or property.

2.2 Qualified Personnel

Correct and reliable transport, storage, installation, operation and maintenance are required for the trouble-free and safe operation of the adjustable frequency drive. Only qualified personnel is allowed to install or operate this equipment.

Qualified personnel is defined as trained staff, who are authorized to install, commission, and maintain equipment, systems and circuits in accordance with pertinent laws and regulations. Additionally, the personnel must be familiar with the instructions and safety measures described in this document.

2.3 Safety Precautions

⚠ WARNING

HIGH VOLTAGE!

Adjustable frequency drives contain high voltage when connected to AC line input power. Installation, start-up, and maintenance must be performed by qualified personnel only. Failure to perform installation, start-up, and maintenance by qualified personnel could result in death or serious injury.

⚠ WARNING

UNINTENDED START!

When the adjustable frequency drive is connected to AC line power, the motor may start at any time. The adjustable frequency drive, motor, and any driven equipment must be in operational readiness. Failure to be in operational readiness when the adjustable frequency drive is connected to AC line power could result in death, serious injury, equipment or property damage.

⚠WARNING

DISCHARGE TIME!

Adjustable frequency drives contain DC link capacitors that can remain charged even when the adjustable frequency drive is not powered. To avoid electrical hazards, disconnect AC line power, any permanent magnet type motors, and any remote DC link power supplies, including battery backups, UPS and DC link connections to other adjustable frequency drives. Wait for the capacitors to discharge completely before performing any service or repair work. The amount of waiting time is listed in *Table 2.1*. Failure to wait the specified time after power has been removed before doing service or repair could result in death or serious injury.

Voltage [V]	Minimum waiting time [minutes]		
	4	7	15
200–240	0.34–5 hp [0.25–3.7 kW]		7.5–50 hp [5.5–37 kW]
380–500	0.34–10 hp [0.25–7.5 kW]		15–100 hp [11–75 kW]
525–600	1–10 hp [0.75–7.5 kW]		15–100 hp [11–75 kW]
525–690		2–10 hp [1.5–7.5 kW]	15–100 hp [11–75 kW]

High voltage may be present even when the warning LED indicator lights are off.

Table 2.1 Discharge Time

⚠WARNING

LEAKAGE CURRENT HAZARD!

Leakage currents are higher than 3.5 mA. It is the responsibility of the user or certified electrical installer to ensure correct grounding of the equipment. Failure to ground the adjustable frequency drive properly could result in death or serious injury.

⚠WARNING

EQUIPMENT HAZARD!

Rotating shafts and electrical equipment can be hazardous. All electrical work must conform to national and local electrical codes. Installation, start-up, and maintenance are performed only by trained and qualified personnel. Failure to follow these guidelines could result in death or serious injury.

⚠WARNING

WINDMILLING!

Unintended rotation of permanent magnet motors causes a risk of personal injury and equipment damage. Ensure permanent magnet motors are blocked to prevent unintended rotation.

⚠CAUTION

POTENTIAL HAZARD IN THE EVENT OF INTERNAL FAILURE!

Risk of personal injury when the adjustable frequency drive is not properly closed. Before applying power, ensure all safety covers are in place and securely fastened.

3 Mechanical Installation

3

3.1 Unpacking

3.1.1 Items Supplied

Items supplied may vary according to product configuration.

- Make sure the items supplied and the information on the nameplate correspond to the order confirmation.
- Check the packaging and the adjustable frequency drive visually for damage caused by inappropriate handling during shipment. File any claim for damage with the carrier. Retain damaged parts for clarification.

NOTICE!

Do not remove the nameplate from the adjustable frequency drive (loss of warranty).

3.1.2 Storage

Ensure that requirements for storage are fulfilled. Refer to *chapter 8.4 Ambient Conditions* for further details.

3.2 Installation Environments

NOTICE!

In environments with airborne liquids, particles, or corrosive gases, ensure that the IP/Type rating of the equipment matches the installation environment. Failure to meet requirements for ambient conditions can reduce lifetime of the adjustable frequency drive. Ensure that requirements for air humidity, temperature and altitude are met.

Vibration and Shock

The adjustable frequency drive complies with requirements for units mounted on the walls and floors of production premises, as well as in panels bolted to walls or floors.

For detailed ambient conditions specifications, refer to *chapter 8.4 Ambient Conditions*.

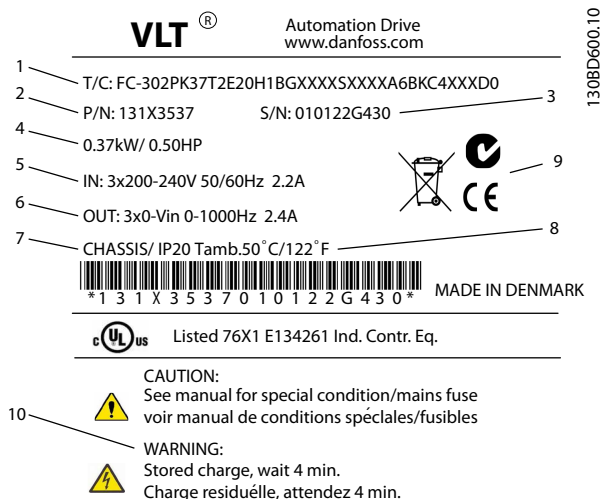

Figure 3.1 Product Nameplate (Example)

1	Type code
2	Order number
3	Serial number
4	Power rating
5	Input voltage, frequency and current (at low/high voltages)
6	Output voltage, frequency and current (at low/high voltages)
7	Enclosure type and IP rating
8	Maximum ambient temperature
9	Certifications
10	Discharge time (Warning)

Table 3.1 Legend to Figure 3.1

3.3 Mounting

NOTICE!

Improper mounting can result in overheating and reduced performance.

Cooling

- Ensure that top and bottom clearance for air cooling is provided. See *Figure 3.2* for clearance requirements.

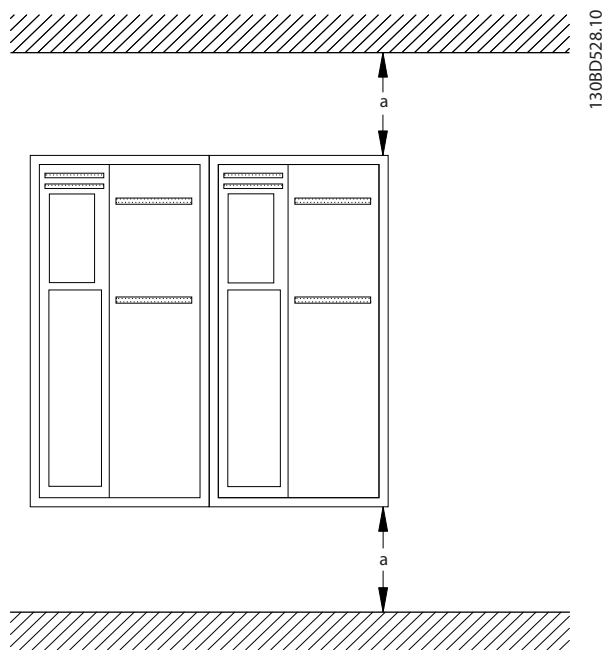

Figure 3.2 Top and Bottom Cooling Clearance

Enclosure	A1-A5	B1-B4	C1, C3	C2, C4
a (ins [mm])	4 [100]	8 [200]	8 [200]	9 [225]

Table 3.2 Minimum Airflow Clearance Requirements

Lifting

- To determine a safe lifting method, check the weight of the unit, see *chapter 8.9 Power Ratings, Weight and Dimensions*.
- Ensure that the lifting device is suitable for the task.
- If necessary, plan for a hoist, crane, or forklift with the appropriate rating to move the unit.
- For lifting, use hoist rings on the unit, when provided.

Mounting

1. Ensure that the strength of the mounting location supports the unit weight. The adjustable frequency drive allows side-by-side installation.
2. Locate the unit as near to the motor as possible. Keep the motor cables as short as possible.
3. Mount the unit vertically on a solid flat surface or on the optional backplate.
4. Use the slotted mounting holes on the unit for wall mounting, when provided.

Mounting with backplate and railings

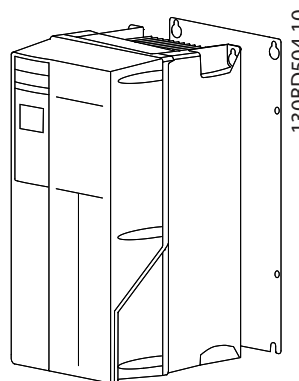

Figure 3.3 Proper Mounting with Backplate

NOTICE!

Backplate is required when mounted on railings.

4 Electrical Installation

4.1 Safety Instructions

See *chapter 2 Safety* for general safety instructions.

⚠ WARNING

INDUCED VOLTAGE!

Induced voltage from output motor cables that run together can charge equipment capacitors even with the equipment turned off and locked out. Failure to run output motor cables separately or use shielded cables or metal conduits could result in death or serious injury.

⚠ CAUTION

DC CURRENT HAZARD!

A DC current in the protective grounding conductor can be caused by the adjustable frequency drives. When a residual current-operated protective or monitoring device (RCD/RCM) is used for protection, only an RCD or RCM of Type B is allowed.

NOTICE!

The adjustable frequency drive is supplied with Class 20 motor overload protection.

Overcurrent Protection:

- Additional protective equipment such as short-circuit protection or motor thermal protection between adjustable frequency drive and motor is required for applications with multiple motors.
- Input fusing is required to provide short-circuit and overcurrent protection. If not factory-supplied, fuses must be provided by the installer. See maximum fuse ratings in *chapter 8.7 Fuses and Circuit Breakers*.

Wire Type and Ratings

- All wiring must comply with local and national regulations regarding cross-section and ambient temperature requirements.
- Power connection wire recommendation: minimum 167 °F [75 °C] rated copper wire.

See *chapter 8.1 Electrical Data* and *chapter 8.5 Cable Specifications* for recommended wire sizes and types.

4.2 EMC-compliant Installation

To obtain an EMC-compliant installation, follow the instructions provided in *chapter 4.3 Grounding*, *chapter 4.4 Wiring Schematic*, *chapter 4.6 Motor Connection*, and *chapter 4.8 Control Wiring*.

4.3 Grounding

⚠ WARNING

LEAKAGE CURRENT HAZARD!

Leakage currents are higher than 3.5 mA. It is the responsibility of the user or certified electrical installer to ensure correct grounding of the equipment. Failure to ground the adjustable frequency drive properly could result in death or serious injury.

For electrical safety

- Ground the adjustable frequency drive properly in accordance with applicable standards and directives.
- Use a dedicated ground wire for input power, motor power and control wiring.
- Do not ground one adjustable frequency drive to another in a "daisy chain" fashion.
- Keep the ground wire connections as short as possible.
- Follow the motor manufacturer wiring requirements.
- Minimum cable cross-section: 0.016 in² [10 mm²] (or 2 rated ground wires terminated separately).

For EMC-compliant installation

- Establish electrical contact between cable shield and adjustable frequency drive enclosure by using metal cable connectors or by using the clamps provided on the equipment (see *Figure 4.5* and *Figure 4.6*).
- Use high-strand wire to reduce electrical interference.
- Do not use pigtails.

NOTICE!
POTENTIAL EQUALIZATION!

Electrical interference risks disturbing the entire installation when the ground potential between the adjustable frequency drive and the system is different. To avoid electrical interference, install equalizing cables between the system components. Recommended cable cross-section: 0.025² [16 mm²].

4.4 Wiring Schematic

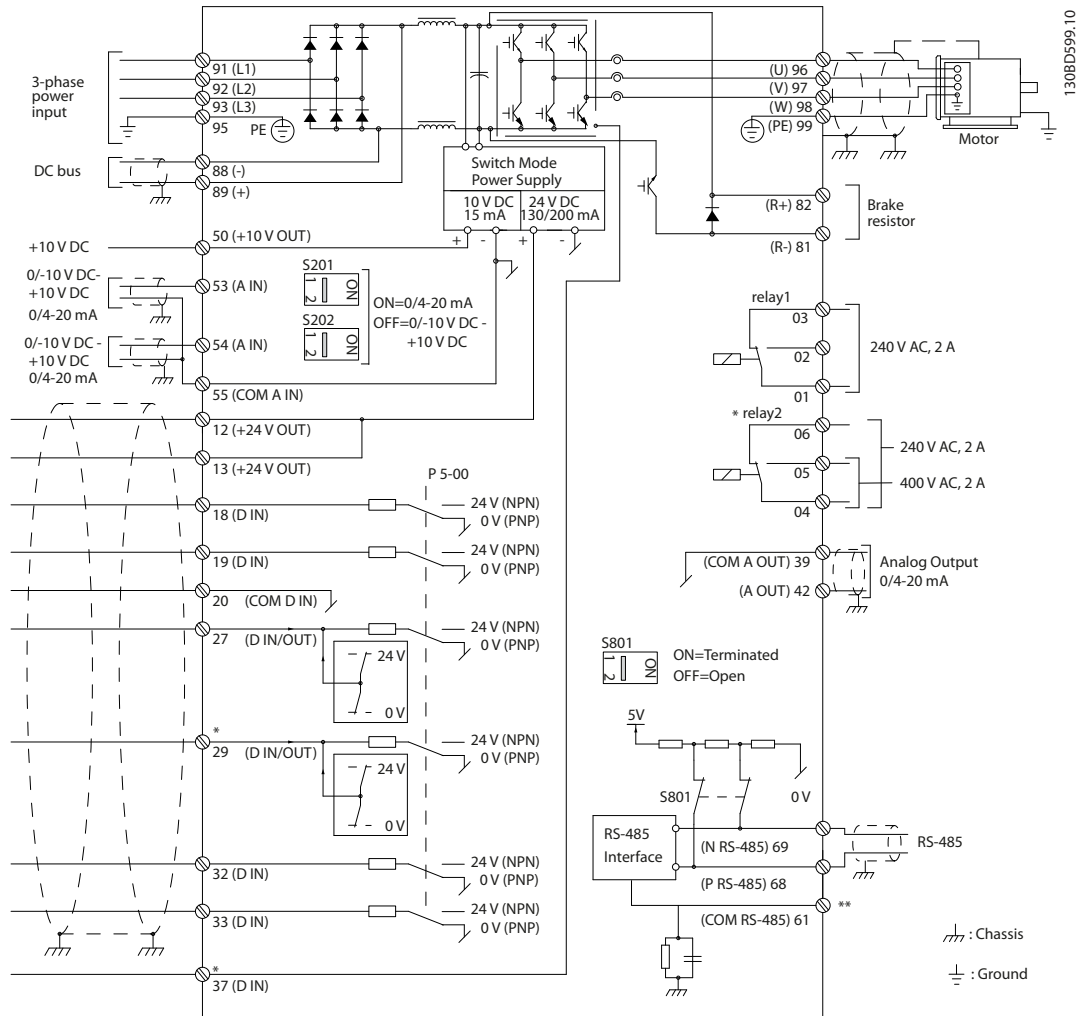
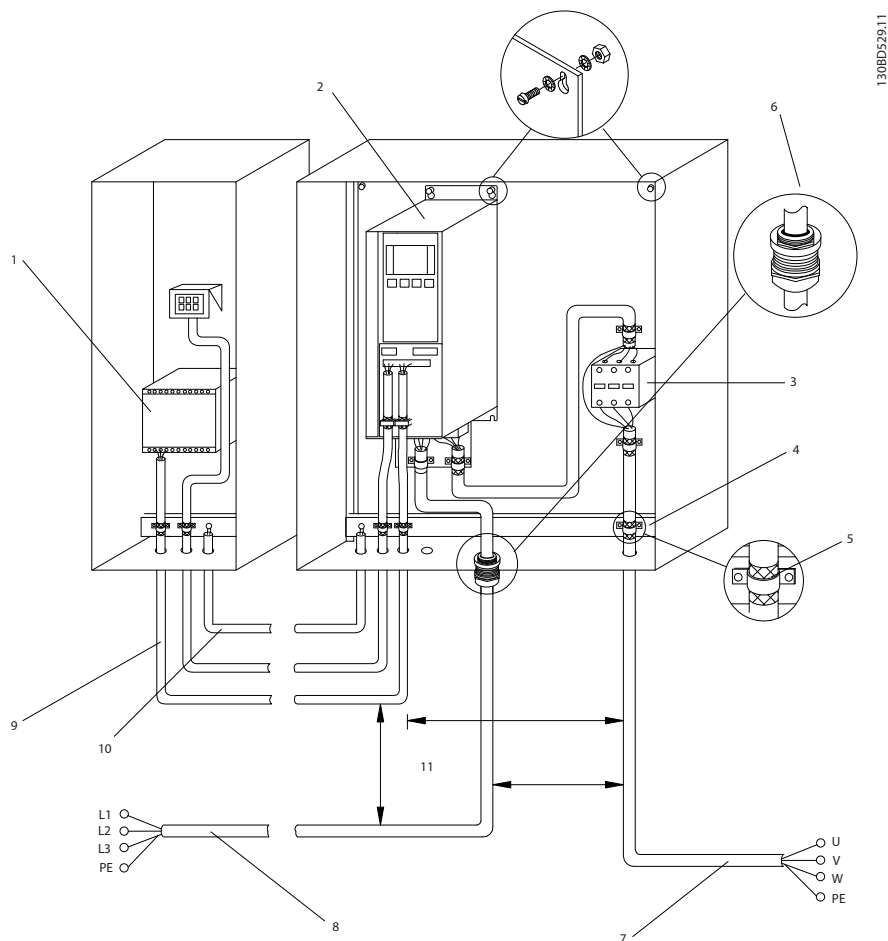

Figure 4.1 Basic Wiring Schematic

A=Analog, D=Digital

*Terminal 37 (optional) is used for Safe Torque Off. For Safe Torque Off installation instructions, refer to the *Safe Torque Off Instruction Manual for Danfoss VLT® Adjustable Frequency Drives*. Terminal 37 is not included in FC 301 (except enclosure type A1). Relay 2 and terminal 29 have no function in FC 301.

**Do not connect cable shield.



130BD52911

Figure 4.2 EMC-compliant Electrical Connection

1	PLC	6	Cable connector
2	Adjustable frequency drive	7	Motor, 3-phase and PE (shielded)
3	Output contactor	8	Line power, 3-phase and reinforced PE (non-shielded)
4	Cable clamp	9	Control wiring (shielded)
5	Cable insulation (stripped)	10	Potential equalization min. 16 mm ² (0.025 in ²)

Table 4.1 Legend to Figure 4.2

NOTICE!

EMC INTERFERENCE!

Run cables for input power, motor wiring and control wiring in three separate metallic conduits. Failure to isolate power, motor and control cables can result in unintended behavior or reduced performance. Minimum 200 mm (8 in) clearance between power, motor and control cables.

4.5 Access

- Remove cover with a screwdriver (See Figure 4.3) or by loosening attaching screws (See Figure 4.4).

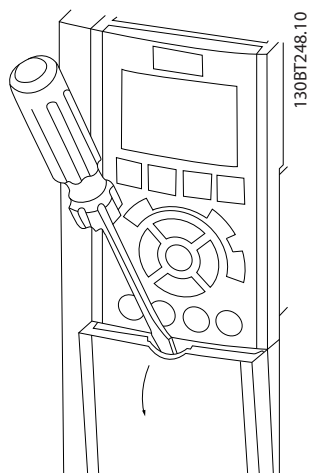

Figure 4.3 Access to Wiring for IP20 and IP21 Enclosures

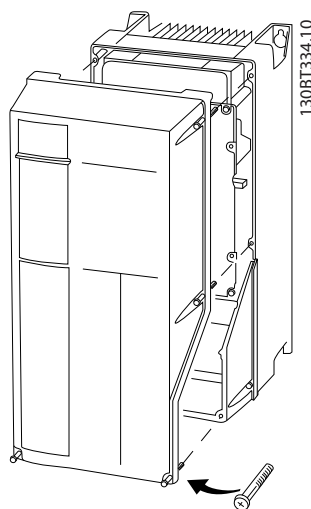

Figure 4.4 Access to Wiring for IP55 and IP66 Enclosures

See Table 4.2 before tightening covers.

Enclosure	IP55	IP66
A4/A5	2	2
B1/B2	2.2	2.2
C1/C2	2.2	2.2
No screws to tighten for A1/A2/A3/B3/B4/C3/C4.		

Table 4.2 Tightening Torques for Covers [Nm]

4.6 Motor Connection

WARNING

INDUCED VOLTAGE!

Induced voltage from output motor cables that run together can charge equipment capacitors even with the equipment turned off and locked out. Failure to run output motor cables separately or use shielded cables or metal conduits could result in death or serious injury.

- Comply with local and national electrical codes for cable sizes. For maximum wire sizes, see *chapter 8.1 Electrical Data*.
- Follow the motor manufacturer wiring requirements.
- Motor wiring knockouts or access panels are provided at the base of IP21 (NEMA1/12) and higher units.
- Do not wire a starting or pole-changing device (e.g., Dahlander motor or slip ring induction motor) between the adjustable frequency drive and the motor.

Procedure

- Strip a section of the outer cable insulation.
- Position the stripped wire under the cable clamp to establish mechanical fixation and electrical contact between cable shield and ground.
- Connect ground wire to the nearest grounding terminal in accordance with grounding instructions provided in *chapter 4.3 Grounding*, see *Figure 4.5*.
- Connect the 3-phase motor wiring to terminals 96 (U), 97 (V), and 98 (W), see *Figure 4.5*.
- Tighten terminals in accordance with the information provided in *chapter 8.8 Connection Tightening Torques*.

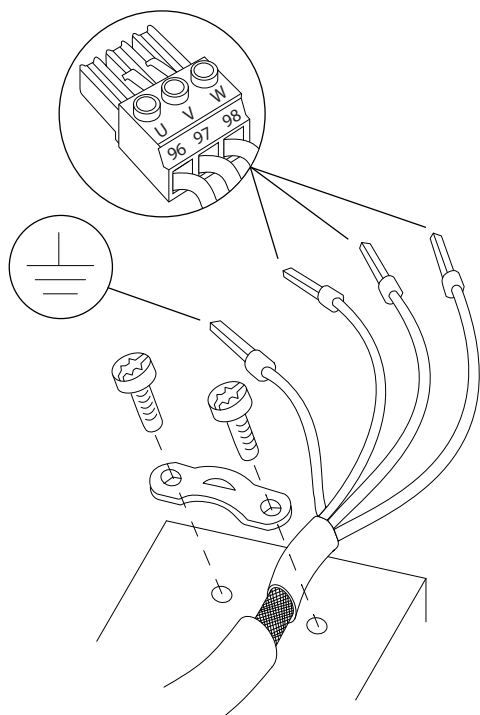

Figure 4.5 Motor Connection

Figure 4.6 represents line power input, motor, and grounding for basic adjustable frequency drives. Actual configurations vary with unit types and optional equipment.

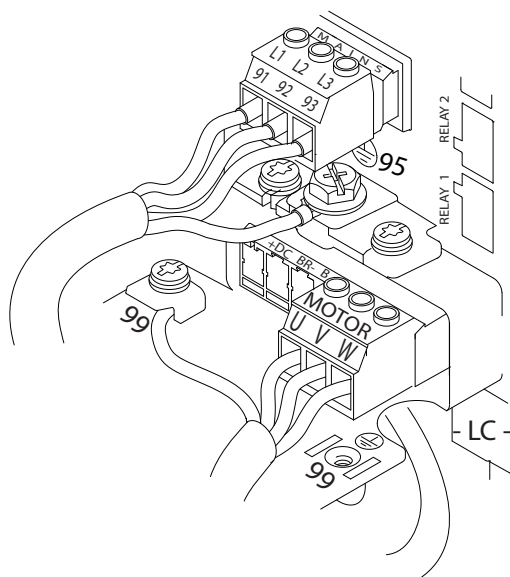

Figure 4.6 Example of Motor, Line Power and Ground Wiring

130BD531.10

4.7 AC Line Input Connection

- Size wiring based upon the input current of the adjustable frequency drive. For maximum wire sizes, see *chapter 8.1 Electrical Data*.
- Comply with local and national electrical codes for cable sizes.

Procedure

1. Connect 3-phase AC input power wiring to terminals L1, L2, and L3 (see *Figure 4.6*).
2. Depending on the configuration of the equipment, input power is connected to the line power input terminals or the input disconnect.
3. Ground the cable in accordance with grounding instructions provided in *chapter 4.3 Grounding*.
4. When supplied from an isolated line power source (IT line power or floating delta) or TT/TN-S line power with a grounded leg (grounded delta), ensure that *14-50 RFI 1* is set to OFF to avoid damage to the intermediate circuit and to reduce ground capacity currents in accordance with IEC 61800-3.

4.8 Control Wiring

- Isolate control wiring from high power components in the adjustable frequency drive.
- When the adjustable frequency drive is connected to a thermistor, ensure that the thermistor control wiring is shielded and reinforced/double insulated. A 24 V DC supply voltage is recommended.

130BB920.10

4.8.1 Control Terminal Types

Figure 4.7 and Figure 4.8 show the removable adjustable frequency drive connectors. Terminal functions and default settings are summarized in Table 4.3 and Table 4.4.

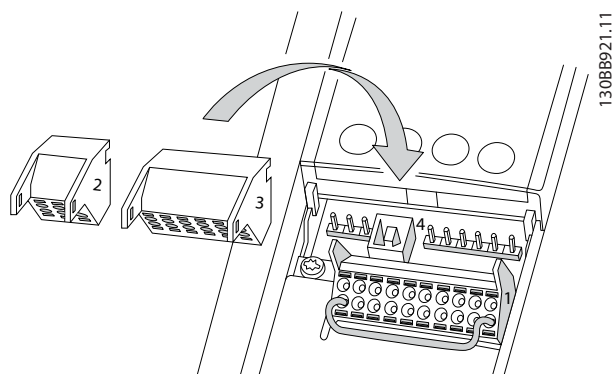

Figure 4.7 Control Terminal Locations

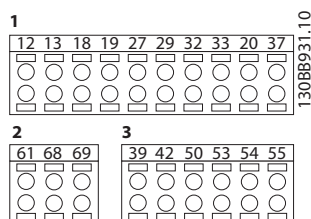

Figure 4.8 Terminal Numbers

- Connector 1** provides four programmable digital inputs terminals, two additional digital terminals programmable as either input or output, a 24 V DC terminal supply voltage, and a common for optional customer supplied 24 V DC voltage. FC 302 and FC 301 (optional in A1 enclosure) also provide a digital input for STO (Safe Torque Off) function
- Connector 2** terminals (+)68 and (-)69 for RS-485 serial communication connection
- Connector 3** provides two analog inputs, one analog output, 10 V DC supply voltage, and commons for the inputs and output
- Connector 4** is a USB port available for use with the MCT 10 Set-up Software

Terminal description			
Terminal	Parameter	Default setting	Description
Digital inputs/outputs			
12, 13	-	+24 V DC	24 V DC supply voltage for digital inputs and external transducers. Maximum output current 200 mA (130 mA for FC 301) for all 24 V loads.
18	5-10	[8] Start	Digital inputs.
19	5-11	[10] Reversing	
32	5-14	[0] No operation	
33	5-15	[0] No operation	
27	5-12	[2] Coast inverse	For digital input or output. Default setting is input.
29	5-13	[14] JOG	
20	-		Common for digital inputs and 0 V potential for 24 V supply.
37	-	Safe Torque Off (STO)	Safe input. Used for STO.
Analog inputs/outputs			
39	-		Common for analog output.
42	6-50	[0] No operation	Programmable analog output. 0-20 mA or 4-20 mA at a maximum of 500 Ω
50	-	+10 V DC	10 V DC analog supply voltage for potentiometer or thermistor. 15 mA maximum
53	6-1*	Reference	Analog input. For voltage or current. Switches A53 and A54 select mA or V.
54	6-2*	Feedback	
55	-		Common for analog input.

Table 4.3 Terminal Description Digital Inputs/Outputs, Analog Inputs/Outputs

Terminal description			
Terminal	Parameter	Default setting	Description
Serial communication			
61	-		Integrated RC filter for cable shield. ONLY for connecting the shield in the event of EMC problems.
68 (+)	8-3*		RS-485 Interface. A control card switch is provided for termination resistance.
69 (-)	8-3*		
Relays			
01, 02, 03	5-40 [0]	[0] No operation	Form C relay output. For AC or DC voltage and resistive or inductive loads.
04, 05, 06	5-40 [1]	[0] No operation	

Table 4.4 Terminal Description Serial Communication

Additional terminals:

- two form C relay outputs. Location of the outputs depends on adjustable frequency drive configuration.
- Terminals located on built-in optional equipment. See the manual provided with the equipment option.

4.8.2 Wiring to Control Terminals

Control terminal connectors can be unplugged from the adjustable frequency drive for ease of installation, as shown in *Figure 4.7*.

NOTICE!

Keep control wires as short as possible and separate from high power cables to minimize interference.

1. Open the contact by inserting a small screwdriver into the slot above the contact and push the screwdriver slightly upwards.

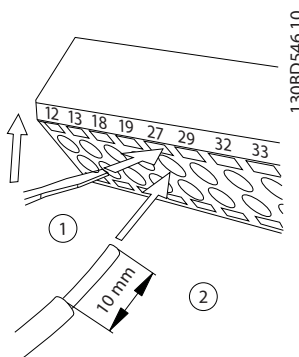

Figure 4.9 Connecting Control Wires

2. Insert the bared control wire into the contact.
3. Remove the screwdriver to fasten the control wire into the contact.
4. Ensure the contact is firmly established and not loose. Loose control wiring can be the source of equipment faults or less than optimal operation.

See *chapter 8.5 Cable Specifications* for control terminal wiring sizes and *chapter 6 Application Set-up Examples* for typical control wiring connections.

4.8.3 Enabling Motor Operation (Terminal 27)

A jumper wire may be required between terminal 12 (or 13) and terminal 27 for the adjustable frequency drive to operate when using factory default programming values.

- Digital input terminal 27 is designed to receive an 24 V DC external interlock command. In many applications, the user wires an external interlock device to terminal 27.
- When no interlock device is used, wire a jumper between control terminal 12 (recommended) or 13 to terminal 27. This provides an internal 24 V signal on terminal 27.
- When the status line at the bottom of the LCP reads AUTO REMOTE COAST, this indicates that the unit is ready to operate but is missing an input signal on terminal 27.
- When factory installed optional equipment is wired to terminal 27, do not remove that wiring.

NOTICE!

The adjustable frequency drive cannot operate without a signal on terminal 27 unless terminal 27 is re-programmed.

4.8.4 Voltage/Current Input Selection (Switches)

The analog input terminals 53 and 54 allow setting of input signal to voltage (0–10 V) or current (0/4–20 mA).

Default parameter settings:

- Terminal 53: speed reference signal in open-loop (see 16-61 Terminal 53 Switch Setting).
- Terminal 54: feedback signal in closed-loop (see 16-63 Terminal 54 Switch Setting).

NOTICE!

Disconnect power to the adjustable frequency drive before changing switch positions.

1. Remove the local control panel (see Figure 4.10).
2. Remove any optional equipment covering the switches.
3. Set switches A53 and A54 to select the signal type. U selects voltage, I selects current.

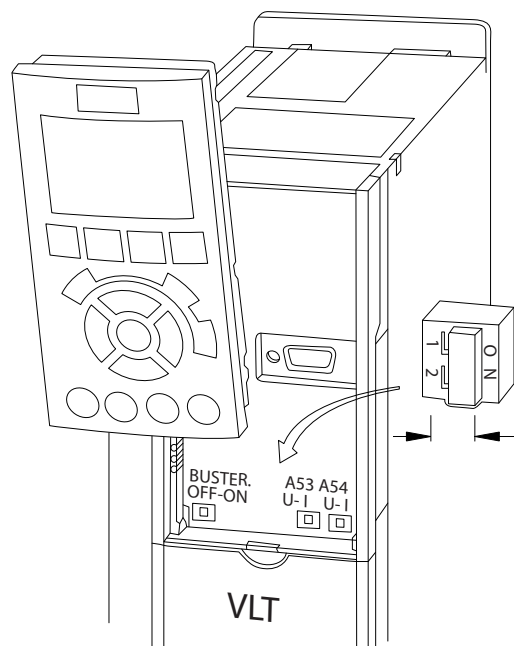

Figure 4.10 Location of Terminals 53 and 54 Switches

4.8.5 Safe Torque Off (STO)

To run Safe Torque Off, additional wiring for the adjustable frequency drive is required, refer to *Safe Torque Off Instruction Manual for Danfoss VLT® Adjustable Frequency Drives* for further information.

4.8.6 Mechanical Brake Control

In hoisting/lowering applications, it is necessary to control an electro-mechanical brake:

- Control the brake using any relay output or digital output (terminal 27 or 29).
- Keep the output closed (voltage-free) as long as the adjustable frequency drive is unable to keep the motor at standstill, for example due to the load being too heavy.

In hoisting/lowering applications, it is necessary to control an electro-mechanical brake:

- Select [32] *Mechanical brake control* in parameter group 5-4* *Relays* for applications with an electro-mechanical brake.
- The brake is released when the motor current exceeds the preset value in 2-20 *Release Brake Current*.
- The brake is engaged when the output frequency is less than the frequency set in 2-21 *Activate Brake Speed [RPM]* or 2-22 *Activate Brake Speed [Hz]*, and only if the adjustable frequency drive carries out a stop command.

If the adjustable frequency drive is in alarm mode or in an overvoltage situation, the mechanical brake immediately closes.

The adjustable frequency drive is not a safety device. It is the responsibility of the system designer to integrate safety devices according to relevant national crane/lift regulations.

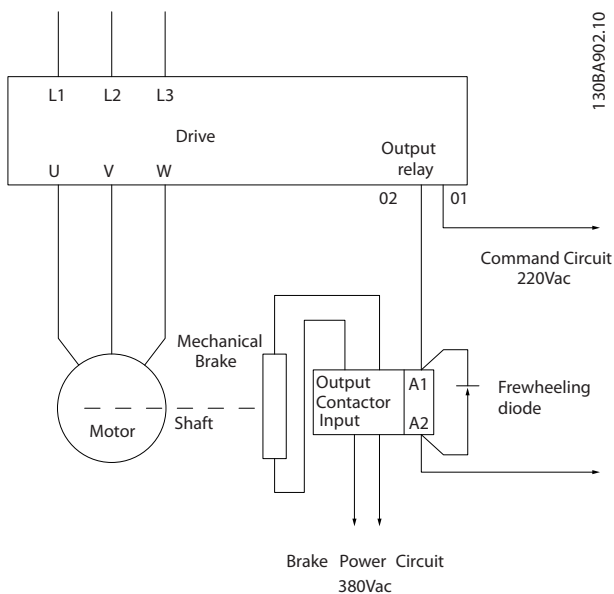

Figure 4.11 Connecting the Mechanical Brake to the Adjustable Frequency Drive

4.8.7 RS-485 Serial Communication

Connect RS-485 serial communication wiring to terminals (+)68 and (-)69.

- Use shielded serial communication cable (recommended)
- See chapter 4.3 *Grounding* for proper grounding

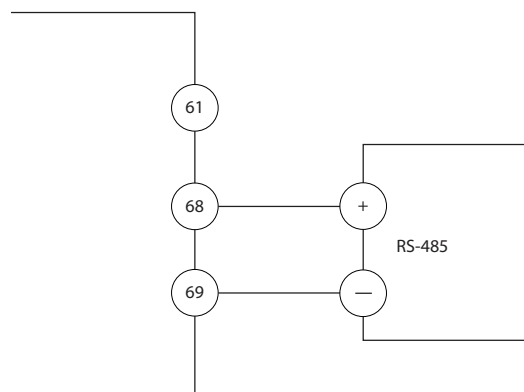

Figure 4.12 Serial Communication Wiring Diagram

For basic serial communication set-up, select the following:

1. Protocol type in 8-30 *Protocol*.
 2. Adjustable frequency drive address in 8-31 *Address*.
 3. Baud rate in 8-32 *Baud Rate*.
- Two communication protocols are internal to the adjustable frequency drive.
 - Danfoss FC
 - Modbus RTU
 - Functions can be programmed remotely using the protocol software and RS-485 connection or in parameter group 8-** *Communications and Options*.
 - Selecting a specific communication protocol changes various default parameter settings to match that protocol's specifications along with making additional protocol-specific parameters available.
 - Option cards which can be installed in the adjustable frequency drive are available to provide additional communication protocols. See the option-card documentation for installation and instruction manual.

4.9 Installation Check List

Before completing installation of the unit, inspect the entire installation as detailed in *Table 4.5*. Check and mark the items when completed.

Inspect for	Description	<input checked="" type="checkbox"/>
Auxiliary equipment	<ul style="list-style-type: none"> Look for auxiliary equipment, switches, disconnects, or input fuses/circuit breakers that may reside on the input power side of the adjustable frequency drive or output side to the motor. Ensure that they are ready for full-speed operation Check function and installation of any sensors used for feedback to the adjustable frequency drive. Remove any power factor correction caps on motor(s) Adjust any power factor correction caps on the line power side and ensure that they are dampened 	
Cable routing	<ul style="list-style-type: none"> Ensure that motor wiring and control wiring are separated or shielded or in three separate metallic conduits for high-frequency interference isolation 	
Control wiring	<ul style="list-style-type: none"> Check for broken or damaged wires and loose connections. Check that control wiring is isolated from power and motor wiring for noise immunity. Check the voltage source of the signals, if necessary. The use of shielded cable or twisted pair is recommended. Ensure that the shield is terminated correctly. 	
Cooling clearance	<ul style="list-style-type: none"> Measure that top and bottom clearance is adequate to ensure proper air flow for cooling, see <i>chapter 3.3 Mounting</i> 	
Ambient conditions	<ul style="list-style-type: none"> Check that requirements for ambient conditions are met 	
Fusing and circuit breakers	<ul style="list-style-type: none"> Check for proper fusing or circuit breakers. Check that all fuses are inserted firmly and are in operational condition and that all circuit breakers are in the open position 	
Grounding	<ul style="list-style-type: none"> Check for good ground connections that are tight and free of oxidation. Grounding to conduit or mounting the back panel to a metal surface is not a suitable grounding 	
Input and output power wiring	<ul style="list-style-type: none"> Check for loose connections. Check that motor and line power are in separate conduits or separated shielded cables. 	
Panel interior	<ul style="list-style-type: none"> Make sure that the unit interior is free of dirt, metal chips, moisture, and corrosion. Check that the unit is mounted on an unpainted, metal surface. 	
Switches	<ul style="list-style-type: none"> Ensure that all switch and disconnect settings are in the proper positions. 	
Vibration	<ul style="list-style-type: none"> Check that the unit is mounted solidly or that shock mounts are used, as necessary. Check for an unusual amount of vibration. 	

Table 4.5 Installation Check List

CAUTION

POTENTIAL HAZARD IN THE EVENT OF INTERNAL FAILURE!

Risk of personal injury when the adjustable frequency drive is not properly closed. Before applying power, ensure all safety covers are in place and securely fastened.

5 Commissioning

5.1 Safety Instructions

See *chapter 2 Safety* for general safety instructions.

⚠ WARNING

HIGH VOLTAGE!

Adjustable frequency drives contain high voltage when connected to AC line input power. Installation, start-up, and maintenance must be performed by qualified personnel only. Failure to perform installation, start-up, and maintenance by qualified personnel could result in death or serious injury.

Before applying power:

1. Close cover properly.
2. Check that all cable connectors are firmly tightened.
3. Ensure that input power to the unit is OFF and locked out. Do not rely on the adjustable frequency drive disconnect switches for input power isolation.
4. Verify that there is no voltage on input terminals L1 (91), L2 (92), and L3 (93), phase-to-phase and phase-to-ground.
5. Verify that there is no voltage on output terminals 96 (U), 97 (V), and 98 (W), phase-to-phase and phase-to-ground.
6. Confirm continuity of the motor by measuring ohm values on U-V (96-97), V-W (97-98), and W-U (98-96).
7. Check for proper grounding of the adjustable frequency drive as well as the motor.
8. Inspect the adjustable frequency drive for loose connections on terminals.
9. Confirm that the supply voltage matches voltage of adjustable frequency drive and motor.

5.2 Applying Power

⚠ WARNING

UNINTENDED START!

When the adjustable frequency drive is connected to AC line power, the motor may start at any time. The adjustable frequency drive, motor, and any driven equipment must be in operational readiness. Failure to be in operational readiness when the adjustable frequency drive is connected to AC line power could result in death, serious injury, equipment, or property damage.

1. Confirm that the input voltage is balanced within 3%. If not, correct input voltage imbalance before proceeding. Repeat this procedure after the voltage correction.
2. Ensure that optional equipment wiring (if present) matches the installation application.
3. Ensure that all operator devices are in the OFF position. Panel doors must be closed or cover mounted.
4. Apply power to the unit. DO NOT start the adjustable frequency drive at this time. For units with a disconnect switch, turn to the ON position to apply power to the adjustable frequency drive.

NOTICE!

If the status line at the bottom of the LCP reads **AUTO REMOTE COASTING** or *Alarm 60 External Interlock* is displayed, this indicates that the unit is ready to operate but is missing an input signal on terminal 27. See *chapter 4.8.3 Enabling Motor Operation (Terminal 27)* for details.

5.3 Local Control Panel Operation

5.3.1 Local Control Panel

The local control panel (LCP) is the combined display and keypad on the front of the unit.

The LCP has several user functions:

- Start, stop, and control speed when in local control
- Display operational data, status, warnings and cautions
- Programming adjustable frequency drive functions
- Manually reset the adjustable frequency drive after a fault when auto-reset is inactive

An optional numeric LCP (NLCP) is also available. The NLCP operates in a manner similar to the LCP. See the *Programming Guide* for details on use of the NLCP.

NOTICE!

For commissioning via PC, install MCT 10 Set-up Software. The software is available for download at www.danfoss.com/BusinessAreas/DrivesSolutions/Software-download (basic version) or for ordering (advanced version, order number 130B1000).

5.3.2 LCP Layout

The LCP is divided into four functional groups (see *Figure 5.1*).

- A. Display area
- B. Display menu keys
- C. Navigation keys and indicator lights (LEDs)
- D. Operation keys and reset

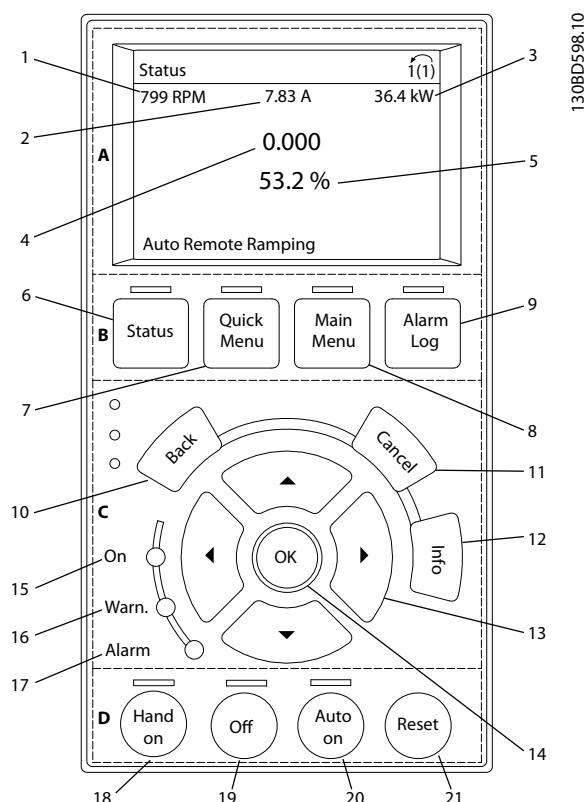

Figure 5.1 Local Control Panel (LCP)

A. Display area

The display area is activated when the adjustable frequency drive receives power from AC line voltage, a DC bus terminal, or an external 24 V DC supply.

The information displayed on the LCP can be customized for user application. Select options in the Quick Menu *Q3-13 Display Settings*.

Display	Parameter number	Default setting
1	0-20	Speed [RPM]
2	0-21	Motor Current
3	0-22	Power [kW]
4	0-23	Frequency
5	0-24	Reference [%]

Table 5.1 Legend to *Figure 5.1*, Display Area

B. Display menu keys

Menu keys are used for menu access for parameter set-up, toggling through status display modes during normal operation, and viewing fault log data.

	Key	Function
6	Status	Shows operational information.
7	Quick Menu	Allows access to programming parameters for initial set-up instructions and many detailed application instructions.
8	Main Menu	Allows access to all programming parameters.
9	Alarm Log	Displays a list of current warnings, the last ten alarms, and the maintenance log.

Table 5.2 Legend to Figure 5.1, Display Menu Keys

C. Navigation keys and LEDs

Navigation keys are used for programming functions and moving the display cursor. The navigation keys also provide speed control in local operation. There are also three adjustable frequency drive status indicator lights in this area.

	Key	Function
10	Back	Reverts to the previous step or list in the menu structure.
11	Cancel	Cancels the last change or command as long as the display mode has not changed.
12	Info	Press for a definition of the function being displayed.
13	Navigation Keys	Use the four navigation keys to move between items in the menu.
14	OK	Use to access parameter groups or to enable a choice.

Table 5.3 Legend to Figure 5.1, Navigation Keys

	Indicator	Light	Function
15	On	Green	The ON light activates when the adjustable frequency drive receives power from AC line voltage, a DC bus terminal, or an external 24 V supply.
16	Warn.	Yellow	When warning conditions are met, the yellow WARN light comes on and text appears in the display area identifying the problem.
17	Alarm	Red	A fault condition causes the red alarm light to flash and an alarm text is displayed.

Table 5.4 Legend to Figure 5.1, Indicator Lights (LEDs)

D. Operation keys and reset

Operation keys are located at the bottom of the LCP.

	Key	Function
18	Hand On	Starts the adjustable frequency drive in local control. <ul style="list-style-type: none"> An external stop signal by control input or serial communication overrides the local hand on
19	Off	Stops the motor but does not remove power to the adjustable frequency drive.
20	Auto On	Puts the system in remote operational mode. <ul style="list-style-type: none"> Responds to an external start command by control terminals or serial communication
21	Reset	Resets the adjustable frequency drive manually after a fault has been cleared.

Table 5.5 Legend to Figure 5.1, Operation Keys and Reset

NOTICE!

The display contrast can be adjusted by pressing [Status] and [▲]/[▼] keys.

5.3.3 Parameter Settings

Establishing the correct programming for applications often requires setting functions in several related parameters. Details for parameters are provided in *chapter 9.2 Parameter Menu Structure*.

Programming data are stored internally in the adjustable frequency drive.

- For backup, upload data into the LCP memory
- To download data to another adjustable frequency drive, connect the LCP to that unit and download the stored settings
- Restoring factory default settings does not change data stored in the LCP memory

5.3.4 Uploading/Downloading Data to/from the LCP

1. Press [Off] to stop the motor before uploading or downloading data.
2. Go to [Main Menu] *0-50 LCP Copy* and Press [OK].
3. Select *All to LCP* to upload data to LCP or select *All from LCP* to download data from the LCP.
4. Press [OK]. A progress bar shows the uploading or downloading process.
5. Press [Hand On] or [Auto On] to return to normal operation.

5.3.5 Changing Parameter Settings

View changes

Quick Menu Q5 - Changes Made lists all parameters changed from default settings.

- The list shows only parameters which have been changed in the current edit set-up.
- Parameters which have been reset to default values are not listed.
- The message 'Empty' indicates that no parameters have been changed.

Changing settings

Parameter settings can be accessed and changed from the [Quick Menu] or from the [Main Menu]. The [Quick Menu] only gives access to a limited number of parameters.

1. Press [Quick Menu] or [Main Menu] on the LCP.
2. Press [▲] [▼] to browse through the parameter groups, press [OK] to select a parameter group.
3. Press [▲] [▼] to browse through the parameters, press [OK] to select a parameter.
4. Press [▲] [▼] to change the value of a parameter setting.
5. Press [◀] [▶] to shift digit when a decimal parameter is in the editing state.
6. Press [OK] to accept the change.
7. Press either [Back] twice to enter "Status", or press [Main Menu] once to enter "Main Menu".

5.3.6 Restoring Default Settings

NOTICE!

Risk of losing programming, motor data, localization, and monitoring records by restoration of default settings. To provide a backup, upload data to the LCP before initialization.

Restoring the default parameter settings is done by initialization of the adjustable frequency drive. Initialization is carried out through *14-22 Operation Mode* (recommended) or manually.

- Initialization using *14-22 Operation Mode* does not reset adjustable frequency drive settings such as operating hours, serial communication selections, personal menu settings, fault log, alarm log, and other monitoring functions.
- Manual initialization erases all motor, programming, localization, and monitoring data and restores factory default settings.

Recommended initialization procedure, via 14-22 Operation Mode

1. Press [Main Menu] twice to access parameters.
2. Scroll to *14-22 Operation Mode* and press [OK].
3. Scroll to *Initialization* and press [OK].
4. Remove power to the unit and wait for the display to turn off.
5. Apply power to the unit.

Default parameter settings are restored during start-up. This may take slightly longer than normal.

6. Alarm 80 is displayed.
7. Press [Reset] to return to operation mode.

Manual initialization procedure

1. Remove power to the unit and wait for the display to turn off.
2. Press and hold [Status], [Main Menu], and [OK] at the same time while applying power to the unit (approximately 5 s or until audible click and fan starts).

Factory default parameter settings are restored during start-up. This may take slightly longer than normal.

Manual initialization does not reset the following adjustable frequency drive information:

- 15-00 Operating hours
- 15-03 Power-ups
- 15-04 Over Temps
- 15-05 Over Volts

5.4 Basic Programming

5.4.1 Commissioning with SmartStart

The SmartStart wizard enables fast configuration of basic motor and application parameters.

- At first power-up or after initialization of the adjustable frequency drive, SmartStart starts by itself.
- Follow on-screen instructions to complete commissioning of the adjustable frequency drive. SmartStart can always be reactivated by selecting *Quick Menu Q4 - SmartStart*.
- For commissioning without use of the SmartStart wizard, refer to *chapter 5.4.2 Commissioning via [Main Menu]* or the *Programming Guide*.

NOTICE!

Motor data are required for the SmartStart set-up. The required data are normally available on the motor nameplate.

5.4.2 Commissioning via [Main Menu]

Recommended parameter settings are intended for start-up and checkout purposes. Application settings may vary.

Enter data with power ON, but before operating the adjustable frequency drive.

1. Press [Main Menu] on the LCP.
2. Use the navigation keys to scroll to parameter group *0-** Operation/Display* and press [OK].

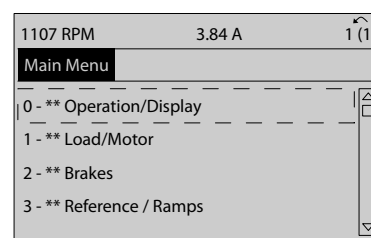

Figure 5.2 Main Menu

- Use navigation keys to scroll to parameter group *0-0* Basic Settings* and press [OK].

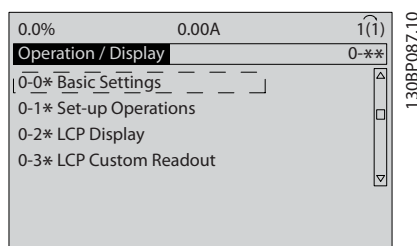

Figure 5.3 Operation/Display

- Use navigation keys to scroll to *0-03 Regional Settings* and press [OK].

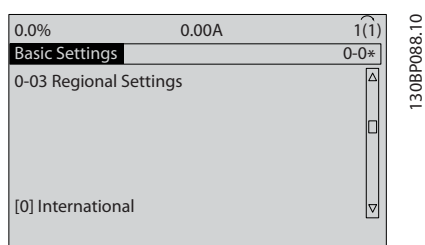

Figure 5.4 Basic Settings

- Use navigation keys to select *[0] International* or *[1] North America* as appropriate and press [OK]. (This changes the default settings for a number of basic parameters).
- Press [Main Menu] on the LCP.
- Use the navigation keys to scroll to *0-01 Language*.
- Select language and press [OK].
- If a jumper wire is in place between control terminals 12 and 27, leave *5-12 Terminal 27 Digital Input* at factory default. Otherwise, select *No Operation* in *5-12 Terminal 27 Digital Input*. For adjustable frequency drives with an optional bypass, no jumper wire is required between control terminals 12 and 27.
- 3-02 Minimum Reference*
- 3-03 Maximum Reference*
- 3-41 Ramp 1 Ramp-up Time*
- 3-42 Ramp 1 Ramp-down Time*
- 3-13 Reference Site*. Linked to Hand/Auto Local Remote.

5.4.3 Asynchronous Motor Set-up

Enter the motor data in parameters 1-20 or 1-21 to 1-25. The information can be found on the motor nameplate.

- 1-20 Motor Power [kW] or 1-21 Motor Power [HP]*
- 1-22 Motor Voltage*
- 1-23 Motor Frequency*
- 1-24 Motor Current*
- 1-25 Motor Nominal Speed*

5.4.4 PM Motor Set-up in VVC^{plus}

Initial Programming Steps

- Activate PM motor operation *1-10 Motor Construction*, select *[1] PM, non salient SPM*
- Set *0-02 Motor Speed Unit* to *[0] RPM*

Programming motor data

After selecting PM motor in *1-10 Motor Construction*, the PM motor-related parameters in parameter groups *1-2**, *1-3** and *1-4** are active.

The necessary data can be found on the motor nameplate and in the motor data sheet.

Program the following parameters in the listed order

- 1-24 Motor Current*
- 1-26 Motor Cont. Rated Torque*
- 1-25 Motor Nominal Speed*
- 1-39 Motor Poles*
- 1-30 Stator Resistance (Rs)*
Enter line to common stator winding resistance (Rs). If only line-line data are available, divide the line-line value by 2 to achieve the line to common (starpoint) value.
- 1-37 d-axis Inductance (Ld)*
Enter line to common direct axis inductance of the PM motor.
If only line-line data are available, divide the line-line value by 2 to achieve the line-common (starpoint) value.

7. *1-40 Back EMF at 1000 RPM*

Enter line-to-line back EMF of PM Motor at 1000 RPM mechanical speed (RMS value). Back EMF is the voltage generated by a PM motor when no drive is connected and the shaft is turned externally. Back EMF is normally specified for nominal motor speed or for 1,000 RPM measured between two lines. If the value is not available for a motor speed of 1000 RPM, calculate the correct value as follows: If back EMF is, e.g., 320 V at 1800 RPM, it can be calculated at 1000 RPM as follows: Back EMF = (Voltage / RPM)*1000 = (320/1800)*1000 = 178. This is the value that must be programmed for *1-40 Back EMF at 1000 RPM*.

Test Motor Operation

1. Start the motor at low speed (100 to 200 RPM). If the motor does not turn, check installation, general programming and motor data.
2. Check if start function in *1-70 PM Start Mode* fits the application requirements.

Rotor detection

This function is the recommended choice for applications where the motor starts from standstill, e.g., pumps or conveyors. On some motors, an acoustic sound is heard when the impulse is sent out. This does not harm the motor.

Parking

This function is the recommended choice for applications where the motor is rotating at slow speed, e.g., windmilling in fan applications. *2-06 Parking Current* and *2-07 Parking Time* can be adjusted. Increase the factory setting of these parameters for applications with high inertia.

Start the motor at nominal speed. If the application does not run well, check the VVC^{plus} PM settings. Recommendations for different applications can be seen in *Table 5.6*.

Application	Settings
Low inertia applications $I_{Load}/I_{Motor} < 5$	<i>1-17 Voltage filter time const.</i> to be increased by factor 5 to 10 <i>1-14 Damping Gain</i> should be reduced <i>1-66 Min. Current at Low Speed</i> should be reduced (<100%)
Low inertia applications $50 > I_{Load}/I_{Motor} > 5$	Keep calculated values
High inertia applications $I_{Load}/I_{Motor} > 50$	<i>1-14 Damping Gain</i> , <i>1-15 Low Speed Filter Time Const.</i> and <i>1-16 High Speed Filter Time Const.</i> should be increased
High load at low speed <30% (rated speed)	<i>1-17 Voltage filter time const.</i> should be increased <i>1-66 Min. Current at Low Speed</i> should be increased (>100% for a prolonged time can overheat the motor)

Table 5.6 Recommendations for Different Applications

If the motor starts oscillating at a certain speed, increase *1-14 Damping Gain*. Increase the value in small steps. Depending on the motor, a good value for this parameter can be 10% or 100% higher than the default value.

Starting torque can be adjusted in *1-66 Min. Current at Low Speed*. 100% provides nominal torque as starting torque.

5.4.5 Automatic Motor Adaptation (AMA)

NOTICE!

AMA is not relevant for permanent magnet motors.

Automatic motor adaptation (AMA) is a procedure that optimizes compatibility between the adjustable frequency drive and the motor.

- The adjustable frequency drive builds a mathematical model of the motor for regulating output motor current. The procedure also tests the input phase balance of electrical power. It compares the motor characteristics with the data entered in parameters 1-20 to 1-25
- The motor shaft does not turn and no harm is done to the motor while running the AMA.
- Some motors may be unable to run the complete version of the test. In that case, select [2] Enable reduced AMA.
- If an output filter is connected to the motor, select Enable reduced AMA.
- If warnings or alarms occur, see *chapter 7.4 List of Warnings and Alarms*
- Run this procedure on a cold motor for best results.

To run AMA

1. Press [Main Menu] to access parameters.
2. Scroll to parameter group 1-** *Load and Motor* and press [OK].
3. Scroll to parameter group 1-2* *Motor Data* and press [OK].
4. Scroll to 1-29 *Automatic Motor Adaptation (AMA)* and press [OK].
5. Select [1] *Enable complete AMA* and press [OK].
6. Follow the on-screen instructions.
7. The test runs automatically and indicate when it is complete.

5.5 Checking Motor Rotation

Before running the adjustable frequency drive, check the motor rotation.

1. Press [Hand On].
2. Press [►] for positive speed reference.
3. Check that the speed displayed is positive.

When 1-06 *Clockwise Direction* is set to [0] *Normal* (default clockwise):

- 4a. Verify that the motor turns clockwise.
- 5a. Verify that the LCP direction arrow is clockwise.

When 1-06 *Clockwise Direction* is set to [1] *Inverse* (counter-clockwise):

- 4b. Verify that the motor turns counter-clockwise.
- 5b. Verify that the LCP direction arrow is counter-clockwise.

5.6 Checking Encoder Rotation

NOTICE!

When using an encoder option, refer to the option manual.

Check encoder rotation only if encoder feedback is used. Check encoder rotation in default open-loop control.

1. Verify that the encoder connection is according to *Figure 5.5*:

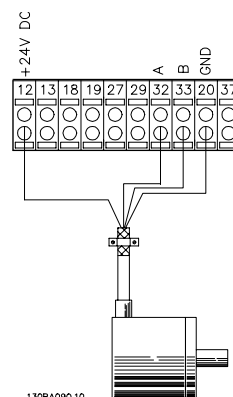

Figure 5.5 Wiring Diagram

2. Enter the speed PID feedback source in *7-00 Speed PID Feedback Source*.
3. Press [Hand On].
4. Press [►] for positive speed reference (*1-06 Clockwise Direction* at [0] Normal).
5. Check in *16-57 Feedback [RPM]* that the feedback is positive.

NOTICE

If the feedback is negative, the encoder connection is wrong!

5.7 Local Control Test

WARNING**MOTOR START!**

Ensure that the motor, system, and any attached equipment are ready for start. It is the responsibility of the user to ensure safe operation under any condition. Failure to ensure that the motor, system, and any attached equipment are ready for start could result in personal injury or equipment damage.

1. Press [Hand On] to provide a local start command to the adjustable frequency drive.
2. Accelerate the adjustable frequency drive by pressing [▲] to full speed. Moving the cursor left of the decimal point provides quicker input changes.
3. Note any acceleration problems.
4. Press [Off]. Note any deceleration problems.

In the event of acceleration or deceleration problems, see *chapter 7.5 Troubleshooting*. See *chapter 7.4 List of Warnings and Alarms* for resetting the adjustable frequency drive after a trip.

5.8 System Start-up

The procedure in this section requires user-wiring and application programming to be completed. The following procedure is recommended after application set-up is completed.

WARNING**MOTOR START!**

Ensure that the motor, system, and any attached equipment are ready for start. It is the responsibility of the user to ensure safe operation under any condition. Failure to ensure that the motor, system, and any attached equipment are ready for start could result in personal injury or equipment damage.

1. Press [Auto On].
2. Apply an external run command.
3. Adjust the speed reference throughout the speed range.
4. Remove the external run command.
5. Check sound and vibration level of the motor to ensure that the system is working as intended.

If warnings or alarms occur, see *chapter 7.4 List of Warnings and Alarms*.

6 Application Set-up Examples

The examples in this section are intended as a quick reference for common applications.

- Parameter settings are the regional default values unless otherwise indicated (selected in *0-03 Regional Settings*).
- Parameters associated with the terminals and their settings are shown next to the drawings.
- Where switch settings for analog terminals A53 or A54 are required, these are also shown.

NOTICE!

When the optional Safe Torque Off feature is used, a jumper wire may be required between terminal 12 (or 13) and terminal 37 for the adjustable frequency drive to operate when using factory default programming values.

6.1 Application Examples

6.1.1 AMA

		Parameters	
FC		Function	Setting
+24 V	12	1-29 Automatic	
+24 V	13	Motor	[1] Enable
D IN	18	Adaptation	complete
D IN	19	(AMA)	AMA
COM	20	5-12 Terminal 27	[2]* Coast
D IN	27	Digital Input	inverse
D IN	29	* = Default Value	
D IN	32	Notes/comments:	
D IN	33	Parameter group 1-2* must be set according to motor	
D IN	37	D IN 37 is an option.	
+10 V	50		
A IN	53		
A IN	54		
COM	55		
A OUT	42		
COM	39		

Table 6.1 AMA with T27 Connected

		Parameters	
FC		Function	Setting
+24 V	12	1-29 Automatic	
+24 V	13	Motor	[1] Enable
D IN	18	Adaptation	complete
D IN	19	(AMA)	AMA
COM	20	5-12 Terminal 27	[0] No
D IN	27	Digital Input	operation
D IN	29	* = Default Value	
D IN	32	Notes/comments:	
D IN	33	Parameter group 1-2* must be set according to motor	
D IN	37	D IN 37 is an option.	
+10 V	50		
A IN	53		
A IN	54		
COM	55		
A OUT	42		
COM	39		

Table 6.2 AMA without T27 Connected

6.1.2 Speed

6

		Parameters	
FC		Function	Setting
+24 V	120	6-10 Terminal 53	0.07 V*
+24 V	130	Low Voltage	
D IN	180	6-11 Terminal 53	10 V*
D IN	190	High Voltage	
COM	200	6-14 Terminal 53	0 RPM
D IN	270	Low Ref./Feedb. Value	
D IN	290	6-15 Terminal 53	1500 RPM
D IN	320	High Ref./Feedb. Value	
D IN	330		
D IN	370		
+10 V		* = Default Value	
A IN	530	Notes/comments: D IN 37 is an option.	
A IN	540		
COM	550		
A OUT	420		
COM	390		
U - I			
A53			

Table 6.3 Analog Speed Reference (Voltage)

		Parameters	
FC		Function	Setting
+24 V	120	6-12 Terminal 53	4 mA*
+24 V	130	Low Current	
D IN	180	6-13 Terminal 53	20 mA*
D IN	190	High Current	
COM	200	6-14 Terminal 53	0 RPM
D IN	270	Low Ref./Feedb. Value	
D IN	290	6-15 Terminal 53	1500 RPM
D IN	320	High Ref./Feedb. Value	
D IN	330		
D IN	370		
+10 V		* = Default Value	
A IN	530	Notes/comments: D IN 37 is an option.	
A IN	540		
COM	550		
A OUT	420		
COM	390		
U - I			
A53			

Table 6.4 Analog Speed Reference (Current)

		Parameters	
FC		Function	Setting
+24 V	120	6-10 Terminal 53	0.07 V*
+24 V	130	Low Voltage	
D IN	180	6-11 Terminal 53	10 V*
D IN	190	High Voltage	
COM	200	6-14 Terminal 53	0 RPM
D IN	270	Low Ref./Feedb. Value	
D IN	290	6-15 Terminal 53	1500 RPM
D IN	320	High Ref./Feedb. Value	
D IN	330		
D IN	370		
+10 V		* = Default Value	
A IN	530	Notes/comments: D IN 37 is an option.	
A IN	540		
COM	550		
A OUT	420		
COM	390		
U - I			
A53			

Table 6.5 Speed Reference (using a Manual Potentiometer)

		Parameters	
FC		Function	Setting
+24 V	120	5-10 Terminal 18	[8] Start*
+24 V	130	Digital Input	
D IN	180	5-12 Terminal 27	[19] Freeze Reference
D IN	190	Digital Input	
COM	200	5-13 Terminal 29	[21] Speed Up
D IN	270	Digital Input	
D IN	290	5-14 Terminal 32	[22] Slow
D IN	320	Digital Input	
D IN	330		
D IN	370		
+10 V		* = Default Value	
A IN	530	Notes/comments: D IN 37 is an option.	
A IN	540		
COM	550		
A OUT	420		
COM	390		
U - I			
A53			

Table 6.6 Speed Up/Slow

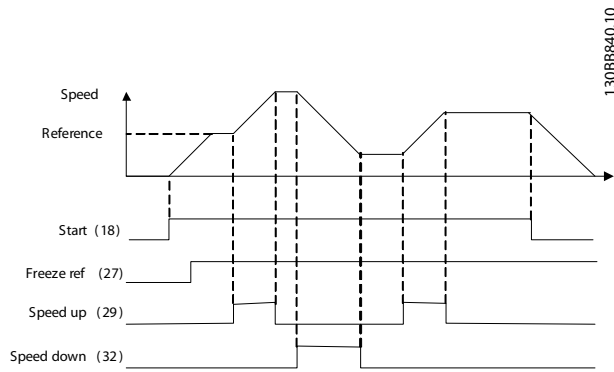

Figure 6.1 Speed Up/Slow

6.1.3 Start/Stop

		Parameters	
FC		Function	Setting
+24 V	12	5-10 Terminal 18	[8] Start*
+24 V	13	Digital Input	
D IN	18	5-12 Terminal 27	[0] No operation
D IN	19	Digital Input	
COM	20	5-19 Terminal 37	[1] Safe Stop Alarm
D IN	27		
D IN	29		
D IN	32		
D IN	33		
D IN	37		
* = Default Value			
Notes/comments:			
If 5-12 Terminal 27 Digital Input is set to [0] No operation, a jumper wire to terminal 27 is not needed.			
D IN 37 is an option.			

Table 6.7 Start/Stop Command with Safe Stop Option

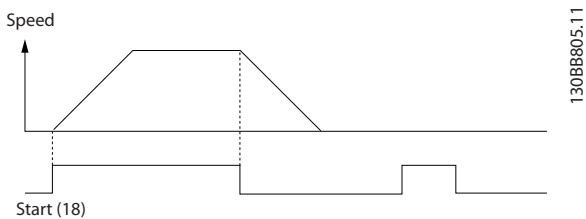

Figure 6.2 Start/Stop Command with Safe Stop

		Parameters	
FC		Function	Setting
+24 V	12	5-10 Terminal 18	[9] Latched
+24 V	13	Digital Input	Start
D IN	18	5-12 Terminal 27	[6] Stop
D IN	19	Digital Input	Inverse
COM	20		
* = Default Value			
Notes/comments:			
If 5-12 Terminal 27 Digital Input is set to [0] No operation, a jumper wire to terminal 27 is not needed.			
D IN 37 is an option.			

Table 6.8 Pulse Start/Stop

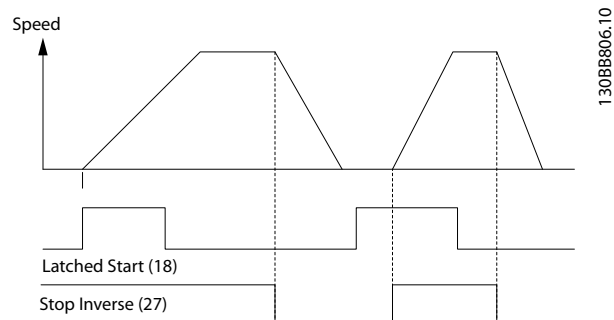

Figure 6.3 Latched Start/Stop Inverse

		Parameters	
FC		Function	Setting
+24 V	12	5-10 Terminal 18 Digital Input	[8] Start
+24 V	13		
D IN	18	5-11 Terminal 19 Digital Input	[10] Reversing*
D IN	19		
COM	20		
D IN	27		
D IN	29	5-12 Terminal 27 Digital Input	[0] No operation
D IN	32		
D IN	33	5-14 Terminal 32 Digital Input	[16] Preset ref bit 0
D IN	37	5-15 Terminal 33 Digital Input	[17] Preset ref bit 1
+10 V	50		
A IN	53		
A IN	54		
COM	55		
A OUT	42		
COM	39		
		3-10 Preset Reference	
		Preset ref. 0	25%
		Preset ref. 1	50%
		Preset ref. 2	75%
		Preset ref. 3	100%
		* = Default Value	
		Notes/comments: D IN 37 is an option.	

Table 6.9 Start/Stop with Reversing and Four Preset Speeds

6.1.4 External Alarm Reset

		Parameters	
FC		Function	Setting
+24 V	12	5-11 Terminal 19 Digital Input	[1] Reset
+24 V	13		
D IN	18		
D IN	19		
COM	20		
D IN	27		
D IN	29		
D IN	32		
D IN	33		
D IN	37		
+10 V	50		
A IN	53		
A IN	54		
COM	55		
A OUT	42		
COM	39		
		* = Default Value	
		Notes/comments: D IN 37 is an option.	

Table 6.10 External Alarm Reset

6.1.5 RS-485

		Parameters	
FC		Function	Setting
+24 V	12	8-30 Protocol	FC*
+24 V	13	8-31 Address	1*
D IN	18	8-32 Baud Rate	9600*
D IN	19	* = Default Value	
COM	20	Notes/comments:	
D IN	27	Select protocol, address and baud rate in the above-mentioned parameters.	
D IN	29	D IN 37 is an option.	
D IN	32		
D IN	33		
D IN	37		
+10 V	50		
A IN	53		
A IN	54		
COM	55		
A OUT	42		
COM	39		
R1	01		
	02		
	03		
R2	04		
	05		
	06		
	61		
	68		
	69		

Table 6.11 RS-485 Network Connection

6.1.6 Motor Thermistor

CAUTION

Use only thermistors with reinforced or double insulation to meet PELV insulation requirements.

		Parameters	
VLT		Function	Setting
+24 V	12	1-90 Motor Thermal Protection	[2] Thermistor trip
+24 V	13		
D IN	18	1-93 Thermistor Source	[1] Analog input 53
D IN	19	* = Default Value	
COM	20	Notes/comments:	
D IN	27	If only a warning is desired, 1-90 Motor Thermal Protection should be set to [1] Thermistor warning.	
D IN	29	D IN 37 is an option.	
D IN	32		
D IN	33		
D IN	37		
+10 V	50		
A IN	53		
A IN	54		
COM	55		
A OUT	42		
COM	39		
U-1			
A53			

Table 6.12 Motor Thermistor

6.1.7 SLC

		Parameters																																																																																	
		Function	Setting																																																																																
<table border="1"> <tr><th colspan="2">FC</th></tr> <tr><td>+24 V</td><td>12</td></tr> <tr><td>+24 V</td><td>13</td></tr> <tr><td>D IN</td><td>18</td></tr> <tr><td>D IN</td><td>19</td></tr> <tr><td>COM</td><td>20</td></tr> <tr><td>D IN</td><td>27</td></tr> <tr><td>D IN</td><td>29</td></tr> <tr><td>D IN</td><td>32</td></tr> <tr><td>D IN</td><td>33</td></tr> <tr><td>D IN</td><td>37</td></tr> <tr><td colspan="2"> </td></tr> <tr><td>+10 V</td><td>50</td></tr> <tr><td>A IN</td><td>53</td></tr> <tr><td>A IN</td><td>54</td></tr> <tr><td>COM</td><td>55</td></tr> <tr><td>A OUT</td><td>42</td></tr> <tr><td>COM</td><td>39</td></tr> <tr><td colspan="2"> </td></tr> <tr><td>R1</td><td>01</td></tr> <tr><td></td><td>02</td></tr> <tr><td></td><td>03</td></tr> <tr><td colspan="2"> </td></tr> <tr><td>R2</td><td>04</td></tr> <tr><td></td><td>05</td></tr> <tr><td></td><td>06</td></tr> </table>		FC		+24 V	12	+24 V	13	D IN	18	D IN	19	COM	20	D IN	27	D IN	29	D IN	32	D IN	33	D IN	37			+10 V	50	A IN	53	A IN	54	COM	55	A OUT	42	COM	39			R1	01		02		03			R2	04		05		06	130BB839.10	<table border="1"> <tr><td>4-30 Motor Feedback Loss Function</td><td>[1] Warning</td></tr> <tr><td>4-31 Motor Feedback Speed Error</td><td>100 RPM</td></tr> <tr><td>4-32 Motor Feedback Loss Timeout</td><td>5 s</td></tr> <tr><td>7-00 Speed PID Feedback Source</td><td>[2] MCB 102</td></tr> <tr><td>17-11 Resolution (PPR)</td><td>1024*</td></tr> <tr><td>13-00 SL Controller Mode</td><td>[1] On</td></tr> <tr><td>13-01 Start Event</td><td>[19] Warning</td></tr> <tr><td>13-02 Stop Event</td><td>[44] Reset key</td></tr> <tr><td>13-10 Comparator Operand</td><td>[21] Warning no.</td></tr> <tr><td>13-11 Comparator Operator</td><td>[1] ≈*</td></tr> <tr><td>13-12 Comparator Value</td><td>90</td></tr> <tr><td>13-51 SL Controller Event</td><td>[22] Comparator 0</td></tr> <tr><td>13-52 SL Controller Action</td><td>[32] Set digital out A low</td></tr> <tr><td>5-40 Function Relay</td><td>[80] SL digital output A</td></tr> </table>	4-30 Motor Feedback Loss Function	[1] Warning	4-31 Motor Feedback Speed Error	100 RPM	4-32 Motor Feedback Loss Timeout	5 s	7-00 Speed PID Feedback Source	[2] MCB 102	17-11 Resolution (PPR)	1024*	13-00 SL Controller Mode	[1] On	13-01 Start Event	[19] Warning	13-02 Stop Event	[44] Reset key	13-10 Comparator Operand	[21] Warning no.	13-11 Comparator Operator	[1] ≈*	13-12 Comparator Value	90	13-51 SL Controller Event	[22] Comparator 0	13-52 SL Controller Action	[32] Set digital out A low	5-40 Function Relay	[80] SL digital output A
FC																																																																																			
+24 V	12																																																																																		
+24 V	13																																																																																		
D IN	18																																																																																		
D IN	19																																																																																		
COM	20																																																																																		
D IN	27																																																																																		
D IN	29																																																																																		
D IN	32																																																																																		
D IN	33																																																																																		
D IN	37																																																																																		
+10 V	50																																																																																		
A IN	53																																																																																		
A IN	54																																																																																		
COM	55																																																																																		
A OUT	42																																																																																		
COM	39																																																																																		
R1	01																																																																																		
	02																																																																																		
	03																																																																																		
R2	04																																																																																		
	05																																																																																		
	06																																																																																		
4-30 Motor Feedback Loss Function	[1] Warning																																																																																		
4-31 Motor Feedback Speed Error	100 RPM																																																																																		
4-32 Motor Feedback Loss Timeout	5 s																																																																																		
7-00 Speed PID Feedback Source	[2] MCB 102																																																																																		
17-11 Resolution (PPR)	1024*																																																																																		
13-00 SL Controller Mode	[1] On																																																																																		
13-01 Start Event	[19] Warning																																																																																		
13-02 Stop Event	[44] Reset key																																																																																		
13-10 Comparator Operand	[21] Warning no.																																																																																		
13-11 Comparator Operator	[1] ≈*																																																																																		
13-12 Comparator Value	90																																																																																		
13-51 SL Controller Event	[22] Comparator 0																																																																																		
13-52 SL Controller Action	[32] Set digital out A low																																																																																		
5-40 Function Relay	[80] SL digital output A																																																																																		
		*=-Default Value																																																																																	
		Notes/comments: If the limit in the feedback monitor is exceeded, Warning 90 will be issued. The SLC monitors Warning 90 and if Warning 90 becomes TRUE, then Relay 1 is triggered. External equipment may then indicate that service may be required. If the feedback error goes below the limit again within 5 sec then the adjustable frequency drive continues and the warning disappears. But Relay 1 will still be triggered until [Reset] on the LCP.																																																																																	

Table 6.13 Using SLC to Set a Relay

6.1.8 Mechanical Brake Control

		Parameters																																																																					
		Function	Setting																																																																				
<table border="1"> <tr><th colspan="2">FC</th></tr> <tr><td>+24 V</td><td>12</td></tr> <tr><td>+24 V</td><td>13</td></tr> <tr><td>D IN</td><td>18</td></tr> <tr><td>D IN</td><td>19</td></tr> <tr><td>COM</td><td>20</td></tr> <tr><td>D IN</td><td>27</td></tr> <tr><td>D IN</td><td>29</td></tr> <tr><td>D IN</td><td>32</td></tr> <tr><td>D IN</td><td>33</td></tr> <tr><td>D IN</td><td>37</td></tr> <tr><td colspan="2"> </td></tr> <tr><td>+10 V</td><td>50</td></tr> <tr><td>A IN</td><td>53</td></tr> <tr><td>A IN</td><td>54</td></tr> <tr><td>COM</td><td>55</td></tr> <tr><td>A OUT</td><td>42</td></tr> <tr><td>COM</td><td>39</td></tr> <tr><td colspan="2"> </td></tr> <tr><td>R1</td><td>01</td></tr> <tr><td></td><td>02</td></tr> <tr><td></td><td>03</td></tr> <tr><td colspan="2"> </td></tr> <tr><td>R2</td><td>04</td></tr> <tr><td></td><td>05</td></tr> <tr><td></td><td>06</td></tr> </table>		FC		+24 V	12	+24 V	13	D IN	18	D IN	19	COM	20	D IN	27	D IN	29	D IN	32	D IN	33	D IN	37			+10 V	50	A IN	53	A IN	54	COM	55	A OUT	42	COM	39			R1	01		02		03			R2	04		05		06	130BB841.10	<table border="1"> <tr><td>5-40 Function Relay</td><td>[32] Mech. brake ctrl.</td></tr> <tr><td>5-10 Terminal 18 Digital Input</td><td>[8] Start*</td></tr> <tr><td>5-11 Terminal 19 Digital Input</td><td>[11] Start reversing</td></tr> <tr><td>1-71 Start Delay</td><td>0.2</td></tr> <tr><td>1-72 Start Function</td><td>[5] VVC^{plus}/FLUX Clockwise</td></tr> <tr><td>1-76 Start Current</td><td>I_{m,n}</td></tr> <tr><td>2-20 Release Brake Current</td><td>App. dependent</td></tr> <tr><td>2-21 Activate Brake Speed [RPM]</td><td>Half of nominal slip of the motor</td></tr> </table>	5-40 Function Relay	[32] Mech. brake ctrl.	5-10 Terminal 18 Digital Input	[8] Start*	5-11 Terminal 19 Digital Input	[11] Start reversing	1-71 Start Delay	0.2	1-72 Start Function	[5] VVC ^{plus} /FLUX Clockwise	1-76 Start Current	I _{m,n}	2-20 Release Brake Current	App. dependent	2-21 Activate Brake Speed [RPM]	Half of nominal slip of the motor
FC																																																																							
+24 V	12																																																																						
+24 V	13																																																																						
D IN	18																																																																						
D IN	19																																																																						
COM	20																																																																						
D IN	27																																																																						
D IN	29																																																																						
D IN	32																																																																						
D IN	33																																																																						
D IN	37																																																																						
+10 V	50																																																																						
A IN	53																																																																						
A IN	54																																																																						
COM	55																																																																						
A OUT	42																																																																						
COM	39																																																																						
R1	01																																																																						
	02																																																																						
	03																																																																						
R2	04																																																																						
	05																																																																						
	06																																																																						
5-40 Function Relay	[32] Mech. brake ctrl.																																																																						
5-10 Terminal 18 Digital Input	[8] Start*																																																																						
5-11 Terminal 19 Digital Input	[11] Start reversing																																																																						
1-71 Start Delay	0.2																																																																						
1-72 Start Function	[5] VVC ^{plus} /FLUX Clockwise																																																																						
1-76 Start Current	I _{m,n}																																																																						
2-20 Release Brake Current	App. dependent																																																																						
2-21 Activate Brake Speed [RPM]	Half of nominal slip of the motor																																																																						
		*=-Default Value																																																																					
		Notes/comments:																																																																					

Table 6.14 Mechanical Brake Control

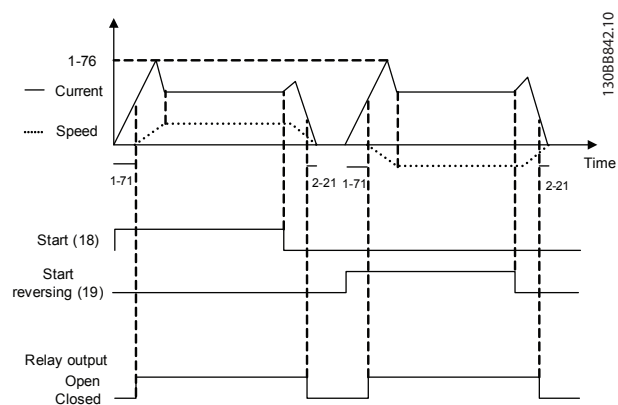

Figure 6.4 Mechanical Brake Control

7 Diagnostics and Troubleshooting

This chapter includes maintenance and service guidelines, status messages, warnings and alarms and basic troubleshooting.

7.1 Maintenance and Service

Under normal operating conditions and load profiles, the adjustable frequency drive is maintenance-free throughout its designed lifetime. To prevent breakdown, danger, and damage, examine the adjustable frequency drive at regular intervals depending on the operating conditions. Replace worn or damaged parts with original spare parts or standard parts. For service and support, refer to www.danfoss.com/contact/sales_and_services/.

CAUTION

Danfoss AUTHORIZED PERSONNEL!

Risk of personal injury or equipment damage. Repair and service must be carried out by Danfoss authorized personnel only.

7.2 Status Messages

When the adjustable frequency drive is in status mode, status messages are generated automatically and appear in the bottom line of the display (see *Figure 7.1*).

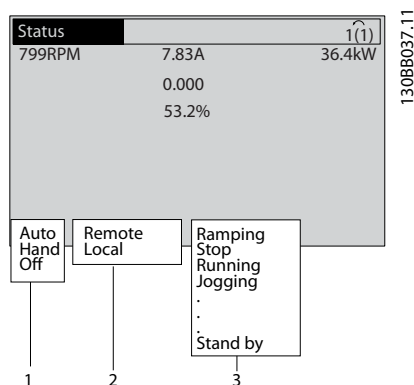

Figure 7.1 Status Display

1	Operation Mode (see <i>Table 7.2</i>)
2	Reference Site (see <i>Table 7.3</i>)
3	Operation Status (see <i>Table 7.4</i>)

Table 7.1 Legend to *Figure 7.1*

Table 7.2 to *Table 7.4* describe the displayed status messages.

Off	The adjustable frequency drive does not react to any control signal until [Auto On] or [Hand On] is pressed.
Auto On	The adjustable frequency drive is controlled from the control terminals and/or the serial communication.
	The adjustable frequency drive is controlled by the navigation keys on the LCP. Stop commands, reset, reversing, DC brake, and other signals applied to the control terminals will override local control.

Table 7.2 Operation Mode

Remote	The speed reference is given from external signals, serial communication, or internal preset references.
Local	The adjustable frequency drive uses [Hand On] control or reference values from the LCP.

Table 7.3 Reference Site

AC Brake	AC Brake was selected in <i>2-10 Brake Function</i> . The AC brake overmagnetizes the motor to achieve a controlled slow-down.
AMA finish OK	Automatic motor adaptation (AMA) was carried out successfully.
AMA ready	AMA is ready to start. Press [Hand On] to start.
AMA running	AMA process is in progress.
Braking	The brake chopper is in operation. Generative energy is absorbed by the brake resistor.
Braking max.	The brake chopper is in operation. The power limit for the brake resistor defined in <i>2-12 Brake Power Limit (kW)</i> has been reached.
Coast	<ul style="list-style-type: none"> Coast inverse was selected as a function for a digital input (parameter group <i>5-1* Digital Inputs</i>). The corresponding terminal is not connected. Coast activated by serial communication

Ctrl. Ramp-down	<p>Control Ramp-down was selected in <i>14-10 Mains Failure</i>.</p> <ul style="list-style-type: none"> The AC line voltage is below the value set in <i>14-11 Mains Voltage at Mains Fault</i> at line power fault The adjustable frequency drive ramps down the motor using a controlled ramp-down.
Current High	The adjustable frequency drive output current is above the limit set in <i>4-51 Warning Current High</i> .
Current Low	The adjustable frequency drive output current is below the limit set in <i>4-52 Warning Speed Low</i> .
DC Hold	DC Hold is selected in <i>1-80 Function at Stop</i> and a stop command is active. The motor is held by a DC current set in <i>2-00 DC Hold/Preheat Current</i> .
DC Stop	<p>The motor is held with a DC current (<i>2-01 DC Brake Current</i>) for a specified time (<i>2-02 DC Braking Time</i>).</p> <ul style="list-style-type: none"> DC Brake is activated in <i>2-03 DC Brake Cut-in Speed [RPM]</i> and a stop command is active. DC Brake (inverse) is selected as a function for a digital input (parameter group <i>5-1* Digital Inputs</i>). The corresponding terminal is not active. The DC Brake is activated via serial communication.
Feedback high	The sum of all active feedbacks is above the feedback limit set in <i>4-57 Warning Feedback High</i> .
Feedback low	The sum of all active feedbacks is below the feedback limit set in <i>4-56 Warning Feedback Low</i> .
Freeze output	<p>The remote reference is active, which holds the present speed.</p> <ul style="list-style-type: none"> Freeze output was selected as a function for a digital input (parameter group <i>5-1* Digital Inputs</i>). The corresponding terminal is active. Speed control is only possible via the terminal functions Speed Up and Slow. Hold ramp is activated via serial communication.
Freeze output request	A freeze output command was given, but the motor remains stopped until a run permissive signal is received.

Freeze ref.	<i>Freeze Reference</i> was chosen as a function for a digital input (parameter group <i>5-1* Digital Inputs</i>). The corresponding terminal is active. The adjustable frequency drive saves the actual reference. Changing the reference is now only possible via terminal functions Speed Up and Slow.
Jog request	A jog command was given but the motor remains stopped until a run permissive signal is received via a digital input.
Jogging	<p>The motor is running as programmed in <i>3-19 Jog Speed [RPM]</i>.</p> <ul style="list-style-type: none"> <i>Jog</i> was selected as function for a digital input (parameter group <i>5-1* Digital Inputs</i>). The corresponding terminal (e.g., Terminal 29) is active. The Jog function is activated via the serial communication. The Jog function was selected as a reaction for a monitoring function (e.g., No signal). The monitoring function is active.
Motor check	In <i>1-80 Function at Stop, Motor Check</i> was selected. A stop command is active. To ensure that a motor is connected to the adjustable frequency drive, a permanent test current is applied to the motor.
Over Voltage Control (OVC)	<i>Overvoltage</i> control was activated in <i>2-17 Overvoltage Control, [2] Enabled</i> . The connected motor is supplying the adjustable frequency drive with generative energy. The overvoltage control adjusts the V/Hz ratio to run the motor in controlled mode and to prevent the adjustable frequency drive from tripping.
PowerUnit Off	(Only adjustable frequency drives with an external 24 V power supply installed). Line power supply to the adjustable frequency drive was removed, and the control card is supplied by the external 24 V.
Protection md	<p>Protection mode is active. The unit has detected a critical status (overcurrent or overvoltage).</p> <ul style="list-style-type: none"> To avoid tripping, switching frequency is reduced to 4 kHz. If possible, Protection mode ends after approximately 10 s. Protection mode can be restricted in <i>14-26 Trip Delay at Inverter Fault</i>.

QStop	The motor is decelerating using 3-81 <i>Quick Stop Ramp Time</i> . <ul style="list-style-type: none"> • <i>Quick stop inverse</i> was chosen as a function for a digital input (parameter group 5-1* <i>Digital Inputs</i>). The corresponding terminal is not active. • The quick stop function was activated via serial communication.
Ramping	The motor is accelerating/decelerating using the active Ramp-Up/Down. The reference, a limit value, or a standstill is not yet reached.
Ref. high	The sum of all active references is above the reference limit set in 4-55 <i>Warning Reference High</i> .
Ref. low	The sum of all active references is below the reference limit set in 4-54 <i>Warning Reference Low</i> .
Run on ref.	The adjustable frequency drive is running in the reference range. The feedback value matches the setpoint value.
Run request	A start command was given, but the motor remains stopped until a run permissive signal is received via digital input.
Running	The motor is driven by the adjustable frequency drive.
Sleep Mode	The energy-saving function is enabled. The motor has stopped but restarts automatically when required.
Speed high	Motor speed is above the value set in 4-53 <i>Warning Speed High</i> .
Speed low	Motor speed is below the value set in 4-52 <i>Warning Speed Low</i> .
Standby	In Auto On mode, the adjustable frequency drive starts the motor with a start signal from a digital input or serial communication.
Start delay	In 1-71 <i>Start Delay</i> , a delay starting time was set. A start command is activated and the motor starts after the start delay time expires.
Start fwd/rev	Start forward and start reverse were selected as functions for two different digital inputs (parameter group 5-1* <i>Digital Inputs</i>). The motor starts in forward or reverse depending on which corresponding terminal is activated.
Stop	The adjustable frequency drive has received a stop command from the LCP, digital input, or serial communication.
Trip	An alarm occurred and the motor is stopped. Once the cause of the alarm is cleared, the adjustable frequency drive can be reset manually by pressing [Reset] or remotely by control terminals or serial communication.

Trip lock	An alarm occurred and the motor is stopped. Once the cause of the alarm is cleared, power must be cycled to the adjustable frequency drive. The adjustable frequency drive can then be reset manually by pressing [Reset] or remotely by control terminals or serial communication.
-----------	---

Table 7.4 Operation Status

NOTICE!

In auto/remote mode, the adjustable frequency drive requires external commands to execute functions.

7.3 Warning and Alarm Types

Warnings

A warning is issued when an alarm condition is impending or when an abnormal operating condition is present and may result in the adjustable frequency drive issuing an alarm. A warning clears by itself when the abnormal condition is removed.

Alarms

Trip

An alarm is issued when the adjustable frequency drive is tripped, which means that the adjustable frequency drive suspends operation to prevent adjustable frequency drive or system damage. The motor coasts to a stop. The adjustable frequency drive logic continues to operate and monitor the adjustable frequency drive status. After the fault condition is remedied, the adjustable frequency drive can be reset. It is then ready to start operation again.

Resetting the adjustable frequency drive after trip/trip lock

A trip can be reset in any of four ways:

- Press [Reset] on the LCP
- Digital reset input command
- Serial communication reset input command
- Auto reset

Trip lock

Input power is cycled. The motor coasts to a stop. The adjustable frequency drive continues to monitor the adjustable frequency drive status. Remove input power to the adjustable frequency drive, correct the cause of the fault, and reset the adjustable frequency drive.

Warning and Alarm Displays

- A warning is displayed in the LCP along with the warning number.
- An alarm flashes along with the alarm number.

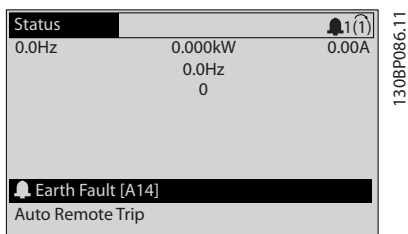

Figure 7.2 Alarm Display Example

7

In addition to the text and alarm code on the LCP of the adjustable frequency drive, there are three status indicator lights.

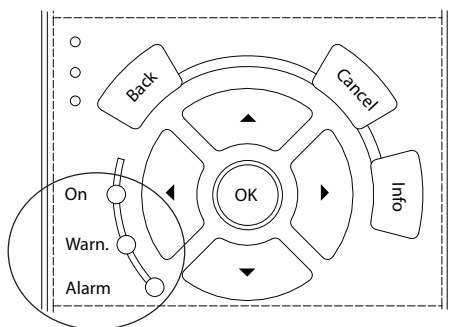

Figure 7.3 Status Indicator Lights

	Warning LED	Alarm LED
Warning	On	Off
Alarm	Off	On (Flashing)
Trip Lock	On	On (Flashing)

Table 7.5 Status Indicator Lights Explanations

7.4 List of Warnings and Alarms

The warning/alarm information below defines each warning/alarm condition, provides the probable cause for the condition, and details a remedy or troubleshooting procedure.

WARNING 1, 10 Volts low

The control card voltage is below 10 V from terminal 50. Remove some of the load from terminal 50, as the 10 V supply is overloaded. Max. 15 mA or minimum 590 Ω.

A short circuit in a connected potentiometer or improper wiring of the potentiometer can cause this condition.

Troubleshooting

Remove the wiring from terminal 50. If the warning clears, the problem is with the wiring. If the warning does not clear, replace the control card.

WARNING/ALARM 2, Live zero error

This warning or alarm only appears if programmed in 6-01 Live Zero Timeout Function. The signal on one of the analog inputs is less than 50% of the minimum value programmed for that input. Broken wiring or faulty device sending the signal can cause this condition.

Troubleshooting

Check connections on all the analog input terminals. Control card terminals 53 and 54 for signals, terminal 55 common. MCB 101 terminals 11 and 12 for signals, terminal 10 common. MCB 109 terminals 1, 3, 5 for signals, terminals 2, 4, 6 common).

Check that the frequency converter programming and switch settings match the analog signal type.

Perform Input Terminal Signal Test.

WARNING/ALARM 3, No motor

No motor has been connected to the output of the frequency converter.

WARNING/ALARM 4, Mains phase loss

A phase is missing on the supply side, or the line voltage imbalance is too high. This message also appears for a fault in the input rectifier on the adjustable frequency drive. Options are programmed at 14-12 Function at Mains Imbalance.

Troubleshooting

Check the supply voltage and supply currents to the adjustable frequency drive.

WARNING 5, DC link voltage high

The intermediate circuit voltage (DC) is higher than the high-voltage warning limit. The limit is dependent on the frequency converter voltage rating. The unit is still active.

WARNING 6, DC link voltage low

The intermediate circuit voltage (DC) is lower than the low-voltage warning limit. The limit is dependent on the frequency converter voltage rating. The unit is still active.

WARNING/ALARM 7, DC overvoltage

If the intermediate circuit voltage exceeds the limit, the adjustable frequency drive trips after a time.

Troubleshooting

- Connect a brake resistor
- Extend the ramp time
- Change the ramp type
- Activate the functions in *2-10 Brake Function*
- Increase *14-26 Trip Delay at Inverter Fault*
- If the alarm/warning occurs during a power sag, use kinetic backup (*14-10 Line Failure*)

WARNING/ALARM 8, DC under voltage

If the intermediate circuit voltage (DC link) drops below the under voltage limit, the frequency converter checks if a 24 V DC back-up supply is connected. If no 24 V DC back-up supply is connected, the frequency converter trips after a fixed time delay. The time delay varies with unit size.

Troubleshooting

- Check that the supply voltage matches the frequency converter voltage.
- Perform input voltage test.
- Perform soft charge circuit test.

WARNING/ALARM 9, Inverter overload

The frequency converter is about to cut out because of an overload (too high current for too long). The counter for electronic, thermal inverter protection issues a warning at 98% and trips at 100%, while giving an alarm. The frequency converter *cannot* be reset until the counter is below 90%.

The fault is that the frequency converter has run with more than 100% overload for too long.

Troubleshooting

- Compare the output current shown on the LCP with the frequency converter rated current.
- Compare the output current shown on the LCP with measured motor current.

Display the Thermal Drive Load on the LCP and monitor the value. When running above the frequency converter continuous current rating, the counter increases. When running below the frequency converter continuous current rating, the counter decreases.

WARNING/ALARM 10, Motor overload temperature

According to the electronic thermal protection (ETR), the motor is too hot. Select whether the adjustable frequency drive issues a warning or an alarm when the counter reaches 100% in *1-90 Motor Thermal Protection*. The fault occurs when the motor runs with more than 100% overload for too long.

Troubleshooting

- Check for motor overheating.
- Check if the motor is mechanically overloaded
- Check that the motor current set in *1-24 Motor Current* is correct.
- Ensure that Motor data in parameters 1-20 to 1-25 are set correctly.
- If an external fan is in use, check in *1-91 Motor External Fan* that it is selected.
- Running AMA in *1-29 Automatic Motor Adaptation (AMA)* tunes the adjustable frequency drive to the motor more accurately and reduces thermal loading.

WARNING/ALARM 11, Motor thermistor over temp

Check whether the thermistor is disconnected. Select whether the adjustable frequency drive issues a warning or an alarm in *1-90 Motor Thermal Protection*.

Troubleshooting

- Check for motor overheating.
- Check if the motor is mechanically overloaded.
- When using terminal 53 or 54, check that the thermistor is connected correctly between either terminal 53 or 54 (analog voltage input) and terminal 50 (+10 V supply). Also check that the terminal switch for 53 or 54 is set for voltage. Check *1-93 Thermistor Source* selects terminal 53 or 54.
- When using digital inputs 18 or 19, check that the thermistor is connected correctly between either terminal 18 or 19 (digital input PNP only) and terminal 50. Check *1-93 Thermistor Source* selects terminal 18 or 19.

WARNING/ALARM 12, Torque limit

The torque has exceeded the value in *4-16 Torque Limit Motor Mode* or the value in *4-17 Torque Limit Generator Mode*. *14-25 Trip Delay at Torque Limit* can change this warning from a warning-only condition to a warning followed by an alarm.

Troubleshooting

If the motor torque limit is exceeded during ramp-up, extend the ramp-up time.

If the generator torque limit is exceeded during ramp-down, extend the ramp-down time.

If torque limit occurs while running, possibly increase the torque limit. Make sure that the system can operate safely at a higher torque.

Check the application for excessive current draw on the motor.

WARNING/ALARM 13, Over current

The inverter peak current limit (approximately 200% of the rated current) is exceeded. The warning lasts about 1.5 s, then the adjustable frequency drive trips and issues an alarm. Shock loading or quick acceleration with high inertia loads can cause this fault. It can also appear after kinetic backup if the acceleration during ramp-up is quick. If extended mechanical brake control is selected, trip can be reset externally.

Troubleshooting

Remove power and check if the motor shaft can be turned.

Make sure that the motor size matches the adjustable frequency drive.

Check parameters 1-20 to 1-25 for correct motor data.

ALARM 14, Earth (ground) fault

There is current from the output phases to ground, either in the cable between the adjustable frequency drive and the motor or in the motor itself.

Troubleshooting

Remove power to the adjustable frequency drive and repair the ground fault.

Check for ground faults in the motor by measuring the resistance to ground of the motor leads and the motor with a megohmmeter.

ALARM 15, Hardware mismatch

A fitted option is not operational with the present control board hardware or software.

Record the value of the following parameters and contact your Danfoss supplier:

15-40 FC Type

15-41 Power Section

15-42 Voltage

15-43 Software Version

15-45 Actual Typecode String

15-49 SW ID Control Card

15-50 SW ID Power Card

15-60 Option Mounted

15-61 Option SW Version (for each option slot)

ALARM 16, Short circuit

There is short-circuiting in the motor or motor wiring.

Remove power to the adjustable frequency drive and repair the short circuit.

WARNING/ALARM 17, Control word timeout

There is no communication to the adjustable frequency drive.

The warning is only active when *8-04 Control Word Timeout Function* is NOT set to [0] Off.

If *8-04 Control Word Timeout Function* is set to [5] Stop and Trip, a warning appears and the adjustable frequency drive ramps down until it stops then displays an alarm.

Troubleshooting

Check connections on the serial communication cable.

Increase *8-03 Control Word Timeout Time*

Check the operation of the communication equipment.

Verify a proper installation based on EMC requirements.

WARNING/ALARM 20, Temp. input error

The temperature sensor is not connected.

WARNING/ALARM 21, Parameter error

The parameter is out of range. The parameter number is reported in the LCP. The affected parameter must be set to a valid value.

WARNING/ALARM 22, Hoist mechanical brake

Report value shows what kind it is.

0 = The torque ref. was not reached before timeout (Parameter 2-27).

1 = Expected brake feedback not received before timeout (Parameters 2-23, 2-25).

WARNING 23, Internal fan fault

The fan warning function is an extra protective function that checks if the fan is running/mounted. The fan warning can be disabled in *14-53 Fan Monitor ([0] Disabled)*.

For the D, E, and F Frame filters, the regulated voltage to the fans is monitored.

Troubleshooting

Check for proper fan operation.

Cycle power to the adjustable frequency drive and check that the fan operates briefly at start-up.

Check the sensors on the heatsink and control card.

WARNING 24, External fan fault

The fan warning function is an extra protective function that checks if the fan is running/mounted. The fan warning can be disabled in *14-53 Fan Monitor ([0] Disabled)*.

Troubleshooting

Check for proper fan operation.

Cycle power to the adjustable frequency drive and check that the fan operates briefly at start-up.

Check the sensors on the heatsink and control card.

WARNING 25, Brake resistor short circuit

The brake resistor is monitored during operation. If a short circuit occurs, the brake function is disabled and the warning appears. The adjustable frequency drive is still operational but without the brake function. Remove power to the adjustable frequency drive and replace the brake resistor (see *2-15 Brake Check*).

WARNING/ALARM 26, Brake resistor power limit

The power transmitted to the brake resistor is calculated as a mean value over the last 120 seconds of run time. The calculation is based on the intermediate circuit voltage and the brake resistance value set in *2-16 AC Brake Max. Current*. The warning is active when the dissipated braking energy is higher than 90% of the brake resistance power. If *[2] Trip* is selected in *2-13 Brake Power Monitoring*, the adjustable frequency drive trips when the dissipated braking energy reaches 100%.

WARNING/ALARM 27, Brake chopper fault

The brake transistor is monitored during operation and if a short circuit occurs, the brake function is disabled and a warning is issued. The adjustable frequency drive is still operational but, since the brake transistor has short-circuited, substantial power is transmitted to the brake resistor, even if it is inactive.

Remove power to the adjustable frequency drive and remove the brake resistor.

WARNING/ALARM 28, Brake check failed

The brake resistor is not connected or not working. Check *2-15 Brake Check*.

ALARM 29, Heatsink temp

The maximum temperature of the heatsink has been exceeded. The temperature fault will not reset until the temperature falls below a defined heatsink temperature. The trip and reset points are different based on the adjustable frequency drive power size.

Troubleshooting

Check for the following conditions.

Ambient temperature too high.

Motor cable too long.

Incorrect airflow clearance above and below the adjustable frequency drive.

Blocked airflow around the adjustable frequency drive.

Damaged heatsink fan.

Dirty heatsink.

ALARM 30, Motor phase U missing

Motor phase U between the adjustable frequency drive and the motor is missing.

Remove power from the adjustable frequency drive and check motor phase U.

ALARM 31, Motor phase V missing

Motor phase V between the adjustable frequency drive and the motor is missing.

Remove power from the adjustable frequency drive and check motor phase V.

ALARM 32, Motor phase W missing

Motor phase W between the adjustable frequency drive and the motor is missing.

Remove power from the adjustable frequency drive and check motor phase W.

ALARM 33, Inrush fault

Too many power-ups have occurred within a short time period. Let the unit cool to operating temperature.

WARNING/ALARM 34, Fieldbus communication fault

The serial communication bus on the communication option card is not working.

WARNING/ALARM 35, Option fault

An option alarm is received. The alarm is option-specific. The most likely cause is a power-up or a communication fault.

WARNING/ALARM 36, Mains failure

This warning/alarm is only active if the supply voltage to the frequency converter is lost and *14-10 Mains Failure* is NOT set to [0] *No Function*. Check the fuses to the frequency converter and mains supply to the unit.

ALARM 37, Phase imbalance

There is a current imbalance between the power units

ALARM 38, Internal fault

When an internal fault occurs, a code number defined in *Table 7.6* is displayed.

Troubleshooting

Cycle power

Check that the option is properly installed

Check for loose or missing wiring

It may be necessary to contact your Danfoss supplier or service department. Note the code number for further troubleshooting directions.

No.	Text
0	Serial port cannot be initialized. Contact your Danfoss supplier or Danfoss Service Department.
256-258	Power EEPROM data is defective or too old
512	Control board EEPROM data is defective or too old.
513	Communication timeout reading EEPROM data
514	Communication timeout reading EEPROM data
515	Application-oriented control cannot recognize the EEPROM data.
516	Cannot write to the EEPROM because a write command is on progress.
517	Write command is under timeout
518	Failure in the EEPROM
519	Missing or invalid barcode data in EEPROM
783	Parameter value outside of min/max limits
1024-1279	A CAN message that has to be sent could not be sent.
1281	Digital signal processor flash timeout
1282	Power micro software version mismatch
1283	Power EEPROM data version mismatch
1284	Cannot read digital signal processor software version
1299	Option SW in slot A is too old
1300	Option SW in slot B is too old

No.	Text
1301	Option SW in slot C0 is too old
1302	Option SW in slot C1 is too old
1315	Option SW in slot A is not supported (not allowed)
1316	Option SW in slot B is not supported (not allowed)
1317	Option SW in slot C0 is not supported (not allowed)
1318	Option SW in slot C1 is not supported (not allowed)
1379	Option A did not respond when calculating platform version
1380	Option B did not respond when calculating platform version
1381	Option C0 did not respond when calculating platform version.
1382	Option C1 did not respond when calculating platform version.
1536	An exception in the application-oriented control is registered. Debug information written in LCP.
1792	HW reset of DSP
1793	Motor-derived parameters not transferred correctly to DSP
1794	Power data not transferred correctly at power-up to DSP
1795	The DSP has received too many unknown SPI messages
1796	RAM copy error
2049	Power data restarted
2064-2072	H081x: Option in slot x has restarted
2080-2088	H082x: Option in slot x has issued a power-up wait
2096-2104	H983x: Option in slot x has issued a legal power-up wait
2304	Could not read any data from power EEPROM
2305	Missing SW version from power unit
2314	Missing power unit data from power unit
2315	Missing SW version from power unit
2316	Missing lo_statepage from power unit
2324	Power card configuration is determined to be incorrect at power-up
2325	A power card has stopped communicating while line power is applied
2326	Power card configuration is determined to be incorrect after the delay for power cards to register.
2327	Too many power card locations have been registered as present.
2330	Power size information between the power cards does not match.
2561	No communication from DSP to ATACD
2562	No communication from ATACD to DSP (state running)
2816	Stack overflow control board module

No.	Text
2817	Scheduler slow tasks
2818	Fast tasks
2819	Parameter thread
2820	LCP stack overflow
2821	Serial port overflow
2822	USB port overflow
2836	cfListMempool too small
3072-5122	Parameter value is outside its limits
5123	Option in slot A: Hardware incompatible with control board hardware
5124	Option in slot B: Hardware incompatible with control board hardware.
5125	Option in slot C0: Hardware incompatible with control board hardware.
5126	Option in slot C1: Hardware incompatible with control board hardware.
5376-6231	Out of memory

Table 7.6 Internal Fault, Code Numbers

ALARM 39, Heatsink sensor

No feedback from the heatsink temperature sensor.

The signal from the IGBT thermal sensor is not available on the power card. The problem could be on the power card, on the gate drive card, or the ribbon cable between the power card and gate drive card.

WARNING 40, Overload of digital output terminal 27

Check the load connected to terminal 27 or remove short-circuit connection. Check *5-00 Digital I/O Mode* and *5-01 Terminal 27 Mode*.

WARNING 41, Overload of digital output terminal 29

Check the load connected to terminal 29 or remove short-circuit connection. Check *5-00 Digital I/O Mode* and *5-02 Terminal 29 Mode*.

WARNING 42, Overload of digital output on X30/6 or overload of digital output on X30/7

For X30/6, check the load connected to X30/6 or remove the short-circuit connection. Check *5-32 Term X30/6 Digi Out (MCB 101)*.

For X30/7, check the load connected to X30/7 or remove the short-circuit connection. Check *5-33 Term X30/7 Digi Out (MCB 101)*.

ALARM 43, Ext. supply

MCB 113 Ext. Relay Option is mounted without ext. 24V DC. Either connect an ext. 24V DC supply or specify that no external supply is used via *14-80 Option Supplied by External 24VDC* [0]. A change in *14-80 Option Supplied by External 24VDC* requires a power cycle.

ALARM 45, Earth fault 2

Ground fault.

Troubleshooting

Check for proper grounding and loose connections.

Check for proper wire size.

Check motor cables for short-circuits or leakage currents.

ALARM 46, Power card supply

The supply on the power card is out of range.

There are three power supplies generated by the switch mode power supply (SMPS) on the power card: 24 V, 5 V, ± 18 V. When powered with 24 V DC with the MCB 107 option, only the 24 V and 5 V supplies are monitored. When powered with three phase AC line voltage, all three supplies are monitored.

Troubleshooting

Check for a defective power card.

Check for a defective control card.

Check for a defective option card.

If a 24 V DC power supply is used, verify proper supply power.

WARNING 47, 24 V supply low

The 24 V DC is measured on the control card. The external 24 V DC backup power supply may be overloaded; otherwise, contact the Danfoss supplier.

WARNING 48, 1.8 V supply low

The 1.8 V DC supply used on the control card is outside of allowable limits. The power supply is measured on the control card. Check for a defective control card. If an option card is present, check for an overvoltage condition.

WARNING 49, Speed limit

When the speed is not within the specified range in *4-11 Motor Speed Low Limit [RPM]* and *4-13 Motor Speed High Limit [RPM]*, the adjustable frequency drive shows a warning. When the speed is below the specified limit in *1-86 Trip Speed Low [RPM]* (except when starting or stopping), the adjustable frequency drive trips.

ALARM 50, AMA calibration failed

Contact your Danfoss supplier or Danfoss Service Department.

ALARM 51, AMA check U_{nom} and I_{nom}

The settings for motor voltage, motor current and motor power are wrong. Check the settings in parameters 1-20 to 1-25.

ALARM 52, AMA low I_{nom}

The motor current is too low. Check the settings.

ALARM 53, AMA motor too big

The motor is too big for the AMA to operate.

ALARM 54, AMA motor too small

The motor is too small for the AMA to operate.

ALARM 55, AMA parameter out of range

The parameter values of the motor are outside of the acceptable range. AMA cannot run.

ALARM 56, AMA interrupted by user

The user has interrupted the AMA.

ALARM 57, AMA internal fault

Try to restart AMA again. Repeated restarts can overheat the motor.

ALARM 58, AMA Internal fault

Contact your Danfoss supplier.

WARNING 59, Current limit

The current is higher than the value in *4-18 Current Limit*. Ensure that Motor data in parameters 1-20 to 1-25 are set correctly. Possibly increase the current limit. Be sure that the system can operate safely at a higher limit.

WARNING 60, External interlock

A digital input signal is indicating a fault condition external to the frequency converter. An external interlock has commanded the frequency converter to trip. Clear the external fault condition. To resume normal operation, apply 24 V DC to the terminal programmed for external interlock. Reset the frequency converter.

WARNING/ALARM 61, Feedback error

An error between calculated speed and speed measurement from feedback device. The function Warning/Alarm/Disabling setting is in *4-30 Motor Feedback Loss Function*. Accepted error setting in *4-31 Motor Feedback Speed Error* and the allowed time the error occur setting in *4-32 Motor Feedback Loss Timeout*. During a commissioning procedure the function may be effective.

WARNING 62, Output frequency at maximum limit

The output frequency has reached the value set in *4-19 Max Output Frequency*. Check the application to determine the cause. Possibly increase the output frequency limit. Be sure the system can operate safely at a higher output frequency. The warning will clear when the output drops below the maximum limit.

ALARM 63, Mechanical brake low

The actual motor current has not exceeded the "release brake" current within the "Start delay" time window.

ALARM 64, Voltage Limit

The load and speed combination demands a motor voltage higher than the actual DC link voltage.

WARNING/ALARM 65, Control card over temperature

The cut-out temperature of the control card is 176 °F [80 °C].

Troubleshooting

- Check that the ambient operating temperature is within limits.
- Check for clogged filters.
- Check fan operation.
- Check the control card.

WARNING 66, Heatsink temperature low

The frequency converter is too cold to operate. This warning is based on the temperature sensor in the IGBT module.

Increase the ambient temperature of the unit. Also, a trickle amount of current can be supplied to the frequency converter whenever the motor is stopped by setting *2-00 DC Hold/Preheat Current* at 5% and *1-80 Function at Stop*

ALARM 67, Option module configuration has changed

One or more options have either been added or removed since the last power-down. Check that the configuration change is intentional and reset the unit.

ALARM 68, Safe Stop activated

Safe stop has been activated. To resume normal operation, apply 24 V DC to terminal 37, then send a reset signal (via Bus, Digital I/O, or by pressing the reset key).

ALARM 69, Power card temperature

The temperature sensor on the power card is either too hot or too cold.

Troubleshooting

- Check that the ambient operating temperature is within limits.
- Check for clogged filters.
- Check fan operation.
- Check the power card.

ALARM 70, Illegal FC configuration

The control card and power card are incompatible. To check compatibility, contact your supplier with the type code of the unit from the nameplate and the part numbers of the cards.

ALARM 71, PTC 1 safe stop

Safe Stop has been activated from the MCB 112 PTC Thermistor Card (motor too warm). Normal operation can be resumed when the MCB 112 applies 24 V DC to T-37 again (when the motor temperature reaches an acceptable level) and when the Digital Input from the MCB 112 is deactivated. When that happens, a reset signal must be sent (via Bus, Digital I/O, or by pressing [Reset]).

ALARM 72, Dangerous failure

Safe Stop with trip lock. An unexpected combination of safe stop commands has occurred:

- VLT PTC Thermistor Card enables X44/10 but safe stop is not enabled.
- MCB 112 is the only device using safe stop (specified through selection [4] or [5] in *5-19 Terminal 37 Safe Stop*), safe stop is activated, and X44/10 is not activated.

WARNING 73, Safe stop auto restart

Safe stopped. With automatic restart enabled, the motor may start when the fault is cleared.

ALARM 74, PTC Thermistor

Alarm related to the ATEX option. The PTC is not working.

ALARM 75, Illegal profile sel.

Parameter value must not be written while motor is running. Stop motor before writing MCO profile to *8-10 Control Word Profile* for instance.

WARNING 76, Power unit setup

The required number of power units does not match the detected number of active power units.

WARNING 77, Reduced power mode

The adjustable frequency drive is operating in reduced power mode (i.e., less than the allowed number of inverter sections). This warning is generated on power cycle when the adjustable frequency drive is set to run with fewer inverters and remains on.

ALARM 78, Tracking error

The difference between setpoint value and actual value has exceeded the value in *4-35 Tracking Error*. Disable the function by *4-34 Tracking Error Function* or select an alarm/warning also in *4-34 Tracking Error Function*. Investigate the mechanics around the load and motor, check feedback connections from motor – encoder – to adjustable frequency drive. Select motor feedback function in *4-30 Motor Feedback Loss Function*. Adjust tracking error band in *4-35 Tracking Error* and *4-37 Tracking Error Ramping*.

ALARM 79, Illegal power section configuration

The scaling card has an incorrect part number or is not installed. The MK102 connector on the power card could not be installed.

ALARM 80, Drive initialized to default value

Parameter settings are initialized to default settings after a manual reset. To clear the alarm, reset the unit.

ALARM 81, CSIV corrupt

CSIV file has syntax errors.

ALARM 82, CSIV parameter error

CSIV failed to init a parameter.

ALARM 83, Illegal option combination

The mounted options are incompatible.

ALARM 84, No safety option

The safety option was removed without applying a general reset. Reconnect the safety option.

ALARM 85, Dang fail PB:

Profibus/Profisafe Error.

ALARM 88, Option detection

A change in the option layout was detected. *14-89 Option Detection* is set to [0] *Frozen configuration* and the option layout has been changed.

- To apply the change, enable option layout changes in *14-89 Option Detection*.
- Alternatively, restore the correct option configuration.

WARNING 89, Mechanical brake sliding

The hoist brake monitor has detected a motor speed > 10 RPM.

ALARM 90, Feedback monitor

Check the connection to encoder/resolver option and eventually replace the MCB 102 or MCB 103.

ALARM 91, Analog input 54 wrong settings

Switch S202 has to be set in position OFF (voltage input) when a KTY sensor is connected to analog input terminal 54.

ALARM 99, Blocked rotor

Rotor is blocked.

WARNING/ALARM 104, Mixing fan fault

The fan is not operating. The fan monitor checks that the fan is spinning at power-up or whenever the mixing fan is turned on. The mixing-fan fault can be configured as a warning or an alarm trip by *14-53 Fan Monitor*.

Troubleshooting

Cycle power to the adjustable frequency drive to determine if the warning/alarm returns.

WARNING/ALARM 122, Mot. rotat. unexp.

The motor is rotating unexpectedly. The adjustable frequency drive is performing a function that requires the motor to be at standstill, for example, DC hold for PM motors.

WARNING 163, ATEX ETR cur.lim.warning

The adjustable frequency drive has exceeded the characteristic curve for more than 50 s. The warning is activated at 83% and de-activated at 65% of the permitted thermal overload.

ALARM 164, ATEX ETR cur.lim.alarm

Operating above the characteristic curve for more than 60 s within a period of 600 s activates the alarm and the frequency converter trips.

WARNING 165, ATEX ETR freq.lim.warning

The frequency converter is running more than 50 s below the permitted minimum frequency (*1-98 ATEX ETR interpol. points freq. [0]*).

ALARM 166, ATEX ETR freq.lim.alarm

The frequency converter has operated more than 60 s (in a period of 600 s) below the permitted minimum frequency (*1-98 ATEX ETR interpol. points freq. [0]*).

ALARM 246, Power card supply

This alarm is only for F Frame frequency converters. It is equivalent to Alarm 46. The report value in the alarm log indicates which power module generated the alarm:

- 1 = left most inverter module.
- 2 = middle inverter module in F2 or F4 frequency converter.
- 2 = right inverter module in F1 or F3 frequency converter.
- 3 = right inverter module in F2 or F4 frequency converter.
- 5 = rectifier module.

WARNING 250, New spare part

A component in the adjustable frequency drive has been replaced. Reset the adjustable frequency drive for normal operation.

WARNING 251, New typecode

The power card or other components have been replaced and the type code changed. Reset to remove the warning and resume normal operation.

7.5 Troubleshooting

Symptom	Possible Cause	Test	Solution
Display dark/No function	Missing input power	See <i>Table 4.5</i> .	Check the input power source.
	Missing or open fuses or circuit breaker tripped	See open fuses and tripped circuit breaker in this table for possible causes.	Follow the recommendations provided.
	No power to the LCP	Check the LCP cable for proper connection or damage.	Replace the faulty LCP or connection cable.
	Shortcut on control voltage (terminal 12 or 50) or at control terminals	Check the 24 V control voltage supply for terminal 12/13 to 20-39 or 10 V supply for terminal 50 to 55.	Wire the terminals properly.
	Wrong LCP (LCP from VLT® 2800 or 5000/6000/8000/ FCD or FCM)		Use only LCP 101 (P/N 130B1124) or LCP 102 (P/N. 130B1107).
	Wrong contrast setting		Press [Status] + ▲/▼ to adjust the contrast.
	Display (LCP) is defective	Test using a different LCP.	Replace the faulty LCP or connection cable.
	Internal voltage supply fault or SMPS is defective		Contact supplier.
Intermittent display	Overloaded power supply (SMPS) due to improper control wiring or a fault within the adjustable frequency drive	To rule out a problem in the control wiring, disconnect all control wiring by removing the terminal blocks.	If the display stays lit, then the problem is in the control wiring. Check the wiring for shorts or incorrect connections. If the display continues to cut out, follow the procedure for display dark.
Motor not running	Service switch open or missing motor connection	Check if the motor is connected and the connection is not interrupted (by a service switch or other device).	Connect the motor and check the service switch.
	No line power with 24 V DC option card	If the display is functioning but no output, check that line power is applied to the adjustable frequency drive.	Apply line power to run the unit.
	LCP Stop	Check if [Off] has been pressed.	Press [Auto On] or [Hand On] (depending on your operation mode) to run the motor.
	Missing start signal (Standby)	Check <i>5-10 Terminal 18 Digital Input</i> for correct setting for terminal 18 (use default setting).	Apply a valid start signal to start the motor.
	Motor coast signal active (Coasting)	Check <i>5-12 Terminal 27 Digital Input</i> for correct setting for terminal 27 (use default setting).	Apply 24 V on terminal 27 or program this terminal to No operation.
	Wrong reference signal source	Check reference signal: Local, remote or bus reference? Preset reference active? Terminal connection correct? Scaling of terminals correct? Reference signal available?	Program correct settings Check <i>3-13 Reference Site</i> Set preset reference active in parameter group <i>3-1* References</i> . Check for correct wiring. Check scaling of terminals. Check reference signal.
Motor running in wrong direction	Motor rotation limit	Check that <i>4-10 Motor Speed Direction</i> is programmed correctly.	Program correct settings.
	Active reversing signal	Check if a reversing command is programmed for the terminal in parameter group <i>5-1* Digital inputs</i> .	Deactivate reversing signal.
	Wrong motor phase connection		See <i>chapter 5.5 Checking Motor Rotation</i> in this manual.

Symptom	Possible Cause	Test	Solution
Motor is not reaching maximum speed	Frequency limits set wrong	Check output limits in 4-13 <i>Motor Speed High Limit [RPM]</i> , 4-14 <i>Motor Speed High Limit [Hz]</i> , and 4-19 <i>Max Output Frequency</i>	Program correct limits.
	Reference input signal not scaled correctly	Check reference input signal scaling in parameter group 6-0* <i>Analog I/O mode</i> and parameter group 3-1* <i>References</i> .	Program correct settings.
Motor speed unstable	Possible incorrect parameter settings	Check the settings of all motor parameters, including all motor compensation settings. For closed-loop operation, check PID settings.	Check settings in parameter group 1-6* <i>Load-Depend.Setta</i> . For closed-loop operation, check settings in parameter group 20-0* <i>Feedback</i> .
Motor runs rough	Possible over-magnetization	Check for incorrect motor settings in all motor parameters.	Check motor settings in parameter groups 1-2* <i>Motor data</i> 1-3* <i>Adv Motor Data</i> , and 1-5* <i>Load Indep. Setting</i> .
Motor will not brake	Possible incorrect settings in the brake parameters. Possible too short ramp-down times.	Check brake parameters. Check ramp time settings.	Check parameter group 2-0* <i>DC Brake</i> and 3-0* <i>Reference Limits</i> .
Open power fuses or circuit breaker trip	Phase-to-phase short	Motor or panel has a short phase-to-phase. Check motor and panel phase for shorts.	Eliminate any shorts detected.
	Motor overload	Motor is overloaded for the application.	Perform start-up test and verify motor current is within specifications. If motor current is exceeding nameplate full load current, motor may run only with reduced load. Review the specifications for the application.
	Loose connections	Perform pre-start-up check for loose connections.	Tighten loose connections.
Line power current imbalance greater than 3%	Problem with line power (See <i>Alarm 4 Line phase loss</i> description)	Rotate input power leads into the drive one position: A to B, B to C, C to A.	If imbalanced leg follows the wire, it is a power problem. Check line power supply.
	Problem with the adjustable frequency drive unit	Rotate input power leads into the adjustable frequency drive one position: A to B, B to C, C to A.	If imbalance leg stays on same input terminal, it is a problem with the unit. Contact supplier.
Motor current imbalance greater than 3%	Problem with motor or motor wiring	Rotate output motor leads one position: U to V, V to W, W to U.	If imbalanced leg follows the wire, the problem is in the motor or motor wiring. Check motor and motor wiring.
	Problem with adjustable frequency drive unit	Rotate output motor leads one position: U to V, V to W, W to U.	If imbalance leg stays on same output terminal, it is a problem with the unit. Contact supplier.
Adjustable frequency drive acceleration problems	Motor data are entered incorrectly	If warnings or alarms occur, see Check that motor data are entered correctly	Increase the ramp-up time in 3-41 <i>Ramp 1 Ramp-up Time</i> . Increase current limit in 4-18 <i>Current Limit</i> . Increase torque limit in 4-16 <i>Torque Limit Motor Mode</i> .
Adjustable frequency drive deceleration problems	Motor data are entered incorrectly	If warnings or alarms occur, see Check that motor data are entered correctly	Increase the ramp-down time in 3-42 <i>Ramp 1 Ramp-down Time</i> . Enable overvoltage control in 2-17 <i>Over-voltage Control</i> .

Table 7.7 Troubleshooting

8 Specifications

8.1 Electrical Data

8.1.1 Line Power Supply 3x200–240 V AC

Type Designation	PK25	PK37	PK55	PK75	P1K1	P1K5	P2K2	P3K0	P3K7
Typical Shaft Output [hp] [kW]	0.34 [0.25]	0.5 [0.37]	0.74 [0.55]	1.0 [0.75]	1.5 [1.1]	2.0 [1.5]	3.0 [2.2]	4.0 [3.0]	5.0 [3.7]
Enclosure IP20 (FC 301 only)	A1	A1	A1	A1	A1	A1	-	-	-
Enclosure IP20/IP21	A2	A2	A2	A2	A2	A2	A2	A3	A3
Enclosure IP55, IP66	A4/A5	A4/A5	A4/A5	A4/A5	A4/A5	A4/A5	A4/A5	A5	A5
Output current									
Continuous (3x200–240 V) [A]	1.8	2.4	3.5	4.6	6.6	7.5	10.6	12.5	16.7
Intermittent (3x200–240 V) [A]	2.9	3.8	5.6	7.4	10.6	12.0	17.0	20.0	26.7
Continuous kVA (208 V AC) [kVA]	0.65	0.86	1.26	1.66	2.38	2.70	3.82	4.50	6.00
Max. input current									
Continuous (3x200–240 V) [A]	1.6	2.2	3.2	4.1	5.9	6.8	9.5	11.3	15.0
Intermittent (3x200–240 V) [A]	2.6	3.5	5.1	6.6	9.4	10.9	15.2	18.1	24.0
Additional Specifications									
Max. cable cross-section ⁴⁾ for line power, motor, brake and load sharing [mm ²] ([AWG])	4,4,4 (12,12,12) (min. 0.2 (24))								
Max. cable cross-section ⁴⁾ for disconnect [mm ²] ([AWG])	6,4,4 (10,12,12)								
Estimated power loss at rated max. load hp [W] ³⁾	0.028 [21]	0.039 [29]	0.057 [42]	0.073 [54]	0.085 [63]	0.111 [82]	0.157 [116]	0.209 [155]	0.250 [185]
Efficiency ²⁾	0.94	0.94	0.95	0.95	0.96	0.96	0.96	0.96	0.96

Table 8.1 Line Power Supply 3x200–240 V AC, PK25-P3K7

Type Designation	P5K5		P7K5		P11K	
High/Normal Overload ¹⁾	HO	NO	HO	NO	HO	NO
Typical Shaft Output [hp] [kW]	7.5 [5.5]	10 [7.5]	10 [7.5]	15 [11]	15 [11]	20 [15]
Enclosure IP20	B3		B3		B4	
Enclosure IP21, IP55, IP66	B1		B1		B2	
Output current						
Continuous (3x200–240 V) [A]	24.2	30.8	30.8	46.2	46.2	59.4
Intermittent (60 s overload) (3x200–240 V) [A]	38.7	33.9	49.3	50.8	73.9	65.3
Continuous kVA (208 V AC) [kVA]	8.7	11.1	11.1	16.6	16.6	21.4
Max. input current						
Continuous (3x200–240 V) [A]	22.0	28.0	28.0	42.0	42.0	54.0
Intermittent (60 s overload) (3x200–240 V) [A]	35.2	30.8	44.8	46.2	67.2	59.4
Additional Specifications						
IP20 max. cable cross-section ⁴⁾ for line power, brake, motor and load sharing [mm ²] ([AWG])	10,10,- (8,8,-)		10,10,- (8,8,-)		35,-,- (2,-,-)	
IP21 max. cable cross-section ⁴⁾ for line power, brake and load sharing [mm ²] ([AWG])	16,10,16 (6,8,6)		16,10,16 (6,8,6)		35,-,- (2,-,-)	
IP21 max. cable cross-section ⁴⁾ for motor [mm ²] ([AWG])	10,10,- (8,8,-)		10,10,- (8,8,-)		35,25,25 (2,4,4)	
Max. cable cross-section ⁴⁾ for Disconnect [mm ²] ([AWG])	16,10,10 (6,8,8)					
Estimated power loss at rated max. load hp [W] ³⁾	0.323 [239]	0.419 [310]	0.501 [371]	0.695 [514]	0.626 [463]	0.814 [602]
Efficiency ²⁾	0.96		0.96		0.96	

Table 8.2 Line Power Supply 3x200–240 V AC, P5K5-P11K

Type Designation	P15K		P18K		P22K		P30K		P37K	
High/Normal Overload ¹⁾	HO	NO	HO	NO	HO	NO	HO	NO	HO	NO
Typical Shaft Output [hp] [kW]	20 [15]	25 [18.5]	25 [18.5]	30 [22]	30 [22]	40 [30]	40 [30]	50 [37]	50 [37]	60 [45]
Enclosure IP20	B4		C3		C3		C4		C4	
Enclosure IP21, IP55, IP66	C1		C1		C1		C2		C2	
Output current										
Continuous (3x200–240 V) [A]	59.4	74.8	74.8	88.0	88.0	115	115	143	143	170
Intermittent (60 s overload) (3x200–240 V) [A]	89.1	82.3	112	96.8	132	127	173	157	215	187
Continuous kVA (208 V AC) [kVA]	21.4	26.9	26.9	31.7	31.7	41.4	41.4	51.5	51.5	61.2
Max. input current										
Continuous (3x200–240 V) [A]	54.0	68.0	68.0	80.0	80.0	104	104	130	130	154
Intermittent (60 s overload) (3x200–240 V) [A]	81.0	74.8	102	88.0	120	114	156	143	195	169
Additional Specifications										
IP20 max. cable cross-section for line power, brake, motor and load sharing [mm ²] ([AWG])	35 (2)		50 (1)		50 (1)		150 (300MCM)		150 (300MCM)	
IP21, IP55, IP66 max. cable cross-section for line power and motor [mm ²] ([AWG])	50 (1)		50 (1)		50 (1)		150 (300MCM)		150 (300MCM)	
IP21, IP55, IP66 max. cable cross-section for brake and load sharing [mm ²] ([AWG])	50 (1)		50 (1)		50 (1)		95 (3/0)		95 (3/0)	
Max. cable cross-section ⁴⁾ for Disconnect [mm ²] ([AWG])	50, 35, 35 (1, 2, 2)						95, 70, 70 (3/0, 2/0, 2/0)		185, 150, 120 (350MCM, 300MCM, 4/0)	
Estimated power loss at rated max. load hp [W] ³⁾	0.843 [624]	0.996 [737]	1.00 [740]	1.142 [845]	1.181 [874]	1.541 [1140]	1.545 [1143]	1.828 [1353]	1.892 [1400]	2.211 [1636]
Efficiency ²⁾	0.96		0.97		0.97		0.97		0.97	

Table 8.3 Line Power Supply 3x200–240 V AC, P15K-P37K

8.1.2 Line Power Supply 3x380–500 V AC

Type Designation	PK37	PK55	PK75	P1K1	P1K5	P2K2	P3K0	P4K0	P5K5	P7K5
Typical Shaft Output [hp] [kW]	0.5 [0.37]	0.74 [0.55]	1.0 [0.75]	1.5 [1.1]	2.0 [1.5]	3.0 [2.2]	4.0 [3.0]	5.0 [4.0]	7.5 [5.5]	10 [7.5]
Enclosure IP20 (FC 301 only)	A1	A1	A1	A1	A1	-	-	-	-	-
Enclosure IP20/IP21	A2	A2	A2	A2	A2	A2	A2	A2	A3	A3
Enclosure IP55, IP66	A4/A5	A4/A5	A4/A5	A4/A5	A4/A5	A4/A5	A4/A5	A4/A5	A5	A5
Output Current High Overload 160% for 1 min										
Shaft output (hp [kW])	0.5 [0.37]	0.74 [0.55]	1 [0.75]	1.5 [1.1]	2.0 [1.5]	3.0 [2.2]	4.0 [3.0]	5.0 [4.0]	7.5 [5.5]	10 [7.5]
Continuous (3x380–440 V) [A]	1.3	1.8	2.4	4.0 [3.0]	4.1	5.6	7.2	10	13	16
Intermittent (3x380–440 V) [A]	2.1	2.9	3.8	4.8	6.6	9.0	11.5	16	20.8	25.6
Continuous (3x441–500 V) [A]	1.2	1.6	2.1	2.7	3.4	4.8	6.3	8.2	11	14.5
Intermittent (3x441–500 V) [A]	1.9	2.6	3.4	4.3	5.4	7.7	10.1	13.1	17.6	23.2
Continuous kVA (400 V AC) [kVA]	0.9	1.3	1.7	2.1	2.8	3.9	5.0	6.9	9.0	11
Continuous kVA (460 V AC) [kVA]	0.9	1.3	1.7	2.4	2.7	3.8	5.0	6.5	8.8	11.6
Max. input current										
Continuous (3x380–440 V) [A]	1.2	1.6	2.2	2.7	3.7	5.0	6.5	9.0	11.7	14.4
Intermittent (3x380–440 V) [A]	1.9	2.6	3.5	4.3	5.9	8.0	10.4	14.4	18.7	23
Continuous (3x441–500 V) [A]	1.0	1.4	1.9	2.7	3.1	4.3	5.7	7.4	9.9	13
Intermittent (3x441–500 V) [A]	1.6	2.2	3.0	4.3	5.0	6.9	9.1	11.8	15.8	20.8
Additional Specifications										
IP20, IP21 max. cable cross-section ⁴⁾ for line power, motor, brake and load sharing [mm ²] ([AWG])	4,4,4 (12,12,12) (min. 0.2(24))									
IP55, IP66 max. cable cross-section ⁴⁾ for line power, motor, brake and load sharing [mm ²] ([AWG])	4,4,4 (12,12,12)									
Max. cable cross-section ⁴⁾ for disconnect [mm ²] ([AWG])	6,4,4 (10,12,12)									
Estimated power loss at rated max. load hp [W] ³⁾	0.047 [35]	0.057 [42]	0.062 [46]	0.078 [58]	0.084 [62]	0.119 [88]	0.157 [116]	0.168 [124]	0.253 [187]	0.345 [255]
Efficiency ²⁾	0.93	0.95	0.96	0.96	0.97	0.97	0.97	0.97	0.97	0.97

Table 8.4 Line Power Supply 3x380–500 V AC (FC 302), 3x380–480 V AC (FC 301), PK37-P7K5

Type Designation	P11K		P15K		P18K		P22K	
High/Normal Overload ¹⁾	HO	NO	HO	NO	HO	NO	HO	NO
Typical Shaft output [kW]	11	15	15	18.5	18.5	22.0	22.0	30.0
Enclosure IP20	B3		B3		B4		B4	
Enclosure IP21	B1		B1		B2		B2	
Enclosure IP55, IP66	B1		B1		B2		B2	
Output current								
Continuous (3x380–440 V) [A]	24	32	32	37.5	37.5	44	44	61
Intermittent (60 s overload) (3x380–440 V) [A]	38.4	35.2	51.2	41.3	60	48.4	70.4	67.1
Continuous (3x441–500 V) [A]	21	27	27	34	34	40	40	52
Intermittent (60 s overload) (3x441–500 V) [A]	33.6	29.7	43.2	37.4	54.4	44	64	57.2
Continuous kVA (400 V AC) [kVA]	16.6	22.2	22.2	26	26	30.5	30.5	42.3
Continuous kVA (460 V AC) [kVA]		21.5		27.1		31.9		41.4
Max. input current								
Continuous (3x380–440 V) [A]	22	29	29	34	34	40	40	55
Intermittent (60 s overload) (3x380–440 V) [A]	35.2	31.9	46.4	37.4	54.4	44	64	60.5
Continuous (3x441–500 V) [A]	19	25	25	31	31	36	36	47
Intermittent (60 s overload) (3x441–500 V) [A]	30.4	27.5	40	34.1	49.6	39.6	57.6	51.7
Additional specifications								
IP21, IP55, IP66 max. cable cross-section ⁴⁾ for line power, brake and load sharing [mm ²] ([AWG])	16, 10, 16 (6, 8, 6)		16, 10, 16 (6, 8, 6)		35,-,-(2,-,-)		35,-,-(2,-,-)	
IP21, IP55, IP66 max. cable cross-section ⁴⁾ for motor [mm ²] ([AWG])	10, 10,- (8, 8,-)		10, 10,- (8, 8,-)		35, 25, 25 (2, 4, 4)		35, 25, 25 (2, 4, 4)	
IP20 max. cable cross-section ⁴⁾ for line power, brake, motor and load sharing [mm ²] ([AWG])	10, 10,- (8, 8,-)		10, 10,- (8, 8,-)		35,-,-(2,-,-)		35,-,-(2,-,-)	
Max. cable cross-section ⁴⁾ for Disconnect [mm ²] ([AWG])	16, 10, 10 (6, 8, 8)							
Estimated power loss at rated max. load hp [W] ³⁾	0.393 [291]	0.530 [392]	0.512 [379]	0.628 [465]	0.600 [444]	0.709 [525]	0.739 [547]	0.999 [739]
Efficiency ²⁾	0.98		0.98		0.98		0.98	

Table 8.5 Line Power Supply 3x380–500 V AC (FC 302), 3x380–480 V AC (FC 301), P11K-P22K

Type Designation	P30K		P37K		P45K		P55K		P75K	
	HO	NO	HO	NO	HO	NO	HO	NO	HO	NO
High/Normal Overload ¹⁾										
Typical Shaft output hp [kW]	40 [30]	50 [37]	50 [37]	60 [45]	60 [45]	75 [55]	75 [55]	100 [75]	100 [75]	125 [90]
Enclosure IP21	C1		C1		C1		C2		C2	
Enclosure IP20	B4		C3		C3		C4		C4	
Enclosure IP55, IP66	C1		C1		C1		C2		C2	
Output current										
Continuous (3x380–440 V) [A]	61	73	73	90	90	106	106	147	147	177
Intermittent (60 s overload) (3x380–440 V) [A]	91.5	80.3	110	99	135	117	159	162	221	195
Continuous (3x441–500 V) [A]	52	65	65	80	80	105	105	130	130	160
Intermittent (60 s overload) (3x441–500 V) [A]	78	71.5	97.5	88	120	116	158	143	195	176
Continuous kVA (400 V AC) [kVA]	42.3	50.6	50.6	62.4	62.4	73.4	73.4	102	102	123
Continuous kVA (460 V AC) [kVA]		51.8		63.7		83.7		104		128
Max. input current										
Continuous (3x380–440 V) [A]	55	66	66	82	82	96	96	133	133	161
Intermittent (60 s overload) (3x380–440 V) [A]	82.5	72.6	99	90.2	123	106	144	146	200	177
Continuous (3x441–500 V) [A]	47	59	59	73	73	95	95	118	118	145
Intermittent (60 s overload) (3x441–500 V) [A]	70.5	64.9	88.5	80.3	110	105	143	130	177	160
Additional specifications										
IP20 max. cable cross-section for line power and motor [mm ²] ([AWG])	35 (2)		50 (1)		50 (1)		150 (300 MCM)		150 (300 MCM)	
IP20 max. cable cross-section for brake and load sharing [mm ²] ([AWG])	35 (2)		50 (1)		50 (1)		95 (4/0)		95 (4/0)	
IP21, IP55, IP66 max. cable cross- section for line power and motor [mm ²] ([AWG])	50 (1)		50 (1)		50 (1)		150 (300 MCM)		150 (300MCM)	
IP21, IP55, IP66 max. cable cross- section for brake and load sharing [mm ²] ([AWG])	50 (1)		50 (1)		50 (1)		95 (3/0)		95 (3/0)	
Max cable cross-section ⁴⁾ for line power disconnect [mm ²] ([AWG])			50, 35, 35 (1, 2, 2)				95, 70, 70 (3/0, 2/0, 2/0)		185, 150, 120 (350 MCM, 300 MCM, 4/0)	
Estimated power loss at rated max. load hp [W] ³⁾	0.770 [570]	0.943 [698]	0.942 [697]	1.139 [843]	1.204 [891]	1.464 [1083]	1.381 [1022]	1.870 [1384]	1.665 [1232]	1.992 [1474]
Efficiency ²⁾	0.98		0.98		0.98		0.98		0.99	

Table 8.6 Line Power Supply 3x380–500 V AC (FC 302), 3x380–480 V AC (FC 301), P30K-P75K

8.1.3 Line Power Supply 3x525–600 V AC (FC 302 only)

Type Designation	PK75	P1K1	P1K5	P2K2	P3K0	P4K0	P5K5	P7K5
Typical Shaft Output [hp] [kW]	1 [0.75]	1.5 [1.1]	2.0 [1.5]	3.0 [2.2]	4.0 [3.0]	5.0 [4.0]	7.5 [5.5]	10 [7.5]
Enclosure IP20, IP21	A3	A3	A3	A3	A3	A3	A3	A3
Enclosure IP55	A5	A5	A5	A5	A5	A5	A5	A5
Output current								
Continuous (3 x 525–550 V) [A]	1.8	2.6	2.9	4.1	5.2	6.4	9.5	11.5
Intermittent (3 x 525–550 V) [A]	2.9	4.2	4.6	6.6	8.3	10.2	15.2	18.4
Continuous (3x551–600 V) [A]	1.7	2.4	2.7	3.9	4.9	6.1	9.0	11.0
Intermittent (3x551–600 V) [A]	2.7	3.8	4.3	6.2	7.8	9.8	14.4	17.6
Continuous kVA (525 V AC) [kVA]	1.7	2.5	2.8	3.9	5.0	6.1	9.0	11.0
Continuous kVA (575 V AC) [kVA]	1.7	2.4	2.7	3.9	4.9	6.1	9.0	11.0
Max. input current								
Continuous (3x525–600 V) [A]	1.7	2.4	2.7	4.1	5.2	5.8	8.6	10.4
Intermittent (3x525–600 V) [A]	2.7	3.8	4.3	6.6	8.3	9.3	13.8	16.6
Additional specifications								
Max. cable cross-section ⁴⁾ for line power, motor, brake and load sharing [mm ²] ([AWG])	4,4,4 (12,12,12) (min. 0.2 (24))							
Max. cable cross-section ⁴⁾ for disconnect [mm ²] ([AWG])	6,4,4 (10,12,12)							
Estimated power loss at rated max. load hp [W] ³⁾	0.047 [35]	0.068 [50]	0.088 [65]	0.124 [92]	0.165 [122]	0.196 [145]	0.264 [195]	0.353 [261]
Efficiency ²⁾	0.97	0.97	0.97	0.97	0.97	0.97	0.97	0.97

Table 8.7 Line Power Supply 3x525–600 V AC (FC 302 only), PK75-P7K5

Type Designation	P11K		P15K		P18K		P22K		P30K	
	HO	NO	HO	NO	HO	NO	HO	NO	HO	NO
High/Normal Overload ¹⁾										
Typical Shaft Output [hp] [kW]	0.015 [11]	0.020 [15]	0.020 [15]	25 [18.5]	25 [18.5]	30 [22]	30 [22]	40 [30]	40 [30]	50 [37]
Enclosure IP20	B3		B3		B4		B4		B4	
Enclosure IP21, IP55, IP66	B1		B1		B2		B2		C1	
Output current										
Continuous (3 x 525–550 V) [A]	19	23	23	28	28	36	36	43	43	54
Intermittent (3 x 525–550 V) [A]	30	25	37	31	45	40	58	47	65	59
Continuous (3x551–600 V) [A]	18	22	22	27	27	34	34	41	41	52
Intermittent (3x551–600 V) [A]	29	24	35	30	43	37	54	45	62	57
Continuous kVA (550 V AC) [kVA]	18.1	21.9	21.9	26.7	26.7	34.3	34.3	41.0	41.0	51.4
Continuous kVA (575 V AC) [kVA]	17.9	21.9	21.9	26.9	26.9	33.9	33.9	40.8	40.8	51.8
Max. input current										
Continuous at 550 V [A]	17.2	20.9	20.9	25.4	25.4	32.7	32.7	39	39	49
Intermittent at 550 V [A]	28	23	33	28	41	36	52	43	59	54
Continuous at 575 V [A]	16	20	20	24	24	31	31	37	37	47
Intermittent at 575 V [A]	26	22	32	27	39	34	50	41	56	52
Additional specifications										
IP20 max. cable cross-section ⁴⁾ for line power, brake, motor and load sharing [mm ²] ([AWG])	10, 10,- (8, 8,-)		10, 10,- (8, 8,-)		35,-,-(2,-,-)		35,-,-(2,-,-)		35,-,-(2,-,-)	
IP21, IP55, IP66 max. cable cross-section ⁴⁾ for line power, brake and load sharing [mm ²] ([AWG])	16, 10, 10 (6, 8, 8)		16, 10, 10 (6, 8, 8)		35,-,-(2,-,-)		35,-,-(2,-,-)		50,-,- (1,-,-)	
IP21, IP55, IP66 max. cable cross-section ⁴⁾ for motor [mm ²] ([AWG])	10, 10,- (8, 8,-)		10, 10,- (8, 8,-)		35, 25, 25 (2, 4, 4)		35, 25, 25 (2, 4, 4)		50,-,- (1,-,-)	
Max. cable cross-section ⁴⁾ for Disconnect [mm ²] ([AWG])	16, 10, 10 (6, 8, 8)								50, 35, 35 (1, 2, 2)	
Estimated power loss at rated max. load hp [W] ³⁾	0.297 [220]	0.405 [300]	0.405 [300]	0.500 [370]	0.500 [370]	0.595 [440]	0.595 [440]	0.811 [600]	0.811 [600]	1.00 [740]
Efficiency ²⁾	0.98		0.98		0.98		0.98		0.98	

Table 8.8 Line Power Supply 3x525–600 V AC (FC 302 only), P11K-P30K

Type Designation	P37K		P45K		P55K		P75K	
High/Normal Overload ¹⁾	HO	NO	HO	NO	HO	NO	HO	NO
Typical Shaft Output [hp] [kW]	50 [37]	60 [45]	60 [45]	75 [55]	75 [55]	100 [75]	100 [75]	125 [90]
Enclosure IP20	C3	C3	C3		C4		C4	
Enclosure IP21, IP55, IP66	C1	C1	C1		C2		C2	
Output current								
Continuous (3 x 525–550 V) [A]	54	65	65	87	87	105	105	137
Intermittent (3 x 525–550 V) [A]	81	72	98	96	131	116	158	151
Continuous (3x551–600 V) [A]	52	62	62	83	83	100	100	131
Intermittent (3x551–600 V) [A]	78	68	93	91	125	110	150	144
Continuous kVA (550 V AC) [kVA]	51.4	61.9	61.9	82.9	82.9	100.0	100.0	130.5
Continuous kVA (575 V AC) [kVA]	51.8	61.7	61.7	82.7	82.7	99.6	99.6	130.5
Max. input current								
Continuous at 550 V [A]	49	59	59	78.9	78.9	95.3	95.3	124.3
Intermittent at 550 V [A]	74	65	89	87	118	105	143	137
Continuous at 575 V [A]	47	56	56	75	75	91	91	119
Intermittent at 575 V [A]	70	62	85	83	113	100	137	131
Additional specifications								
IP20 max. cable cross-section for line power and motor [mm ²] ([AWG])	50 (1)				150 (300 MCM)			
IP20 max. cable cross-section for brake and load sharing [mm ²] ([AWG])	50 (1)				95 (4/0)			
IP21, IP55, IP66 max. cable cross-section for line power and motor [mm ²] ([AWG])	50 (1)				150 (300 MCM)			
IP21, IP55, IP66 max. cable cross-section for brake and load sharing [mm ²] ([AWG])	50 (1)				95 (4/0)			
Max cable cross-section ⁴⁾ for line power disconnect [mm ²] ([AWG])	50, 35, 35 (1, 2, 2)				95, 70, 70 (3/0, 2/0, 2/0)		185, 150, 120 (350MCM, 300MCM, 4/0)	
Estimated power loss at rated max. load hp [W] ³⁾	1.00 [740]	1.216 [900]	1.216 [900]	1.486 [1100]	1.486 [1100]	2.027 [1500]	2.027 [1500]	2.432 [1800]
Efficiency ²⁾	0.98		0.98		0.98		0.98	

Table 8.9 Line Power Supply 3x525–600 V AC (FC 302 only), P37K-P75K

8.1.4 Line Power Supply 3x525–690 V AC (FC 302 only)

Type Designation	P1K1	P1K5	P2K2	P3K0	P4K0	P5K5	P7K5
High/Normal Overload ¹⁾	HO/NO	HO/NO	HO/NO	HO/NO	HO/NO	HO/NO	HO/NO
Typical Shaft output hp [kW]	1.5 [1.1]	2.0 [1.5]	3.0 [2.2]	4.0 [3.0]	5.0 [4.0]	7.5 [5.5]	10 [7.5]
Enclosure IP20	A3	A3	A3	A3	A3	A3	A3
Output current							
Continuous (3x525–550 V) [A]	2.1	2.7	3.9	4.9	6.1	9.0	11.0
Intermittent (3x525–550 V) [A]	3.4	4.3	6.2	7.8	9.8	14.4	17.6
Continuous (3x551–690 V) [A]	1.6	2.2	3.2	4.5	5.5	7.5	10.0
Intermittent (3x551–690 V) [A]	2.6	3.5	5.1	7.2	8.8	12.0	16.0
Continuous KVA 525 V AC	1.9	2.5	3.5	4.5	5.5	8.2	10.0
Continuous KVA 690 V AC	1.9	2.6	3.8	5.4	6.6	9.0	12.0
Max. input current							
Continuous (3x525–550 V) [A]	1.9	2.4	3.5	4.4	5.5	8.1	9.9
Intermittent (3x525–550 V) [A]	3.0	3.9	5.6	7.0	8.8	12.9	15.8
Continuous (3x551–690 V) [A]	1.4	2.0	2.9	4.0	4.9	6.7	9.0
Intermittent (3x551–690 V) [A]	2.3	3.2	4.6	6.5	7.9	10.8	14.4
Additional specifications							
Max. cable cross-section ⁴⁾ for line power, motor, brake and load sharing [mm ²] ([AWG])	4, 4, 4 (12, 12, 12) (min. 0.2 (24))						
Max. Cable cross-section ⁴⁾ for disconnect [mm ²] ([AWG])	6, 4, 4 (10, 12, 12)						
Estimated power loss at rated max. load (W) ³⁾	0.059 [44]	0.081 [60]	0.119 [88]	0.162 [120]	0.216 [160]	0.297 [220]	0.405 [300]
Efficiency ²⁾	0.96	0.96	0.96	0.96	0.96	0.96	0.96

Table 8.10 A3 Enclosure, Line Power Supply 3x525–690 V AC IP20/Protected Chassis, P1K1-P7K5

Type Designation	P11K		P15K		P18K		P22K	
	HO	NO	HO	NO	HO	NO	HO	NO
High/Normal Overload ¹⁾								
Typical Shaft output at 550 V hp [kW]	10 [7.5]	15 [11]	15 [11]	20 [15]	20 [15]	25 [18.5]	25 [18.5]	30 [22]
Typical Shaft output at 690 V hp [kW]	15 [11]	20 [15]	20 [15]	25 [18.5]	25 [18.5]	30 [22]	30 [22]	40 [30]
Enclosure IP20	B4		B4		B4		B4	
Enclosure IP21, IP55	B2		B2		B2		B2	
Output current								
Continuous (3x525–550 V) [A]	14.0	19.0	19.0	23.0	23.0	28.0	28.0	36.0
Intermittent (60 s overload) (3x525–550 V) [A]	22.4	20.9	30.4	25.3	36.8	30.8	44.8	39.6
Continuous (3x551–690 V) [A]	13.0	18.0	18.0	22.0	22.0	27.0	27.0	34.0
Intermittent (60 s overload) (3x551–690 V) [A]	20.8	19.8	28.8	24.2	35.2	29.7	43.2	37.4
continuous KVA (at 550 V) [KVA]	13.3	18.1	18.1	21.9	21.9	26.7	26.7	34.3
continuous KVA (at 690 V AC) [KVA]	15.5	21.5	21.5	26.3	26.3	32.3	32.3	40.6
Max. input current								
Continuous (at 550 V) (A)	15.0	19.5	19.5	24.0	24.0	29.0	29.0	36.0
Intermittent (60 s overload) (at 550 V) (A)	23.2	21.5	31.2	26.4	38.4	31.9	46.4	39.6
Continuous (at 690 V) (A)	14.5	19.5	19.5	24.0	24.0	29.0	29.0	36.0
Intermittent (60 s overload) (at 690 V) (A)	23.2	21.5	31.2	26.4	38.4	31.9	46.4	39.6
Additional specifications								
Max. cable cross-section ⁴⁾ for line power/motor, load share and brake [mm ²] ([AWG])	35, 25, 25 (2, 4, 4)							
Max cable cross-section ⁴⁾ for line power disconnect [mm ²] ([AWG])	16,10,10 (6, 8, 8)							
Estimated power loss at rated max. load hp (W) ³⁾	0.203 [150]	0.297 [220]	0.297 [220]	0.405 [300]	0.405 [300]	0.500 [370]	0.500 [370]	0.595 [440]
Efficiency ²⁾	0.98		0.98		0.98		0.98	

Table 8.11 B2/B4 Enclosure, Line Power Supply 3x525–690 V AC IP20/IP21/IP55 - Chassis/NEMA 1/NEMA 12 (FC 302 only), P11K-P22K

Type Designation	P30K		P37K		P45K		P55K		P75K	
	HO	NO	HO	NO	HO	NO	HO	NO	HO	NO
High/Normal Overload ¹⁾										
Typical Shaft output at 550 V hp (kW)	30 [22]	40 [30]	40 [30]	50 [37]	50 [37]	60 [45]	60 [45]	75 [55]	68 [50]	100 [75]
Typical Shaft output at 690 V hp [kW]	40 [30]	50 [37]	50 [37]	60 [45]	60 [45]	75 [55]	75 [55]	100 [75]	100 [75]	125 [90]
Enclosure IP20	B4		C3		C3		D3h		D3h	
Enclosure IP21, IP55	C2		C2		C2		C2		C2	
Output current										
Continuous (3x525–550 V) [A]	36.0	43.0	43.0	54.0	54.0	65.0	65.0	87.0	87.0	105
Intermittent (60 s overload) (3x525–550 V) [A]	54.0	47.3	64.5	59.4	81.0	71.5	97.5	95.7	130.5	115.5
Continuous (3x551–690 V) [A]	34.0	41.0	41.0	52.0	52.0	62.0	62.0	83.0	83.0	100
Intermittent (60 s overload) (3x551–690 V) [A]	51.0	45.1	61.5	57.2	78.0	68.2	93.0	91.3	124.5	110
continuous KVA (at 550 V AC) [KVA]	34.3	41.0	41.0	51.4	51.4	61.9	61.9	82.9	82.9	100
continuous KVA (at 690 V AC) [KVA]	40.6	49.0	49.0	62.1	62.1	74.1	74.1	99.2	99.2	119.5
Max. input current										
Continuous (at 550 V) [A]	36.0	49.0	49.0	59.0	59.0	71.0	71.0	87.0	87.0	99.0
Intermittent (60 s overload) (at 550 V) [A]	54.0	53.9	72.0	64.9	87.0	78.1	105.0	95.7	129	108.9
Continuous (at 690 V) [A]	36.0	48.0	48.0	58.0	58.0	70.0	70.0	86.0	-	-
Intermittent (60 s overload) (at 690 V) [A]	54.0	52.8	72.0	63.8	87.0	77.0	105	94.6	-	-
Additional specifications										
Max. cable-cross section for line power and motor [mm ²] ([AWG])	150 (300 MCM)									
Max. cable cross-section for load share and brake [mm ²] ([AWG])	95 (3/0)									
Max cable cross-section ⁴⁾ for line power disconnect [mm ²] ([AWG])	95, 70, 70 (3/0, 2/0, 2/0)						185, 150, 120 (350 MCM, 300 MCM, 4/0)		-	
Estimated power loss at rated max. load hp [W] ³⁾	0.811 [600]	1.00 [740]	1.00 [740]	1.216 [900]	1.216 [900]	1.486 [1100]	1.486 [1100]	2.027 [1500]	2.027 [1500]	2.432 [1800]
Efficiency ²⁾	0.98		0.98		0.98		0.98		0.98	

Table 8.12 B4, C2, C3 Enclosure, Line Power Supply 3x525–690 V AC IP20/IP21/IP55 - Chassis/NEMA1/NEMA 12 (FC 302 only), P30K-P75K

For fuse ratings, see chapter 8.7 Fuses and Circuit Breakers.

¹⁾ High overload=150% or 160% torque during 60 s. Normal overload=110% torque during 60 s.

²⁾ Measured using 16.5 ft. [5 m] shielded motor cables at rated load and rated frequency.

³⁾ The typical power loss is at nominal load conditions and expected to be within ±15% (tolerance relates to variety in voltage and cable conditions).

Values are based on a typical motor efficiency (eff2/eff3 border line). Motors with lower efficiency will also add to the power loss in the adjustable frequency drive and vice-versa.

If the switching frequency is increased compared to the default setting, the power losses may rise significantly.

LCP and typical control card power consumption values are included. Further options and customer load may add up to 30 W to the losses. (Though typical only 4 W extra for a fully loaded control card, or options for slot A or slot B, each).

Although measurements are made with state of the art equipment, some measurement inaccuracy must be allowed for (± 5%).

⁴⁾ The three values for the max. cable cross-section are for single core, flexible wire and flexible wire with sleeve, respectively.

8.2 Line Power Supply

Line power supply

Supply Terminals (6-pulse)	L1, L2, L3
Supply Terminals (12-pulse)	L1-1, L2-1, L3-1, L1-2, L2-2, L3-2
Supply voltage	200–240 V ±10%
Supply voltage	FC 301: 380–480 V/FC 302: 380–500 V ±10%
Supply voltage	FC 302: 525–600 V ±10%
Supply voltage	FC 302: 525–690 V ±10%

AC line voltage low/line drop-out:

During low AC line voltage or a line drop-out, the adjustable frequency drive continues until the intermediate circuit voltage drops below the minimum stop level, which corresponds typically to 15% below the adjustable frequency drive's lowest rated supply voltage. Power-up and full torque cannot be expected at AC line voltage lower than 10% below the adjustable frequency drive's lowest rated supply voltage.

Supply frequency	50/60 Hz ±5%
Max. temporary imbalance between line phases	3.0% of rated supply voltage
True Power Factor (λ)	≥ 0.9 nominal at rated load
Displacement Power Factor ($\cos \phi$)	near unity (> 0.98)
Switching on input supply L1, L2, L3 (power-ups) ≤ 7.5 kW	maximum 2 times/min.
Switching on input supply L1, L2, L3 (power-ups) 11–75 kW	maximum 1 time/min.
Switching on input supply L1, L2, L3 (power-ups) ≥ 90 kW	Maximum 1 time/2 min.
Environment according to EN60664-1	overvoltage category III/pollution degree 2

The unit is suitable for use on a circuit capable of delivering not more than 100,000 RMS symmetrical Amperes, 240/500/600/690 V maximum.

8.3 Motor Output and Motor Data

Motor output (U, V, W¹)

Output voltage	0–100% of supply voltage
Output frequency	0–590 Hz
Output frequency in flux mode	0–300 Hz
Switching on output	Unlimited
Ramp times	0.01–3600 s

Torque characteristics

Starting torque (constant torque)	maximum 160% for 60 s ¹ once in 10 min.
Starting/overload torque (variable torque)	maximum 110% up to 0.5 s ¹ once in 10 min.
Torque rise time in FLUX (for 5 kHz fsw)	1 ms
Torque rise time in VVC ^{plus} (independent of fsw)	10 ms

¹ Percentage relates to the nominal torque.

² The torque response time depends on application and load but as a general rule, the torque step from 0 to reference is 4–5 x torque rise time.

8.4 Ambient Conditions

Environment

Enclosure	IP20/Chassis, IP21/Type 1, IP55/ Type 12, IP66/ Type 4X
Vibration test	1.0 g
Max. THVD	10%
Max. relative humidity	5%–93% (IEC 721-3-3; Class 3K3 (non-condensing) during operation
Aggressive environment (IEC 60068-2-43) H ₂ S test	class Kd
Ambient temperature ¹⁾	Max. 122 °F [50 °C] (24-hour average maximum 113 °F [45 °C])
Minimum ambient temperature during full-scale operation	32 °F [0 °C]
Minimum ambient temperature at reduced performance	14 °F [-10 °C]
Temperature during storage/transport	-13 to +49/158 °F [-25 to +65/70 °C]
Maximum altitude above sea level without derating	3300 ft [1000 m]

Derating for high altitude, see special conditions in the Design Guide.

EMC standards, Emission	EN 61800-3
EMC standards, Immunity	EN 61800-3

See section on special conditions in the Design Guide..

¹⁾ *Derating for high ambient temperature, see special conditions in the Design Guide*

8

8.5 Cable Specifications

Cable lengths and cross-sections for control cables¹⁾

Max. motor cable length, shielded	500 ft [150 m]
Max. motor cable length, non-shielded	1000 ft [300 m]
Maximum cross-section to control terminals, flexible/rigid wire without cable end sleeves	1.5 mm ² /16 AWG
Maximum cross-section to control terminals, flexible wire with cable end sleeves	1 mm ² /18 AWG
Maximum cross-section to control terminals, flexible wire with cable end sleeves with collar	0.5 mm ² /20 AWG
Minimum cross-section to control terminals	0.25 mm ² /24 AWG

¹⁾*For power cables, see electrical tables in chapter 8.1 Electrical Data.*

8.6 Control Input/Output and Control Data

Digital inputs

Programmable digital inputs	FC 301: 4 (5) ¹⁾ /FC 302: 4 (6) ¹⁾
Terminal number	18, 19, 27 ¹⁾ , 29 ¹⁾ , 32, 33,
Logic	PNP or NPN
Voltage level	0–24 V DC
Voltage level, logic '0' PNP	< 5 V DC
Voltage level, logic '1' PNP	> 10 V DC
Voltage level, logic '0' NPN ²⁾	> 19 V DC
Voltage level, logic '1' NPN ²⁾	< 14 V DC
Maximum voltage on input	28 V DC
Pulse frequency ranges	0–110 kHz
(Duty cycle) Min. pulse width	4.5 ms
Input resistance, R _i	Approx. 4 kΩ

Safe stop Terminal 37^{3), 4)} (Terminal 37 is fixed PNP logic)

Voltage level	0–24 V DC
Voltage level, logic '0' PNP	<4 V DC
Voltage level, logic '1' PNP	>20 V DC
Maximum voltage on input	28 V DC
Typical input current at 24 V	50 mA rms
Typical input current at 20 V	60 mA rms
Input capacitance	400 nF

All digital inputs are galvanically isolated from the supply voltage (PELV) and other high-voltage terminals.

¹⁾ Terminals 27 and 29 can also be programmed as output.

²⁾ Except safe stop input Terminal 37.

³⁾ See for further information about terminal 37 and Safe Stop.

⁴⁾ When using a contactor with a DC coil inside in combination with Safe Stop, it is important to make a return way for the current from the coil when turning it off. This can be done by using a freewheel diode (or, alternatively, a 30 or 50 V MOV for quicker response time) across the coil. Typical contactors can be bought with this diode.

Analog inputs

Number of analog inputs	2
Terminal number	53, 54
Modes	Voltage or current
Mode select	Switch S201 and switch S202
Voltage mode	Switch S201/switch S202 = OFF (U)
Voltage level	-10 to +10 V (scaleable)
Input resistance, R_i	approx. 10 k Ω
Max. voltage	± 20 V
Current mode	Switch S201/switch S202 = ON (I)
Current level	0/4 to 20 mA (scaleable)
Input resistance, R_i	approx. 200 Ω
Max. current	30 mA
Resolution for analog inputs	10 bit (+ sign)
Accuracy of analog inputs	Max. error 0.5% of full scale
Bandwidth	100 Hz

The analog inputs are galvanically isolated from the supply voltage (PELV) and other high-voltage terminals.

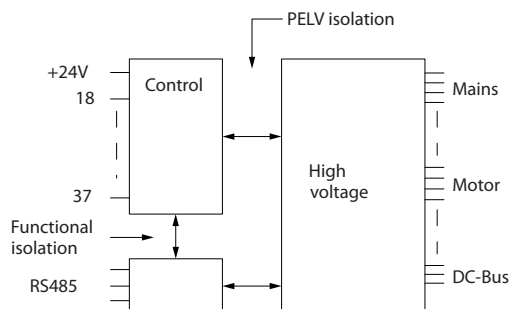

Figure 8.1 PELV Isolation

Pulse/encoder inputs

Programmable pulse/encoder inputs	2/1
Terminal number pulse/encoder	29 ¹⁾ , 33 ²⁾ / 32 ³⁾ , 33 ³⁾
Max. frequency at terminal 29, 32, 33	110 kHz (push-pull driven)
Max. frequency at terminal 29, 32, 33	5 kHz (open collector)
Min. frequency at terminal 29, 32, 33	4 Hz
Voltage level	see section on Digital input
Maximum voltage on input	28 V DC
Input resistance, R_i	approx. 4 k Ω
Pulse input accuracy (0.1–1 kHz)	Max. error: 0.1% of full scale
Encoder input accuracy (1–11 kHz)	Max. error: 0.05% of full scale

The pulse and encoder inputs (terminals 29, 32, 33) are galvanically isolated from the supply voltage (PELV) and other high-voltage terminals.

¹⁾ FC 302 only

²⁾ Pulse inputs are 29 and 33

³⁾ Encoder inputs: 32 = A, and 33 = B

Digital output

Programmable digital/pulse outputs	2
Terminal number	27, 29 ¹⁾
Voltage level at digital/frequency output	0–24 V
Max. output current (sink or source)	40 mA
Max. load at frequency output	1 k Ω
Max. capacitive load at frequency output	10 nF
Minimum output frequency at frequency output	0 Hz
Maximum output frequency at frequency output	32 kHz
Accuracy of frequency output	Max. error: 0.1% of full scale
Resolution of frequency outputs	12 bit

¹⁾ Terminal 27 and 29 can also be programmed as input.

The digital output is galvanically isolated from the supply voltage (PELV) and other high-voltage terminals.

Analog output

Number of programmable analog outputs	1
Terminal number	42
Current range at analog output	0/4 to 20 mA
Max. load GND - analog output less than	500 Ω
Accuracy on analog output	Max. error: 0.5% of full scale
Resolution on analog output	12 bit

The analog output is galvanically isolated from the supply voltage (PELV) and other high-voltage terminals.

Control card, 24 V DC output

Terminal number	12, 13
Output voltage	24 V +1, -3 V
Max. load	200 mA

The 24 V DC supply is galvanically isolated from the supply voltage (PELV), but has the same potential as the analog and digital inputs and outputs.

Control card, 10 V DC output

Terminal number	± 50
Output voltage	10.5 V ± 0.5 V
Max. load	15 mA

The 10 V DC supply is galvanically isolated from the supply voltage (PELV) and other high-voltage terminals.

Control card, RS-485 serial communication

Terminal number	68 (P,TX+, RX+), 69 (N,TX-, RX-)
Terminal number 61	Common for terminals 68 and 69

The RS-485 serial communication circuit is functionally separated from other central circuits and galvanically isolated from the supply voltage (PELV).

Control card, USB serial communication

USB standard	1.1 (Full speed)
USB plug	USB type B "device" plug

Connection to PC is carried out via a standard host/device USB cable.

The USB connection is galvanically isolated from the supply voltage (PELV) and other high-voltage terminals.

The USB ground connection is not galvanically isolated from protection ground. Use only an isolated laptop as PC connection to the USB connector on the adjustable frequency drive.

Relay outputs

Programmable relay outputs	FC 301 all kW: 1/FC 302 all kW: 2
Relay 01 Terminal number	1-3 (break), 1-2 (make)
Max. terminal load (AC-1) ¹⁾ on 1-3 (NC), 1-2 (NO) (Resistive load)	240 V AC, 2 A
Max. terminal load (AC-15) ¹⁾ (Inductive load @ cosφ 0.4)	240 V AC, 0.2 A
Max. terminal load (DC-1) ¹⁾ on 1-2 (NO), 1-3 (NC) (Resistive load)	60 V DC, 1 A
Max. terminal load (DC-13) ¹⁾ (Inductive load)	24 V DC, 0.1 A
Relay 02 (FC 302 only) Terminal number	4-6 (break), 4-5 (make)
Max. terminal load (AC-1) ¹⁾ on 4-5 (NO) (Resistive load) ²⁾³⁾ Overvoltage cat. II	400 V AC, 2 A
Max. terminal load (AC-15) ¹⁾ on 4-5 (NO) (Inductive load @ cosφ 0.4)	240 V AC, 0.2 A
Max. terminal load (DC-1) ¹⁾ on 4-5 (NO) (Resistive load)	80 V DC, 2 A
Max. terminal load (DC-13) ¹⁾ on 4-5 (NO) (Inductive load)	24 V DC, 0.1 A
Max. terminal load (AC-1) ¹⁾ on 4-6 (NC) (Resistive load)	240 V AC, 2 A
Max. terminal load (AC-15) ¹⁾ on 4-6 (NC) (Inductive load @ cosφ 0.4)	240 V AC, 0.2 A
Max. terminal load (DC-1) ¹⁾ on 4-6 (NC) (Resistive load)	50 V DC, 2 A
Max. terminal load (DC-13) ¹⁾ on 4-6 (NC) (Inductive load)	24 V DC, 0.1 A
Min. terminal load on 1-3 (NC), 1-2 (NO), 4-6 (NC), 4-5 (NO)	24 V DC 10 mA, 24 V AC 20 mA
Environment according to EN 60664-1	overvoltage category III/pollution degree 2

¹⁾ IEC 60947 part 4 and 5

The relay contacts are galvanically isolated from the rest of the circuit by reinforced isolation (PELV).

²⁾ Overvoltage Category II

³⁾ UL applications 300 V AC2A

Control card performance

Scan interval	1 ms
---------------	------

Control characteristics

Resolution of output frequency at 0–590 Hz	±0.003 Hz
Repeat accuracy of Precise start/stop (terminals 18, 19)	≤±0.1 ms
System response time (terminals 18, 19, 27, 29, 32, 33)	≤ 2 ms
Speed control range (open-loop)	1:100 of synchronous speed
Speed control range (closed-loop)	1:1000 of synchronous speed
Speed accuracy (open-loop)	30–4000 rpm: error ±8 rpm
Speed accuracy (closed-loop), depending on resolution of feedback device	0–6000 rpm: error ±0.15 rpm
Torque control accuracy (speed feedback)	max error ±5% of rated torque

All control characteristics are based on a 4-pole asynchronous motor

8.7 Fuses and Circuit Breakers

Use recommended fuses and/or circuit breakers on the supply side as protection in case of component breakdown inside the adjustable frequency drive (first fault).

NOTICE!

Use of fuses on the supply side is mandatory for IEC 60364 (CE) and NEC 2009 (UL) compliant installations.

Recommendations

- Fuses of the type gG
- Circuit breakers of Moeller types. By use of other circuit breaker types, ensure that the energy into the adjustable frequency drive is equal to or lower than the energy provided by Moeller types.

If fuses/circuit breakers according to recommendations are chosen, possible damage on the adjustable frequency drive will mainly be limited to damage inside the unit. For further information, see *Application Note Fuses and Circuit Breakers, MN. 90.Tx.yy*.

The fuses below are suitable for use on a circuit capable of delivering 100,000 Arms (symmetrical), depending on the adjustable frequency drive voltage rating. With the proper fusing the adjustable frequency drive Short Circuit Current Rating (SCCR) is 100,000 Arms.

8.7.1 CE Compliance

200–240 V

Enclosure	Power [kW]	Recommended fuse size	Recommended Max. fuse	Recommended circuit breaker Moeller	Max trip level [A]
A1	0.25–1.5	gG-10	gG-25	PKZM0-16	16
A2	0.25–2.2	gG-10 (0.25–1.5) gG-16 (2.2)	gG-25	PKZM0-25	25
A3	3.0–3.7	gG-16 (3) gG-20 (3.7)	gG-32	PKZM0-25	25
A4	0.25–2.2	gG-10 (0.25–1.5) gG-16 (2.2)	gG-32	PKZM0-25	25
A5	0.25–3.7	gG-10 (0.25–1.5) gG-16 (2.2–3) gG-20 (3.7)	gG-32	PKZM0-25	25
B1	5.5–7.5	gG-25 (5.5) gG-32 (7.5)	gG-80	PKZM4-63	63
B2	11	gG-50	gG-100	NZMB1-A100	100
B3	5.5	gG-25	gG-63	PKZM4-50	50
B4	7.5–15	gG-32 (7.5) gG-50 (11) gG-63 (15)	gG-125	NZMB1-A100	100
C1	15–22	gG-63 (15) gG-80 (18.5) gG-100 (22)	gG-160 (15–18.5) aR-160 (22)	NZMB2-A200	160
C2	30–37	aR-160 (30) aR-200 (37)	aR-200 (30) aR-250 (37)	NZMB2-A250	250
C3	18.5–22	gG-80 (18.5) aR-125 (22)	gG-150 (18.5) aR-160 (22)	NZMB2-A200	150
C4	30–37	aR-160 (30) aR-200 (37)	aR-200 (30) aR-250 (37)	NZMB2-A250	250

Table 8.13 200–240 V, Enclosure Types A, B and C

380–500 V

Enclosure	Power [kW]	Recommended fuse size	Recommended Max. fuse	Recommended circuit breaker Moeller	Max trip level [A]
A1	0.37–1.5	gG-10	gG-25	PKZM0-16	16
A2	0.37–4.0	gG-10 (0.37–3) gG-16 (4)	gG-25	PKZM0-25	25
A3	5.5–7.5	gG-16	gG-32	PKZM0-25	25
A4	0.37–4	gG-10 (0.37–3) gG-16 (4)	gG-32	PKZM0-25	25
A5	0.37–7.5	gG-10 (0.37–3) gG-16 (4–7.5)	gG-32	PKZM0-25	25
B1	11–15	gG-40	gG-80	PKZM4-63	63
B2	18.5–22	gG-50 (18.5) gG-63 (22)	gG-100	NZMB1-A100	100
B3	11–15	gG-40	gG-63	PKZM4-50	50
B4	18.5–30	gG-50 (18.5) gG-63 (22) gG-80 (30)	gG-125	NZMB1-A100	100
C1	30–45	gG-80 (30) gG-100 (37) gG-160 (45)	gG-160	NZMB2-A200	160
C2	55–75	aR-200 (55) aR-250 (75)	aR-250	NZMB2-A250	250
C3	37–45	gG-100 (37) gG-160 (45)	gG-150 (37) gG-160 (45)	NZMB2-A200	150
C4	55–75	aR-200 (55) aR-250 (75)	aR-250	NZMB2-A250	250

Table 8.14 380–500 V, Enclosure Types A, B and C

525–600 V

Enclosure	Power [kW]	Recommended fuse size	Recommended Max. fuse	Recommended circuit breaker Moeller	Max trip level [A]
A2	0.75–4.0	gG-10	gG-25	PKZM0-25	25
A3	5.5–7.5	gG-10 (5.5) gG-16 (7.5)	gG-32	PKZM0-25	25
A5	0.75–7.5	gG-10 (0.75–5.5) gG-16 (7.5)	gG-32	PKZM0-25	25
B1	11–18	gG-25 (11) gG-32 (15) gG-40 (18.5)	gG-80	PKZM4-63	63
B2	22–30	gG-50 (22) gG-63 (30)	gG-100	NZMB1-A100	100
B3	11–15	gG-25 (11) gG-32 (15)	gG-63	PKZM4-50	50
B4	18.5–30	gG-40 (18.5) gG-50 (22) gG-63 (30)	gG-125	NZMB1-A100	100
C1	37–55	gG-63 (37) gG-100 (45) aR-160 (55)	gG-160 (37–45) aR-250 (55)	NZMB2-A200	160
C2	75	aR-200 (75)	aR-250	NZMB2-A250	250
C3	37–45	gG-63 (37) gG-100 (45)	gG-150	NZMB2-A200	150
C4	55–75	aR-160 (55) aR-200 (75)	aR-250	NZMB2-A250	250

Table 8.15 525–600 V, Enclosure Types A, B and C

525–690 V

Enclosure	Power [kW]	Recommended fuse size	Recommended Max. fuse	Recommended circuit breaker Moeller	Max trip level [A]
A3	1.1	gG-6	gG-25	PKZM0-16	16
	1.5	gG-6	gG-25		
	2.2	gG-6	gG-25		
	3	gG-10	gG-25		
	4	gG-10	gG-25		
	5.5	gG-16	gG-25		
B2/B4	7.5	gG-16	gG-25	-	-
	11	gG-25 (11)	gG-63		
	15	gG-32 (15)			
	18	gG-32 (18)			
B4/C2	22	gG-40 (22)		-	-
	30	gG-63 (30)	gG-80 (30)		
C2/C3	37	gG-63 (37)	gG-100 (37)	-	-
	45	gG-80 (45)	gG-125 (45)		
C2	55	gG-100 (55)	gG-160 (55–75)	-	-
	75	gG-125 (75)			

Table 8.16 525–690 V, Enclosure Types A, B and C

8.7.2 UL Compliance

200–240 V

Power [kW]	Recommended max. fuse					
	Bussmann Type RK1 ¹⁾	Bussmann Type J	Bussmann Type T	Bussmann Type CC	Bussmann Type CC	Bussmann Type CC
0.34–5 [0.25–0.37]	KTN-R-05	JKS-05	JJN-05	FNQ-R-5	KTK-R-5	LP-CC-5
0.75–1.5 [0.55–1.1]	KTN-R-10	JKS-10	JJN-10	FNQ-R-10	KTK-R-10	LP-CC-10
1.5	KTN-R-15	JKS-15	JJN-15	FNQ-R-15	KTK-R-15	LP-CC-15
2.2	KTN-R-20	JKS-20	JJN-20	FNQ-R-20	KTK-R-20	LP-CC-20
3.0	KTN-R-25	JKS-25	JJN-25	FNQ-R-25	KTK-R-25	LP-CC-25
3.7	KTN-R-30	JKS-30	JJN-30	FNQ-R-30	KTK-R-30	LP-CC-30
5.5	KTN-R-50	KS-50	JJN-50	-	-	-
7.5	KTN-R-60	JKS-60	JJN-60	-	-	-
11	KTN-R-80	JKS-80	JJN-80	-	-	-
20–25 [15–18.5]	KTN-R-125	JKS-125	JJN-125	-	-	-
22	KTN-R-150	JKS-150	JJN-150	-	-	-
30	KTN-R-200	JKS-200	JJN-200	-	-	-
37	KTN-R-250	JKS-250	JJN-250	-	-	-

Table 8.17 200–240 V, Enclosure Types A, B and C

Power [kW]	Recommended max. fuse							
	SIBA Type RK1	Littelfuse Type RK1	Ferraz-Shawmut Type CC	Ferraz-Shawmut Type RK1 ³⁾	Bussmann Type JFHR2 ²⁾	Littelfuse JFHR2	Ferraz-Shawmut JFHR2 ⁴⁾	Ferraz-Shawmut J
0.25-0.37	5017906-005	KLN-R-05	ATM-R-05	A2K-05-R	FWX-5	-	-	HSJ-6
0.55-1.1	5017906-010	KLN-R-10	ATM-R-10	A2K-10-R	FWX-10	-	-	HSJ-10
1.5	5017906-016	KLN-R-15	ATM-R-15	A2K-15-R	FWX-15	-	-	HSJ-15
2.2	5017906-020	KLN-R-20	ATM-R-20	A2K-20-R	FWX-20	-	-	HSJ-20
3.0	5017906-025	KLN-R-25	ATM-R-25	A2K-25-R	FWX-25	-	-	HSJ-25
3.7	5012406-032	KLN-R-30	ATM-R-30	A2K-30-R	FWX-30	-	-	HSJ-30
5.5	5014006-050	KLN-R-50	-	A2K-50-R	FWX-50	-	-	HSJ-50
7.5	5014006-063	KLN-R-60	-	A2K-60-R	FWX-60	-	-	HSJ-60
11	5014006-080	KLN-R-80	-	A2K-80-R	FWX-80	-	-	HSJ-80
15-18.5	2028220-125	KLN-R-125	-	A2K-125-R	FWX-125	-	-	HSJ-125
22	2028220-150	KLN-R-150	-	A2K-150-R	FWX-150	L25S-150	A25X-150	HSJ-150
30	2028220-200	KLN-R-200	-	A2K-200-R	FWX-200	L25S-200	A25X-200	HSJ-200
37	2028220-250	KLN-R-250	-	A2K-250-R	FWX-250	L25S-250	A25X-250	HSJ-250

Table 8.18 200–240 V, Enclosure Types A, B and C

- 1) KTS fuses from Bussmann may substitute KTN for 240 V adjustable frequency drives.
- 2) FWH fuses from Bussmann may substitute FWX for 240 V adjustable frequency drives.
- 3) A6KR fuses from FERRAZ SHAWMUT may substitute A2KR for 240 V adjustable frequency drives.
- 4) A50X fuses from FERRAZ SHAWMUT may substitute A25X for 240 V adjustable frequency drives.

380–500 V

Power [kW]	Recommended max. fuse					
	Bussmann Type RK1	Bussmann Type J	Bussmann Type T	Bussmann Type CC	Bussmann Type CC	Bussmann Type CC
0.37-1.1	KTS-R-6	JKS-6	JJS-6	FNQ-R-6	KTK-R-6	LP-CC-6
1.5-2.2	KTS-R-10	JKS-10	JJS-10	FNQ-R-10	KTK-R-10	LP-CC-10
3	KTS-R-15	JKS-15	JJS-15	FNQ-R-15	KTK-R-15	LP-CC-15
4	KTS-R-20	JKS-20	JJS-20	FNQ-R-20	KTK-R-20	LP-CC-20
5.5	KTS-R-25	JKS-25	JJS-25	FNQ-R-25	KTK-R-25	LP-CC-25
7.5	KTS-R-30	JKS-30	JJS-30	FNQ-R-30	KTK-R-30	LP-CC-30
11	KTS-R-40	JKS-40	JJS-40	-	-	-
15	KTS-R-50	JKS-50	JJS-50	-	-	-
18	KTS-R-60	JKS-60	JJS-60	-	-	-
22	KTS-R-80	JKS-80	JJS-80	-	-	-
30	KTS-R-100	JKS-100	JJS-100	-	-	-
37	KTS-R-125	JKS-125	JJS-125	-	-	-
45	KTS-R-150	JKS-150	JJS-150	-	-	-
75 [55]	KTS-R-200	JKS-200	JJS-200	-	-	-
75	KTS-R-250	JKS-250	JJS-250	-	-	-

Table 8.19 380–500 V, Enclosure Types A, B and C

Power [kW]	Recommended max. fuse							
	SIBA Type RK1	Littelfuse Type RK1	Ferraz-Shawmut Type CC	Ferraz-Shawmut Type RK1	Bussmann JFHR2	Ferraz-Shawmut J	Ferraz-Shawmut JFHR2 ¹⁾	Littelfuse JFHR2
0.37-1.1	5017906-006	KLS-R-6	ATM-R-6	A6K-6-R	FWH-6	HSJ-6	-	-
1.5-2.2	5017906-010	KLS-R-10	ATM-R-10	A6K-10-R	FWH-10	HSJ-10	-	-
3	5017906-016	KLS-R-15	ATM-R-15	A6K-15-R	FWH-15	HSJ-15	-	-
4	5017906-020	KLS-R-20	ATM-R-20	A6K-20-R	FWH-20	HSJ-20	-	-
5.5	5017906-025	KLS-R-25	ATM-R-25	A6K-25-R	FWH-25	HSJ-25	-	-
7.5	5012406-032	KLS-R-30	ATM-R-30	A6K-30-R	FWH-30	HSJ-30	-	-
11	5014006-040	KLS-R-40	-	A6K-40-R	FWH-40	HSJ-40	-	-
15	5014006-050	KLS-R-50	-	A6K-50-R	FWH-50	HSJ-50	-	-
18	5014006-063	KLS-R-60	-	A6K-60-R	FWH-60	HSJ-60	-	-
22	2028220-100	KLS-R-80	-	A6K-80-R	FWH-80	HSJ-80	-	-
30	2028220-125	KLS-R-100	-	A6K-100-R	FWH-100	HSJ-100	-	-
37	2028220-125	KLS-R-125	-	A6K-125-R	FWH-125	HSJ-125	-	-
45	2028220-160	KLS-R-150	-	A6K-150-R	FWH-150	HSJ-150	-	-
55	2028220-200	KLS-R-200	-	A6K-200-R	FWH-200	HSJ-200	A50-P-225	L50-S-225
75	2028220-250	KLS-R-250	-	A6K-250-R	FWH-250	HSJ-250	A50-P-250	L50-S-250

Table 8.20 380–500 V, Enclosure Types A, B and C

1) Ferraz-Shawmut A50QS fuses may substitute for A50P fuses.

525–600 V

Power [kW]	Recommended max. fuse									
	Bussmann Type RK1	Bussmann Type J	Bussmann Type T	Bussmann Type CC	Bussmann Type CC	Bussmann Type CC	SIBA Type RK1	Littelfuse Type RK1	Ferraz-Shawmut Type RK1	Ferraz-Shawmut J
0.75–1.1	KTS-R-5	JKS-5	JJS-6	FNQ-R-5	KTK-R-5	LP-CC-5	5017906-005	KLS-R-005	A6K-5-R	HSJ-6
1.5-2.2	KTS-R-10	JKS-10	JJS-10	FNQ-R-10	KTK-R-10	LP-CC-10	5017906-010	KLS-R-010	A6K-10-R	HSJ-10
4 [3]	KTS-R15	JKS-15	JJS-15	FNQ-R-15	KTK-R-15	LP-CC-15	5017906-016	KLS-R-015	A6K-15-R	HSJ-15
5 [4]	KTS-R20	JKS-20	JJS-20	FNQ-R-20	KTK-R-20	LP-CC-20	5017906-020	KLS-R-020	A6K-20-R	HSJ-20
7.5 [5.5]	KTS-R-25	JKS-25	JJS-25	FNQ-R-25	KTK-R-25	LP-CC-25	5017906-025	KLS-R-025	A6K-25-R	HSJ-25
10 [7.5]	KTS-R-30	JKS-30	JJS-30	FNQ-R-30	KTK-R-30	LP-CC-30	5017906-030	KLS-R-030	A6K-30-R	HSJ-30
15 [11]	KTS-R-35	JKS-35	JJS-35	-	-	-	5014006-040	KLS-R-035	A6K-35-R	HSJ-35
20 [15]	KTS-R-45	JKS-45	JJS-45	-	-	-	5014006-050	KLS-R-045	A6K-45-R	HSJ-45
25 [18]	KTS-R-50	JKS-50	JJS-50	-	-	-	5014006-050	KLS-R-050	A6K-50-R	HSJ-50
30 [22]	KTS-R-60	JKS-60	JJS-60	-	-	-	5014006-063	KLS-R-060	A6K-60-R	HSJ-60
40 [30]	KTS-R-80	JKS-80	JJS-80	-	-	-	5014006-080	KLS-R-075	A6K-80-R	HSJ-80
50 [37]	KTS-R-100	JKS-100	JJS-100	-	-	-	5014006-100	KLS-R-100	A6K-100-R	HSJ-100
60 [45]	KTS-R-125	JKS-125	JJS-125	-	-	-	2028220-125	KLS-R-125	A6K-125-R	HSJ-125
75 [55]	KTS-R-150	JKS-150	JJS-150	-	-	-	2028220-150	KLS-R-150	A6K-150-R	HSJ-150
100 [75]	KTS-R-175	JKS-175	JJS-175	-	-	-	2028220-200	KLS-R-175	A6K-175-R	HSJ-175

Table 8.21 525–600 V, Enclosure Types A, B and C

525–690 V

Power [kW]	Recommended max. fuse					
	Bussmann Type RK1	Bussmann Type J	Bussmann Type T	Bussmann Type CC	Bussmann Type CC	Bussmann Type CC
1.1	KTS-R-5	JKS-5	JJS-6	FNQ-R-5	KTK-R-5	LP-CC-5
1.5-2.2	KTS-R-10	JKS-10	JJS-10	FNQ-R-10	KTK-R-10	LP-CC-10
4 [3]	KTS-R15	JKS-15	JJS-15	FNQ-R-15	KTK-R-15	LP-CC-15
5 [4]	KTS-R20	JKS-20	JJS-20	FNQ-R-20	KTK-R-20	LP-CC-20
7.5 [5.5]	KTS-R-25	JKS-25	JJS-25	FNQ-R-25	KTK-R-25	LP-CC-25
10 [7.5]	KTS-R-30	JKS-30	JJS-30	FNQ-R-30	KTK-R-30	LP-CC-30
15 [11]	KTS-R-35	JKS-35	JJS-35	-	-	-
20 [15]	KTS-R-45	JKS-45	JJS-45	-	-	-
25 [18]	KTS-R-50	JKS-50	JJS-50	-	-	-
30 [22]	KTS-R-60	JKS-60	JJS-60	-	-	-
40 [30]	KTS-R-80	JKS-80	JJS-80	-	-	-
50 [37]	KTS-R-100	JKS-100	JJS-100	-	-	-
60 [45]	KTS-R-125	JKS-125	JJS-125	-	-	-
75 [55]	KTS-R-150	JKS-150	JJS-150	-	-	-
100 [75]	KTS-R-175	JKS-175	JJS-175	-	-	-

Table 8.22 525–690 V, Enclosure Types A, B and C

Power [kW]	Recommended max. fuse							
	Max. prefuse	Bussmann E52273 RK1/JDDZ	Bussmann E4273 J/JDDZ	Bussmann E4273 T/JDDZ	SIBA E180276 RK1/JDDZ	Littelfuse E81895 RK1/JDDZ	Ferraz-Shawmut E163267/E2137 RK1/JDDZ	Ferraz-Shawmut E2137 J/H SJ
11	30 A	KTS-R-30	JKS-30	JKJS-30	5017906-030	KLS-R-030	A6K-30-R	HST-30
15-18.5	45 A	KTS-R-45	JKS-45	JJS-45	5014006-050	KLS-R-045	A6K-45-R	HST-45
22	60 A	KTS-R-60	JKS-60	JJS-60	5014006-063	KLS-R-060	A6K-60-R	HST-60
30	80 A	KTS-R-80	JKS-80	JJS-80	5014006-080	KLS-R-075	A6K-80-R	HST-80
37	90 A	KTS-R-90	JKS-90	JJS-90	5014006-100	KLS-R-090	A6K-90-R	HST-90
45	100 A	KTS-R-100	JKS-100	JJS-100	5014006-100	KLS-R-100	A6K-100-R	HST-100
55	125 A	KTS-R-125	JKS-125	JJS-125	2028220-125	KLS-150	A6K-125-R	HST-125
75	150 A	KTS-R-150	JKS-150	JJS-150	2028220-150	KLS-175	A6K-150-R	HST-150

Table 8.23 525–690 V, Enclosure Types B and C

8.8 Connection Tightening Torques

Enclosure	Torque [Nm]					
	Line power	Motor	DC connection	Brake	Ground	Relay
A2	1.8	1.8	1.8	1.8	3	0.6
A3	1.8	1.8	1.8	1.8	3	0.6
A4	1.8	1.8	1.8	1.8	3	0.6
A5	1.8	1.8	1.8	1.8	3	0.6
B1	1.8	1.8	1.5	1.5	3	0.6
B2	4.5	4.5	3.7	3.7	3	0.6
B3	1.8	1.8	1.8	1.8	3	0.6
B4	4.5	4.5	4.5	4.5	3	0.6
C1	10	10	10	10	3	0.6
C2	14/24 ¹⁾	14/24 ¹⁾	14	14	3	0.6
C3	10	10	10	10	3	0.6
C4	14/24 ¹⁾	14/24 ¹⁾	14	14	3	0.6

Table 8.24 Tightening Terminals

¹⁾ For different cable dimensions x/y, where $x \leq 95 \text{ mm}^2$ and $y \geq 95 \text{ mm}^2$.

8.9 Power Ratings, Weight and Dimensions

Enclosure Type	A1	A2	A3	A4	A5	B1	B2	B3	B4	C1	C2	C3	C4	D3h
Rated Power (hp [kW])	200-240 V	0.34-2 [0.25-1.5]	4-5 [3-3.7]	0.34-3 [0.25-2.2]	0.34-5 [0.25-3.7]	7.5-10 [5.5-7.5]	15 [11]	7.5-10 [5.5-7.5]	15-20 [11-15]	20-30 [15-22]	40-50 [30-37]	25-30 [18.5-22]	40-50 [30-37]	-
	380-480/500 V	0.5-2 [0.37-1.5]	7.5-10 [5.5-7.5]	5-5 [0.37-4]	0.5-10 [0.37-7.5]	15-20 [11-15]	25-30 [18.5-22]	15-20 [11-15]	25-40 [18.5-30]	40-60 [30-45]	75-100 [55-75]	50-60 [37-45]	75-100 [55-75]	-
525-600 V			1-10 [0.75-7.5]		1-10 [0.75-7.5]	15-20 [11-15]	25-30 [18.5-22]	15-20 [11-15]	25-40 [18.5-30]	40-60 [30-45]	75-125 [55-90]	50-60 [37-45]	75-125 [55-90]	-
	525-690 V		1.5-10 [1.1-7.5]				15-30 [11-22]		15-40 [11-30]		40-100 [30-75]	50-60 [37-45]	50-60 [37-45]	75-100 [55-75]
IP	20	20	20	20	20	20	20	20	20	20	20	20	20	20
NEMA	Chas sis	Chas sis	Chas sis	Type 12/4X	Type 12/4X	Type 66 1/12/4X	Type 66 1/12/4X	Chas sis	Chas sis	Type 1/12/4X	Type 1/12/4X	Chas sis	Chas sis	Chas sis
Height (in [mm])														
Height of backplate	8 [200]	10.60 [268]	10.60 [268]	14.76 [375]	14.76 [375]	18.90 [480]	25.59 [650]	15.71 [399]	20.47 [520]	26.77 [680]	30.32 [770]	21.65 [550]	25.98 [660]	35.80 [909]
Height with decoupling plate for serial communication bus cables	12.44 [316]	14.72 [374]	14.72 [374]	-	-	-	-	16.54 [420]	23.43 [595]			24.80 [630]	31.5 [800]	
Distance between mounting holes	7.48 [190]	10.12 [257]	10.12 [257]	13.80 [350]	13.80 [350]	17.87 [454]	24.57 [624]	14.96 [380]	19.50 [495]	25.51 [648]	29.1 [739]	20.51 [521]	24.84 [631]	
Width (in [mm])														
Width of backplate	2.95 [75]	3.54 [90]	5.12 [130]	7.87 [200]	9.53 [242]	9.53 [242]	9.53 [242]	6.5 [165]	9.06 [230]	12.13 [308]	15.57 [370]	12.13 [308]	15.57 [370]	35.0 [250]
Width of backplate with one C option		5.12 [130]	6.69 [170]		9.53 [242]	9.53 [242]	9.53 [242]	8.07 [205]	9.06 [230]	12.13 [308]	15.57 [370]	12.13 [308]	15.57 [370]	
Width of backplate with two C options		5.91 [150]	7.48 [190]		9.53 [242]	9.53 [242]	9.53 [242]	8.86 [225]	9.06 [230]	12.13 [308]	15.57 [370]	12.13 [308]	15.57 [370]	
Distance between mounting holes	2.36 [60]	2.76 [70]	4.33 [110]	6.73 [171]	8.47 [215]	8.27 [210]	8.27 [210]	5.51 [140]	7.87 [200]	10.71 [272]	13.15 [334]	10.63 [270]	12.99 [330]	





Enclosure Type	A1	A2	A3	A4	A5	B1	B2	B3	B4	C1	C2	C3	C4	D3h
Depth (in [mm])														
Depth without option A/B	18.15 [207]	8.07 [205]	18.15 [207]	8.07 [205]	18.15 [207]	8.07 [205]	18.15 [207]	8.07 [205]	18.15 [207]	18.15 [207]	18.15 [207]	18.15 [207]	18.15 [207]	18.15 [207]
With option A/B	8.74 [222]	8.66 [220]	8.74 [222]	8.66 [220]	8.74 [222]	8.66 [220]	8.74 [222]	8.66 [220]	8.74 [222]	8.66 [220]	8.74 [222]	8.66 [220]	8.74 [222]	8.66 [220]
Screw holes (in [mm])														
c	0.24 [6.0]	0.32 [8.0]	0.32 [8.0]	0.32 [8.0]	0.33 [8.25]	0.47 [12]	0.47 [12]	0.32 [8]		0.49 [12.5]	0.49 [12.5]			
d	ø0.32 [ø8]	ø0.43 [ø11]	ø0.43 [ø11]	ø0.43 [ø11]	ø0.47 [ø12]	ø0.75 [ø19]	ø0.75 [ø19]	0.47 [12]		ø0.75 [ø19]	ø0.75 [ø19]			
e	ø0.2 [ø5.5]	ø0.22 [ø5.5]	ø0.22 [ø5.5]	ø0.22 [ø5.5]	ø0.26 [ø6.5]	ø0.35 [ø9]	ø0.35 [ø9]	0.28 [6.8]	0.34 [8.5]	ø0.35 [ø9]	ø0.35 [ø9]	0.34 [8.5]	0.34 [8.5]	
f	0.2 [5]	0.35 [9]	0.26 [6.5]	0.24 [6]	0.35 [9]	0.35 [9]	0.35 [9]	0.31 [7.9]	0.60 [15]	0.39 [9.8]	0.39 [9.8]	0.68 [17]	0.68 [17]	
Max weight lbs [kg]	6 [2.7]	10.8 [4.9]	14.6 [6.6]	21.5 [9.7]	30/31.5 [13.5/14.2]	51 [23]	60 [27]	26.5 [12]	52 [23.5]	100 [45]	144 [65]	78 [35]	111 [50]	137 [62]
Front cover tightening torque [Nm]														
Plastic cover (low IP)	Click	Click	Click	-	-	Click	Click	Click	Click	Click	Click	Click	Click	Click
Metal cover (IP55/66)	-	-	-	1.5	1.5	2.2	2.2	-	-	2.2	2.2	2.0	2.0	2.0

Table 8.25 Power Ratings, Weight and Dimensions

9 Appendix

9.1 Symbols, Abbreviations and Conventions

AC	Alternating Current
AEO	Automatic Energy Optimization
AWG	American Wire Gauge
AMA	Automatic Motor Adaptation
°C	Degrees Celsius
DC	Direct Current
EMC	Electro Magnetic Compatibility
ETR	Electronic Thermal Relay
FC	Adjustable Frequency Drive
LCP	Local Control Panel
MCT	Motion Control Tool
IP	Ingress Protection
$I_{M,N}$	Nominal Motor Current
$f_{M,N}$	Nominal Motor Frequency
$P_{M,N}$	Nominal Motor Power
$U_{M,N}$	Nominal Motor Voltage
PM Motor	Permanent Magnet Motor
PELV	Protective Extra Low Voltage
PCB	Printed Circuit Board
I_{LIM}	Current Limit
I_{INV}	Rated Inverter Output Current
RPM	Revolutions Per Minute
Regen	Regenerative Terminals
n_s	Synchronous Motor Speed
T_{LIM}	Torque Limit
$I_{VLT,MAX}$	The Maximum Output Current
$I_{VLT,N}$	The Rated Output Current Supplied by the Adjustable Frequency Drive

Table 9.1 Symbols and Abbreviations

Conventions

Numbered lists indicate procedures.

Bullet lists indicate other information and description of figures.

Italicized text indicates

- cross reference
- link
- parameter name

9.2 Parameter Menu Structure

0-0*	0-01	0-02	0-03	0-04	0-09	0-1*	0-10	0-11	0-12	0-13	0-14	0-15	0-2*	0-20	0-21	0-22	0-23	0-24	0-25	0-3*	0-30	0-31	0-32	0-37	0-38	0-39	0-4*	0-40	0-41	0-42	0-43	0-44	0-45	0-50	0-51	0-60	0-61	0-65	0-66	0-67	0-68	0-69	1-0*	1-00	1-01	1-02	1-03	1-04	1-05	1-06	1-07	1-1*	1-10																																																																																																																			
Operation/Display	Basic Settings	Language	Motor Speed Unit	Regional Settings	Operating State at Power-up (Hand)	Performance Monitor	Set-up Operations	Active Set-up	Edit Set-up	This Set-up Linked to	Readout: Linked Set-ups	Readout: Edit Set-ups / Channel	Readout: actual setup	LCP Display	Display Line 1.1 Small	Display Line 1.2 Small	Display Line 1.3 Small	Display Line 2 Large	Display Line 3 Large	My Personal Menu	LCP Cust. Readout	Unit for User-defined Readout	Min Value of User-defined Readout	Max Value of User-defined Readout	Display Text 1	Display Text 2	Display Text 3	LCP Keypad	[Hand on] Key on LCP	[Off] Key on LCP	[Auto on] Key on LCP	[Reset] Key on LCP	[Off/Reset] Key on LCP	[Drive Bypass] Key on LCP	Copy/Save	LCP Copy	Set-up Copy	Password	Main Menu Password	Access to Main Menu w/o Password	Quick Menu Password	Access to Quick Menu w/o Password	Bus Password Access	Safety Parameters Password	Password Protection of Safety Parameters	Load and Motor	General Settings	Configuration Mode	Motor Control Principle	Flux Motor Feedback Source	Torque Characteristics	Overload Mode	Local Mode Configuration	Clockwise Direction	Motor Angle Offset Adjust	Special Settings	Motor Construction																																																																																																															
1-11	1-14	1-15	1-16	1-17	1-18	1-2*	1-20	1-21	1-22	1-23	1-24	1-25	1-26	1-29	1-3*	1-30	1-31	1-33	1-34	1-35	1-36	1-37	1-38	1-39	1-40	1-41	1-44	1-45	1-46	1-47	1-48	1-5*	1-50	1-51	1-52	1-53	1-55	1-56	1-58	1-59	1-6*	1-60	1-61	1-62	1-63	1-64	1-65	1-66	1-67	1-68	1-69	1-7*	1-70	1-71	1-72	1-73																																																																																																																
Motor Model	Damping Gain	Low Speed Filter Time Const.	High Speed Filter Time Const.	Voltage filter time const.	Min. Current at No Load	Motor Data	Motor Power [kW]	Motor Power [HP]	Motor Voltage	Motor Frequency	Motor Current	Motor Nominal Speed	Motor Cont. Rated Torque	Automatic Motor Adaptation (AMA)	Addl. Motor Data	Stator Resistance (Rs)	Rotor Resistance (Rr)	Stator Leakage Reactance (X1)	Rotor Leakage Reactance (X2)	Main Reactance (Xh)	Iron Loss Resistance (Rfe)	d-axis Inductance (Ld)	q-axis Inductance (Lq)	Motor Poles	Back EMF at 1000 RPM	Motor Angle Offset	d-axis Inductance Sat. (LdSat)	q-axis Inductance Sat. (LqSat)	Position Detection Gain	Torque Calibration	Inductance Sat. Point	Load-Indep. Setting	Motor Magnetization at Zero Speed	Min Speed Normal Magnetizing [RPM]	Min Speed Normal Magnetizing [Hz]	Model Shift Frequency	Voltage reduction in fieldweakening	U/f Characteristic - U	U/f Characteristic - F	Flystart Test Pulses Current	Flystart Test Pulses Frequency	Load-Depend. Settng.	Low Speed Load Compensation	High Speed Load Compensation	Slip Compensation	Slip Compensation Time Constant	Resonance Damping	Resonance Damping Time Constant	Min. Current at Low Speed	Load Type	Minimum Inertia	Maximum Inertia	Start Adjustments	PM Start Mode	Start Delay	Flying Start																																																																																																																
1-74	1-75	1-76	1-8*	1-80	1-81	1-82	1-83	1-84	1-85	1-9*	1-90	1-91	1-93	1-94	1-95	1-96	1-97	1-98	1-99	2-*	2-0*	2-00	2-01	2-02	2-03	2-04	2-05	2-06	2-07	2-1*	2-10	2-11	2-12	2-13	2-15	2-16	2-17	2-18	2-19	2-2*	2-20	2-21	2-22	2-23	2-24	2-25	2-26	2-27	2-28	2-29	2-30	2-31	2-32	2-33	3-*	3-0*	3-01	3-02	3-03	3-04	3-1*	3-10	3-11	3-12	3-13	3-14	3-15	3-16	3-17	3-18	3-19	3-4*	3-40	3-41	3-42	3-43	3-44	3-45	3-46	3-47	3-48	3-5*	3-50	3-51	3-52	3-53	3-54	3-55	3-56	3-57	3-58	3-6*	3-60	3-61	3-62	3-63	3-64	3-65	3-66	3-67	3-68	3-7*	3-70	3-71	3-72	3-73	3-74	3-75	3-76	3-77	3-78	3-8*	3-80	3-81	3-82	3-83	3-84	3-9*	3-90																																																	
Start Speed [RPM]	Start Speed [Hz]	Start Current	Stop Adjustments	Function at Stop	Min. Speed for Function at Stop [RPM]	Min Speed for Function at Stop [Hz]	Precise Stop Function	Precise Stop Counter Value	Precise Stop Speed Compensation	Motor Temperature	Motor Thermal Protection	Motor External Fan	Thermistor Resource	ATEX ETR cut.lim. speed reduction	KTY Sensor Type	KTY Threshold level	ATEX ETR interpol. points freq.	ATEX ETR interpol. points current	DC Brake	DC Hold Current	DC Brake Current	DC Braking Time	DC Brake Cut-in Speed [RPM]	DC Brake Cut-in Speed [Hz]	Maximum Reference	Parking Time	Brake Energy Funct.	Brake Function	Brake Resistor (ohm)	Brake Power Limit (kW)	Brake Power Monitoring	Brake Check	AC Brake Max. Current	Over-voltage Control	Brake Check Condition	Over-voltage Gain	Mechanical Brake	Release Brake Current	Activate Brake Speed [RPM]	Activate Brake Speed [Hz]	Activate Brake Delay	Stop Delay	Brake Release Time	Torque Ref	Torque Ramp Up Time	Gain Boost Factor	Torque Ramp Down Time	Adv. Mech Brake	Position P Start Proportional Gain	Speed PID Start Proportional Gain	Speed PID Start Integral Time	Speed PID Start Lowpass Filter Time	Reference / Ramps	Start Speed [RPM]	Reference Range	Reference/Feedback Unit	Minimum Reference	Maximum Reference	Reference Function	Preset Reference	Jog Speed [Hz]	Catch up/slow-down value	Reference Site	Preset Relative Reference	Reference Resource 1	Reference Resource 2	Reference Resource 3	Relative Scaling Reference Resource	Jog Speed [RPM]	Ramp 1	Ramp 1 Type	Ramp 1 Ramp-up Time	Ramp 1 Ramp-down Time	Ramp 1 S-ramp Ratio at Accel. Start	Ramp 1 S-ramp Ratio at Accel. End	Ramp 1 S-ramp Ratio at Decel. Start	Ramp 1 S-ramp Ratio at Decel. End	Ramp 2	Ramp 2 Type	Ramp 2 Ramp-up Time	Ramp 2 Ramp-down Time	Ramp 2 S-ramp Ratio at Accel. Start	Ramp 2 S-ramp Ratio at Accel. End	Ramp 2 S-ramp Ratio at Decel. Start	Ramp 2 S-ramp Ratio at Decel. End	Ramp 3	Ramp 3 Type	Ramp 3 Ramp-up Time	Ramp 3 Ramp-down Time	Ramp 3 S-ramp Ratio at Accel. Start	Ramp 3 S-ramp Ratio at Accel. End	Ramp 3 S-ramp Ratio at Decel. Start	Ramp 3 S-ramp Ratio at Decel. End	Ramp 4	Ramp 4 Type	Ramp 4 Ramp-up Time	Ramp 4 Ramp-down Time	Ramp 4 S-ramp Ratio at Accel. Start	Ramp 4 S-ramp Ratio at Accel. End	Ramp 4 S-ramp Ratio at Decel. Start	Ramp 4 S-ramp Ratio at Decel. End	Other Ramps	Jog Ramp Time	Quick Stop Ramp Time	Quick Stop Ramp Type	Quick Stop S-ramp Ratio at Decel. Start	Quick Stop S-ramp Ratio at Decel. End	Quick Stop S-ramp Ratio at Decel. End	Digital Pot. meter	Step Size	Ramp Time	Power Restore	Maximum Limit	Minimum Limit	Ramp Delay	Motor Limits / Warnings	Motor Limits	Motor Speed Direction	Motor Speed Low Limit [RPM]	Motor Speed Low Limit [Hz]	Motor Speed High Limit [RPM]	Motor Speed High Limit [Hz]	Torque Limit Motor Mode	Torque Limit Generator Mode	Current Limit	Max Output Frequency	Limit Factors	Torque Limit Factor Source	Speed Limit Factor Source	Motor Speed Mon.	Motor Feedback Loss Function	Motor Feedback Speed Error	Motor Feedback Loss Timeout	Tracking Error Function	Tracking Error	Tracking Error Timeout	Tracking Error Ramping	Tracking Error Ramping Timeout	Tracking Error After Ramping Timeout	Adj. Warnings	Warning Current Low	Warning Current High	Warning Speed Low	Warning Speed High	Warning Reference Low	Warning Reference High	Warning Feedback Low	Warning Feedback High	Missing Motor Phase Function	Speed Bypass	Bypass Speed From [RPM]	Bypass Speed From [Hz]	Bypass Speed to [RPM]	Bypass Speed to [Hz]	Digital In/Out	Digital I/O mode	Digital I/O Mode	Terminal 27 Mode	Terminal 29 Mode	Digital Inputs	Terminal 18 Digital Input	Terminal 19 Digital Input	Terminal 27 Digital Input	Terminal 29 Digital Input	Terminal 32 Digital Input	Terminal 33 Digital Input	Terminal X30/2 Digital Input	Terminal X30/3 Digital Input

5-18	Terminal X30/4 Digital Input	6-15	Terminal 53 High Ref./Feedb. Value	7-08	Speed PID Feed Forward Factor	8-36	Max Response Delay	9-84	Defined Parameters (5)
5-19	Terminal 37 Safe Stop	6-16	Terminal 53 Filter Time Constant	7-09	Speed PID Error Correction w/ Ramp	8-37	Max Inter-Char Delay	9-85	Defined Parameters (6)
5-20	Terminal X46/1 Digital Input	6-2*	Analog Input 2	7-1*	Torque PI Ctrl.	8-4*	FC MC protocol set	9-90	Changed Parameters (1)
5-21	Terminal X46/3 Digital Input	6-20	Terminal 54 Low Voltage	7-12	Torque PI Proportional Gain	8-40	Telegram selection	9-91	Changed Parameters (2)
5-22	Terminal X46/5 Digital Input	6-21	Terminal 54 High Voltage	7-13	Torque PI Integration Time	8-41	Parameters for Signals	9-92	Changed Parameters (3)
5-23	Terminal X46/7 Digital Input	6-22	Terminal 54 Low Current	7-19	Current Controller Rise Time	8-42	PCD Write Configuration	9-93	Changed Parameters (4)
5-24	Terminal X46/9 Digital Input	6-23	Terminal 54 High Current	7-2*	Process Ctrl. Feedb	8-43	PCD Read Configuration	9-94	Changed parameters (5)
5-25	Terminal X46/11 Digital Input	6-24	Terminal 54 Low Ref./Feedb. Value	7-20	Process CL Feedback 1 Resource	8-45	BTM Transaction Command	9-99	Profibus Revision Counter
5-26	Terminal X46/13 Digital Input	6-25	Terminal 54 High Ref./Feedb. Value	7-22	Process CL Feedback 2 Resource	8-46	BTM Transaction Status	10-3*	CAN Fieldbus
5-3*	Digital Outputs	6-26	Terminal 54 Filter Time Constant	7-3*	Process PID Ctrl.	8-47	BTM Timeout	10-0*	Common Settings
5-30	Terminal 27 Digital Output	6-3*	Analog Input 53	7-30	Process PID Normal/Inverse Control	8-48	BTM Maximum Errors	10-00	CAN Protocol
5-31	Terminal 29 Digital Output	6-30	Terminal X30/11 Low Voltage	7-31	Process PID Anti Windup	8-49	BTM Error Log	10-01	Baud Rate Select
5-32	Term X30/6 Digi Out (MCB 101)	6-31	Terminal X30/11 High Voltage	7-32	Process PID Controller Start Value	8-5*	Digital/Bus	10-02	MAC ID
5-33	Term X30/7 Digi Out (MCB 101)	6-34	Term. X30/11 Low Ref./Feedb. Value	7-33	Process PID Proportional Gain	8-50	Coasting Select	10-05	Readout Transmit Error Counter
5-4*	Relays	6-35	Term. X30/11 High Ref./Feedb. Value	7-34	Process PID Integral Time	8-51	Quick Stop Select	10-06	Readout Receive Error Counter
5-40	Function Relay	6-36	Term. X30/11 Filter Time Constant	7-35	Process PID Differentiation Time	8-52	DC Brake Select	10-07	Readout Bus Off Counter
5-41	On Delay, Relay	6-4*	Analog Input 4	7-36	Process PID Differentiation Gain Limit	8-53	Start Select	10-1*	DeviceNet
5-42	Off Delay, Relay	6-40	Terminal X30/12 Low Voltage	7-38	Process PID Feed Forward Factor	8-54	Reverse Select	10-10	Process Data Type Selection
5-50	Term. 29 Low Frequency	6-41	Terminal X30/12 High Voltage	7-39	On Reference Bandwidth	8-55	Set-up Select	10-11	Process Data Config Write
5-51	Term. 29 High Frequency	6-44	Term. X30/12 Low Ref./Feedb. Value	7-4*	Adv. Process PID 1	8-56	Preset Reference Select	10-12	Process Data Config Read
5-52	Term. 29 Low Ref./Feedb. Value	6-45	Term. X30/12 High Ref./Feedb. Value	7-41	Process PID i-part Reset	8-57	Profidrive OFF2 Select	10-13	Warning Parameter
5-53	Term. 29 High Ref./Feedb. Value	6-46	Term. X30/12 Filter Time Constant	7-40	Process PID Output Neg. Clamp	8-58	Profidrive OFF3 Select	10-14	Net Reference
5-54	Pulse Filter Time Constant #29	6-5*	Analog Output 1	7-42	Process PID Output Pos. Clamp	8-8*	AFD Port Diagnostics	10-15	Net Control
5-55	Term. 33 Low Frequency	6-50	Terminal 42 Output	7-43	Process PID Gain Scale at Min. Ref.	8-80	Bus Message Count	10-2*	COS Filters
5-56	Term. 33 High Frequency	6-51	Terminal 42 Output Min Scale	7-44	Process PID Gain Scale at Max. Ref.	8-81	Bus Error Count	10-20	COS Filter 1
5-57	Term. 33 Low Ref./Feedb. Value	6-52	Terminal 42 Output Max Scale	7-45	Process PID Feed Fwd Resource	8-82	Slave Messages Rcvd	10-21	COS Filter 2
5-58	Term. 33 High Ref./Feedb. Value	6-53	Term. 42 Output Bus Ctrl	7-46	Process PID Feed Fwd Normal/ Invt. Ctrl.	8-83	Slave Error Count	10-22	COS Filter 3
5-59	Pulse Filter Time Constant #33	6-55	Analog Output Filter	7-48	PCD Feed Forward	8-90	Bus Jog 1 Speed	10-23	COS Filter 4
5-60	Terminal 27 Pulse Output Variable	6-6*	Analog Output 2	7-49	Process PID Output Normal/ Inv. Ctrl.	8-90	Bus Jog 1 Speed	10-3*	Parameter Access
5-62	Pulse Output Max Freq #27	6-61	Terminal X30/8 Output	7-5*	Adv. Process PID 2	9-*	PROFIdrive	10-31	Store Data Values
5-63	Terminal 29 Pulse Output Variable	6-62	Terminal X30/8 Min. Scale	7-50	Process PID Extended PID	9-00	Setpoint	10-32	Devenet Revision
5-65	Pulse Output Max Freq #29	6-63	Terminal X30/8 Max. Scale	7-51	Process PID Feed Fwd Gain	9-07	Actual Value	10-33	Store Always
5-66	Terminal X30/6 Pulse Output Variable	6-64	Terminal X30/8 Bus Control	7-52	Process PID Feed Fwd Ramp-up	9-15	PCD Write Configuration	10-34	DeviceNet Product Code
5-68	Pulse Output Max Freq #X30/6	6-7*	Analog Output 3	7-53	Process PID Feed Fwd Ramp-down	9-16	PCD Read Configuration	10-39	Devenet F Parameters
5-70	Term 32/33 Pulses Per Revolution	6-70	Terminal X45/1 Output	7-56	Process PID Fb. Filter Time	9-18	Node Address	10-5*	CANopen
5-71	Term 32/33 Encoder Direction	6-71	Terminal X45/1 Min. Scale	8-*	Comm. and Options	9-19	Drive Unit System Number	10-50	Process Data Config Write.
5-8*	I/O Options	6-72	Terminal X45/1 Max. Scale	8-0*	General Settings	9-22	Telegram Selection	10-51	Process Data Config Read.
5-80	AHF Cap Reconnect Delay	6-73	Terminal X45/1 Bus Control	8-01	Control Site	9-27	Parameter Edit	12-0*	IP Settings
5-90	Digital & Relay Bus Control	6-74	Terminal X45/1 Output Timeout	8-02	Control Word Source	9-28	Process Control	12-00	IP Address Assignment
5-93	Pulse Out #27 Bus Control	6-8*	Analog Output 4	8-03	Control Word Timeout Function	9-44	Fault Message Counter	12-01	IP Address
5-95	Pulse Out #29 Bus Control	6-80	Terminal X45/3 Output	8-04	Control Word Timeout Function	9-45	Fault Code	12-02	Subnet Mask
5-96	Pulse Out #29 Timeout Preset	6-81	Terminal X45/3 Min. Scale	8-05	End-of-Timeout Function	9-47	Fault Number	12-03	Default Gateway
5-97	Pulse Out #29 Timeout Preset	6-82	Terminal X45/3 Max. Scale	8-06	Reset Control Word Timeout	9-52	Fault Situation Counter	12-04	DHCP Server
5-98	Pulse Out #X30/6 Bus Control	6-83	Terminal X45/3 Bus Control	8-07	Diagnosis Trigger	9-53	Profibus Warning Word	12-05	Lease Expires
6-*	Analog In/Out	6-84	Terminal X45/3 Output Timeout	8-08	Readout Filtering	9-63	Actual Baud Rate	12-06	Name Servers
6-00	Live Zero Timeout Time	7-0*	Speed PID Ctrl.	8-1*	Ctrl. Word Settings	9-64	Device Identification	12-07	Domain Name
6-01	Live Zero Timeout Function	7-00	Speed PID Feedback Source	8-10	Control Word Profile	9-65	Profile Number	12-08	Host Name
6-1*	Analog Input 1	7-02	Speed PID Proportional Gain	8-13	Configurable Status Word STW	9-67	Control Word 1	12-09	Physical Address
6-10	Terminal 53 Low Voltage	7-03	Speed PID Integral Time	8-14	Configurable Control Word CTW	9-68	Status Word 1	12-1*	Eth link par
6-11	Terminal 53 High Voltage	7-04	Speed PID Differentiation Time	8-19	Product Code	9-70	Edit-Set-up	12-10	Link Status
6-12	Terminal 53 Low Current	7-05	Speed PID Diff. Gain Limit	8-3*	FC Port Settings	9-71	Profibus Save Data Values	12-11	Link Duration
6-13	Terminal 53 High Current	7-06	Speed PID Lowpass Filter Time	8-31	Protocol	9-72	Profibus DriveReset	12-12	Auto Negotiation
6-14	Terminal 53 Low Ref./Feedb. Value	7-07	Speed PID Feedback Gear Ratio	8-32	Address	9-75	DO Identification	12-13	Link Speed
				8-33	FC Port Baud Rate	9-80	Defined Parameters (1)	12-14	Link Duplex
				8-34	Parity / Stop Bits	9-81	Defined Parameters (2)	12-2*	Process Data
				8-35	Estimated cycle time	9-82	Defined Parameters (3)	12-20	Control Instance
					Minimum Response Delay	9-83	Defined Parameters (4)	12-21	Process Data Config Write

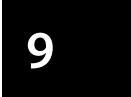

12-22	Process Data Config Read	14-74	Leg. Ext. Status Word	15-77	Slot C1/E1 Option SW Version	16-60	Digital Input
12-23	Process Data Config Write Size	14-80	Options	15-8*	Operating Data II	16-61	Terminal 53 Switch Setting
12-24	Process Data Config Read Size	14-80	Option Supplied by External 24VDC	15-80	Fan Running Hours	16-62	Analog Input 53
12-27	Master Address	14-88	Option Data Storage	15-81	Preset Fan Running Hours	16-63	Terminal 54 Switch Setting
12-28	Store Data Values	14-89	Option Detection	15-89	Configuration Change Counter	16-64	Analog Input 54
12-29	Store Always	14-9*	Fault Settings	15-9*	Parameter Info	16-65	Analog Output 42 [mA]
12-3*	EtherNet/IP	14-90	Fault Level	15-92	Defined Parameters	16-66	Digital Output [bin]
12-30	Warning Parameter	15**	Drive Information	15-93	Modified Parameters	16-67	Freq. Input #29 [Hz]
12-31	Net Reference	15-0*	Operating Data	15-98	Drive Identification	16-68	Freq. Input #33 [Hz]
12-32	Net Control	15-00	Operating hours	15-99	Parameter Metadata	16-69	Pulse Output #27 [Hz]
12-33	CIP Revision	15-01	Running Hours	16**	Data Readouts	16-70	Pulse Output #29 [Hz]
12-34	CIP Product Code	15-02	kWh Counter	16-0*	General Status	16-71	Relay Output [bin]
12-37	COS Inhibit Timer	15-03	Power-ups	16-00	Control Word	16-72	Counter A
12-38	COS Filter	15-04	Over Temps	16-01	Reference [Unit]	16-73	Counter B
12-40	Status Parameter	15-05	Over Volts	16-02	Reference %	16-74	Prec. Stop Counter
12-5*	EtherCAT	15-06	Reset kWh Counter	16-03	Status Word	16-75	Analog In X30/11
12-50	Configured Station Alias	15-07	Reset Running Hours Counter	16-05	Main Actual Value [%]	16-76	Analog In X30/12
12-51	Configured Station Address	15-1*	Data Log Settings	16-09	Custom Readout	16-77	Analog Out X30/8 [mA]
12-59	EtherCAT Status	15-10	Logging Source	16-10	Motor Status	16-78	Analog Out X45/1 [mA]
12-6*	Ethernet PowerLink	15-11	Logging Interval	16-11	Power [kW]	16-79	Analog Out X45/3 [mA]
12-60	Node ID	15-12	Trigger Event	16-12	Power [hp]	16-8*	Fieldbus & FC Port
12-63	Basic Ethernet Timeout	15-13	Logging Mode	16-13	Frequency	16-80	Fieldbus CTW 1
12-66	Threshold	15-14	Samples Before Trigger	16-14	Motor current	16-82	Fieldbus REF 1
12-67	Threshold Counters	15-2*	Historic Log	16-15	Frequency [%]	16-84	Comm. Option Status
12-68	Cumulative Counters	15-20	Historic Log: Event	16-16	Torque [Nm]	16-85	FC Port CTW 1
12-69	Ethernet PowerLink Status	15-21	Historic Log: Value	16-17	Speed [RPM]	16-86	FC Port REF 1
12-8*	Oth. Ethernet services	15-22	Historic Log: Time	16-18	Motor Thermal	16-87	Bus Readout Alarm/Warning
12-80	FIP Server	15-3*	Fault Log	16-19	KTY sensor temperature	16-9*	Diagnosis Readouts
12-81	HTTP Server	15-30	Fault Log: Error Code	16-20	Motor Angle	16-90	Alarm Word
12-82	SMTP Service	15-31	Fault Log: Value	16-21	Torque [%] High Res.	16-91	Alarm Word 2
12-89	Transparent Socket Channel Port	15-32	Fault Log: Time	16-22	Torque [%]	16-92	Warning Word
12-90	Cable Diagnostic	15-4*	Drive Identification	16-23	Motor Shaft Power [kW]	16-93	Warning Word 2
12-91	Auto Cross Over	15-40	FC Type	16-24	Calibrated Stator Resistance	16-94	Ext. Status Word
12-92	IGMP Snooping	15-42	Voltage	16-25	Torque [Nm] High	17**	Feedback Option
12-93	Cable Error Length	15-43	Software Version	16-3*	Drive Status	17-1*	Inc. Enc. Interface
12-94	Broadcast Storm Protection	15-44	Ordered Typecode String	16-30	DC Link Voltage	17-10	Signal Type
12-95	Broadcast Storm Filter	15-45	Actual Typecode String	16-32	Brake Energy /s	17-11	Resolution (PPR)
12-96	Port Config	15-46	Adj Freq Dr Ordering No.	16-33	Brake Energy /2 min	17-2*	Abs. Enc. Interface
12-98	Interface Counters	15-47	Power Card Ordering No.	16-34	Heatsink Temp.	17-20	Protocol Selection
12-99	Media Counters	15-48	LCP ID Num.	16-35	Inverter Thermal	17-21	Resolution (Positions/Rev)
13**	Smart Logic	15-49	SW ID Control Card	16-36	Inv. Nom. Current	17-24	SSI Data Length
13-0*	SLC Settings	15-50	SW ID Power Card	16-37	Inv. Max. Current	17-25	Clock Rate
13-00	SL Controller Mode	15-51	Adj Freq Dr. Serial No.	16-38	SL Controller State	17-26	SSI Data Format
13-01	Start Event	15-53	Power Card Serial Number	16-39	Control Card Temp.	17-34	HIPERFACE Baud rate
13-02	Stop Event	15-58	Smart Setup Filename	16-40	Logging Buffer Full	17-5*	Resolver Interface
13-03	Reset SLC	15-59	CSV Filename	16-41	LCP Bottom Statusline	17-50	Poles
13-1*	Comparators	15-6*	Option Ident	16-45	Motor Phase U Current	17-51	Input Voltage
13-10	Comparator Operand	15-60	Option Mounted	16-46	Motor Phase V Current	17-52	Input Frequency
13-11	Comparator Operator	15-61	Option SW Version	16-47	Motor Phase W Current	17-53	Transformation Ratio
13-12	Comparator Value	15-62	Option Ordering No	16-48	Speed Ref. After Ramp [RPM]	17-56	Encoder Sim. Resolution
13-1*	RS Flip Flops	15-63	Option Serial No	16-49	Current Fault Source	17-59	Resolver Interface
13-15	RS-FF Operand S	15-70	Option in Slot A	16-5*	Ref. & Feedb.	17-6*	Monitoring and App.
13-16	RS-FF Operand R	15-71	Slot A Option SW Version	16-50	External Reference	17-60	Feedback Direction
		15-72	Option in Slot B	16-51	Pulse Reference	17-61	Feedback Signal Monitoring
		15-73	Slot B Option SW Version	16-52	Feedback [Unit]	18**	Data Readouts 2
		15-74	Option in Slot CO	16-53	Digi Pot Reference	18-3*	Analog Readouts
		15-75	Slot CO/E0 Option SW Version	16-57	Feedback [RPM]	18-36	Analog Input X48/2 [mA]
		15-76	Option in Slot C1	16-6*	Inputs & Outputs	18-37	Temp. Input X48/4
						18-38	Temp. Input X48/7

18-39	Temp. Input X48/10	33-12	Position Offset for Synchronization	33-84	Behavior afterEsc.	35-02	Term. X48/7 Temp. Unit
18-6*	Inputs & Outputs 2	33-13	Accuracy Window for Position Sync	33-85	MCO Supplied by External 24VDC	35-03	Term. X48/7 Input Type
18-60	Digital Input 2	33-14	Relative Slave Velocity Limit	33-86	Terminal at alarm	35-04	Term. X48/10 Temp. Unit
18-9*	PID Readouts	33-15	Marker Number for Master	33-87	Terminal state at alarm	35-05	Term. X48/10 Input Type
18-90	Process PID Error	33-16	Marker Number for Slave	33-88	Status word at alarm	35-06	Temperature Sensor Alarm Function
18-91	Process PID Output	33-17	Master Marker Distance	33-9*	MCO Port Settings	35-1*	Temp. Input X48/4
18-92	Process PID Clamped Output	33-18	Slave Marker Distance	33-90	X62 MCO CAN node ID	35-14	Term. X48/4 Filter Time Constant
18-93	Process PID Gain Scaled Output	33-19	Master Marker Type	33-91	X62 MCO CAN baud rate	35-15	Term. X48/4 Temp. Monitor
30-0*	Special Features	33-20	Slave Marker Type	33-94	X60 MCO RS485 serial termination	35-16	Term. X48/4 Low Temp. Limit
30-0*	Wobbler	33-21	Master Marker Tolerance Window	33-95	X60 MCO RS485 serial baud rate	35-17	Term. X48/4 High Temp. Limit
30-00	Wobble Mode	33-22	Slave Marker Tolerance Window	34-0*	MCO Data Readouts	35-2*	Temp. Input X48/7
30-01	Wobble Delta Frequency [Hz]	33-23	Start Behavior for Marker Sync	34-01	PCD Write Par.	35-24	Term. X48/7 Filter Time Constant
30-02	Wobble Delta Frequency [%]	33-24	Marker Number for Fault	34-02	PCD 1 Write to MCO	35-25	Term. X48/7 Temp. Monitor
30-03	Wobble Delta Freq. Scaling Resource	33-25	Marker Number for Ready	34-03	PCD 2 Write to MCO	35-26	Term. X48/7 Low Temp. Limit
30-04	Wobble Jump Frequency [Hz]	33-26	Velocity Filter	34-04	PCD 3 Write to MCO	35-27	Term. X48/7 High Temp. Limit
30-05	Wobble Jump Frequency [%]	33-27	Offset Filter Time	34-05	PCD 4 Write to MCO	35-2*	Temp. Input X48/10
30-06	Wobble Jump Time	33-28	Marker Filter Configuration	34-06	PCD 5 Write to MCO	35-34	Term. X48/10 Filter Time Constant
30-07	Wobble Sequence Time	33-29	Filter Time for Marker Filter	34-07	PCD 6 Write to MCO	35-35	Term. X48/10 Temp. Monitor
30-08	Wobble Up/Down Time	33-30	Maximum Marker Correction	34-08	PCD 7 Write to MCO	35-36	Term. X48/10 Low Temp. Limit
30-09	Wobble Random Function	33-31	Synchronization Type	34-09	PCD 8 Write to MCO	35-37	Term. X48/10 High Temp. Limit
30-10	Wobble Ratio	33-32	Feed Forward Velocity Adaptation	34-10	PCD 9 Write to MCO	35-4*	Analog Input X48/2
30-11	Wobble Random Ratio Max.	33-33	Velocity Filter Window	34-11	PCD 10 Write to MCO	35-42	Term. X48/2 Low Current
30-12	Wobble Random Ratio Min.	33-34	Slave Marker filter time	34-2*	PCD Read Par.	35-43	Term. X48/2 High Current
30-2*	Adv. Start Adjust	33-40	Limit Handling	34-21	PCD 1 Read from MCO	35-44	Term. X48/2 Low Ref./Feedb. Value
30-20	High Starting Torque Time [s]	33-41	Behavior at End Limit Switch	34-22	PCD 2 Read from MCO	35-45	Term. X48/2 High Ref./Feedb. Value
30-21	High Starting Torque Current [%]	33-42	Negative Software End Limit	34-23	PCD 3 Read from MCO	35-46	Term. X48/2 Filter Time Constant
30-22	Locked Rotor Protection	33-43	Positive Software End Limit	34-24	PCD 4 Read from MCO	42-1*	Safety Functions
30-23	Locked Rotor Detection Time [s]	33-44	Negative Software End Limit Active	34-25	PCD 5 Read from MCO	42-1*	Speed Monitoring
30-8*	Compatibility (I)	33-45	Positive Software End Limit Active	34-26	PCD 6 Read from MCO	42-10	Measured Speed Source
30-81	Brake Resistor (ohm)	33-46	Time in Target Window	34-27	PCD 7 Read from MCO	42-11	Encoder Resolution
30-83	Speed PID Proportional Gain	33-47	Target Window Limit/Value	34-28	PCD 8 Read from MCO	42-12	Encoder Direction
30-84	Process PID Proportional Gain	33-50	Size of Target Window	34-29	PCD 9 Read from MCO	42-13	Gear Ratio
31-1*	Bypass Option	33-51	I/O Configuration	34-30	PCD 10 Read from MCO	42-14	Feedback Type
31-00	Bypass Mode	33-52	Terminal X57/1 Digital Input	34-4*	Inputs & Outputs	42-15	Feedback Filter
31-01	Bypass Start Time Delay	33-53	Terminal X57/2 Digital Input	34-40	Digital Inputs	42-17	Tolerance Error
31-02	Bypass Trip Time Delay	33-54	Terminal X57/3 Digital Input	34-41	Digital Outputs	42-18	Zero Speed Timer
31-03	Test Mode Activation	33-55	Terminal X57/4 Digital Input	34-5*	Process Data	42-19	Zero Speed Limit
31-10	Bypass Status Word	33-56	Terminal X57/5 Digital Input	34-50	Actual Position	42-2*	Safe Input
31-11	Bypass Running Hours	33-57	Terminal X57/6 Digital Input	34-51	Commanded Position	42-20	Safe Function
31-19	Remote Bypass Activation	33-58	Terminal X57/7 Digital Input	34-52	Actual Master Position	42-21	Type
32-0*	MCO Basic Settings	33-59	Terminal X57/8 Digital Input	34-53	Slave Index Position	42-22	Discrepancy Time
32-0*	Encoder 2	33-60	Terminal X57/9 Digital Input	34-54	Master Index Position	42-23	Stable Signal Time
32-00	Incremental Signal Type	33-61	Terminal X59/1 and X59/2 Mode	34-55	Curve Position	42-24	Restart Behaviour
32-01	Incremental Resolution	33-62	Terminal X59/1 Digital Input	34-56	Track Error	42-3*	General
32-02	Absolute Protocol	33-63	Terminal X59/2 Digital Input	34-57	Synchronizing Error	42-30	External Failure Reaction
32-03	Absolute Resolution	33-64	Terminal X59/3 Digital Output	34-58	Actual Velocity	42-31	Reset Source
32-04	Absolute Encoder Baudrate X55	33-65	Terminal X59/4 Digital Output	34-59	Actual Master Velocity	42-33	Parameter Set Name
32-05	Absolute Encoder Data Length	33-66	Terminal X59/5 Digital Output	34-60	Synchronizing Status	42-35	S-CRC Value
32-06	Absolute Encoder Clock Frequency	33-67	Terminal X59/6 Digital Output	34-61	Axis Status	42-36	Level 1 Password
32-07	Absolute Encoder Clock Generation	33-68	Terminal X59/7 Digital Output	34-62	Program Status	42-4*	SS1
32-08	Absolute Encoder Cable Length	33-69	Terminal X59/8 Digital Output	34-64	MCO 302 Status	42-40	Type
32-09	Encoder Monitoring	33-70	Terminal X59/9 Digital Output	34-65	MCO 302 Control	42-41	Ramp Profile
32-10	Rotational Direction	33-8*	Global Parameters	34-7*	Diagnosis readouts	42-42	Delay Time
32-11	User Unit Denominator	33-80	Activated Program Number	34-70	MCO Alarm Word 1	42-43	Delta T
32-12	User Unit Numerator	33-81	Power-up State	34-71	MCO Alarm Word 2	42-44	Deceleration Rate
32-13	Enc.2 Control	33-82	Drive Status Monitoring	35-0*	Sensor Input Option	42-45	Delta V
32-14	Enc.2 node ID	33-83	Behavior After Error	35-0*	Temp. Input Mode	42-46	Zero Speed
		33-84	Behavior After Error	35-01	Term. X48/4 Temp. Unit	42-47	Ramp Time
						42-48	S-ramp Ratio at Decel. Start



42-49 S-ramp Ratio at Decel. End
42-5* SLS
42-50 Cut Off Speed
42-51 Speed Limit
42-52 Fail Safe Reaction
42-53 Start Ramp
42-54 Ramp Down Time
42-8* Status
42-80 Safe Option Status
42-81 Safe Option Status 2
42-85 Active Safe Func.
42-86 Safe Option Info
42-89 Customization File Version
42-9* Special
42-90 Restart Safe Option

Index

A

Abbreviations..... 79

AC input..... 7, 16

AC line power..... 7, 16

AC line voltage..... 23, 38

AC waveform..... 7

Additional Resources..... 4

Alarm Log..... 24

Alarms..... 39

AMA..... 29, 37, 41, 45

AMA with T27 Connected..... 31

AMA without T27 Connected..... 31

Ambient Conditions..... 64

Analog input..... 17, 40

Analog Inputs..... 66

Analog output..... 17

Analog Output..... 67

Analog signal..... 40

Analog speed reference..... 32

Approvals..... 7

Auto On..... 24, 30, 37, 39

Auto-reset..... 23

B

Backplate..... 11

Braking..... 37, 43

C

Cable Lengths and Cross-sections..... 64

Cable Specifications..... 64

Certifications..... 7

Circuit breakers..... 21

Circuit Breakers..... 69

Clearance requirements..... 11

Closed-loop..... 19

Communication option..... 44

Conduit..... 21

Control card..... 40

Control Card Performance..... 68

Control Card, +10 V DC Output..... 67

Control Card, 24 V DC Output..... 67

Control Card, RS-485 Serial Communication..... 67

Control card, USB serial communication..... 68

Control Characteristics..... 68

Control signal..... 37

Control terminals..... 24, 27, 37, 39

Control wiring..... 12, 14, 18, 21

Conventions..... 79

Cooling..... 11

Cooling clearance..... 21

Current limit..... 50

Current rating..... 41

D

DC current..... 7, 38

DC link..... 41

Default settings..... 25

Digital input..... 19, 39, 41

Digital Inputs..... 65

Digital Output..... 67

Dimensions..... 77

Discharge time..... 9

Disconnect switch..... 22

Disposal Instruction..... 7

E

Electrical Installation..... 12

Electrical interference..... 12

EMC..... 12

EMC interference..... 14

Encoder Rotation..... 29

Environment..... 64

Exploded View..... 5

External alarm reset..... 34

External commands..... 7, 39

External controllers..... 4

External interlock..... 19

F

Fault log..... 24

FC..... 20

Feedback..... 19, 21, 38, 45

Floating delta..... 16

FLUX..... 36

Front cover tightening torque..... 78

Fuses..... 12, 21, 44, 69

G	
Ground connections.....	21
Ground wire.....	12
Grounded delta.....	16
Grounding.....	15, 16, 21, 22
H	
Hand On.....	24, 30
Harmonics.....	7
High voltage.....	8
I	
IEC 61800-3.....	16
Initialization.....	26
Input current.....	16
Input disconnect.....	16
Input power.....	7, 12, 14, 16, 21, 22, 39
Input signal.....	19
Input terminal.....	16, 19, 22, 40
Input voltage.....	22
Installation.....	18, 20, 21
Installation Environments.....	10
Intended Use.....	4
Interference isolation.....	21
Isolated line power.....	16
J	
Jumper.....	19
L	
Leakage current.....	9
Lifting.....	11
Line Power Supply.....	57, 58, 59
Line power supply (L1, L2, L3).....	63
Local control.....	23, 24, 37
Local control panel (LCP).....	23
Local start.....	30
M	
Main Menu.....	24
Maintenance.....	37
Manual initialization.....	26
MCT 10.....	17, 23
Mechanical Brake Control.....	19, 36
Mechanical Installation.....	10
Menu keys.....	23
Menu Keys.....	24
Menu structure.....	24
Modbus RTU.....	20
Motor cables.....	12, 0
Motor current.....	7, 23, 29, 45
Motor Current.....	23
Motor data.....	27, 41, 46, 50
Motor Data.....	29
Motor output.....	63
Motor power.....	12, 23, 45
Motor protection.....	4
Motor rotation.....	29
Motor speeds.....	26
Motor status.....	4
Motor thermistor.....	35
Motor wiring.....	14, 21
Mounting.....	11, 21
Multiple adjustable frequency drives.....	12, 0
N	
Nameplate.....	10
Navigation keys.....	23, 24, 26, 37
O	
Open-loop.....	19
Operation keys.....	23
Optional equipment.....	16, 19, 22
Output current.....	38, 41
Output Performance (U, V, W).....	63
Output terminal.....	22
Overcurrent protection.....	12
Overvoltage.....	38, 50
P	
Parameter Menu Structure.....	80
PELV.....	35
Phase loss.....	40
PM Motor.....	27
Potential equalization.....	13
Power connection.....	12

Power factor.....	7, 21	Storage.....	10
Power Ratings.....	77	Supply voltage.....	16, 17, 22, 44
Programming.....	19, 23, 24, 25, 40	Switch.....	19
Pulse start/stop.....	33	Switching frequency.....	38
Pulse/Encoder Inputs.....	66	Symbols.....	79
		System feedback.....	4
Q		T	
Qualified personnel.....	8	Terminal 53.....	19
Quick menu.....	23	Terminal 54.....	19, 47
Quick Menu.....	24	Thermal Protection.....	7
R		Thermistor.....	16, 35
Ramp-down time.....	50	Thermistor control wiring.....	16
Ramp-up time.....	50	Tightening covers.....	15
Reference.....	23, 31, 37, 38, 39	Tightening Terminals.....	76
Relay Outputs.....	68	Torque Characteristics.....	63
Remote commands.....	4	Torque limit.....	50
Remote reference.....	38	Transient protection.....	7
Reset.....	23, 24, 26, 39, 41, 47	Trip.....	39
RFI filter.....	16	Trip lock.....	39
RMS current.....	7	Troubleshooting.....	49
RS-485 network connection.....	35	U	
RS-485 Serial Communication.....	20	Unintended start.....	8
Run command.....	30	V	
Run permissive.....	38	Vibration.....	10
S		Voltage imbalance.....	40
Safe Torque Off.....	19	Voltage level.....	65
Safety.....	8	VVCplus.....	27
Serial communication.....	17, 24, 37, 38, 39	W	
Serial Communication.....	68	Warnings.....	39
Service.....	37	Weight.....	77
Setpoint.....	39	Windmilling.....	9
Set-up.....	24, 30	Wire sizes.....	12, 15
Shielded cable.....	14, 0 , 21	Wiring Schematic.....	13
Shock.....	10		
Short circuit.....	42		
SLC.....	36		
Sleep Mode.....	39		
Specifications.....	20		
Speed reference.....	19, 30, 32, 37		
Start/stop command.....	33		
Start-up.....	26		
Status mode.....	37		



www.danfoss.com/drives

.....
Danfoss shall not be responsible for any errors in catalogs, brochures or other printed material. Danfoss reserves the right to alter its products at any time without notice, provided that alterations to products already on order shall not require material changes in specifications previously agreed upon by Danfoss and the Purchaser. All trademarks in this material are property of the respective companies. Danfoss and the Danfoss logotype are trademarks of Danfoss A/S. All rights reserved.
.....

