



Operating Instructions

VLT[®] Compressor Drives CDS 302/CDS 303



Contents

1 Introduction	4
1.1 Introduction	4
1.1.1 Sequence of Operation	5
2 Safety Instructions and General Warnings	6
2.1 Safety and Warnings	6
2.1.1 High Voltage Warning	6
2.1.2 Caution	6
2.1.3 Disposal	6
2.1.4 Software Version	6
2.1.5 Safety Instructions	6
2.1.6 General Warning	7
2.1.7 Leakage Current	7
2.1.8 Residual Current Device	7
2.1.9 IT Mains	7
2.1.10 Avoid Unintended Start	7
2.2 Safe Torque Off	7
2.2.1 Terminal 37 Safe Torque Off Function	8
2.2.2 Safe Torque Off Commissioning Test	13
3 How to Install	14
3.1 Environment	14
3.1.1 Ambient Temperature and Altitude	14
3.1.2 Environmental Requirements for Mechanical Installation	14
3.2 Mechanical Installation	14
3.2.1 Accessory Bags	14
3.2.2 Mechanical Mounting	15
3.2.3 Mechanical Dimensions	16
3.3 Electrical Installation	17
3.3.1 Cables General	17
3.3.2 Removal of Knockouts for Extra Cables	17
3.3.3 Mains Connection for B1, B2 and B3	18
3.3.4 Mains connection for B4, C1 and C3	18
3.3.5 Motor Compressor Connection	20
3.3.6 Motor Compressors Cables	20
3.3.7 Electrical Installation of Motor Compressor Cables	21
3.3.8 Compressor Motor Protection	21
3.3.9 Access to Control Terminals	21

3.3.10 Basic Wiring Example	22
3.3.11 Electrical Installation, Control Cables	24
3.3.12 Electrical Installation - EMC Protection	26
3.3.13 Safety Ground Connection	28
3.3.14 Basic Examples of Control Connections	28
3.3.15 High-voltage Test	29
3.4 Fuses and Circuit Breakers	29
3.4.1 Fuses	29
3.4.2 Recommendations	29
3.4.3 CE Compliance	30
3.4.4 Fuse Specifications	30
3.5 Application Example	34
3.5.1 BASIC Cascade/Pack Controller	34
3.5.2 System Status and Operation	35
3.5.3 Pack Compressor Wiring Diagram	35
4 Quick Set-up	37
4.1 Quick Set-up	37
4.1.1 Basic Programming Procedures	37
4.1.2 Open Loop with External Reference	37
4.1.3 PID Closed Loop with 4-20 mA Pressure Transmitter	37
4.1.4 Other Compressor Features	39
5 How to Program	40
5.1 How to Program on the Graphical LCP	40
5.1.1 Control Panel	40
5.1.2 Display Lines	40
5.1.3 Display Contrast Adjustment	40
5.1.4 Indicator Lights	41
5.2 LCP Keys	41
5.2.1 Function Keys	41
5.2.2 Navigation Keys	41
5.2.3 Local Control Keys	41
5.2.4 Quick Transfer of Parameter Settings	42
5.2.5 Data Storage in LCP	42
5.2.6 Initialization to Default Settings	42
5.2.7 Data Transfer from LCP to Frequency Converter	43
5.2.8 Parameter Selection	44
5.2.9 Changing Data	45

5.2.10 Changing a Text Value	45
5.2.11 Changing a Group of Numeric Data Values	45
6 Parameter Descriptions	46
6.1 LCP Display	46
6.1.1 LCP Programming	46
6.2 Par. Group 0 - Operation and Display	47
6.3 Par. Group 1 - Load and Motor	53
6.4 Par. Group 3 - Reference/Ramps	54
6.5 Parameters: 4-** Limits/Warnings	59
6.6 Par. Group 5 - Digital In/Out	62
6.7 Par. Group 6 - Analog In/Out	72
6.8 Par. Group 7 - Controllers	76
6.9 Parameters: 8-** Communications and Options	81
6.10 Par. Group 13 - Smart Logic Control	85
6.11 Par. Group 14 - Special Functions	102
6.12 Par. Group 15 - Drive Information	105
6.13 Parameters: 16-** Data Readouts	106
6.14 Par. Group 25 - Cascade Controller	112
6.15 Par. Group 28 - Compressor Functions	122
6.16 Parameter Lists	127
6.16.1 Conversion	127
7 Troubleshooting	147
7.1 Status Messages	147
7.1.1 Warnings/Alarm Messages	147
8 General Specifications	161
8.1.1 Mains Supply 3x200-240 V AC	161
8.1.2 Mains Supply 3x380-480 V AC	162
8.1.3 Mains Supply 3x525-600 V AC	163
Index	168

1 Introduction

1.1 Introduction

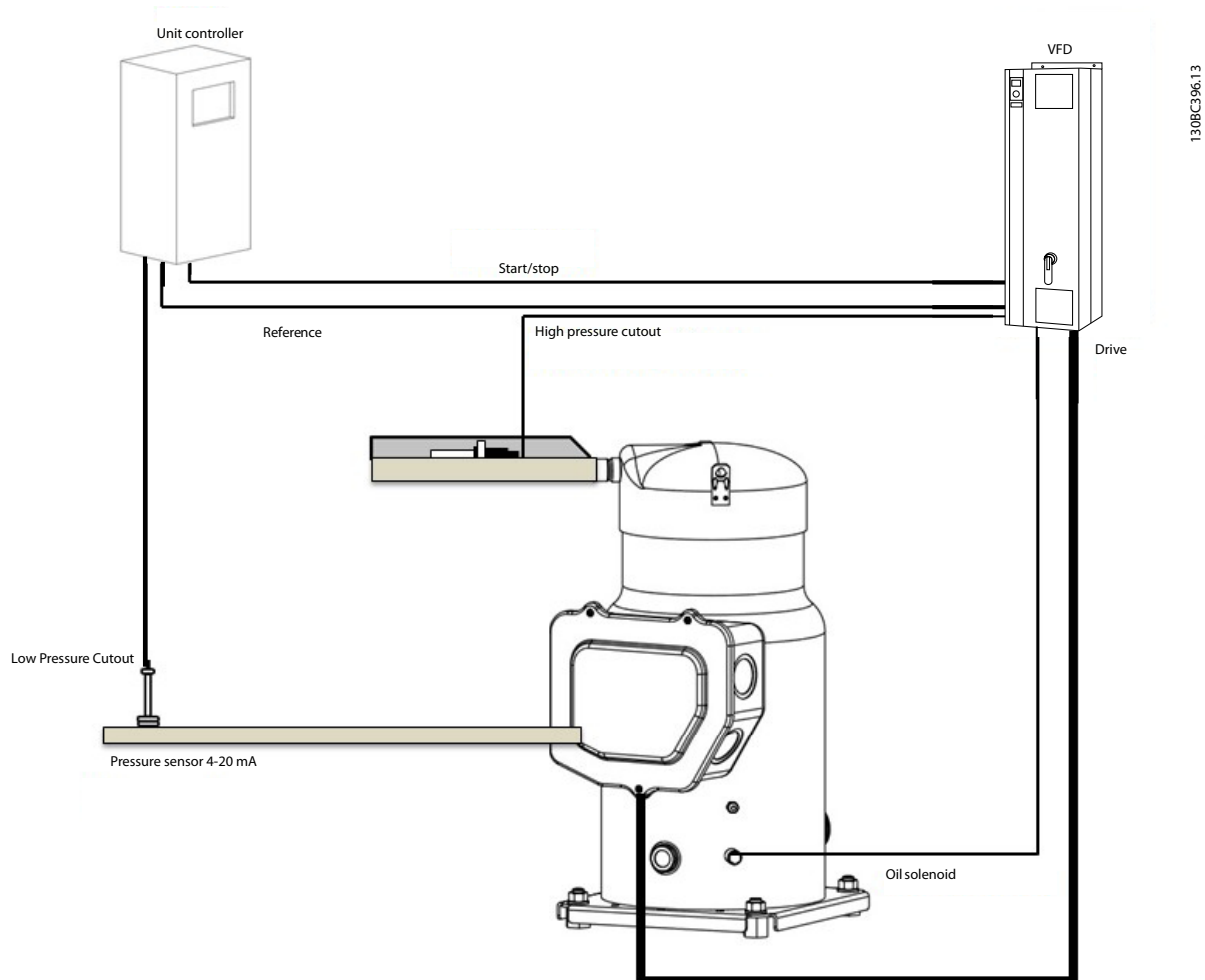

Figure 1.1 Compressor Drive System

The VLT® Compressor Drives utilize and combine Danfoss design and manufacturing expertise. Our extensive application knowledge of refrigeration, air conditioning, and motion controls ensures an optimized product design and package solution:

- A “plug & play” solution
- Operational efficiency
- Flexibility & best control accuracy
- Innovative and reliable solution

The frequency converter is 100% preset for speed open loop configuration with 0-10 V reference corresponding to

1800-5400 RPM for CDS 302 and 1500-6000 RPM for CDS 303.

The dedicated frequency converter functionality includes:

- **Start Up**
Once the frequency converter has a start command, the compressor runs up to 3000 RPM and remains at that speed for 10 s. Once this initial time is complete, the frequency converter slowly ramps to the reference speed.
- **Shut Down**
The stop command bypasses the normal ramp time and the frequency converter ramps the compressor to stop fast.
- **Short Cycle Prevention**
The frequency converter has a minimum running time of 12 s, with an interval between starts of 5 minutes (300 s). The short cycle delay values are adjustable in parameter group 28-0* *Short Cycle Protection*.
- **Oil Injection**
The frequency converter cycles a solenoid valve via its relay 1. This cycling ensures that the oil is distributed to the scroll set, improves tightness, and reduces internal gas leakage during the compression process.
- **Oil Management**
If compressor speed is below 3000 RPM for a determined amount of time (within 60 minutes), the boost cycle runs the compressor back to 4200 RPM for a determined amount of time (within 90 s). The maximum time between fixed boosts is limited to a determined amount of time (within 24 hours).
- **Discharge Temperature Limit**
If the discharge temperature exceeds the warning level of 266 °F, the compressor drops in speed by 10 Hz for the next 3 minutes. The compressor continues to drop 10 Hz for each 3 minutes for as long as the temperature is over the warning level. If the discharge temperature exceeds the emergency level of 293 °C, the compressor is stops.
- **Crankcase Heater**
On VSH088 and VSH117, when the compressor is stopped, the frequency converter provides a DC current to the compressor motor. The DC current keeps the oil warm and an external crankcase heater is not needed.
VSH170 needs an external crankcase heater (surface sump heater or belt type).
- **Low Pressure Switch**
An LP switch is mandatory with the frequency converter compressor in any type of application.

- **High Pressure Switch**

The high-pressure switch must be connected to input terminal 37 of the frequency converter in series with the other safety devices.

1.1.1 Sequence of Operation

All compressor types have strong demands of speed limits to ensure the oil lubrication of the bearings. Therefore, fast acceleration from standstill to minimum speed with a special start ramp is important, when a start command is given. This is also the reason why the Compressor Drive trips with an alarm [A49] *Speed Limit*, if the speed falls below minimum speed e.g. when the current limit controller reduces the speed due to a high load. This alarm is reset automatically after 30 s and the compressor restarts.

If a rotor is blocked, the Compressor Drive trips with an alarm [A18] *Start failed*, if the speed fails to get above the minimum speed limit for the compressor within 2 s. This alarm is reset automatically after 30 s and the compressor restarts.

The manufacturer sets up the necessary start settings, motor data and all the other preferred settings for each compressor type/size. Automatically set up the values by selecting the actual compressor in *1-13 Compressor Selection*.

2

2 Safety Instructions and General Warnings

2.1 Safety and Warnings

2.1.1 High Voltage Warning

⚠ WARNING

The voltage of the frequency converter is dangerous whenever the converter is connected to mains. Incorrect fitting of the motor or frequency converter may damage the equipment, or cause serious injury, or death. It is essential to comply with the instructions in this manual as well as local and national rules and safety regulations.

⚠ WARNING

Installation in high altitudes:
By altitudes above 2 km (6561 ft), contact Danfoss regarding PELV.

2.1.2 Caution

⚠ CAUTION

The VLT® Compressor Drives DC link capacitors remain charged after power has been disconnected. To avoid an electrical shock hazard, disconnect the frequency converter from the mains before carrying out maintenance. Wait at least as follows before doing service on the frequency converter:
CDS 302 and CDS 303: 11-22 kW 15 minutes
High voltage can be present on the DC link even when the LEDs are turned off.

2.1.3 Disposal



Figure 2.1

Drive

Do not dispose of equipment containing electrical components together with domestic waste. It must be collected separately with Electrical and Electronic Waste according to local and national legislation.

Compressors

Do not to throw away a used compressor, but dispose of it and its oil at a specialized recycling company site.

NOTICE!

Imposed limitations on the output frequency (due to export control regulations):

From software versions 2.4x (CDS 302) and 1.0x (CDS 303), the output frequency of the frequency converter is limited to 590 Hz.

2.1.4 Software Version

CDS 302 Operating Instructions Software version: 2.4x



These Operating Instructions can be used for all CDS 302 Compressor Drives® with software version 2.4x. The software version number can be read in *parameter 15-43 Software Version*.

CDS 303 Operating Instructions Software version: 1.0x



These Operating Instructions can be used for all CDS 303 Compressor Drives® with software version 1.0x. The software version number can be read in *parameter 15-43 Software Version*.

2.1.5 Safety Instructions

- Make sure that the frequency converter is properly connected to ground
- Do not remove mains plugs or motor plugs while the frequency converter is connected to mains
- Protect personnel against supply voltage
- Protect the motor against overloading according to local and national regulations
- Motor overload protection is included in the default settings

- The ground leakage current exceeds 3.5 mA
- The [Off] key is not a safety switch. It does not disconnect the frequency converter from mains

2.1.6 General Warning

⚠ WARNING

Touching the electrical parts may be fatal - even after the equipment has been disconnected from mains. Also make sure that other voltage inputs have been disconnected, such as load-sharing (linkage of DC intermediate circuit).

Using VLT® Compressor Drives: Wait at least 15 minutes. Shorter time is allowed only if indicated on the nameplate for the specific unit.

2.1.7 Leakage Current

⚠ CAUTION

The ground leakage current from the frequency converter exceeds 3.5 mA. Ensure good mechanical ground connection (terminal 95) to the ground cable. Use at least 10 mm² cable cross section or 2 times rated ground wires terminated separately.

2.1.8 Residual Current Device

⚠ CAUTION

This product can cause a DC current in the protective conductor. Where a ground fault interrupter (GFI) is used for extra protection, only use an GFI of Type B (time delayed) on the supply side of this product. See also *RCD Application Note, MN90G*. Protective grounding of the frequency converter and the use of RCDs must always follow local and national regulations.

2.1.9 IT Mains

⚠ CAUTION

Do not connect 400 V frequency converters with RFI-filters to mains supplies with a voltage between phase and ground of more than 440 V. For IT mains and delta ground (grounded leg), mains voltage may exceed 440 V between phase and ground. To disconnect the internal RFI capacitors from the RFI filter to ground, use *14-50 RFI 1* on the frequency converter. This procedure reduces the RFI performance to A2 level.

2.1.10 Avoid Unintended Start

While the frequency converter is connected to mains, the motor can be started/stopped using:

- digital commands
- bus commands
- references
- via the Local Control Panel (LCP)

Disconnect the frequency converter from mains whenever personal safety considerations make it necessary to avoid unintended start. To avoid unintended start, always press [OFF] before changing parameters. An electronic fault, temporary overload, a fault in the mains supply, or lost motor connection may cause a stopped motor to start. A frequency converter with Safe Torque Off provides a certain degree of protection against such unintended start, if the Safe Torque Off Terminal 37 is on low voltage level or disconnected.

2.2 Safe Torque Off

The frequency converter can perform the safety function *Safe Torque Off* (STO, as defined by EN IEC 61800-5-2¹) and *Stop Category 0* (as defined in EN 60204-1²). Before integration and use of Safe Torque Off in an installation, perform a thorough risk analysis to determine whether the Safe Torque Off functionality and safety levels are appropriate and sufficient. Safe Torque Off is designed and approved suitable for the requirements of:

- Safety Category 3 in EN 954-1 (and EN ISO 13849-1)
- Performance Level "d" in EN ISO 13849-1:2008
- SIL 2 Capability in IEC 61508 and EN 61800-5-2
- SILCL 2 in EN 62061

¹) Refer to EN IEC 61800-5-2 for details of Safe torque off (STO) function.

²) Refer to EN IEC 60204-1 for details of stop category 0 and 1.

Activation and Termination of Safe Torque Off

The Safe Torque Off (STO) function is activated by removing the voltage at terminal 37 of the safe inverter. By connecting the safe inverter to external safety devices providing a safe delay, an installation for a Safe Torque Off Category 1 can be obtained. The Safe Torque Off function can be used for asynchronous, synchronous, and permanent magnet motors.

⚠ WARNING

After installation of Safe Torque Off (STO), a commissioning test as specified in section *Safe Torque Off Commissioning Test* in the Design Guide must be performed. A passed commissioning test is mandatory after first installation and after each change to the safety installation.

Safe Torque Off Technical Data

The following values are associated to the different types of safety levels:

Reaction time for T37

- Maximum reaction time: 10 ms

Reaction time = delay between de-energizing the STO input and switching off the frequency converter output bridge.

Data for EN ISO 13849-1

- Performance Level "d"
- $MTTF_d$ (Mean Time To Dangerous Failure): 24816 years
- DC (Diagnostic Coverage): 99%
- Category 3
- Lifetime 20 years

Data for EN IEC 62061, EN IEC 61508, EN IEC 61800-5-2

- SIL 2 Capability, SILCL 2
- PFH (Probability of Dangerous failure per Hour)= $7e-10FIT=7e-19/h$
- SFF (Safe Failure Fraction) >99%
- HFT (Hardware Fault Tolerance)=0 (1001 architecture)
- Lifetime 20 years

Data for EN IEC 61508 low demand

- PFD_{avg} for one-year proof test: 3, $07E-14$
- PFD_{avg} for three year proof tests: 9, $20E-14$
- PFD_{avg} for five year proof tests: 1, $53E-13$

No maintenance of the STO functionality is needed.

Take the necessary security measures, e.g. installation in a closed cabinet that is only accessible for skilled personnel.

SISTEMA Data

Functional safety data is available via a data library for use with the SISTEMA calculation tool from the IFA (Institute for Occupational Safety and Health of the German Social Accident Insurance), and data for manual calculation. The library is permanently completed and extended.

Abbrev.	Ref.	Description
Cat.	EN 954-1	Category, level "B, 1-4"
FIT		Failure In Time: $1E-9$ hours
HFT	IEC 61508	Hardware Fault Tolerance: HFT = n means, that n+1 faults could cause a loss of the safety function
MTTFd	EN ISO 13849-1	Mean Time To Failure - dangerous. Unit: years
PFH	IEC 61508	Probability of Dangerous Failures per Hour. Consider the PFH value when the safety device is operated in high demand (more often than once per year); or operated in continuous mode, where the frequency of demands for operation made on a safety-related system is greater than one per year.
PL	EN ISO 13849-1	Discrete level used to specify the ability of safety-related parts of control systems to perform a safety function under foreseeable conditions. Levels a-e.
SFF	IEC 61508	Safe Failure Fraction [%]; Percentage part of safe failures and dangerous detected failures of a safety function or a subsystem related to all failures.
SIL	IEC 61508	Safety Integrity Level
STO	EN 61800-5-2	Safe Torque Off
SS1	EN 61800-5-2	Safe Torque Off 1

Table 2.1 Abbreviations Related to Functional Safety

The PFD_{avg} value (Probability of Failure on Demand) Failure probability in the event of a request of the safety function.

2.2.1 Terminal 37 Safe Torque Off Function

The frequency converter is available with Safe Torque Off functionality via control terminal 37. Safe Torque Off disables the control voltage of the power semiconductors of the frequency converter output stage. This in turn prevents generating the voltage required to rotate the motor. When the Safe Torque Off (T37) is activated, the frequency converter issues an alarm, trips the unit, and coasts the motor to a stop. Manual restart is required. The Safe Torque Off function can be used as an emergency stop for the frequency converter. In normal operating mode when Safe Torque Off is not required, use the regular stop function instead. When automatic restart is used, ensure the requirements of ISO 12100-2 paragraph 5.3.2.5 are fulfilled.

Liability Conditions

Ensure that qualified personnel installs and operates the Safe Torque Off function:

- Read and understand the safety regulations concerning health and safety/accident prevention
- Understand the generic and safety guidelines given in this description and the extended description in the relevant *Design Guide*
- Have a good knowledge of the generic and safety standards applicable to the specific application

User is defined as:

- integrator
- operator
- service technician
- maintenance technician

Standards

Use of Safe Torque Off on terminal 37 requires fulfilling of all provisions for safety, including relevant laws, regulations and guidelines. The optional Safe Torque Off function complies with the following standards.

- IEC 60204-1: 2005 category 0 – uncontrolled stop
- IEC 61508: 1998 SIL2
- IEC 61800-5-2: 2007 – safe torque off (STO) function
- IEC 62061: 2005 SIL CL2
- ISO 13849-1: 2006 Category 3 PL d
- ISO 14118: 2000 (EN 1037) – prevention of unexpected startup

The information and instructions of the instruction manual are not sufficient for a proper and safe use of the Safe Torque Off functionality. The related information and instructions of the relevant *Design Guide* must be followed.

Protective Measures

- Qualified and skilled personnel are required for installation and commissioning of safety engineering systems
- The unit must be installed in an IP54 cabinet or in an equivalent environment. In special applications, a higher IP degree is required
- The cable between terminal 37 and the external safety device must be short circuit protected according to ISO 13849-2 table D.4
- When external forces influence the motor axis (for example, suspended loads), more measures are

required (for example, a safety holding brake) to eliminate potential hazards

Safe Torque Off Installation and Set-Up**⚠ WARNING****SAFE TORQUE OFF FUNCTION!**

The Safe Torque Off function does NOT isolate mains voltage to the frequency converter or auxiliary circuits. Perform work on electrical parts of the frequency converter or the motor only after isolating the mains voltage supply and waiting the length of time specified in *chapter 2.1 Safety and Warnings*. Failure to isolate the mains voltage supply from the unit and waiting the time specified could result in death or serious injury.

- It is not recommended to stop the frequency converter by using the Safe Torque Off function. If a running frequency converter is stopped by using the function, the unit trips and stops by coasting. If unacceptable or dangerous, use another stop mode to stop the frequency converter and machinery, before using this function. Depending on the application, a mechanical brake can be required.
- For synchronous and permanent magnet motor frequency converters, in a multiple IGBT power semiconductor failure: In spite of the activation of the Safe Torque Off function, the system can produce an alignment torque which maximally rotates the motor shaft by $180/p$ degrees. p denotes the pole pair number.
- This function is suitable for performing mechanical work on the system or affected area of a machine only. It does not provide electrical safety. Do not use this function as a control for starting and/or stopping the frequency converter.

To perform a safe installation of the frequency converter, follow these steps:

1. Remove the jumper wire between control terminals 37 and 12 or 13. Cutting or breaking the jumper is not sufficient to avoid short-circuiting. (See jumper on *Figure 2.2*.)
2. Connect an external Safety monitoring relay via a NO safety function to terminal 37 (Safe Torque Off) and either terminal 12 or 13 (24 V DC). Follow the instruction for the safety device. The Safety monitoring relay must comply with Category 3 /PL "d" (ISO 13849-1) or SIL 2 (EN 62061).

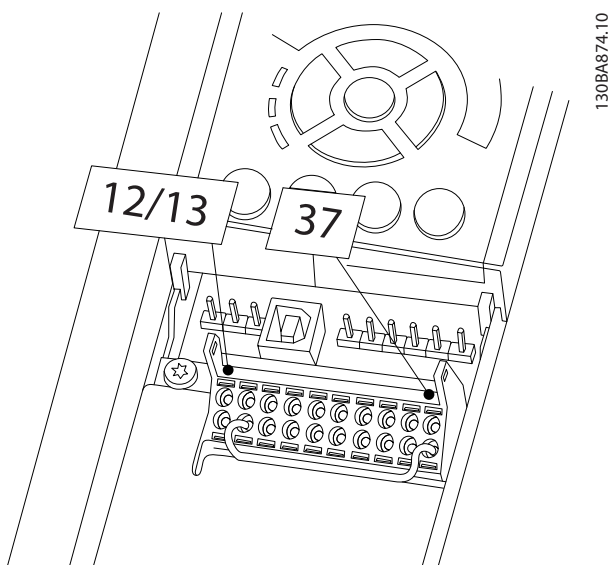

Figure 2.2 Jumper between Terminal 12/13 (24 V) and 37

130BA874.10

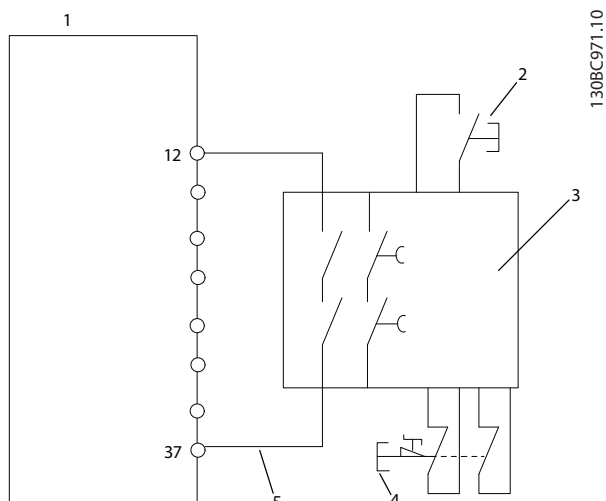

Figure 2.3 Installation to Achieve a Stopping Category 0 (EN 60204-1) with Cat. 3 /PL "d" (ISO 13849-1) or SIL 2 (EN 62061).

130BC971.10

1	Frequency converter
2	[Reset] key
3	Safety relay (cat. 3, PL d or SIL2)
4	Emergency stop button
5	Short-circuit protected cable (if not inside installation IP54 cabinet)

Table 2.2 Legend to Figure 2.3

Safe Torque Off Commissioning Test

After installation and before first operation, perform a commissioning test of the installation using Safe Torque

Off. Moreover, perform the test after each modification of the installation.

Example with STO

A safety relay evaluates the E-Stop button signals and triggers an STO function on the frequency converter in the event of an activation of the E-Stop button (See Figure 2.4). This safety function corresponds to a category 0 stop (uncontrolled stop) in accordance with IEC 60204-1. If the function is triggered during operation, the motor runs down in an uncontrolled manner. The power to the motor is safely removed, so that no further movement is possible. It is not necessary to monitor plant at a standstill. If an external force effect can occur, provide additional measures to prevent any potential movement (for example mechanical brakes).

NOTICE!

For all applications with Safe Torque Off it is important that short circuit in the wiring to T37 can be excluded. Exclude the short circuit as described in EN ISO 13849-2 D4 by the use of protected wiring (shielded or segregated).

Example with SS1

SS1 corresponds to a controlled stop, stop category 1 according to IEC 60204-1 (see Figure 2.5). When activating the safety function, the frequency converter performs a normal controlled stop. This can be activated through terminal 27. After the safe delay time has expired on the external safety module, the STO will be triggered and terminal 37 will be set low. Ramping down as configured in the frequency converter. If the frequency converter is not stopped after the safe delay time, the activation of STO will coast the frequency converter.

NOTICE!

When using the SS1 function, the brake ramp of the frequency converter is not monitored with respect to safety.

Example with Category 4/PL e application

Where the safety control system design requires two channels for the STO function to achieve Category 4/PL e, implement one channel via Safe Torque Off T37 (STO) and the other by a contactor. Connect the contactor in either the frequency converter input or output power circuits and controlled by the Safety relay (see Figure 2.6). The contactor must be monitored through an auxiliary guided contact, and connected to the reset input of the Safety Relay.

Paralleling of Safe Torque Off input the one Safety Relay

Safe Torque Off inputs T37 (STO) may be connected directly if it is required to control multiple frequency converters from the same control line via one Safety Relay

(see Figure 2.7). Connecting inputs increases the probability of a fault in the unsafe direction. A fault in one frequency converter can result in all frequency converters becoming enabled. The probability of a fault for T37 is so low, that the resulting probability still meets the requirements for SIL2.

1	Frequency converter
2	[Reset] key
3	Safety relay
4	Emergency stop

Table 2.4 Legend to Figure 2.5

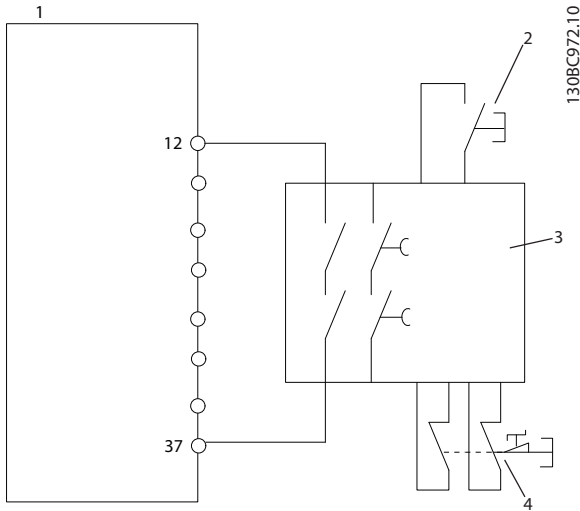

Figure 2.4 STO Example

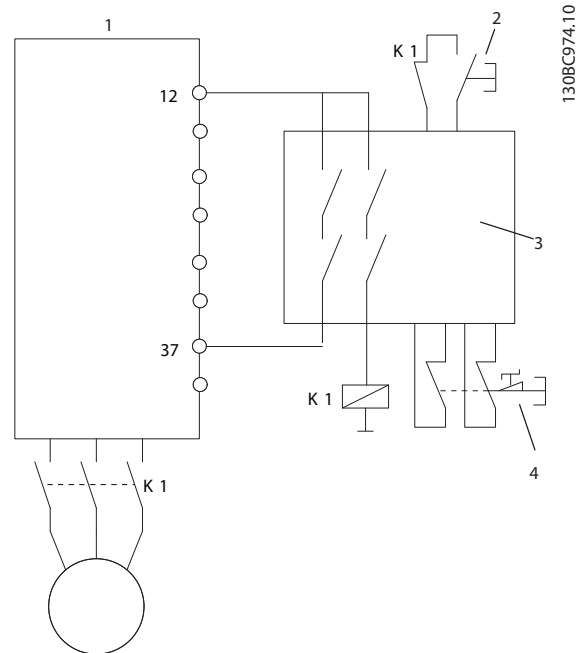

Figure 2.6 STO Category 4 Example

1	Frequency converter
2	[Reset] key
3	Safety relay
4	Emergency stop

Table 2.3 Legend to Figure 2.4

1	Frequency converter
2	[Reset] key
3	Safety relay
4	Emergency stop

Table 2.5 Legend to Figure 2.6

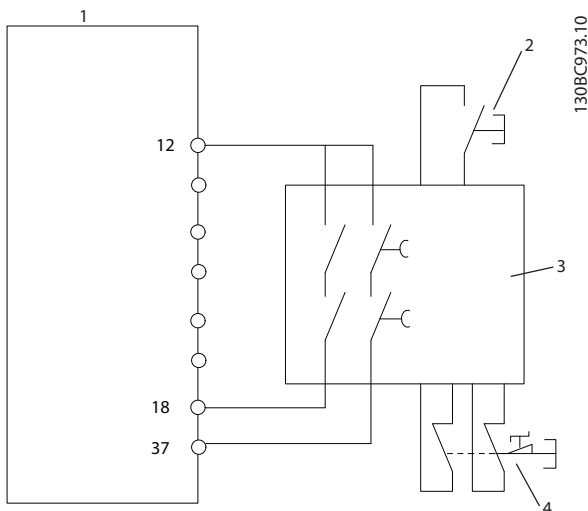

Figure 2.5 SS1 Example

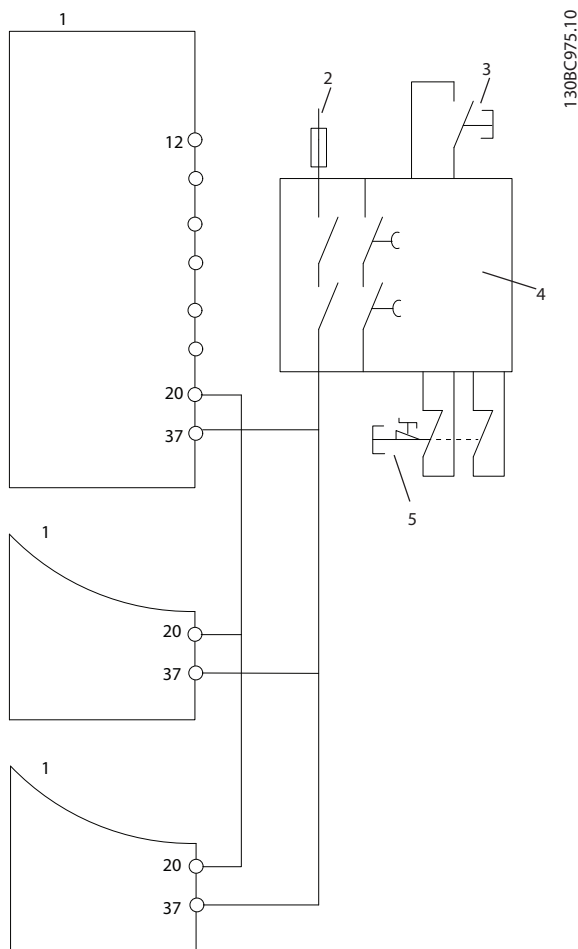

Figure 2.7 Paralleling of Multiple Drives Example

1	Frequency converter
2	24 V DC
3	[Reset] key
4	Safety relay
5	Emergency stop

Table 2.6 Legend to Figure 2.7

⚠ WARNING

Safe Torque Off activation (that is removal of 24 V DC voltage supply to terminal 37) does not provide electrical safety. The Safe Torque Off function itself is therefore not sufficient to implement the Emergency-Off function as defined by EN 60204-1. Emergency-Off requires measures of electrical isolation, for example, by switching off mains via an additional contactor.

1. Activate the Safe Torque Off function by removing the 24 V DC voltage supply to the terminal 37.
2. After activation of Safe Torque Off (that is, after the response time), the frequency converter coasts (stops creating a rotational field in the motor). The response time is typically less than 10 ms.

The frequency converter is guaranteed not to restart creation of a rotational field by an internal fault (in accordance with Cat. 3 of EN 954-1, PL d acc. EN ISO 13849-1 and SIL 2 acc. EN 62061). After activation of Safe Torque Off, the display shows the text "Safe Stop activated". The associated help text says, "Safe Stop has been activated. This means that the Safe Torque Off has been activated, or that normal operation has not been resumed yet after Safe Torque Off activation".

NOTICE!

The requirements of Cat. 3 (EN 954-1)/PL "d" (ISO 13849-1) are only fulfilled while 24 V DC supply to terminal 37 is kept removed or low by a safety device which itself fulfills Cat. 3 (EN 954-1) PL "d" (ISO 13849-1). If external forces act on the motor, it must not operate without additional measures for fall protection. External forces can arise for example, in the event of vertical axis (suspended loads) where an unwanted movement, for example caused by gravity, could cause a hazard. Fall protection measures can be additional mechanical brakes.

By default the Safe Torque Off function is set to an Unintended Restart Prevention behaviour. Therefore, to resume operation after activation of Safe Torque Off,

1. reapply 24 V DC voltage to terminal 37 (text Safe Torque Off activated is still displayed)
2. create a reset signal (via bus, Digital I/O, or [Reset] key).

The Safe Torque Off function can be set to an Automatic Restart behaviour. Set the value of *parameter 5-19 Terminal 37 Safe Stop* from default value [1] to value [3]. Automatic Restart means that Safe Torque Off is terminated, and normal operation is resumed, as soon as the 24 V DC are applied to Terminal 37. No Reset signal is required.

⚠ WARNING

Automatic Restart Behaviour is permitted in one of the two situations:

1. The Unintended Restart Prevention is implemented by other parts of the Safe Torque Off installation.
2. A presence in the dangerous zone can be physically excluded when Safe Torque Off is not activated. In particular, paragraph 5.3.2.5 of ISO 12100-2 2003 must be observed

2.2.2 Safe Torque Off Commissioning Test

After installation and before first operation, perform a commissioning test of an installation or application, using Safe Torque Off.

Perform the test again after each modification of the installation or application involving the Safe Torque Off.

NOTICE!

A passed commissioning test is mandatory after first installation and after each change to the safety installation.

The commissioning test (select one of cases 1 or 2 as applicable):

Case 1: Restart prevention for Safe Torque Off is required (that is Safe Torque Off only where parameter 5-19 Terminal 37 Safe Stop is set to default value [1], or combined Safe Torque Off and MCB 112 where parameter 5-19 Terminal 37 Safe Stop is set to [6] PTC 1 & Relay A or [9] PTC 1 & Relay W/A):

1.1 Remove the 24 V DC voltage supply to terminal 37 using the interrupt device while the frequency converter drives the motor (that is mains supply is not interrupted). The test step is passed when

- the motor reacts with a coast, and
- the mechanical brake is activated (if connected)
- the alarm "Safe Torque Off [A68]" is displayed in the LCP, if mounted

1.2 Send Reset signal (via Bus, Digital I/O, or [Reset] key). The test step is passed if the motor remains in the Safe Torque Off state, and the mechanical brake (if connected) remains activated.

1.3 Reapply 24 V DC to terminal 37. The test step is passed if the motor remains in the coasted

state, and the mechanical brake (if connected) remains activated.

1.4 Send Reset signal (via Bus, Digital I/O, or [Reset] key). The test step is passed when the motor becomes operational again.

The commissioning test is passed if all four test steps 1.1, 1.2, 1.3 and 1.4 are passed.

Case 2: Automatic Restart of Safe Torque Off is wanted and allowed (that is, Safe Torque Off only where parameter 5-19 Terminal 37 Safe Stop is set to [3], or combined Safe Stop and MCB 112 where parameter 5-19 Terminal 37 Safe Stop is set to [7] PTC 1 & Relay W or [8] PTC 1 & Relay A/W):

2.1 Remove the 24 V DC voltage supply to terminal 37 by the interrupt device while the frequency converter drives the motor (that is mains supply is not interrupted). The test step is passed when

- the motor reacts with a coast, and
- the mechanical brake is activated (if connected)
- the alarm "Safe Stop [A68]" is displayed in the LCP, if mounted

2.2 Reapply 24 V DC to terminal 37.

If the motor becomes operational again, The test step is passed. If both test steps 2.1 and 2.2 are passed, the commissioning test is passed.

NOTICE!

See warning on the restart behaviour in chapter 2.2.1 Terminal 37 Safe Torque Off Function

⚠ WARNING

The Safe Torque Off function can be used for asynchronous, synchronous and permanent magnet motors. Two faults can occur in the power semiconductor of the frequency converter. When using synchronous or permanent magnet motors a residual rotation can result from the faults. The rotation can be calculated to Angle = $360 / (\text{Number of Poles})$. The application using synchronous or permanent magnet motors must take this residual rotation into consideration and ensure that it does not pose a safety risk. This situation is not relevant for asynchronous motors.

3 How to Install

3

3.1 Environment

3.1.1 Ambient Temperature and Altitude

The normal ambient temperature supported by the CDS is -14000000 °F to +122 °F without derating. The CDS operates normally down to -4 °F with only the LCP display function impaired but without performance reduction.

For ambient temperatures above +122 °F, it is mandatory to integrate the derating output factor for the maximum compressor electrical motor power/current.

For altitudes above 3280 ft (1000 m), apply derating as shown in Table 3.1.

For more details on derating due to environmental factors, contact Danfoss technical support.

Altitude [ft/m]	Derating factor
3280/1000	1
4921/1500	0.95
6561/2000	0.90
8202/2500	0.86
9842/3000	0.82
11482/3500	0.78

Table 3.1 Altitude Derating Factor

3.1.2 Environmental Requirements for Mechanical Installation

The unit is air-cooled. To protect the unit from overheating, ensure that the ambient temperature does not exceed the maximum temperature stated for the 24-hour average temperature. If the ambient temperature is in the range of 113 °F to 131 °F, derating becomes relevant. If derating for ambient temperature is not taken into account, the service life of the unit is reduced.

3.2 Mechanical Installation

3.2.1 Accessory Bags

Find the following parts included in the accessory bag:

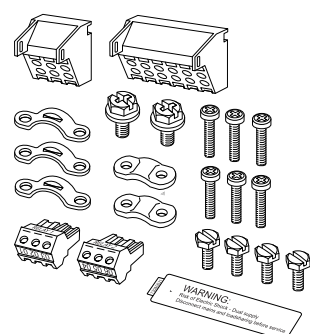

Figure 3.1 Enclosures B1 and B2, IP21/IP55/Type 1/Type 12

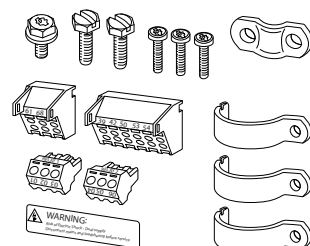

Figure 3.2 Enclosure B3, IP20/Chassis

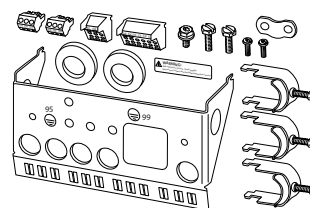

Figure 3.3 Enclosure B4, IP20/Chassis

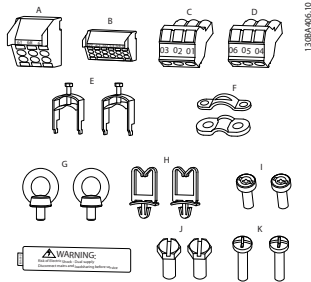

Figure 3.4 Enclosures C1 and C2, IP55/66/Type 1/Type 12

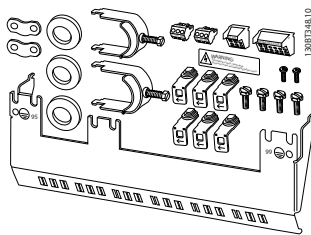

Figure 3.5 Enclosure C3, IP20/Chassis

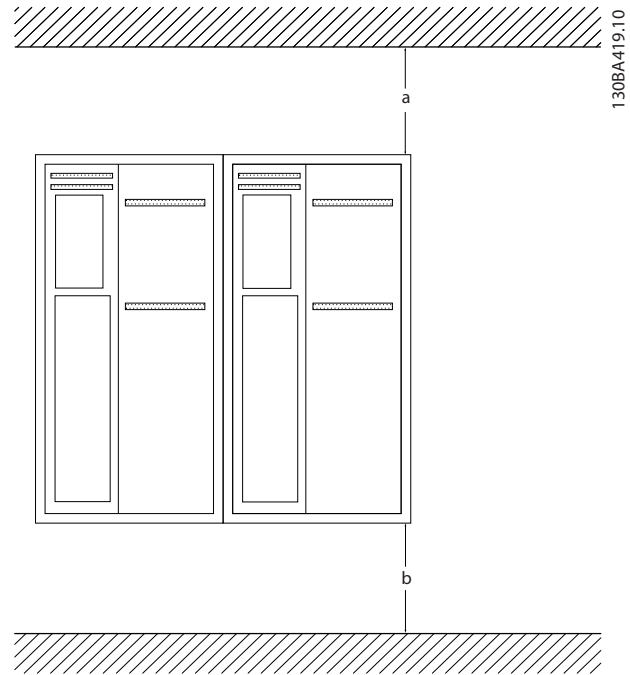

Figure 3.6 Clearance

3.2.2 Mechanical Mounting

1. Drill holes in accordance with the measurements given.
2. Provide screws suitable for the surface on which the compressor drive should be mounted.
3. Retighten all four screws.

The frequency converter IP20 allows side-by-side installation. Because of the need for cooling, there must be a minimum of 7.9 in (200 mm) free air passage above and below the frequency converter.

The back wall must always be solid. All frequency converters are equipped with a back metal plate to guarantee proper heat exchanger ventilation. Never remove this metal sheet.

Frame size	A1*/A2/A3/A4/A5 /B1	B2/B3/B4/C 1/C3	C2/C4
a [Inch/mm]	3.3/100	7.9/200	8.9/225
b [inch/mm]	3.3/100	7.9/200	8.9/225

Table 3.2 Air Passage for Different Frame Sizes

3.2.3 Mechanical Dimensions

IP 20 Chassis	T2 [240 V]	T4 [480 V]	T6 [575 V]
VSH088 [15 kW]	B4	B3	B3
VSH117 [18 kW]	C3	B4	B4
VSH170 [22 kW]	C3	B4	B4
IP 55 NEMA 12			
VSH088 [15 kW]	C1	B1	B1
VSH117 [18 kW]	C1	B2	B2
VSH170 [22 kW]	C1	B2	B2

Table 3.3 Related VSH Numbers

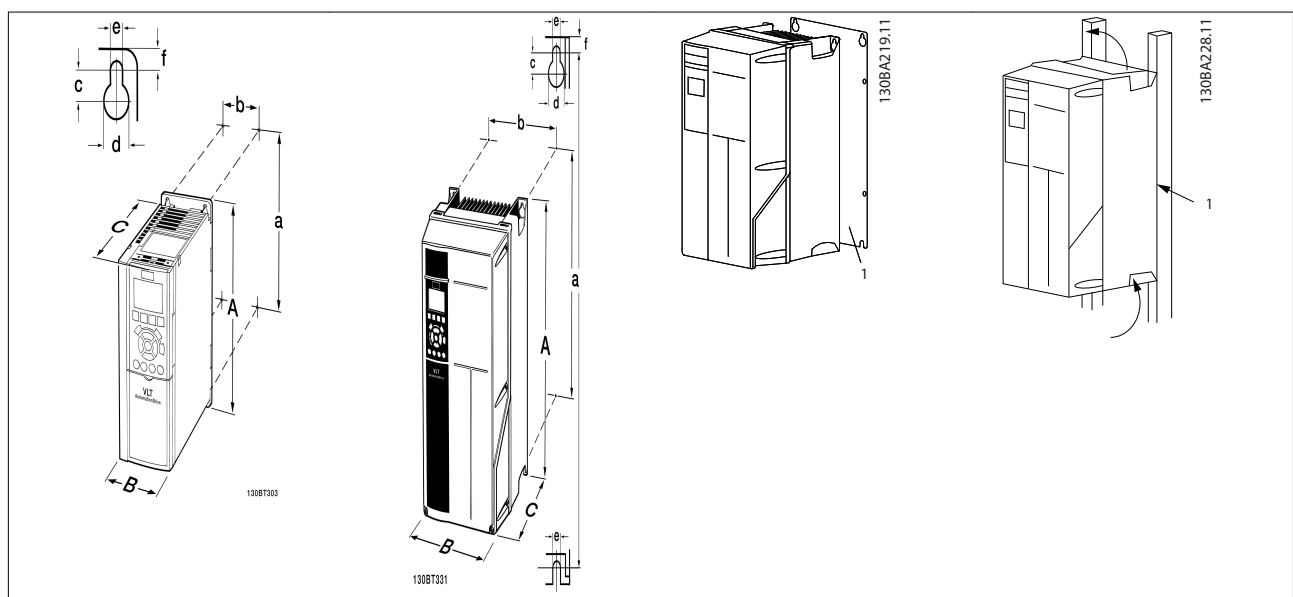

Table 3.4 Dimensional Drawings

		B1	B2	B3	B4	C1	C3
Height [inch/mm]							
Backplate	A	18.90/480	25.59/650	15.71/399	20.47/520	26.77/680	21.65/550
Distance between mounting holes	a	17.87//454	24.57/624	14.96/380	19.49/495	25.51/648	20.51/521
Width [inch/mm]							
Back plate	B	9.53/242	9.53/242	6.50/165	9.06/230	12.13/308	12.13/308
Distance between mounting holes	b	8.28/210	8.28/210	5.51/140	7.87/200	10.71/272	10.63/270
Depth [inch/mm]							
Without option	C	10.24/260	10.24/260	9.80/249	9.53/242	12.21/310	13.11/333
With option	C	10.24/260	10.24/260	10.24/260	9.53/242	12.21/310	13.11/333
Screw holes [inch/mm]							
	c	0.47/12.0	0.47/12.0	0.32		0.49/12.0	
	d	Ø 0.75/19.0	Ø 0.75/19.0	0.47/12.0		Ø 0.75/19.0	
	e	Ø 0.35/9	Ø 0.35/9	0.34/8.8	0.33/8.5	Ø 0.35/9	0.33/8.5
	f	0.35/9	0.35/9	0.31/7.9	0.59/15	0.38/9.8	0.67/17
Other Specifications							
Max. weight [lbs/kg]		50.4/23	59.53/27	26.46/12	51.81/23.5	99.21/45	77.16/35

Table 3.5 Mechanical Dimensions

3.3 Electrical Installation

3.3.1 Cables General

CAUTION

Cables general:

Always comply with national and local regulations on cable cross-sections.

Frame size	200-240 V [kW]	380-500 V [kW]	525-690 V [kW]	Cable for	Tightening torque [Nm]
B1	5.5-7.5	11-15	15	Mains, motor cables	1.8
				Relay	0.5-0.6
				Ground	2-3
B2	11	18.5-22	18.5-22	Mains	4.5
				Motor cables	4.5
				Relay	0.5-0.6
				Ground	2-3
B3	5.5-7.5	11-15	15	Mains, motor cables	1.8
				Relay	0.5-0.6
				Ground	2-3
B4	11-15	18.5-30	18.5-22	Mains, motor cables	4.5
				Relay	0.5-0.6
				Ground	2-3
C3	18.5-22	-	-	Mains, motor cables	10
				Relay	0.5-0.6
				Ground	2-3

Table 3.6 Tightening Torque

3.3.2 Removal of Knockouts for Extra Cables

- Remove cable entry from the frequency converter (avoiding foreign parts in the frequency converter when removing knockouts)
- Support cable entry around the knockout that should be removed
- The knockout can now be removed with a strong mandrel and a hammer
- Remove burrs from the hole
- Mount cable entry on frequency converter

3

3.3.3 Mains Connection for B1, B2 and B3

NOTICE!

Frequency converter sizes differ, but terminal numbers are always the same. Incoming power is always 91, 92, 93 labeled L1, L2, L3.

NOTICE!

For correct cable dimensions see *chapter 8 General Specifications*.

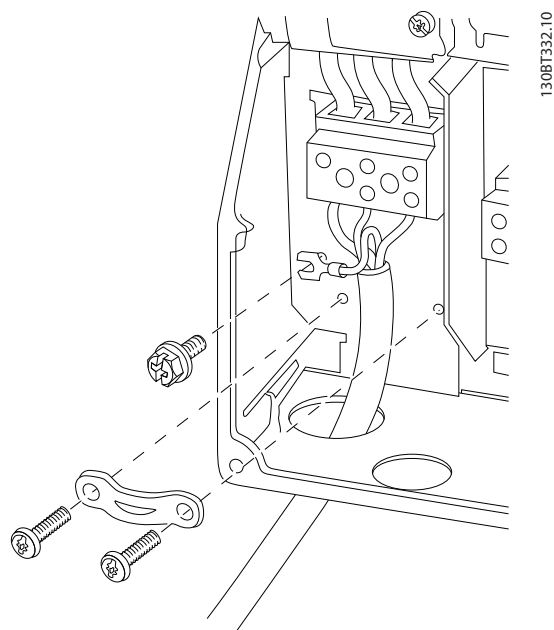

Figure 3.7 How to Connect to Mains and Grounding for B1 and B2

Figure 3.8 How to Connect to Mains and Grounding for B3 without RFI

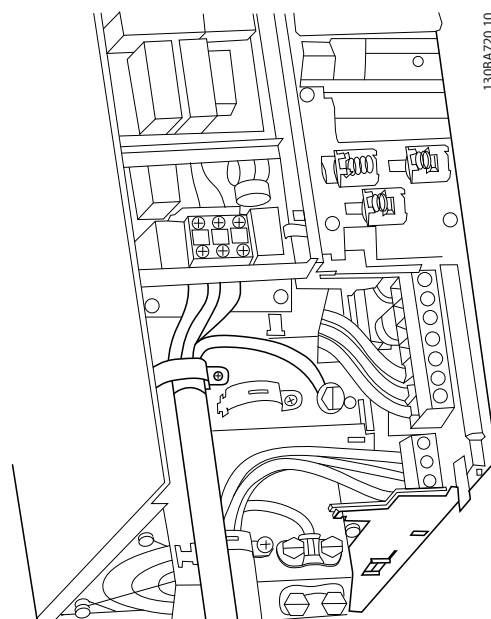
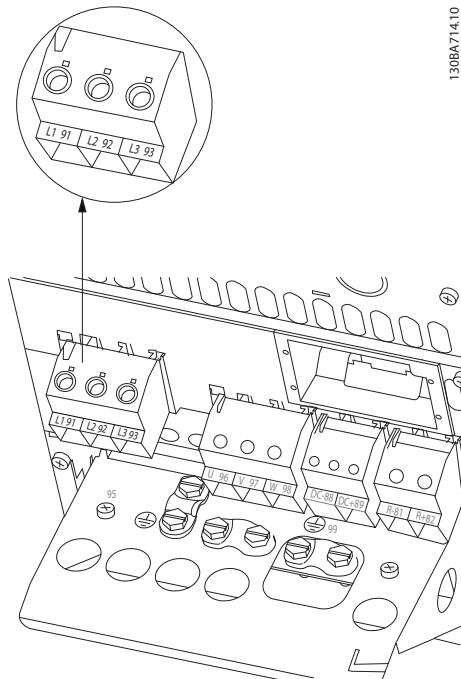

Figure 3.9 How to Connect to Mains and Grounding for B3 with RFI

3.3.4 Mains connection for B4, C1 and C3

NOTICE!

Frequency converter sizes differ but terminal numbers are always the same. Incoming power is always 91, 92, 93 labeled L1, L2, L3.



130BA714.10

Figure 3.10 How to Connect to Mains and Grounding for B4

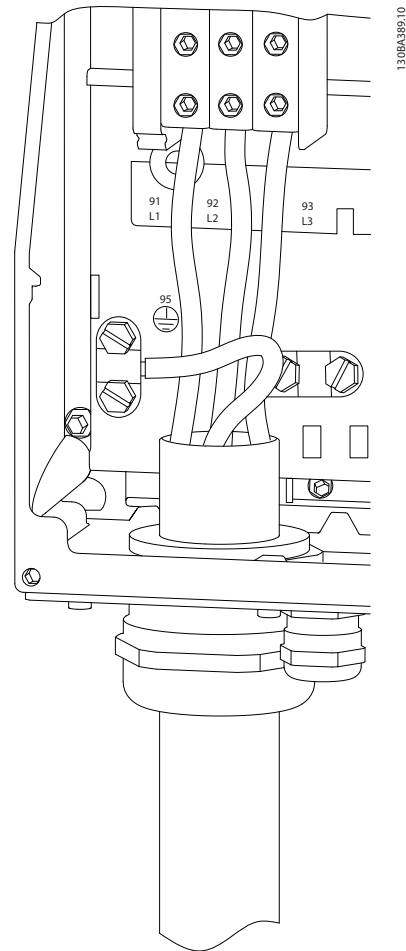

130BA389.10

Figure 3.11 How to Connect to Mains and Grounding for C1 and C2

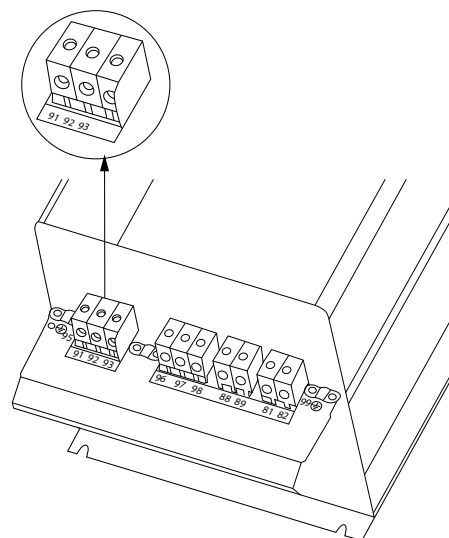

130BA718.10

Figure 3.12 How to Connect C3 to Mains and Grounding

3.3.5 Motor Compressor Connection

NOTICE!

Always wire terminal 96 (U) to T1, 97 (V) to T2, and 98 (W) to T3.

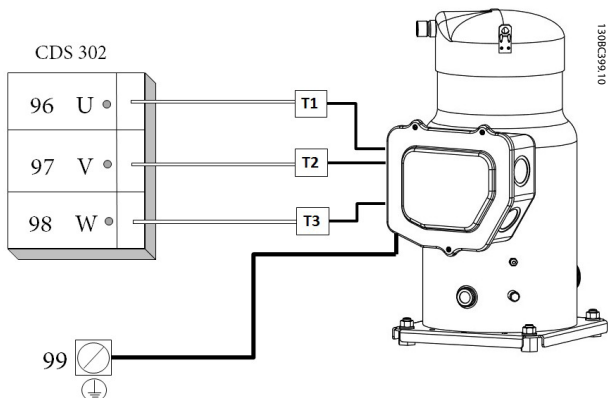

Figure 3.13 Motor/Compressor Wiring

Motor compressor cable must be screened/armored. If an unscreened/unarmored cable is used, some EMC requirements are out of compliance. For more information, see EMC specifications.

1. Fasten decoupling plate to the bottom of the frequency converter with screws and washers from the accessory bag.
2. Attach motor compressor cable to terminals 96 (U), 97 (V), 98 (W).
3. Connect to ground connection (terminal 99) on decoupling plate with screws from the accessory bag.
4. Insert terminals 96 (U), 97 (V), 98 (W) and motor compressor cable to terminals labeled MOTOR.
5. Fasten screened cable to decoupling plate with screws and washers from the accessory bag.
6. Connect U, V, W for motor compressor clockwise.

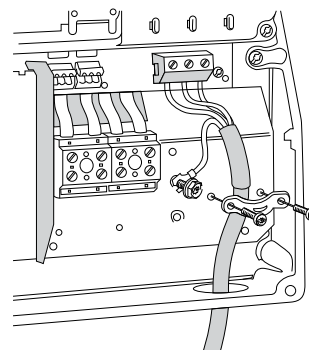

Figure 3.14 How to Connect to Motor Terminals B1/B2

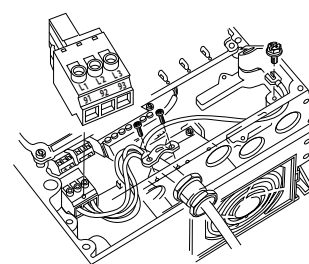

Figure 3.15 How to Connect to Mains and Ground without Mains Disconnect

3.3.6 Motor Compressors Cables

Correct dimensioning of motor compressor cable cross-section and length is described in the application manual.

- Use a screened/armored motor compressor cable to comply with EMC emission specifications
- Keep the motor compressor cable as short as possible to reduce the noise level and leakage currents
- Connect the motor compressor cable screen to both the decoupling plate of the frequency converters and to the metal cabinet of the motor compressor
- Make the screen connections with the largest possible surface area (cable clamp). Use the supplied installation devices in the frequency converter for making the screen connections.

3.3.7 Electrical Installation of Motor Compressor Cables

Screening of cables

Avoid installation with twisted screen ends (pigtailed). They reduce the screening effect at higher frequencies.

Cable length and cross section

The frequency converter has been tested with a given length of cable and a given cross section of that cable. If the cross section is increased, the cable capacitance - and thus the leakage current - may increase, and the cable length must be reduced correspondingly.

Aluminum conductors

Aluminium conductors are not recommended. Terminals accept aluminium conductors, but clean the conductor surface and remove and seal the oxidation by neutral acid-free Vaseline grease before the conductor is connected. Furthermore, the terminal screw must be retightened after two days due to the softness of the aluminium. It is crucial to keep the connection a gas tight joint, otherwise the aluminium surface oxidizes again.

3.3.8 Compressor Motor Protection

The frequency converter fully provides electrical compressor motor protection.

- The frequency converter makes through an electronic current measurement anti-overload and lock-rotor compressor motor protection (see description in the application manual).
- The frequency converter is protected against short circuits on compressor terminals T1, T2, T3
- If a mains phase is missing, the frequency converter trips or issues a warning (depending on the load)
- If a compressor motor phase is missing, the frequency converter trips
- The frequency converter is protected against ground faults on compressor motor terminals T1, T2, T3

3.3.9 Access to Control Terminals

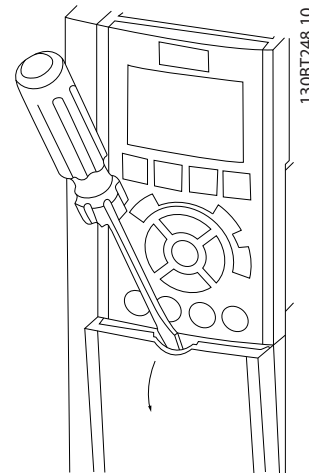

Figure 3.16 B3, B4 and C3 Enclosures

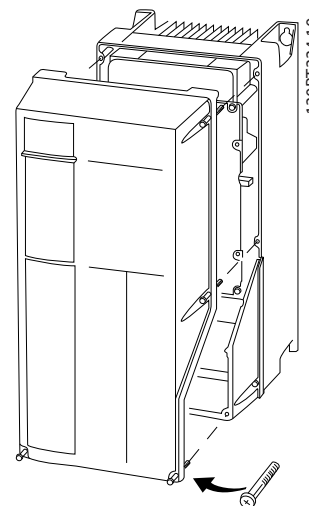

Figure 3.17 C1, B1 and B2 Enclosures

Control terminals are located beneath the LCP. The inside of the removable cover shows the terminals.

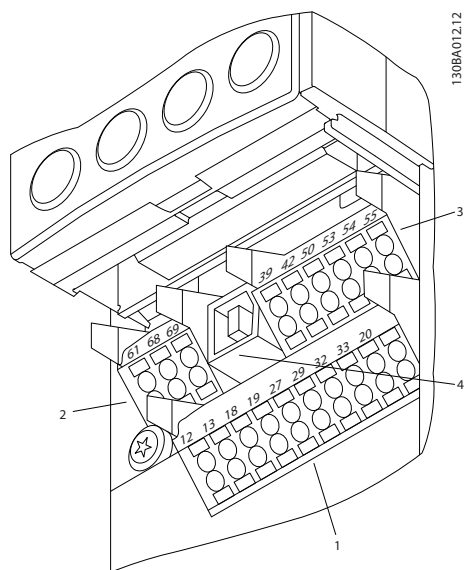

Figure 3.18 Control Terminals

1. 10 pole plug digital I/O
2. 3 pole plug RS-485 Bus
3. 6 pole analog I/O
4. USB Connection

To mount the cable to the terminal:

1. Strip isolation of 9-10 mm.
2. Insert a screwdriver in the square hole.
3. Insert the cable in the adjacent circular hole.
4. Remove the screwdriver. The cable is now mounted to the terminal.

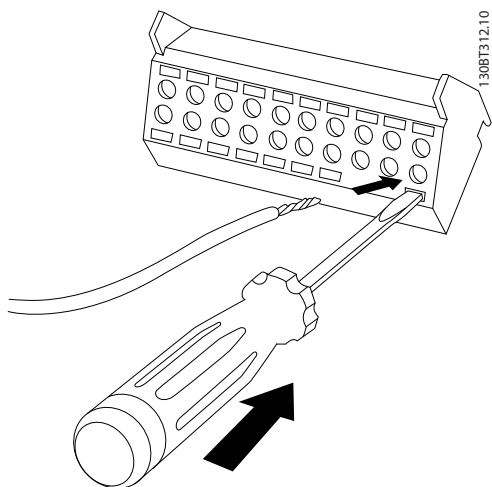

Figure 3.19 Mounting the Cable

To remove the cable from the terminal:

1. Insert a screwdriver in the square hole.
2. Pull the cable.

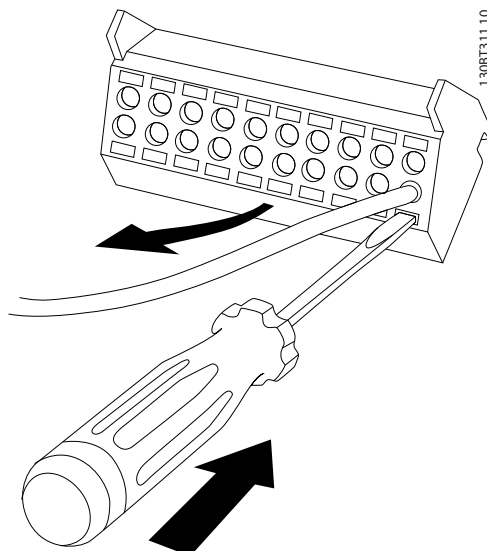

Figure 3.20 Removing the Cable

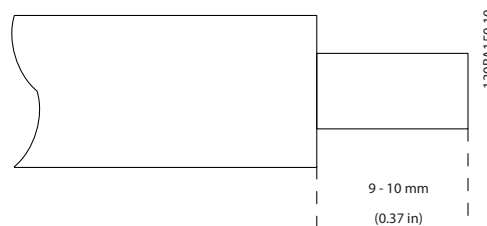

Figure 3.21 Stripping the Cable

3.3.10 Basic Wiring Example

1. Mount terminals from the accessory bag to the front of the frequency converter.

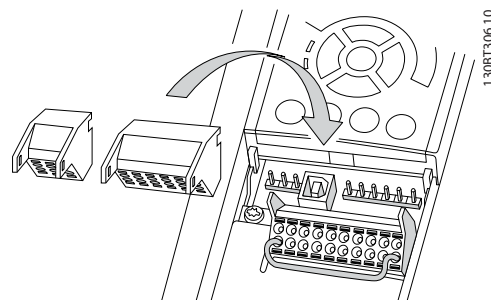

Figure 3.22 Mounting the Terminals

2. Connect terminals 18, 27 and 37 to +24 V (terminal 12/13)

Default settings:

18 = start

27 = coast inverse

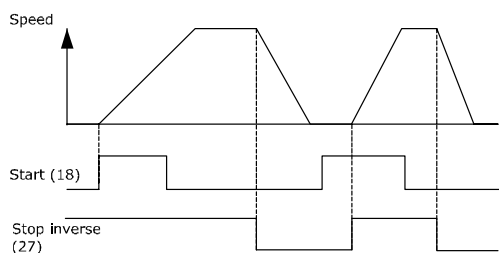
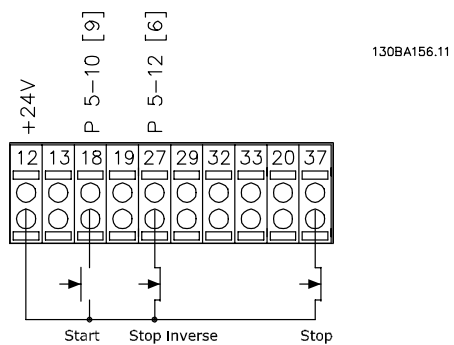

Figure 3.23 Example of Basic Wiring

3.3.11 Electrical Installation, Control Cables

Use terminal 37 as input for safe stop. In rare cases, control cables more than 100 m (330 ft) and analog signals result in 50/60 Hz ground loops due to noise from mains supply cables. If this situation occurs, break the screen or insert a 100 nF capacitor between screen and chassis. Connect the digital and analog inputs and outputs separately to the frequency converter common inputs (terminal 20, 55, 39) to avoid ground currents affecting the system.

3

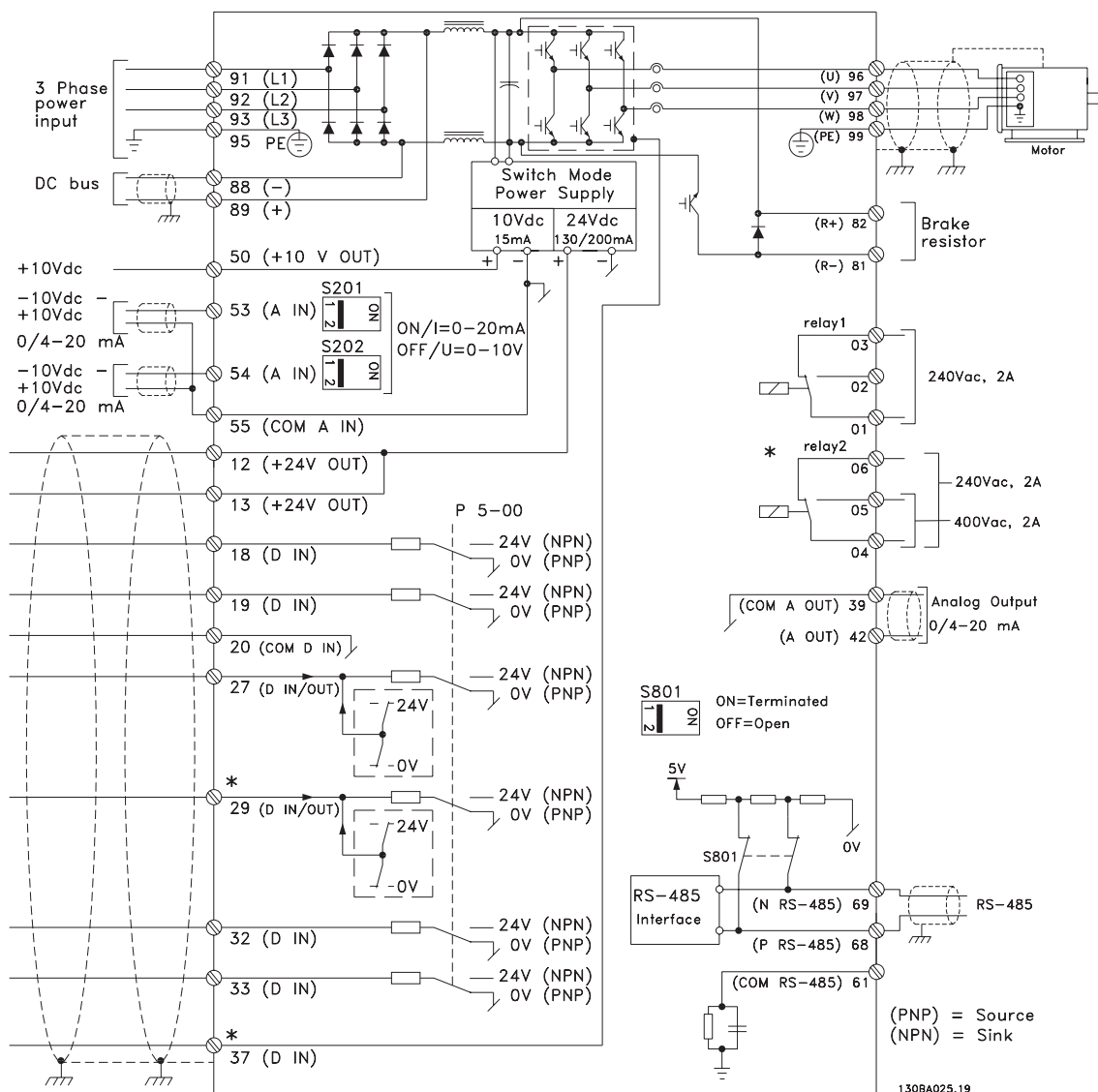

Figure 3.24 Electrical Diagram - Control Cables

Control cables must be shielded/armored. To connect the screen to the frequency converter decoupling plate for control cables, use a clamp from the accessory bag.

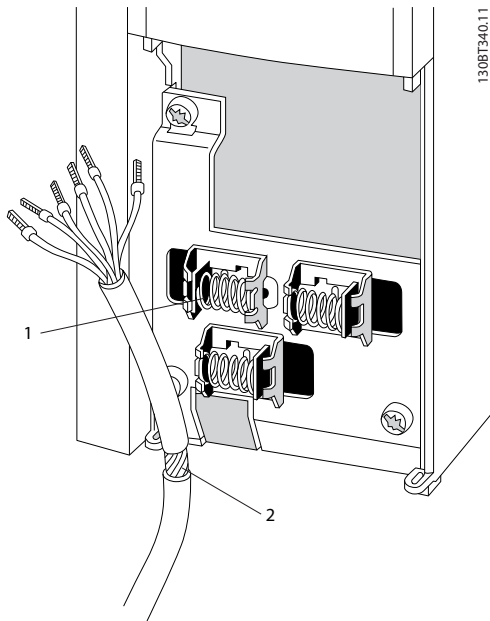

Figure 3.25 Control Cable Connection

Figure 3.26 indicates how correct grounding is carried out and what to do if in doubt.

a. Correct grounding

Control cables and cables for serial communication must be fitted with cable clamps at both ends to ensure the best possible electrical contact.

b. Wrong grounding

Do not use twisted cable ends (pigtailed). They increase the screen impedance at high frequencies.

c. Protection concerning ground potential between PLC (Program Logic Controller) and frequency converter

If the ground potential between the frequency converter and the PLC (etc.) is different, electric noise may occur that disturbs the entire system. Solve this problem by fitting an equalizing cable, next to the control cable. Minimum cable cross-section: 16 mm².

d. For 50/60 Hz ground loops

If long control cables are used, 50/60 Hz ground loops may occur. Solve this problem by connecting one end of the screen to ground via a 100 nF capacitor (keeping leads short).

e. Cables for serial communication

Eliminate low-frequency noise currents between two frequency converters by connecting one end of the screen to terminal 61. This terminal is connected to ground via an internal RC link. To reduce the differential mode interference between the conductors, use twisted-pair cables.

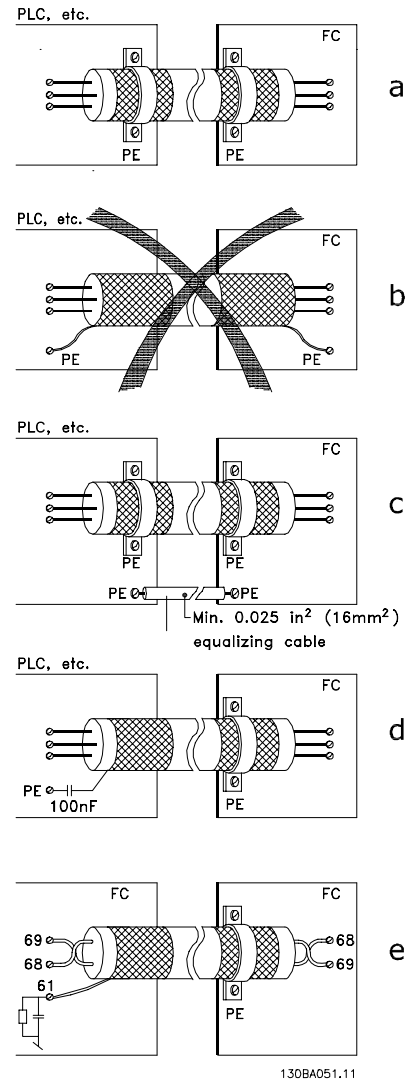

Figure 3.26 Examples of ground Wiring

3.3.12 Electrical Installation - EMC Protection

The following is a guideline to good engineering practice when installing frequency converters. To comply with EN 61800-3 First environment, follow these guidelines. If the installation is in EN 61800-3 Second environment, i.e. industrial networks, or in an installation with its own transformer, deviation from these guidelines is allowed, but not recommended.

Good engineering practice to ensure EMC-correct electrical installation

- Use only braided screened/armored motor compressor cables and braided screened/armored control cables. The screen should provide a minimum coverage of 80%. The screen material must be metal, not limited to but typically copper, aluminum, steel, or lead. There are no special requirements for the mains cable.
- Installations using rigid metal conduits are not required to use screened cable, but the motor compressor cable must be installed in conduit separate from the control and mains cables. Full connection of the conduit from the frequency converter to the motor compressor is required. The EMC performance of flexible conduits varies a lot and information from the manufacturer must be obtained.
- Connect the screen/armor/conduit to ground at both ends for motor compressor cables as well as for control cables. In some cases, it is not possible to connect the screen in both ends. If so, connect the screen at the frequency converter. See also *chapter 3.3.11 Electrical Installation, Control Cables*.
- Avoid terminating the screen/armor with twisted ends (pigtailed). It increases the high frequency impedance of the screen, which reduces its effectiveness at high frequencies. Use low impedance cable clamps or EMC cable glands instead.
- Avoid using unscreened/unarmored motor compressor or control cables inside cabinets housing the frequency converter(s).

Leave the screen as close to the connectors as possible.

Figure 3.27 shows an example of an EMC-correct electrical installation of an IP20 frequency converter. The frequency converter is fitted in an installation cabinet with an output contactor and connected to a PLC, which is installed in a separate cabinet. Other ways of doing the installation may have just as good an EMC performance, provided the above guide lines to engineering practice are followed. Installing without following the guideline, and using unscreened cables and control wires do not comply with all emission requirements, although the immunity requirements are fulfilled.

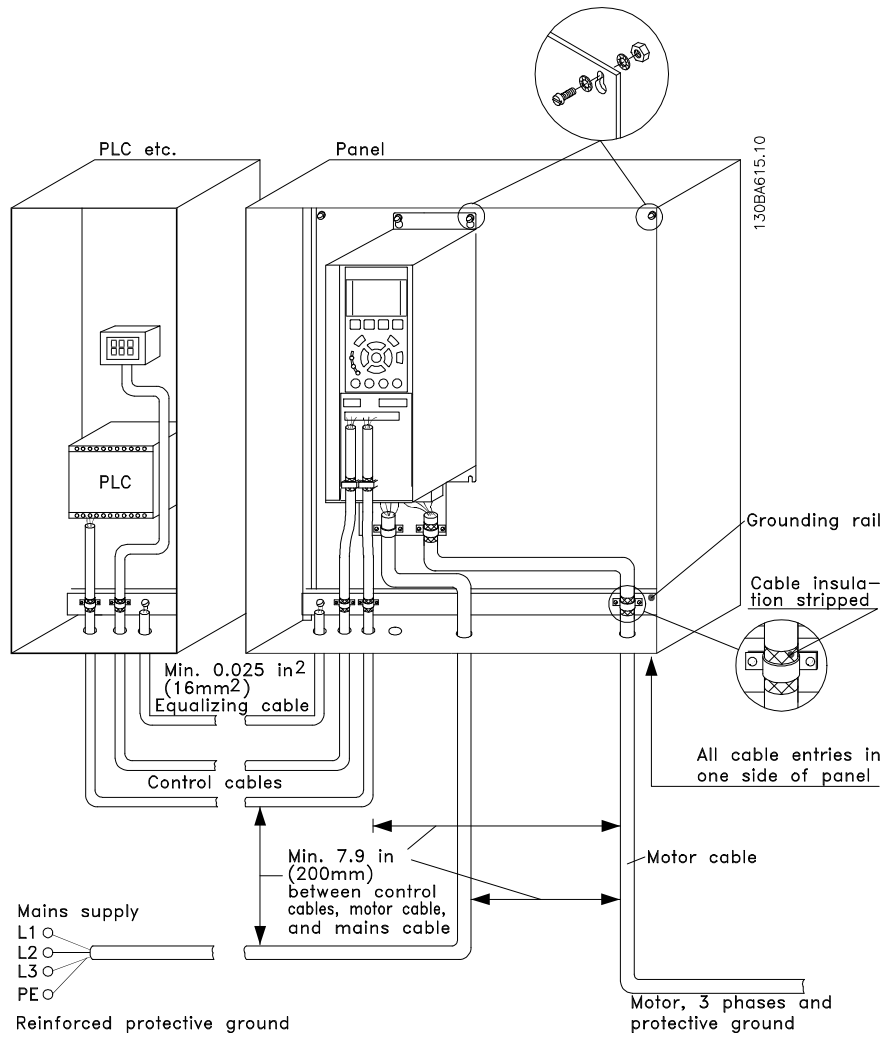

Figure 3.27 EMC Correct Installation of an IP20 Frequency Converter

3.3.13 Safety Ground Connection

The frequency converter has a high leakage current and must be grounded appropriately for safety reasons according to EN 50178. The ground leakage current from the frequency converter exceeds 3.5 mA. To ensure a good mechanical connection from the ground cable to the ground connection (terminal 95), the cable cross-section must be at least 10 mm² or 2 rated ground wires terminated separately.

3.3.14 Basic Examples of Control Connections

Controls using an external controller with 0-10 V signal. It is not necessary to change any parameters, as this is the default value.

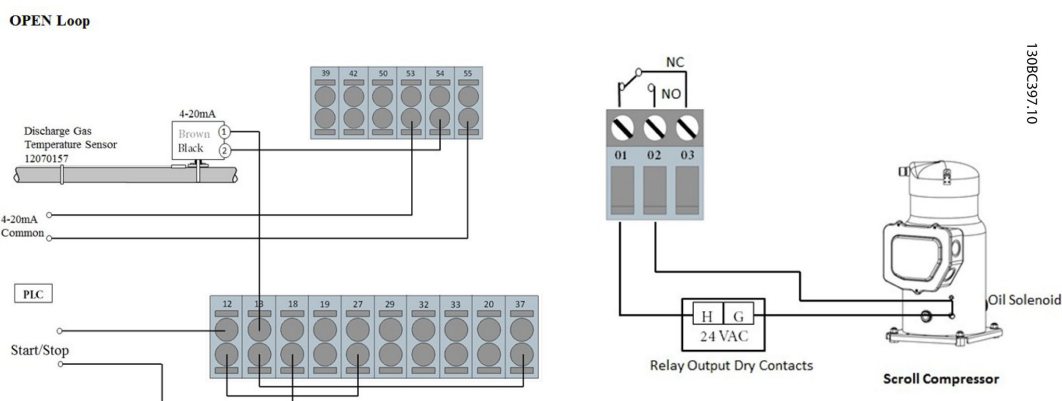

Figure 3.28 Example of External Controller with 0-10 V Signal

Controls using an external controller with 4-20 mA signal. Change switch 53 from U to I. It is not necessary to change any parameters, as this is the default value.

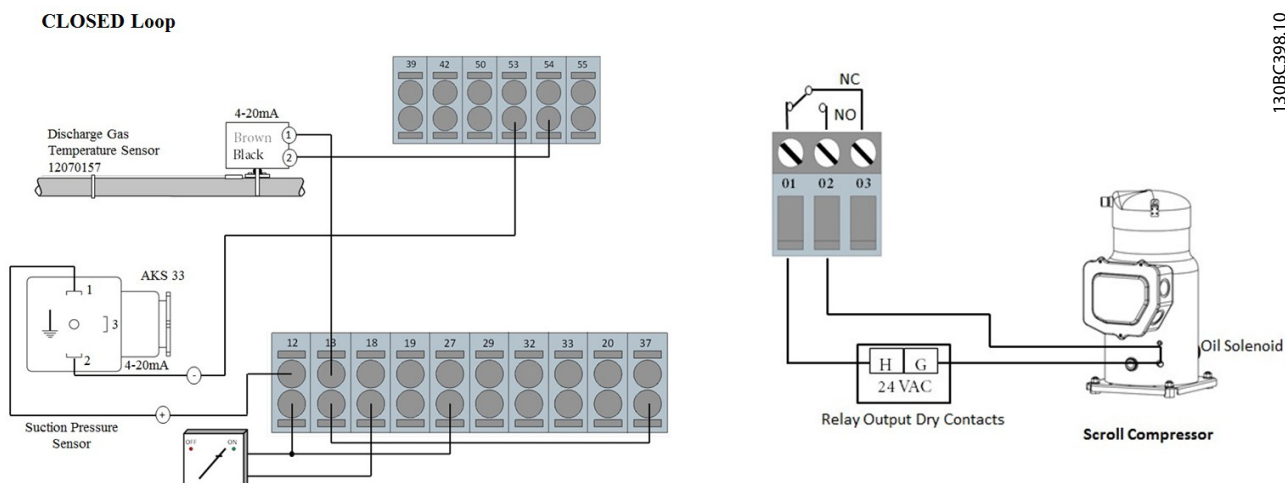

Figure 3.29 Example of External Controller with 4-20 mA Signal

3.3.15 High-voltage Test

Carry out a high-voltage test by short-circuiting terminals U, V, W, L1, L2 and L3. Energize by max. 2.15 kV DC for 1 s between this short circuit and the chassis.

NOTICE!

When running high-voltage tests of the entire installation, frequency converter and compressor electrical motor compressor test can be conducted together.

⚠ WARNING

When conducting a high-voltage test, make sure that the system is not under vacuum: a vacuum may cause electrical motor compressor failure.

⚠ WARNING

Never apply the high-voltage test to the control circuit.

3.4 Fuses and Circuit Breakers

3.4.1 Fuses

NOTICE!

To ensure compliance with IEC 60364 for CE or NEC 2009 for UL, use fuses and/or circuit breakers on the supply side of the unit for protection of electrical components within the frequency converter.

⚠ WARNING

Personnel and property must be protected against the consequence of component break-down internally in the frequency converter.

Branch Circuit Protection

To protect the installation against electrical and fire hazard, all branch circuits in an installation, switch gear, machines etc., must be protected against short circuit and over-current according to national/international regulations.

NOTICE!

The recommendations given do not provide UL branch circuit protection.

Danfoss recommends using the fuses/circuit breakers listed in the following tables to protect service personnel and property in case of component break-down in the frequency converter.

3.4.2 Recommendations

⚠ WARNING

In case of malfunction, ignoring recommended fuse types may result in personnel risk and damage to the frequency converter and other equipment.

The following tables list the recommended rated current. Recommended fuses are of the type gG for small to medium power sizes. For larger powers, aR fuses are recommended. For circuit breakers, Moeller types have been tested to have a recommendation. Other circuit breakers may be used if they limit the energy into the frequency converter to a level equal to or lower than the Moeller types.

For further information, see Application Note *Fuses and Circuit Breakers, MN90T*

3.4.3 CE Compliance

Fuses or circuit breakers are mandatory to comply with IEC 60364. Danfoss recommends using a selection of the following.

The fuses below are suitable for use on a circuit capable of delivering 100,000 Arms (symmetrical), 240 V, 480 V, 500 V, or 600 V depending on the unit's voltage rating. With the proper fusing, the frequency converter short circuit current rating (SCCR) is 100,000 Arms.

3.4.4 Fuse Specifications

Enclosure Size	Power [kW]	Recommended fuse size	Recommended Max. fuse	Recommended circuit breaker	Max trip level [A]
				Moeller	
B1	5.5-7.5	gG-25 (5.5) gG-32 (7.5)	gG-80	PKZM4-63	63
B2	11	gG-50	gG-100	NZMB1-A100	100
B3	5.5	gG-25	gG-63	PKZM4-50	50
B4	7.5-15	gG-32 (7.5) gG-50 (11) gG-63 (15)	gG-125	NZMB1-A100	100
C1	15-22	gG-63 (15) gG-80 (18.5) gG-100 (22)	gG-160 (15-18.5) aR-160 (22)	NZMB2-A200	160
C2	30-37	aR-160 (30) aR-200 (37)	aR-200 (30) aR-250 (37)	NZMB2-A250	250
C3	18.5-22	gG-80 (18.5) aR-125 (22)	gG-150 (18.5) aR-160 (22)	NZMB2-A200	150
C4	30-37	aR-160 (30) aR-200 (37)	aR-200 (30) aR-250 (37)	NZMB2-A250	250

Table 3.7 200-240 V, Frame Sizes B and C

Enclosure Size	Power [kW]	Recommended fuse size	Recommended Max. fuse	Recommended circuit breaker	Max trip level [A]
				Moeller	
B1	11-15	gG-40	gG-80	PKZM4-63	63
B2	18.5-22	gG-50 (18.5) gG-63 (22)	gG-100	NZMB1-A100	100
B3	11-15	gG-40	gG-63	PKZM4-50	50
B4	18.5-30	gG-50 (18.5) gG-63 (22) gG-80 (30)	gG-125	NZMB1-A100	100
C1	30-45	gG-80 (30) gG-100 (37) gG-160 (45)	gG-160	NZMB2-A200	160
C2	55-75	aR-200 (55) aR-250 (75)	aR-250	NZMB2-A250	250
C3	37-45	gG-100 (37) gG-160 (45)	gG-150 (37) gG-160 (45)	NZMB2-A200	150
C4	55-75	aR-200 (55) aR-250 (75)	aR-250	NZMB2-A250	250

Table 3.8 380-500 V, Frame Sizes B and C

Enclosure Size	Power [kW]	Recommended fuse size	Recommended Max. fuse	Recommended circuit breaker	Max trip level [A]
				Moeller	
B1	11-18	gG-25 (11) gG-32 (15) gG-40 (18.5)	gG-80	PKZM4-63	63
B2	22-30	gG-50 (22) gG-63 (30)	gG-100	NZMB1-A100	100
B3	11-15	gG-25 (11) gG-32 (15)	gG-63	PKZM4-50	50
B4	18.5-30	gG-40 (18.5) gG-50 (22) gG-63 (30)	gG-125	NZMB1-A100	100
C1	37-55	gG-63 (37) gG-100 (45) aR-160 (55)	gG-160 (37-45) aR-250 (55)	NZMB2-A200	160
C2	75	aR-200 (75)	aR-250	NZMB2-A250	250
C3	37-45	gG-63 (37) gG-100 (45)	gG-150	NZMB2-A200	150
C4	55-75	aR-160 (55) aR-200 (75)	aR-250	NZMB2-A250	250

Table 3.9 525-600 V, Frame Sizes B and C
UL Compliance

Fuses or circuit breakers are mandatory to comply with NEC 2009. Danfoss recommends using a selection of the following.

The fuses below are suitable for use on a circuit capable of delivering 100,000 Arms (symmetrical), 240 V, 480 V, 500 V, or 600 V depending on the unit's voltage rating. With the proper fusing, the frequency converter's Short Circuit Current Rating (SCCR) is 100,000 Arms.

Power [kW]	Recommended max. fuse					
	Bussmann	Bussmann	Bussmann	Bussmann	Bussmann	Bussmann
11	KTN-R-80	JKS-80	JJN-80	-	-	-
15-18.5	KTN-R-125	JKS-125	JJN-125	-	-	-
22	KTN-R-150	JKS-150	JJN-150	-	-	-
30	KTN-R-200	JKS-200	JJN-200	-	-	-
37	KTN-R-250	JKS-250	JJN-250	-	-	-

Table 3.10 200-240 V, Frame Sizes B and C

Power[kW]	Recommended max. fuse			
	SIBA	Littel fuse	Ferraz-Shawmut	Ferraz-Shawmut
	Type RK1	Type RK1	Type CC	Type RK1
11	5014006-080	KLN-R-80	-	A2K-80-R
15-18.5	2028220-125	KLN-R-125	-	A2K-125-R
22	2028220-150	KLN-R-150	-	A2K-150-R
30	2028220-200	KLN-R-200	-	A2K-200-R
37	2028220-250	KLN-R-250	-	A2K-250-R

Table 3.11 200-240 V, Frame Sizes B and C

Power[kW]	Recommended max. fuse			
	Bussmann	Littel fuse	Ferraz-Shawmut	Ferraz-Shawmut
	Type JFHR2 ¹⁾	JFHR2	JFHR2 ²⁾	J
11	FWX-80	-	-	HSJ-80
15-18.5	FWX-125	-	-	HSJ-125
22	FWX-150	L25S-150	A25X-150	HSJ-150
30	FWX-200	L25S-200	A25X-200	HSJ-200
37	FWX-250	L25S-250	A25X-250	HSJ-250

Table 3.12 200-240 V, Frame Sizes B and C

- ¹⁾ FWH-fuses from Bussmann may substitute FWX for 240 V frequency converters.
²⁾ A50X fuses from FERRAZ SHAWMUT may substitute A25X for 240 V frequency converters.

Power [kW]	Recommended max. fuse					
	Bussmann	Bussmann	Bussmann	Bussmann	Bussmann	Bussmann
	Type RK1	Type J	Type T	Type CC	Type CC	Type CC
11	KTS-R-40	JKS-40	JJS-40	-	-	-
15	KTS-R-50	JKS-50	JJS-50	-	-	-
18	KTS-R-60	JKS-60	JJS-60	-	-	-
22	KTS-R-80	JKS-80	JJS-80	-	-	-
30	KTS-R-100	JKS-100	JJS-100	-	-	-
37	KTS-R-125	JKS-125	JJS-125	-	-	-
45	KTS-R-150	JKS-150	JJS-150	-	-	-
55	KTS-R-200	JKS-200	JJS-200	-	-	-
75	KTS-R-250	JKS-250	JJS-250	-	-	-

Table 3.13 380-500 V, Frame Sizes B and C

Power [kW]	Recommended max. fuse			
	SIBA	Littel fuse	Ferraz-Shawmut	Ferraz-Shawmut
	Type RK1	Type RK1	Type CC	Type RK1
11	5014006-040	KLS-R-40	-	A6K-40-R
15	5014006-050	KLS-R-50	-	A6K-50-R
18	5014006-063	KLS-R-60	-	A6K-60-R
22	2028220-100	KLS-R-80	-	A6K-80-R
30	2028220-125	KLS-R-100	-	A6K-100-R
37	2028220-125	KLS-R-125	-	A6K-125-R
45	2028220-160	KLS-R-150	-	A6K-150-R
55	2028220-200	KLS-R-200	-	A6K-200-R
75	2028220-250	KLS-R-250	-	A6K-250-R

Table 3.14 380-500 V, Frame Sizes B and C

Power [kW]	Recommended max. fuse			
	Bussmann	Ferraz-Shawmut	Ferraz-Shawmut	Littel fuse
	JFHR2	J	JFHR2 ¹⁾	JFHR2
11	FWH-40	HSJ-40	-	-
15	FWH-50	HSJ-50	-	-
18	FWH-60	HSJ-60	-	-
22	FWH-80	HSJ-80	-	-
30	FWH-100	HSJ-100	-	-
37	FWH-125	HSJ-125	-	-
45	FWH-150	HSJ-150	-	-
55	FWH-200	HSJ-200	A50-P-225	L50-S-225
75	FWH-250	HSJ-250	A50-P-250	L50-S-250

Table 3.15 380-500 V, Frame Sizes B and C

¹⁾ Ferraz-Shawmut A50QS fuses may substitute for A50P fuses.

Power [kW]	Recommended max. fuse					
	Bussmann	Bussmann	Bussmann	Bussmann	Bussmann	Bussmann
	Type RK1	Type J	Type T	Type CC	Type CC	Type CC
11	KTS-R-35	JKS-35	JJS-35	-	-	-
15	KTS-R-45	JKS-45	JJS-45	-	-	-
18	KTS-R-50	JKS-50	JJS-50	-	-	-
22	KTS-R-60	JKS-60	JJS-60	-	-	-
30	KTS-R-80	JKS-80	JJS-80	-	-	-
37	KTS-R-100	JKS-100	JJS-100	-	-	-
45	KTS-R-125	JKS-125	JJS-125	-	-	-
55	KTS-R-150	JKS-150	JJS-150	-	-	-
75	KTS-R-175	JKS-175	JJS-175	-	-	-

Table 3.16 525-600 V, Frame Sizes B and C

Power [kW]	Recommended max. fuse			
	SIBA	Littel fuse	Ferraz-Shawmut	Ferraz-Shawmut
	Type RK1	Type RK1	Type RK1	J
11	5014006-040	KLS-R-035	A6K-35-R	HSJ-35
15	5014006-050	KLS-R-045	A6K-45-R	HSJ-45
18	5014006-050	KLS-R-050	A6K-50-R	HSJ-50
22	5014006-063	KLS-R-060	A6K-60-R	HSJ-60
30	5014006-080	KLS-R-075	A6K-80-R	HSJ-80
37	5014006-100	KLS-R-100	A6K-100-R	HSJ-100
45	2028220-125	KLS-R-125	A6K-125-R	HSJ-125
55	2028220-150	KLS-R-150	A6K-150-R	HSJ-150
75	2028220-200	KLS-R-175	A6K-175-R	HSJ-175

Table 3.17 525-600 V, Frame Sizes B and C

¹⁾ 170M fuses shown from Bussmann use the -/80 visual indicator. -TN/80 Type T, -/110 or TN/110 Type T indicator fuses of the same size and amperage may be substituted.

3.5 Application Example

3.5.1 BASIC Cascade/Pack Controller

3

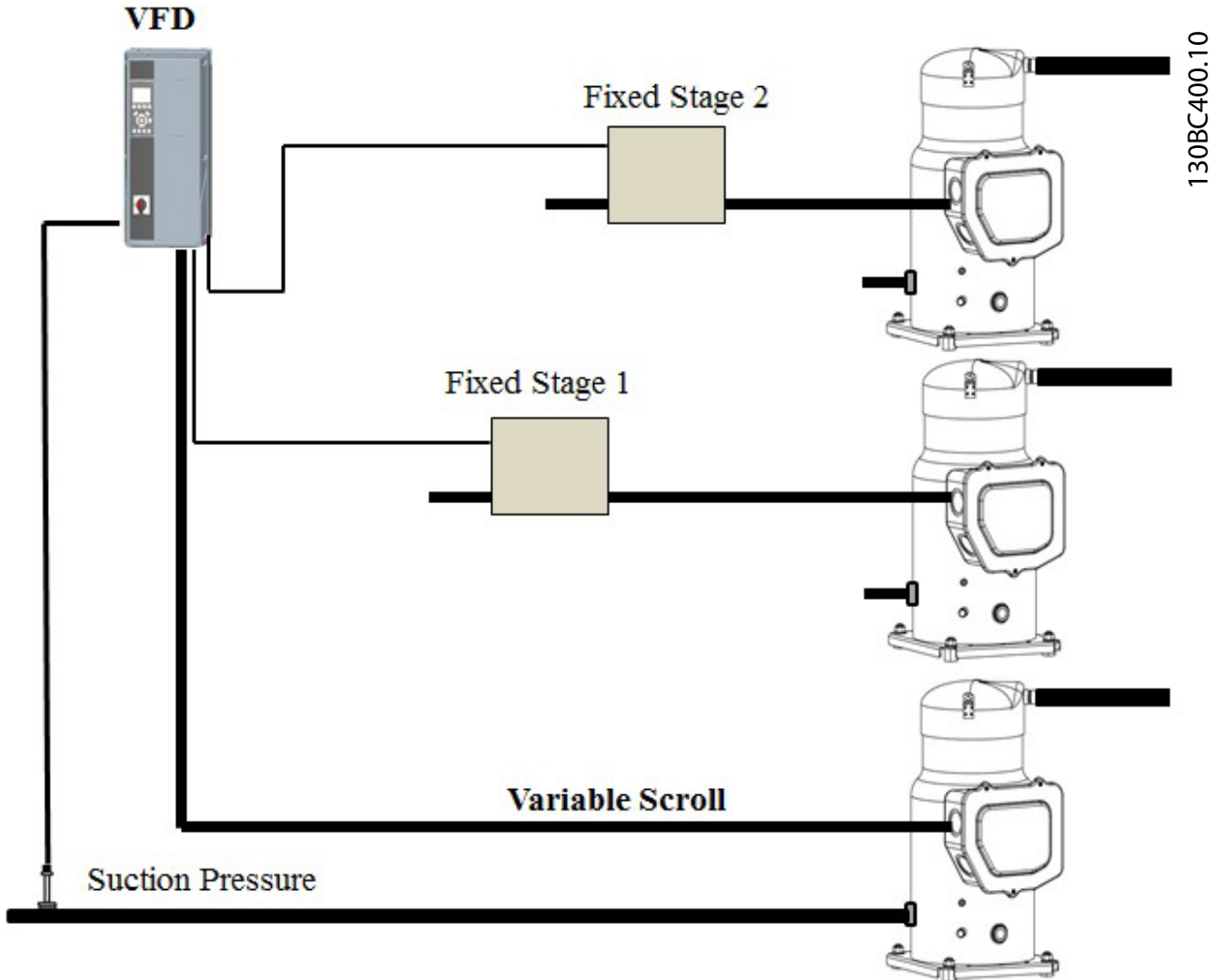

Figure 3.30 Example of BASIC Cascade/Pack Controller

The BASIC Cascade/Pack Controller is used for up to 3 compressors to control up to two on/off compressors together with one variable speed compressor. The capacity control is typically based on suction pressure feedback, but it could also be e.g. a cold room temperature.

Fixed Lead Compressor

The BASIC Pack Controller allows the frequency converter to control up to 3 compressors using the frequency converter's two built-in relays. The variable compressor (lead) is connected directly to the frequency converter, while 2 built-in relays control the other 2 compressors.

NOTICE!

Only one fixed speed compressor can be controlled with the built-in relays. To control two fixed compressors, an extra relay is needed via the MCB 105 Relay Option.

Bandwidth Management

In pack control systems, to avoid frequent switching of fixed speed compressors, the desired system load is kept within a bandwidth rather than at a constant level. The Staging Bandwidth provides the required bandwidth for operation. When a large and quick change in system load occurs, the Override Bandwidth overrides the Staging Bandwidth to prevent immediate response to a short duration load change. An Override Bandwidth Timer can be programmed to prevent staging until the system load has stabilised and normal control established.

When the Pack Controller is enabled and running normally, and the frequency converter issues a trip alarm, staging and destaging fixed speed compressors maintain the system head pressure. To prevent frequent staging and destaging and minimise load fluctuations, a wider Fixed Speed Bandwidth is used instead of the Staging bandwidth.

3.5.2 System Status and Operation

When the pack controller is enabled, the operation status for each compressor and the pack controller is displayed in the LCP. Information displayed includes:

- Compressor Status, is a readout of the status for the relays assigned to each compressor. The display shows compressors that are disabled, off,

running on the frequency converter or running on the mains

- Pack Status, is a readout of the status for the Pack Controller. The display shows that the Pack Controller is disabled, all compressors are off, and emergency has stopped all compressors, all compressors are running, fixed speed compressors are being staged/destaged.
- If a no load need occurs, then destaging ensures that all fixed speed compressors are stopped individually followed by the variable speed compressor.

3.5.3 Pack Compressor Wiring Diagram

The wiring diagram shows an example with the built-in BASIC Cascade Controller with one variable speed compressor (lead) and two fixed speed compressors, a 4-20 mA transmitter and System Safety Interlock.

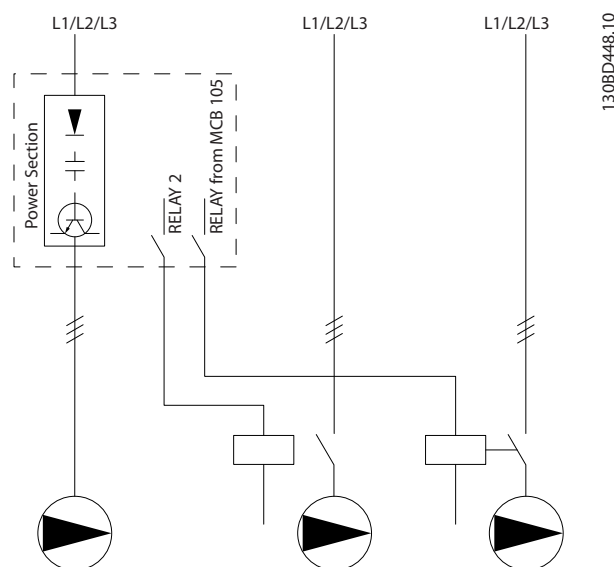

Figure 3.31 Example with Built-in BASIC Cascade Controller

3

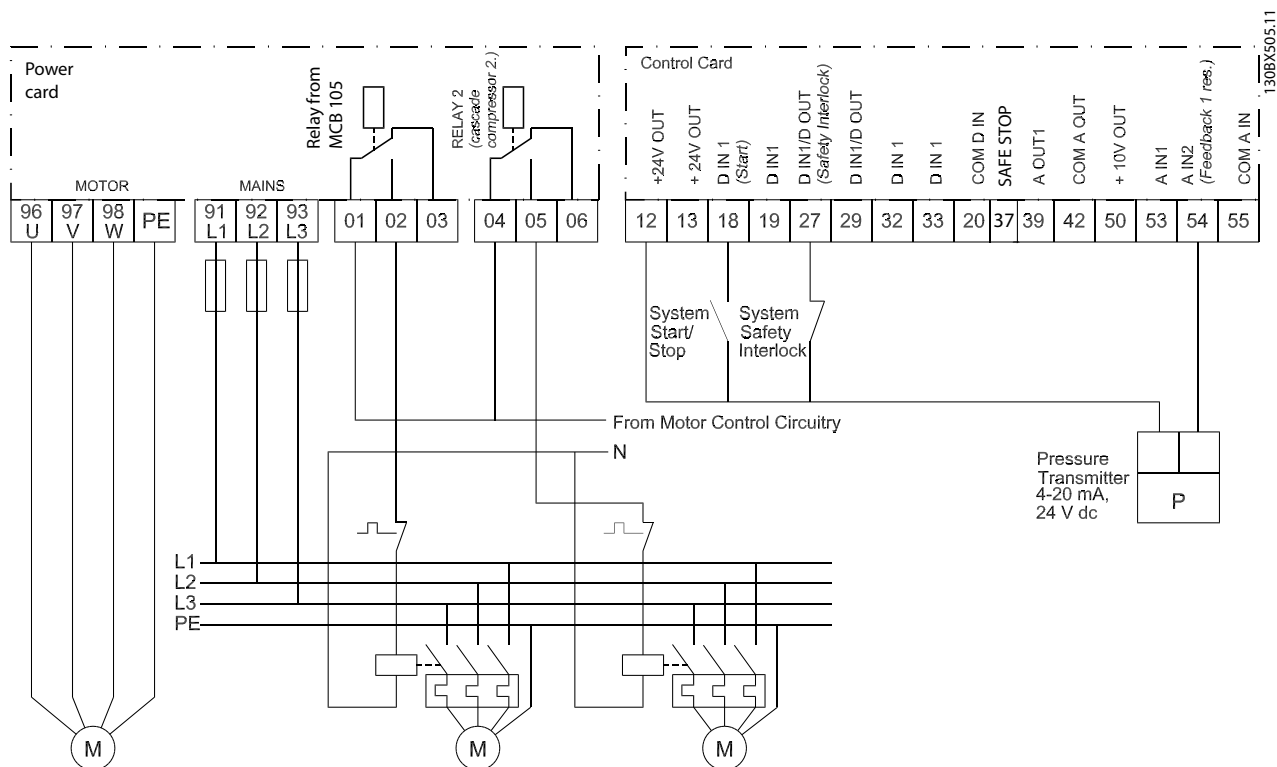

Figure 3.32 Example with Built-in BASIC Cascade Controller

4 Quick Set-up

4.1 Quick Set-up

4.1.1 Basic Programming Procedures

The following describes the basic procedure for running the frequency converter.

CAUTION

When the connections are made, the compressor starts automatically.

1. Connect the power supply to the terminals (L1, L2 and L3) of the frequency converter as shown in *chapter 3.3.4 Mains connection for B4, C1 and C3*.
2. Connect motor cable between the frequency converter (U, V & W) and Compressor (clockwise on terminal), see *chapter 3.3.5 Motor Compressor Connection*. (The connectors utilized in these first 2 steps are provided in the accessory bag which accompanies the frequency converter).
3. Press [Quick Menu] and go to quick setup. Ensure that the correct compressor model is selected in *parameter 1-13 Compressor Selection*.
4. Connect terminal 12 with terminal 18 (start signal), terminal 12 with terminal 27 (inverse coast signal) and terminal 12 with terminal 37* (safe stop inverse signal).

*See *chapter 3.3.10 Basic Wiring Example* and *chapter 2.2.1 Terminal 37 Safe Torque Off Function*.

CAUTION

If an error trips the frequency converter, it automatically tries to restart the compressor after 30 s (unless the error is severe and causes a trip lock). See also *parameter 14-20 Reset Mode* and *parameter 14-21 Automatic Restart Time*.

4.1.2 Open Loop with External Reference

1. Apply analog speed reference signal (0-10 V) on terminal 53 using the terminal 55 as common. See *chapter 3.3.14 Basic Examples of Control Connections*.
2. Check if switch A53 is positioned to U (voltage) instead of I (current). The switch A53 is on the

frequency converter and is visible when the LCP is removed.

3. Ready to Run: If the frequency converter is supplied with display: Press [Hand On] to set a local speed reference in the display (good for testing purposes). Press [Auto On] for running in operation and with an external reference.

Figure 4.1 shows the screen after configuring the frequency converter for *Speed Open loop* application, *Hand On mode*.



Figure 4.1 Speed Open Loop, Hand On Mode

This is what the screen will look like after configuring the frequency converter for *Speed Open loop* application, *Auto On mode*:



130BA555.10

Figure 4.2 Speed Open Loop, Auto On Mode

4. Done.

4.1.3 PID Closed Loop with 4-20 mA Pressure Transmitter

1. Connect pressure transmitter to analog input on terminal 54 according to *chapter 3.3.14 Basic Examples of Control Connections*.
2. Make sure that the switch for analogue input 54 is set to "I" for current input.
3. Press [Quick Menu], go to "PID Closed Loop" and then to "Basic PID Settings) menu. Now change parameters to

parameter 1-00 Configuration Mode: Select [3] Process
 parameter 3-01 Reference/Feedback Unit: Select [71] Psi
 parameter 3-02 Minimum Reference and parameter 3-03 Maximum Reference: Enter the lower and upper limits of the setpoint range [psi].
 parameter 3-15 Reference Resource 1: Select [0] No function for fixed setpoint.
 parameter 6-22 Terminal 54 Low Current + parameter 6-23 Terminal 54 High Current: The values of these parameters should match the output of the pressure transmitter (4-20 mA for example is the factory setting).
 parameter 6-24 Terminal 54 Low Ref./Feedb. Value + parameter 6-25 Terminal 54 High Ref./Feedb. Value: Set range of pressure transmitter (factory setting -14/+174 psi)
 Return to parameter 3-13 Reference Site: Select [2] Local to run with a fixed setpoint adjustable via LCP. Select [1] Remote if the setpoint is given by

the analog input (as defined in parameter 3-15 Reference Resource 1).

4. Press [Quick Menu], go to My Personal Menu, go to parameter 0-22 Display Line 1.3 Small and select [1652] Feedback [unit]. The pressure [psi] is going to be shown in the upper right corner of the display

This is what the screen will look like, after configuring the frequency converter for Closed loop application.



Figure 4.3 Closed Loop

5. Ready to Run: Press [Hand On] and set reference in psi using the arrows on the display. Before leaving the site, never forget the next step.
6. Ready to Run: Press [Auto On].

For more details on PID Closed Loop, see Figure 4.4.

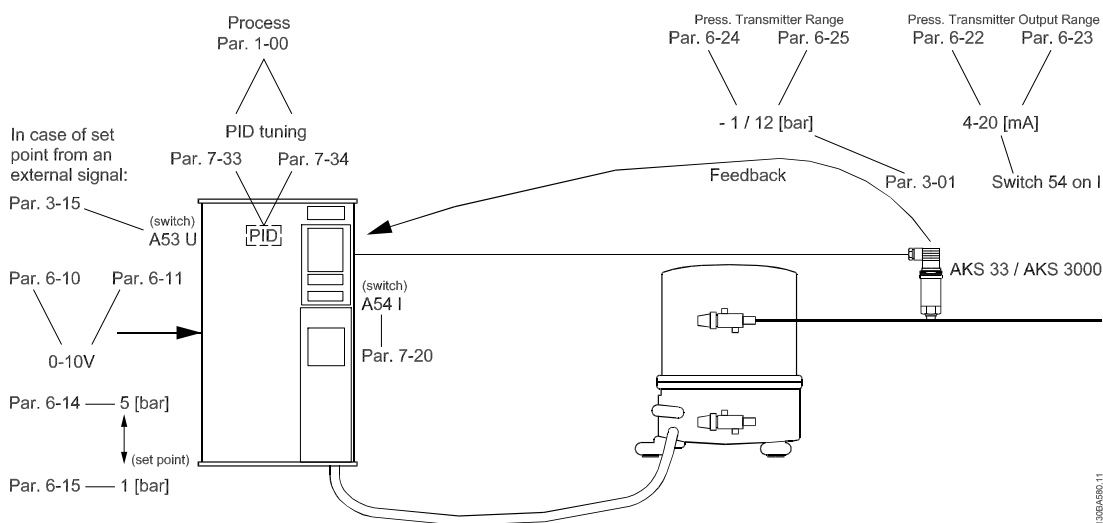

Figure 4.4 Example of Closed Loop Application

4.1.4 Other Compressor Features

To set up other dedicated compressor features press [Quick Menu] and go to Q4 or follow *Figure 4.5*.

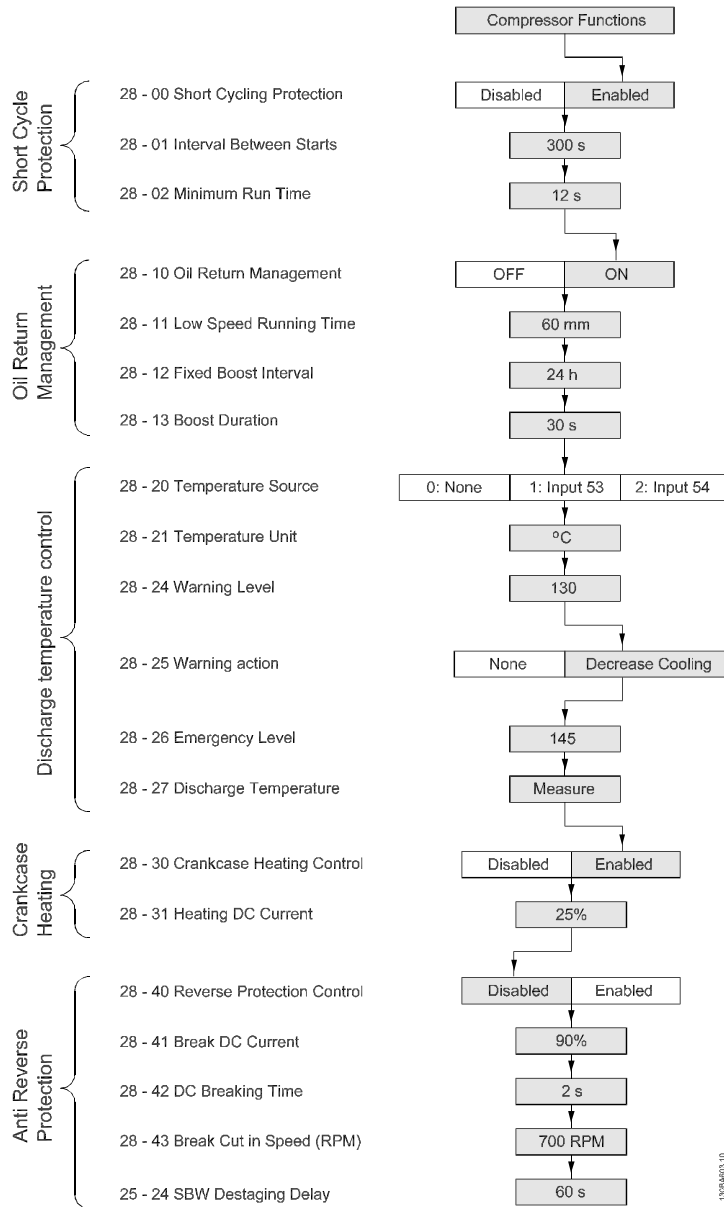

Figure 4.5 Flowchart

5 How to Program

5.1 How to Program on the Graphical LCP

5.1.1 Control Panel

The following instructions are valid for the graphical LCP (LCP 102):

The control panel is divided into four functional groups:

1. Graphical display with Status lines. All data is displayed in a graphical LCP display, which can show up to five items of operating data while displaying [Status].
2. Menu keys and indicator lights - changing parameters and switching between display functions.
3. Navigation keys and indicator lights (LEDs).
4. Operation keys and indicator lights (LEDs).

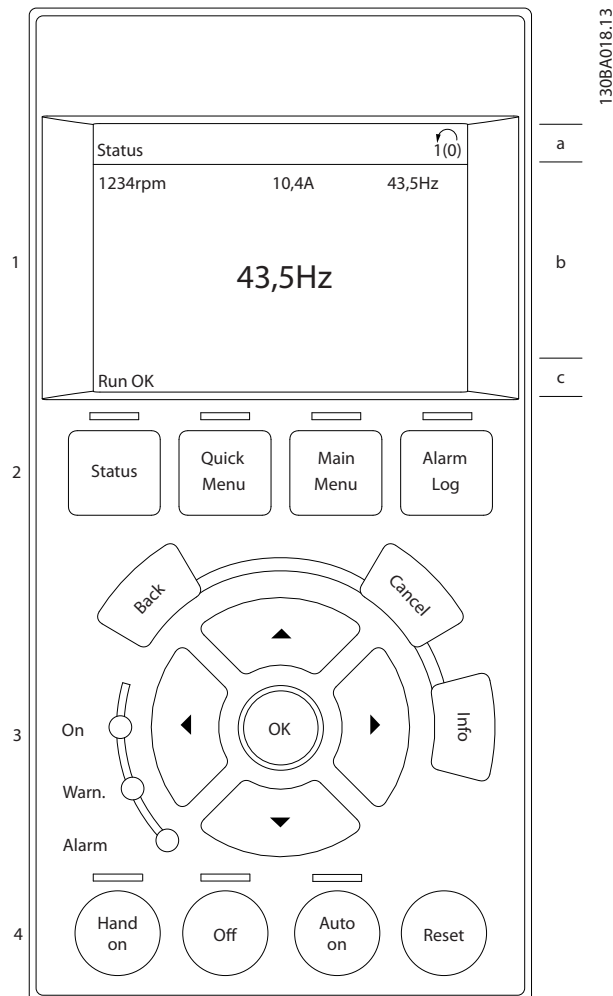

Figure 5.1 Overview of LCP

5.1.2 Display Lines

a. Status line:

Status messages displaying icons and graphic.

b. Line 1-2:

Operator data lines displaying data defined or chosen by the user. By pressing the [Status] key, up to one extra line can be added.

c. Status line:

Status messages displaying text.

5.1.3 Display Contrast Adjustment

Press [Status] and [▼] for darker display

Press [Status] and [▲] for brighter display

5.1.4 Indicator Lights

If certain threshold values are exceeded, the alarm and/or warning LED lights up. A status and alarm text appear on the control panel. The on LED is activated when the frequency converter receives mains voltage.

- Green LED/On: Control section is working.
- Yellow LED/Warn.: Indicates a warning.
- Flashing Red LED/Alarm: Indicates an alarm

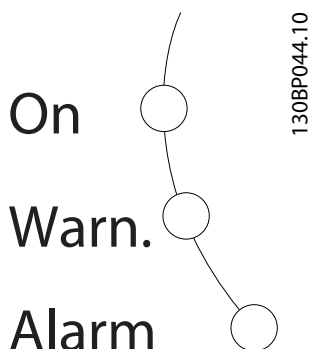

Figure 5.2 Indicator Lights

5.2 LCP Keys

5.2.1 Function Keys

The control keys are divided into functions. The keys below the display and indicator lamps are used for parameter set-up, including choice of display indication during normal operation.



Figure 5.3 Function Keys

[Status] indicates the status of the frequency converter and/or the compressor motor. Choose between 3 different readouts by pressing the [Status] key: 5 line readouts, 4 line readouts or Smart Logic Control by pushing [Status] twice.

Press [Status] to select the display mode or to change back to Display mode from either Quick Menu mode, Main Menu mode or Alarm mode. Also press [Status] to toggle single or double read-out mode.

[Quick Menu] allows quick access to different Quick Menus such as:

- Q1 - My Personal Menu
- Q2 - Quick Set-up
- Q3 - PID Process Loop
- Q4 - Compressor Functions
- Q5 - Changes Made
- Q6 - Loggings
- Q7 - Load Profile

Use [Quick Menu] for programming the parameters belonging to the Quick Menu. It is possible to switch directly between Quick Menu mode and Main Menu mode.

5.2.2 Navigation Keys

The 4 navigation keys are used to navigate between the different choices available in [Quick Menu], [Main Menu] and [Alarm Log]. Press the keys to move the cursor. [OK] is used for choosing a parameter marked by the cursor and for enabling the change of a parameter and loggings from Quick Menu.

5.2.3 Local Control Keys

Local control keys for local control are found at the bottom of the control panel.



Figure 5.4 Local Control Keys

[Hand On] enables control of the frequency converter via the LCP. [Hand on] also starts the motor compressor, and it is now possible to enter the motor compressor speed data by means of the arrow keys. The key can be selected as [1] Enable or [0] Disable via *parameter 0-40 [Hand on] Key on LCP*.

External stop signals activated by means of control signals or a serial bus will override a "start" command via the LCP. The following control signals will still be active when [Hand on] is activated:

- [Hand On] - [Off] - [Auto On]
- Reset
- Coasting stop inverse
- Reversing
- Set-up select lsb (least significant bit) - Set-up select msb (most significant bit)
- Stop command from serial communication
- Quick stop
- DC brake

[Off] stops the connected motor compressor. The key can be selected as [1] Enable or [0] Disable via *parameter 0-41 [Off] Key on LCP*.

If no external stop function is selected and the [Off] key is inactive the motor compressor can be stopped by disconnecting the voltage.

[Auto On] enables the frequency converter is to be controlled via the control terminals and/or serial communication. When a start signal is applied on the control terminals and/or the bus, the frequency converter will start. The key can be selected as [1] Enable or [0] Disable via *parameter 0-42 [Auto on] Key on LCP*.

NOTICE!

An active HAND-OFF-AUTO signal via the digital inputs has higher priority than the control keys [Hand on] and [Auto on].

[Reset] is used for resetting the frequency converter after an alarm (trip). It can be selected as [1] Enable or [0] Disable via *parameter 0-43 [Reset] Key on LCP*.

The **parameter shortcut** can be carried out by holding down the [Main Menu] key for 3 seconds. The parameter shortcut allows direct access to any parameter.

5.2.4 Quick Transfer of Parameter Settings

Once the set-up of a frequency converter is complete, store the data in the LCP or on a PC via MCT 10 Set-up Software.

5.2.5 Data Storage in LCP

1. Go to *parameter 0-50 LCP Copy* in the Main Menu.
2. Press [OK].
3. Select [1] All to LCP.
4. Press [OK].

All parameter settings are now stored in the LCP indicated by the progress bar. When 100% is reached, press [OK].

NOTICE!

Stop the motor compressor before performing this operation. The LCP can now be connected to another frequency converter and the parameter settings copied to this frequency converter as well.

5.2.6 Initialization to Default Settings

Initialize the frequency converter to default settings in two ways:

Recommended initialization (via parameter 14-22 Operation Mode)

1. Select *parameter 14-22 Operation Mode*.
2. Press [OK].
3. Select [2] Initialization.
4. Press [OK].
5. Disconnect mains supply and wait until the display turns off.
6. Reconnect the mains supply.
7. Drive initialized [A80] (Alarm 80) appears - the frequency converter is now reset.

parameter 14-22 Operation Mode initializes all except:

- parameter 8-30 Protocol
- parameter 8-31 Address
- parameter 8-32 FC Port Baud Rate
- parameter 8-33 Parity / Stop Bits
- parameter 8-34 Estimated cycle time
- parameter 8-35 Minimum Response Delay
- parameter 8-36 Max Response Delay

- parameter 8-37 Max Inter-Char Delay
- parameter 14-50 RFI 1
- parameter 15-00 Operating hours
- parameter 15-01 Running Hours
- parameter 15-02 kWh Counter
- parameter 15-03 Power-ups
- parameter 15-04 Over Temps
- parameter 15-05 Over Volts
- parameter 15-20 Historic Log: Event
- parameter 15-21 Historic Log: Value
- parameter 15-22 Historic Log: Time
- parameter 15-30 Fault Log: Error Code
- parameter 15-31 Fault Log: Value
- parameter 15-32 Fault Log: Time

The parameter settings stored in the LCP are now transferred to the frequency converter indicated by the progress bar. When 100% is reached, press [OK].

Manual initialization

1. Disconnect from mains and wait until the display turns off.
2. Press [Status] - [Main Menu] - [OK] at the same time while power up for LCP 102, Graphical Display.
3. Release the keys after 5 s.
4. The frequency converter is now programmed according to default settings.

This procedure initializes all except:

- parameter 15-00 Operating hours
- parameter 15-03 Power-ups
- parameter 15-04 Over Temps
- parameter 15-05 Over Volts

5.2.7 Data Transfer from LCP to Frequency Converter

NOTICE!

Stop the motor compressor before performing this operation.

1. Go to *parameter 0-50 LCP Copy*.
2. Press [OK].
3. Select [2] *All from LCP*.
4. Press [OK] again.

5.2.8 Parameter Selection

In the Main menu mode, the parameters are divided into groups. Use the navigation keys for selecting a parameter group.

The following parameter groups are accessible:

- 0-** Operation/Display
- 1-** Load/Motor
- 3-** Reference/Ramps
- 4-** Limits/Warnings
- 5-** Digital In/Out
- 6-** Analog In/Out
- 7-** Controls
- 8-** Comm. and Options
- 13-** Smart Logic
- 14-** Special Functions
- 15-** Drive Information
- 16-** Data Readouts
- 25-** Cascade Controller
- 28-** Compressor Functions

After selecting a parameter group, select a parameter with the navigation keys. The middle section on the display shows the parameter number and name as well as the selected parameter value.



Figure 5.5 Display Example - Parameter Selection

5.2.9 Changing Data

The procedure for changing data is the same in both the Quick menu and the Main menu mode.

Press [OK] to change the selected parameter. The procedure for changing data depends on whether the selected parameter represents a numerical data value or a text value.

5.2.10 Changing a Text Value

If the selected parameter is a text value, change the text value by pressing the [▲]/[▼] navigation keys. [▲] increases the value and [▼] decreases the value. Place the cursor on the value and press [OK] to save.

5.2.11 Changing a Group of Numeric Data Values

If the chosen parameter represents a numeric data value, change it by pressing the navigation keys. Press [◀]/[▶] to move the cursor horizontally. Press [▲]/[▼] to change the data value. [▲] increases the data value, and [▼] decreases the data value. Place the cursor on the value and press [OK] to save.



130BA562.10

Figure 5.6 Display Example

6 Parameter Descriptions

6.1 LCP Display

6.1.1 LCP Programming

Table 6.1 lists the parameters that cannot be changed from the LCP. These parameters are defined by the compressor choice made in 1-13 Compressor Selection.

Parameter	Parameter	Parameter
parameter 1-01 Motor Control Principle	1-45 q-axis Inductance (Lq) 200% I _{NOM}	parameter 5-41 On Delay, Relay
parameter 1-03 Torque Characteristics	parameter 1-40 Back EMF at 1000 RPM	parameter 5-42 Off Delay, Relay
parameter 1-04 Overload Mode	parameter 1-47 Low Speed Torque Calibration	parameter 7-00 Speed PID Feedback Source
parameter 1-05 Local Mode Configuration	1-49 Current at min. inductance	parameter 7-02 Speed PID Proportional Gain
parameter 1-10 Motor Construction	parameter 1-62 Slip Compensation	parameter 7-03 Speed PID Integral Time
parameter 1-20 Motor Power [kW]	parameter 1-66 Min. Current at Low Speed	parameter 7-04 Speed PID Differentiation Time
parameter 1-22 Motor Voltage	parameter 1-68 Minimum Inertia	parameter 7-05 Speed PID Diff. Gain Limit
parameter 1-23 Motor Frequency	parameter 1-69 Maximum Inertia	parameter 13-10 Comparator Operand
parameter 1-24 Motor Current	parameter 1-71 Start Delay	parameter 13-11 Comparator Operator
parameter 1-25 Motor Nominal Speed	parameter 1-72 Start Function	parameter 13-12 Comparator Value
parameter 1-26 Motor Cont. Rated Torque	parameter 1-73 Flying Start	parameter 14-00 Switching Pattern
parameter 1-29 Automatic Motor Adaptation (AMA)	parameter 1-74 Start Speed [RPM]	parameter 14-01 Switching Frequency
parameter 1-30 Stator Resistance (Rs)	parameter 1-76 Start Current	parameter 14-10 Line Failure
parameter 1-31 Rotor Resistance (Rr)	parameter 1-77 Compressor Start Min Speed [RPM]	parameter 14-11 Line Voltage at Line Fault
parameter 1-33 Stator Leakage Reactance (X1)	parameter 1-79 Compressor Start Max Time to Trip	parameter 14-21 Automatic Restart Time
parameter 1-34 Rotor Leakage Reactance (X2)	parameter 1-86 Compressor Min. Speed for Trip [RPM]	parameter 14-25 Trip Delay at Torque Limit
parameter 1-35 Main Reactance (Xh)	parameter 3-82 Starting Ramp Up Time	parameter 14-26 Trip Delay at Inverter Fault
parameter 1-36 Iron Loss Resistance (Rfe)	parameter 4-10 Motor Speed Direction	parameter 28-30 Crankcase Heating Control
parameter 1-37 d-axis Inductance (Ld)	parameter 4-11 Motor Speed Low Limit [RPM]	parameter 28-31 Heating DC Current
parameter 1-38 q-axis Inductance (Lq)	parameter 4-13 Motor Speed High Limit [RPM]	parameter 28-40 Reverse Protection Control
parameter 1-39 Motor Poles	parameter 4-16 Torque Limit Motor Mode	parameter 28-41 DC Brake Current
parameter 1-40 Back EMF at 1000 RPM	parameter 4-18 Current Limit	parameter 28-42 DC Braking Time
1-44 d-axis Inductance (Ld) 200% I _{NOM}	parameter 4-19 Max Output Frequency	parameter 28-43 DC Brake Cut In Speed [RPM]

Table 6.1 Compressor Related Parameters

6.2 Par. Group 0 - Operation and Display

6.2.1 0-0* Basic Settings

0-01 Language		
Option:	Function:	
[0]	English	
[1]	Deutsch	
[2]	Francais	
[3]	Dansk	
[4]	Spanish	
[5]	Italiano	
[10]	Chinese	
[28]	Bras.port	
[39]	Korean	
[42]	Trad.Chinese	
[49]	Russian	

0-02 Motor Speed Unit		
Option:	Function:	
		Select display of motor speed parameters (i.e. references, feedbacks and limits) in terms of shaft speed (RPM) or output frequency to the motor (Hz).
[0]	RPM	
[1]	Hz	

NOTICE!

This parameter cannot be adjusted while the motor is running.

0-04 Operating State at Power-up (Hand)		
Option:	Function:	
		Selects the operating mode upon reconnection of the frequency converter to mains voltage after power down in Hand (local) operation mode.
[0]	Resume	Restarts the frequency converter, maintaining the same and the same start/stop settings (applied by [Hand On/Off]) as before the frequency converter was powered down.
[1]	Forced stop, ref=old	Restarts the frequency converter with a saved local reference, after mains voltage reappears and after pressing [Hand On].
[2]	Forced stop, ref=0	Resets the local reference to 0 upon restarting the frequency converter.

0-10 Active Set-up		
Option:	Function:	
		Select the set-up to control the frequency converter functions.

0-10 Active Set-up		
Option:	Function:	
[0]	Factory setup	Cannot be changed. It contains the Danfoss data set, and can be used as a data source when returning the other set-ups to a known state.
[1]	Set-up 1	[1] Set-up 1 to [4] Set-up 4 are the four separate parameter set-ups within which all parameters can be programmed.
[2]	Set-up 2	
[3]	Set-up 3	
[4]	Set-up 4	
[9]	Multi Set-up	Remote selection of set-ups using digital inputs and the serial communication port. This set-up uses the settings from <i>parameter 0-12 This Set-up Linked to</i> . Stop the frequency converter before making changes to open- and closed loop functions

Use *parameter 0-51 Set-up Copy* to copy a set-up to one or all other set-ups. Stop the frequency converter before switching between set-ups where parameters marked 'not changeable during operation' have different values. To avoid conflicting settings of the same parameter within two different set-ups, link the set-ups together using *parameter 0-12 This Set-up Linked to*. Parameters which are 'not changeable during operation' are marked FALSE in the parameter lists in *chapter 6.16 Parameter Lists*.

0-11 Edit Set-up		
Option:	Function:	
		Select the set-up to be edited (i.e. programmed) during operation; either the active set-up or one of the inactive set-ups.
[0]	Factory setup	Cannot be edited but it is useful as a data source to return the other set-ups to a known state.
[1]	Set-up 1	[1] Set-up 1 to [4] Set-up 4 can be edited freely during operation, independently of the active set-up.
[2]	Set-up 2	
[3]	Set-up 3	
[4]	Set-up 4	
[9]	Active Set-up	Can also be edited during operation. Edit the chosen set-up from a range of sources: LCP, FC RS-485, FC USB or up to five fieldbus sites.

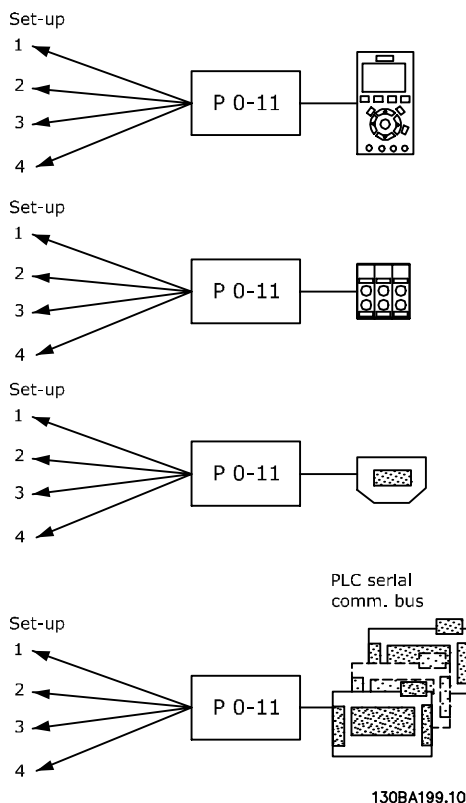
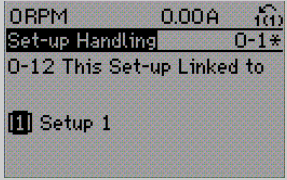
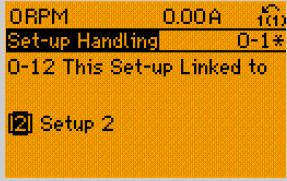

Figure 6.1 Edit Set-up

0-12 This Set-up Linked to	
Option:	Function:
	<p>To enable conflict-free changes from one set-up to another during operation, link set-ups containing parameters which are not changeable during operation. The link will ensure synchronizing of the 'not changeable during operation' parameter values when moving from one set-up to another during operation. 'Not changeable during operation' parameters can be identified by the label FALSE in the parameter lists in <i>chapter 6.16 Parameter Lists</i>.</p> <p><i>Parameter 0-12 This Set-up Linked to</i> is used by Multi set-up in <i>parameter 0-10 Active Set-up</i>. Multi set-up is used to move from one set-up to another during operation (i.e. while the motor is running).</p> <p>Example: Use Multi set-up to shift from Set-up 1 to Set-up 2 whilst the motor is running. Program in Set-up 1 first, then ensure that Set-up 1 and Set-up 2 are synchronized (or 'linked'). synchronization can be performed in two ways:</p> <ol style="list-style-type: none"> 1. Change the edit set-up to [2] Set-up 2 in <i>parameter 0-11 Edit Set-up</i> and set

0-12 This Set-up Linked to	
Option:	Function:
	<p><i>parameter 0-12 This Set-up Linked to</i> to [1] Set-up 1. This will start the linking (synchronizing) process.</p>  <p>Figure 6.2 Set-up 1</p> <p>OR</p> <ol style="list-style-type: none"> 2. While still in Set-up 1, copy Set-up 1 to Set-up 2. Then set <i>parameter 0-12 This Set-up Linked to</i> to [2] Set-up 2. This will start the linking process.  <p>Figure 6.3 Set-up 2</p> <p>After the link is complete, <i>parameter 0-13 Readout: Linked Set-ups</i> will read {1,2} to indicate that all 'not changeable during operation' parameters are now the same in Set-up 1 and Set-up 2. If there are changes to a 'not changeable during operation' parameter, e.g. <i>parameter 1-30 Stator Resistance (Rs)</i>, in Set-up 2, they will also be changed automatically in Set-up 1. A switch between Set-up 1 and Set-up 2 during operation is now possible.</p>
[0]	Not linked
[1]	Set-up 1
[2]	Set-up 2
[3]	Set-up 3
[4]	Set-up 4

0-13 Readout: Linked Set-ups														
Array [5]														
Range:	Function:													
0 * [0 - 255]	View a list of all the set-ups linked by means of <i>parameter 0-12 This Set-up Linked to</i> . The parameter has one index for each parameter set-up. The parameter value displayed for each index represents which set-ups are linked to that parameter set-up.													
	<table border="1"> <thead> <tr> <th>Index</th> <th>LCP value</th> </tr> </thead> <tbody> <tr> <td>0</td> <td>{0}</td> </tr> <tr> <td>1</td> <td>{1,2}</td> </tr> <tr> <td>2</td> <td>{1,2}</td> </tr> <tr> <td>3</td> <td>{3}</td> </tr> <tr> <td>4</td> <td>{4}</td> </tr> </tbody> </table>	Index	LCP value	0	{0}	1	{1,2}	2	{1,2}	3	{3}	4	{4}	
Index	LCP value													
0	{0}													
1	{1,2}													
2	{1,2}													
3	{3}													
4	{4}													
<p>Table 6.3 Example: Set-up 1 and Set-up 2 are linked</p>														

0-14 Readout: Edit Set-ups / Channel		
Range:	Function:	
0 * [-2147483648 - 2147483647]	View the setting of <i>parameter 0-11 Edit Set-up</i> for each of the four different communication channels. When the number is displayed in hex, as it is in the LCP, each number represents one channel. Numbers 1-4 represent a set-up number; 'F' means factory setting; and 'A' means active set-up. The channels are, from right to left: LCP, FC-bus, USB, HPFB1-5. Example: The number AAAAAA21h means that the FC bus selected Set-up 2 in <i>parameter 0-11 Edit Set-up</i> , the LCP selected Set-up 1 and all others used the active set-up.	

6.2.2 0-2* LCP Display

Define the display in the Graphical Logic Control Panel.

0-20 Display Line 1.1 Small		
Option:	Function:	
		Select a variable for display in line 1, left position.
[0]	None	
[953]	Profibus Warning Word	
[1005]	Readout Transmit Error Counter	
[1006]	Readout Receive Error Counter	
[1007]	Readout Bus Off Counter	
[1013]	Warning Parameter	

0-20 Display Line 1.1 Small		
Option:	Function:	
[1501]	Running Hours	
[1502]	kWh Counter	
[1508]	Number of Starts	
[1509]	Number of Auto Resets	
[1600]	Control Word	
[1601]	Reference [Unit]	
[1602]	Reference %	
[1603]	Status Word	
[1605]	Main Actual Value [%]	
[1609]	Custom Readout	
[1610]	Power [kW]	
[1611]	Power [hp]	
[1612]	Motor Voltage	
[1613]	Frequency	
[1614]	Motor current	
[1615]	Frequency [%]	
[1616]	Torque [Nm]	
[1617]	Speed [RPM]	
[1618]	Motor Thermal	
[1619]	KTY sensor temperature	
[1620]	Motor Angle	
[1622]	Torque [%]	
[1630]	DC Link Voltage	
[1632]	Brake Energy /s	
[1633]	Brake Energy /2 min	
[1634]	Heatsink Temp.	
[1635]	Inverter Thermal	
[1636]	Inv. Nom. Current	
[1637]	Inv. Max. Current	
[1638]	SL Controller State	
[1639]	Control Card Temp.	
[1650]	External Reference	
[1651]	Pulse Reference	
[1652]	Feedback[Unit]	
[1653]	Digi Pot Reference	
[1654]	Feedback 1 [Unit]	
[1655]	Feedback 2 [Unit]	
[1660]	Digital Input	
[1661]	Terminal 53 Switch Setting	
[1662]	Analog Input 53	
[1663]	Terminal 54 Switch Setting	
[1664]	Analog Input 54	
[1665]	Analog Output 42 [mA]	
[1666]	Digital Output [bin]	
[1667]	Freq. Input #29 [Hz]	
[1668]	Freq. Input #33 [Hz]	
[1669]	Pulse Output #27 [Hz]	
[1670]	Pulse Output #29 [Hz]	
[1671]	Relay Output [bin]	
[1672]	Counter A	

0-20 Display Line 1.1 Small	
Option:	Function:
[1673]	Counter B
[1680]	Fieldbus CTW 1
[1682]	Fieldbus REF 1
[1684]	Comm. Option STW
[1685]	FC Port CTW 1
[1686]	FC Port REF 1
[1690]	Alarm Word
[1691]	Alarm Word 2
[1692]	Warning Word
[1693]	Warning Word 2
[1694]	Ext. Status Word
[2580]	Cascade Status
[2581]	Compressor Status
[2587]	Inverse Interlock
[2827]	Discharge Temperature
[9913]	Idle time
[9914]	Paramdb requests in queue
[9917]	tCon1 time
[9918]	tCon2 time
[9919]	Time Optimize Measure

0-25 My Personal Menu	
Range:	Function:
Size related* [0 - 9999]	Define up to 20 parameters to include in the Q1 Personal Menu, accessible via the [Quick Menu] key on the LCP. The parameters will be displayed in the Q1 Personal Menu in the order they are programmed into this array parameter. Delete parameters by setting the value to « 0000 ».

0-21 Display Line 1.2 Small	
Option:	Function:
	Options are the same as in <i>parameter 0-20 Display Line 1.1 Small</i>
[1614] * Motor Current [A]	

0-22 Display Line 1.3 Small	
Option:	Function:
	Options are the same as in <i>parameter 0-20 Display Line 1.1 Small</i> .
[1610] * Power [kW]	

0-23 Display Line 2 Large	
Option:	Function:
	Options are the same as in <i>parameter 0-20 Display Line 1.1 Small</i> .
[1613] * Frequency [Hz]	

0-24 Display Line 3 Large	
Option:	Function:
	Options are the same as in <i>parameter 0-20 Display Line 1.1 Small</i> .
[1662] * Analog Input 53	

0-30 Unit for User-defined Readout	
Option:	Function:
	It is possible to program a value to be shown in the display of the LCP. The value will have a linear, squared or cubed relation to speed. This relation will depend on the unit selected (see). The actual calculated value can be read in <i>parameter 16-09 Custom Readout</i> , and/or shown in the display by selecting [16-09] <i>Custom Readout</i> in <i>parameter 0-20 Display Line 1.1 Small</i> to <i>parameter 0-24 Display Line 3 Large</i> .
[0]	None
[1]	%
[5]	PPM
[10]	min
[11]	RPM
[12]	PULSE/s
[20]	liter / sec.
[21]	liter / min
[22]	liter / hr.
[23]	m ³ / sec.
[24]	m ³ /min
[25]	m ³ / hr.
[30]	kg / sec.
[31]	kg/min
[32]	kg / hr.
[33]	ton / min
[34]	ton / hr.
[40]	m / sec.
[41]	m/min
[45]	m
[60]	°C
[70]	mbar
[71]	bar
[72]	Pa
[73]	kPa
[74]	m WG
[80]	kW
[120]	GPM
[121]	gal / sec.
[122]	gal/min
[123]	gal / hr.
[124]	CFM
[125]	ft ³ /s

0-30 Unit for User-defined Readout	
Option:	Function:
[126]	ft ³ /min
[127]	ft ³ /h
[130]	lbs / sec.
[131]	lbs / min.
[132]	lbs / hr.
[140]	ft/s
[141]	ft/min
[145]	ft
[160]	°F
[170]	psi
[171]	lb/in ²
[172]	in. wtr. gage
[173]	ft WG
[180]	HP

0-31 Min Value of User-defined Readout		
Range:	Function:	
0 CustomReadoutUnit*	[-999999.99 - par. 0-32 CustomReadoutUnit]	This parameter sets the min. value of the custom defined readout (occurs at zero speed). Only possible to set different from 0 is when selecting a linear unit in <i>parameter 0-30 Unit for User-defined Readout</i> . For Quadratic and Cubic units the minimum value will be 0.

0-32 Custom Readout Max Value		
Range:	Function:	
100 CustomReadoutUnit*	[par. 0-31 - 999999.99 CustomReadoutUnit]	This parameter sets the max value to be shown when the speed of the motor has reached the set value for <i>parameter 4-13 Motor Speed High Limit [RPM]</i> or <i>parameter 4-14 Motor Speed High Limit [Hz]</i> (depends on setting in <i>parameter 0-02 Motor Speed Unit</i>).

6.2.3 0-4* LCP Keypad

Enable and disable individual keys on the LCP keypad.

0-40 [Hand on] Key on LCP	
Option:	Function:
	If <i>parameter 0-40 [Hand on] Key on LCP</i> is included in the Quick Menu, then define the password in <i>parameter 0-65 Quick Menu Password</i> .

0-40 [Hand on] Key on LCP		
Option:	Function:	
[0]	Disabled	Prevents accidental start of the frequency converter in Hand mode.
[1]	Enabled	Prevents unauthorised start in Hand mode.
[2]	Password	

0-41 [Off] Key on LCP		
Option:	Function:	
		Options are the same as in <i>parameter 0-40 [Hand on] Key on LCP</i> .

0-42 [Auto on] Key on LCP		
Option:	Function:	
		Options are the same as in <i>parameter 0-40 [Hand on] Key on LCP</i> .

0-43 [Reset] Key on LCP		
Option:	Function:	
		Options are the same as in <i>parameter 0-40 [Hand on] Key on LCP</i> .

6.2.4 0-5* Copy/Save

Copy parameter settings between set-ups and to/from the LCP.

0-50 LCP Copy		
Option:	Function:	
[0] *	No copy	
[1]	All to LCP	Copies all parameters in all set-ups from the frequency converter memory to the LCP memory.
[2]	All from LCP	Copies all parameters in all set-ups from the LCP memory to the frequency converter memory.
[3]	Size indep. from LCP	Copies only the parameters that are independent of the motor size.

0-51 Set-up Copy		
Option:	Function:	
[0]	No copy	
[1]	Copy to set-up 1	Copies all parameters in the present edit set-up (defined in par. 0-11 Edit Set-up) to Set-up 1. Likewise, select the option corresponding to the other set-up(s).
[2]	Copy to set-up 2	
[3]	Copy to set-up 3	
[4]	Copy to set-up 4	
[9]	Copy to all	Copies the parameters in the present set-up over to each of the set-ups 1 to 4.

6.2.5 0-6* Password

Define password access to menus.

0-60 Main Menu Password

Option: **Function:**

[Size related] *	Define the password for access to the Main Menu via the [Main Menu] key. If <i>parameter 0-61 Access to Main Menu w/o Password</i> is set to [0] Full access, this parameter will be ignored.
------------------	---

0-60 Main Menu Password

Range: **Function:**

100 *	[0 - 999]	
-------	------------	--

0-65 Quick Menu Password

Option: **Function:**

	Define the password for access to the Quick Menu via the [Quick Menu] key. If <i>parameter 0-66 Access to Quick Menu w/o Password</i> is set to [0] Full access, this parameter will be ignored.
--	--

0-66 Access to Quick Menu w/o Password

Option: **Function:**

		NOTICE! If <i>parameter 0-61 Access to Main Menu w/o Password</i> is set to [0] Full access, this parameter will be ignored.
[0] *	Full access	Disables the password defined in <i>parameter 0-65 Quick Menu Password</i> .
[1]	Read only	Prevents unauthorized editing of Quick Menu parameters.
[2]	No access	Prevents unauthorized viewing and editing of Quick Menu parameters.

6.3 Par. Group 1 - Load and Motor

6.3.1 1-0* General Settings

Define whether the frequency converter operates in speed mode or torque mode; and whether the internal PID control should be active or not. All parameters from *parameter 1-01 Motor Control Principle* (included) to *parameter 1-81 Min Speed for Function at Stop [RPM]* (included) are read only. Only *parameter 1-13 Compressor Selection* remains accessible for compressor selection.

1-00 Configuration Mode

Option:	Function:
	<p>NOTICE! This parameter cannot be adjusted while the motor is running.</p>
	Select the application control principle to be used when a Remote Reference (via analog input) is active. A Remote Reference can only be active when <i>3-13 Reference Site</i> is set to [0] or [1].
[0] *	Speed open loop Enables speed control (without feedback signal from motor) to the input signal over the compressor speed range.
[3]	Process Enables the use of process control in the frequency converter. The process control parameters are set in parameter groups <i>7-2* Process PID Feedback</i> and <i>7-3* Process PID Control</i> .

1-13 Compressor Selection

Range:	Function:
	<p>The default setting of most of the parameters in the frequency converter (e.g. motor data, limits, ramps etc.) depends upon the compressor and system refrigerant selected for the frequency converter.</p> <p>The frequency converter selects the default compressor based upon the power size and voltage range for the frequency converter. Under normal circumstances this should not be changed. During test/repair situations a different compressor can be selected – or if the system is not using the default refrigerant.</p> <p>NOTICE! If the compressor selection is changed, then all dependent parameters reset to default and any user settings will be lost.</p>
Size dependent.	□ Select the compressor/refrigerant combination for the system.

6.4 Par. Group 3 - Reference/Ramps

6.4.1 3-0* Reference Limits

Parameters for reference handling, definition of limitations, and configuration of the reaction of the frequency converter to changes.

3-00 Reference Range

Option:	Function:
	Select the range of the reference signal and the feedback signal. Signal values can be positive only, or positive and negative. The minimum limit may have a negative value, unless [1] <i>Speed closed loop</i> control is selected in <i>1-00 Configuration Mode</i> .
[0] *	Min. - Max For positive values only
[1]	-Max - +Max For both positive and negative values

3-01 Reference/Feedback Unit

Option:	Function:
	Select the unit to be used in Process PID Control references and feedbacks.
[0]	None
[71] *	bar
[60]	°C
[160]	°F
[170]	psi

3-02 Minimum Reference

Option:	Function:
	Enter the minimum reference. The minimum reference is the lowest value obtainable by summing all references. Minimum reference is active only when <i>parameter 3-00 Reference Range</i> is set to [0] <i>Min.- Max.</i> .
	<p>The minimum reference unit matches:</p> <ul style="list-style-type: none"> The choice of configuration in <i>parameter 1-00 Configuration Mode</i>: for [1] <i>Speed closed loop</i>. The unit selected in <i>parameter 3-01 Reference/Feedback Unit</i>.

3-03 Maximum Reference

Option:	Function:
	Enter the maximum reference.

3-10 Preset Reference

Range:	Function:
0.00%* - 100.00 %]	Must remain 0 for Open Loop Control. The preset reference is stated as a percentage of the value Ref_{MAX} (<i>parameter 3-03 Maximum Reference</i>) or as a percentage of the other external references. If a Ref_{MIN} 0 (<i>parameter 3-02 Minimum Reference</i>) is programmed, the preset reference is calculated as a percentage of the full reference range, i.e. on the basis of the difference between Ref_{MAX} and Ref_{MIN} . Afterwards, the value is added to Ref_{MIN} . When using preset references, select [16] <i>Preset ref. bit 0</i> , [17] <i>Preset ref. bit 1</i> or [18] <i>Preset ref. bit 2</i> for the corresponding digital inputs in parameter group 5-1* <i>Digital Inputs</i> .

3-12 Catch up/slow-down value

Range:	Function:
0 %* [0 - 100 %]	Enter a percentage (relative) value to be either added to or deducted from the actual reference for Catch up or Slow down respectively. If <i>Catch up</i> is selected via one of the digital inputs (<i>parameter 5-10 Terminal 18 Digital Input</i> to <i>parameter 5-15 Terminal 33 Digital Input</i>), the percentage (relative) value is added to the total reference. If <i>Slow down</i> is selected via one of the digital inputs (<i>parameter 5-10 Terminal 18 Digital Input</i> to <i>parameter 5-15 Terminal 33 Digital Input</i>), the percentage (relative) value is deducted from the total reference. Obtain extended functionality with the DigiPot function. See parameter group 3-9* <i>Digital Potentiometer</i> .

3-13 Reference Site

Option:	Function:
	Select which reference site to activate.
[0]	Linked to Hand / Auto Use the local reference when in Hand mode; or the remote reference when in Auto mode
[1]	Remote Use the remote reference in both Hand mode and Auto mode
[2]	Local Use the local reference in both Hand mode and Auto mode

3-14 Preset Relative Reference

Range:	Function:
0.00%* [-100.00 - 100.00 %]	Define a fixed value (in %) to be added to the variable value (defined in 3-18 <i>Relative Scaling Reference Source</i>). The sum of the fixed and variable values is multiplied with the actual reference. This product is then

3-14 Preset Relative Reference

Range:	Function:
	added to the actual reference $(X+X*Y/100)$ to give the resultant actual reference.

3-15 Reference Resource 1

Option:	Function:
	NOTICE! This parameter cannot be adjusted while the motor is running.
	Select the reference input to be used for the first reference signal. <i>parameter 3-15 Reference Resource 1, parameter 3-16 Reference Resource 2 and parameter 3-17 Reference Resource 3</i> define up to three different reference signals. The sum of these reference signals defines the actual reference.
[0]	No function
[1] *	Analog input 53
[2]	Analog input 54
[7]	Frequency input 29
[8]	Frequency input 33
[11]	Local bus reference
[20]	Digital pot.meter

3-16 Reference Resource 2

Option:	Function:
	NOTICE! This parameter cannot be adjusted while the motor is running.
	Select the reference input to be used for the second reference signal. Parameters <i>parameter 3-15 Reference Resource 1, parameter 3-16 Reference Resource 2 and parameter 3-17 Reference Resource 3</i> define up to three different reference signals. The sum of these reference signals defines the actual reference. Same options as <i>parameter 3-15 Reference Resource 1</i> .
[0] *	No function

3-17 Reference Resource 3

Option:	Function:
	NOTICE! This parameter cannot be adjusted while the motor is running.
	Select the reference input to be used for the third reference signal. <i>parameter 3-15 Reference Resource 1, parameter 3-16 Reference Resource 2 and parameter 3-17 Reference Resource 3</i> define up to three different reference signals. The sum of these reference signals defines the actual reference. Same options as <i>parameter 3-15 Reference Resource 1</i> .
[0] *	No function

3-18 Relative Scaling Reference Resource

Option:	Function:
	Select a variable value to be added to the fixed value (defined in <i>3-14 Preset Relative Reference</i>). The sum of the fixed and variable values is multiplied with the actual reference. This product is then added to the actual reference $(X+X*Y/100)$ to give the resultant actual reference. Same options as <i>parameter 3-15 Reference Resource 1</i> .
[0] *	No function

3-19 Jog Speed [RPM]

Range:	Function:
Size related* [0 - par. 4-13 RPM]	Enter a value for the jog speed n_{JOG} , which is a fixed output speed. The frequency converter runs at this speed when the jog function is activated. The maximum limit is defined in <i>parameter 4-13 Motor Speed High Limit [RPM]</i> . See also <i>parameter 3-80 Jog Ramp Time</i> .

3-40 Ramp 1 Type

Option:	Function:
	Select the ramp type, depending on requirements for acceleration/deceleration. A linear ramp will give constant acceleration during ramping.
[0] *	Linear

3-41 Ramp Up Time Running (sec)

Range:	Function:
5 s min.* [Comp dependent]	Enter the ramp-up time, i.e. the acceleration time to reach the system required motor speed.

3-42 Ramp-down Time Running (sec)		
Range:		Function:
0.30 s*	[0.01 - 3,600.00 s]	Enter the ramp-down time, i.e., the deceleration time needed to reach minimum compressor motor speed.

3-50 Ramp 2 Type		
Option:		Function:
		Select the ramp type, depending on requirements for acceleration/deceleration. A linear ramp will give constant acceleration during ramping. An S-ramp will give non-linear acceleration, compensating for jerk in the application.
[0]	Linear	
[1]	S-ramp Const Jerk	Acceleration with lowest possible jerk
[2]	S-ramp Const Time	S-ramp based on the values set in <i>parameter 3-51 Ramp 2 Ramp-up Time</i> and <i>parameter 3-52 Ramp 2 Ramp-down Time</i>

NOTICE!

If [1] *S-ramp Const Jerk* is selected and the reference during ramping is changed the ramp time may be prolonged in order to realize a jerk free movement which may result in a longer start or stop time. Additional adjustment of the S-ramp ratios or switching initiators may be necessary.

3-51 Ramp 2 Ramp-up Time		
Range:		Function:
Size related*	[0.01 - 3600 s]	Enter the ramp-up time, i.e. the acceleration time from 0 RPM to the rated motor speed n_s . Choose a ramp-up time such that the output current does not exceed the current limit in <i>parameter 4-18 Current Limit</i> during ramping. The value 0.00 corresponds to 0.01 s in speed mode. See ramp-down time in <i>parameter 3-52 Ramp 2 Ramp-down Time</i> .
$Par. 3 - 51 = \frac{t_{acc} [s] \times n_s [RPM]}{ref [RPM]}$		

3-52 Ramp 2 Ramp-down Time		
Range:		Function:
Size related*	[0.01 - 3600 s]	Enter the ramp-down time, i.e. the deceleration time from the rated motor speed n_s to 0 RPM. Choose a ramp-down time such that no over-voltage arises in the inverter due to regenerative operation of the motor, and such that the generated current does not exceed the current limit set in <i>parameter 4-18 Current Limit</i> . The value 0.00

3-52 Ramp 2 Ramp-down Time		
Range:		Function:
		corresponds to 0.01 s in speed mode. See ramp-up time in <i>parameter 3-51 Ramp 2 Ramp-up Time</i> .
$Par. 3 - 52 = \frac{t_{dec} [s] \times n_s [RPM]}{ref [RPM]}$		

3-60 Ramp 3 Type		
Option:		Function:
		Select the ramp type, depending on requirements for acceleration and deceleration. A linear ramp will give constant acceleration during ramping. An S-ramp will give non-linear acceleration, compensating for jerk in the application.
[0]	Linear	
[1]	S-ramp Const Jerk	Accelerates with lowest possible jerk.
[2]	S-ramp Const Time	S-ramp based on the values set in <i>parameter 3-61 Ramp 3 Ramp-up Time</i> and <i>parameter 3-62 Ramp 3 Ramp-down Time</i>

NOTICE!

If [1] *S-ramp Const Jerk* is selected and the reference during ramping is changed the ramp time may be prolonged in order to realize a jerk free movement which may result in a longer start or stop time. Additional adjustment of the S-ramp ratios or switching initiators may be necessary.

3-61 Ramp 3 Ramp-up Time		
Range:		Function:
Size related*	[0.01 - 3600 s]	Enter the ramp-up time, i.e. the acceleration time from 0 RPM to the rated motor speed n_s . Choose a ramp-up time such that the output current does not exceed the current limit in <i>parameter 4-18 Current Limit</i> during ramping. The value 0.00 corresponds to 0.01 s in speed mode. See ramp-down time in <i>parameter 3-62 Ramp 3 Ramp-down Time</i> .

3-62 Ramp 3 Ramp-down Time		
Range:		Function:
Size related*	[0.01 - 3600 s]	Enter the ramp-down time, i.e. the deceleration time from the rated motor speed n_s to 0 RPM. Choose a ramp-down time such that no over-voltage arises in the inverter due to regenerative operation of the motor, and such that the generated current does not exceed the current limit set in <i>parameter 4-18 Current Limit</i> . The value 0.00

3-62 Ramp 3 Ramp-down Time	
Range:	Function:
	corresponds to 0.01 s in speed mode. See ramp-up time in <i>parameter 3-61 Ramp 3 Ramp-up Time</i> .
	$Par. 3 - 62 = \frac{t_{dec} [s] \times n_s [RPM]}{ref [RPM]}$

3-70 Ramp 4 Type	
Option:	Function:
	Select the ramp type, depending on requirements for acceleration and deceleration. A linear ramp will give constant acceleration during ramping. An S-ramp will give non-linear acceleration, compensating for jerk in the application
[0]	Linear
[1]	S-ramp Const Jerk
	Accelerates with lowest possible jerk.
[2]	S-ramp Const Time
	S-ramp based on the values set in <i>parameter 3-71 Ramp 4 Ramp-up Time</i> and <i>parameter 3-72 Ramp 4 Ramp-down Time</i> .

NOTICE!

If [1] S-ramp Const Jerk is selected and the reference during ramping is changed the ramp time may be prolonged in order to realize a jerk free movement which may result in a longer start or stop time. Additional adjustment of the S-ramp ratios or switching initiators may be necessary.

3-71 Ramp 4 Ramp-up Time	
Range:	Function:
Size related* [0.01 - 3600 s]	Enter the ramp-up time, i.e. the acceleration time from 0 RPM to the rated motor speed n_s . Choose a ramp-up time such that the output current does not exceed the current limit in <i>parameter 4-18 Current Limit</i> during ramping. The value 0.00 corresponds to 0.01 s in speed mode. See ramp-down time in <i>parameter 3-72 Ramp 4 Ramp-down Time</i> .
	$Par. 3 - 71 = \frac{t_{acc} [s] \times n_s [RPM]}{ref [RPM]}$

3-72 Ramp 4 Ramp-down Time	
Range:	Function:
Size related* [0.01 - 3600 s]	Enter the ramp-down time, i.e. the deceleration time from the rated motor speed n_s to 0 RPM. Choose a ramp-down time such that no over-voltage arises in the inverter due to regenerative operation of the motor, and such that the generated current does not exceed the current limit set in

3-72 Ramp 4 Ramp-down Time	
Range:	Function:
	<i>parameter 4-18 Current Limit</i> . The value 0.00 corresponds to 0.01 s in speed mode. See ramp-up time in <i>parameter 3-71 Ramp 4 Ramp-up Time</i> .
	$Par. 3 - 72 = \frac{t_{dec} [s] \times n_s [RPM]}{ref [RPM]}$

3-80 Jog Ramp Time	
Range:	Function:
Size related* [0.01 - 3600 s]	Enter the jog ramp time, i.e. the acceleration/ deceleration time between 0 RPM and the rated motor frequency n_s . Ensure that the resultant output current required for the given jog ramp time does not exceed the current limit in <i>parameter 4-18 Current Limit</i> . The jog ramp time starts upon activation of a jog signal via the LCP, a selected digital input, or the serial communication port. When jog state is disabled then the normal ramping times are valid.

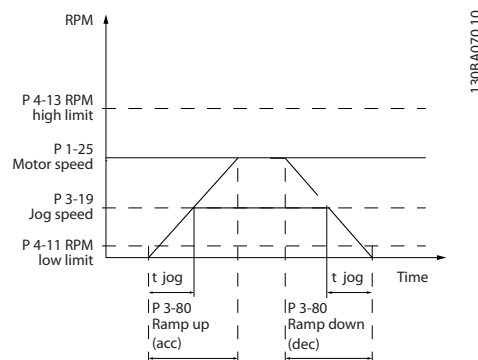

Figure 6.4 Jog Ramp Time

$$Par. 3 - 80 = \frac{t_{jog} [s] \times n_s [RPM]}{\Delta \text{ jog speed } (par. 3 - 19) [RPM]}$$

3-81 Quick Stop Ramp Time	
Range:	Function:
Size related* [0.01 - 3600 s]	Enter the quick-stop ramp-down time, i.e. the deceleration time from the synchronous motor speed to 0 RPM. Ensure that no resultant over-voltage will arise in the inverter due to regenerative operation of the motor required to achieve the given ramp-down time. Ensure also that the generated current required to achieve the given ramp-down time does not exceed the current limit (set in <i>parameter 4-18 Current Limit</i>). Quick-stop is activated by means of a signal on a

3-81 Quick Stop Ramp Time	
Range:	Function:
	selected digital input, or via the serial communication port.

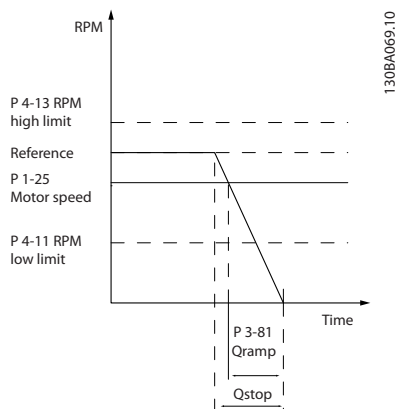

Figure 6.5 Quick Stop Ramp Time

6.5 Parameters: 4-** Limits/Warnings

6.5.1 4-1* Motor Limits

Define torque, current and speed limits for the motor, and the reaction of the frequency converter when the limits are exceeded.

A limit may generate a message on the display. A warning will always generate a message on the display or on the fieldbus. A monitoring function may initiate a warning or a trip, upon which the frequency converter will stop and generate an alarm message.

4-20 Torque Limit Factor Source		
Option:	Function:	
	Select an analog input for scaling the settings in <i>parameter 4-16 Torque Limit Motor Mode</i> and <i>parameter 4-17 Torque Limit Generator Mode</i> from 0% to 100% (or inverse). The signal levels corresponding to 0% and 100% are defined in the analog input scaling, e.g. parameter group <i>6-1* Analog Input 1</i> . This parameter is only active when <i>parameter 1-00 Configuration Mode</i> is in <i>Speed Open Loop</i> or <i>Speed Closed Loop</i> .	
[0]	No function	
[2]	Analog in 53	
[4]	Analog in 53 inv	
[6]	Analog in 54	
[8]	Analog in 54 inv	
[10]	Analog in X30-11	
[12]	Analog in X30-11 inv	
[14]	Analog in X30-12	
[16]	Analog in X30-12 inv	

4-21 Speed Limit Factor SourceOption		
Option:	Function:	
	Select an analog input for scaling the settings in <i>parameter 4-19 Max Output Frequency</i> from 0% to 100% (or vice versa). The signal levels corresponding to 0% and 100% are defined in the analog input scaling, e.g. parameter group <i>6-1* Analog Input 1</i> . This parameter is only active when <i>parameter 1-00 Configuration Mode</i> is in <i>Torque Mode</i> .	
[0] *	No function	
[2]	Analog input 53	
[4]	Analog input 53 inv	

4-21 Speed Limit Factor SourceOption		
Option:	Function:	
[6]	Analog input 54	
[8]	Analog input 54 inv	
[10]	Analog input X30-11	
[12]	Analog input X30-11 inv	
[14]	Analog input X30-12	
[16]	Analog input X30-12 inv	

6.5.2 4-5* Adjustable Warnings

Use these parameters to adjust warning limits for current, speed, reference and feedback.

Warnings are shown on the LCP, and can be programmed to be outputs or to be read out via serial bus in the Extended Status Word.

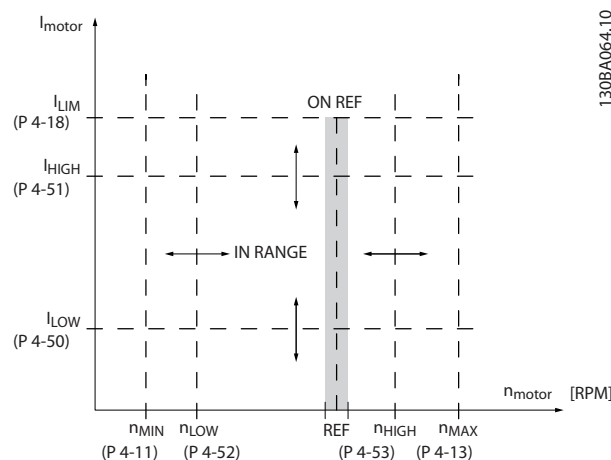

Figure 6.6 Adjustable Warnings

4-50 Warning Current Low		
Range:	Function:	
0 A* [0 - par. 4-51 A]	Enter the I_{LOW} value. When the motor current falls below this limit, the display reads <i>Current Low</i> . The signal outputs can be programmed to produce a status signal on terminal 27 or 29 and on relay output 01 or 02. Refer to <i>Figure 6.6</i> .	

4-51 Warning Current High		
Range:		Function:
Size related*	[par. 4-50 - par. 16-37 A]	Enter the I_{HIGH} value. When the motor current exceeds this limit, the display reads <i>Current High</i> . The signal outputs can be programmed to produce a status signal on terminal 27 or 29 and on relay output 01 or 02.

4-52 Warning Speed Low		
Range:		Function:
Size related*	[0 - par. 4-53 RPM]	Enter the n_{LOW} value. When the motor speed exceeds this limit, the display reads <i>Speed Low</i> . The signal outputs can be programmed to produce a status signal on terminal 27 or 29 and on relay output 01 or 02.

4-53 Warning Speed High		
Range:		Function:
Size related*	[par. 4-52 - 60000 RPM]	Enter the n_{HIGH} value. When the motor speed exceeds this limit, the display reads <i>Speed High</i> . The signal outputs can be programmed to produce a status signal on terminal 27 or 29 and on relay output 01 or 02. Program the upper signal limit of the motor speed, n_{HIGH} , within the normal working range of the frequency converter.

4-54 Warning Reference Low		
Range:		Function:
-999999.999 *	[-999999.999 - par. 4-55]	Enter the lower reference limit. When the actual reference falls below this limit, the display indicates <i>RefLow</i> . The signal outputs can be programmed to produce a status signal on terminal 27 or 29 and on relay output 01 or 02.

4-55 Warning Reference High		
Range:		Function:
999999.999 *	[par. 4-54 - 999999.999]	Enter the upper reference limit. When the actual reference exceeds this limit, the display reads <i>Ref High</i> . The signal outputs can be programmed to produce a status signal on terminal 27 or 29 and on relay output 01 or 02.

4-56 Warning Feedback Low		
Range:		Function:
-999999.999 ReferenceFeed-backUnit*	[-999999.999 - par. 4-57 ReferenceFeed-backUnit]	Enter the lower feedback limit. When the feedback falls below this limit, the display reads <i>Feedb Low</i> . The signal outputs can be programmed to produce a status signal on terminal 27 or 29 and on relay output 01 or 02.

4-57 Warning Feedback High		
Range:		Function:
999999.999 ReferenceFeed-backUnit*	[par. 4-56 - 999999.999 ReferenceFeed-backUnit]	Enter the upper feedback limit. When the feedback exceeds this limit, the display reads <i>Feedb High</i> . The signal outputs can be programmed to produce a status signal on terminal 27 or 29 and on relay output 01 or 02.

4-58 Missing Motor Phase Function		
Displays alarm 30, 31 or 32 in the event of a missing motor phase. It is strongly recommended to enable to avoid motor damage.		
Option: Function:		
		NOTICE! This parameter cannot be adjusted while the motor is running.
[0]	Off	No alarm is displayed if a missing motor phase occurs.
[1]	On	

6.5.3 4-6* Speed Bypass

Some systems call for avoiding certain output frequencies or speeds, due to resonance problems in the system. A maximum of four frequency or speed ranges can be avoided.

4-60 Bypass Speed From [RPM]		
Array [4]		
Range:		Function:
Size related*	[0 - par. 4-13 RPM]	Some systems call for avoiding certain output speeds due to resonance problems in the system. Enter the lower limits of the speeds to be avoided.

4-61 Bypass Speed From [Hz]		
Array [4]		
Range:		Function:
Size related*	[0 - par. 4-14 Hz]	Some systems call for avoiding certain output speeds due to resonance problems in the system. Enter the lower limits of the speeds to be avoided.

4-62 Bypass Speed to [RPM]		
Array [4]		
Range:		Function:
Size related*	[0 - par. 4-13 RPM]	Some systems call for avoiding certain output speeds due to resonance problems in the system. Enter the upper limits of the speeds to be avoided.

4-63 Bypass Speed To [Hz]		
Array [4]		
Range:		Function:
Size related*	[0 - par. 4-14 Hz]	Some systems call for avoiding certain output speeds due to resonance problems in the system. Enter the upper limits of the speeds to be avoided.

6.6 Par. Group 5 - Digital In/Out

6.6.1 5-** Digital In/Out

Parameter group for configuring the digital input and output.

6.6.2 5-0* Digital In/Out Mode

5-00 Digital In/Out Mode

Option: Function:

		Digital inputs and programmed digital outputs are pre-programmable for operation either in PNP or NPN systems.
[0] *	PNP	Action on positive directional pulses.

5-00 Digital In/Out Mode

Option: Function:

[1]	NPN	
-----	-----	--

5-01 Terminal 27 Mode

Option: Function:

[0] *	Input	Defines terminal 27 as a digital input.
[1]	Output	Defines terminal 27 as a digital output.

NOTICE!

This parameter cannot be adjusted while the motor is running.

5-02 Terminal 29 Mode

Option: Function:

		Similar to Terminal 27
--	--	------------------------

6

6.6.3 5-1* Digital Inputs

Parameters for configuring the input functions for the input terminals.

The digital inputs are used for selecting various functions in the frequency converter. All digital inputs can be set to the following functions:

Digital input function	Select	Terminal
No operation	[0]	All *term 19, 29, 33
Reset	[1]	All *term 32
Coast inverse	[2]	All
Coast and reset inverse	[3]	All
Quick stop inverse	[4]	All
DC-brake inverse	[5]	All
Stop inverse	[6]	All *term 27
Start	[8]	All *term 18
Latched start	[9]	All
Reversing	[10]	All
Start reversing	[11]	All
Enable start forward	[12]	All
Enable start reverse	[13]	All
Jog	[14]	All
Preset reference on	[15]	All
Preset ref bit 0	[16]	All
Preset ref bit 1	[17]	All
Preset ref bit 2	[18]	All
Freeze reference	[19]	All
Freeze output	[20]	All
Speed up	[21]	All
Speed down	[22]	All
Set-up select bit 0	[23]	All
Set-up select bit 1	[24]	All
Catch up	[28]	All
Slow down	[29]	All
Pulse input	[32]	29, 33

Digital input function	Select	Terminal
Ramp bit 0	[34]	All
Ramp bit 1	[35]	All
Mains failure inverse	[36]	All
Day/night control	[39]	All
DigiPot Increase	[55]	All
DigiPot Decrease	[56]	All
DigiPot Clear	[57]	All
Counter A (up)	[60]	29, 33
Counter A (down)	[61]	29, 33
Reset Counter A	[62]	All
Counter B (up)	[63]	29, 33
Counter B (down)	[64]	29, 33
Reset Counter B	[65]	All
Lead pump start	[120]	All
Lead pump alternation	[121]	All
Comp. 1 Interlock	[130]	All
Comp. 2 Interlock	[131]	All
Comp. 3 Interlock	[132]	All
Comp. 1 Inv. interlock	[139]	All
Comp. 2 Inv. interlock	[140]	All
Comp. 3 Inv. interlock	[141]	All

Table 6.4 Overview of Digital Inputs

Functions dedicated to only one digital input are stated in the associated parameter.

All digital inputs can be programmed to these functions:

[0]	No operation	No reaction to signals transmitted to the terminal.
[1]	Reset	Resets frequency converter after a TRIP/ALARM. Not all alarms can be reset.
[2]	Coast inverse	(Default Digital input 27): Coasting stop, inverted input (NC). The frequency converter leaves the motor in free mode. Logic '0' ⇒ coasting stop.
[3]	Coast and reset inverse	Reset and coasting stop Inverted input (NC). Leaves motor in free mode and resets frequency converter. Logic '0' ⇒ coasting stop and reset.
[4]	Quick stop inverse	Inverted input (NC). Generates a stop in accordance with quick-stop ramp time set in <i>parameter 3-81 Quick Stop Ramp Time</i> . When motor stops, the shaft is in free mode. Logic '0' ⇒ Quick-stop.
[5]	DC-brake inverse	Inverted input for DC braking (NC). Stops motor by energizing it with a DC current for a certain time period. See <i>parameter 2-01 DC Brake Current</i> to <i>parameter 2-03 DC Brake Cut In Speed [RPM]</i> . The function is only active when the value in <i>parameter 2-02 DC Braking Time</i> is different from 0. Logic '0' ⇒ DC braking.

[6]	Stop inverse	Stop Inverted function. Generates a stop function when the selected terminal goes from logical level '1' to '0'. The stop is performed according to the selected ramp time (<i>parameter 3-42 Ramp 1 Ramp Down Time</i> , <i>parameter 3-52 Ramp 2 Ramp Down Time</i> , <i>parameter 3-62 Ramp 3 Ramp down Time</i> , <i>parameter 3-72 Ramp 4 Ramp Down Time</i>). NOTICE! When the frequency converter is at the torque limit and has received a stop command, it may not stop by itself. To ensure that the frequency converter stops, configure a digital output to [27] <i>Torque limit & stop</i> and connect this digital output to a digital input that is configured as coast.
[8]	Start	(Default Digital input 18): Select start for a start/stop command. Logic '1' = start, logic '0' = stop.
[9]	Latched start	The motor starts, if a pulse is applied for min. 2 ms. The motor stops when Stop inverse is activated.
[10]	Reversing	(Default Digital input 19). Change the direction of motor shaft rotation. Select Logic '1' to

		reverse. The reversing signal only changes the direction of rotation. It does not activate the start function. Select both directions in <i>parameter 4-10 Motor Speed Direction</i> . The function is not active in process closed loop.
[11]	Start reversing	Used for start/stop and for reversing on the same wire. Signals on start are not allowed at the same time.
[12]	Enable start forward	Rotates motor shaft clockwise at start.
[13]	Enable start reverse	Rotates motor shaft counterclockwise at start.
[14]	Jog	(Default Digital input 29): Use to activate jog speed. See <i>parameter 3-11 Jog Speed [Hz]</i> .
[15]	Preset reference on	Shifts between external reference and preset reference. It is assumed that [1] <i>External/preset</i> has been selected in <i>parameter 3-04 Reference Function</i> . Logic '0' = external reference active; logic '1' = one of the eight preset references is active.
[16]	Preset ref bit 0	Preset ref. bit 0,1, and 2 enables a choice between one of the eight preset references according to <i>Table 6.5</i> .
[17]	Preset ref bit 1	Same as Preset ref bit 0 [16].
[18]	Preset ref bit 2	Same as Preset ref bit 0 [16].

Preset ref. bit	2	1	0
Preset ref. 0	0	0	0
Preset ref. 1	0	0	1
Preset ref. 2	0	1	0
Preset ref. 3	0	1	1
Preset ref. 4	1	0	0
Preset ref. 5	1	0	1
Preset ref. 6	1	1	0
Preset ref. 7	1	1	1

Table 6.5 Reference Bits

[19]	Freeze ref	Freezes the actual reference, which is now the point of enable/condition for Speed up and Speed down to be used. If Speed up/down is used, the speed change always follows ramp 2 (<i>parameter 3-51 Ramp 2 Ramp Up Time</i> and <i>parameter 3-52 Ramp 2 Ramp Down Time</i>) in the range 0 - <i>parameter 3-03 Maximum Reference</i> .
[20]	Freeze output	Freezes the actual motor frequency (Hz), which is now the point of enable/condition for Speed up and Speed down to be used. If Speed up/down is used, the speed change always follows ramp 2 (<i>parameter 3-51 Ramp 2 Ramp Up Time</i> and

		<i>parameter 3-52 Ramp 2 Ramp Down Time</i>) in the range 0 to <i>parameter 1-23 Motor Frequency</i> . NOTICE! When Freeze output is active, the frequency converter cannot be stopped via a low [8] start signal. Stop the frequency converter via a terminal programmed for [2] <i>Coasting inverse</i> or [3] <i>Coast and reset, inverse</i> .
[21]	Speed up	Select Speed up and Speed down if digital control of the up/down speed is desired (motor potentiometer). Activate this function by selecting either Freeze reference or Freeze output. When Speed up/down is activated for less than 400 ms the resulting reference will be increased/ decreased by 0.1 %. If Speed up/ down is activated for more than 400 ms the resulting reference will follow the setting in ramping up/ down parameter 3-x1/ 3-x2.

	Shut down	Catch up
Unchanged speed	0	0
Reduced by %-value	1	0
Increased by %-value	0	1
Reduced by %-value	1	1

Table 6.6 Digital Speed Control

[22]	Speed down	Same as Speed up [21].
[23]	Set-up select bit 0	Select Set-up select bit 0 or Select Set-up select bit 1 to select one of the 4 set-ups. Set <i>parameter 0-10 Active Set-up</i> to Multi Set-up.
[24]	Set-up select bit 1	(Default Digital input 32): Same as [23] <i>Set-up select bit 0</i> .
[28]	Catch up	Increases or reduces reference value set in <i>parameter 3-12 Catch up/slow Down Value</i> .
[29]	Slow down	[28] <i>Same as Catch up</i> .
[30]	Counter input	Precise stop function in <i>parameter 1-83 Precise Stop Function</i> acts as Counter stop or speed compensated counter stop with or without reset. The counter value must be set in <i>parameter 1-84 Precise Stop Counter Value</i> .
[32]	Pulse input	Use pulse sequence as either reference or feedback. Scaling is done in parameter group 5-5* <i>Pulse Input</i> .
[34]	Ramp bit 0	Enables a choice between one of the 4 ramps available, according to <i>Table 6.7</i> .
[35]	Ramp bit 1	Same as [34] <i>Ramp bit 0</i> .

Preset ramp bit	1	0
Ramp 1	0	0
Ramp 2	0	1
Ramp 3	1	0
Ramp 4	1	1

Table 6.7 Ramp Bits

[36]	Mains failure inverse	Activates <i>parameter 14-10 Mains Failure</i> . Mains failure inverse is active in the Logic .0. situation.
[39]	Day/Night Control	Reduce the max. frequency with the setting in <i>parameter 28-74 Night Speed Drop [RPM]</i> .
[41]	Latched Precise Stop inverse	Sends a latched stop signal when the precise stop function is activated in <i>parameter 1-83 Precise Stop Function</i> . The Latched Precise stop inverse function is available for terminals 18 or 19.
[55]	DigiPot Increase	INCREASE signal to the Digital Potentiometer function described in parameter group 3-9* <i>Digital Potmeter</i> .
[56]	DigiPot Decrease	DECREASE signal to the Digital Potentiometer function described in parameter group 3-9* <i>Digital Potmeter</i>
[57]	DigiPot Clear	Clears the Digital Potentiometer reference described in parameter group 3-9* <i>Digital Potmeter</i>
[60]	Counter A	(Terminal 29 or 33 only) Input for increment counting in the SLC counter.
[61]	Counter A	(Terminal 29 or 33 only) Input for decrement counting in the SLC counter.
[62]	Reset Counter A	Input for reset of counter A.
[63]	Counter B	(Terminal 29 or 33 only) Input for increment counting in the SLC counter.
[64]	Counter B	(Terminal 29 or 33 only) Input for decrement counting in the SLC counter.
[65]	Reset Counter B	Input for reset of counter B.
[70]	Mech. Brake Feedback	Brake feedback for hoisting applications
[71]	Mech. Brake Feedback inv.	Inverted brake feedback for hoisting applications
[80]	PTC Card 1	All Digital Inputs can be set to [80] <i>PTC Card 1</i> . However, only one Digital Input must be set to this choice.
[121]	Lead Pump Alternation	
[130]	Compressor Interlock	Use with cascade controller. Logic 1 will stop the fixed speed compressor and give a warning

[131]	Compressor Interlock	Use with cascade controller. Logic 1 will stop the fixed speed compressor and give a warning
[132]	Compressor Interlock	Use with cascade controller. Logic 1 will stop the fixed speed compressor and give a warning

5-10 Terminal 18 Digital Input

Option: Function:

[8] *	Start	Functions are described under parameter group 5-1* <i>Digital Inputs</i>
-------	-------	--

5-11 Terminal 19 Digital Input

Option: Function:

[10] *	Reversing	Functions are described under parameter group 5-1* <i>Digital Inputs</i>
--------	-----------	--

5-12 Terminal 27 Digital Input

Option: Function:

[2] *	Coast inverse	Functions are described under parameter group 5-1* <i>Digital Inputs</i>
-------	---------------	--

5-13 Terminal 29 Digital Input

Option: Function:

		Select the function from the available digital input range and the additional options [60], [61], [63] and [64]. Counters are used in Smart Logic Control functions.
[14] *	Jog	
[60]	Counter A (up)	
[61]	Counter A (down)	
[63]	Counter B (up)	
[64]	Counter B (down)	

5-14 Terminal 32 Digital Input

Option: Function:

		Select the function from the available digital input range.
	No operation	Functions are described under 5-1* <i>Digital Inputs</i>

5-15 Terminal 33 Digital Input

Option: Function:

		Select the function from the available digital input range and the additional options [60], [61], [63] and [64]. Counters are used in Smart Logic Control functions.
[0] *	No operation	Functions are described under 5-1* <i>Digital Inputs</i>

5-19 Terminal 37 Safe Stop

Option: Function:

[1]	Safe Stop Alarm	
[3]	Safe Stop Warning	

5-19 Terminal 37 Safe Stop		
Option:		Function:
[4]	PTC 1 Alarm	
[5]	PTC 1 Warning	
[6]	PTC 1 & Relay A	
[7]	PTC 1 & Relay W	
[8]	PTC 1 & Relay A/W	
[9]	PTC 1 & Relay W/A	

6.6.4 5-3* Digital Outputs

Parameters for configuring the output functions for the output terminals. The 2 solid-state digital outputs are common for terminals 27 and 29. Set the I/O function for terminal 27 in *parameter 5-01 Terminal 27 Mode*, and set the I/O function for terminal 29 in *parameter 5-02 Terminal 29 Mode*. Digital outputs appear if *parameter 5-01 Terminal 27 Mode* or *parameter 5-02 Terminal 29 Mode* are set to output.

NOTICE!

These parameters cannot be adjusted while the motor is running.

NOTICE!

Only for activating 24 V DC devices – restricted use for relays.

		The digital outputs can be programmed with these functions:
[0]	No operation	<i>Default for all digital outputs and relay outputs</i>
[1]	Control ready	The control board receives supply voltage.
[2]	Drive ready	The frequency converter is ready for operation and applies a supply signal on the control board.
[3]	Drive ready / remote control	The frequency converter is ready for operation and is in Auto On mode.
[4]	Stand-by / no warning	The frequency converter is ready for operation. No start or stop command is been given (start/disable). There are no warnings.
[5]	Running	The motor is running.
[6]	Running / no warning	The output speed is higher than the speed set in <i>parameter 1-81 Min Speed for Function at Stop [RPM]</i> . The motor is running and there are no warnings.
[7]	Run on reference / no warning	The motor runs at reference speed.

[8]	Run in range / no warning	The motor runs in speed range.
[9]	Alarm	An alarm activates the output. There are no warnings.
[10]	Alarm or warning	An alarm or a warning activates the output.
[11]	At torque limit	The torque limit set in <i>parameter 4-16 Torque Limit Motor Mode</i> or <i>parameter 1-17 Voltage filter time const.</i> has been exceeded.
[12]	Out of current range	The motor current is outside the range set in <i>parameter 4-18 Current Limit</i> .
[13]	Below current, low	The motor current is lower than set in <i>parameter 4-50 Warning Current Low</i> .
[14]	Above current, high	The motor current is higher than set in <i>parameter 4-51 Warning Current High</i> .
[15]	Out of speed range	The output speed is outside the range set in <i>parameter 4-52 Warning Speed Low</i> and <i>parameter 4-53 Warning Speed High</i> .
[16]	Below speed, low	The output speed is lower than the setting in <i>parameter 4-52 Warning Speed Low</i> .
[17]	Above speed, high	The output speed is higher than the setting in <i>parameter 4-53 Warning Speed High</i> .
[18]	Out of feedback	The feedback is outside the range set in <i>parameter 4-56 Warning Feedback Low</i> and <i>parameter 4-57 Warning Feedback High</i> .
[19]	Below feedback low	The feedback is below the limit set in <i>parameter 4-56 Warning Feedback Low</i> .
[20]	Above feedback high	The feedback is above the limit set in <i>parameter 4-57 Warning Feedback High</i> .
[21]	Thermal warning	The thermal warning turns on when the temperature exceeds the limit in the motor, the frequency converter, the brake resistor, or the thermistor.
[25]	Reverse	<i>Reversing. Logic '1' = relay activated, 24 V DC when CW rotation of the motor. Logic '0' = relay not activated, no signal, when CCW rotation of the motor.</i>
[26]	Bus OK	Active communication (no time-out) via the serial communication port.
[27]	Torque limit and stop	Use in performing a coasting stop and in torque limit condition. If the frequency converter has received a stop signal and is at the torque limit, the signal is Logic '0'.
[28]	Brake, no warning	The brake is active and there are no warnings.
[29]	Brake ready, no fault	The brake is ready for operation and there are no faults.
[30]	Brake fault (IGBT)	The output is Logic '1' when the brake IGBT is short-circuited. Use this function to

		protect the frequency converter if there is a fault on the brake modules. Use the output/relay to cut out the main voltage from the frequency converter.
[33]	Safe Stop Active	Indicates that the safe stop on terminal 37 is active.
[35]	External Interlock	External Interlock function has been activated via one of the digital inputs.
[40]	Out of ref range	Active when the actual speed is outside the settings in <i>parameter 4-52 Warning Speed Low</i> to <i>parameter 4-55 Warning Reference High</i> .
[41]	Below reference low	Active when the actual speed is below the speed reference setting.
[42]	Above reference high	Active when the actual speed is above the speed reference setting.
[45]	Bus Ctrl	Control output via bus. The state of the output is set in <i>parameter 5-90 Digital & Relay Bus Control</i> . The output state is retained in the event of bus time-out.
[46]	Bus Ctrl 1 if timeout	Controls output via bus. The state of the output is set in <i>parameter 5-90 Digital & Relay Bus Control</i> . In the event of bus time-out the output state is set low (On).
[47]	Bus Ctrl 0 if timeout	Controls output via bus. The state of the output is set in <i>parameter 5-90 Digital & Relay Bus Control</i> . In the event of bus time-out the output state is set low (Off).
[55]	Pulse output	
[60]	Comparator 0	See parameter group <i>13-1* Comparators</i> . If Comparator 0 is evaluated as TRUE, the output will go high. Otherwise, it will be low.
[61]	Comparator 1	See parameter group <i>13-1* Comparators</i> . If Comparator 2 is evaluated as TRUE, the output will go high. Otherwise, it will be low.
[62]	Comparator 2	See parameter group <i>13-1* Comparators</i> . If Comparator 2 is evaluated as TRUE, the output will go high. Otherwise, it will be low.
[63]	Comparator 3	See parameter group <i>13-1* Comparators</i> . If Comparator 3 is evaluated as TRUE, the output will go high. Otherwise, it will be low.
[64]	Comparator 4	See parameter group <i>13-1* Comparators</i> . If Comparator 4 is evaluated as TRUE, the output will go high. Otherwise, it will be low.
[65]	Comparator 5	See parameter group <i>13-1* Comparators</i> . If Comparator 4 is evaluated as TRUE, the output will go high. Otherwise, it will be low.

[70]	Logic Rule 0	See parameter group <i>13-4* Logic Rules</i> . If Logic Rule 0 is evaluated as TRUE, the output will go high. Otherwise, it will be low.
[71]	Logic Rule 1	See parameter group <i>13-4* Logic Rules</i> . If Logic Rule 1 is evaluated as TRUE, the output will go high. Otherwise, it will be low.
[72]	Logic Rule 2	See parameter group <i>13-4* Logic Rules</i> . If Logic Rule 2 is evaluated as TRUE, the output will go high. Otherwise, it will be low.
[73]	Logic Rule 3	See parameter group <i>13-4* Logic Rules</i> . If Logic Rule 3 is evaluated as TRUE, the output will go high. Otherwise, it will be low.
[74]	Logic Rule 4	See parameter group <i>13-4* Logic Rules</i> . If Logic Rule 4 is evaluated as TRUE, the output will go high. Otherwise, it will be low.
[75]	Logic Rule 5	See parameter group <i>13-4* Logic Rules</i> . If Logic Rule 5 is evaluated as TRUE, the output will go high. Otherwise, it will be low.
[80]	SL Digital Output A	See <i>parameter 13-52 SL Controller Action</i> . The input will go high whenever the Smart Logic Action [38] <i>Set dig. out. A high</i> is executed. The input will go low whenever the Smart Logic Action [32] <i>Set dig. out. A low</i> is executed.
[81]	SL Digital Output B	See <i>parameter 13-52 SL Controller Action</i> . The input will go high whenever the Smart Logic Action [39] <i>Set dig. out. A high</i> is executed. The input will go low whenever the Smart Logic Action [33] <i>Set dig. out. A low</i> is executed.
[82]	SL Digital Output C	See <i>parameter 13-52 SL Controller Action</i> . The input will go high whenever the Smart Logic Action [40] <i>Set dig. out. A high</i> is executed. The input will go low whenever the Smart Logic Action [34] <i>Set dig. out. A low</i> is executed.
[83]	SL Digital Output D	See <i>parameter 13-52 SL Controller Action</i> . The input will go high whenever the Smart Logic Action [41] <i>Set dig. out. A high</i> is executed. The input will go low whenever the Smart Logic Action [35] <i>Set dig. out. A low</i> is executed.
[84]	SL Digital Output E	See <i>parameter 13-52 SL Controller Action</i> . The input will go high whenever the Smart Logic Action [42] <i>Set dig. out. A high</i> is executed. The input will go low whenever the Smart Logic Action [36] <i>Set dig. out. A low</i> is executed.

[85]	SL Digital Output F	See <i>parameter 13-52 SL Controller Action</i> . The input will go high whenever the Smart Logic Action [43] Set dig. out. A high is executed. The input will go low whenever the Smart Logic Action [37] Set dig. out. A low is executed.
[122]	No alarm	The output is high when no alarm is present.
[123]	Start command active	The output is high when there is an active Start command (i.e. via digital input bus connection or [Hand on] or [Auto on]), and no Stop or Start command is active.
[124]	Running reverse	The output is high when the frequency converter is running counter clockwise (the logical product of the status bits 'running' AND 'reverse').
[125]	Drive in hand mode	The output is high when the frequency converter is in Hand on mode (as indicated by the LED light above [Hand on]).
[126]	Drive in auto mode	The output is high when the frequency converter is in Hand on mode (as indicated by the LED light above [Auto on]).
[139]	Compressor Inv. Interlock	Use with cascade controller. Logic will stop the fixed speed compressor and give a warning.
[140]	Compressor Inv. Interlock	Use with cascade controller. Logic will stop the fixed speed compressor and give a warning.
[141]	Compressor Inv. Interlock	Use with cascade controller. Logic will stop the fixed speed compressor and give a warning.
[195]	Bypass Valve Control	The bypass valve control (Digital/Relay output in the frequency converter) is used for compressor systems to unload the compressor during start-up by using a bypass valve. After the start command is given the bypass valve will be open until the frequency converter reaches <i>parameter 4-11 Motor Speed Low Limit [RPM]</i> . After the limit has been reached the bypass valve will be closed, allowing the compressor to operate normally. This procedure will not be activated again before a new start is initiated and the frequency converter speed is zero during the receiving of start signal. <i>Parameter 1-71 Start Delay</i> can be used in order to delay the motor start. The bypass valve control principle:

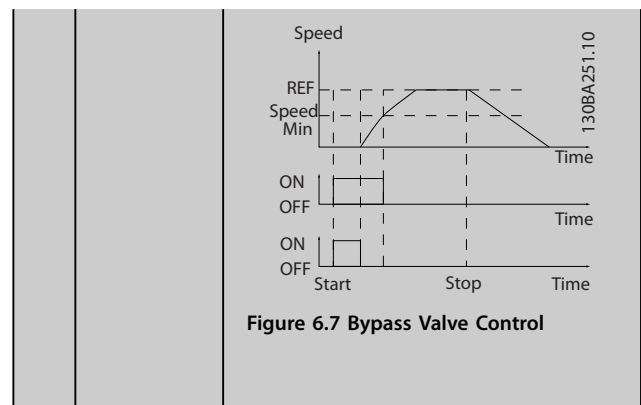

The below setting options are all related to the Cascade Controller. Wiring diagrams and settings for parameter, see parameter group 25-** *Cascade Pack Controller* or more details.

6.6.5 5-4* Relays (Dry Contacts)

NOTICE!

Relays 7, 8, and 9 are only available if MCB 105 relay card is installed.

NOTICE!

Relay 1 is dedicated to controlling the solenoid valve.

Parameters for configuring the timing and the output functions for the relays.

5-40 Function Relay

Array [8] (Relay 1 [0], Relay 2 [1], Relay 7 [6], Relay 8 [7], Relay 9 [8])

[0]	No Operation
[1]	Control Ready
[2]	Drive Ready
[3]	Drive Ready/Remote
[4]	Stand-by/No Warning
[5] *	Running
[6]	Running/No Warning
[8]	Run on Ref./No Warning
[9]	Alarm
[10]	Alarm or Warning
[11]	At Torque Limit
[12]	Out of Current Range
[13]	Below Current, low
[14]	Above Current, high
[15]	Out of Speed Range
[16]	Below Speed, low
[17]	Above Speed, high
[18]	Out of Feedb. Range

[19]	Below Feedback, low	
[20]	Above Feedback, high	
[21]	Thermal Warning	
[22]	Ready, no thermal w	
[25]	Reverse	
[26]	Bus OK	
[27]	Torque Limit & Stop	
[28]	Brake, No Warning	
[29]	Brake Ready, No Fault	
[30]	Brake Fault (IGBT)	
[31]	Relay 123	
[32]	Mech brake ctrl	
[33]	Safe stop active	
[35]	External Interlock	
[36]	Control Word Bit 11	
[37]	Control Word Bit 12	
[40]	Out of Ref. Range	
[41]	Below Reference, low	
[42]	Above Ref. high	
[45]	Bus ctrl	
[46]	Bus ctrl, 1 if timeout	
[47]	Bus ctrl, 0 if timeout	
[60]	Comparator 0	
[61]	Comparator 1	
[62]	Comparator 2	
[63]	Comparator 3	
[64]	Comparator 4	
[65]	Comparator 5	
[70]	Logic Rule 0	
[71]	Logic Rule 1	
[72]	Logic Rule 2	
[73]	Logic Rule 3	
[74]	Logic Rule 4	
[75]	Logic Rule 5	
[80]	SL Digital Output A	
[81]	SL Digital Output B	
[82]	SL Digital Output C	
[83]	SL Digital Output D	
[84]	SL Digital Output E	
[85]	SL Digital Output F	
[120]	Local Ref. Active	
[121]	Remote Ref. Active	
[122]	No Alarm	
[123]	Start Cmd. Active	
[124]	Running Reverse	
[125]	Drive in Hand Mode	
[126]	Drive in Auto Mode	
[195]	Bypass Valve Control	
[211]	Cascade Compressor 1	
[212]	Cascade Compressor 2	
[213]	Cascade Compressor 3	

5-50 Term. 29 Low Frequency		
Range:		Function:
100 Hz*	[0 - 110000 Hz]	Enter the low frequency limit corresponding to the low motor shaft speed (i.e. low reference value) in <i>parameter 5-52 Term. 29 Low Ref./Feedb. Value</i> . Refer to the diagram in this section.

5-51 Term. 29 High Frequency		
Range:		Function:
100 Hz*	[0 - 110000 Hz]	Enter the high frequency limit corresponding to the high motor shaft speed (i.e. high reference value) in <i>parameter 5-53 Term. 29 High Ref./Feedb. Value</i> .

5-52 Term. 29 Low Ref./Feedb. Value		
Range:		Function:
0 ReferenceFeed-backUnit*	[-999999.999 - 999999.999 ReferenceFeed-backUnit]	Enter the low reference value limit for the motor shaft speed [RPM]. This is also the lowest feedback value, see also <i>parameter 5-57 Term. 33 Low Ref./Feedb. Value</i> . Set terminal 29 to digital input (<i>parameter 5-02 Terminal 29 Mode = [0] input (default)</i> and <i>parameter 5-13 Terminal 29 Digital Input = applicable value</i>).

5-53 Term. 29 High Ref./Feedb. Value		
Range:		Function:
Size related*	[-999999.999 - 999999.999 ReferenceFeed-backUnit]	Enter the high reference value [RPM] for the motor shaft speed and the high feedback value, see also <i>parameter 5-58 Term. 33 High Ref./Feedb. Value</i> . Select terminal 29 as a digital input (<i>parameter 5-02 Terminal 29 Mode = [0] input (default)</i> and <i>parameter 5-13 Terminal 29 Digital Input = applicable value</i>).

5-54 Pulse Filter Time Constant #29		
Range:		Function:
100 ms*	[1 - 1000 ms]	Enter the pulse filter time constant. The pulse filter dampens oscillations of the feedback signal, which is an advantage if there is a lot of noise in the system. A high time constant value results in better

5-54 Pulse Filter Time Constant #29		
Range:	Function:	
	dampening but also increases the time delay through the filter.	

5-55 Term. 33 Low Frequency		
Range:	Function:	
100 Hz* [0 - 110000 Hz]	Enter the low frequency corresponding to the low motor shaft speed (i.e. low reference value) in <i>parameter 5-57 Term. 33 Low Ref./Feedb. Value</i> .	

5-56 Term. 33 High Frequency		
Range:	Function:	
100 Hz* [0 - 110000 Hz]	Enter the high frequency corresponding to the high motor shaft speed (i.e. high reference value) in <i>parameter 5-58 Term. 33 High Ref./Feedb. Value</i> .	

5-57 Term. 33 Low Ref./Feedb. Value		
Range:	Function:	
0 * [-999999.999 - 999999.999]	Enter the low reference value [RPM] for the motor shaft speed. This is also the low feedback value, see also <i>parameter 5-52 Term. 29 Low Ref./Feedb. Value</i> .	

5-58 Term. 33 High Ref./Feedb. Value		
Range:	Function:	
Size related* [-999999.999 - 999999.999 ReferenceFeed-backUnit]	Enter the high reference value [RPM] for the motor shaft speed. See also <i>parameter 5-53 Term. 29 High Ref./Feedb. Value</i> .	

5-59 Pulse Filter Time Constant #33		
Range:	Function:	
100 ms* [1 - 1000 ms]	Enter the pulse filter time constant. The low-pass filter reduces the influence on and dampens oscillations on the feedback signal from the control. This is an advantage, e.g. if there is a great amount on noise in the system.	

5-60 Terminal 27 Pulse Output Variable		
Option:	Function:	
[0]	No operation	Select the desired display output for terminal 27.
[45]	Bus ctrl.	
[48]	Bus ctrl., timeout	
[51]	MCO controlled	

5-60 Terminal 27 Pulse Output Variable		
Option:	Function:	
[100]	Output frequency	
[101]	Reference	
[102]	Feedback	
[103]	Motor current	
[104]	Torque rel to limit	
[105]	Torq relate to rated	
[106]	Power	
[107]	Speed	
[108]	Torque	
[109]	Max Out Freq	
[119]	Torque % lim	

5-62 Pulse Output Max Freq #27		
Range:	Function:	
Size related* [0 - 32000 Hz]	Set the maximum frequency for terminal 27, corresponding to the output variable selected in <i>parameter 5-60 Terminal 27 Pulse Output Variable</i> .	

5-63 Terminal 29 Pulse Output Variable		
Option:	Function:	
[0]	No operation	Select the desired display output for terminal 29.
[45]	Bus ctrl.	
[48]	Bus ctrl., timeout	
[51]	MCO controlled	
[100]	Output frequency	
[101]	Reference	
[102]	Feedback	
[103]	Motor Current	
[104]	Torque rel to limit	
[105]	Torq relate to rated	
[106]	Power	
[107]	Speed	
[108]	Torque	
[109]	Max Out Freq	

5-65 Pulse Output Max Freq #29		
Range:	Function:	
5000 Hz*	[0 - 32000 Hz]	Set the maximum frequency for terminal 29 corresponding to the output variable set in <i>parameter 5-63 Terminal 29 Pulse Output Variable</i> .

5-90 Digital & Relay Bus Control		
Range:	Function:	
0 * [0 - 2147483647]	This parameter holds the state of the digital outputs and relays that is controlled by bus. A logical '1' indicates that the output is high or active. A logical '0' indicates that the output is low or inactive.	

Bit 0	Digital Output Terminal 27
Bit 1	Digital Output Terminal 29
Bit 2	Digital Output Terminal X 30/6
Bit 3	Digital Output Terminal X 30/7
Bit 4	Relay 1 output terminal
Bit 5	Relay 2 output terminal
Bit 6	Option B Relay 1 output terminal
Bit 7	Option B Relay 2 output terminal
Bit 8	Option B Relay 3 output terminal
Bit 9-15	Reserved for future terminals
Bit 16	Option C Relay 1 output terminal
Bit 17	Option C Relay 2 output terminal
Bit 18	Option C Relay 3 output terminal
Bit 19	Option C Relay 4 output terminal
Bit 20	Option C Relay 5 output terminal
Bit 21	Option C Relay 6 output terminal
Bit 22	Option C Relay 7 output terminal
Bit 23	Option C Relay 8 output terminal
Bit 24-31	Reserved for future terminals

Table 6.8 Bus-controlled Digital Outputs and Relays

5-93 Pulse Out #27 Bus Control		
Range:	Function:	
0 %* [0 - 100 %]	Set the output frequency transferred to the output terminal 27 when the terminal is configured as [45] Bus Controlled in parameter 5-60 Terminal 27 Pulse Output Variable.	

5-95 Pulse Out #29 Bus Control		
Range:	Function:	
0 %* [0 - 100 %]	Set the output frequency transferred to the output terminal 29 when the terminal is configured as [45] Bus Controlled in parameter 5-63 Terminal 29 Pulse Output Variable.	

6.7 Par. Group 6 - Analog In/Out

Parameter group for configuration of the analog input and output.

6.7.1 6-0* Analog In/Out Mode

Parameter group for setting up the analog In/Out configuration.

The frequency converter is equipped with 2 analog inputs: Terminal 53 and 54. The analog inputs on the frequency converter can freely be allocated to either voltage (-10 V to +10 V) or current input (0/4 to 20 mA).

6-00 Live Zero Timeout Time		
Range:	Function:	
10 s*	[1 - 99 s]	Enter the Live Zero Time-out time period. Live Zero Time-out Time is active for analog inputs, i.e. terminal 53 or terminal 54, used as reference or feedback sources. If the reference signal value associated with the selected current input falls below 50% of the value set in <i>parameter 6-10 Terminal 53 Low Voltage</i> , <i>parameter 6-12 Terminal 53 Low Current</i> , <i>parameter 6-20 Terminal 54 Low Voltage</i> or <i>parameter 6-22 Terminal 54 Low Current</i> for a time period longer than the time set in <i>parameter 6-00 Live Zero Timeout Time</i> , the function selected in <i>parameter 6-01 Live Zero Timeout Function</i> will be activated.

6-01 Live Zero Timeout Function		
Option:	Function:	
		Select the time-out function. The function set in <i>parameter 6-01 Live Zero Timeout Function</i> will be activated if the input signal on terminal 53 or 54 is below 50% of the value in <i>parameter 6-10 Terminal 53 Low Voltage</i> , <i>parameter 6-12 Terminal 53 Low Current</i> , <i>parameter 6-20 Terminal 54 Low Voltage</i> or <i>parameter 6-22 Terminal 54 Low Current</i> for a time period defined in <i>parameter 6-00 Live Zero Timeout Time</i> . If several time-outs occur simultaneously, the frequency converter prioritizes the time-out functions as follows: <ol style="list-style-type: none"> <i>Parameter 6-01 Live Zero Timeout Function</i> <i>Parameter 8-04 Control Word Timeout Function</i>
[1]	Freeze Output	Frozen at the present value
[0] *	Off	

6-01 Live Zero Timeout Function		
Option:	Function:	
[1]	Freeze output	Frozen at the present value
[2]	Stop	Overruled to stop
[3]	Jogging	Overruled to jog speed
[4]	Max. speed	Overruled to max. speed
[5]	Stop and trip	Overruled to stop with subsequent trip

6.7.2 6-1* Analog Input 1

Parameters for configuring the scaling and limits for analog input 1 (terminal 53).

NOTICE!

Analog input 53 is preset for usage with "Open Loop" control on 0-10 V. Terminal 54 is preset for "Process Loop" control using a pressure sensor AKS with a pressure range of -14 : 174 psi.

6-10 Terminal 53 Low Voltage		
Range:	Function:	
0.00V*	[-10.0 - par. 6-11]	This analog input scaling value should correspond to the minimum reference value, set in <i>parameter 3-02 Minimum Reference</i> .

6-11 Terminal 53 High Voltage		
Range:	Function:	
10.00 V*	[6-10 to 10 V]	This analog input scaling value should correspond to the maximum reference value, set in par. 3-03.

6-12 Terminal 53 Low Current		
Range:	Function:	
4.0mA*	[0.0 to par. 6-13 mA]	This reference signal should correspond to the minimum reference value, set in <i>parameter 3-02 Minimum Reference</i> .

6-13 Terminal 53 High Current		
Range:	Function:	
20.0mA*	[6-12 to 20 mA]	This reference signal should correspond to the maximum reference value, set in <i>parameter 3-02 Minimum Reference</i> .

6-14 Terminal 53 Low Ref./Feedb. Value		
Range:	Function:	
Size related*	[Enter the analog input scaling value that corresponds to the low voltage/low current set in <i>parameter 6-10 Terminal 53</i>	

6-14 Terminal 53 Low Ref./Feedb. Value

Range:	Function:
[Low Voltage and parameter 6-12 Terminal 53 Low Current.]	

6-15 Terminal 53 High Ref./Feedb. Value

Range:	Function:
Size related* []	Enter the analog input scaling value that corresponds to the maximum reference feedback value set in <i>parameter 6-11 Terminal 53 High Voltage</i> and <i>parameter 6-13 Terminal 53 High Current</i> .

3-72 Ramp 4 Ramp-down Time

Range:	Function:
Size related* [0.01 - 3600 s]	Enter the ramp-down time, i.e. the deceleration time from the rated motor speed n_s to 0 RPM. Choose a ramp-down time such that no over-voltage arises in the inverter due to regenerative operation of the motor, and such that the generated current does not exceed the current limit set in <i>parameter 4-18 Current Limit</i> . The value 0.00 corresponds to 0.01 s in speed mode. See ramp-up time in <i>parameter 3-71 Ramp 4 Ramp-up Time</i> .
	$Par. 3 - 72 = \frac{t_{dec} [s] \times n_s [RPM]}{ref [RPM]}$

6.7.3 6-2* Analog Input 2

Parameters for configuring the scaling and limits for analog input 2 (terminal 54).

NOTICE!

Analog input 53 is preset for usage with "open loop" control on 0-10 V. Terminal 54 is preset for "Process Loop" control using a pressure sensor AKS with a pressure range of -1 : 12 bar.

6-20 Terminal 54 Low Voltage

Range:	Function:
1.00V* [-10.0 - par. 6-11]	This analog input scaling value should correspond to the minimum output value of the pressure sensor

6-21 Terminal 54 High Voltage

Range:	Function:
5.00V* [6-10 to 10 V]	This analog input scaling value should correspond to the maximum output value of the pressure sensor.

6-22 Terminal 54 Low Current

Range:	Function:
4.0mA * [0.0 to par. 6-13 mA]	This reference signal should correspond to the minimum output value of the pressure sensor.

6-23 Terminal 54 High Current

Range:	Function:
20.0mA * [6-12 to 20 mA]	This reference signal should correspond to the maximum output value of the pressure sensor.

6-24 Terminal 54 Low Ref./Feedb.

Range:	Function:
-1 (bar) [Value]	Enter the analog input scaling value that corresponds to the minimum reference feedback value set in <i>parameter 3-02 Minimum Reference</i> .

6-25 Terminal 54 High Ref./Feedb.

Range:	Function:
12 (bar) [Value]	Enter the analog input scaling value that corresponds to the maximum reference feedback value set in <i>parameter 3-03 Maximum Reference</i> .

6-26 Terminal 54 Filter Time Constant

Range:	Function:
0.001 s* [0.001 - 10 s]	<p>NOTICE!</p> <p>This parameter cannot be adjusted while the motor is running.</p> <p>Enter the time constant. This is a first-order digital low pass filter time constant for suppressing electrical noise in terminal 54. A high time constant value improves dampening but also increases the time delay through the filter.</p>

6-50 Terminal 42 Output

Option:	Function:
	Select the function of Terminal 42 as an analog current output. Depending on the selection the output is either a 0-20 mA or 4-20 mA output. The current value can be read out in LCP in <i>parameter 16-65 Analog Output 42 [mA]</i> .
[0]	No operation There is no signal on the analog output.
[100]	Output frequency 0-20 mA 0 Hz = 0 mA; 100 Hz = 20 mA.
[101]	Reference 0-20 mA <i>parameter 3-00 Reference Range [Min - Max]</i> 0% = 0 mA; 100% = 20 mA

6-50 Terminal 42 Output

Option:	Function:
	<i>parameter 3-00 Reference Range [-Max - Max]</i> -100% = 0 mA; 0% = 10 mA; +100% = 20 mA
[103] Motor current 0-20 mA	Value is taken from <i>parameter 16-37 Inv. Max. Current</i> . Inverter max. current (160% current) is equal to 20 mA. Example: Inverter norm current (11 kW) = 24 A. 160% = 38.4 A. Motor norm current = 22 A Read-out 11.46 mA. $\frac{20 \text{ mA} \times 22 \text{ A}}{38.4 \text{ A}} = 11.46 \text{ mA}$ In case the norm motor current is equal to 20 mA, the output setting of <i>parameter 6-52 Terminal 42 Output Max Scale</i> is: $\frac{I_{VLT_{max}} \times 100}{I_{Motor_{norm}}} = \frac{38.4 \times 100}{22} = 175\%$
[104] Torque rel to lim 0-20 mA	The torque setting is related to setting in <i>parameter 4-16 Torque Limit Motor Mode</i>
[105] Torque rel to rated motor torque 0-20 mA	The torque is related to the motor torque setting.
[106] Power 0-20 mA	Taken from <i>parameter 1-20 Motor Power [kW]</i> .
[107] Speed 0-20 mA	Taken from <i>parameter 3-03 Maximum Reference</i> . 20 mA = value in <i>parameter 3-03 Maximum Reference</i>
[108] Torque ref. 0-20 mA	Torque reference related to 160% torque.
[109] Max Out Freq 0-20 mA	In relation to <i>parameter 4-19 Max Output Frequency</i> .
[134] Torque% lim. 4-20 mA	The torque setting is related to setting in <i>parameter 4-16 Torque Limit Motor Mode</i> .
[135] Torque% nom 4-20 mA	The torque setting is related to the motor torque setting.
[141] Bus ctrl. 0-20 mA, timeout	<i>parameter 4-54 Warning Reference Low</i> defines the behavior of the analog output in case of bus time-out.
[142] Bus ctrl. 4-20 mA, timeout	<i>parameter 4-54 Warning Reference Low</i> defines the behavior of the analog output in case of bus time-out.
[150] Max Out Freq 4-20 mA	In relation to <i>parameter 4-19 Max Output Frequency</i> .
[119] Torque % lim	
[149] Torque % lim 4-20mA	Analog output at zero torque = 12 mA. Motoric torque will increase the output

6-50 Terminal 42 Output

Option:	Function:
	current to max torque limit 20 mA (set in <i>parameter 4-16 Torque Limit Motor Mode</i>). Generative torque will decrease the output to torque limit Generator Mode (set in <i>parameter 4-17 Torque Limit Generator Mode</i>) Ex: <i>parameter 4-16 Torque Limit Motor Mode</i> : 200% and <i>parameter 4-17 Torque Limit Generator Mode</i> : 200%. 20 mA = 200% Motoric and 4 mA = 200% Generatoric. Figure 6.8
[0] *	No operation When no signal on the analog output.
[52] MCO 0-20mA	
[53] MCO 4-20mA	
[100] Output frequency	0 Hz = 0 mA; 100 Hz = 20 mA.
[101] Reference	<i>Parameter 3-00 Reference Range [Min - Max]</i> 0% = 0 mA; 100% = 20 mA <i>Parameter 3-00 Reference Range [-Max - Max]</i> -100% = 0 mA; 0% = 10 mA; +100% = 20 mA
[102] Feedback	
[103] Motor current	Value is taken from <i>parameter 16-37 Inv. Max. Current</i> . Inverter max. current (160% current) is equal to 20 mA. Example: Inverter norm current (11 kW) = 24 A. 160% = 38.4 A. Motor norm current = 22A Read-out 11.46 mA. $\frac{I_{VLT_{max}} \times 100}{I_{Motor_{norm}}} = \frac{38.4 \times 100}{22} = 175\%$ In case the norm motor current is equal to 20 mA, the output setting of <i>parameter 6-52 Terminal 42 Output Max Scale</i> is: $\frac{I_{VLT_{max}} \times 100}{I_{Motor_{norm}}} = \frac{38.4 \times 100}{22} = 175\%$
[104] Torque rel to limit	The torque setting is related to setting in <i>parameter 4-16 Torque Limit Motor Mode</i>
[105] Torq relate to rated	The torque is related to the motor torque setting.
[106] Power	Taken from <i>parameter 1-20 Motor Power [kW]</i> .
[107] Speed	Taken from <i>parameter 3-03 Maximum Reference</i> . 20 mA = value in <i>parameter 3-03 Maximum Reference</i>

6-50 Terminal 42 Output		
Option:	Function:	
[108] Torque	Torque reference related to 160% torque.	
[109] Max Out Freq	0 Hz = 0 mA, <i>parameter 4-19 Max Output Frequency</i> = 20 mA.	
[130] Output freq. 4-20mA	0 Hz = 4 mA, 100 Hz = 20 mA	
[131] Reference 4-20mA	<i>Parameter 3-00 Reference Range [Min-Max]</i> 0% = 4 mA; 100% = 20 mA <i>Parameter 3-00 Reference Range [-Max-Max]</i> -100% = 4 mA; 0% = 12 mA; +100% = 20 mA	
[132] Feedback 4-20mA		
[133] Motor cur. 4-20mA	Value is taken from <i>parameter 16-37 Inv. Max. Current</i> . Inverter max. current (160% current) is equal to 20 mA. Example: Inverter norm current (11 kW) = 24 A. 160% = 38.4 A. Motor norm current = 22 A Read-out 11.46 mA. $\frac{16 \text{ mA} \times 22 \text{ A}}{38.4 \text{ A}} + 4 \text{ mA} = 13.17 \text{ mA}$ In case the norm motor current is equal to 20 mA, the output setting of <i>parameter 6-62 Terminal X30/8 Max. Scale</i> is: $\frac{I_{VLT \text{ Max.}} \times 100}{I_{Motor \text{ Norm}}} = \frac{38.4 \times 100}{22} = 175\%$	
[134] Torq.% lim 4-20 mA	The torque setting is related to setting in <i>parameter 4-16 Torque Limit Motor Mode</i> .	
[135] Torq.% nom 4-20 mA	The torque setting is related to the motor torque setting.	
[136] Power 4-20mA	Taken from <i>parameter 1-20 Motor Power [kW]</i>	
[137] Speed 4-20mA	Taken from <i>parameter 3-03 Maximum Reference</i> . 20 mA = Value in <i>parameter 3-03 Maximum Reference</i> .	
[138] Torque 4-20mA	Torque reference related to 160% torque.	
[139] Bus ctrl. 0-20 mA	An output value set from fieldbus process data. The output will work independently of internal functions in the frequency converter.	
[140] Bus ctrl. 4-20 mA	An output value set from fieldbus process data. The output will work independently of internal functions in the frequency converter.	
[141] Bus ctrl 0-20mA t.o.	<i>Parameter 4-54 Warning Reference Low</i> defines the behavior of the analog output in case of bus time-out.	
[142] Bus ctrl 4-20mA t.o.	<i>Parameter 4-54 Warning Reference Low</i> defines the behavior of the analog output in case of bus time-out.	
[150] Max Out Fr 4-20mA	0 Hz = 0 mA, <i>parameter 4-19 Max Output Frequency</i> = 20 mA.	

6-51 Terminal 42 Output Min Scale		
Range:	Function:	
0 %* [0 - 200 %]	Scale for the minimum output (0 or 4 mA) of the analog signal at terminal 42. Set the value to be the percentage of the full range of the variable selected in <i>parameter 6-50 Terminal 42 Output</i> .	

6-52 Terminal 42 Output Max Scale		
Range:	Function:	
100 %* [0 - 200 %]	Scale the maximum output of the selected analog signal at terminal 42. Set the value to the maximum value of the current signal output. Scale the output to give a current lower than 20 mA at full scale; or 20 mA at an output below 100% of the maximum signal value. If 20 mA is the desired output current at a value between 0 - 100% of the full-scale output, programme the percentage value in the parameter, i.e. 50% = 20 mA. If a current between 4 and 20 mA is desired at maximum output (100%), calculate the percentage value as follows:	

$20 \text{ mA} / \text{desired maximum current} \times 100\%$

i. e. $10 \text{ mA} : \frac{20}{10} \times 100 = 200\%$

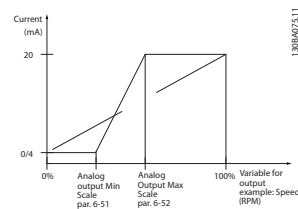

Figure 6.9 Output Max Scale

6-53 Terminal 42 Output Bus Control		
Range:	Function:	
0 %* [0 - 100 %]	Holds the level of Output 42 if controlled by bus.	

6.8 Par. Group 7 - Controllers

7-06 Speed PID Lowpass Filter Time		
Range:	Function:	
Size related*	[0.1 - 100 ms]	Set a time constant for the speed control low-pass filter. The low-pass filter improves steady-state performance and dampens oscillations on the feedback signal. This is an advantage if there is a great amount on noise in the system, see Figure 6.10. For example, if a time constant (τ) of 100 ms is programmed, the cut-off frequency for the low-pass filter will be $1/0.1 = 10 \text{ RAD/s}$, corresponding to $(10/2 \times \pi) = 1.6 \text{ Hz}$. The PID regulator only regulates a feedback signal that varies by a frequency of less than 1.6 Hz. If the feedback signal varies by a higher frequency than 1.6 Hz, the PID regulator does not react. Practical settings of parameter 7-06 Speed PID Lowpass Filter Time taken from the number of pulses per revolutions from encoder:
	Encoder PPR	Parameter 7-06 Speed PID Lowpass Filter Time
	512	10 ms
	1024	5 ms
	2048	2 ms
	4096	1 ms

NOTICE!

Severe filtering can be detrimental to dynamic performance.
This parameter is used with parameter 1-00 Configuration Mode [1] Speed closed loop and [2] Torque control.
The filter time in flux sensorless must be adjusted to 3-5 ms.

Feedback

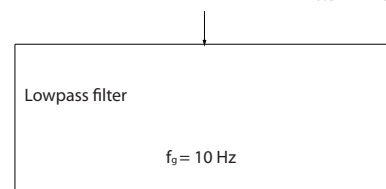
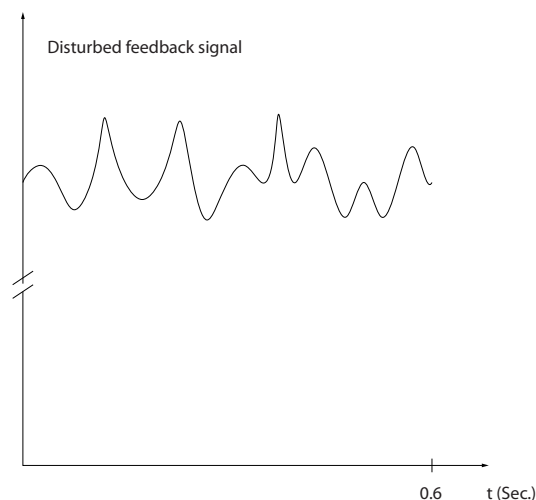

Feedback

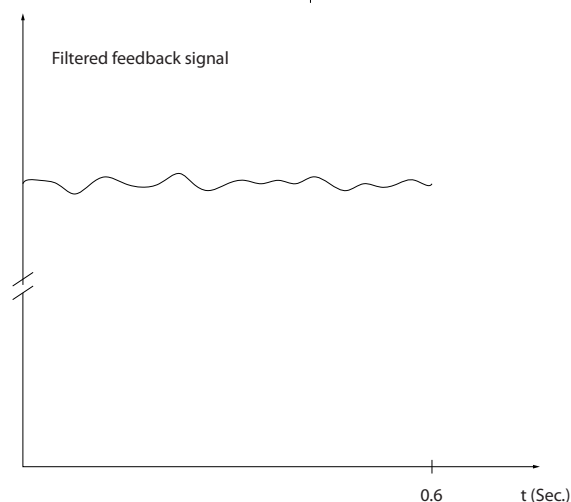

Figure 6.10 Feedback Signal

175ZA293.11

6.8.1 7-2* Process PID Feedback

Select the feedback sources for the Process PID Control, and how this feedback should be handled.

7-20 Process CL Feedback 1 Resource		
Option:	Function:	
		For process loop with current input, 54 switch has to be positioned on I (current).
[0]	No function	
[1]	Analog input 53	
[2] *	Analog input 54	
[3]	Frequency input 29 (FC 302 only)	
[4]	Frequency input 33	

7-32 Process PID Start Speed		
Range:	Function:	
3000 [RPM]	[Set point]	Enter the motor speed to be attained as a start signal for commencement of PID control. When the power is switched on, the frequency converter will commence ramping and then operate under speed open loop control. Thereafter, when the Process PID start speed is reached, the frequency converter will change over to Process PID control.

7-22 Process CL Feedback 2 Resource		
Option:	Function:	
		The effective feedback signal is made up of the sum of up to two different input signals. Select which frequency converter input should be treated as the source of the second of these signals. The first input signal is defined in <i>parameter 7-20 Process CL Feedback 1 Resource</i> .
[0]	No function	
[1]	Analog Input 53	
[2]	Analog Input 54	
[3]	Frequency input 29	
[4]	Frequency input 33	
[7]	Analog input X30/11	
[8]	Analog input X30/12	
[15]	Analog Input X48/2	

7-33 Process PID Proportional Gain		
Range:	Function:	
2.00N/A	[0.00 - 10.00 N/A]	Enter the PID proportional gain. The proportional gain multiplies the error between the set point and the feedback signal.

7-34 Process PID Integral Time		
Range:	Function:	
9.00 s*	[0.01 - 10000.00]	Enter the PID integral time. The integrator provides an increasing gain at a constant error between the set point and the feedback signal. The integral time is the time needed by the integrator to reach the same gain as the proportional gain.

7-30 Process PID Normal/Inverse Control		
Option:	Function:	
		Inverse action has to be selected for a process loop using a suction pressure sensor to control the system.
[0]	Normal	
[1] *	Inverse	

7-35 Process PID Differentiation Time		
Range:	Function:	
0.00 s*	[0.00 - 10.00 s]	Enter the PID differentiation time. The differentiator does not react to a constant error, but provides a gain only when the error changes. The shorter the PID differentiation time, the stronger the gain from the differentiator.

NOTICE!
 This PID parameters are comfortable to start any system, but depending on its design they have to be adjusted to follow the inertia and all responses of the real refrigeration machine.

7-31 Process PID Anti Windup		
Option:	Function:	
[0]	Off	Continue regulation of an error when the output frequency can no longer be adjusted.
[1] *	On	Continue regulation of an error even when the output frequency cannot be increased or decreased.

7-36 Process PID Differentiation Gain Limit		
Range:	Function:	
5 *	[1 - 50]	Enter a limit for the differentiator gain (DG). If there is no limit, the DG will increase when there are fast changes. Limit the DG to obtain a pure differentiator gain at slow changes and a constant differentiator gain where fast changes occur.

7-38 Process PID Feed Forward Factor		
Range:	Function:	
0 %* [0 - 200 %]	Enter the PID feed forward (FF) factor. The FF factor sends a constant fraction of the reference signal to bypass the PID control, so the PID control only affects the remaining fraction of the control signal. Any change to this parameter will thus affect the motor speed. When the FF factor is activated it provides less overshoot, and high dynamics when changing the set point. <i>parameter 7-38 Process PID Feed Forward Factor is active when parameter 1-00 Configuration Mode is set to [3] Process.</i>	

7-39 On Reference Bandwidth		
Range:	Function:	
5 %* [0 - 200 %]	Enter the On Reference bandwidth. When the PID Control Error (the difference between the reference and the feedback) is less than the set value of this parameter the On Reference status bit is high, i.e. =1.	

6.8.2 7-6* Feedback Conversion

Select how the signals from the feedback sources must be converted.

7-60 Feedback 1 Conversion		
Option:	Function:	
		Selects the conversion to apply to the feedback signal measured on the analog input selected as feedback 1 source in 7-20 <i>Process CL Feedback 1 Resource</i> .
[0] *	Linear	No conversion is applied. The feedback signal is assumed to be in the unit selected in 3-01 <i>Reference/Feedback Unit</i> and enters the process controller unchanged.
[1]	Square root	The square root of the feedback signal is calculated before passing it to the process controller.
[2]	Pressure to temperature	The feedback signal is a pressure with units as specified in 7-61 <i>Feedback 1 Source Unit</i> . It is converted to a temperature before passing it to the process controller. The pressure to temperature conversion is based on the refrigerant selected in 7-70 <i>Refrigerant</i> .

7-61 Feedback 1 Source Unit		
Option:	Function:	
		Select the pressure unit applicable to feedback source 1 defined in 7-20 <i>Process CL Feedback 1 Resource</i> .

7-61 Feedback 1 Source Unit		
Option:	Function:	
[70]	mbar	
[71]	bar	
[72]	Pa	
[73]	kPa	
[74]	m WG	
[170]	psi	
[171]	lb/in2	
[172]	in WG	
[173]	ft WG	

7-62 Feedback 2 Conversion		
Option:	Function:	
		Selects the conversion to apply to the feedback signal measured on the analog input selected as feedback 2 source in 7-22 <i>Process CL Feedback 2 Resource</i> .
[0] *	Linear	No conversion is applied. The feedback signal is assumed to be in the unit selected in 3-01 <i>Reference/Feedback Unit</i> and enters the process controller unchanged.
[1]	Square root	The square root of the feedback signal is calculated before passing it to the process controller.
[2]	Pressure to temperature	The feedback signal is a pressure with units as specified in 7-62 <i>Feedback 2 Source Unit</i> . It is converted to a temperature before passing it to the process controller. The pressure to temperature conversion is based on the refrigerant selected in 7-70 <i>Refrigerant</i> .

7-63 Feedback 2 Source Unit		
Option:	Function:	
		Select the pressure unit applicable to feedback source 1 defined in 7-22 <i>Process CL Feedback 2 Resource</i> .
[70]	mbar	
[71]	bar	
[72]	Pa	
[73]	kPa	
[74]	m WG	
[170]	psi	
[171]	lb/in2	
[172]	in WG	
[173]	ft WG	

6.8.3 7-7* Pressure to Temperature Conversion

The conversion of a feedback signal P in units of a pressure to a temperature T is accomplished via the formula:

$$T = A2 / (\log(P+1) - A1) - A3$$

where A1, A2 and A3 are refrigerant dependent constants.

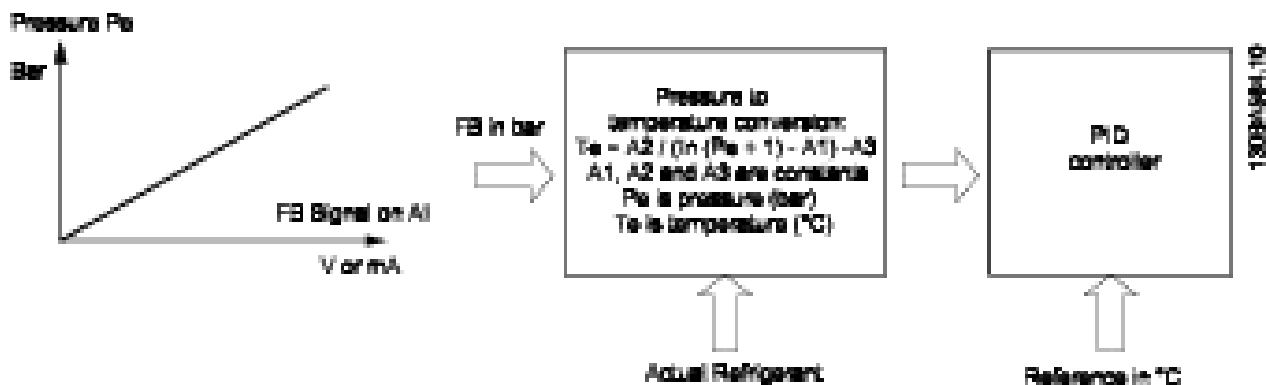

Figure 6.11 Converting Pressure to Temperature

The parameters in this group allow selection of a refrigerant, which implicitly determines the constants A1, A2 and A3. Alternatively, user defined constants can be programmed explicitly.

7-70 Refrigerant	
Option:	Function:
[0]	R22
[1]	R134a
[2] *	R404A
[3]	R407C
[4]	R410A
[5]	R502
[6]	R744
[7]	User defined

7-71 User Defined Refrigerant A1	
Range:	Function:
[8.0000 – 12.0000]	Selects the value used for the constant A1 in the pressure to temperature conversion formula (see parameter group 7-7* Pressure to Temperature Conversion).

7-72 User Defined Refrigerant A2	
Range:	Function:
[-3000.00 – -1500.00]	Selects the value used for the constant A2 in the pressure to temperature conversion formula (see parameter group 7-7* Pressure to Temperature Conversion).

7-73 User Defined Refrigerant A3	
Range:	Function:
[200.000 – 300.000]	Selects the value used for the constant A3 in the pressure to temperature conversion formula (see parameter group 7-7* Pressure to Temperature Conversion).

6.8.4 7-8* Thermostat/Pressostat Function

The Thermostat-Pressostat Function (TPF) can be used to stop and start the compressor when running in closed loop. The TPF monitors and compares the resulting feedback with the Cut-out value in *parameter 7-81 Cut-out Value*. When the resulting feedback gets below *parameter 7-81 Cut-out Value* a stop signal is generated and the compressor stops. When the resulting feedback gets above the Cut-in value in *parameter 7-82 Cut-in Value* the stop signal is removed and the compressor starts again.

The Set-point should be set to a value in between Cut-in and Cut-out.

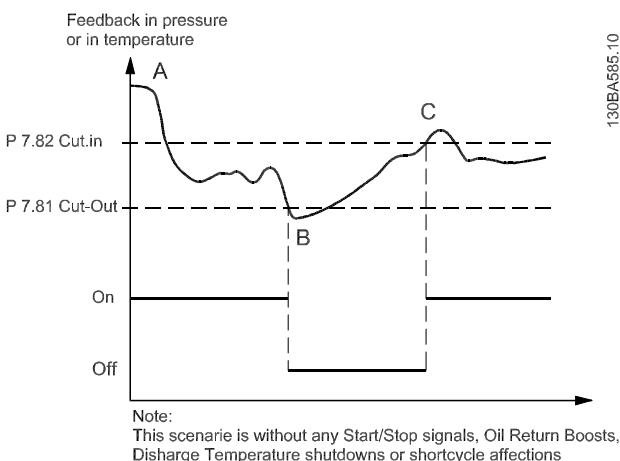

Figure 6.12 Thermostat/Pressostat Function

7-82 Cut-in Value		
Range:	Function:	
3 bar*	[Par.7-81 - 3000]	Select the Cut-in Level where the stop signal is de-activated and the compressor starts.

Point A: At start-up the temperature will be higher than wanted in the evaporator and therefore a higher pressure than the Cut-in level and the compressor must run. Another situation could be that the start situation is where the feedback is between Cut-out and Cut-in. In that case, no STOP is initiated.

Point B: After some time the cut-out level may be reached and the compressor must be shut off.

Point C: Cut-in is reached and the compressor is restarted.

NOTICE!

When using the TPF together with the Cascade Controller further consideration must be taken. The Cut-Out value should be below the Override Bandwidth setting (see parameter 25-21 Override Bandwidth). Cut-In should be set above the set-point and below the value for Staging Bandwidth (see parameter 25-20 Staging Bandwidth).

7-80 Thermostat/Pressostat Function

Option:	Function:	
[0] *	Off	Function is inactive
[1]	On	Function is active

7-81 Cut-out Value

Range:	Function:	
1 bar*	[-3000 - par. 7-82]	Select the Cut-out Level where the stop signal is activated and the compressor stops.

6.9 Parameters: 8-** Communications and Options

6.9.1 8-0* General Settings

8-01 Control Site		
Option:	Function:	
		The setting in this parameter overrides the settings in <i>parameter 8-50 Coasting Select</i> to <i>parameter 8-56 Preset Reference Select</i> .
[0]	Digital and ctrl.word	Control by using both digital input and control word.
[1]	Digital only	Control by using digital inputs only.
[2]	Controlword only	Control by using control word only.

8-02 Control Word Source		
Option:	Function:	
		<p>NOTICE! This parameter cannot be adjusted while the motor is running.</p> <p>Select the source of the control word: one of two serial interfaces or four installed options. During initial power-up, the frequency converter automatically sets this parameter to [3] <i>Option A</i> if it detects a valid fieldbus option installed in slot A. If the option is removed, the frequency converter detects a change in the configuration, sets <i>parameter 8-02 Control Word Source</i> back to default setting RS-485, and the frequency converter trips. If an option is installed after initial power-up, the setting of <i>parameter 8-02 Control Word Source</i> does not change, but the frequency converter trips and displays: <i>Alarm 67 Option Changed</i>. When retrofitting a bus option into a frequency converter that did not have a bus option installed to begin with, take an ACTIVE decision to move the control to Bus based. This is done for safety reasons to avoid an accidental change.</p>
[0]	None	
[1]	FC RS-485	
[2]	FC USB	
[3]	Option A	
[4]	Option B	
[5]	Option C0	
[6]	Option C1	
[30]	External Can	

8-03 Control Word Timeout Time		
Range:	Function:	
[1.0 s]	0.1-18000.0 s	Enter the maximum time expected to pass between the reception of two consecutive telegrams. If this time is exceeded, it indicates that the serial communication has stopped. The function selected in <i>parameter 8-04 Control Word Timeout Function</i> is then carried out. A valid control word triggers the time-out counter.
20 s*	[0.1 - 18000.0 s]	Enter the maximum time expected to pass between the reception of two consecutive telegrams. If this time is exceeded, it indicates that the serial communication has stopped. The function selected in <i>parameter 8-04 Control Word Timeout Function</i> is then carried out. A valid control word triggers the time-out counter.

8-04 Control Word Timeout Function		
Select the time-out function. The time-out function activates when the control word fails to be updated within the time period specified in <i>parameter 8-03 Control Word Timeout Time</i> .		
Option:	Function:	
[0]	Off	Resumes control via serial bus (fieldbus or standard) using the most recent control word.
[1]	Freeze output	Freezes output frequency until communication resumes.
[2]	Stop	Stops with auto restart when communication resumes.
[3]	Jogging	Runs the motor at JOG frequency until communication resumes.
[4]	Max. speed	Runs the motor at maximum frequency until communication resumes.
[5]	Stop and trip	Stops the motor, then resets the frequency converter to restart: via the fieldbus, via [Reset], or via a digital input.
[7]	Select setup 1	Changes the set-up upon reestablishment of communication following a control word time-out. If communication resumes after a time-out, <i>parameter 8-05 End-of-Timeout Function</i> defines whether to resume the set-up used before the time-out, or to retain the set-up endorsed by the time-out function.
[8]	Select setup 2	See [7] <i>Select setup 1</i>
[9]	Select setup 3	See [7] <i>Select setup 1</i>
[10]	Select setup 4	See [7] <i>Select setup 1</i>
[26]	Trip	

NOTICE!

To change the set-up after a time-out, the following configuration is required:

Set *parameter 0-10 Active Set-up* to [9] *Multi set-up* and select the relevant link in *parameter 0-12 This Set-up Linked to*.

8-05 End-of-Timeout Function		
Option:	Function:	
		Select the action after receiving a valid control word following a time-out. This parameter is active only when <i>parameter 8-04 Control Timeout Function</i> is set to [7] <i>Set-up 1</i> , [8] <i>Set-up 2</i> , [9] <i>Set-up 3</i> or [10] <i>Set-up 4</i> .
[0]	Hold set-up	Retains the set-up selected in <i>parameter 8-04 Control Timeout Function</i> and displays a warning, until <i>parameter 8-06 Reset Control Timeout</i> toggles. Then the frequency converter resumes its original set-up.
[1]	Resume set-up	Resumes the set-up active before the time-out.

8-06 Reset Control Word Timeout		
This parameter is active only when [0] <i>Hold set-up</i> has been selected in <i>parameter 8-05 End-of-Timeout Function</i> .		
Option:	Function:	
[0]	Do not reset	Retains the set-up specified in <i>parameter 8-04 Control Word Timeout Function</i> , following a control word time-out.
[1]	Do reset	Returns the frequency converter to the original set-up following a control word time-out. The frequency converter performs the reset and then immediately reverts to the [0] <i>Do not reset</i> setting

6.9.2 8-1* Ctrl. Word Settings

8-10 Control Word Profile

Select the interpretation of the control and status words corresponding to the installed fieldbus. Only the selections valid for the fieldbus installed in slot A will be visible in the LCP display.

For guidelines in selection of [0] *FC profile* and [1] *PROFIdrive profile*, refer to the *Serial communication via RS-485 Interface* section in the Design Guide.

For additional guidelines in the selection of [1] *PROFIdrive profile*, refer to the Operating Instructions for the installed fieldbus.

Option:	Function:	
[0] *	FC profile	
[1]	PROFIdrive profile	

8-13 Configurable Status Word STW

Option:	Function:	
[0]	No function	The input is always low.
[1] *	Profile Default	Depended on the profile set in <i>parameter 8-10 Control Profile</i> .
[2]	Alarm 68 Only	The input goes high whenever Alarm 68 is active and goes low whenever no alarm 68 is active.
[3]	Trip excl Alarm 68	
[16]	T37 DI status	The input goes high whenever T37 has 0 V and goes low whenever T37 has 24 V.

6.9.3 8-3* FC Port Settings

8-30 Protocol

Option:	Function:	
		Select the protocol to be used. Changing protocol will not be effective until after powering off the frequency converter.
[0] *	FC	
[1]	FC MC	
[2]	Modbus RTU	

8-31 Address

Range:	Function:	
Size related*	[1 - 255]	Enter the address for the FC (standard) port. Valid range: 1-126.

8-32 FC Port Baud Rate

Option:	Function:	
[0]	2400 Baud	Baud rate selection for the FC (standard) port.
[1]	4800 Baud	
[2]	9600 Baud	
[3]	19200 Baud	
[4]	38400 Baud	
[5]	57600 Baud	
[6]	76800 Baud	
[7]	115200 Baud	

8-33 Parity / Stop Bits

Option:	Function:	
[0]	Even Parity, 1 Stop Bit	
[1]	Odd Parity, 1 Stop Bit	
[2]	No Parity, 1 Stop Bit	
[3]	No Parity, 2 Stop Bits	

8-35 Minimum Response Delay		
Range:	Function:	
10 ms* [1 - 10000 ms]	Specify the minimum delay time between receiving a request and transmitting a response. This is used for overcoming modem turnaround delays.	

8-36 Max Response Delay		
Range:	Function:	
Size related* [11 - 10001 ms]	Specify the maximum permissible delay time between transmitting a request and receiving a response. If a response from the frequency converter is exceeding the time setting then it will be discarded.	

8-37 Max Inter-Char Delay		
Range:	Function:	
Size related* [0.00 - 35.00 ms]	Specify the maximum permissible time interval between receipt of two bytes. This parameter activates time-out if transmission is interrupted. This parameter is active only when parameter 8-30 Protocol is set to [1] FC MC protocol.	

6.9.4 8-5* Digital/Bus

Parameters for configuring the control word Digital/Bus merging.

NOTICE!

These parameters are active only when parameter 8-01 Control Site is set to [0] Digital and control word.

8-50 Coasting Select		
Option:	Function:	
		Select control of the coasting function via the terminals (digital input) and/or via the bus.
[0] Digital input		Activates Start command via a digital input.
[1] Bus		Activates Start command via the serial communication port or fieldbus option.
[2] Logic AND		Activates Start command via the fieldbus/serial communication port, AND additionally via one of the digital inputs.
[3] Logic OR		Activates Start command via the fieldbus/serial communication port OR via one of the digital inputs.

8-51 Quick Stop Select		
Select control of the Quick Stop function via the terminals (digital input) and/or via the bus.		
Option:	Function:	
[0]	Digital input	
[1]	Bus	
[2]	Logic AND	
[3]	Logic OR	

8-52 DC Brake Select		
Option:	Function:	
		Select control of the DC brake via the terminals (digital input) and/or via the fieldbus.
		NOTICE! Only selection [0] Digital input is available when parameter 1-10 Motor Construction is set to [1] PM non-salient SPM.
[0] Digital input		Activates Start command via a digital input.

8-53 Start Select		
Option:	Function:	
		Select control of the frequency converter start function via the terminals (digital input) and/or via the fieldbus.
[0] Digital input		Activates Start command via a digital input.
[1] Bus		Activates Start command via the serial communication port or fieldbus option.
[2] Logic AND		Activates Start command via the fieldbus/serial communication port, AND additionally via one of the digital inputs.
[3] Logic OR		Activates Start command via the fieldbus/serial communication port OR via one of the digital inputs.

8-54 Reverse Select		
Option:	Function:	
[0] Digital input		Select control of the frequency converter reverse function via the terminals (digital input) and/or via the fieldbus.
[1] Bus		Activates the Reverse command via the serial communication port or fieldbus option.
[2] Logic AND		Activates the Reverse command via the fieldbus/serial communication port, AND additionally via one of the digital inputs.
[3] Logic OR		Activates the Reverse command via the fieldbus/serial communication port OR via one of the digital inputs.

8-55 Set-up Select		
Option:	Function:	
		Select control of the frequency converter set-up selection via the terminals (digital input) and/or via the fieldbus.
[0]	Digital input	Activates the set-up selection via a digital input.
[1]	Bus	Activates the set-up selection via the serial communication port or fieldbus option.
[2]	Logic AND	Activates the set-up selection via the fieldbus/serial communication port, AND additionally via one of the digital inputs.
[3]	Logic OR	Activate the set-up selection via the fieldbus/serial communication port OR via one of the digital inputs.

8-56 Preset Reference Select		
Option:	Function:	
		Select control of the frequency converter Preset Reference selection via the terminals (digital input) and/or via the fieldbus.
[0]	Digital input	Activates Preset Reference selection via a digital input.
[1]	Bus	Activates Preset Reference selection via the serial communication port or fieldbus option.
[2]	Logic AND	Activates Preset Reference selection via the fieldbus/serial communication port, AND additionally via one of the digital inputs.
[3]	Logic OR	Activates the Preset Reference selection via the fieldbus/serial communication port OR via one of the digital inputs.

6.9.5 8-8* FC Port Diagnostics

These parameters are used for monitoring the Bus communication via the FC Port.

8-80 Bus Message Count		
Range:	Function:	
0 *	[0 - 0]	This parameter shows the number of valid telegrams detected on the bus.

8-81 Bus Error Count		
Range:	Function:	
0 *	[0 - 0]	This parameter shows the number of telegrams with faults (e.g. CRC fault), detected on the bus.

8-82 Slave Messages Rcvd		
Range:	Function:	
0 *	[0 - 0]	This parameter shows the number of valid telegrams addressed to the slave, sent by the frequency converter.

8-83 Slave Error Count		
Range:	Function:	
0 *	[0 - 0]	This parameter shows the number of error telegrams, which could not be executed by the frequency converter.

6.9.6 8-9* Bus Jog

8-90 Bus Jog 1 Speed		
Range:	Function:	
100 RPM*	[0 - par. 4-13 RPM]	Enter the jog speed. Activate this fixed jog speed via the serial port or fieldbus option.

8-91 Bus Jog 2 Speed		
Range:	Function:	
200 RPM*	[0 - par. 4-13 RPM]	Enter the jog speed. Activate this fixed jog speed via the serial port or fieldbus option.

6.10 Par. Group 13 - Smart Logic Control

6.10.1 Prog. Features

Smart Logic Control (SLC) is essentially a sequence of user defined actions (see *parameter 13-52 SL Controller Action [x]*) executed by the SLC when the associated user defined event (see *parameter 13-51 SL Controller Event [x]*) is evaluated as TRUE by the SLC.

The condition for an event can be a particular status or that the output from a Logic Rule or a Comparator Operand becomes TRUE. That will lead to an associated Action as illustrated:

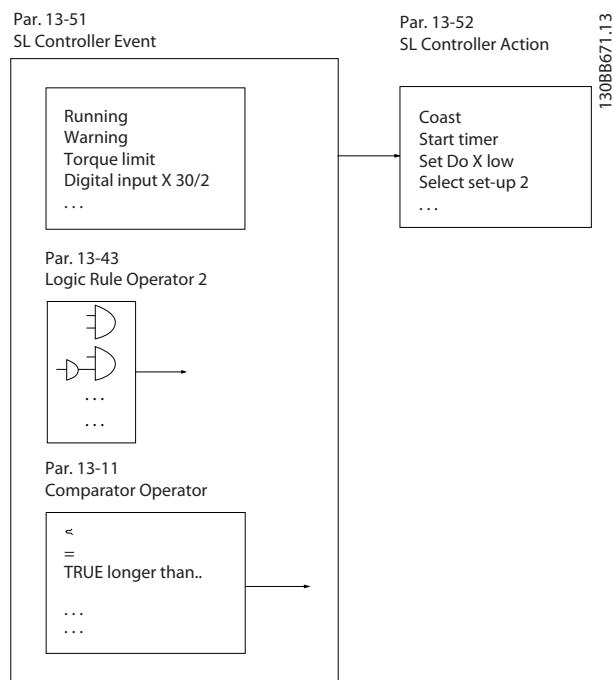

Figure 6.13 Smart Logic Control (SLC)

Events and actions are each numbered and linked together in pairs (states). This means that when event [0] is fulfilled (attains the value TRUE), action [0] is executed. After this, the conditions of event [1] will be evaluated and if evaluated TRUE, action [1] will be executed and so on. Only one event will be evaluated at any time. If an event is evaluated as FALSE, nothing happens (in the SLC) during the current scan interval and no other events will be evaluated. This means that when the SLC starts, it evaluates event [0] (and only event [0]) each scan interval. Only when event [0] is evaluated TRUE, will the SLC execute action [0] and start evaluating event [1]. It is possible to programme from 1 to 20 events and actions.

When the last event/action has been executed, the sequence starts over again from event [0]/action [0]. The illustration shows an example with three event/actions:

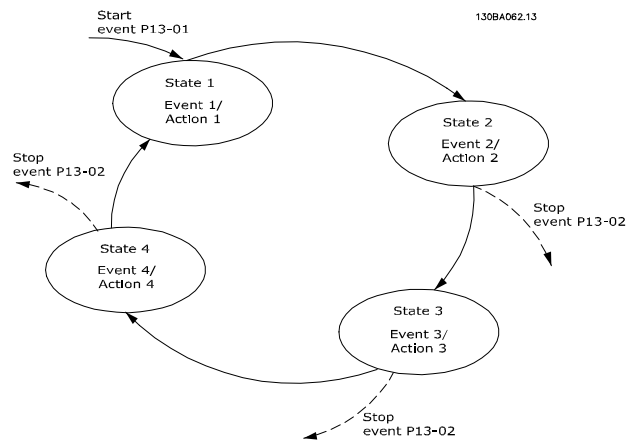

Figure 6.14 Events and Actions

Starting and stopping the SLC:

Starting and stopping the SLC can be done by selecting .On [1]. or .Off [0]. in *parameter 13-00 SL Controller Mode*. The SLC always starts in state 0 (where it evaluates event [0]). The SLC starts when the Start Event (defined in *parameter 13-01 Start Event*) is evaluated as TRUE (provided that On [1] is selected in *parameter 13-00 SL Controller Mode*). The SLC stops when the Stop Event (*parameter 13-02 Stop Event*) is TRUE. *parameter 13-03 Reset SLC* resets all SLC parameters and start programming from scratch.

NOTICE!

SLC is only active in AUTO mode, not Hand On mode

6.10.2 13-0* SLC Settings

Use the SLC settings to activate, deactivate and reset the Smart Logic Control sequence. The logic functions and comparators are always running in the background, which opens for separate control of digital inputs and outputs.

13-00 SLC Controller Mode

Option: Function:

[0] *	Off	Disables the Smart Logic Control.
[1]	On	Enables the Smart Logic Control to start when a start command is present, e.g. via a digital input.

13-01 Start Event		
Select the boolean (TRUE or FALSE) input to activate Smart Logic Control.		
Option:	Function:	
[0]	FALSE	Select the boolean (TRUE or FALSE) input to activate Smart Logic Control. Enters the fixed value - FALSE
[1]	TRUE	Enters the fixed value - TRUE.
[2]	Running	The motor is running.
[3]	In range	The motor is running within the programmed current and speed ranges set in <i>parameter 4-50 Warning Current Low</i> to <i>parameter 4-53 Warning Speed High</i> .
[4]	On reference	The motor is running on reference.
[5]	Torque limit	The torque limit, set in <i>parameter 4-16 Torque Limit Motor Mode</i> or <i>parameter 4-17 Torque Limit Generator Mode</i> , has been exceeded.
[6]	Current Limit	The motor current limit, set in <i>parameter 4-18 Current Limit</i> , has been exceeded.
[7]	Out of current range	The motor current is outside the range set in <i>parameter 4-18 Current Limit</i> .
[8]	Below I low	The motor current is lower than set in <i>parameter 4-50 Warning Current Low</i> .
[9]	Above I high	The motor current is higher than set in <i>parameter 4-51 Warning Current High</i> .
[10]	Out of speed range	The speed is outside the range set in <i>parameter 4-52 Warning Speed Low</i> and <i>parameter 4-53 Warning Speed High</i> .
[11]	Below speed low	The output speed is lower than the setting in <i>parameter 4-52 Warning Speed Low</i> .
[12]	Above speed high	The output speed is higher than the setting in <i>parameter 4-53 Warning Speed High</i> .
[13]	Out of feedb. range	The feedback is outside the range set in <i>parameter 4-56 Warning Feedback Low</i> and <i>parameter 4-57 Warning Feedback High</i> .
[14]	Below feedb. low	The feedback is below the limit set in <i>parameter 4-56 Warning Feedback Low</i> .
[15]	Above feedb. high	The feedback is above the limit set in <i>parameter 4-57 Warning Feedback High</i> .
[16]	Thermal warning	The thermal warning turns on when the temperature exceeds the limit in the

13-01 Start Event		
Select the boolean (TRUE or FALSE) input to activate Smart Logic Control.		
Option:	Function:	
		motor, the frequency converter, the brake resistor or the thermistor.
[17]	Mains out of range	The mains voltage is outside the specified voltage range.
[18]	Reverse	The output is high when the frequency converter is running counter clockwise (the logical product of the status bits "running" AND "reverse").
[19]	Warning	A warning is active.
[20]	Alarm (trip)	A (trip) alarm is active.
[21]	Alarm (trip lock)	A (Trip lock) alarm is active.
[22]	Comparator 0	Use the result of comparator 0.
[23]	Comparator 1	Use the result of comparator 1.
[24]	Comparator 2	Use the result of comparator 2.
[25]	Comparator 3	Use the result of comparator 3.
[26]	Logic rule 0	Use the result of logic rule 0.
[27]	Logic rule 1	Use the result of logic rule 1.
[28]	Logic rule 2	Use the result of logic rule 2.
[29]	Logic rule 3	Use the result of logic rule 3.
[33]	Digital input DI18	Use the result of digital input 18.
[34]	Digital input DI19	Use the result of digital input 19.
[35]	Digital input DI27	Use the result of digital input 27.
[36]	Digital input DI29	Use the result of digital input 29.
[37]	Digital input DI32	Use the result of digital input 32.
[38]	Digital input DI33	Use the result of digital input 33.
[39]	Start command	A start command is issued.
[40]	Drive stopped	A stop command (Jog, Stop, Qstop, Coast) is issued – and not from the SLC itself.
[41]	Reset Trip	A reset is issued
[42]	Auto-reset Trip	An Auto reset is performed.
[43]	OK key	[OK] is pressed.
[44]	Reset key	[Reset] is pressed.
[45]	Left key	[←] is pressed.
[46]	Right key	[→] is pressed.

13-01 Start Event		
Select the boolean (TRUE or FALSE) input to activate Smart Logic Control.		
Option:	Function:	
[47]	Up key	[▲] is pressed.
[48]	Down key	[▼] is pressed.
[50]	Comparator 4	Use the result of comparator 4.
[51]	Comparator 5	Use the result of comparator 5.
[60]	Logic rule 4	Use the result of logic rule 4.
[61]	Logic rule 5	Use the result of logic rule 5.
[94]	RS Flipflop 0	See parameter group 13-1* Comparators
[95]	RS Flipflop 1	See parameter group 13-1* Comparators
[96]	RS Flipflop 2	See parameter group 13-1* Comparators
[97]	RS Flipflop 3	See parameter group 13-1* Comparators
[98]	RS Flipflop 4	See parameter group 13-1* Comparators
[99]	RS Flipflop 5	See parameter group 13-1* Comparators
[100]	RS Flipflop 6	See parameter group 13-1* Comparators
[101]	RS Flipflop 7	See parameter group 13-1* Comparators

13-02 Stop Event		
Select the boolean (TRUE or FALSE) input to deactivate Smart Logic Control.		
Option:	Function:	
[0]	FALSE	For descriptions [0]-[61], see parameter 13-01 Start Event Start Event
[1]	TRUE	
[2]	Running	
[3]	In range	
[4]	On reference	
[5]	Torque limit	
[6]	Current Limit	
[7]	Out of current range	
[8]	Below I low	
[9]	Above I high	
[10]	Out of speed range	
[11]	Below speed low	
[12]	Above speed high	
[13]	Out of feedb. range	
[14]	Below feedb. low	
[15]	Above feedb. high	
[16]	Thermal warning	
[17]	Mains out of range	
[18]	Reverse	
[19]	Warning	
[20]	Alarm (trip)	
[21]	Alarm (trip lock)	

13-02 Stop Event		
Select the boolean (TRUE or FALSE) input to deactivate Smart Logic Control.		
Option:	Function:	
[22]	Comparator 0	
[23]	Comparator 1	
[24]	Comparator 2	
[25]	Comparator 3	
[26]	Logic rule 0	
[27]	Logic rule 1	
[28]	Logic rule 2	
[29]	Logic rule 3	
[30]	SL Timeout 0	
[31]	SL Timeout 1	
[32]	SL Timeout 2	
[33]	Digital input DI18	
[34]	Digital input DI19	
[35]	Digital input DI27	
[36]	Digital input DI29	
[37]	Digital input DI32	
[38]	Digital input DI33	
[39]	Start command	
[40]	Drive stopped	
[41]	Reset Trip	
[42]	Auto-reset Trip	
[43]	OK key	
[44]	Reset key	
[45]	Left key	
[46]	Right key	
[47]	Up key	
[48]	Down key	
[50]	Comparator 4	
[51]	Comparator 5	
[60]	Logic rule 4	
[61]	Logic rule 5	
[70]	SL Timeout 3	Smart Logic Controller timer 3 is timed out.
[71]	SL Timeout 4	Smart Logic Controller timer 4 is timed out.
[72]	SL Timeout 5	Smart Logic Controller timer 5 is timed out.
[73]	SL Timeout 6	Smart Logic Controller timer 6 is timed out.
[74]	SL Timeout 7	Smart Logic Controller timer 7 is timed out.
[75]	Start command given	
[76]	Digital input x30/2	
[77]	Digital input x30/3	
[78]	Digital input x30/4	
[79]	Digital input x46/1	

13-02 Stop Event		
Select the boolean (TRUE or FALSE) input to deactivate Smart Logic Control.		
Option:	Function:	
[80]	Digital input x46/3	
[81]	Digital input x46/5	
[82]	Digital input x46/7	
[83]	Digital input x46/9	
[84]	Digital input x46/11	
[85]	Digital input x46/13	
[90]	ATEX ETR cur. warning	Selectable if <i>parameter 1-90 Motor Thermal Protection</i> is set to [20] ATEX ETR or [21] Advanced ETR. If the alarm 164 ATEX ETR cur.lim.alarm is active, the output will be 1.
[91]	ATEX ETR cur. alarm	Selectable if <i>parameter 1-90 Motor Thermal Protection</i> is set to [20] ATEX ETR or [21] Advanced ETR. If the alarm 166 ATEX ETR freq.lim.alarm is active, the output will be 1.
[92]	ATEX ETR freq. warning	Selectable if <i>parameter 1-90 Motor Thermal Protection</i> is set to [20] ATEX ETR or [21] Advanced ETR. If the alarm 163 ATEX ETR cur.lim.warning is active, the output will be 1.
[93]	ATEX ETR freq. alarm	Selectable if <i>parameter 1-90 Motor Thermal Protection</i> is set to [20] ATEX ETR or [21] Advanced ETR. If the warning 165 ATEX ETR freq.lim.warning is active, the output will be 1.
[94]	RS Flipflop 0	See parameter group 13-1* Comparators
[95]	RS Flipflop 1	See parameter group 13-1* Comparators
[96]	RS Flipflop 2	See parameter group 13-1* Comparators
[97]	RS Flipflop 3	See parameter group 13-1* Comparators
[98]	RS Flipflop 4	See parameter group 13-1* Comparators
[99]	RS Flipflop 5	See parameter group 13-1* Comparators
[100]	RS Flipflop 6	See parameter group 13-1* Comparators

13-02 Stop Event		
Select the boolean (TRUE or FALSE) input to deactivate Smart Logic Control.		
Option:	Function:	
[101]	RS Flipflop 7	See parameter group 13-1* Comparators

13-03 Reset SLC		
Option:	Function:	
[0]	Do not reset SLC	Retains programmed settings in all parameter group 13-** Smart Logic Control.
[1]	Reset SLC	Resets all parameters in parameter group 13-** Smart Logic Control to default settings.

6.10.3 13-1* Comparators

Comparators are used for comparing continuous variables (i.e. output frequency, output current, analog input etc.) to fixed preset values.

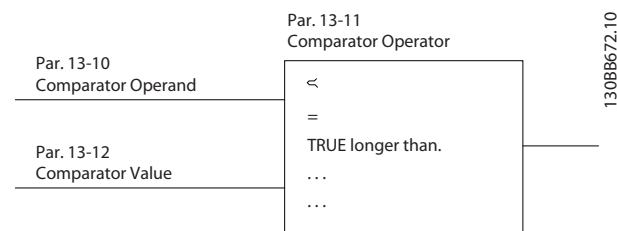

Figure 6.15 Comparators

In addition, there are digital values that will be compared to fixed time values. See explanation in *parameter 13-10 Comparator Operand*. Comparators are evaluated once in each scan interval. Use the result (TRUE or FALSE) directly. All parameters in this parameter group are array parameters with index 0 to 5. Select index 0 to programme Comparator 0, select index 1 to programme Comparator 1, and so on.

13-10 Comparator Operand		
Array [6]		
Option:	Function:	
		Choices [1] to [31] are variables which will be compared based on their values. Choices [50] to [186] are digital values (TRUE/FALSE) where the comparison is based on the amount of time during which they are set to TRUE or FALSE, respectively. See <i>parameter 13-11 Comparator Operator</i> .

13-10 Comparator Operand		
Array [6]		
Option:	Function:	
		Select the variable to be monitored by the comparator.
[0]	DISABLED	The comparator is disabled.
[1]	Reference	The resulting remote reference (not local) as a percentage.
[2]	Feedback	In the unit [RPM] or [Hz]
[3]	Motor speed	[RPM] or [Hz]
[4]	Motor Current	[A]
[5]	Motor torque	[Nm]
[6]	Motor power	[kW] or [hp]
[7]	Motor voltage	[V]
[8]	DC-link voltage	[V]
[9]	Motor Thermal	Expressed as a percentage.
[10]	VLT temp.	Expressed as a percentage.
[11]	Heat sink temp.	Expressed as a percentage.
[12]	Analog input AI53	Expressed as a percentage.
[13]	Analog input AI54	Expressed as a percentage.
[14]	Analog input AIFB10	[V]. AIFB10 is internal 10 V supply.
[15]	Analog input AIS24V	[V] Analog input AICCT [17] [°]. AIS24V is switch mode power supply: SMPS 24V.
[17]	Analog input AICCT	[°]. AICCT is control card temperature.
[18]	Pulse input FI29	Expressed as a percentage.
[19]	Pulse input FI33	Expressed as a percentage.
[20]	Alarm number	The error number.
[21]	Warning number	
[22]	Analog input x30 11	
[23]	Analog input x30 12	
[30]	Counter A	Number of counts
[31]	Counter B	Number of counts
[50]	FALSE	Enters the fixed value of false in the comparator.
[51]	TRUE	Enters the fixed value of true in the comparator.
[52]	Control ready	The control board receives supply voltage

13-10 Comparator Operand		
Array [6]		
Option:	Function:	
[53]	Drive ready	The frequency converter is ready for operation and applies a supply signal on the control board.
[54]	Running	The motor is running.
[55]	Reversing	The output is high when the frequency converter is running counter clockwise (the logical product of the status bits "running" AND "reverse").
[56]	In range	The motor is running within the programmed current and speed ranges set in <i>parameter 4-50 Warning Current Low</i> to <i>parameter 4-53 Warning Speed High</i> .
[60]	On reference	The motor is running on reference.
[61]	Below Reference Low	The motor is running below the value given in <i>parameter 4-54 Warning Reference Low</i> .
[62]	Above ref, high	The motor is running above the value given in <i>parameter 4-55 Warning Reference High</i>
[65]	Torque limit	The torque limit, set in <i>parameter 4-16 Torque Limit Motor Mode</i> or <i>parameter 4-17 Torque Limit Generator Mode</i> , has been exceeded.
[66]	Current Limit	The motor current limit, set in <i>parameter 4-18 Current Limit</i> , has been exceeded.
[67]	Out of current range	The motor current is outside the range set in <i>parameter 4-18 Current Limit</i> .
[68]	Below I low	The motor current is lower than set in <i>parameter 4-50 Warning Current Low</i> .
[69]	Above I high	The motor current is higher than set in <i>parameter 4-51 Warning Current High</i> .
[70]	Out of speed range	The speed is outside the range set in <i>parameter 4-52 Warning Speed Low</i> and <i>parameter 4-53 Warning Speed High</i> .
[71]	Below speed low	The output speed is lower than the setting in <i>parameter 4-52 Warning Speed Low</i> .
[72]	Above speed high	The output speed is higher than the setting in <i>parameter 4-53 Warning Speed High</i> .
[75]	Out of feedb. range	The feedback is outside the range set in <i>parameter 4-56 Warning Feedback Low</i> and <i>parameter 4-57 Warning Feedback High</i> .

13-10 Comparator Operand		
Array [6]		
Option:	Function:	
[76]	Below feedback low	The feedback is below the limit set in <i>parameter 4-56 Warning Feedback Low</i> .
[77]	Above feedback high	The feedback is above the limit set in <i>parameter 4-57 Warning Feedback High</i> .
[80]	Thermal warning	The thermal warning turns on when the temperature exceeds the limit in the motor, the frequency converter, the brake resistor or thermistor.
[82]	Line pwr out of range	The mains voltage is outside the specified voltage range.
[85]	Warning	A warning is active.
[86]	ALARM (Trip)	A (trip) alarm is active.
[87]	ALARM (Trip Lock)	A (Trip lock) alarm is active.
[90]	Bus OK	Active communication (no time-out) via the serial communication port.
[91]	Torque limit & stop	If the frequency converter has received a stop signal and is at the torque limit, the signal is logic "0".
[92]	Brake fault (IGBT)	The brake IGBT is short circuited.
[93]	Mech. brake control	The mechanical brake is active.
[94]	Safe stop active	
[100]	Comparator 0	The result of comparator 0.
[101]	Comparator 1	The result of comparator 1.
[102]	Comparator 2	The result of comparator 2.
[103]	Comparator 3	The result of comparator 3.
[104]	Comparator 4	The result of comparator 4.
[105]	Comparator 5	The result of comparator 5.
[110]	Logic rule 0	The result of Logic rule 0.
[111]	Logic rule 1	The result of Logic rule 1.
[112]	Logic rule 2	The result of Logic rule 2.
[113]	Logic rule 3	The result of Logic rule 3.
[114]	Logic rule 4	The result of Logic rule 4.
[115]	Logic rule 5	The result of Logic rule 5.
[120]	SL Timeout 0	The result of SLC timer 0.
[121]	SL Timeout 1	The result of SLC timer 1.
[122]	SL Timeout 2	The result of SLC timer 2.
[123]	SL Timeout 3	The result of SLC timer 3.

13-10 Comparator Operand		
Array [6]		
Option:	Function:	
[124]	SL Timeout 4	The result of SLC timer 4.
[125]	SL Timeout 5	The result of SLC timer 5.
[126]	SL Timeout 6	The result of SLC timer 6.
[127]	SL Timeout 7	The result of SLC timer 7.
[130]	Digital input DI18	Digital input 18. High = True.
[131]	Digital input DI19	Digital input 19. High = True.
[132]	Digital input DI27	Digital input 27. High = True.
[133]	Digital input DI29	Digital input 29. High = True.
[134]	Digital input DI32	Digital input 32. High = True.
[135]	Digital input DI33	Digital input 33. High = True.
[150]	SL digital output A	Use the result of the SLC output A.
[151]	SL digital output B	Use the result of the SLC output B.
[152]	SL digital output C	Use the result of the SLC output C.
[153]	SL digital output D	Use the result of the SLC output D.
[154]	SL digital output E	Use the result of the SLC output E.
[155]	SL digital output F	Use the result of the SLC output F.
[160]	Relay 1	Relay 1 is active
[161]	Relay 2	Relay 2 is active
[180]	Local reference active	High when <i>parameter 3-13 Reference Site = [2] Local</i> or when <i>parameter 3-13 Reference Site is [0] Linked to hand Auto</i> , at the same time as the LCP is in Hand On mode.
[181]	Remote ref. active	High when <i>parameter 3-13 Reference Site = [1] Remote</i> or <i>[0] Linked to hand/auto</i> , while the LCP is in Auto On mode.
[182]	Start command	High when there is an active start command, and no stop command.
[183]	Drive stopped	A stop command (Jog, Stop, Qstop, Coast) is issued – and not from the SLC itself.
[185]	Drive in hand mode	High when the frequency converter is in hand mode.

13-10 Comparator Operand		
Array [6]		
Option:	Function:	
[186]	Drive in auto mode	High when the frequency converter is in auto mode.
[187]	Start command given	
[190]	Digital input x30 2	
[191]	Digital input x30 3	
[192]	Digital input x30 4	
[193]	Digital input x46 1	
[194]	Digital input x46 2	
[195]	Digital input x46 3	
[196]	Digital input x46 4	
[197]	Digital input x46 5	
[198]	Digital input x46 6	
[199]	Digital input x46 7	

13-11 Comparator Operator		
Array [6]		
Option:	Function:	
		Select the operator to be used in the comparison. This is an array parameter containing comparator operators 0 to 5.
[0]	<	The result of the evaluation is TRUE, when the variable selected in <i>parameter 13-10 Comparator Operand</i> is smaller than the fixed value in <i>parameter 13-12 Comparator Value</i> . The result is FALSE, if the variable selected in <i>parameter 13-10 Comparator Operand</i> is greater than the fixed value in <i>parameter 13-12 Comparator Value</i> .
[1]	= (equal)	The result of the evaluation is TRUE, when the variable selected in <i>parameter 13-10 Comparator Operand</i> is approximately equal to the fixed value in <i>parameter 13-12 Comparator Value</i> .
[2]	>	Inverse logic of option < [0].
[5]	TRUE longer than...	

13-11 Comparator Operator		
Array [6]		
Option:	Function:	
[6]	FALSE longer than...	
[7]	TRUE shorter than...	
[8]	FALSE shorter than...	

13-12 Comparator Value		
Array [6]		
Range:	Function:	
Size related*	[-100000 - 100000]	Enter the 'trigger level' for the variable that is monitored by this comtor. This is an array parameter containing comtor values 0 to 5.

6.10.4 13-1* RS Flip Flops

The Reset/Set Flip Flops hold the signal until set/reset.

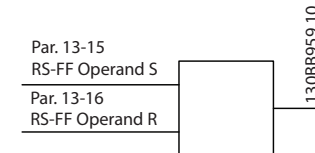

Figure 6.16 Reset/Set Flip Flops

Two parameters are used and the output can be used in the logic rules and as events.

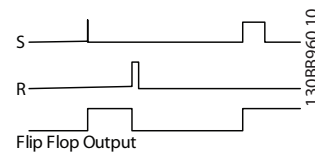

Figure 6.17 Flip Flop Outputs

The two operators can be selected from a long list. As a special case, the same digital input can be used as both Set and Reset, making it possible to use the same digital input as start/stop. The following settings can be used to set up the same digital input as start/stop (example given with DI32 but is not a requirement).

Parameter	Setting	Notes
Parameter 13-00 SL Controller Mode	On	
Parameter 13-01 Start Event	TRUE	
Parameter 13-02 Stop Event	FALSE	
Parameter 13-40 Logic Rule Boolean 1 [0]	[37] Digital Input DI32	
Parameter 13-42 Logic Rule Boolean 2 [0]	[2] Running	
Parameter 13-41 Logic Rule Operator 1 [0]	[3] AND NOT	
Parameter 13-40 Logic Rule Boolean 1 [1]	[37] Digital Input DI32	
Parameter 13-42 Logic Rule Boolean 2 [1]	[2] Running	
Parameter 13-41 Logic Rule Operator 1 [1]	[1] AND	
Parameter 13-15 RS-FF Operand S [0]	[26] Logicrule 0	Output from 13-41 [0]
Parameter 13-16 RS-FF Operand R [0]	[27] Logicrule 1	Output from 13-41 [1]
Parameter 13-51 SL Controller Event [0]	[94] RS Flipflop 0	Output from evaluating 13-15 and 13-16
Parameter 13-52 SL Controller Action [0]	[22] Run	
Parameter 13-51 SL Controller Event [1]	[27] Logicrule 1	
Parameter 13-52 SL Controller Action [1]	[24] Stop	

Table 6.9 Operators

13-15 RS-FF Operand S		
Option:	Function:	
[0]	FALSE	
[1]	TRUE	
[2]	Running	
[3]	In range	
[4]	On reference	
[5]	Torque limit	
[6]	Current Limit	
[7]	Out of current range	
[8]	Below I low	
[9]	Above I high	
[10]	Out of speed range	
[11]	Below speed low	
[12]	Above speed high	
[13]	Out of feedb. range	

13-15 RS-FF Operand S		
Option:	Function:	
[14]	Below feedb. low	
[15]	Above feedb. high	
[16]	Thermal warning	
[17]	Mains out of range	
[18]	Reverse	
[19]	Warning	
[20]	Alarm (trip)	
[21]	Alarm (trip lock)	
[22]	Comparator 0	
[23]	Comparator 1	
[24]	Comparator 2	
[25]	Comparator 3	
[26]	Logic rule 0	
[27]	Logic rule 1	
[28]	Logic rule 2	
[29]	Logic rule 3	
[30]	SL Timeout 0	
[31]	SL Timeout 1	
[32]	SL Timeout 2	
[33]	Digital input DI18	
[34]	Digital input DI19	
[35]	Digital input DI27	
[36]	Digital input DI29	
[37]	Digital input DI32	
[38]	Digital input DI33	
[39]	Start command	
[40]	Drive stopped	
[41]	Reset Trip	
[42]	Auto-reset Trip	
[43]	OK key	
[44]	Reset key	
[45]	Left key	
[46]	Right key	
[47]	Up key	
[48]	Down key	
[50]	Comparator 4	
[51]	Comparator 5	
[60]	Logic rule 4	
[61]	Logic rule 5	
[70]	SL Timeout 3	
[71]	SL Timeout 4	
[72]	SL Timeout 5	
[73]	SL Timeout 6	
[74]	SL Timeout 7	
[75]	Start command given	
[76]	Digital input x30/2	
[77]	Digital input x30/3	
[78]	Digital input x30/4	
[79]	Digital input x46/1	

13-15 RS-FF Operand S		
Option:	Function:	
[80]	Digital input x46/3	
[81]	Digital input x46/5	
[82]	Digital input x46/7	
[83]	Digital input x46/9	
[84]	Digital input x46/11	
[85]	Digital input x46/13	
[90]	ATEX ETR cur. warning	
[91]	ATEX ETR cur. alarm	
[92]	ATEX ETR freq. warning	
[93]	ATEX ETR freq. alarm	
[94]	RS Flipflop 0	
[95]	RS Flipflop 1	
[96]	RS Flipflop 2	
[97]	RS Flipflop 3	
[98]	RS Flipflop 4	
[99]	RS Flipflop 5	
[100]	RS Flipflop 6	
[101]	RS Flipflop 7	

13-16 RS-FF Operand R		
Option:	Function:	
[0]	FALSE	
[1]	TRUE	
[2]	Running	
[3]	In range	
[4]	On reference	
[5]	Torque limit	
[6]	Current Limit	
[7]	Out of current range	
[8]	Below I low	
[9]	Above I high	
[10]	Out of speed range	
[11]	Below speed low	
[12]	Above speed high	
[13]	Out of feedb. range	
[14]	Below feedb. low	
[15]	Above feedb. high	
[16]	Thermal warning	
[17]	Mains out of range	
[18]	Reverse	
[19]	Warning	
[20]	Alarm (trip)	
[21]	Alarm (trip lock)	
[22]	Comparator 0	
[23]	Comparator 1	
[24]	Comparator 2	
[25]	Comparator 3	
[26]	Logic rule 0	
[27]	Logic rule 1	
[28]	Logic rule 2	

13-16 RS-FF Operand R		
Option:	Function:	
[29]	Logic rule 3	
[30]	SL Timeout 0	
[31]	SL Timeout 1	
[32]	SL Timeout 2	
[33]	Digital input DI18	
[34]	Digital input DI19	
[35]	Digital input DI27	
[36]	Digital input DI29	
[37]	Digital input DI32	
[38]	Digital input DI33	
[39]	Start command	
[40]	Drive stopped	
[41]	Reset Trip	
[42]	Auto-reset Trip	
[43]	OK key	
[44]	Reset key	
[45]	Left key	
[46]	Right key	
[47]	Up key	
[48]	Down key	
[50]	Comparator 4	
[51]	Comparator 5	
[60]	Logic rule 4	
[61]	Logic rule 5	
[70]	SL Timeout 3	
[71]	SL Timeout 4	
[72]	SL Timeout 5	
[73]	SL Timeout 6	
[74]	SL Timeout 7	
[75]	Start command given	
[76]	Digital input x30/2	
[77]	Digital input x30/3	
[78]	Digital input x30/4	
[79]	Digital input x46/1	
[80]	Digital input x46/3	
[81]	Digital input x46/5	
[82]	Digital input x46/7	
[83]	Digital input x46/9	
[84]	Digital input x46/11	
[85]	Digital input x46/13	
[90]	ATEX ETR cur. warning	
[91]	ATEX ETR cur. alarm	
[92]	ATEX ETR freq. warning	
[93]	ATEX ETR freq. alarm	
[94]	RS Flipflop 0	
[95]	RS Flipflop 1	
[96]	RS Flipflop 2	
[97]	RS Flipflop 3	
[98]	RS Flipflop 4	
[99]	RS Flipflop 5	

13-16 RS-FF Operand R	
Option:	Function:
[100]	RS Flipflop 6
[101]	RS Flipflop 7

6.10.5 13-2* Timers

Use the result (TRUE or FALSE) from *timers* directly to define an *event* (see *parameter 13-51 SL Controller Event*), or as boolean input in a *logic rule* (see *parameter 13-40 Logic Rule Boolean 1*, *parameter 13-42 Logic Rule Boolean 2* or *parameter 13-44 Logic Rule Boolean 3*). A timer is only FALSE when started by an action (i.e. [29] *Start timer 1*) until the timer value entered in this parameter is elapsed. Then it becomes TRUE again.

All parameters in this parameter group are array parameters with index 0 to 2. Select index 0 to program Timer 0, select index 1 to program Timer 1, and so on.

13-20 SL Controller Timer	
Range:	Function:
Size related* [0.000 - 0.000]	Enter the value to define the duration of the FALSE output from the programmed timer. A timer is only FALSE if it is started by an action (i.e. [29] <i>Start timer 1</i>) and until the given timer value has elapsed.

6.10.6 13-4* Logic Rules

Combine up to 3 boolean inputs (TRUE/FALSE inputs) from timers, comtors, digital inputs, status bits and events using the logical operators AND, OR, and NOT. Select boolean inputs for the calculation in *parameter 13-40 Logic Rule Boolean 1*, *parameter 13-42 Logic Rule Boolean 2* and *parameter 13-44 Logic Rule Boolean 3*. Define the operators used to logically combine the selected inputs in *parameter 13-41 Logic Rule Operator 1* and *parameter 13-43 Logic Rule Operator 2*.

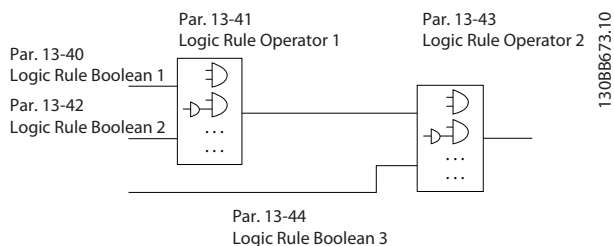

Figure 6.18 Logic Rules

Priority of calculation

The results of *parameter 13-40 Logic Rule Boolean 1*, *parameter 13-41 Logic Rule Operator 1* and *parameter 13-42 Logic Rule Boolean 2* are calculated first. The outcome (TRUE/FALSE) of this calculation is combined with the settings of *parameter 13-43 Logic Rule Operator 2* and *parameter 13-44 Logic Rule Boolean 3*, yielding the final result (TRUE/FALSE) of the logic rule.

13-40 Logic Rule Boolean 1		
Array [6]		
Option:	Function:	
[0]	FALSE	Select the first boolean (TRUE or FALSE) input for the selected logic rule. See <i>parameter 13-01 Start Event</i> ([0] - [61]) and <i>parameter 13-02 Stop Event</i> ([70] - [75]) for further description.
[1]	TRUE	
[2]	Running	
[3]	In range	
[4]	On reference	
[5]	Torque limit	
[6]	Current Limit	
[7]	Out of current range	
[8]	Below I low	
[9]	Above I high	
[10]	Out of speed range	
[11]	Below speed low	
[12]	Above speed high	
[13]	Out of feedb. range	
[14]	Below feedb. low	
[15]	Above feedb. high	
[16]	Thermal warning	
[17]	Mains out of range	
[18]	Reverse	
[19]	Warning	
[20]	Alarm (trip)	
[21]	Alarm (trip lock)	
[22]	Comparator 0	
[23]	Comparator 1	
[24]	Comparator 2	
[25]	Comparator 3	
[26]	Logic rule 0	
[27]	Logic rule 1	
[28]	Logic rule 2	
[29]	Logic rule 3	
[30]	SL Timeout 0	
[31]	SL Timeout 1	
[32]	SL Timeout 2	
[33]	Digital input DI18	
[34]	Digital input DI19	

13-40 Logic Rule Boolean 1		
Array [6]		
Option:	Function:	
[35]	Digital input DI27	
[36]	Digital input DI29	
[37]	Digital input DI32	
[38]	Digital input DI33	
[39]	Start command	
[40]	Drive stopped	
[41]	Reset Trip	
[42]	Auto-reset Trip	
[43]	OK key	
[44]	Reset key	
[45]	Left key	
[46]	Right key	
[47]	Up key	
[48]	Down key	
[50]	Comparator 4	
[51]	Comparator 5	
[60]	Logic rule 4	
[61]	Logic rule 5	
[70]	SL Timeout 3	
[71]	SL Timeout 4	
[72]	SL Timeout 5	
[73]	SL Timeout 6	
[74]	SL Timeout 7	
[75]	Start command given	
[76]	Digital input x30/2	
[77]	Digital input x30/3	
[78]	Digital input x30/4	
[79]	Digital input x46/1	
[80]	Digital input x46/3	
[81]	Digital input x46/5	
[82]	Digital input x46/7	
[83]	Digital input x46/9	
[84]	Digital input x46/11	
[85]	Digital input x46/13	
[90]	ATEX ETR cur. warning	Selectable if <i>parameter 1-90 Motor Thermal Protection</i> is set to [20] ATEX ETR or [21] Advanced ETR. If the alarm 164 ATEX ETR cur.lim.alarm is active, the output will be 1.
[91]	ATEX ETR cur. alarm	Selectable if <i>parameter 1-90 Motor Thermal Protection</i> is set to [20] ATEX ETR or [21] Advanced ETR. If the alarm 166 ATEX ETR freq.lim.alarm is active, the output will be 1.
[92]	ATEX ETR freq. warning	Selectable if <i>parameter 1-90 Motor Thermal Protection</i> is set to [20]

13-40 Logic Rule Boolean 1		
Array [6]		
Option:	Function:	
		ATEX ETR or [21] Advanced ETR. If the alarm 163 ATEX ETR cur.lim.warning is active, the output will be 1.
[93]	ATEX ETR freq. alarm	Selectable if <i>parameter 1-90 Motor Thermal Protection</i> is set to [20] ATEX ETR or [21] Advanced ETR. If the warning 165 ATEX ETR freq.lim.warning is active, the output will be 1.
[94]	RS Flipflop 0	See 13-1* Comparators
[95]	RS Flipflop 1	See 13-1* Comparators
[96]	RS Flipflop 2	See 13-1* Comparators
[97]	RS Flipflop 3	See 13-1* Comparators
[98]	RS Flipflop 4	See 13-1* Comparators
[99]	RS Flipflop 5	See 13-1* Comparators
[100]	RS Flipflop 6	See 13-1* Comparators
[101]	RS Flipflop 7	See 13-1* Comparators

13-41 Logic Rule Operator 1		
Array [6]		
Option:	Function:	
		Select the first logical operator to use on the Boolean inputs from <i>parameter 13-40 Logic Rule Boolean 1</i> and <i>parameter 13-42 Logic Rule Boolean 2</i> . [13-**] signifies the boolean input of parameter group 13-** <i>Smart Logic Control</i> .
[0]	DISABLED	Ignores <i>parameter 13-42 Logic Rule Boolean 2</i> , <i>parameter 13-43 Logic Rule Operator 2</i> , and <i>parameter 13-44 Logic Rule Boolean 3</i> .
[1]	AND	Evaluates the expression [13-40] AND [13-42].
[2]	OR	Evaluates the expression [13-40] OR [13-42].
[3]	AND NOT	Evaluates the expression [13-40] AND NOT [13-42].
[4]	OR NOT	Evaluates the expression [13-40] OR NOT [13-42].
[5]	NOT AND	Evaluates the expression NOT [13-40] AND [13-42].
[6]	NOT OR	Evaluates the expression NOT [13-40] OR [13-42].
[7]	NOT AND NOT	Evaluates the expression NOT [13-40] AND NOT [13-42].

13-41 Logic Rule Operator 1		
Array [6]		
Option:	Function:	
[8]	NOT OR NOT	Evaluates the expression NOT [13-40] OR NOT [13-42].

13-42 Logic Rule Boolean 2		
Array [6]		
Option:	Function:	
[0]	FALSE	Select the second boolean (TRUE or FALSE) input for the selected logic rule. See <i>parameter 13-01 Start Event</i> ([0] - [61]) and <i>parameter 13-02 Stop Event</i> ([70] - [75]) for further description.
[1]	TRUE	
[2]	Running	
[3]	In range	
[4]	On reference	
[5]	Torque limit	
[6]	Current Limit	
[7]	Out of current range	
[8]	Below I low	
[9]	Above I high	
[10]	Out of speed range	
[11]	Below speed low	
[12]	Above speed high	
[13]	Out of feedb. range	
[14]	Below feedb. low	
[15]	Above feedb. high	
[16]	Thermal warning	
[17]	Mains out of range	
[18]	Reverse	
[19]	Warning	
[20]	Alarm (trip)	
[21]	Alarm (trip lock)	
[22]	Comparator 0	
[23]	Comparator 1	
[24]	Comparator 2	
[25]	Comparator 3	
[26]	Logic rule 0	
[27]	Logic rule 1	
[28]	Logic rule 2	
[29]	Logic rule 3	
[30]	SL Timeout 0	
[31]	SL Timeout 1	
[32]	SL Timeout 2	
[33]	Digital input DI18	
[34]	Digital input DI19	
[35]	Digital input DI27	

13-42 Logic Rule Boolean 2		
Array [6]		
Option:	Function:	
[36]	Digital input DI29	
[37]	Digital input DI32	
[38]	Digital input DI33	
[39]	Start command	
[40]	Drive stopped	
[41]	Reset Trip	
[42]	Auto-reset Trip	
[43]	OK key	
[44]	Reset key	
[45]	Left key	
[46]	Right key	
[47]	Up key	
[48]	Down key	
[50]	Comparator 4	
[51]	Comparator 5	
[60]	Logic rule 4	
[61]	Logic rule 5	
[70]	SL Timeout 3	
[71]	SL Timeout 4	
[72]	SL Timeout 5	
[73]	SL Timeout 6	
[74]	SL Timeout 7	
[75]	Start command given	
[76]	Digital input x30/2	
[77]	Digital input x30/3	
[78]	Digital input x30/4	
[79]	Digital input x46/1	
[80]	Digital input x46/3	
[81]	Digital input x46/5	
[82]	Digital input x46/7	
[83]	Digital input x46/9	
[84]	Digital input x46/11	
[85]	Digital input x46/13	
[90]	ATEX ETR cur. warning	Selectable if <i>parameter 1-90 Motor Thermal Protection</i> is set to [20] <i>ATEX ETR</i> or [21] <i>Advanced ETR</i> . If the alarm 164 <i>ATEX ETR cur.lim.alarm</i> is active, the output will be 1.
[91]	ATEX ETR cur. alarm	Selectable if <i>parameter 1-90 Motor Thermal Protection</i> is set to [20] <i>ATEX ETR</i> or [21] <i>Advanced ETR</i> . If the alarm 166 <i>ATEX ETR freq.lim.alarm</i> is active, the output will be 1.
[92]	ATEX ETR freq. warning	Selectable if <i>parameter 1-90 Motor Thermal Protection</i> is set to [20] <i>ATEX ETR</i> or [21] <i>Advanced ETR</i> . If

13-42 Logic Rule Boolean 2		
Array [6]		
Option:	Function:	
		the alarm 163 ATEX ETR cur.lim.warning is active, the output will be 1.
[93]	ATEX ETR freq. alarm	Selectable if <i>parameter 1-90 Motor Thermal Protection</i> is set to [20] ATEX ETR or [21] Advanced ETR. If the warning 165 ATEX ETR freq.lim.warning is active, the output will be 1.
[94]	RS Flipflop 0	See 13-1* Comparators
[95]	RS Flipflop 1	See 13-1* Comparators
[96]	RS Flipflop 2	See 13-1* Comparators
[97]	RS Flipflop 3	See 13-1* Comparators
[98]	RS Flipflop 4	See 13-1* Comparators
[99]	RS Flipflop 5	See 13-1* Comparators
[100]	RS Flipflop 6	See 13-1* Comparators
[101]	RS Flipflop 7	See 13-1* Comparators

13-43 Logic Rule Operator 2		
Array [6]		
Option:	Function:	
		Select the second logical operator to be used on the boolean input calculated in <i>parameter 13-40 Logic Rule Boolean 1</i> , <i>parameter 13-41 Logic Rule Operator 1</i> , and <i>parameter 13-42 Logic Rule Boolean 2</i> , and the boolean input coming from <i>parameter 13-42 Logic Rule Boolean 2</i> . [13-44] signifies the boolean input of <i>parameter 13-44 Logic Rule Boolean 3</i> . [13-40/13-42] signifies the boolean input calculated in <i>parameter 13-40 Logic Rule Boolean 1</i> , <i>parameter 13-41 Logic Rule Operator 1</i> , and <i>parameter 13-42 Logic Rule Boolean 2</i> . [0] DISABLED (factory setting). select this option to ignore <i>parameter 13-44 Logic Rule Boolean 3</i> .
[0]	DISABLED	
[1]	AND	
[2]	OR	
[3]	AND NOT	
[4]	OR NOT	
[5]	NOT AND	
[6]	NOT OR	
[7]	NOT AND NOT	
[8]	NOT OR NOT	

13-44 Logic Rule Boolean 3		
Array [6]		
Option:	Function:	
[0]	FALSE	Select the third boolean (TRUE or FALSE) input for the selected logic rule. See <i>parameter 13-01 Start Event</i> ([0] - [61]) and <i>parameter 13-02 Stop Event</i> ([70] - [75]) for further description.
[1]	TRUE	
[2]	Running	
[3]	In range	
[4]	On reference	
[5]	Torque limit	
[6]	Current Limit	
[7]	Out of current range	
[8]	Below I low	
[9]	Above I high	
[10]	Out of speed range	
[11]	Below speed low	
[12]	Above speed high	
[13]	Out of feedb. range	
[14]	Below feedb. low	
[15]	Above feedb. high	
[16]	Thermal warning	
[17]	Mains out of range	
[18]	Reverse	
[19]	Warning	
[20]	Alarm (trip)	
[21]	Alarm (trip lock)	
[22]	Comparator 0	
[23]	Comparator 1	
[24]	Comparator 2	
[25]	Comparator 3	
[26]	Logic rule 0	
[27]	Logic rule 1	
[28]	Logic rule 2	
[29]	Logic rule 3	
[30]	SL Timeout 0	
[31]	SL Timeout 1	
[32]	SL Timeout 2	
[33]	Digital input DI18	
[34]	Digital input DI19	
[35]	Digital input DI27	
[36]	Digital input DI29	
[37]	Digital input DI32	
[38]	Digital input DI33	
[39]	Start command	
[40]	Drive stopped	
[41]	Reset Trip	
[42]	Auto-reset Trip	

13-44 Logic Rule Boolean 3		
Array [6]		
Option:	Function:	
[43]	OK key	
[44]	Reset key	
[45]	Left key	
[46]	Right key	
[47]	Up key	
[48]	Down key	
[50]	Comparator 4	
[51]	Comparator 5	
[60]	Logic rule 4	
[61]	Logic rule 5	
[70]	SL Timeout 3	
[71]	SL Timeout 4	
[72]	SL Timeout 5	
[73]	SL Timeout 6	
[74]	SL Timeout 7	
[75]	Start command given	
[76]	Digital input x30/2	
[77]	Digital input x30/3	
[78]	Digital input x30/4	
[79]	Digital input x46/1	
[80]	Digital input x46/3	
[81]	Digital input x46/5	
[82]	Digital input x46/7	
[83]	Digital input x46/9	
[84]	Digital input x46/11	
[85]	Digital input x46/13	
[90]	ATEX ETR cur. warning	Selectable if <i>parameter 1-90 Motor Thermal Protection</i> is set to [20] <i>ATEX ETR</i> or [21] <i>Advanced ETR</i> . If the alarm 164 ATEX ETR cur.lim.alarm is active, the output will be 1.
[91]	ATEX ETR cur. alarm	Selectable if <i>parameter 1-90 Motor Thermal Protection</i> is set to [20] <i>ATEX ETR</i> or [21] <i>Advanced ETR</i> . If the alarm 166 ATEX ETR freq.lim.alarm is active, the output will be 1.
[92]	ATEX ETR freq. warning	Selectable if <i>parameter 1-90 Motor Thermal Protection</i> is set to [20] <i>ATEX ETR</i> or [21] <i>Advanced ETR</i> . If the alarm 163 ATEX ETR cur.lim.warning is active, the output will be 1.
[93]	ATEX ETR freq. alarm	Selectable if <i>parameter 1-90 Motor Thermal Protection</i> is set to [20] <i>ATEX ETR</i> or [21] <i>Advanced ETR</i> . If the warning 165 ATEX ETR

13-44 Logic Rule Boolean 3		
Array [6]		
Option:	Function:	
		freq.lim.warning is active, the output will be 1.
[94]	RS Flipflop 0	See 13-1* Comparators
[95]	RS Flipflop 1	See 13-1* Comparators
[96]	RS Flipflop 2	See 13-1* Comparators
[97]	RS Flipflop 3	See 13-1* Comparators
[98]	RS Flipflop 4	See 13-1* Comparators
[99]	RS Flipflop 5	See 13-1* Comparators
[100]	RS Flipflop 6	See 13-1* Comparators
[101]	RS Flipflop 7	See 13-1* Comparators

6.10.7 13-5* States

13-51 SL Controller Event		
Array [20]		
Option:	Function:	
[0]	FALSE	Select the boolean input (TRUE or FALSE) to define the Smart Logic Controller event. See <i>parameter 13-01 Start Event</i> ([0] - [61]) and <i>parameter 13-02 Stop Event</i> ([70] - [74]) for further description.
[1]	TRUE	
[2]	Running	
[3]	In range	
[4]	On reference	
[5]	Torque limit	
[6]	Current Limit	
[7]	Out of current range	
[8]	Below I low	
[9]	Above I high	
[10]	Out of speed range	
[11]	Below speed low	
[12]	Above speed high	
[13]	Out of feedb. range	
[14]	Below feedb. low	
[15]	Above feedb. high	
[16]	Thermal warning	
[17]	Mains out of range	
[18]	Reverse	
[19]	Warning	
[20]	Alarm (trip)	
[21]	Alarm (trip lock)	

13-51 SL Controller Event		
Array [20]		
Option:	Function:	
[22]	Comparator 0	
[23]	Comparator 1	
[24]	Comparator 2	
[25]	Comparator 3	
[26]	Logic rule 0	
[27]	Logic rule 1	
[28]	Logic rule 2	
[29]	Logic rule 3	
[30]	SL Timeout 0	
[31]	SL Timeout 1	
[32]	SL Timeout 2	
[33]	Digital input DI18	
[34]	Digital input DI19	
[35]	Digital input DI27	
[36]	Digital input DI29	
[37]	Digital input DI32	
[38]	Digital input DI33	
[39]	Start command	
[40]	Drive stopped	
[41]	Reset Trip	
[42]	Auto-reset Trip	
[43]	OK key	
[44]	Reset key	
[45]	Left key	
[46]	Right key	
[47]	Up key	
[48]	Down key	
[50]	Comparator 4	
[51]	Comparator 5	
[60]	Logic rule 4	
[61]	Logic rule 5	
[70]	SL Timeout 3	
[71]	SL Timeout 4	
[72]	SL Timeout 5	
[73]	SL Timeout 6	
[74]	SL Timeout 7	
[75]	Start command given	
[76]	Digital input x30/2	
[77]	Digital input x30/3	
[78]	Digital input x30/4	
[79]	Digital input x46/1	
[80]	Digital input x46/3	
[81]	Digital input x46/5	
[82]	Digital input x46/7	
[83]	Digital input x46/9	
[84]	Digital input x46/11	
[85]	Digital input x46/13	

13-51 SL Controller Event		
Array [20]		
Option:	Function:	
[90]	ATEX ETR cur. warning	Selectable if <i>parameter 1-90 Motor Thermal Protection</i> is set to [20] ATEX ETR or [21] Advanced ETR. If the alarm 164 ATEX ETR cur.lim.alarm is active, the output will be 1.
[91]	ATEX ETR cur. alarm	Selectable if <i>parameter 1-90 Motor Thermal Protection</i> is set to [20] ATEX ETR or [21] Advanced ETR]. If the alarm 166 ATEX ETR freq.lim.alarm is active, the output will be 1.
[92]	ATEX ETR freq. warning	Selectable if <i>parameter 1-90 Motor Thermal Protection</i> is set to [20] ATEX ETR or [21] Advanced ETR. If the alarm 163 ATEX ETR cur.lim.warning is active, the output will be 1.
[93]	ATEX ETR freq. alarm	Selectable if <i>parameter 1-90 Motor Thermal Protection</i> is set to [20] ATEX ETR or [21] Advanced ETR. If the warning 165 ATEX ETR freq.lim.warning is active, the output will be 1.
[94]	RS Flipflop 0	See 13-1* Comparators
[95]	RS Flipflop 1	See 13-1* Comparators
[96]	RS Flipflop 2	See 13-1* Comparators
[97]	RS Flipflop 3	See 13-1* Comparators
[98]	RS Flipflop 4	See 13-1* Comparators
[99]	RS Flipflop 5	See 13-1* Comparators
[100]	RS Flipflop 6	See 13-1* Comparators
[101]	RS Flipflop 7	See 13-1* Comparators

13-52 SL Controller Action		
Array [20]		
Option:	Function:	
[0]	DISABLED	Select the action corresponding to the SLC event. Actions are executed when the corresponding event (defined in <i>parameter 13-51 SL Controller Event</i>) is evaluated as true. The following actions are available for selection: [0] *DISABLED
[1]	No action	

13-52 SL Controller Action		
Array [20]		
	Option:	Function:
[2]	Select set-up 1	Changes the active set-up (<i>parameter 0-10 Active Set-up</i>) to '1'. If the set-up is changed, it will merge with other set-up commands coming from either the digital inputs or via a fieldbus.
[3]	Select set-up 2	Changes the active set-up (<i>parameter 0-10 Active Set-up</i>) to '2'. If the set-up is changed, it will merge with other set-up commands coming from either the digital inputs or via a fieldbus.
[4]	Select set-up 3	Changes the active set-up (<i>parameter 0-10 Active Set-up</i>) to '3'. If the set-up is changed, it will merge with other set-up commands coming from either the digital inputs or via a fieldbus.
[5]	Select set-up 4	Changes the active set-up (<i>parameter 0-10 Active Set-up</i>) to '4'. If the set-up is changed, it will merge with other set-up commands coming from either the digital inputs or via a fieldbus.
[10]	Select preset ref 0	Selects preset reference 0. If the active preset reference is changed, it will merge with other preset reference commands coming from either the digital inputs or via a fieldbus.
[11]	Select preset ref 1	Selects preset reference 1. If the active preset reference is changed, it will merge with other preset reference commands coming from either the digital inputs or via a fieldbus.
[12]	Select preset ref 2	Selects preset reference 2. If the active preset reference is changed, it will merge with other preset reference commands coming from either the digital inputs or via a fieldbus.
[13]	Select preset ref 3	Selects preset reference 3. If the active preset reference is changed, it will merge with other preset reference commands coming from either the digital inputs or via a fieldbus.
[14]	Select preset ref 4	Selects preset reference 4. If the active preset reference is changed, it will merge with other preset reference commands coming from either the digital inputs or via a fieldbus.
[15]	Select preset ref 5	Selects preset reference 5.

13-52 SL Controller Action		
Array [20]		
	Option:	Function:
		If the active preset reference is changed, it will merge with other preset reference commands coming from either the digital inputs or via a fieldbus.
[16]	Select preset ref 6	Selects preset reference 6. If the active preset reference is changed, it will merge with other preset reference commands coming from either the digital inputs or via a fieldbus.
[17]	Select preset ref 7	Selects preset reference 7. If the active preset reference is changed, it will merge with other preset reference commands coming from either the digital inputs or via a fieldbus.
[18]	Select ramp 1	Selects ramp 1.
[19]	Select ramp 2	Selects ramp 2.
[20]	Select ramp 3	Selects ramp 3.
[21]	Select ramp 4	Selects ramp 4.
[22]	Run	Issues a start command to the frequency converter.
[23]	Run reverse	Issues a start reverse command to the frequency converter.
[24]	Stop	Issues a stop command to the frequency converter.
[25]	Qstop	Issues a quick stop command to the frequency converter.
[26]	Dcstop	Issues a DC stop command to the frequency converter.
[27]	Coast	The frequency converter coasts immediately. All stop commands including the coast command stop the SLC.
[28]	Freeze output	Freezes the output frequency of the frequency converter.
[29]	Start timer 0	Starts timer 0, see <i>parameter 13-20 SL Controller Timer</i> for further description.
[30]	Start timer 1	Starts timer 1, see <i>parameter 13-20 SL Controller Timer</i> for further description.
[31]	Start timer 2	Starts timer 2, see <i>parameter 13-20 SL Controller Timer</i> for further description.
[32]	Set digital out A low	Any output with SL output A will be low.
[33]	Set digital out B low	Any output with SL output B will be low.

13-52 SL Controller Action		
Array [20]		
Option:	Function:	
[34]	Set digital out C low	Any output with SL output C will be low.
[35]	Set digital out D low	Any output with SL output D will be low.
[36]	Set digital out E low	Any output with SL output E will be low.
[37]	Set digital out F low	Any output with SL output F will be low.
[38]	Set digital out A high	Any output with SL output A will be high.
[39]	Set digital out B high	Any output with SL output B will be high.
[40]	Set digital out C high	Any output with SL output C will be high.
[41]	Set digital out D high	Any output with SL output D will be high.
[42]	Set digital out E high	Any output with SL output E will be high.
[43]	Set digital out F high	Any output with SL output F will be high.
[60]	Reset Counter A	Resets Counter A to zero.
[61]	Reset Counter B	Resets Counter B to zero.
[70]	Start timer 3	Start Timer 3, see <i>parameter 13-20 SL Controller Timer</i> for further description.
[71]	Start timer 4	Start Timer 4, see <i>parameter 13-20 SL Controller Timer</i> for further description.
[72]	Start timer 5	Start Timer 5, see <i>parameter 13-20 SL Controller Timer</i> for further description.
[73]	Start timer 6	Start Timer 6, see <i>parameter 13-20 SL Controller Timer</i> for further description.
[74]	Start timer 7	Start Timer 7, see <i>parameter 13-20 SL Controller Timer</i> for further description.

6.11 Par. Group 14 - Special Functions

6.11.1 14-** Special Functions

Parameter group for configuring special frequency converter functions.

6.11.2 14-0* Inverter Switching

Parameters for configuring the inverter switching.

14-03 Overmodulation

Option: Function:

[0]	Off	Connect the overmodulation function for the output voltage, to obtain an output voltage up to 15% greater than the mains voltage.
[1] *	On	No overmodulation of the output voltage, in order to avoid torque ripple on the motor shaft. This feature may be useful for applications such as grinding machines.

6.11.3 14-1* Mains On/Off

Parameters for configuring mains failure monitoring and handling.

14-12 Function at Line Imbalance

Option: Function:

		Operation under severe line imbalance conditions reduces the lifetime of the motor. Conditions are considered severe if the motor is operated continuously near nominal load.
[0]	Trip	Trips the adjustable frequency drive.
[1] *	Warning	Issues a warning.
[2]	Disabled	No action

6.11.4 14-2* Trip Reset

Parameters for configuring auto reset handling, special trip handling and control card self test or initialisation.

14-20 Reset Mode

Option: Function:

		Select the reset function after tripping. Once reset, the frequency converter can be restarted.
[0]	Manual reset	Performs a reset via [Reset] or via the digital inputs.
[10] *	Automatic reset x 10	Performs between one and twenty automatic resets after tripping.

NOTICE!

If the specified number of AUTOMATIC RESETS is reached within 10 minutes, the frequency converter enters [0] Manual reset mode. After the Manual reset is performed, the setting of parameter 14-20 Reset Mode reverts to the original selection. If the number of AUTOMATIC RESETS is not reached within 10 minutes, or when a Manual reset is performed, the internal AUTOMATIC RESET counter returns to zero.

CAUTION

The motor may start without warning.

Application Tip:

Since the default setting of the reset mode in the compressor drive is set up to auto-reset after 30 s this should be taken in consideration if a relay output is set to call for a service technician in case of an alarm. By setting 5-40 Function Relay to [9] Alarm and 5-41 On Delay, Relay to 40 s the relay will only activate at either a trip lock alarm or an alarm, which could not be auto-reset. Only the relay output can be used for this; the digital outputs do not have the On Delay feature.

14-21 Automatic Restart Time

Range: Function:

30 s*	[0 - 600 s]	Enter the time interval from trip to start of the automatic reset function. This parameter is active when parameter 14-20 Reset Mode is set to Automatic reset.
-------	-------------	---

14-22 Operation Mode

Option: Function:

		Use this parameter to specify normal operation; to perform tests; or to initialize all parameters except parameter 15-03 Power Up's, parameter 15-04 Over Temp's and parameter 15-05 Over Volt's. This function is active only when the power is cycled to the frequency converter.
[0] *	Normal operation	Normal operation of the frequency converter with the motor in the selected application.
[1]	Control card test	Tests the analog and digital inputs and outputs and the +10 V control voltage. The test requires a test connector with internal connections. Use the following procedure for the control card test: <ol style="list-style-type: none"> Select Control card test [1]. Disconnect the mains supply and wait for the light in the display to go out.

14-22 Operation Mode

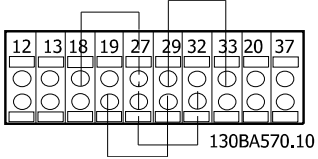
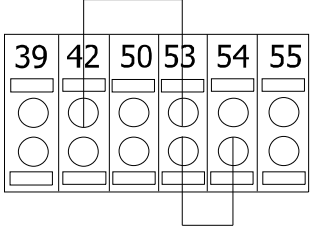
Option:	Function:
	<ol style="list-style-type: none"> 3. Set switches S201 (A53) and S202 (A54) = ON./I. 4. Insert the test plug (see below). 5. Connect to mains supply. 6. Carry out various tests. 7. The results are displayed on the LCP and the frequency converter moves into an infinite loop. 8. <i>Parameter 14-20 Reset Mode</i> is automatically set to Normal operation. Carry out a power cycle to start up in Normal operation after a control card test. <p>If the test is OK: LCP read-out: Control Card OK. Disconnect the mains supply and remove the test plug. The green LED on the Control Card will light up.</p> <p>If the test fails: LCP read-out: Control Card I/O failure. Replace the frequency converter or Control card. The red LED on the Control Card is turned on. Test plugs (connect the following terminals to each other): 18 - 27 - 32; 19 - 29 - 33; 42 - 53 - 54 1.</p> <div style="text-align: center;">  <p>130BA570.10</p> </div> <p>Figure 6.19</p> <div style="text-align: center;">  <p>130BA571.10</p> </div> <p>Figure 6.20</p>
[2] initialization	Resets all parameter values to default settings, except for <i>parameter 15-03 Power Up's</i> , <i>parameter 15-04 Over Temp's</i> and

14-22 Operation Mode

Option:	Function:
	<i>parameter 15-05 Over Volt's</i> . The frequency converter will reset during the next power-up. <i>Parameter 14-20 Reset Mode</i> will also revert to the default setting [0] Normal operation.

14-52 Fan Control

Option:	Function:
	Select the minimum speed of the internal fan.
[0] * Auto	Runs the fan only when the internal temperature of the frequency converter is in the range 35 °C . approx. 55 °C. The fan will run at low speed at 35 °C, and at full speed at approx. 55 °C.
[1] On 50%	
[2] On 75%	
[3] On 100%	

14-53 Fan Monitor

Option:	Function:
	Select which reaction the frequency converter should take in case a fan fault is detected.
[0] Disabled	
[1] Warning	
[2] Trip	

14-60 Function at Over Temperature

Option:	Function:
	If either heatsink or control card temperature exceeds a factory-programmed temperature limit, a warning will be activated. If the temperature increases further, select whether the frequency converter should trip (trip locked) or derate the output current.
[0] Trip	The frequency converter will trip (trip locked) and generate an alarm. Power must be cycled to reset the alarm, but will not allow restart of the motor until the heat sink temperature has dropped below the alarm limit.
[1] * Derate	If the critical temperature is exceeded the output current will be reduced until the allowable temperature has been reached.

14-61 Function at Inverter Overload

Option:	Function:
	Is used in case of steady overload beyond the thermal limits (110% for 60 sec.).
[0] Trip	The frequency converter trips and provides an alarm.
[1] * Derate	Reduce pump speed to decrease the load on the power section and allowing this to cool down.

14-62 Inv. Overload Derate Current		
Range:		Function:
95 %*	[50 - 100 %]	Defines the desired current level (in % of rated output current for the frequency converter) when running with reduced pump speed after load on the frequency converter has exceeded the allowable limit (110% for 60 s).

14-90 Fault Level		
Option:		Function:
[0]	Off	Use this parameter to customize Fault levels. Use [0] Off with caution as it will ignore all Warnings & Alarms for the chosen source.
[1]	Warning	
[2]	Trip	
[3]	Trip Lock	

Failure	Alarm	Off	Warning	Trip	Trip Lock
Over Current	13			D	X
Motor phase missing	30			D	X
Motor phase missing	31			D	X
Motor phase missing	32			D	X

Table 6.10 Table for Selection of Choice of Action when Selected Alarm Appears

D = Default setting. x = possible selection.

1) Only high power drives

In FC small and medium A69 is only a warning

6.12 Par. Group 15 - Drive Information

6.12.1 15-** Drive Information

Parameter group containing compressor drive information such as

- operating data
- hardware configuration
- software versions

6.12.2 15-0* Operating data

Parameter group containing operating data, e.g. counters.

15-00 Operating hours		
Range:	Function:	
0 h*	[0 - 2147483647 h]	View how many hours the frequency converter has run. The value is saved when the frequency converter is turned off.

15-01 Running Hours		
Range:	Function:	
0 h*	[0 - 2147483647 h]	View how many hours the motor has run. Reset the counter in <i>parameter 15-07 Reset Running Hours Counter</i> . The value is saved when the frequency converter is turned off.

15-02 kWh Counter		
Range:	Function:	
0 kWh*	[0 - 2147483647 kWh]	Registering the power consumption of the motor as a mean value over one hour. Reset the counter in <i>parameter 15-06 Reset kWh Counter</i> .

15-03 Power-ups		
Range:	Function:	
0 *	[0 - 2147483647]	View the number of times the frequency converter has been powered up.

15-04 Over Temps		
Range:	Function:	
0 *	[0 - 65535]	View the number of frequency converter temperature faults which have occurred.

15-05 Over Volts		
Range:	Function:	
0 *	[0 - 65535]	View the number of frequency converter overvoltages which have occurred.

15-06 Reset kWh Counter		
Option:	Function:	
[0]	Do not reset	No reset of the kWh counter is desired.
[1]	Reset counter	Press [OK] to reset the kWh counter to zero (see <i>parameter 15-02 kWh Counter</i>).

NOTICE!

The reset is carried out by pressing [OK].

15-07 Reset Running Hours Counter		
Option:	Function:	
[0]	Do not reset	
[1]	Reset counter	Select [1] <i>Reset</i> and press [OK] to reset the Running Hours counter to zero (see <i>parameter 15-01 Running Hours</i>). This parameter cannot be selected via the serial port, RS-485. Select [0] <i>Do not reset</i> if no reset of the Running Hours counter is desired.

15-08 Number of Starts		
Range:	Function:	
[0 - 4294967295]	View the total number of starts performed since power-on. The value is cleared to zero at power-up.	

15-09 Number of Auto Resets		
Range:	Function:	
[0 - 4294967295]	View the total number of auto resets performed since power-on. The counter is cleared to zero at power-up.	

6.13 Parameters: 16-** Data Readouts

16-00 Control Word		
Range:	Function:	
0 * [0 - 65535]	View the Control word sent from the frequency converter via the serial communication port in hex code.	

16-01 Reference [Unit]		
Range:	Function:	
0 ReferenceFeed-backUnit*	[-999999 - 999999 ReferenceFeed-backUnit]	View the present reference value applied on impulse or analog basis in the unit resulting from the configuration selected in <i>parameter 1-00 Configuration Mode</i> (Hz, Nm, or RPM).

16-02 Reference [%]		
Range:	Function:	
0 %* [-200 - 200 %]	View the total reference. The total reference is the sum of digital, analog, preset, bus, and freeze references, plus catch-up and slow-down.	

16-03 Status Word		
Range:	Function:	
0 * [0 - 65535]	View the status word sent from the frequency converter via the serial communication port in hex code.	

16-05 Main Actual Value [%]		
Range:	Function:	
0 %* [-100 - 100 %]	View the two-byte word sent with the status word to the Bus Master reporting the Main Actual Value.	

16-09 Custom Readout		
Range:	Function:	
0 CustomReadoutUnit*	[0 - 0 CustomReadoutUnit]	View the value of custom readout from <i>parameter 0-30 Unit for User-defined Readout</i> to <i>parameter 0-32 Custom Readout Max Value</i>

6.13.1 16-1* Motor Status

16-10 Power [kW]		
Range:	Function:	
0 kW* [0 - 10000 kW]	Displays motor power in kW. The value shown is calculated based on the actual motor voltage and motor current. The value is filtered, and therefore approx. 30 ms may pass from when an input value changes to when the data readout values change. The resolution of readout value on fieldbus is in 10 W steps.	

16-11 Power [hp]		
Range:	Function:	
0 hp* [0 - 10000 hp]	View the motor power in hp. The value shown is calculated based on the actual motor voltage and motor current. The value is filtered, and therefore approximately 30 ms may pass from when an input value changes to when the data readout values change.	

16-12 Motor voltage		
Range:	Function:	
0 V* [0 - 6000 V]	View the motor voltage, a calculated value used for controlling the motor.	

16-13 Frequency		
Range:	Function:	
0 Hz* [0 - 6500 Hz]	View the motor frequency, without resonance dampening.	

16-14 Motor current		
Range:	Function:	
0 A* [0 - 10000 A]	View the motor current measured as a mean value, I_{RMS} . The value is filtered, and thus approximately 30 ms may pass from when an input value changes to when the data readout values change.	

16-15 Frequency [%]		
Range:	Function:	
0 %* [-100 - 100 %]	View a two-byte word reporting the actual motor frequency (without resonance dampening) as a percentage (scale 0000-4000 Hex) of <i>parameter 4-19 Max Output Frequency</i> . Set <i>parameter 9-16 PCD Read Configuration</i> index 1 to send it with the status word instead of the MAV.	

16-16 Torque [Nm]		
Range:		Function:
0 Nm*	[-3000 - 3000 Nm]	View the torque value with sign, applied to the motor shaft. Linearity is not exact between 160% motor current and torque in relation to the rated torque. Some motors supply more than 160% torque. Consequently, the min. value and the max. value depend on the max. motor current as well as the motor used. The value is filtered, and thus approx. 30 ms may pass from when an input changes value to when the data readout values change.

16-17 Speed [RPM]		
Range:		Function:
0 RPM*	[-30000 - 30000 RPM]	View the actual motor RPM. In open loop or closed loop process control, the motor RPM is estimated. In speed closed loop modes the motor RPM is measured.

16-18 Motor Thermal		
Range:		Function:
0 %*	[0 - 100 %]	View the calculated thermal load on the motor. The cut-out limit is 100%. The basis for calculation is the ETR function selected in <i>parameter 1-90 Motor Thermal Protection</i> .

16-19 KTY sensor temperature		
Range:		Function:
0 °C*	[0 - 0 °C]	Returning the actual temperature on KTY sensor built into the motor. See parameter group <i>1-9* Motor Temperature</i> .

16-20 Motor Angle		
Range:		Function:
0 *	[0 - 65535]	View the current encoder/resolver angle offset relative to the index position. The value range of 0-65535 corresponds to 0-2*pi (radians).

16-21 Torque [%] High Res.		
Range:		Function:
0 %*	[-200 - 200 %]	The value shown is the torque in percent of nominal torque, with sign and 0.1% resolution, applied to the motor shaft.

16-22 Torque [%]		
Range:		Function:
0 %*	[-200 - 200 %]	Value shown is the torque in percent of nominal torque, with sign, applied to the motor shaft.

16-25 Torque [Nm] High		
Range:		Function:
0 Nm*	[-200000000 - 200000000 Nm]	View the torque value with sign, applied to the motor shaft. Some motors supply more than 160% torque. Consequently, the min. value and the max. value depend on the max. motor current as well as the motor used. This specific readout has been adapted to be able to show higher values than the standard readout in <i>parameter 16-16 Torque [Nm]</i> .

6.13.2 16-3* Drive Status

16-30 DC Link Voltage		
Range:		Function:
0 V*	[0 - 10000 V]	View a measured value. The value is filtered with a 30 ms time constant.

16-32 Brake Energy /s		
Range:		Function:
0 kW*	[0 - 10000 kW]	View the brake power transmitted to an external brake resistor, stated as an instantaneous value.

16-33 Brake Energy /2 min		
Range:		Function:
0 kW*	[0 - 10000 kW]	View the brake power transmitted to an external brake resistor. The mean power is calculated on an average basis for the most recent 120 s.

16-34 Heatsink Temp.		
Range:		Function:
0 °C*	[0 - 255 °C]	View the frequency converter heatsink temperature. The cut-out limit is 90 ±5 °C, and the motor cuts back in at 60 ±5 °C.

16-35 Inverter Thermal		
Range:		Function:
0 %*	[0 - 100 %]	View the percentage load on the inverter.

16-36 Inv. Nom. Current		
Range:		Function:
Size related*	[0.01 - 10000 A]	View the inverter nominal current, which must match the nameplate data on the connected motor. The data are used for calculation of torque, motor protection, etc.

16-37 Inv. Max. Current		
Range:		Function:
Size related*	[0.01 - 10000 A]	View the inverter maximum current, which must match the nameplate data on the connected motor. The data are used for calculation of torque, motor protection, etc.

16-38 SL Controller State		
Range:		Function:
0 *	[0 - 100]	View the state of the event under execution by the SL controller.

16-39 Control Card Temp.		
Range:		Function:
0 °C*	[0 - 100 °C]	View the temperature on the control card, stated in °C

16-40 Logging Buffer Full		
Option: Function:		
		View whether the logging buffer is full (see parameter group 15-1* <i>Data Log Settings</i>). The logging buffer is never full when setting <i>parameter 15-13 Logging Mode</i> to [0] <i>Log always</i> .
[0]	No	
[1]	Yes	

16-48 Speed Ref. After Ramp [RPM]		
Range:		Function:
0 RPM*	[-30000 - 30000 RPM]	This parameter specifies the reference given to the frequency converter after the speed ramp.

16-52 Feedback [Unit]		
Range:		Function:
0 Reference-FeedbackUnit*	[-999999.999 - 999999.999 ReferenceFeed-backUnit]	View the feedback unit resulting from the selection of unit and scaling in <i>parameter 3-00 Reference Range</i> , <i>parameter 3-01 Reference/Feedback Unit</i> , <i>parameter 3-02 Minimum Reference</i> and <i>parameter 3-03 Maximum Reference</i> .

16-53 Digi Pot Reference		
Range:		Function:
0 *	[-200 - 200]	View the contribution of the Digital Potentiometer to the actual reference.

16-57 Feedback [RPM]		
Range:		Function:
0 RPM*	[-30000 - 30000 RPM]	Readout parameter where the actual motor RPM from the feedback source can be read in both closed loop and open loop. Select the feedback source in <i>parameter 7-00 Speed PID Feedback Source</i> .

6.13.3 16-5* Ref. & Feedb.

16-50 External Reference		
Range:		Function:
0 *	[-200 - 200]	View the total reference, the sum of digital, analog, preset, bus and freeze references, plus catch-up and slow-down.

16-51 Pulse Reference		
Range:		Function:
0 *	[-200 - 200]	View the reference value from programmed digital input(s). The readout can also reflect the impulses from an incremental encoder.

6.13.4 16-6* Inputs and Outputs

16-60 Digital Input		
Range:	Function:	
0 * [0 - 1023]	View the signal states from the active digital inputs. Example: Input 18 corresponds to bit no. 5, '0' = no signal, '1' = connected signal. Bit 6 works in the opposite way, on = '0', off = '1' (safe stop input).	
Bit 0	Digital input term. 33	
Bit 1	Digital input term. 32	
Bit 2	Digital input term. 29	
Bit 3	Digital input term. 27	
Bit 4	Digital input term. 19	
Bit 5	Digital input term. 18	
Bit 6	Digital input term. 37	
Bit 7	Digital input GP I/O term. X30/4	
Bit 8	Digital input GP I/O term. X30/3	
Bit 9	Digital input GP I/O term. X30/2	
Bit 10-63	Reserved for future terminals	

0 0	<ul style="list-style-type: none"> DI T -33 DI T -32 DI T -29 DI T -27 DI T -19 DI T -18 DI T -37 DI X30/4 DI X30/3 DI X30/2 DI X46/13 DI X46/11 DI X46/9 DI X46/7 DI X46/5 DI X46/3 DI X46/1
---	--

Figure 6.21 Relay Settings

16-61 Terminal 53 Switch Setting		
Option:	Function:	
	View the setting of input terminal 53.	
[0]	Current	
[1]	Voltage	

16-62 Analog Input 53		
Range:	Function:	
0 * [-20 - 20]	View the actual value at input 53.	

16-63 Terminal 54 Switch Setting		
Option:	Function:	
	View the setting of input terminal 54.	
[0]	Current	
[1]	Voltage	

16-64 Analog Input 54		
Range:	Function:	
0 * [-20 - 20]	View the actual value at input 54.	

16-65 Analog Output 42 [mA]		
Range:	Function:	
0 * [0 - 30]	View the actual value at output 42 in mA. The value shown reflects the selection in parameter 6-50 Terminal 42 Output.	

16-66 Digital Output [bin]		
Range:	Function:	
0 * [0 - 15]	View the binary value of all digital outputs.	

16-67 Pulse Input #29 [Hz]		
Range:	Function:	
0 * [0 - 130000]	View the actual frequency rate on terminal 29.	

16-68 Freq. Input #33 [Hz]		
Range:	Function:	
0 * [0 - 130000]	View the actual value of the frequency applied at terminal 33 as an impulse input.	

16-69 Pulse Output #27 [Hz]		
Range:	Function:	
0 * [0 - 40000]	View the actual value of pulses applied to terminal 27 in digital output mode.	

16-70 Pulse Output #29 [Hz]		
Range:	Function:	
0 * [0 - 40000]	View the actual value of pulses at terminal 29 in digital output mode.	

16-71 Relay Output [bin]		
Range:	Function:	
0 * [0 - 511]	View the settings of all relays.	

<p>Readout choice (Par. 16-71): Relay output (bin):</p> <p>0 0 0 0 bin</p>	130BA195.10
--	-------------

Figure 6.23 Relay Settings

16-72 Counter A		
Range:	Function:	
0 * [-2147483648 - 2147483647]	View the present value of Counter A. Counters are useful as comparator operands, see <i>parameter 13-10 Comparator Operand</i> . The value can be reset or changed either via digital inputs (parameter group 5-1* <i>Digital Inputs</i>) or by using an SLC action (<i>parameter 13-52 SL Controller Action</i>).	

16-73 Counter B		
Range:	Function:	
0 * [-2147483648 - 2147483647]	View the present value of Counter B. Counters are useful as comparator operands (<i>parameter 13-10 Comparator Operand</i>). The value can be reset or changed either via digital inputs (parameter group 5-1* <i>Digital Inputs</i>) or by using an SLC action (<i>parameter 13-52 SL Controller Action</i>).	

16-74 Prec. Stop Counter		
Range:	Function:	
0 * [0 - 2147483647]	Returns the actual counter value of precise counter (<i>parameter 1-84 Precise Stop Counter Value</i>).	

6.13.5 16-8* Fieldbus & FC Port

Parameters for reporting the BUS references and control words.

16-80 Fieldbus CTW 1		
Range:	Function:	
0 * [0 - 65535]	View the two-byte control word (CTW) received from the Bus-Master. Interpretation of the control word depends on the fieldbus option installed and the control word profile selected in <i>parameter 8-10 Control Profile</i> . For more information, refer to the relevant fieldbus manual.	

16-82 Fieldbus REF 1		
Range:	Function:	
0 * [-200 - 200]	View the two-byte word sent with the control word from the Bus-Master to set the reference value. For more information, refer to the relevant fieldbus manual.	

16-84 Comm. Option Status		
Range:	Function:	
0 * [0 - 65535]	View the extended fieldbus comm. option status word. For more information, refer to the relevant fieldbus manual.	

16-86 FC Port REF 1		
Range:	Function:	
0 * [-200 - 200]	View the two-byte status word (STW) sent to the Bus-Master. Interpretation of the status word depends on the fieldbus option installed and the control word profile selected in <i>parameter 8-10 Control Profile</i> .	

16-86 FC Port REF 1		
Range:	Function:	
0 * [-200 - 200]	View the two-byte status word (STW) sent to the bus master. Interpretation of the status word depends on the serial communication bus option installed and the control word profile selected in <i>parameter 8-10 Control Profile</i> .	

6.13.6 16-9* Diagnosis Read-Outs

NOTICE!

When using MCT 10 Set-up Software, the readout parameters can only be read online, i.e. as the actual status. This means that the status is not stored in the MCT 10 Set-up Software file.

16-90 Alarm Word		
Range:	Function:	
0 * [0 - 4294967295]	View the alarm word sent via the serial communication port in hex code.	

16-91 Alarm Word 2		
Range:	Function:	
0 * [0 - 4294967295]	View the alarm word sent via the serial communication port in hex code.	

16-92 Warning Word		
Range:	Function:	
0 * [0 - 4294967295]	View the warning word sent via the serial communication port in hex code.	

16-93 Warning Word 2		
Range:	Function:	
0 * [0 - 4294967295]	View the warning word sent via the serial communication port in hex code.	

16-94 Ext. Status Word		
Range:		Function:
0 *	[0 - 4294967295]	Returns the extended warning word sent via the serial communication port in hex code.

16-95 Ext. Status Word 2		
Range:		Function:
0 *	[0 - 4294967295]	Returns the extended warning word 2 sent via the serial communication port in hex code.

6.14 Par. Group 25 - Cascade Controller

Parameters for configuring the Basic Cascade Controller for sequence control of multiple compressors.

To configure the Cascade Controller to the actual system and the desired control strategy, it is recommended to follow the below sequence, starting with parameter group 25-0* *System Settings*, and next parameter group 25-5* *Alternation Settings*. These parameters can normally be set in advance.

Parameters in parameter group 25-2* *Bandwidth Settings* and 25-4* *Staging settings* will often be dependent on the dynamic of the system and final adjustment to be done at the commissioning of the plant.

NOTICE!

The Cascade Controller is supposed to operate in closed loop controlled by the built-in PI controller ([1] *Speed Closed Loop* selected in *parameter 1-00 Configuration Mode*). If [0] *Speed Open Loop* is selected in *parameter 1-00 Configuration Mode*, all fixed speed compressors will be destaged, but the variable speed compressor will still be controlled by the frequency converter, now as an open loop configuration:

6

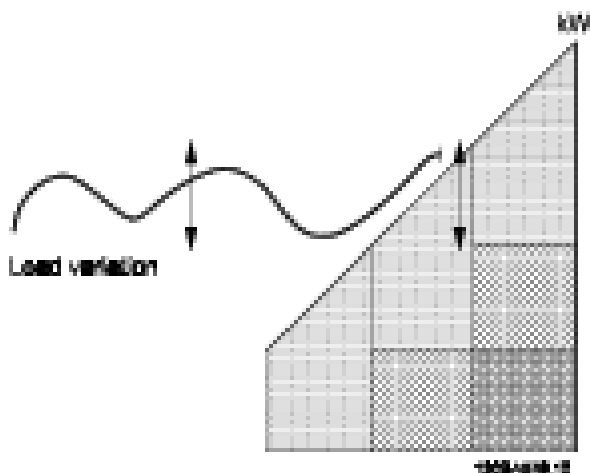

Figure 6.24 Cascade Controller Feedback Signals



Figure 6.25 Configuring the Cascade Controller

6.14.1 25-0* System Settings

Parameters related to control principles and configuration of the system.

25-00 Cascade Controller

Option:	Function:
	For operation of multiple devices (compressor) systems where capacity is adapted to actual load by means of speed control combined with on/off control of the devices. For simplicity only compressor systems are described.
[0] * Disabled	The Cascade Controller is not active. All built-in relays assigned to compressor motors in the cascade function will be de-energized. If a variable speed compressor is connected to the frequency converter directly (not controlled by a built-in relay), this compressor will be controlled as a single compressor system.
[1] Enabled	The Cascade Controller is active and will stage/destage compressors according to load on the system.

NOTICE!

This parameter can only be [1] Enabled, if parameter 22-75 Short Cycle Protection is set to [0] Disabled.

25-02 Motor Start

Option:	Function:
	Motors are connected to the mains directly with a contactor or with a soft starter. When the value of parameter 25-02 Motor Start is set to an option other than [0] Direct on Line, then parameter 25-50 Lead Compressor Alternation is automatically set to the default of [0] Direct on Line.
[0] * Direct on Line	Each fixed speed compressor is connected to line directly via a contactor.
[1] Soft starter	Each fixed speed compressor is connected to line via a soft starter.

25-04 Compressor Cycling

Option:	Function:
	To provide equal hours of operation with fixed speed compressors, the compressor use can be cycled. The selection of compressor cycling is either "first in – last out" or equal running hours for each compressor.
[0] * Disabled	The fixed speed compressors will be connected in the order 1 – 2 – 3 and disconnected in the order 3 – 2 – 1. (First in – last out)

25-04 Compressor Cycling

Option:	Function:
[1] Enabled	The fixed speed compressors will be connected/disconnected to have equal running hours for each compressor.

25-05 Fixed Lead Compressor

Option:	Function:
	Fixed Lead Compressor means that the variable speed compressor is connected directly to the frequency converter and if a contactor is applied between frequency converter and compressor, this contactor will not be controlled by the frequency converter.
[0] No	The lead compressor function can alternate between the compressors controlled by the two built in relays. One compressor must be connected to the built-in RELAY 1, and the other compressor to RELAY 2. The compressor function (Cascade Compressor1 and Cascade Compressor2) will automatically be assigned to the relays (maximum two compressors can in this case be controlled from the frequency converter).
[1] * Yes	The lead compressor will be fixed (no alternation) and connected directly to the frequency converter. The 25-50 Lead Compressor Alternation is automatically set to [0] Off. Built-in relays Relay 1 and Relay 2 can be assigned to separate fixed speed compressors. In total three compressors can be controlled by the frequency converter.

25-06 Number of Compressors

Option:	Function:
	The number of compressors connected to the Cascade Controller including the variable speed compressor. If the variable speed compressor is connected directly to the frequency converter and the other fixed speed compressors (lag compressors) are controlled by the two built in relays, three compressors can be controlled. If both the variable speed and fixed speed compressors are to be controlled by built-in relays, only two compressors can be connected.
[0] * 2 compressors	If 25-05 Fixed Lead Compressor is set to [0] No: one variable speed compressor and one fixed speed compressor; both controlled by built in relay. If 25-05 Fixed Lead Compressor is set to [1] Yes: one variable speed compressor and one fixed speed compressor controlled by built-in relay
[1] 3 compressors	[1] 3 Compressors: One lead compressor, see 25-05 Fixed Lead Compressor. Two fixed speed compressors controlled by built-in relays.

6.14.2 25-2* Bandwidth Manager

Parameters for setting the bandwidth within which the pressure/temperature will be allowed to operate before staging/destaging fixed speed compressors. Also includes various timers to stabilize the control.

25-20 Staging Bandwidth [%]

Range: **Function:**

10%*	[1 - 100 %]	<p>Set the staging bandwidth (SBW) percentage to accommodate normal system pressure fluctuation. In cascade control systems, to avoid frequent switching of fixed speed compressors, the desired system pressure is typically kept within a bandwidth rather than at a constant level. The SBW is programmed as a percentage of the numerically larger value of <i>parameter 3-03 Maximum Reference</i> and <i>parameter 3-02 Minimum Reference</i>. For example, if <i>parameter 3-03 Maximum Reference</i> is 10 bar and the SBW is set at 10%, a system pressure between 4.0 and 6.0 bar is tolerated if the setpoint is 5 bar. No staging or destaging will occur within this bandwidth.</p>
------	--------------	--

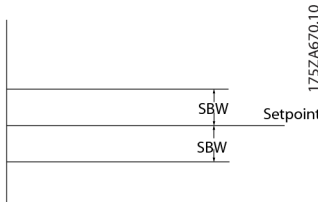

175ZA670.10

Figure 6.26 Staging Bandwidth

25-21 Override Bandwidth [%]

Range: **Function:**

		 <p style="text-align: right; font-size: x-small; margin-top: 5px;">175ZA673.10</p>
--	--	--

Figure 6.27 Override Bandwidth

Setting the OBW too close to the SBW could defeat the purpose with frequent staging at momentary pressure changes. Setting the OBW too high might lead to unacceptably high or low pressure in the system while the SBW timers are running. The value can be optimized with increased familiarity with the system. See *parameter 25-25 OBW Time*. To avoid unintended staging during the commissioning phase and fine tuning of the controller, initially leave the OBW at the factory setting of 100% (Off). When the fine tuning is completed, the OBW should be set to the desired value. An initial value of 10% is suggested.

25-21 Override Bandwidth [%]

Range: **Function:**

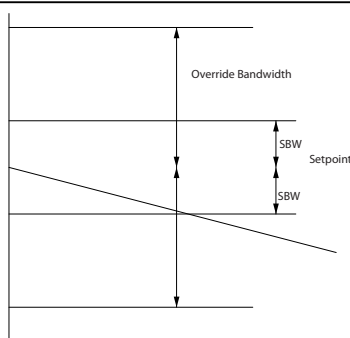
100% = Disabled*	[1 - 100%]	<p>When a large and quick change in the system demand occurs, the system pressure rapidly changes and an immediate staging or destaging of a fixed speed compressor becomes necessary to match the requirement. The override bandwidth (OBW) is programmed to override the staging/destaging timer (<i>parameter 25-23 SBW Staging Delay/parameter 25-24 SBW Destaging Delay</i>) for immediate response. The OBW must always be programmed to a higher value than the value set in <i>parameter 25-20 Staging Bandwidth (SBW)</i>. The OBW is a percentage of <i>parameter 3-03 Maximum Reference</i>.</p>
------------------	------------	---

25-22 Fixed Speed Bandwidth [%]

Range: **Function:**

10%*	[1 - 100%]	<p>When the cascade control system is running normally and the frequency converter issues a trip alarm, it is important to maintain the system head. The Cascade Controller does this by continuing to stage/destage the fixed speed compressor on and off. Due to the fact that keeping the head at the setpoint would require frequent staging and destaging when only a fixed speed compressor is running, a wider Fixed Speed Bandwidth (FSBW) is used instead of SBW. It is possible to stop the fixed speed compressors, in case of an alarm situation, by pressing the [Off] or [Hand On] or if the signal programmed for Start on digital input goes low. In case the issued alarm is a trip-lock alarm then the Cascade Controller must stop the system immediately by cutting out all the fixed speed compressors. This is basically the same as</p>
------	------------	--

25-22 Fixed Speed Bandwidth [%]

Range:	Function:
	Emergency Stop (Coast/Coast inverse Command) for the Cascade Controller.

25-23 SBW Staging Delay

Range:	Function:
60 sec.*	[0-3000 sec.]
<p>Immediate staging of a fixed speed compressor is not desirable when a momentary pressure drop in the system exceeds the Staging Bandwidth (SBW). Staging is delayed by the length of time programmed. If the pressure increases to within the SBW before the timer has elapsed, the timer is reset.</p>	
<p style="text-align: right;">175ZA672.12</p>	
<p>Figure 6.28 SBW Staging Delay</p>	

25-24 SBW Destaging Delay

Range:	Function:
60 sec.*	[0-3000 sec.]
<p>Immediate destaging of a fixed speed compressor is not desirable when a momentary pressure increase in the system that exceeds the Staging Bandwidth (SBW). Destaging is delayed by the length of time programmed. If the pressure decreases to within the SBW before the timer has elapsed, the timer is reset.</p>	
<p style="text-align: right;">175ZA671.11</p>	
<p>Figure 6.29 SBW Destaging Delay</p>	

25-25 OBW Time

Range:	Function:
60 sec.*	[0 – 300 sec.]
<p>Staging a fixed speed compressor creates a momentary pressure peak in the system, which might exceed the Override Bandwidth (OBW). It is not desirable to destage a compressor in response to a staging pressure peak. The OBW Time can be programmed to prevent staging until the system pressure has stabilized and normal control established. Set the timer to a value that allows the system to stabilize after staging. The 10 second factory setting is appropriate in most applications. In highly dynamic systems, a shorter time may be desirable.</p>	
<p style="text-align: right;">130BA370.11</p>	
<p>Figure 6.30 OBW Time</p>	

25-27 Stage Function

Option:	Function:
[0] *	Disabled
[1]	Enabled
<p>If the Stage Function is set to [0] Disabled, parameter 25-28 Stage Function Time will not be activated.</p>	

25-28 Stage Function Time

Range:	Function:
10 sec.*	[0 – 300 sec.]
<p>The Stage Function Time is programmed to avoid frequent staging of the fixed speed compressors. The Stage Function Time starts if it is [1] Enabled by parameter 25-27 Stage Function and when the variable speed compressor is running at parameter 4-13 Motor Speed High Limit [RPM] or parameter 4-14 Motor Speed High Limit [Hz] (or at parameter 4-11 Motor Speed Low Limit [RPM] or parameter 4-12 Motor Speed Low Limit [Hz] if parameter 7-30 Process PID Normal/Inverse Control is programmed to Inverse), with at least one fixed speed compressor in the stop position. When the programmed value of the timer expires, a fixed speed compressor is staged.</p>	

25-29 Destage Function		
Option:	Function:	
[0] *	Disabled	
[1]	Enabled	The Destage Function ensures that the lowest numbers of compressors are running to save energy. If the Destage Function is set to [0] Disabled, the parameter 25-30 Destage Function Time will not be activated.

25-30 Destage Function Time		
Range:	Function:	
10 sec.*	[0 – 300 sec.]	<p>The Destage Function Timer is programmable to avoid frequent staging/destaging of the fixed speed compressors. The Destage Function Time starts when the adjustable speed compressor is running at parameter 4-11 Motor Speed Low Limit [RPM] or parameter 4-12 Motor Speed Low Limit [Hz] (or at parameter 4-13 Motor Speed High Limit [RPM] or parameter 4-14 Motor Speed High Limit [Hz] if parameter 7-30 Process PID Normal/ Inverse Control is programmed to Inverse), with one or more fixed speed compressors in operation and system requirements satisfied. In this situation, the adjustable speed compressor contributes little to the system. When the programmed value of the timer expires, a stage is removed.</p> <p>Figure 6.31 Destage Function Time</p>

6.14.3 25-4* Staging Settings

Parameters determining conditions for staging/destaging the compressors.

25-40 Ramp Down Delay		
Range:	Function:	
10 sec.*	[0 – 120 sec.]	<p>When adding a fixed speed compressor controlled by a soft starter, it is possible to delay the ramp down of the lead compressor until a preset time after the start of the fixed speed compressor to eliminate pressure surges in the system.</p> <p>Only to be used if [1] Soft Starter is selected in parameter 25-02 Motor Start.</p>

25-41 Ramp Up Delay		
Range:	Function:	
10 sec.*	[0 – 120 sec.]	<p>When removing a fixed speed compressor controlled by a soft starter, it is possible to delay the ramp up of the lead compressor until a preset time after the stopping of the fixed speed compressor to eliminate pressure surges in the system.</p> <p>Only to be used if [1] Soft Starter is selected in parameter 25-02 Motor Start.</p> <p>Figure 6.32 Ramp-up Delay</p>

25-42 Staging Threshold		
Range:	Function:	
90%*	[0 – 100%]	<p>When adding a fixed speed compressor, in order to prevent an overshoot of pressure, the variable speed compressor ramps down to a lower speed. When the variable speed compressor reaches the “Staging Speed” the fixed speed compressor is staged on. The Staging Threshold is used to calculate the speed of the variable speed compressor when the “cut-in point” of the fixed speed compressor occurs. The calculation of the Staging Threshold is the ratio of parameter 4-11 Motor Speed Low Limit [RPM] or parameter 4-12 Motor Speed Low Limit [Hz] to parameter 4-13 Motor Speed High Limit [RPM] or parameter 4-14 Motor Speed High Limit [Hz] expressed in percent.</p> <p>Staging Threshold must range from</p> $\eta_{STAGE \%} = \frac{\eta_{LOW}}{\eta_{HIGH}} \times 100 \%$ <p>to 100%, where η_{LOW} is Motor Speed Low Limit and η_{HIGH} is Motor Speed High Limit.</p> <p>Figure 6.33 Staging Threshold</p>

25-43 Destaging Threshold	
Range:	Function:
50%* [0 – 100%]	<p>When removing a fixed speed compressor, in order to prevent an undershoot of pressure, the variable speed compressor ramps up to a higher speed. When the variable speed compressor reaches the “Destaging Speed” the fixed speed compressor is destaged. The Destaging Threshold is used to calculate the speed of the variable speed compressor when the destaging of the fixed speed compressor occurs. The calculation of the Destaging Threshold is the ratio of <i>parameter 4-11 Motor Speed Low Limit [RPM]</i> or <i>parameter 4-12 Motor Speed Low Limit [Hz]</i> to <i>parameter 4-13 Motor Speed High Limit [RPM]</i> or <i>parameter 4-14 Motor Speed High Limit [Hz]</i> expressed in percent.</p> <p>Destaging Threshold must range from</p> $\eta_{STAGE\%} = \frac{\eta_{LOW}}{\eta_{HIGH}} \times 100\%$ <p>to 100%, where η_{LOW} is Motor Speed Low Limit and η_{HIGH} is Motor Speed High Limit.</p> <p>Figure 6.34 Destaging Threshold</p>

25-44 Staging Speed [RPM]	
Option:	Function:
0 N/A	<p>Readout of the below calculated value for Staging Speed. When adding a fixed speed compressor, in order to prevent an overshoot of pressure, the variable speed compressor ramps down to a lower speed. When the variable speed compressor reaches the “Staging Speed” the fixed speed compressor is staged on. Staging Speed calculation is based on <i>parameter 25-42 Staging Threshold</i> and <i>parameter 4-13 Motor Speed High Limit [RPM]</i>. Staging Speed is calculated with the following formula:</p> $\eta_{STAGE} = \eta_{HIGH} \frac{\eta_{STAGE\%}}{100}$ <p>where η_{HIGH} is Motor Speed High Limit and $\eta_{STAGE100\%}$ is the value of Staging Threshold.</p>

25-45 Staging Speed [Hz]	
Option:	Function:
0 N/A	<p>Readout of the below calculated value for Staging Speed. When adding a fixed speed compressor, in order to prevent an overshoot of pressure, the variable speed compressor ramps down to a lower</p>

25-45 Staging Speed [Hz]	
Option:	Function:
	<p>speed. When the variable speed compressor reaches the “Staging Speed” the fixed speed compressor is staged on. Staging Speed calculation is based on <i>parameter 25-42 Staging Threshold</i> and <i>parameter 4-14 Motor Speed High Limit [Hz]</i>. Staging Speed is calculated with the following formula:</p> $\eta_{STAGE} = \eta_{HIGH} \frac{\eta_{STAGE\%}}{100}$ <p>where η_{HIGH} is Motor Speed High Limit and $\eta_{STAGE100\%}$ is the value of Staging Threshold.</p>

25-46 Destaging Speed [RPM]	
Option:	Function:
0 N/A	<p>Readout of the below calculated value for Destaging Speed. When removing a fixed speed compressor, in order to prevent an undershoot of pressure, the variable speed compressor ramps up to a higher speed. When the variable speed compressor reaches the “Destaging Speed” the fixed speed compressor is destaged. Destaging Speed is calculated based on <i>parameter 25-43 De-staging Threshold</i> and <i>parameter 4-13 Motor Speed High Limit [RPM]</i>. Destaging Speed is calculated with the following formula:</p> $\eta_{DESTAGE} = \eta_{HIGH} \frac{\eta_{DESTAGE\%}}{100}$ <p>where η_{HIGH} is Motor Speed High Limit and $\eta_{DESTAGE100\%}$ is the value of Destaging Threshold.</p>

25-47 Destaging Speed [Hz]	
Option:	Function:
	<p>Readout of the below calculated value for Destaging Speed. When removing a fixed speed compressor, in order to prevent an undershoot of pressure, the variable speed compressor ramps up to a higher speed. When the variable speed compressor reaches the “Destaging Speed” the fixed speed compressor is destaged. Destaging Speed is calculated based on <i>parameter 25-43 De-staging Threshold</i> and <i>parameter 4-14 Motor Speed High Limit [Hz]</i>. Destaging Speed is calculated with the following formula:</p> $\eta_{DESTAGE} = \eta_{HIGH} \frac{\eta_{DESTAGE\%}}{100}$ <p>where η_{HIGH} is Motor Speed High Limit and $\eta_{DESTAGE100\%}$ is the value of Destaging Threshold.</p>

25-47 Destaging Speed [Hz]

Option: Function:

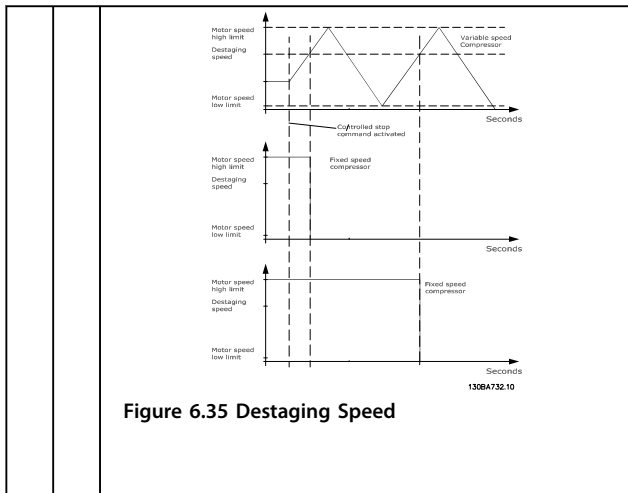

Figure 6.35 Destaging Speed

6.14.4 25-5* Alternation Settings

Parameters for defining the conditions for alternation of the variable speed compressor (lead), if selected as part of the control strategy.

25-50 Lead Compressor Alternation

Option: Function:

		Lead compressor alternation equalizes the use of compressors by periodically changing the compressor that is speed controlled. This ensures that compressors are equally used over time. Alternation equalizes the usage of compressors by always choosing the compressor with the lowest number of used hours to stage on next.
[0]	Off	No alternation of lead compressor function will take place. It is not possible to set this parameter to options other than [0] Off if parameter 25-02 Motor Start is set other than [0] Direct on Line. NOTICE! It is not possible to select other than [0] Off if parameter 25-05 Fixed Lead Compressor is set to [1] Yes.
[1]	At Staging	Alternation of the lead compressor function will take place when staging another compressor.
[2]	At Command	Alternation of the lead compressor function will take place at an external command signal or a pre-programmed event. See parameter 25-51 Alternation Event for available options.

25-50 Lead Compressor Alternation

Option: Function:

[3]	At Staging or at Command	Alternation of the variable speed (lead) compressor will take place at staging or the "At Command" signal (See above).
-----	--------------------------	--

25-51 Alternation Event

Option: Function:

		This parameter is only active if the options [2] At Command or [3] At Staging or Command have been selected in parameter 25-50 Lead Compressor Alternation. If an Alternation Event is selected, the alternation of lead compressor takes place every time the event occurs.
[0]	External *	Takes place when a signal is applied to one of the digital inputs on the terminal strip and this input has been assigned to [121] Lead Compressor Alternation in parameter group 5-1* Digital Inputs.
[1]	Alternation Time Interval	Takes place every time parameter 25-52 Alternation Time Interval expires.

25-52 Alternation Time Interval

Range: Function:

24 h*	[1 – 999 h]	If [1] Alternation Time Interval option in parameter 25-51 Alternation Event is selected, the alternation of the variable speed compressor takes place every time the Alternation Time Interval expires (can be checked out in parameter 25-53 Alternation Timer Value).
-------	-------------	--

25-53 Alternation Time Value

Option: Function:

	0 N/A	Readout parameter for the Alternation Time Interval value set in parameter 25-52 Alternation Time Interval.
--	-------	---

25-55 Alternation if Capacity < 50%

Option: Function:

[0]	Disabled	
[1]	Enabled *	If Alternation If Capacity < 50% is enabled, the compressor alternation can only occur if the capacity is equal to or below 50%. The capacity calculation is the ratio of running compressors (including the variable speed compressor) to the total number of available compressors (including variable speed compressor, but not those interlocked). $\text{Capacity} = \frac{N_{\text{Running}}}{N_{\text{Total}}} \times 100\%$ For the Basic Cascade Controller all compressors are equal size. Disabled [0]: The lead compressor alternation will take place at any compressor capacity.

25-55 Alternation if Capacity < 50%

Option: Function:

		<p><i>Enabled</i> [1]: The lead compressor function will be alternated only if the numbers of compressors running are providing less than 50% of total compressor capacity.</p> <p>Only valid if <i>parameter 25-50 Lead Compressor Alternation</i> is different from [0] Off.</p>
--	--	--

25-56 Staging Mode at Alternation

Option: Function:

		<p>This parameter is only active if the option selected in <i>parameter 25-50 Lead Compressor Alternation</i> is different from [0] Off.</p> <p>Two types of staging and destaging of compressors are possible. Slow transfer makes staging and destaging smooth. Quick Transfer makes staging and destaging as fast as possible; the variable speed compressor is just cut out (coasted).</p>
[0] *	Slow	At alternation, the variable speed compressor is ramped up to maximum speed and then ramped down to a standstill.
[1]	Quick	At alternation, the variable speed compressor is ramped up to maximum speed and then coasted to standstill.

Figure 6.36 is an example of the Slow transfer staging. The variable speed compressor (top graph) and one fixed speed compressor (bottom graph) are running before the staging command. When the [0] Slow transfer command is activated, an alternation is carried out by ramping the variable speed compressor to *parameter 4-13 Motor Speed High Limit [RPM]* or *parameter 4-14 Motor Speed High Limit [Hz]*, and then decelerated to zero speed. After a "Delay Before Starting Next Compressor" (*parameter 25-58 Run Next Compressor Delay*) the next lead compressor (middle graph) is accelerated and another original lead compressor (top graph) is added after the "Delay Before Running On Mains" (*parameter 25-59 Run on Mains Delay*) as a fixed speed compressor. The next lead compressor (middle graph) is decelerated to Motor Speed Low Limit and then allowed to vary speed to maintain system pressure.

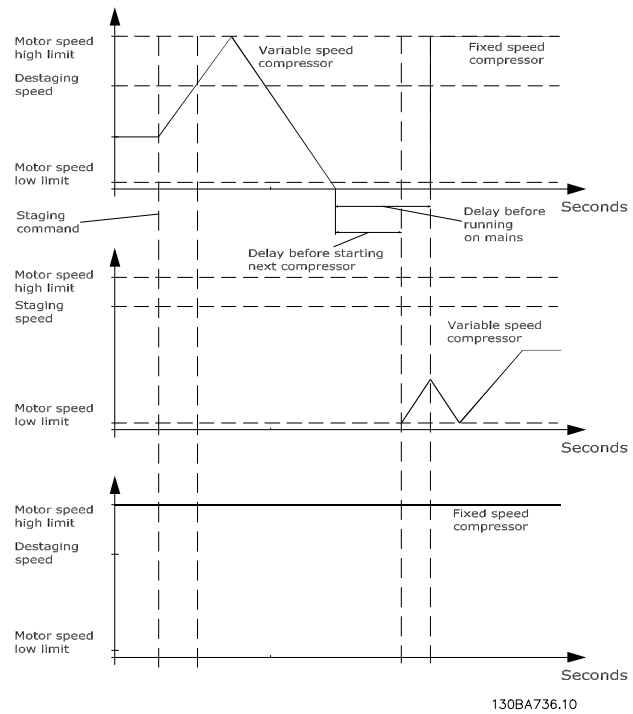

Figure 6.36 Slow Transfer Staging

25-58 Run Next Compressor Delay

Range:

Function:

0.5 sec*	[parameter 25-58 Run Next Compressor Delay – 5.0 sec]	<p>This parameter is only active if the option selected in <i>parameter 25-50 Lead Compressor Alternation</i>, is different from [0] Off.</p> <p>This parameter sets the time between stopping the old variable speed compressor and starting another compressor as a new variable speed compressor. Refer to <i>parameter 25-56 Staging Mode at Alternation</i> and <i>Figure 6.36</i> for description of staging and alternation.</p>
----------	---	---

25-59 Run on Mains Delay

Range:

Function:

0.5 sec*	[parameter 25-58 Run Next Compressor Delay – 5.0 sec]	<p>This parameter is only active if the option selected in <i>parameter 25-50 Lead Compressor Alternation</i>, is different from [0] Off.</p> <p>This parameter sets the time between stopping the old variable speed compressor and starting this compressor as a new fixed speed compressor. Refer to <i>parameter 25-56 Staging Mode at</i></p>
----------	--	--

25-59 Run on Mains Delay
Range:
Function:

		Alternation and Figure 6.36 for description of staging and alternation.
--	--	---

6.14.5 25-8* Status

Readout parameters informing about the operating status of the cascade controller and the compressors controlled.

25-80 Pack Status
Option:
Function:

	Read out of the status of the Pack Controller.
Disabled	Pack Controller is disabled (<i>parameter 25-00 Cascade Controller</i>).
Emergency	All compressors have been stopped by means of a Coast/Coast inverse or an External Interlock command applied to the frequency converter.
Off	All compressors have been stopped by means of a Stop command applied to the frequency converter.
In Open Loop	<i>parameter 1-00 Configuration Mode</i> has been set for [0] Open Loop. All fixed speed compressors are stopped. The variable speed compressor will continue to run.
Frozen	Staging/destaging of compressors has been locked and reference locked.
Jogging	All fixed speed compressors are stopped. When stopped, the variable speed compressor will run at jog speed.
Running	A Start command is applied to the frequency converter and the Pack controller is controlling the compressors.
Running FSBW	The frequency converter is tripped off and the Pack Controller is controlling the fixed speed compressors based on <i>parameter 4-14 Motor Speed High Limit [Hz]</i> .
Staging	The Pack Controller is staging fixed speed compressors.
Destaging	The Pack Controller is destaging fixed speed compressors.
Lead Not Set	No compressor available to be assigned as variable speed compressor.

25-81 Compressor Status
Option:
Function:

	Compressor Status shows the status for the number of compressors selected in <i>parameter 25-06 Number Of Pumps</i> . It is a readout of the status for each of the compressors showing a string, which consists of
--	---

25-81 Compressor Status
Option:
Function:

		compressor number and the current status of the compressor. Example: Readout is with the abbreviation like "1:D 2:O" This means that compressor 1 is running and speed controlled by the frequency converter and compressor 2 is stopped.
[X]	Disabled	The compressor is interlocked either via <i>parameter 25-90 Pump Interlock</i> , or signal on a digital input programmed for Compressor (number on compressor) Interlock in parameter group 5-1* <i>Digital Inputs</i> . Can only refer to fixed speed compressors.
[O]	Off	Stopped by the cascade controller (but not interlocked).
[D]	Running on Frequency Converter	Variable speed compressor, regardless if connected directly or controlled via relay in the frequency converter.
[R]	Running on Mains	Running on mains. Fixed speed compressor running.

25-82 Lead Compressor
Option:
Function:

	0 N/A	Readout parameter for the actual variable speed compressor in the system. It is updated to reflect the current variable speed compressor in the system when an alternation takes place. If no lead compressor is selected (Cascade Controller disabled or all compressors interlocked) the display will show NONE.
--	-------	--

25-83 Relay Status

Array [2]

	On	
	Off	Read out of the status for each of the relays assigned to control the compressors. Every element in the array represents a relay. If a relay is activated, the corresponding element is set to "On". If a relay is deactivated, the corresponding element is set to "Off".

25-84 Compressor ON Time

Array [2]

0 h*	[0 – 2147483647 h]	Readout of the value for Compressor ON Time. The Cascade Controller has set counters for the compressors and for the relays that control the compressors. Compressor ON Time monitors the "operating hours" of each compressor. The value of each Compressor ON Time counter can be reset to 0 by writing in the parameter, e.g. if the compressor is replaced in case of service.
------	--------------------	--

25-85 Relay ON Time

Array [2]

0	[0 – h* 2147483647 h]	Readout of the value for Relay ON time. The Cascade Controller has set counters for the compressors and for the relays that control the compressors. Compressor cycling is always done based on the relay counters, otherwise it would always use the new compressor if a compressor is replaced and its value in <i>parameter 25-84 Pump ON Time</i> counter is reset. In order to use <i>parameter 25-04 Pump Cycling</i> , the Cascade Controller is monitoring the Relay ON time.
---	-----------------------	---

25-86 Reset Relay Counters

Option:	Function:
[0] *	Do not reset
[1]	Do reset Resets all elements in <i>parameter 25-85 Relay ON Time</i> .

25-91 Manual Alternation

Option:	Function:
	than [0] Off is set, the alternation is carried out immediately and the compressor that is selected with Manual Alternation is the new variable speed compressor. After the alternation has been carried out, the Manual Alternation parameter is reset to [0] Off. If the parameter is set to the number which equals the actual variable speed compressor, the parameter will be reset to [0] immediately after.

6.14.6 25-9* Service

Parameters used in case of service on one or more of the compressors controlled.

25-90 Compressor Interlock

Array [2]

		In this parameter, it is possible to disable one or more of the fixed lead compressors. For example, the compressor will not be selected for staging on even if it is the next compressor in the operation sequence. It is not possible to disable the lead compressor with the Compressor Interlock command. The digital input interlocks are selected as [130 – 132] <i>Compressor 1-3 Interlock</i> in parameter group 5-1* <i>Digital Inputs</i> .
[0]	Off	The compressor is active for staging/destaging.
[1]	On	The Compressor Interlock command is given. If a compressor is running it is immediately destaged. If the compressor is not running it is not allowed to stage on.

25-91 Manual Alternation

Option:	Function:	
[0] *	0 = Off - Number of Compressors	This parameter is only active if the options <i>At Command</i> or <i>At Stating or Command</i> are selected in <i>parameter 25-50 Lead Compressor Alternation</i> . The parameter is for manually setting of what compressor to be assigned as variable speed compressor. The default value of Manual Alternation is [0] Off. If a value other

6.15 Par. Group 28 - Compressor Functions

6.15.1 28-0* Short Cycle Protection

When controlling refrigeration compressors, there is often a need for limiting the numbers of starts. One way to limit the starts is to ensure a minimum run time (time between a start and a stop) and a minimum interval between starts.

Parameter 28-02 Minimum Run Time can override any normal stop command and *parameter 28-01 Interval between Starts* can override any normal start command (Start/Jog/Freeze).

None of the two functions are active if *Hand On* or *Off* modes have been activated via the LCP. If selecting *Hand On* or *Off*, the two timers will be reset to 0, and not start counting until *Auto* is pressed and an active start command applied.

28-00 Short Cycle Protection

Option: Function:

[0]	Disabled	Timer set in <i>parameter 28-01 Interval between Starts</i> is disabled.
[1] *	Enabled	Timer set in <i>parameter 28-01 Interval between Starts</i> is enabled.

NOTICE!

This parameter can only be [1] Enabled if *parameter 25-00 Cascade Controller* is set to [0] Disabled.

28-01 Interval Between Starts

Range: Function:

300 s*	[0 - 3600 s]	Sets the time desired as minimum time between two starts. Any normal start command (Start/Jog/Freeze) is disregarded until the timer has expired.
--------	--------------	---

28-02 Minimum Run Time

Range: Function:

12 s*	[0 - par. 28-01]	Sets the time desired as minimum run time after a normal start command (Start/Jog/Freeze). Any normal stop command is disregarded until the set time has expired. The timer starts counting following a normal start command (Start/Jog/Freeze). A Coast (Inverse) or an External Interlock command override the timer.
-------	------------------	---

NOTICE!

Does not work in cascade mode.

6.15.2 28-1* Oil Return Management

Insufficient lubrication can be the result of oil depositing itself in pipes and bends. Return oil deposits to the crankcase by increasing velocity for short periods at regular time intervals or by ensuring adequate oil return when velocity is too low.

With Oil Return Management, these two oil return mechanisms can be programmed into the Compressor Drive™. With Oil Return Management enabled, the frequency converter performs oil return by boosting the compressor speed to 4200 RPM (70 Hz) for a selectable duration. Programme the duration in *parameter 28-13 Boost Duration*. The boosts are performed at fixed time intervals (programmed in *parameter 28-12 Fixed Boost Interval*) or if the compressor speed has been less than 3000 RPM (50 Hz) for too long (as programmed in *parameter 28-11 Low Speed Running Time*), whichever occurs first. Thus, the maximum time between two consecutive oil return boosts is as programmed in *parameter 28-12 Fixed Boost Interval*. A text message on the LCP indicates oil return boosts.

NOTICE!

If *parameter 4-13 Motor Speed High Limit [RPM]* or *parameter 4-14 Motor Speed High Limit [Hz]* is set to the boost speed 4200 RPM an oil boost may cause unwanted staging or destaging if parameter group 25-** *Cascade Controller* is active.

28-10 Oil Return Management

Option: Function:

[0] *	Off	No function
[1]	On	Oil return mechanism is active.

28-11 Low Speed Running Time

Range: Function:

60 min*	[1 - 1440 min]	Running at low speeds for extended periods may result in inadequate oil return to the compressor crankcase. Set this parameter to the maximum running time the compressor is allowed to run at a speed below 3000 RPM/50 Hz. An oil return boost is performed each time the compressor has been running at a low speed for this maximum time.
---------	----------------	---

28-12 Fixed Boost Interval

Range: Function:

24 h*	[1 - 168 h]	An oil return boost is performed at fixed time intervals to complement the oil return boosts triggered by inadequate flow speeds (<i>parameter 28-11 Low Speed Running Time</i>). The fixed interval boosts ensure that oil return boosts
-------	-------------	---

28-12 Fixed Boost Interval

Range:	Function:
	are performed even when no boosts have occurred due to low flow speed (parameter 28-11 Low Speed Running Time).

28-13 Boost Duration

Range:	Function:
30 s * [10 – 120 s]	This parameter controls the duration of oil return boosts.

6.15.3 28-2* Discharge Temperature Monitor

The Discharge Temperature Monitor (DTM) can be used to prevent the discharge temperature from reaching dangerous levels.

Two temperature levels of increasing severity can be programmed. These levels are referred to as "warning level" (set in par. 28-24 Warning level) and "emergency level," (set in par. 28-26 Emergency level) respectively, with increasing severity. Each level corresponds to a particular set of preventive actions.

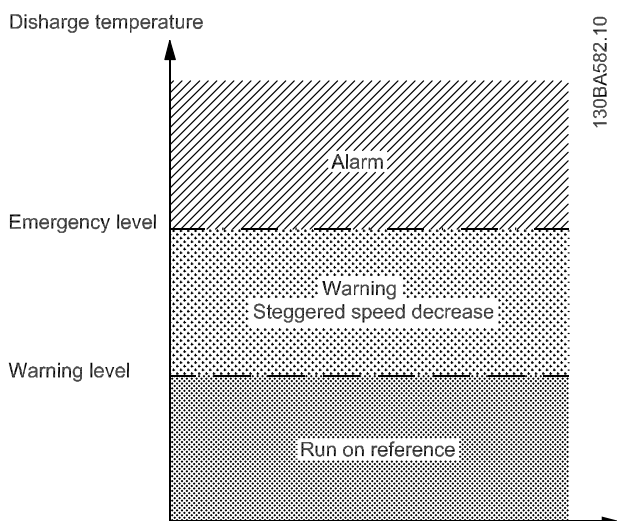

Figure 6.37

Discharge temperatures above the emergency level cause an alarm and an immediate trip to prevent damage to the compressor.

Normal operations apply for discharge temperatures below warning level. The discharge temperature is passively monitored without affecting drive operations.

Discharge temperatures in the range from warning level to emergency level trigger a warning and an action set by parameter par. 28-25 Warning Action. The action can be None or Decrease cooling. If the action is set to Decrease cooling, cooling is decreased as a preventive action in an attempt to lower the discharge temperature.

Cooling is decreased by step-wise lowering of the shaft speed until the discharge temperature either drops below warning level or exceeds emergency level. Each step represents a three-minute period during which the maximum allowed shaft speed is 10 Hz lower than the previous step. The initial step occurs when the discharge temperature exceeds the warning level and uses the current shaft speed as the basis for the 10 Hz speed reduction.

The speed steps enforce maximum shaft speeds. If the reference corresponds to a lower speed, the reference is obeyed. If it corresponds to a higher speed, the speed is limited to the maximum shaft speed for that step.

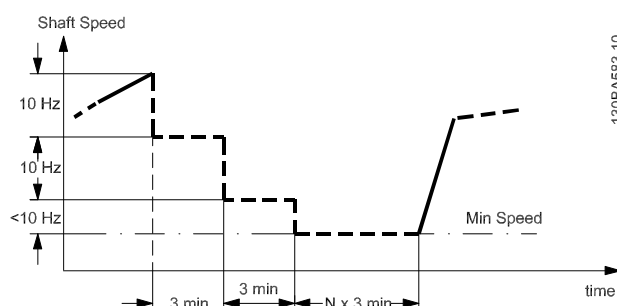

Figure 6.38

NOTICE!

If the cascade controller is active, unwanted staging or de-staging may result if the discharge temperature monitor reduces the speed to Motor Speed Low Limit, par. 4-11 or 4-12.

28-20 Temperature Source

Option: **Function:**

		Selects the input terminal to which the discharge temperature measurement device is connected.
[0]	None	No Source. The Discharge Temperature Monitor is not active.
[1]	Analog input 53	The measurement device is connected to input terminal 53. Program parameter 6-10 Terminal 53 Low Voltage to parameter 6-15 Terminal 53 High Ref./Feedb. Value to match the characteristics of the device.
[2]	Analog input 54	The measurement device is connected to input terminal 54. Program parameter 6-20 Terminal 54

28-20 Temperature Source
Option: Function:

		<i>Low Voltage to parameter 6-25 Terminal 54 High Ref./Feedb. Value to match the characteristics of the device.</i>
[3]	Bus	The actual discharge temperature should be sent via Modbus RTU or FC protocol to <i>28-27 Discharge temperature</i> . The temperature could be set via PCD write in <i>parameter 8-42 PCD Write Configuration</i> .

28-21 Temperature Unit
Option: Function:

		Selects the unit of the discharge temperature.
[60] *	°C	
[160]	°F	

28-24 Warning Level
Range: Function:

130 *	[10– <i>parameter 28-26 Emergency Level</i>]	Selects the temperature at which a warning shall be issued. The action selected in <i>parameter 28-25 Warning Action</i> becomes active at this temperature. Enter the temperature measured in the unit selected in <i>parameter 28-21 Temperature Unit</i> .
-------	--	---

28-25 Warning Action
Option: Function:

		Selects the action to be taken by the frequency converter for discharge temperatures above the value programmed in <i>parameter 28-21 Temperature Unit</i> but below the value programmed in <i>parameter 28-26 Emergency Level</i> .
[0]	None	No action. Only a warning is issued.
[1] *	Decrease cooling	A warning is issued and the motor speed is lowered in steps of 10 Hz every 3 minutes until the temperature either drops below the level programmed in <i>parameter 28-24 Warning Level</i> or exceeds the level programmed in <i>parameter 28-26 Emergency Level</i> .

28-26 Emergency Level
Range: Function:

145*	[<i>parameter 28-24 Warning Level-300</i>]	Selects the temperature at which an alarm shall be issued. Enter the temperature in the unit programmed in <i>parameter 28-21 Temperature Unit</i> .
------	--	--

28-27 Discharge Temperature
Range: Function:

0*	[-2147483648 – 2147483648]	Returns the actual value of the discharge temperature.
----	-------------------------------	--

6.15.4 28-3* Crankcase Heating

A DC-hold Current through the motor windings can be used as an alternative to an external crankcase heater to keep the compressor warm when stopped.

The efficiency of the Crankcase Heating depends upon the physical placing of the actual motor in the compressor.

If the Crankcase Heating is used together with Anti-Reverse Protection, the frequency converter first brakes for the set duration followed by the heating current.

28-30 Crankcase Heating Control
Option: Function:

		Activate the DC-hold current when the motor is stopped. The current level is defined in <i>parameter 28-31 Heating DC Current</i> .
[0] *	Disabled	
[1]	Enabled	

28-31 Heating DC Current
Range: Function:

20% *	[0 – 25%]	Set the DC-hold current as percentage of the rated motor current in <i>parameter 1-24 Motor Current</i> .
-------	-----------	---

28-32 Crankcase Heating Delayed
Range: Function:

5 s *	[5-65534 s]	This time defines the delay after a stop and until Crank Case Heating is applied to the compressor.
-------	-------------	---

6.15.5 28-4* Anti-reverse Protection

A compressor may have a preferred rotation direction and the instructions for cabling should always be followed, but the consequences of a reverse rotation are normally not fatal. Set up parameter group *28-4* Anti-reverse Protection* to prevent reverse rotation at stop by injecting a DC-brake current into the motor a few seconds after stop followed by the eventual coast of the motor when the discharge valve has closed.

NOTICE!

The DC-brake Function is not operational before any Start Function has completed. In case of an emergency stop before the starting sequence has completed then the compressor may rotate reverse for a short moment after stop. Under normal circumstances, the Short Cycle Protection feature ensures the correct sequence.

28-40 Reverse Protection Control

Option:	Function:
[0] * Disabled	Activate a DC-brake current when the motor is stopped. The current level is defined in parameter 28-41 DC Brake Current. Not recommended for Piston compressors.
[1] Enabled	

28-41 DC Brake Current

Range:	Function:
90% * [0 – max motor current]	Set the DC-brake current as percentage of the rated motor current in parameter 1-24 Motor Current.

28-42 DC Braking Time

Range:	Function:
2.0 s* [0 – 60.0 s]	Set the duration of the DC-brake current.

28-43 DC Brake Cut-in Speed [RPM]

Range:	Function:
700 RPM '0' = Off* [0 – max motor speed]	Set the speed where the DC-brake Current should cut in. The speed must be higher than 0 RPM for the DC-brake to activate before the motor is coasted at 0 RPM to prevent a reverse rotation.

6.15.6 28-5* Load Profile

The Load Profiler is used to get a graphical presentation of the load pattern a cooling system has been subjected to over the last 6 months. The system load is assumed to be proportional to the compressor speed, and the Load Profiler measures the load as the running hours spent operating within certain speed intervals.

The speed intervals are calculated based on parameter 4-11 Motor Speed Low Limit [RPM] (parameter 4-13 Motor Speed High Limit [RPM]) and parameter 4-13 Motor Speed High Limit [RPM] (parameter 4-14 Motor Speed High Limit [Hz]) to match 0%, 25%, 50%, 75% and 100% loads as good as possible. The

speed intervals are denoted "Off", "Low", "Med.", "High" and "Full" and are calculated in the following manner:

$$\Delta = \text{Motor Speed High Limit} - \text{Motor Speed Low Limit}$$

Off: Speed = 0

$$\text{Low: } \text{Motor Speed Low Limit} \leq \text{Speed} < \text{Motor Speed Low Limit} + \Delta/6$$

$$\text{Med. } \text{Motor Speed Low Limit} + \Delta/6 \leq \text{Speed} < \text{Motor Speed Low Limit} + \Delta/2$$

$$\text{High: } \text{Motor Speed Low Limit} + \Delta/2 \leq \text{Speed} < \text{Motor Speed Low Limit} + 5 \times \Delta/6$$

$$\text{Full: } \text{Motor Speed Low Limit} + 5 \times \Delta/6 \leq \text{Speed} \leq \text{Motor Speed High Limit}$$

For example, if 4-11 Motor Speed High Limit is 5400 RPM and Motor Speed Low Limit is 1800 RPM the four calculated intervals become

Low: 1800 RPM ≤ speed < 2350 RPM

Med: 2350 RPM ≤ speed < 3450 RPM

High: 3450 RPM ≤ speed < 4550 RPM

Full: 4550 RPM ≤ speed ≤ 5400 RPM

The profile is presented on the LCP as a histogram. In each speed interval, the indicated running time is accurate to within 1 hour.

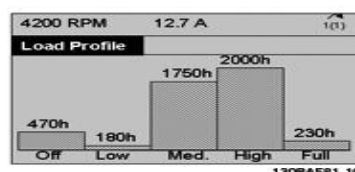

Figure 6.39 Load Profile

If [Off] is pressed on the LCP, the Load Profile is not updated.

28-50 Reset Load Profile

Option:	Function:
[0] * Do not reset	No function
[1] Reset	Clears the measured running time in all five speed intervals.

28-74 Night Speed Drop [RPM]
Range: Function:

	□	The value in this parameter decrements the value in <i>parameter 4-13 Motor Speed High Limit [RPM]</i> which becomes active when night mode is activated.
--	---	---

6.16 Parameter Lists

Changes during operation

"TRUE" means that the parameter can be changed while the frequency converter is in operation. "FALSE" means that the frequency converter must be stopped before a change can be made.

4-Set-up

'All set-ups': the parameter can be set individually in each of the four set-ups, i. e. one single parameter can have four different data values.

'1 set-up': data value will be the same in all set-ups.

Data type	Description	Type
2	Integer 8	Int8
3	Integer 16	Int16
4	Integer 32	Int32
5	Unsigned 8	UInt8
6	Unsigned 16	UInt16
7	Unsigned 32	UInt32
9	Visible String	VisStr
33	Normalized value 2 bytes	N2
35	Bit sequence of 16 Boolean variables	V2
54	Time difference w/o date	TimD

Table 6.12

6.16.1 Conversion

The various attributes of each parameter are displayed in Factory Setting. Parameter values are transferred as whole numbers only. Conversion factors are therefore used to transfer decimals.

Parameter 4-12 Motor Speed Low Limit [Hz] has a conversion factor of 0.1. To preset the minimum frequency to 10 Hz, transfer the value 100. A conversion factor of 0.1 means that the value transferred is multiplied by 0.1. The value 100 is therefore read as 10.0.

Examples:

0s ⇒ conversion index 0

0.00s ⇒ conversion index -2

0ms ⇒ conversion index -3

0.00ms ⇒ conversion index -5

Conversion index	Conversion factor
100	
75	
74	
67	
6	1000000
5	100000
4	10000
3	1000
2	100
1	10
0	1
-1	0.1
-2	0.01
-3	0.001
-4	0.0001
-5	0.00001
-6	0.000001
-7	0.0000001

Table 6.13 Conversion Table

6.16.2 0-** Operation/Display

Par. No. #	Parameter description	Default value	4-set-up	Change during operation	Conversion index	Type
0-0* Basic Settings						
0-01	Language	[0] English	1 set-up	TRUE	-	UInt8
0-02	Motor Speed Unit	[1] Hz	2 set-ups	FALSE	-	UInt8
0-03	Regional Settings	ExpressionLimit	2 set-ups	FALSE	-	UInt8
0-04	Operating State at Power-up	[0] Resume	All set-ups	TRUE	-	UInt8
0-05	Local Mode Unit	[0] As Motor Speed Unit	2 set-ups	FALSE	-	UInt8
0-1* Set-up Operations						
0-10	Active Set-up	[1] Set-up 1	1 set-up	TRUE	-	UInt8
0-11	Programming Set-up	[9] Active Set-up	All set-ups	TRUE	-	UInt8
0-12	This Set-up Linked to	[0] Not linked	All set-ups	FALSE	-	UInt8
0-13	Readout: Linked Set-ups	0 N/A	All set-ups	FALSE	0	UInt16
0-14	Readout: Prog. Set-ups / Channel	0 N/A	All set-ups	TRUE	0	Int32
0-2* LCP Display						
0-20	Display Line 1.1 Small	ExpressionLimit	All set-ups	TRUE	-	UInt16
0-21	Display Line 1.2 Small	ExpressionLimit	All set-ups	TRUE	-	UInt16
0-22	Display Line 1.3 Small	ExpressionLimit	All set-ups	TRUE	-	UInt16
0-23	Display Line 2 Large	ExpressionLimit	All set-ups	TRUE	-	UInt16
0-24	Display Line 3 Large	ExpressionLimit	All set-ups	TRUE	-	UInt16
0-25	My Personal Menu	ExpressionLimit	1 set-up	TRUE	0	UInt16
0-3* LCP Custom Readout						
0-30	Custom Readout Unit	[1] %	All set-ups	TRUE	-	UInt8
0-31	Custom Readout Min Value	ExpressionLimit	All set-ups	TRUE	-2	Int32
0-32	Custom Readout Max Value	100 CustomReadoutUnit	All set-ups	TRUE	-2	Int32
0-37	Display Text 1	0 N/A	1 set-up	TRUE	0	VisStr[25]
0-38	Display Text 2	0 N/A	1 set-up	TRUE	0	VisStr[25]
0-39	Display Text 3	0 N/A	1 set-up	TRUE	0	VisStr[25]
0-4* LCP Keypad						
0-40	[Hand on] Key on LCP	[1] Enabled	All set-ups	TRUE	-	UInt8
0-41	[Off] Key on LCP	[1] Enabled	All set-ups	TRUE	-	UInt8
0-42	[Auto on] Key on LCP	[1] Enabled	All set-ups	TRUE	-	UInt8
0-43	[Reset] Key on LCP	[1] Enabled	All set-ups	TRUE	-	UInt8
0-5* Copy/Save						
0-50	LCP Copy	[0] No copy	All set-ups	FALSE	-	UInt8
0-51	Set-up Copy	[0] No copy	All set-ups	FALSE	-	UInt8
0-6* Password						
0-60	Main Menu Password	100 N/A	1 set-up	TRUE	0	Int16
0-61	Access to Main Menu w/o Password	[0] Full access	1 set-up	TRUE	-	UInt8
0-65	Personal Menu Password	200 N/A	1 set-up	TRUE	0	Int16
0-66	Access to Personal Menu w/o Password	[0] Full access	1 set-up	TRUE	-	UInt8
0-67	Bus Password Access	0 N/A	All set-ups	TRUE	0	UInt16
0-7* Clock Settings						
0-70	Set Date and Time	ExpressionLimit	All set-ups	TRUE	0	TimeOfDay
0-71	Date Format	ExpressionLimit	1 set-up	TRUE	-	UInt8
0-72	Time Format	ExpressionLimit	1 set-up	TRUE	-	UInt8
0-74	DST/Summertime	[0] Off	1 set-up	TRUE	-	UInt8
0-76	DST/Summertime Start	ExpressionLimit	1 set-up	TRUE	0	TimeOfDay

Parameter Descriptions
Operating Instructions

Par. No. #	Parameter description	Default value	4-set-up	Change during operation	Conversion index	Type
0-77	DST/Summertime End	ExpressionLimit	1 set-up	TRUE	0	TimeOfDay
0-79	Clock Fault	[0] Disabled	1 set-up	TRUE	-	UInt8
0-81	Working Days	ExpressionLimit	1 set-up	TRUE	-	UInt8
0-82	Additional Working Days	ExpressionLimit	1 set-up	TRUE	0	TimeOfDay
0-83	Additional Non-Working Days	ExpressionLimit	1 set-up	TRUE	0	TimeOfDay
0-89	Date and Time Readout	0 N/A	All set-ups	TRUE	0	VisStr[25]

6.16.3 1-** Load/Motor

Par. No. #	Parameter description	Default value	4-set-up	Change during operation	Conversion index	Type
1-0* General Settings						
1-00	Configuration Mode	ExpressionLimit	All set-ups	TRUE	-	Uint8
1-03	Torque Characteristics	[0] Compressor CT	All set-ups	TRUE	-	Uint8
1-1* Motor Selection						
1-10	Motor Construction	[0] Asynchron	All set-ups	FALSE	-	Uint8
1-1* VVC+ PM						
1-14	Damping Gain	120 %	All set-ups	TRUE	0	Int16
1-15	Low Speed Filter Time Const.	ExpressionLimit	All set-ups	TRUE	-2	Uint16
1-16	High Speed Filter Time Const.	ExpressionLimit	All set-ups	TRUE	-2	Uint16
1-17	Voltage filter time const.	ExpressionLimit	All set-ups	TRUE	-3	Uint16
1-2* Motor Data						
1-20	Motor Power [kW]	ExpressionLimit	All set-ups	FALSE	1	Uint32
1-21	Motor Power [HP]	ExpressionLimit	All set-ups	FALSE	-2	Uint32
1-22	Motor Voltage	ExpressionLimit	All set-ups	FALSE	0	Uint16
1-23	Motor Frequency	ExpressionLimit	All set-ups	FALSE	0	Uint16
1-24	Motor Current	ExpressionLimit	All set-ups	FALSE	-2	Uint32
1-25	Motor Nominal Speed	ExpressionLimit	All set-ups	FALSE	67	Uint16
1-26	Motor Cont. Rated Torque	ExpressionLimit	All set-ups	FALSE	-1	Uint32
1-28	Motor Rotation Check	[0] Off	All set-ups	FALSE	-	Uint8
1-29	Automatic Motor Adaptation (AMA)	[0] Off	All set-ups	FALSE	-	Uint8
1-3* Adv. Motor Data						
1-30	Stator Resistance (Rs)	ExpressionLimit	All set-ups	FALSE	-4	Uint32
1-31	Rotor Resistance (Rr)	ExpressionLimit	All set-ups	FALSE	-4	Uint32
1-35	Main Reactance (Xh)	ExpressionLimit	All set-ups	FALSE	-4	Uint32
1-36	Iron Loss Resistance (Rfe)	ExpressionLimit	All set-ups	FALSE	-3	Uint32
1-37	d-axis Inductance (Ld)	ExpressionLimit	All set-ups	FALSE	-6	Int32
1-39	Motor Poles	ExpressionLimit	All set-ups	FALSE	0	Uint8
1-40	Back EMF at 1000 RPM	ExpressionLimit	All set-ups	FALSE	0	Uint16
1-5* Load Indep. Setting						
1-50	Motor Magnetization at Zero Speed	100 %	All set-ups	TRUE	0	Uint16
1-51	Min Speed Normal Magnetizing [RPM]	ExpressionLimit	All set-ups	TRUE	67	Uint16
1-52	Min Speed Normal Magnetizing [Hz]	ExpressionLimit	All set-ups	TRUE	-1	Uint16
1-58	Flystart Test Pulses Current	ExpressionLimit	All set-ups	FALSE	0	Uint16
1-59	Flystart Test Pulses Frequency	ExpressionLimit	All set-ups	FALSE	0	Uint16
1-6* Load Depen. Setting						
1-60	Low Speed Load Compensation	100 %	All set-ups	TRUE	0	Int16
1-61	High Speed Load Compensation	100 %	All set-ups	TRUE	0	Int16
1-62	Slip Compensation	0 %	All set-ups	TRUE	0	Int16
1-63	Slip Compensation Time Constant	ExpressionLimit	All set-ups	TRUE	-2	Uint16
1-64	Resonance Dampening	100 %	All set-ups	TRUE	0	Uint16
1-65	Resonance Dampening Time Constant	5 ms	All set-ups	TRUE	-3	Uint8
1-66	Min. Current at Low Speed	ExpressionLimit	All set-ups	TRUE	0	Uint8
1-7* Start Adjustments						
1-70	PM Start Mode	[1] Parking	All set-ups	TRUE	-	Uint8
1-71	Start Delay	00 s	All set-ups	TRUE	-1	Uint16
1-72	Start Function	ExpressionLimit	All set-ups	TRUE	-	Uint8

Par. No. #	Parameter description	Default value	4-set-up	Change during operation	Conversion index	Type
1-73	Flying Start	ExpressionLimit	All set-ups	FALSE	-	Uint8
1-74	Start Speed [RPM]	ExpressionLimit	All set-ups	TRUE	67	Uint16
1-75	Start Speed [Hz]	ExpressionLimit	All set-ups	TRUE	-1	Uint16
1-76	Start Current	0 A	All set-ups	TRUE	-2	Uint32
1-77	Compressor Start Max Speed [RPM]	ExpressionLimit	All set-ups	TRUE	67	Uint16
1-78	Compressor Start Max Speed [Hz]	ExpressionLimit	All set-ups	TRUE	-1	Uint16
1-79	Compressor Start Max Time to Trip	5 s	All set-ups	TRUE	-1	Uint8
1-8* Stop Adjustments						
1-80	Function at Stop	[0] Coast	All set-ups	TRUE	-	Uint8
1-81	Min Speed for Function at Stop [RPM]	ExpressionLimit	All set-ups	TRUE	67	Uint16
1-82	Min Speed for Function at Stop [Hz]	ExpressionLimit	All set-ups	TRUE	-1	Uint16
1-86	Compressor Min. Speed for Trip [RPM]	ExpressionLimit	All set-ups	TRUE	67	Uint16
1-87	Compressor Min. Speed for Trip [Hz]	ExpressionLimit	All set-ups	TRUE	-1	Uint16
1-9* Motor Temperature						
1-90	Motor Thermal Protection	ExpressionLimit	All set-ups	TRUE	-	Uint8
1-91	Motor External Fan	[0] None	All set-ups	TRUE	-	Uint8
1-93	Thermistor Source	[0] None	All set-ups	TRUE	-	Uint8

6.16.4 3-** Reference/Ramps

Par. No. #	Parameter description	Default value	4-set-up	Change during operation	Conversion index	Type
3-0* Reference Limits						
3-02	Minimum Reference	ExpressionLimit	All set-ups	TRUE	-3	Int32
3-03	Maximum Reference	ExpressionLimit	All set-ups	TRUE	-3	Int32
3-04	Reference Function	[0] Sum	All set-ups	TRUE	-	Uint8
3-1* References						
3-10	Preset Reference	0 %	All set-ups	TRUE	-2	Int16
3-11	Jog Speed [Hz]	ExpressionLimit	All set-ups	TRUE	-1	Uint16
3-13	Reference Site	[0] Linked to Hand / Auto	All set-ups	TRUE	-	Uint8
3-14	Preset Relative Reference	0 %	All set-ups	TRUE	-2	Int32
3-15	Reference 1 Source	[1] Analog Input 53	All set-ups	TRUE	-	Uint8
3-16	Reference 2 Source	[20] Digital pot.meter	All set-ups	TRUE	-	Uint8
3-17	Reference 3 Source	[0] No function	All set-ups	TRUE	-	Uint8
3-19	Jog Speed [RPM]	ExpressionLimit	All set-ups	TRUE	67	Uint16
3-4* Ramp 1						
3-41	Ramp 1 Ramp Up Time	ExpressionLimit	All set-ups	TRUE	-2	Uint32
3-42	Ramp 1 Ramp Down Time	ExpressionLimit	All set-ups	TRUE	-2	Uint32
3-5* Ramp 2						
3-51	Ramp 2 Ramp Up Time	ExpressionLimit	All set-ups	TRUE	-2	Uint32
3-52	Ramp 2 Ramp Down Time	ExpressionLimit	All set-ups	TRUE	-2	Uint32
3-8* Other Ramps						
3-80	Jog Ramp Time	ExpressionLimit	All set-ups	TRUE	-2	Uint32
3-81	Quick Stop Ramp Time	ExpressionLimit	2 set-ups	TRUE	-2	Uint32
3-82	Starting Ramp Up Time	ExpressionLimit	2 set-ups	TRUE	-2	Uint32
3-9* Digital Pot.Meter						
3-90	Step Size	0.10 %	All set-ups	TRUE	-2	Uint16
3-91	Ramp Time	1 s	All set-ups	TRUE	-2	Uint32
3-92	Power Restore	[0] Off	All set-ups	TRUE	-	Uint8
3-93	Maximum Limit	100 %	All set-ups	TRUE	0	Int16
3-94	Minimum Limit	0 %	All set-ups	TRUE	0	Int16
3-95	Ramp Delay	1 N/A	All set-ups	TRUE	-3	TimD

6.16.5 4-** Limits/Warnings

Par. No. #	Parameter description	Default value	4-set-up	Change during operation	Conversion index	Type
4-1* Motor Limits						
4-10	Motor Speed Direction	[0] Clockwise	All set-ups	FALSE	-	Uint8
4-11	Motor Speed Low Limit [RPM]	ExpressionLimit	All set-ups	TRUE	67	Uint16
4-12	Motor Speed Low Limit [Hz]	ExpressionLimit	All set-ups	TRUE	-1	Uint16
4-13	Motor Speed High Limit [RPM]	ExpressionLimit	All set-ups	TRUE	67	Uint16
4-14	Motor Speed High Limit [Hz]	ExpressionLimit	All set-ups	TRUE	-1	Uint16
4-16	Torque Limit Motor Mode	110 %	All set-ups	TRUE	-1	Uint16
4-17	Torque Limit Generator Mode	100 %	All set-ups	TRUE	-1	Uint16
4-18	Current Limit	ExpressionLimit	All set-ups	TRUE	-1	Uint32
4-19	Max Output Frequency	ExpressionLimit	All set-ups	FALSE	-1	Uint16
4-5* Adj. Warnings						
4-50	Warning Current Low	0 A	All set-ups	TRUE	-2	Uint32
4-51	Warning Current High	I _{maxVLT} (P1637)	All set-ups	TRUE	-2	Uint32
4-52	Warning Speed Low	0 RPM	All set-ups	TRUE	67	Uint16
4-53	Warning Speed High	outputSpeedHighLimit (P413)	All set-ups	TRUE	67	Uint16
4-54	Warning Reference Low	-999999 N/A	All set-ups	TRUE	-3	Int32
4-55	Warning Reference High	999999 N/A	All set-ups	TRUE	-3	Int32
4-56	Warning Feedback Low	-999999 ReferenceFeed-backUnit	All set-ups	TRUE	-3	Int32
4-57	Warning Feedback High	999999 ReferenceFeed-backUnit	All set-ups	TRUE	-3	Int32
4-58	Missing Motor Phase Function	ExpressionLimit	All set-ups	TRUE	-	Uint8
4-6* Speed Bypass						
4-60	Bypass Speed From [RPM]	ExpressionLimit	All set-ups	TRUE	67	Uint16
4-61	Bypass Speed From [Hz]	ExpressionLimit	All set-ups	TRUE	-1	Uint16
4-62	Bypass Speed To [RPM]	ExpressionLimit	All set-ups	TRUE	67	Uint16
4-63	Bypass Speed To [Hz]	ExpressionLimit	All set-ups	TRUE	-1	Uint16
4-64	Semi-Auto Bypass Set-up	[0] Off	All set-ups	FALSE	-	Uint8

6.16.6 5-** Digital In/Out

Par. No. #	Parameter description	Default value	4-set-up	Change during operation	Conversion index	Type
5-0* Digital I/O mode						
5-00	Digital I/O Mode	[0] PNP - Active at 24V	All set-ups	FALSE	-	Uin8
5-01	Terminal 27 Mode	[0] Input	All set-ups	TRUE	-	Uin8
5-02	Terminal 29 Mode	[0] Input	All set-ups	TRUE	-	Uin8
5-1* Digital Inputs						
5-10	Terminal 18 Digital Input	ExpressionLimit	All set-ups	TRUE	-	Uin8
5-11	Terminal 19 Digital Input	ExpressionLimit	All set-ups	TRUE	-	Uin8
5-12	Terminal 27 Digital Input	ExpressionLimit	All set-ups	TRUE	-	Uin8
5-13	Terminal 29 Digital Input	ExpressionLimit	All set-ups	TRUE	-	Uin8
5-14	Terminal 32 Digital Input	ExpressionLimit	All set-ups	TRUE	-	Uin8
5-15	Terminal 33 Digital Input	ExpressionLimit	All set-ups	TRUE	-	Uin8
5-16	Terminal X30/2 Digital Input	ExpressionLimit	All set-ups	TRUE	-	Uin8
5-17	Terminal X30/3 Digital Input	ExpressionLimit	All set-ups	TRUE	-	Uin8
5-18	Terminal X30/4 Digital Input	ExpressionLimit	All set-ups	TRUE	-	Uin8
5-19	Terminal 37 Safe Stop	[1] Safe Stop Alarm	All set-ups	TRUE	-	Uin8
5-3* Digital Outputs						
5-30	Terminal 27 Digital Output	[0] No operation	All set-ups	TRUE	-	Uin8
5-31	Terminal 29 Digital Output	[0] No operation	All set-ups	TRUE	-	Uin8
5-32	Term X30/6 Digi Out (MCB 101)	[0] No operation	All set-ups	TRUE	-	Uin8
5-33	Term X30/7 Digi Out (MCB 101)	[0] No operation	All set-ups	TRUE	-	Uin8
5-4* Relays						
5-40	Function Relay	ExpressionLimit	All set-ups	TRUE	-	Uin8
5-41	On Delay, Relay	0.01 s	All set-ups	TRUE	-2	Uin16
5-42	Off Delay, Relay	0.01 s	All set-ups	TRUE	-2	Uin16
5-5* Pulse Input						
5-50	Term. 29 Low Frequency	100 Hz	All set-ups	TRUE	0	Uin32
5-51	Term. 29 High Frequency	100 Hz	All set-ups	TRUE	0	Uin32
5-52	Term. 29 Low Ref./Feedb. Value	0 N/A	All set-ups	TRUE	-3	Int32
5-53	Term. 29 High Ref./Feedb. Value	100 N/A	All set-ups	TRUE	-3	Int32
5-54	Pulse Filter Time Constant #29	100 ms	All set-ups	FALSE	-3	Uin16
5-55	Term. 33 Low Frequency	100 Hz	All set-ups	TRUE	0	Uin32
5-56	Term. 33 High Frequency	100 Hz	All set-ups	TRUE	0	Uin32
5-57	Term. 33 Low Ref./Feedb. Value	0 N/A	All set-ups	TRUE	-3	Int32
5-58	Term. 33 High Ref./Feedb. Value	100 N/A	All set-ups	TRUE	-3	Int32
5-59	Pulse Filter Time Constant #33	100 ms	All set-ups	FALSE	-3	Uin16
5-6* Pulse Output						
5-60	Terminal 27 Pulse Output Variable	[0] No operation	All set-ups	TRUE	-	Uin8
5-62	Pulse Output Max Freq #27	5000 Hz	All set-ups	TRUE	0	Uin32
5-63	Terminal 29 Pulse Output Variable	[0] No operation	All set-ups	TRUE	-	Uin8
5-65	Pulse Output Max Freq #29	5000 Hz	All set-ups	TRUE	0	Uin32
5-66	Terminal X30/6 Pulse Output Variable	[0] No operation	All set-ups	TRUE	-	Uin8
5-68	Pulse Output Max Freq #X30/6	5000 Hz	All set-ups	TRUE	0	Uin32
5-9* Bus Controlled						
5-90	Digital & Relay Bus Control	0 N/A	All set-ups	TRUE	0	Uin32
5-93	Pulse Out #27 Bus Control	0 %	All set-ups	TRUE	-2	N2
5-94	Pulse Out #27 Timeout Preset	0 %	1 set-up	TRUE	-2	Uin16

Par. No. #	Parameter description	Default value	4-set-up	Change during operation	Conversion index	Type
5-95	Pulse Out #29 Bus Control	0 %	All set-ups	TRUE	-2	N2
5-96	Pulse Out #29 Timeout Preset	0 %	1 set-up	TRUE	-2	Uint16
5-97	Pulse Out #X30/6 Bus Control	0 %	All set-ups	TRUE	-2	N2
5-98	Pulse Out #X30/6 Timeout Preset	0 %	1 set-up	TRUE	-2	Uint16

6.16.7 6-** Analog In/Out

Par. No. #	Parameter description	Default value	4-set-up	Change during operation	Conversion index	Type
6-0* Analog I/O Mode						
6-00	Live Zero Timeout Time	10 s	All set-ups	TRUE	0	Uint8
6-01	Live Zero Timeout Function	[0] Off	All set-ups	TRUE	-	Uint8
6-02	Fire Mode Live Zero Timeout Function	[0] Off	All set-ups	TRUE	-	Uint8
6-1* Analog Input 53						
6-10	Terminal 53 Low Voltage	0.07 V	All set-ups	TRUE	-2	Int16
6-11	Terminal 53 High Voltage	10 V	All set-ups	TRUE	-2	Int16
6-12	Terminal 53 Low Current	4 mA	All set-ups	TRUE	-5	Int16
6-13	Terminal 53 High Current	20 mA	All set-ups	TRUE	-5	Int16
6-14	Terminal 53 Low Ref./Feedb. Value	0 N/A	All set-ups	TRUE	-3	Int32
6-15	Terminal 53 High Ref./Feedb. Value	ExpressionLimit	All set-ups	TRUE	-3	Int32
6-16	Terminal 53 Filter Time Constant	0.001 s	All set-ups	TRUE	-3	Uint16
6-17	Terminal 53 Live Zero	[1] Enabled	All set-ups	TRUE	-	Uint8
6-2* Analog Input 54						
6-20	Terminal 54 Low Voltage	0.07 V	All set-ups	TRUE	-2	Int16
6-21	Terminal 54 High Voltage	10 V	All set-ups	TRUE	-2	Int16
6-22	Terminal 54 Low Current	4 mA	All set-ups	TRUE	-5	Int16
6-23	Terminal 54 High Current	20 mA	All set-ups	TRUE	-5	Int16
6-24	Terminal 54 Low Ref./Feedb. Value	-1 N/A	All set-ups	TRUE	-3	Int32
6-25	Terminal 54 High Ref./Feedb. Value	ExpressionLimit	All set-ups	TRUE	-3	Int32
6-26	Terminal 54 Filter Time Constant	0.001 s	All set-ups	TRUE	-3	Uint16
6-27	Terminal 54 Live Zero	[1] Enabled	All set-ups	TRUE	-	Uint8
6-3* Analog Input X30/11						
6-30	Terminal X30/11 Low Voltage	0.07 V	All set-ups	TRUE	-2	Int16
6-31	Terminal X30/11 High Voltage	10 V	All set-ups	TRUE	-2	Int16
6-34	Term. X30/11 Low Ref./Feedb. Value	0 N/A	All set-ups	TRUE	-3	Int32
6-35	Term. X30/11 High Ref./Feedb. Value	100 N/A	All set-ups	TRUE	-3	Int32
6-36	Term. X30/11 Filter Time Constant	0.001 s	All set-ups	TRUE	-3	Uint16
6-37	Term. X30/11 Live Zero	[1] Enabled	All set-ups	TRUE	-	Uint8
6-4* Analog Input X30/12						
6-40	Terminal X30/12 Low Voltage	0.07 V	All set-ups	TRUE	-2	Int16
6-41	Terminal X30/12 High Voltage	10 V	All set-ups	TRUE	-2	Int16
6-44	Term. X30/12 Low Ref./Feedb. Value	0 N/A	All set-ups	TRUE	-3	Int32
6-45	Term. X30/12 High Ref./Feedb. Value	100 N/A	All set-ups	TRUE	-3	Int32
6-46	Term. X30/12 Filter Time Constant	0.001 s	All set-ups	TRUE	-3	Uint16
6-47	Term. X30/12 Live Zero	[1] Enabled	All set-ups	TRUE	-	Uint8
6-5* Analog Output 42						
6-50	Terminal 42 Output	[100] Output frequency	All set-ups	TRUE	-	Uint8
6-51	Terminal 42 Output Min Scale	0 %	All set-ups	TRUE	-2	Int16
6-52	Terminal 42 Output Max Scale	100 %	All set-ups	TRUE	-2	Int16
6-53	Terminal 42 Output Bus Control	0 %	All set-ups	TRUE	-2	N2
6-54	Terminal 42 Output Timeout Preset	0 %	1 set-up	TRUE	-2	Uint16
6-6* Analog Output X30/8						
6-60	Terminal X30/8 Output	[0] No operation	All set-ups	TRUE	-	Uint8
6-61	Terminal X30/8 Min. Scale	0 %	All set-ups	TRUE	-2	Int16
6-62	Terminal X30/8 Max. Scale	100 %	All set-ups	TRUE	-2	Int16

Par. No. #	Parameter description	Default value	4-set-up	Change during operation	Conversion index	Type
6-63	Terminal X30/8 Output Bus Control	0 %	All set-ups	TRUE	-2	N2
6-64	Terminal X30/8 Output Timeout Preset	0 %	1 set-up	TRUE	-2	Uint16

6.16.8 7-** Controllers

Par. No. #	Parameter description	Default value	4-set-up	Change during operation	Conversion index	Type
7-0* Speed PID Ctrl.						
7-00	Speed PID Feedback Source	null	All set-ups	FALSE	-	Uint8
7-02	Speed PID Proportional Gain	App.Dependent	All set-ups	TRUE	-3	Uint16
7-03	Speed PID Integral Time	App.Dependent	All set-ups	TRUE	-4	Uint32
7-04	Speed PID Differentiation Time	App.Dependent	All set-ups	TRUE	-4	Uint16
7-05	Speed PID Diff. Gain Limit	5.0 N/A	All set-ups	TRUE	-1	Uint16
7-06	Speed PID Lowpass Filter Time	App.Dependent	All set-ups	TRUE	-4	Uint16
7-07	Speed PID Feedback Gear Ratio	1.0000 N/A	All set-ups	FALSE	-4	Uint32
7-08	Speed PID Feed Forward Factor	0%	All set-ups	FALSE	0	Uint16
7-09	Speed PID Error Correction w/ Ramp	300RPM	All set-ups	TRUE	67	Uint32
7-1* Torque PI Ctrl.						
7-12	Torque PI Proportional Gain	100%	All set-ups	TRUE	0	Uint16
7-13	Torque PI Integration Time	0.020 s	All set-ups	TRUE	-3	Uint16
7-2* Process Ctrl. Feedb						
7-20	Process CL Feedback 1 Resource	[0] No function	All set-ups	TRUE	-	Uint8
7-22	Process CL Feedback 2 Resource	[0] No function	All set-ups	TRUE	-	Uint8
7-3* Process PID Ctrl.						
7-30	Process PID Normal/ Inverse Control	[0] Normal	All set-ups	TRUE	-	Uint8
7-31	Process PID Anti Windup	[1] On	All set-ups	TRUE	-	Uint8
7-32	Process PID Start Speed	0 RPM	All set-ups	TRUE	67	Uint16
7-33	Process PID Proportional Gain	0.01 N/A	All set-ups	TRUE	-2	Uint16
7-34	Process PID Integral Time	10000.00 s	All set-ups	TRUE	-2	Uint32
7-35	Process PID Differentiation Time	0.00 s	All set-ups	TRUE	-2	Uint16
7-36	Process PID Diff. Gain Limit	5.0 N/A	All set-ups	TRUE	-1	Uint16
7-38	Process PID Feed Forward Factor	0%	All set-ups	TRUE	0	Uint16
7-39	On Reference Bandwidth	5%	All set-ups	TRUE	0	Uint8

6.16.9 8-** Comm. and Options

Par. No. #	Parameter description	Default value	4-set-up	Change during operation	Conversion index	Type
8-0* General Settings						
8-01	Control Site	[0] Digital and ctrl.word	All set-ups	TRUE	-	Uint8
8-02	Control Word Source	ExpressionLimit	All set-ups	TRUE	-	Uint8
8-03	Control Word Timeout Time	20 s	1 set-up	TRUE	-1	Uint32
8-04	Control Word Timeout Function	[0] Off	1 set-up	TRUE	-	Uint8
8-05	End-of-Timeout Function	[1] Resume set-up	1 set-up	TRUE	-	Uint8
8-06	Reset Control Word Timeout	[0] Do not reset	All set-ups	TRUE	-	Uint8
8-07	Diagnosis Trigger	[0] Disable	2 set-ups	TRUE	-	Uint8
8-1* Ctrl. Word Settings						
8-10	Control Word Profile	[0] FC profile	All set-ups	TRUE	-	Uint8
8-13	Configurable Status Word STW	[1] Profile Default	All set-ups	TRUE	-	Uint8
8-16	Store Data Values	[0] Off	All set-ups	TRUE	-	Uint8
8-3* FC Port Settings						
8-30	Protocol	[0] FC	1 set-up	TRUE	-	Uint8
8-31	Address	1 N/A	1 set-up	TRUE	0	Uint8
8-32	FC Port Baud Rate	ExpressionLimit	1 set-up	TRUE	-	Uint8
8-33	Parity / Stop Bits	ExpressionLimit	1 set-up	TRUE	-	Uint8
8-35	Minimum Response Delay	10 ms	1 set-up	TRUE	-3	Uint16
8-36	Max Response Delay	ExpressionLimit	1 set-up	TRUE	-3	Uint16
8-37	Max Inter-Char Delay	ExpressionLimit	1 set-up	TRUE	-5	Uint16
8-4* FC MC protocol set						
8-40	Telegram Selection	[1] Standard telegram 1	2 set-ups	TRUE	-	Uint8
8-42	PCD Write Configuration	ExpressionLimit	2 set-ups	TRUE	-	Uint16
8-43	PCD Read Configuration	ExpressionLimit	2 set-ups	TRUE	-	Uint16
8-5* Digital/Bus						
8-50	Coasting Select	[3] Logic OR	All set-ups	TRUE	-	Uint8
8-51	Quick Stop Select	[3] Logic OR	All set-ups	TRUE	-	Uint8
8-52	DC Brake Select	[3] Logic OR	All set-ups	TRUE	-	Uint8
8-53	Start Select	[3] Logic OR	All set-ups	TRUE	-	Uint8
8-54	Reversing Select	[3] Logic OR	All set-ups	TRUE	-	Uint8
8-55	Set-up Select	[3] Logic OR	All set-ups	TRUE	-	Uint8
8-56	Preset Reference Select	[3] Logic OR	All set-ups	TRUE	-	Uint8
8-8* FC Port Diagnostics						
8-80	Bus Message Count	0 N/A	All set-ups	TRUE	0	Uint32
8-81	Bus Error Count	0 N/A	All set-ups	TRUE	0	Uint32
8-82	Slave Messages Rcvd	0 N/A	All set-ups	TRUE	0	Uint32
8-83	Slave Error Count	0 N/A	All set-ups	TRUE	0	Uint32
8-9* Bus Jog						
8-90	Bus Jog 1 Speed	100 RPM	All set-ups	TRUE	67	Uint16
8-91	Bus Jog 2 Speed	200 RPM	All set-ups	TRUE	67	Uint16

6.16.10 14-** Special Functions

Par. No. #	Parameter description	Default value	4-set-up	Change during operation	Conversion index	Type
14-0* Inverter Switching						
14-00	Switching Pattern	[1] SFAVM	All set-ups	TRUE	-	Uin8
14-01	Switching Frequency	ExpressionLimit	All set-ups	TRUE	-	Uin8
14-03	Overmodulation	ExpressionLimit	All set-ups	FALSE	-	Uin8
14-04	PWM Random	[0] Off	All set-ups	TRUE	-	Uin8
14-1* Mains On/Off						
14-10	Mains Failure	ExpressionLimit	All set-ups	FALSE	-	Uin8
14-11	Mains Voltage at Mains Fault	ExpressionLimit	All set-ups	TRUE	0	Uin16
14-12	Function at Mains Imbalance	[1] Warning	All set-ups	TRUE	-	Uin8
14-13	Mains Failure Step Factor	1 N/A	All set-ups	TRUE	-1	Uin8
14-2* Trip Reset						
14-20	Reset Mode	[10] Automatic reset x 10	All set-ups	TRUE	-	Uin8
14-21	Automatic Restart Time	30 s	All set-ups	TRUE	0	Uin16
14-22	Operation Mode	[0] Normal operation	All set-ups	TRUE	-	Uin8
14-23	Typecode Setting	ExpressionLimit	2 set-ups	FALSE	-	Uin8
14-25	Trip Delay at Torque Limit	60 s	All set-ups	TRUE	0	Uin8
14-26	Trip Delay at Inverter Fault	ExpressionLimit	All set-ups	TRUE	0	Uin8
14-28	Production Settings	[0] No action	All set-ups	TRUE	-	Uin8
14-29	Service Code	0 N/A	All set-ups	TRUE	0	Int32
14-3* Current Limit Ctrl.						
14-30	Current Lim Cont, Proportional Gain	100 %	All set-ups	FALSE	0	Uin16
14-31	Current Lim Contr, Integration Time	0.020 s	All set-ups	FALSE	-3	Uin16
14-32	Current Lim Ctrl, Filter Time	26 ms	All set-ups	TRUE	-4	Uin16
14-4* Energy Optimizing						
14-40	VT Level	66 %	All set-ups	FALSE	0	Uin8
14-41	AEO Minimum Magnetisation	40 %	All set-ups	TRUE	0	Uin8
14-42	Minimum AEO Frequency	30 Hz	All set-ups	TRUE	0	Uin8
14-43	Motor Cosphi	ExpressionLimit	All set-ups	TRUE	-2	Uin16
14-5* Environment						
14-50	RFI Filter	[1] On	1 set-up	FALSE	-	Uin8
14-52	Fan Control	[0] Auto	All set-ups	TRUE	-	Uin8
14-53	Fan Monitor	[0] Disabled	All set-ups	TRUE	-	Uin8
14-55	Output Filter	[0] No Filter	1 set-up	FALSE	-	Uin8
14-56	Capacitance Output Filter	2 uF	1 set-up	FALSE	-7	Uin16
14-57	Inductance Output Filter	7 mH	1 set-up	FALSE	-6	Uin16
14-6* Auto Derate						
14-60	Function at Over Temperature	[1] Derate	All set-ups	TRUE	-	Uin8
14-61	Function at Inverter Overload	[1] Derate	All set-ups	TRUE	-	Uin8
14-62	Inv. Overload Derate Current	95 %	All set-ups	TRUE	0	Uin16
14-9* Fault Settings						
14-90	Fault Level	ExpressionLimit	1 set-up	TRUE	-	Uin8

6.16.11 15-** Drive Information

Par. No. #	Parameter description	Default value	4-set-up	Change during operation	Conversion index	Type
15-0* Operating Data						
15-00	Operating hours	0 h	All set-ups	FALSE	74	Uint32
15-01	Running Hours	0 h	All set-ups	FALSE	74	Uint32
15-02	kWh Counter	0 kWh	All set-ups	FALSE	75	Uint32
15-03	Power Up's	0 N/A	All set-ups	FALSE	0	Uint32
15-04	Over Temp's	0 N/A	All set-ups	FALSE	0	Uint16
15-05	Over Volt's	0 N/A	All set-ups	FALSE	0	Uint16
15-06	Reset kWh Counter	[0] Do not reset	All set-ups	TRUE	-	Uint8
15-07	Reset Running Hours Counter	[0] Do not reset	All set-ups	TRUE	-	Uint8
15-08	Number of Starts	0 N/A	All set-ups	FALSE	0	Uint32
15-1* Data Log Settings						
15-10	Logging Source	0	2 set-ups	TRUE	-	Uint16
15-11	Logging Interval	ExpressionLimit	2 set-ups	TRUE	-3	TimD
15-12	Trigger Event	[0] False	1 set-up	TRUE	-	Uint8
15-13	Logging Mode	[0] Log always	2 set-ups	TRUE	-	Uint8
15-14	Samples Before Trigger	50 N/A	2 set-ups	TRUE	0	Uint8
15-2* Historic Log						
15-20	Historic Log: Event	0 N/A	All set-ups	FALSE	0	Uint8
15-21	Historic Log: Value	0 N/A	All set-ups	FALSE	0	Uint32
15-22	Historic Log: Time	0 ms	All set-ups	FALSE	-3	Uint32
15-23	Historic log: Date and Time	ExpressionLimit	All set-ups	FALSE	0	TimeOfDay
15-3* Alarm Log						
15-30	Alarm Log: Error Code	0 N/A	All set-ups	FALSE	0	Uint8
15-31	Alarm Log: Value	0 N/A	All set-ups	FALSE	0	Int16
15-32	Alarm Log: Time	0 s	All set-ups	FALSE	0	Uint32
15-33	Alarm Log: Date and Time	ExpressionLimit	All set-ups	FALSE	0	TimeOfDay
15-34	Alarm Log: Status	0 N/A	All set-ups	FALSE	0	Uint8
15-35	Alarm Log: Alarm Text	0 N/A	All set-ups	FALSE	0	VisStr[32]
15-4* Drive Identification						
15-40	FC Type	0 N/A	All set-ups	FALSE	0	VisStr[6]
15-41	Power Section	0 N/A	All set-ups	FALSE	0	VisStr[20]
15-42	Voltage	0 N/A	All set-ups	FALSE	0	VisStr[20]
15-43	Software Version	0 N/A	All set-ups	FALSE	0	VisStr[5]
15-44	Ordered Typecode String	0 N/A	All set-ups	FALSE	0	VisStr[40]
15-45	Actual Typecode String	0 N/A	All set-ups	FALSE	0	VisStr[40]
15-46	Frequency Converter Ordering No	0 N/A	All set-ups	FALSE	0	VisStr[8]
15-47	Power Card Ordering No	0 N/A	All set-ups	FALSE	0	VisStr[8]
15-48	LCP Id No	0 N/A	All set-ups	FALSE	0	VisStr[20]
15-49	SW ID Control Card	0 N/A	All set-ups	FALSE	0	VisStr[20]
15-50	SW ID Power Card	0 N/A	All set-ups	FALSE	0	VisStr[20]
15-51	Frequency Converter Serial Number	0 N/A	All set-ups	FALSE	0	VisStr[10]
15-53	Power Card Serial Number	0 N/A	All set-ups	FALSE	0	VisStr[19]
15-6* Option Ident						
15-60	Option Mounted	0 N/A	All set-ups	FALSE	0	VisStr[30]
15-61	Option SW Version	0 N/A	All set-ups	FALSE	0	VisStr[20]
15-62	Option Ordering No	0 N/A	All set-ups	FALSE	0	VisStr[8]

Par. No. #	Parameter description	Default value	4-set-up	Change during operation	Conversion index	Type
15-63	Option Serial No	0 N/A	All set-ups	FALSE	0	VisStr[18]
15-70	Option in Slot A	0 N/A	All set-ups	FALSE	0	VisStr[30]
15-71	Slot A Option SW Version	0 N/A	All set-ups	FALSE	0	VisStr[20]
15-72	Option in Slot B	0 N/A	All set-ups	FALSE	0	VisStr[30]
15-73	Slot B Option SW Version	0 N/A	All set-ups	FALSE	0	VisStr[20]
15-74	Option in Slot C0/E0	0 N/A	All set-ups	FALSE	0	VisStr[30]
15-75	Slot C0/E0 Option SW Version	0 N/A	All set-ups	FALSE	0	VisStr[20]
15-76	Option in Slot C1/E1	0 N/A	All set-ups	FALSE	0	VisStr[30]
15-77	Slot C1/E1 Option SW Version	0 N/A	All set-ups	FALSE	0	VisStr[20]
15-9* Parameter Info						
15-92	Defined Parameters	0 N/A	All set-ups	FALSE	0	Uint16
15-93	Modified Parameters	0 N/A	All set-ups	FALSE	0	Uint16
15-99	Parameter Metadata	0 N/A	All set-ups	FALSE	0	Uint16

6.16.12 16-** Data Readouts

Par. No. #	Parameter description	Default value	4-set-up	Change during operation	Conversion index	Type
16-0* General Status						
16-00	Control Word	0 N/A	All set-ups	FALSE	0	V2
16-01	Reference [Unit]	0 ReferenceFeedbackUnit	All set-ups	FALSE	-3	Int32
16-02	Reference [%]	0 %	All set-ups	FALSE	-1	Int16
16-03	Status Word	0 N/A	All set-ups	FALSE	0	V2
16-05	Main Actual Value [%]	0 %	All set-ups	FALSE	-2	N2
16-09	Custom Readout	0 CustomReadoutUnit	All set-ups	FALSE	-2	Int32
16-1* Motor Status						
16-10	Power [kW]	0 kW	All set-ups	FALSE	1	Int32
16-11	Power [hp]	0 hp	All set-ups	FALSE	-2	Int32
16-12	Motor Voltage	0 V	All set-ups	FALSE	-1	UInt16
16-13	Frequency	0 Hz	All set-ups	FALSE	-1	UInt16
16-14	Motor current	0 A	All set-ups	FALSE	-2	Int32
16-15	Frequency [%]	0 %	All set-ups	FALSE	-2	N2
16-16	Torque [Nm]	0 Nm	All set-ups	FALSE	-1	Int32
16-17	Speed [RPM]	0 RPM	All set-ups	FALSE	67	Int32
16-18	Motor Thermal	0 %	All set-ups	FALSE	0	UInt8
16-22	Torque [%]	0 %	All set-ups	FALSE	0	Int16
16-3* Drive Status						
16-30	DC Link Voltage	0 V	All set-ups	FALSE	0	UInt16
16-32	Brake Energy /s	0 kW	All set-ups	FALSE	0	UInt32
16-33	Brake Energy /2 min	0 kW	All set-ups	FALSE	0	UInt32
16-34	Heatsink Temp.	0 °C	All set-ups	FALSE	100	UInt8
16-35	Inverter Thermal	0 %	All set-ups	FALSE	0	UInt8
16-36	Inv. Nom. Current	ExpressionLimit	All set-ups	FALSE	-2	UInt32
16-37	Inv. Max. Current	ExpressionLimit	All set-ups	FALSE	-2	UInt32
16-38	SL Controller State	0 N/A	All set-ups	FALSE	0	UInt8
16-39	Control Card Temp.	0 °C	All set-ups	FALSE	100	UInt8
16-40	Logging Buffer Full	[0] No	All set-ups	TRUE	-	UInt8
16-41	LCP Bottom Statusline	0 N/A	All set-ups	TRUE	0	VisStr[50]
16-5* Ref. & Feedb.						
16-50	External Reference	0 N/A	All set-ups	FALSE	-1	Int16
16-52	Feedback[Unit]	0 ProcessCtrlUnit	All set-ups	FALSE	-3	Int32
16-53	Digi Pot Reference	0 N/A	All set-ups	FALSE	-2	Int16
16-54	Feedback 1 [Unit]	0 ProcessCtrlUnit	All set-ups	FALSE	-3	Int32
16-55	Feedback 2 [Unit]	0 ProcessCtrlUnit	All set-ups	FALSE	-3	Int32
16-56	Feedback 3 [Unit]	0 ProcessCtrlUnit	All set-ups	FALSE	-3	Int32
16-6* Inputs & Outputs						
16-60	Digital Input	0 N/A	All set-ups	FALSE	0	UInt16
16-61	Terminal 53 Switch Setting	[0] Current	All set-ups	FALSE	-	UInt8
16-62	Analog Input 53	0 N/A	All set-ups	FALSE	-3	Int32
16-63	Terminal 54 Switch Setting	[0] Current	All set-ups	FALSE	-	UInt8
16-64	Analog Input 54	0 N/A	All set-ups	FALSE	-3	Int32
16-65	Analog Output 42 [mA]	0 N/A	All set-ups	FALSE	-3	Int16
16-66	Digital Output [bin]	0 N/A	All set-ups	FALSE	0	Int16
16-67	Pulse Input #29 [Hz]	0 N/A	All set-ups	FALSE	0	Int32

Par. No. #	Parameter description	Default value	4-set-up	Change during operation	Conversion index	Type
16-68	Pulse Input #33 [Hz]	0 N/A	All set-ups	FALSE	0	Int32
16-69	Pulse Output #27 [Hz]	0 N/A	All set-ups	FALSE	0	Int32
16-70	Pulse Output #29 [Hz]	0 N/A	All set-ups	FALSE	0	Int32
16-71	Relay Output [bin]	0 N/A	All set-ups	FALSE	0	Int16
16-72	Counter A	0 N/A	All set-ups	TRUE	0	Int32
16-73	Counter B	0 N/A	All set-ups	TRUE	0	Int32
16-75	Analog In X30/11	0 N/A	All set-ups	FALSE	-3	Int32
16-76	Analog In X30/12	0 N/A	All set-ups	FALSE	-3	Int32
16-77	Analog Out X30/8 [mA]	0 N/A	All set-ups	FALSE	-3	Int16
16-8* Fieldbus & FC Port						
16-80	Fieldbus CTW 1	0 N/A	All set-ups	FALSE	0	V2
16-82	Fieldbus REF 1	0 N/A	All set-ups	FALSE	0	N2
16-84	Comm. Option STW	0 N/A	All set-ups	FALSE	0	V2
16-85	FC Port CTW 1	0 N/A	All set-ups	FALSE	0	V2
16-86	FC Port REF 1	0 N/A	All set-ups	FALSE	0	N2
16-9* Diagnosis Readouts						
16-90	Alarm Word	0 N/A	All set-ups	FALSE	0	UInt32
16-91	Alarm Word 2	0 N/A	All set-ups	FALSE	0	UInt32
16-92	Warning Word	0 N/A	All set-ups	FALSE	0	UInt32
16-93	Warning Word 2	0 N/A	All set-ups	FALSE	0	UInt32
16-94	Ext. Status Word	0 N/A	All set-ups	FALSE	0	UInt32
16-95	Ext. Status Word 2	0 N/A	All set-ups	FALSE	0	UInt32
16-96	Maintenance Word	0 N/A	All set-ups	FALSE	0	UInt32

6.16.13 25-** Cascade Controller

Par. No. #	Parameter description	Default value	4-set-up	Change during operation	Conversion index	Type
25-0* System Settings						
25-00	Pack Controller	[0] Disabled	2 set-ups	FALSE	-	Uint8
25-04	Compressor Cycling	[0] Disabled	All set-ups	TRUE	-	Uint8
25-06	Number of Compressors	2 N/A	2 set-ups	FALSE	0	Uint8
25-2* Zone Settings						
25-20	Neutral Zone [unit]	4 ReferenceFeedbackUnit	All set-ups	TRUE	-2	Uint32
25-21	+ Zone [unit]	3 ReferenceFeedbackUnit	All set-ups	TRUE	-2	Uint32
25-22	- Zone [unit]	3 ReferenceFeedbackUnit	All set-ups	TRUE	-2	Uint32
25-23	Fixed Speed neutral Zone [unit]	4 ReferenceFeedbackUnit	All set-ups	TRUE	-2	Uint32
25-24	+ Zone Delay	120 s	All set-ups	TRUE	0	Uint32
25-25	- Zone Delay	60 s	All set-ups	TRUE	0	Uint32
25-26	++ Zone Delay	60 s	All set-ups	TRUE	0	Uint32
25-27	-- Zone Delay	30 s	All set-ups	TRUE	0	Uint32
25-3* Staging Functions						
25-30	Destage At No-Flow	[0] Disabled	All set-ups	TRUE	-	Uint8
25-31	Stage Function	[0] Disabled	All set-ups	TRUE	-	Uint8
25-32	Stage Function Time	15 s	All set-ups	TRUE	0	Uint16
25-33	Destage Function	[0] Disabled	All set-ups	TRUE	-	Uint8
25-34	Destage Function Time	15 s	All set-ups	TRUE	0	Uint16
25-4* Staging Settings						
25-42	Staging Threshold	ExpressionLimit	All set-ups	TRUE	0	Uint8
25-43	Destaging Threshold	ExpressionLimit	All set-ups	TRUE	0	Uint8
25-44	Staging Speed [RPM]	0 RPM	All set-ups	TRUE	67	Uint16
25-45	Staging Speed [Hz]	0 Hz	All set-ups	TRUE	-1	Uint16
25-46	Destaging Speed [RPM]	0 RPM	All set-ups	TRUE	67	Uint16
25-47	Destaging Speed [Hz]	0 Hz	All set-ups	TRUE	-1	Uint16
25-8* Status						
25-80	Pack Status	0 N/A	All set-ups	TRUE	0	VisStr[25]
25-81	Compressor Status	0 N/A	All set-ups	TRUE	0	VisStr[25]
25-82	Lead Compressor	0 N/A	All set-ups	TRUE	0	Uint8
25-83	Relay Status	0 N/A	All set-ups	TRUE	0	VisStr[4]
25-84	Compressor ON Time	0 h	All set-ups	TRUE	74	Uint32
25-85	Relay ON Time	0 h	All set-ups	TRUE	74	Uint32
25-86	Reset Relay Counters	[0] Do not reset	All set-ups	TRUE	-	Uint8
25-87	Inverse Interlock	0 N/A	All set-ups	TRUE	0	Uint16
25-88	Pack capacity [%]	0 %	All set-ups	TRUE	0	Uint16
25-9* Service						
25-90	Compressor Interlock	[0] Off	All set-ups	TRUE	-	Uint8
25-91	Manual Alternation	0 N/A	All set-ups	TRUE	0	Uint8

6.16.14 28-** Compressor Function

Par. No. #	Parameter description	Default value	4-set-up	Change during operation	Conversion index	Type
28-0* Short Cycle Protection						
28-00	Short Cycle Protection	[1] Enabled	All set-ups	TRUE	-	Uint8
28-01	Interval between Starts	300 s	All set-ups	TRUE	0	Uint16
28-02	Minimum Run Time	12 s	All set-ups	TRUE	0	Uint16
28-1* Oil Return Management						
28-10	Oil Return Management	ExpressionLimit	All set-ups	FALSE	-	Uint8
28-11	Low Speed Running Time	60 min	All set-ups	TRUE	70	Uint16
28-12	Fixed Boost Interval	24 h	All set-ups	TRUE	74	Uint8
28-13	Boost Duration	30 s	All set-ups	FALSE	0	Uint8
28-2* Discharge Temperature Monitor						
28-20	Temperature Source	[0] None	All set-ups	FALSE	-	Uint8
28-21	Temperature Unit	[60] °C	All set-ups	FALSE	-	Uint8
28-24	Warning Level	130 N/A	All set-ups	FALSE	0	Uint16
28-25	Warning Action	[1] Decrease cooling	All set-ups	FALSE	-	Uint8
28-26	Emergency Level	145 N/A	All set-ups	FALSE	0	Uint16
28-27	Discharge Temperature	0 DTM_ReadoutUnit	All set-ups	TRUE	0	Int32
28-3* Crankcase Heating						
28-30	Crankcase Heating Control	ExpressionLimit	All set-ups	TRUE	-	Uint8
28-31	Heating DC Current	ExpressionLimit	All set-ups	TRUE	0	Uint8
28-32	Crankcase Heating Delay	5 s	All set-ups	TRUE	0	Uint16
28-4* Anti-reverse Protection at Stop						
28-40	Reverse Protection Control	[0] Disabled	All set-ups	TRUE	-	Uint8
28-41	DC Brake Current	90 %	All set-ups	TRUE	0	Uint16
28-42	DC Braking Time	ExpressionLimit	All set-ups	TRUE	-1	Uint16
28-43	DC Brake Cut In Speed [RPM]	ExpressionLimit	All set-ups	TRUE	67	Uint16
28-44	DC Brake Cut In Speed [Hz]	ExpressionLimit	All set-ups	TRUE	-1	Uint16
28-5* Load Profile						
28-50	Reset Load Profile	[0] Do not reset	All set-ups	TRUE	-	Uint8
28-59	Load Profile Data	0 N/A	All set-ups	TRUE	0	Uint16
28-7* Day/Night Settings						
28-74	Night Speed Drop [RPM]	ExpressionLimit	All set-ups	TRUE	67	Uint16
28-76	Night Speed Drop [Hz]	ExpressionLimit	All set-ups	TRUE	-1	Uint16

7 Troubleshooting

7.1 Status Messages

7.1.1 Warnings/Alarm Messages

A warning or an alarm is signaled by the relevant LED on the front of the frequency converter and indicated by a code on the display.

A warning remains active until its cause is no longer present. Under certain circumstances, operation of the motor may still be continued. Warning messages may be critical, but are not necessarily so.

In the event of an alarm, the frequency converter trips. Reset the alarm to resume operation once the cause has been rectified.

Three ways to reset:

- Press [Reset].
- Via a digital input with the "Reset" function.
- Via serial communication/optional fieldbus.

NOTICE!

After a manual reset pressing [Reset], press [Auto On] to restart the motor.

If an alarm cannot be reset, the reason may be that its cause has not been rectified, or the alarm is trip-locked (see also *Table 7.1*).

Alarms that are trip-locked offer additional protection, meaning that the mains supply must be switched off before the alarm can be reset. After being switched back on, the frequency converter is no longer blocked and can be reset as described above once the cause has been rectified.

Alarms that are not trip-locked can also be reset using the automatic reset function in *parameter 14-20 Reset Mode* (Warning: automatic wake-up is possible!)

If a warning or alarm is marked against a code in *Table 7.1*, this means that either a warning occurs before an alarm, or else that it is possible to specify whether a warning or an alarm should be displayed for a given fault.

This is possible, for instance, in *parameter 1-90 Motor Thermal Protection*. After an alarm or trip, the motor carries on coasting, and the alarm and warning flash. Once the problem has been rectified, only the alarm continues flashing until the frequency converter is reset.

NOTICE!

No missing motor phase detection (numbers 30-32) and no stall detection is active when *parameter 1-10 Motor Construction* is set to [1] *PM non salient SPM*.

No.	Description	Warning	Alarm/Trip	Alarm/Trip Lock	Parameter Reference
1	10 Volts low	X			
2	Live zero error	(X)	(X)		Parameter 6-01 Live Zero Timeout Function
3	No motor	(X)			Parameter 1-80 Function at Stop
4	Mains phase loss	(X)	(X)	(X)	Parameter 14-12 Function at Mains Imbalance
5	DC link voltage high	X			
6	DC link voltage low	X			
7	DC over-voltage	X	X		
8	DC under voltage	X	X		
9	Inverter overloaded	X	X		
10	Motor ETR over temperature	(X)	(X)		Parameter 1-90 Motor Thermal Protection

No.	Description	Warning	Alarm/Trip	Alarm/Trip Lock	Parameter Reference
11	Motor thermistor over temperature	(X)	(X)		Parameter 1-90 Motor Thermal Protection
12	Torque limit	X	X		
13	Over Current	X	X	X	
14	Ground Fault	X	X		
15	Hardware mismatch		X	X	
16	Short Circuit		X	X	
17	Control word time-out	(X)	(X)		Parameter 8-04 Control Word Timeout Function
20	Temp. Input Error				
21	Param Error				
22	Hoist Mech. Brake	(X)	(X)		Parameter group 2-2*
23	Internal Fans	X			
24	External Fans	X			
25	Brake resistor short-circuited	X			
26	Brake resistor power limit	(X)	(X)		Parameter 2-13 Brake Power Monitoring
27	Brake chopper short-circuited	X	X		
28	Brake check	(X)	(X)		Parameter 2-15 Brake Check
29	Heatsink temp	X	X	X	
30	Motor phase U missing	(X)	(X)	(X)	Parameter 4-58 Missing Motor Phase Function
31	Motor phase V missing	(X)	(X)	(X)	Parameter 4-58 Missing Motor Phase Function
32	Motor phase W missing	(X)	(X)	(X)	Parameter 4-58 Missing Motor Phase Function
33	Inrush Fault		X	X	
34	Fieldbus communication fault	X	X		
35	Option Fault				
36	Mains failure	X	X		
37	Phase imbalance		X		
38	Internal Fault		X	X	
39	Heatsink sensor		X	X	
40	Overload of Digital Output Terminal 27	(X)			Parameter 5-00 Digital I/O Mode, parameter 5-01 Terminal 27 Mode
41	Overload of Digital Output Terminal 29	(X)			Parameter 5-00 Digital I/O Mode, parameter 5-02 Terminal 29 Mode
42	Ovrlid X30/6-7	(X)			
43	Ext. Supply (option)				
45	Ground Fault 2	X	X		
46	Pwr. card supply		X	X	
47	24 V supply low	X	X	X	
48	1.8 V supply low		X	X	
49	Speed limit		X		parameter 1-86 Trip Speed Low [RPM]

No.	Description	Warning	Alarm/Trip	Alarm/Trip Lock	Parameter Reference
50	AMA calibration failed		X		
51	AMA check U_{nom} and I_{nom}		X		
52	AMA low I_{nom}		X		
53	AMA motor too big		X		
54	AMA motor too small		X		
55	AMA parameter out of range		X		
56	AMA interrupted by user		X		
57	AMA time-out		X		
58	AMA internal fault	X	X		
59	Current limit	X			
60	External Interlock	X	X		
61	Feedback Error	(X)	(X)		Parameter 4-30 Motor Feedback Loss Function
62	Output Frequency at Maximum Limit	X			
63	Mechanical Brake Low		(X)		Parameter 2-20 Release Brake Current
64	Voltage Limit	X			
65	Control Board Over-temperature	X	X	X	
66	Heat sink Temperature Low	X			
67	Option Configuration has Changed		X		
68	Safe Stop	(X)	(X) ¹⁾		Parameter 5-19 Terminal 37 Safe Stop
69	Pwr. Card Temp		X	X	
70	Illegal FC configuration			X	
71	PTC 1 Safe Stop				
72	Dangerous failure				
73	Safe Stop Auto Restart	(X)	(X)		Parameter 5-19 Terminal 37 Safe Stop
74	PTC Thermistor			X	
75	Illegal Profile Sel.		X		
76	Power Unit Setup	X			
77	Reduced power mode	X			Parameter 14-59 Actual Number of Inverter Units
78	Tracking Error	(X)	(X)		Parameter 4-34 Tracking Error Function
79	Illegal PS config		X	X	
80	Drive Initialized to Default Value		X		
81	CSIV corrupt		X		
82	CSIV parameter error		X		
83	Illegal Option Combination			X	
84	No Safety Option		X		
85	Dang fail PB				
86	Dang fail DI				
88	Option Detection			X	
89	Mechanical Brake Sliding	X			
90	Feedback Monitor	(X)	(X)		Parameter 17-61 Feedback Signal Monitoring
91	Analog input 54 wrong settings			X	S202

No.	Description	Warning	Alarm/Trip	Alarm/Trip Lock	Parameter Reference
102	Too many CAN objects				
103	Illegal axis num.				
104	Mixing Fans				
105	Error not reset				
106	HOME not done				
107	Home vel zero				
108	Position error				
109	Index not found				
110	Unknown cmd.				
111	SW end limit				
112	Unknown param				
113	FC not enabled				
114	Too many loops				
115	Par.save failed				
116	Param. memory				
117	Progr. Memory				
118	Reset by CPU				
119	User abort				
121	No more SDO channels				
125	HW end limit				
149	Too many inter.				
150	No ext. 24 V				
151	GOSUB > limit				
152	Return @ limit				
154	D.out overload				
155	LINK failed				
156	Illegal double arg.				
160	Internal Intr. error				
162	Memory error				
163	ATEX ETR cur.lim.warning	X			
164	ATEX ETR cur.lim.alarm		X		
165	ATEX ETR freq.lim.warning	X			
166	ATEX ETR freq.lim.alarm		X		
246	Pwr.card supply				
250	New spare parts			X	
251	New Type Code		X	X	

Table 7.1 Alarm/Warning Code List
(X) Dependent on parameter
1) Cannot be Auto reset via parameter 14-20 Reset Mode

A trip is the action following an alarm. The trip coasts the motor and is reset by pressing [Reset] or by a digital input (parameter group 5-1* *Digital Inputs* [1]). The origin event that caused an alarm cannot damage the frequency converter or cause dangerous conditions. A trip lock is an action when an alarm occurs, which could damage the frequency converter or connected parts. A trip lock situation can only be reset by a power cycling.

Warning	yellow
Alarm	flashing red
Trip locked	yellow and red

Table 7.2 LED Indication

Bit	Hex	Dec	Alarm Word	Alarm Word 2	Warning Word	Warning Word 2	Extended Status Word	Extended Status Word 2
Alarm Word Extended Status Word								
0	00000001	1	Brake Check (A28)	ServiceTrip, Read/Write	Brake Check (W28)	Start Delayed	Ramping	Off
1	00000002	2	Pwr.card temp (A69)	ServiceTrip, (reserved)	Pwr.card temp (A69)	Stop Delayed	AMA Running	Hand/Auto
2	00000004	4	Ground Fault (A14)	ServiceTrip, Typecode/ Sparepart	Ground Fault (W14)	reserved	Start CW/CCW start_possible is active, when the DI selections [12] OR [13] are active and the requested direction matches the reference sign	Profibus OFF1 active
3	00000008	8	Ctrl.Card Temp (A65)	ServiceTrip, (reserved)	Ctrl.Card Temp (W65)	reserved	Slow Down slow down command active, e.g. via CTW bit 11 or DI	Profibus OFF2 active
4	00000010	16	Ctrl. Word TO (A17)	ServiceTrip, (reserved)	Ctrl. Word TO (W17)		Catch Up catch up command active, e.g. via CTW bit 12 or DI	Profibus OFF3 active
5	00000020	32	Over Current (A13)	reserved	Over Current (W13)	reserved	Feedback High feedback > 4-57	Relay 123 active
6	00000040	64	Torque Limit (A12)	reserved	Torque Limit (W12)	reserved	Feedback Low feedback < 4-56	Start Prevented
7	00000080	128	Motor Th Over (A11)	reserved	Motor Th Over (W11)	reserved	Output Current High current > 4-51	Control Ready
8	00000100	256	Motor ETR Over (A10)	reserved	Motor ETR Over (W10)	reserved	Output Current Low current < 4-50	Drive Ready
9	00000200	512	Inverter Overld. (A9)	Discharge High	Inverter Overld (W9)	Discharge High	Output Freq High speed > 4-53	Quick Stop
10	00000400	1024	DC under Volt (A8)	Start Failed	DC under Volt (W8)	Multi-motor underload	Output Freq Low speed < 4-52	DC Brake

Bit	Hex	Dec	Alarm Word	Alarm Word 2	Warning Word	Warning Word 2	Extended Status Word	Extended Status Word 2
11	00000800	2048	DC over Volt (A7)	Speed Limit	DC over Volt (W7)	Multi-motor Overload	Brake Check OK brake test NOT ok	Stop
12	00001000	4096	Short Circuit (A16)	External Interlock	DC Voltage Low (W6)	Compressor Interlock	Braking Max BrakePower > BrakePowerLimit (2-12)	Stand by
13	00002000	8192	Inrush Fault (A33)	Illegal Option Combi.	DC Voltage High (W5)	Mechanical Brake Sliding	Braking	Freeze Output Request
14	00004000	16384	Mains ph. Loss (A4)	No Safety Option	Mains ph. Loss (W4)	Safe Option Warning	Out of Speed Range	Freeze Output
15	00008000	32768	AMA Not OK	reserved	No Motor (W3)	Auto DC Braking	OVC Active	Jog Request
16	00010000	65536	Live Zero Error (A2)	reserved	Live Zero Error (W2)		AC Brake	Jog
17	00020000	131072	Internal Fault (A38)	KTY error	10V Low (W1)	KTY Warn	Password Timelock number of allowed password trials exceeded - timelock active	Start Request
18	00040000	262144	Brake Overload (A26)	Fans error	Brake Overload (W26)	Fans Warn	Password Protection 0-61 = ALL_NO_ACCESS OR BUS_NO_ACCESS OR BUS_READONLY	Start
19	00080000	524288	U phase Loss (A30)	ECB error	Brake Resistor (W25)	ECB Warn	Reference High reference > 4-55	Start Applied
20	00100000	1048576	V phase Loss (A31)	reserved	Brake IGBT (W27)	reserved	Reference Low reference < 4-54	Start delay
21	00200000	2097152	W phase Loss (A32)	reserved	Speed Limit (W49)	reserved	Local Reference reference site = REMOTE -> auto on pressed & active	Sleep
22	00400000	4194304	Fieldbus Fault (A34)	reserved	Fieldbus Fault (W34)	reserved	Protection mode notifikation	Sleep Boost
23	00800000	8388608	24 V Supply Low (A47)	reserved	24V Supply Low (W47)	reserved	Unused	Running
24	01000000	16777216	Mains Failure (A36)	reserved	Mains Failure (W36)	reserved	Unused	Drive Bypass
25	02000000	33554432	1.8V Supply Low (A48)	Current Limit (A59)	Current Limit (W59)	reserved	Unused	Fire Mode
26	04000000	67108864	Brake Resistor (A25)	reserved	Low Temp (W66)	reserved	Unused	External Interlock

Bit	Hex	Dec	Alarm Word	Alarm Word 2	Warning Word	Warning Word 2	Extended Status Word	Extended Status Word 2
27	08000000	134217728	Brake IGBT (A27)	reserved	Voltage Limit (W64)	reserved	Unused	Firemode Limit Exceed
28	10000000	268435456	Option Change (A67)	reserved	Encoder loss (W90)	reserved	Unused	FlyStart active
29	20000000	536870912	Drive Initialized(A80)	Encoder loss (A90)	Output freq. lim. (W62)	BackEMF too High	Unused	
30	40000000	1073741824	Safe Stop (A68)	PTC Thermistor (A74)	Safe Stop (W68)	PTC Thermist or (W74)	Unused	
31	80000000	2147483648	Mech. brake low (A63)	Dangerous failure (A72)	Extended Status Word		Protection Mode	

Table 7.3 Description of Alarm Word, Warning Word and Extended Status Word

The alarm words, warning words and extended status words can be read out via serial bus or optional fieldbus for diagnostics. See also *parameter 16-94 Ext. Status Word*.

WARNING 1, 10 Volts low

The control card voltage is below 10 V from terminal 50. Remove some of the load from terminal 50, as the 10 V supply is overloaded. Max. 15 mA or minimum 590 Ω.

This condition can be caused by a short in a connected potentiometer or improper wiring of the potentiometer.

Troubleshooting

Remove the wiring from terminal 50. If the warning clears, the problem is with the customer wiring. If the warning does not clear, replace the control card.

WARNING/ALARM 2, Live zero error

This warning or alarm only appears if programmed by the user in *parameter 6-01 Live Zero Timeout Function*. The signal on one of the analog inputs is less than 50% of the minimum value programmed for that input. Broken wiring or faulty device sending the signal can cause this condition.

Troubleshooting

Check connections on all the analog input terminals. Control card terminals 53 and 54 for signals, terminal 55 common. MCB 101 terminals 11 and 12 for signals, terminal 10 common. MCB 109 terminals 1, 3, 5 for signals, terminals 2, 4, 6 common.

Check that the adjustable frequency drive programming and switch settings match the analog signal type.

Perform Input Terminal Signal Test.

WARNING/ALARM 3, No motor

No motor has been connected to the output of the frequency converter.

WARNING/ALARM 4, Mains phase loss

A phase is missing on the supply side, or the line voltage imbalance is too high. This message also appears for a fault in the input rectifier on the adjustable frequency drive. Options are programmed at *parameter 14-12 Function at Mains Imbalance*.

Troubleshooting

Check the supply voltage and supply currents to the adjustable frequency drive.

WARNING 5, DC link voltage high

The intermediate circuit voltage (DC) is higher than the high voltage warning limit. The limit is dependent on the adjustable frequency drive voltage rating. The unit is still active.

WARNING 6, DC link voltage low

The intermediate circuit voltage (DC) is lower than the low voltage warning limit. The limit is dependent on the adjustable frequency drive voltage rating. The unit is still active.

WARNING/ALARM 7, DC overvoltage

If the intermediate circuit voltage exceeds the limit, the frequency converter trips after a time.

Troubleshooting

Connect a brake resistor

Extend the ramp time

Change the ramp type

Activate the functions in *parameter 2-10 Brake Function*

Increase *parameter 14-26 Trip Delay at Inverter Fault*

If the alarm/warning occurs during a power sag, use kinetic back-up (*parameter 14-10 Line Failure*)

WARNING/ALARM 8, DC under voltage

If the intermediate circuit voltage (DC link) drops below the undervoltage limit, the adjustable frequency drive checks if a 24 V DC backup supply is connected. If no 24 V DC backup supply is connected, the adjustable frequency drive trips after a fixed time delay. The time delay varies with unit size.

Troubleshooting

Make sure that the supply voltage matches the adjustable frequency drive voltage.

Perform input voltage test.

Perform soft charge circuit test.

WARNING/ALARM 9, Inverter overload

The adjustable frequency drive is about to cut out because of an overload (current too high for too long). The counter for electronic, thermal inverter protection issues a warning at 98% and trips at 100%, while giving an alarm. The adjustable frequency drive *cannot* be reset until the counter is below 90%.

The fault is that the adjustable frequency drive has run with more than 100% overload for too long.

Troubleshooting

Compare the output current shown on the LCP with the adjustable frequency drive rated current.

Compare the output current shown on the LCP with measured motor current.

Display the Thermal Drive Load on the LCP and monitor the value. When running above the adjustable frequency drive continuous current rating, the counter increases. When running below the adjustable frequency drive continuous current rating, the counter decreases.

WARNING/ALARM 10, Motor overload temperature

According to the electronic thermal protection (ETR), the motor is too hot. Select whether the adjustable frequency drive issues a warning or an alarm when the counter reaches 100% in *parameter 1-90 Motor Thermal Protection*. The fault occurs when the motor runs with more than 100% overload for too long.

Troubleshooting

Check for motor overheating.

Check if the motor is mechanically overloaded

Check that the motor current set in *parameter 1-24 Motor Current* is correct.

Ensure that Motor data in parameters 1-20 to 1-25 are set correctly.

If an external fan is in use, check in *parameter 1-91 Motor External Fan* that it is selected.

Running AMA in *parameter 1-29 Automatic Motor Adaptation (AMA)* tunes the adjustable frequency drive to the motor more accurately and reduces thermal loading.

WARNING/ALARM 11, Motor thermistor over temp

Check whether the thermistor is disconnected. Select whether the adjustable frequency drive issues a warning or an alarm in *parameter 1-90 Motor Thermal Protection*.

Troubleshooting

Check for motor overheating.

Check if the motor is mechanically overloaded.

When using terminal 53 or 54, check that the thermistor is connected correctly between either terminal 53 or 54 (analog voltage input) and terminal 50 (+10 V supply). Also check that the terminal switch for 53 or 54 is set for voltage. Check *parameter 1-93 Thermistor Source* selects terminal 53 or 54.

When using digital inputs 18 or 19, check that the thermistor is connected correctly between either terminal 18 or 19 (digital input PNP only) and terminal 50. Check *parameter 1-93 Thermistor Source* selects terminal 18 or 19.

WARNING/ALARM 12, Torque limit

The torque has exceeded the value in *parameter 4-16 Torque Limit Motor Mode* or the value in *parameter 4-17 Torque Limit Generator Mode*. *Parameter 14-25 Trip Delay at Torque Limit* can change this from a warning only condition to a warning followed by an alarm.

Troubleshooting

If the motor torque limit is exceeded during ramp-up, extend the ramp-up time.

If the generator torque limit is exceeded during ramp-down, extend the ramp-down time.

If torque limit occurs while running, possibly increase the torque limit. Make sure that the system can operate safely at a higher torque.

Check the application for excessive current draw on the motor.

WARNING/ALARM 13, Over current

The inverter peak current limit (approximately 200% of the rated current) is exceeded. The warning lasts about 1.5 s, then the adjustable frequency drive trips and issues an alarm. This fault can be caused by shock loading or quick acceleration with high inertia loads. It can also appear after

kinetic backup if the acceleration during ramp-up is quick. If extended mechanical brake control is selected, trip can be reset externally.

Troubleshooting

Remove power and check if the motor shaft can be turned.

Make sure that the motor size matches the adjustable frequency drive.

Check parameters 1-20 to 1-25 for correct motor data.

ALARM 14, Earth (ground) fault

There is current from the output phases to ground, either in the cable between the adjustable frequency drive and the motor or in the motor itself.

Troubleshooting:

Remove power to the adjustable frequency drive and repair the ground fault.

Check for ground faults in the motor by measuring the resistance to ground of the motor leads and the motor with a megohmmeter.

ALARM 15, Hardware mismatch

A fitted option is not operational with the present control board hardware or software.

Record the value of the following parameters and contact your Danfoss supplier:

parameter 15-40 FC Type

parameter 15-41 Power Section

parameter 15-42 Voltage

parameter 15-43 Software Version

parameter 15-45 Actual Typecode String

parameter 15-49 SW ID Control Card

parameter 15-50 SW ID Power Card

parameter 15-60 Option Mounted

parameter 15-61 Option SW Version (for each option slot)

ALARM 16, Short circuit

There is short-circuiting in the motor or motor wiring.

Remove power to the adjustable frequency drive and repair the short circuit.

WARNING/ALARM 17, Control word timeout

There is no communication to the frequency converter. The warning is only active when *parameter 8-04 Control Word Timeout Function* is NOT set to [0] Off.

If *parameter 8-04 Control Word Timeout Function* is set to [5] Stop and Trip, a warning appears and the frequency converter ramps down until it stops then displays an alarm.

Troubleshooting

Check connections on the serial communication cable.

Increase *parameter 8-03 Control Word Timeout Time*

Check the operation of the communication equipment.

Verify a proper installation based on EMC requirements.

ALARM 18, Start failed

The speed has not exceeded *parameter 1-77 Compressor Start Max Speed [RPM]* during start within the allowed time. (set in *parameter 1-79 Compressor Start Max Time to Trip*). This may be caused by a blocked motor.

Warning/Alarm 19, Discharge Temperature High

Warning:

The discharge temperature exceeds the level programmed in *28-25 Warning Level*.

Alarm:

The discharge temperature exceeds the level programmed in *28-26 Emergency Level*.

WARNING/ALARM 20, Temp. input error

The temperature sensor is not connected.

WARNING/ALARM 21, Parameter error

The parameter is out of range. The parameter number is reported in the LCP. The affected parameter must be set to a valid value.

WARNING/ALARM 22, Hoist mechanical brake

Report value shows what kind it is.

0 = The torque ref. was not reached before time-out.

1 = There was no brake feedback before time-out.

WARNING 23, Internal fan fault

The fan warning function is an extra protective function that checks if the fan is running/mounted. The fan warning can be disabled in *parameter 14-53 Fan Monitor ([0] Disabled)*.

For the D, E, and F Frame filters, the regulated voltage to the fans is monitored.

Troubleshooting

Check for proper fan operation.

Cycle power to the adjustable frequency drive and check that the fan operates briefly at start-up.

Check the sensors on the heatsink and control card.

WARNING 24, External fan fault

The fan warning function is an extra protective function that checks if the fan is running/mounted. The fan warning can be disabled in *parameter 14-53 Fan Monitor ([0] Disabled)*.

Troubleshooting

Check for proper fan operation.

Cycle power to the adjustable frequency drive and check that the fan operates briefly at start-up.

Check the sensors on the heatsink and control card.

Incorrect airflow clearance above and below the adjustable frequency drive.

Blocked airflow around the adjustable frequency drive.

Damaged heatsink fan.

Dirty heatsink.

ALARM 30, Motor phase U missing

Motor phase U between the adjustable frequency drive and the motor is missing.

Remove power from the adjustable frequency drive and check motor phase U.

ALARM 31, Motor phase V missing

Motor phase V between the adjustable frequency drive and the motor is missing.

Remove power from the adjustable frequency drive and check motor phase V.

ALARM 32, Motor phase W missing

Motor phase W between the adjustable frequency drive and the motor is missing.

Remove power from the adjustable frequency drive and check motor phase W.

ALARM 33, Inrush fault

Too many power-ups have occurred within a short time period. Let the unit cool to operating temperature.

WARNING/ALARM 34, Fieldbus communication fault

The serial communication bus on the communication option card is not working.

WARNING/ALARM 35, Option fault

An option alarm is received. The alarm is option-specific. The most likely cause is a power-up or a communication fault.

WARNING/ALARM 36, Mains failure

This warning/alarm is only active if the supply voltage to the adjustable frequency drive is lost and *parameter 14-10 Mains Failure* is NOT set to [0] *No Function*. Check the fuses to the adjustable frequency drive and line power supply to the unit.

ALARM 37, Phase imbalance

There is a current imbalance between the power units

ALARM 38, Internal fault

When an internal fault occurs, a code number defined in *Table 7.4* is displayed.

Troubleshooting

Cycle power

Check that the option is properly installed

Check for loose or missing wiring

WARNING 25, Brake resistor short circuit

The brake resistor is monitored during operation. If a short circuit occurs, the brake function is disabled and the warning appears. The adjustable frequency drive is still operational but without the brake function. Remove power to the adjustable frequency drive and replace the brake resistor (see *parameter 2-15 Brake Check*).

WARNING/ALARM 26, Brake resistor power limit

The power transmitted to the brake resistor is calculated as a mean value over the last 120 seconds of run time. The calculation is based on the intermediate circuit voltage and the brake resistance value set in *parameter 2-16 AC Brake Max. Current*. The warning is active when the dissipated braking energy is higher than 90% of the brake resistance power. If [2] *Trip* is selected in *parameter 2-13 Brake Power Monitoring*, the adjustable frequency drive trips when the dissipated braking energy reaches 100%.

WARNING/ALARM 27, Brake chopper fault

The brake transistor is monitored during operation and if a short circuit occurs, the brake function is disabled and a warning is issued. The adjustable frequency drive is still operational but, since the brake transistor has short-circuited, substantial power is transmitted to the brake resistor, even if it is inactive.

Remove power to the adjustable frequency drive and remove the brake resistor.

WARNING/ALARM 28, Brake check failed

The brake resistor is not connected or not working. Check *parameter 2-15 Brake Check*.

ALARM 29, Heatsink temp

The maximum temperature of the heatsink has been exceeded. The temperature fault will not reset until the temperature falls below a defined heatsink temperature. The trip and reset points are different based on the adjustable frequency drive power size.

Troubleshooting

Check for the following conditions.

Ambient temperature too high.

Motor cable too long.

It may be necessary to contact your Danfoss supplier or service department. Note the code number for further troubleshooting directions.

No.	Text
0	Serial port cannot be initialized. Contact your Danfoss supplier or Danfoss Service Department.
256-258	Power EEPROM data is defective or too old. Replace power card.
512-519	Internal fault. Contact your Danfoss supplier or Danfoss Service Department.
783	Parameter value outside of min/max limits
1024-1284	Internal fault. Contact your Danfoss supplier or the Danfoss Service Department.
1299	Option SW in slot A is too old
1300	Option SW in slot B is too old
1302	Option SW in slot C1 is too old
1315	Option SW in slot A is not supported (not allowed)
1316	Option SW in slot B is not supported (not allowed)
1318	Option SW in slot C1 is not supported (not allowed)
1379-2819	Internal fault. Contact your Danfoss supplier or Danfoss Service Department.
2561	Replace control card
2820	LCP stack overflow
2821	Serial port overflow
2822	USB port overflow
3072-5122	Parameter value is outside its limits
5123	Option in slot A: Hardware incompatible with control board hardware
5124	Option in slot B: Hardware incompatible with control board hardware
5125	Option in slot C0: Hardware incompatible with control board hardware
5126	Option in slot C1: Hardware incompatible with control board hardware
5376-6231	Internal fault. Contact your Danfoss supplier or Danfoss Service Department.

Table 7.4 Internal Fault Codes

ALARM 39, Heatsink sensor

No feedback from the heatsink temperature sensor.

The signal from the IGBT thermal sensor is not available on the power card. The problem could be on the power card, on the gate drive card, or the ribbon cable between the power card and gate drive card.

WARNING 40, Overload of digital output terminal 27

Check the load connected to terminal 27 or remove short-circuit connection. Check *parameter 5-00 Digital I/O Mode* and *parameter 5-01 Terminal 27 Mode*.

WARNING 41, Overload of digital output terminal 29

Check the load connected to terminal 29 or remove short-circuit connection. Check *parameter 5-00 Digital I/O Mode* and *parameter 5-02 Terminal 29 Mode*.

WARNING 42, Overload of digital output on X30/6 or overload of digital output on X30/7

For X30/6, check the load connected to X30/6 or remove the short-circuit connection. Check *parameter 5-32 Term X30/6 Digi Out (MCB 101)*.

For X30/7, check the load connected to X30/7 or remove the short-circuit connection. Check *parameter 5-33 Term X30/7 Digi Out (MCB 101)*.

ALARM 43, Ext. supply

MCB 113 Ext. Relay Option is mounted without ext. 24V DC. Either connect an ext. 24V DC supply or specify that no external supply is used via *parameter 14-80 Option Supplied by External 24VDC* [0]. A change in *parameter 14-80 Option Supplied by External 24VDC* requires a power cycle.

ALARM 45, Earth fault 2

Ground fault on start-up.

Troubleshooting

Check for proper grounding and loose connections.

Check for proper wire size.

Check motor cables for short-circuits or leakage currents.

ALARM 46, Power card supply

The supply on the power card is out of range.

There are three power supplies generated by the switch mode power supply (SMPS) on the power card: 24 V, 5 V, ±18 V. When powered with 24 V DC with the MCB 107 option, only the 24 V and 5 V supplies are monitored. When powered with three phase AC line voltage, all three supplies are monitored.

Troubleshooting

Check for a defective power card.

Check for a defective control card.

Check for a defective option card.

If a 24 V DC power supply is used, verify proper supply power.

WARNING 47, 24 V supply low

The 24 V DC is measured on the control card. The external 24 V DC backup power supply may be overloaded, otherwise contact the Danfoss supplier.

WARNING 48, 1.8 V supply low

The 1.8 V DC supply used on the control card is outside of allowable limits. The power supply is measured on the control card. Check for a defective control card. If an option card is present, check for an overvoltage condition.

WARNING 49, Speed limit

When the speed is not within the specified range in *parameter 4-11 Motor Speed Low Limit [RPM]* and *parameter 4-13 Motor Speed High Limit [RPM]*, the adjustable frequency drive shows a warning. When the speed is below the specified limit in *parameter 1-86 Trip Speed Low [RPM]* (except when starting or stopping), the adjustable frequency drive will trip.

ALARM 50, AMA calibration failed

Contact your Danfoss supplier or Danfoss Service Department.

ALARM 51, AMA check U_{nom} and I_{nom}

The settings for motor voltage, motor current and motor power are wrong. Check the settings in parameters 1-20 to 1-25.

ALARM 52, AMA low I_{nom}

The motor current is too low. Check the settings.

ALARM 53, AMA motor too big

The motor is too big for the AMA to operate.

ALARM 54, AMA motor too small

The motor is too small for the AMA to operate.

ALARM 55, AMA parameter out of range

The parameter values of the motor are outside of the acceptable range. AMA will not run.

ALARM 56, AMA interrupted by user

The user has interrupted the AMA.

ALARM 57, AMA internal fault

Try to restart AMA again. Repeated restarts can overheat the motor.

ALARM 58, AMA Internal fault

Contact your Danfoss supplier.

WARNING 59, Current limit

The current is higher than the value in *parameter 4-18 Current Limit*. Ensure that motor data in parameters 1-20 to 1-25 are set correctly. Possibly increase the current limit. Be sure that the system can operate safely at a higher limit.

WARNING 60, External interlock

A digital input signal is indicating a fault condition external to the frequency converter. An external interlock has commanded the frequency converter to trip. Clear the external fault condition. To resume normal operation, apply 24 V DC to the terminal programmed for external interlock. Reset the frequency converter.

WARNING/ALARM 61, Feedback error

An error between calculated speed and speed measurement from feedback device. The function Warning/Alarm/Disabling setting is in *parameter 4-30 Motor Feedback Loss Function*. Accepted error setting in *parameter 4-31 Motor Feedback Speed Error* and the allowed time the error occur setting in *parameter 4-32 Motor Feedback Loss Timeout*. During a commissioning procedure the function may be effective.

WARNING 62, Output frequency at maximum limit

The output frequency has reached the value set in *parameter 4-19 Max Output Frequency*. Check the application to determine the cause. Possibly increase the output frequency limit. Be sure the system can operate safely at a higher output frequency. The warning will clear when the output drops below the maximum limit.

ALARM 63, Mechanical brake low

The actual motor current has not exceeded the "release brake" current within the "Start delay" time window.

WARNING/ALARM 65, Control card over temperature

The cut-out temperature of the control card is 176 °F [80 °C].

Troubleshooting

- Check that the ambient operating temperature is within limits.
- Check for clogged filters.
- Check fan operation.
- Check the control card.

WARNING 66, Heatsink temperature low

The adjustable frequency drive is too cold to operate. This warning is based on the temperature sensor in the IGBT module.

Increase the ambient temperature of the unit. Also, a trickle amount of current can be supplied to the adjustable frequency drive whenever the motor is stopped by setting *parameter 2-00 DC Hold/Preheat Current* at 5% and *parameter 1-80 Function at Stop*.

ALARM 67, Option module configuration has changed

One or more options have either been added or removed since the last power-down. Check that the configuration change is intentional and reset the unit.

ALARM 68, Safe Stop activated

Loss of the 24 V DC signal on terminal 37 has caused the filter to trip. To resume normal operation, apply 24 V DC to terminal 37 and reset the filter.

ALARM 69, Power card temperature

The temperature sensor on the power card is either too hot or too cold.

Troubleshooting

Check that the ambient operating temperature is within limits.

Check for clogged filters.

Check fan operation.

Check the power card.

ALARM 70, Illegal FC configuration

The control card and power card are incompatible. Contact your supplier with the type code of the unit from the nameplate and the part numbers of the cards to check compatibility.

ALARM 71, PTC 1 safe stop

Safe Stop has been activated from the MCB 112 PTC Thermistor Card (motor too warm). Normal operation can be resumed when the MCB 112 applies 24 V DC to T-37 again (when the motor temperature reaches an acceptable level) and when the Digital Input from the MCB 112 is deactivated. When that happens, a reset signal must be sent (via Bus, Digital I/O, or by pressing [Reset]).

ALARM 72, Dangerous failure

Safe Stop with Trip Lock. The Dangerous Failure Alarm is issued if the combination of safe stop commands is unexpected. This is the case if VLT PTC Thermistor Card enables X44/10 but safe stop is somehow not enabled. Furthermore, if the MCB 112 is the only device using safe stop (specified through selection [4] or [5] in *parameter 5-19 Terminal 37 Safe Stop*), an unexpected combination is activation of safe stop without the X44/10 being activated. The following table summarizes the unexpected combinations that lead to Alarm 72.

NOTICE!

If X44/10 is activated in selection 2 or 3, this signal is ignored. However, the MCB 112 will still be able to activate Safe Stop.

WARNING 73, Safe stop auto restart

Safe stopped. With automatic restart enabled, the motor may start when the fault is cleared.

ALARM 74, PTC Thermistor

Alarm related to the ATEX option. The PTC is not working.

ALARM 75, Illegal profile sel.

Parameter value must not be written while motor is running. Stop motor before writing MCO profile to *parameter 8-10 Control Word Profile* for instance.

WARNING 76, Power unit setup

The required number of power units does not match the detected number of active power units.

Troubleshooting:

When replacing an F-frame module, this warning occurs, if the power-specific data in the module power card does

not match the rest of the frequency converter. Confirm the spare part and its power card are the correct part number.

WARNING 77, Reduced power mode

This warning indicates that the frequency converter is operating in reduced power mode (i.e. less than the allowed number of inverter sections). This warning is generated on power cycle when the frequency converter is set to run with fewer inverters, and remains on.

ALARM 78, Tracking error

The difference between set point value and actual value has exceeded the value in *parameter 4-35 Tracking Error*. Disable the function by *parameter 4-34 Tracking Error Function* or select an alarm/warning also in *parameter 4-34 Tracking Error Function*. Investigate the mechanics around the load and motor, Check feedback connections from motor – encoder – to frequency converter. Select motor feedback function in *parameter 4-30 Motor Feedback Loss Function*. Adjust tracking error band in *parameter 4-35 Tracking Error* and *parameter 4-37 Tracking Error Ramping*.

ALARM 79, Illegal power section configuration

The scaling card is the incorrect part number or not installed. Also MK102 connector on the power card could not be installed.

ALARM 80, Drive initialized to default value

Parameter settings are initialized to default settings after a manual reset. Reset the unit to clear the alarm.

ALARM 81, CSIV corrupt

CSIV file has syntax errors.

ALARM 82, CSIV parameter error

CSIV failed to init a parameter.

ALARM 83, Illegal option combination

The mounted options are not supported to work together.

ALARM 84, No safety option

The safety option was removed without applying a general reset. Reconnect the safety option.

ALARM 88, Option detection

A change in the option layout has been detected. This alarm occurs when *parameter 14-89 Option Detection* is set to [0] *Frozen configuration* and the option layout for some reason has changed. An option layout change has to be enabled in *parameter 14-89 Option Detection* before the change is accepted. If the change of configuration is not accepted, it is only possible to reset Alarm 88 (Trip-lock) when the option configuration has been re-established/corrected.

WARNING 89, Mechanical brake sliding

The hoist brake monitor has detected a motor speed > 10 RPM.

ALARM 90, Feedback monitor

Check the connection to encoder/resolver option and eventually replace the MCB 102 or MCB 103.

ALARM 91, Analog input 54 wrong settings

Switch S202 has to be set in position OFF (voltage input) when a KTY sensor is connected to analog input terminal 54.

WARNING/ALARM 104, Mixing fan fault

The fan monitor checks that the fan is spinning at power-up or whenever the mixing fan is turned on. If the fan is not operating, then the fault is annunciated. The mixing-fan fault can be configured as a warning or an alarm trip by *parameter 14-53 Fan Monitor*.

Troubleshooting

Cycle power to the frequency converter to determine if the warning/alarm returns.

WARNING 163, ATEX ETR cur.lim.warning

The frequency converter has run above the characteristic curve for more than 50 s. The warning is activated at 83% and de-activated at 65% of the permitted thermal overload.

ALARM 164, ATEX ETR cur.lim.alarm

Operating above the characteristic curve for more than 60 s within a period of 600 s activates the alarm and the frequency converter trips.

WARNING 165, ATEX ETR freq.lim.warning

The frequency converter is running more than 50 s below the permitted minimum frequency (*parameter 1-98 ATEX ETR interpol. points freq. [0]*).

ALARM 166, ATEX ETR freq.lim.alarm

The frequency converter has operated more than 60 s (in a period of 600 s) below the permitted minimum frequency (*parameter 1-98 ATEX ETR interpol. points freq. [0]*).

ALARM 246, Power card supply

This alarm is only for F Frame frequency converters. It is equivalent to Alarm 46. The report value in the alarm log indicates which power module generated the alarm:

- 1 = left most inverter module.
- 2 = middle inverter module in F2 or F4 frequency converter.
- 2 = right inverter module in F1 or F3 frequency converter.
- 3 = right inverter module in F2 or F4 frequency converter.
- 5 = rectifier module.

WARNING 250, New spare part

A component in the adjustable frequency drive has been replaced. Reset the adjustable frequency drive for normal operation.

WARNING 251, New typecode

The power card or other components have been replaced and the type code changed. Reset to remove the warning and resume normal operation.

8 General Specifications

8.1.1 Mains Supply 3x200-240 V AC

	P15K	P18K	P22K
High/Normal Load ¹⁾	NO	NO	NO
Typical Shaft Output [HP/kW]	25/18.5	30/22	40/30
Enclosure IP20	B4	C3	C3
Enclosure IP21, IP55, IP66	C1	C1	C1
Output current			
Continuous (3 x 200-240 V) [A]	74.8	88	115
Intermittent (60 s overload) (3 x 200-240 V) [A]	82.3	96.8	127
Continuous kVA (208 V AC) [kVA]	26.9	31.7	41.4
Max. input current			
Continuous (3 x 200-240 V) [A]	68	80	104
Intermittent (60 s overload) (3 x 200-240 V) [A]	74.8	88	114
Additional specifications			
IP20 max. cable cross-section ⁵⁾ (mains, brake, motor and load sharing)	35 (2)	50 (1)	50 (1)
IP21, IP55, IP66 max. cable cross-section ⁵⁾ (mains, motor, load sharing) [mm ² (AWG)] ²⁾	50 (1)	50 (1)	50 (1)
Max cable size with mains disconnect [mm ² (AWG)] ²⁾	50, 35, 35 (1, 2, 2)		
Estimated power loss at rated max. load [W] ⁴⁾	737	845	1140
Weight, IP20 [lbs/kg]	51.8/23.5	110/50	110/50
Weight, IP21, IP55/IP66 [lbs/kg]	99.2/45	99.2/45	99.2/45
Efficiency ⁴⁾	0.96	0.97	0.97

Table 8.1 Mains Supply 3x200-240 V AC

For fuse ratings, see chapter 3.4.1 Fuses

1) Normal overload = 110% torque during 60 s.

2) American Wire Gauge.

3) Measured using 5 m screened motor cables at rated load and rated frequency.

4) The typical power loss is at nominal load conditions and expected to be within $\pm 15\%$ (tolerance relates to variety in voltage and cable conditions).

Values are based on a typical motor efficiency (eff2/eff3 border line). Motors with lower efficiency will also add to the power loss in the frequency converter and opposite.

If the switching frequency is increased compared to the default setting, the power losses may rise significantly.

LCP and typical control card power consumptions are included. Further options and customer load may add up to 30 W to the losses. (Though typical only 4 W extra for a fully loaded control card, or options for slot A or slot B, each).

Although measurements are made with state of the art equipment, some measurement inaccuracy must be allowed for ($\pm 5\%$).

5) The three values for the max. cable cross section are for single core, flexible wire and flexible wire with sleeve, respectively.

8.1.2 Mains Supply 3x380-480 V AC

	P15K	P18K	P22K
High/Normal Load ¹⁾	NO	NO	NO
Typical shaft output [HP/kW]	25/18.5	30/22	40/30
Enclosure IP20	B3	B4	B4
Enclosure IP21, IP55, IP66	B1	B2	B2
Output current			
Continuous (3 x 380-440 V) [A]	37.5	44	61
Intermittent (60 s overload) (3 x 380-440 V) [A]	41.3	48.4	67.1
Continuous (3 x 441-500 V) [A]	34	40	52
Intermittent (60 s overload) (3 x 441-500 V) [A]	37.4	44	57.2
Continuous kVA (400 V AC) [kVA]	26	30.5	42.3
Continuous kVA (460 V AC) [kVA]	27.1	31.9	41.4
Max. input current			
Continuous (3 x 380-440 V) [A]	34	40	55
Intermittent (60 s overload) (3 x 380-440 V) [A]	37.4	44	60.5
Continuous (3 x 441-500 V) [A]	31	36	47
Intermittent (60 s overload) (3 x 441-500 V) [A]	34.1	39.6	51.7
Additional specifications			
IP21, IP55, IP66 max. cable cross-section ⁵⁾ (mains, brake, load sharing) [mm ² (AWG)] ²⁾	16, 10, 16 (6, 8, 6)	35,-,-(2,-,-)	35,-,-(2,-,-)
IP21, IP55, IP66 max. cable cross-section ⁵⁾ (motor) [mm ² (AWG)] ²⁾	10, 10,- (8, 8,-)	35, 25, 25 (2, 4, 4)	35, 25, 25 (2, 4, 4)
IP20 max. cable cross-section ⁵⁾ (mains, brake, motor and load sharing)	10, 10,- (8, 8,-)	35,-,-(2,-,-)	35,-,-(2,-,-)
Estimated power loss at rated max. load [W] ⁴⁾	465	525	739
Weight, enclosure IP20 [lbs/kg]	26.46/12	51.8/23.5	51.8/23.5
Weight, enclosure IP21, IP55, IP66 [lbs/kg]	50.4/23	59.5/27	59.5/27
Efficiency ⁴⁾	0.98	0.98	0.98

Table 8.2 Mains Supply 3x380-480 V AC

For fuse ratings, see chapter 3.4.1 Fuses

1) Normal overload = 110% torque during 60 s.

2) American Wire Gauge.

3) Measured using 5 m screened motor cables at rated load and rated frequency.

 4) The typical power loss is at nominal load conditions and expected to be within $\pm 15\%$ (tolerance relates to variety in voltage and cable conditions).

Values are based on a typical motor efficiency (eff2/eff3 border line). Motors with lower efficiency will also add to the power loss in the frequency converter and vice versa.

If the switching frequency is increased compared to the default setting, the power losses may rise significantly.

LCP and typical control card power consumptions are included. Further options and customer load may add up to 30 W to the losses. (Though typical only 4 W extra for a fully loaded control card, or options for slot A or slot B, each).

 Although measurements are made with state of the art equipment, some measurement inaccuracy must be allowed for ($\pm 5\%$).

5) The three values for the max. cable cross section are for single core, flexible wire and flexible wire with sleeve, respectively.

8.1.3 Mains Supply 3x525-600 V AC

	P15K	P18K	P22K
High/Normal Load ¹⁾	NO	NO	NO
Typical Shaft Output [HP/kW]	25/18.5	30/22	40/30
Enclosure IP21, IP55, IP66	B1	B2	B2
Enclosure IP20	B3	B4	B4
Output current			
Continuous (3 x 525-550 V) [A]	28	36	43
Intermittent (3 x 525-550 V) [A]	31	40	47
Continuous (3 x 525-600 V) [A]	27	34	41
Intermittent (3 x 525-600 V) [A]	30	37	45
Continuous kVA (550 V AC) [kVA]	26.7	34.3	41.0
Continuous kVA (575 V AC) [kVA]	26.9	33.9	40.8
Max. input current			
Continuous at 550 V [A]	25.4	32.7	39
Intermittent at 550 V [A]	28	36	43
Continuous at 575 V [A]	24	31	37
Intermittent at 575 V [A]	27	34	41
Additional specifications			
IP21, IP55, IP66 max. cable cross-section ⁵⁾ (mains, brake, load sharing) [mm ² (AWG)] ²⁾	16, 10, 10 (6, 8, 8)	35,-,-(2,-,-)	35,-,-(2,-,-)
IP21, IP55, IP66 max. cable cross-section ⁵⁾ (motor) [mm ² (AWG)] ²⁾	10, 10,- (8, 8,-)	35, 25, 25 (2, 4, 4)	35, 25, 25 (2, 4, 4)
IP20 max. cable cross-section ⁵⁾ (mains, brake, motor and load sharing)	10, 10,- (8, 8,-)	35,-,-(2,-,-)	35,-,-(2,-,-)
Estimated power loss at rated max. load [W] ⁴⁾	285	329	700
Weight, enclosure IP21, IP55, IP66 [lbs/kg]	50.4/23	59.5/27	59.5/27
Weight, enclosure IP20 [lbs/kg]	26.46/12	51.8/23.5	51.8/23.5
Efficiency ⁴⁾	0.98	0.98	0.98

Table 8.3 Mains Supply 3x525-600 V AC

Mains Supply (L1, L2, L3)

Supply voltage	200-240 V ±10%
Supply voltage	380-480 V ±10%
Supply voltage	525-600 V ±10%
Supply frequency	50/60 Hz
Max. imbalance temporary between mains phases	3.0 % of rated supply voltage
True Power Factor (λ)	≥ 0.9 nominal at rated load
Displacement Power Factor ($\cos \varphi$) near unity	(> 0.98)
Switching on input supply L1, L2, L3 (power-ups) ≤ 7.5 kW	Max. 2 times/min.
Switching on input supply L1, L2, L3 (power-ups) ≥ 11 kW	Max. 1 time/min.
Environment according to EN60664-1	Overvoltage category III/pollution degree 2

The unit is suitable for use on a circuit capable of delivering not more than 100.000 RMS symmetrical Amperes, 240/500/600 V maximum

Motor Compressor Output (U, V, W)

Output voltage	0-100% of supply voltage
Switching on output	See <i>parameter 14-01 Switching Frequency</i>

Cable lengths and cross sections

Max. motor cable length, screened/armored	150 m
Max. motor cable length, unscreened/unarmored	300 m
Max. cross section to motor, mains, load sharing and brake *	
Maximum cross section to control terminals, rigid wire	1.5 mm ² /16 AWG (2 x 0.75 mm ²)
Maximum cross section to control terminals, flexible cable	1 mm ² /18 AWG
Maximum cross section to control terminals, cable with enclosed core	0.5 mm ² /20 AWG
Minimum cross section to control terminals	0.25 mm ²

* See *Table 8.1, Table 8.2 and Table 8.3 for more information!*

Digital Inputs

Voltage level	0 - 24 V DC
Voltage level, logic.0. PNP	< 5 V DC
Voltage level, logic.1. PNP	> 10 V DC
Voltage level, logic .0. NPN2)	> 19 V DC
Voltage level, logic .1. NPN2)	< 14 V DC
Maximum voltage on input	28 V DC
Input resistance, Ri	approx. 4 kΩ

Safe Stop Terminal 37

Voltage level	0 - 24 V DC
Voltage level, logic.0. PNP	< 4 V DC
Voltage level, logic.1. PNP	>20 V DC
Nominal input current at 24 V	50 mA _{rms}
Nominal input current at 20 V	60 mA _{rms}
Input capacitance	400 nF

Terminal 37 is fixed PNP logic

All digital inputs are galvanically isolated from the supply voltage (PELV) and other high-voltage terminals.

1. Terminals 27 and 29 can also be programmed as output.
2. Except safe stop input Terminal 37.
3. Terminal 37 can only be used as safe stop input.

Terminal 37 is suitable for category 3 installations according to EN 954-1 (safe stop according to category 0 EN 60204-1) as required by the EU Machinery Directive 98/37/EC. Terminal 37 and the Safe Stop function are designed in conformance with EN 60204-1, EN 50178, EN 61800-2, EN 61800-3, and EN 954-1. For correct and safe use of the Safe Stop function follow the related information and instructions in the Application Guidelines.

Analog Inputs

Number of analog inputs	2
Terminal number	53, 54
Modes	Voltage or current
Mode select	Switch S201 and switch S202
Voltage mode	Switch S201/switch S202 = OFF (U)
Voltage level	-10 to +10 V (scaleable)
Input resistance, Ri: approx	10 k Ω
Max. voltage	\pm 20 V
Current mode	Switch S201/switch S202 = ON (I)
Current level	0/4 to 20 mA (scaleable)
Input resistance, Ri	approx. 200 Ω
Max. current	30 mA
Resolution for analog inputs	10 bit (+ sign)
Accuracy of analog inputs	Max. error 0.5% of full scale
Bandwidth	100 Hz

The analog inputs are galvanically isolated from the supply voltage (PELV) and other high-voltage terminals.

Digital Output

Programmable digital/pulse outputs	2
Terminal number	27, 29 ¹⁾
Voltage level at digital/frequency output	0-24 V
Max. output current (sink or source)	40 mA
Max. load at frequency output	1 k Ω
Max. capacitive load at frequency output	10 nF
Minimum output frequency at frequency output	0 Hz
Maximum output frequency at frequency output	32 kHz
Accuracy of frequency output	Max. error: 0.1 % of full scale
Resolution of frequency outputs	12 bit

¹⁾ Terminal 27 and 29 can also be programmed as input. The digital output is galvanically isolated from the supply voltage (PELV) and other high-voltage terminals.

Analog Output

Number of programmable analog outputs	1
Terminal number	42
Current range at analog output	0/4 to 20 mA
Max. load to common at analog output	500 Ω
Accuracy on analog output	Max. error: 0.5 % of full scale
Resolution on analog output	12 bit

The analog output is galvanically isolated from the supply voltage (PELV) and other high-voltage terminals

Control Card, 24 V DC Output

Terminal number	12, 13
Max. load	200 mA

The 24 V DC supply is galvanically isolated from the supply voltage (PELV), but has the same potential as the analog and digital inputs and outputs.

Control Card, 10 V DC Output

Terminal number	50
Output voltage	10.5 V ± 0.5 V
Max. load	15 mA

The 10 V DC supply is galvanically isolated from the supply voltage (PELV) and other high-voltage terminals

Control Card, RS-485 Serial Communication

Terminal number	68 (PTX+, RX+), 69 (N, TX-, RX-)
Terminal number 61	Common for terminals 68 and 69

The RS-485 serial communication circuit is functionally separated from other central circuits and galvanically isolated from the supplier voltage (PELV).

Control Card, USB Serial Communication

USB standard	1.1 (Full speed)
USB plug	USB type B device plug

Connection to PC is carried out via a standard host/device USB cable.

The USB connection is galvanically isolated from the supply voltage (PELV) and other high-voltage terminals. The USB ground connection is not galvanically isolated from protection ground. Use only isolated laptop as PC connection to the USB connector on the frequency converter drive

Relay Outputs

Programmable relay outputs	2
Relay 01 Terminal number	1-3 (break), 1-2 (make)
Max. terminal load (AC-1)1) on 1-3 (NC), 1-2 (NO) (Resistive load)	240 V AC, 2 A
Max. terminal load (AC-15)1) (Inductive load @ cosφ 0.4)	240 V AC, 0.2 A
Max. terminal load (DC-1)1) on 1-2 (NO), 1-3 (NC) (Resistive load)	60 V DC, 1 A
Max. terminal load (DC-13)1) (Inductive load)	24 V DC, 0.1 A
Relay 02 (CDS 302 only) Terminal number	4-6 (break), 4-5 (make)
Max. terminal load (AC-1)1) on 4-5 (NO) (Resistive load)	400 V AC, 2 A
Max. terminal load (AC-15)1) on 4-5 (NO) (Inductive load @ cosφ 0.4)	240 V AC, 0.2 A
Max. terminal load (DC-1)1) on 4-5 (NO) (Resistive load)	80 V DC, 2 A

Surroundings

Enclosure ≤ enclosure type A	IP20, IP55
Enclosure ≥ enclosure type A, B	IP21, IP55
Enclosure kit available ≤ enclosure type A	IP21/TYPE 1/IP 4X top
Vibration test	1.0 g
Max. relative humidity	5% - 95% (IEC 721-3-3; Class 3K3 (non-condensing) during operation)
Aggressive environment (IEC 721-3-3), uncoated	class 3C2
Aggressive environment (IEC 721-3-3), coated	class 3C3
Test method according to IEC 60068-2-43 H2S (10 days)	
Ambient temperature	Max. 122 °F/50 °C
<i>Derating for high ambient temperature, see section on special conditions</i>	
Minimum ambient temperature during full-scale operation	32 °F/0 °C
Minimum ambient temperature at reduced performance	14 °F/-10 °C
Temperature during storage/transport	-13 to 149 °F/-25 to +65/70 °C
Maximum altitude above sea level without derating	3280 ft/1000 m
Maximum altitude above sea level with derating	9842 ft/3000 m
<i>Derating for high altitude, see section on special conditions</i>	
EMC standards, Emission	EN 61800-3, EN 61000-6-3/4, EN 55011, IEC 61800-3 EN 61800-3, EN 61000-6-1/2,
EMC standards, Immunity	EN 61000-4-2, EN 61000-4-3, EN 61000-4-4, EN 61000-4-5, EN 61000-4-6

Index

A

Access to Control Terminals..... 21
 Accessory bag..... 22, 24, 37
 Accessory Bag..... 14
 Adjustable Warnings, 4-5*..... 59
 Alarm Messages..... 147
 AMA..... 154, 158
 Ambient Temperature and Altitude..... 14
 Analog input..... 72, 153
 Analog inputs..... 165
 Analog outputs..... 166
 Analog signal..... 153

B

Braking..... 156
 Branch Circuit Protection..... 29

C

Cable entry..... 17
 Cable lengths and cross sections..... 164
 Catch up..... 64
 Communication option..... 156
 Comparators, 13-1*..... 88
 Conductors..... 21
 Configuration..... 81
 Control cables..... 24, 25, 26
 Control card..... 102, 153
 Control Card..... 103, 166
 Control terminal..... 164
 Control terminals..... 42
 Ctrl. Word Settings, 8-1*..... 82
 Current rating..... 154

D

Data Readouts, 16-**..... 106
 DC link..... 6, 153
 Decoupling plate..... 20, 24
 Default settings..... 6, 23, 42, 103
 Default Settings..... 127
 Diagnosis Read-Outs, 16-9*..... 110
 Digital input..... 62, 102, 118, 121, 154, 166

Digital inputs..... 42, 54, 67
 Digital Inputs..... 164
 Digital output..... 62, 102
 Digital Outputs..... 66
 Digital/Bus, 8-5*..... 83

E

ETR..... 107

F

FC Port Diagnostics, 8-8*..... 84
 FC Port Settings, 8-3*..... 82
 Feedback..... 157
 Fieldbus & FC Port, 16-8*..... 110
 Fuses..... 29, 156

G

General Settings, 8-0*..... 81
 General Status, 16-0*..... 106
 Graphical display..... 40
 Graphical Display..... 43
 Ground leakage current..... 7, 28

I

Input terminal..... 153
 Inputs and Outputs..... 109
 Intermediate circuit..... 7

K

Keypad..... 7
 Knockouts..... 17

L

LCP..... 7, 37, 42, 43, 49, 50, 51, 103, 114, 122, 125
 Leakage current..... 20, 21, 28
 Leakage Current..... 7
 Local reference..... 47
 Logic Rules, 13-4*..... 94

M

Mains Connection for B1, B2 and B3..... 1
 Mains connection for B4, C1 and C3..... 1
 Mains supply..... 7, 24, 42, 102
 Mains Supply..... 161, 164

Index	Operating Instructions
MCT 10.....	42
Mechanical Dimensions.....	16
Mechanical Mounting.....	15
Motor compressor cable.....	20
Motor Compressor Connection.....	20
Motor connection.....	7
Motor current.....	66, 124, 125, 158
Motor Current.....	50
Motor data.....	154, 158
Motor Limits, 4-1*.....	59
Motor overload protection.....	6
Motor power.....	158
Motor Status.....	106
O	
Operating mode.....	47
Output current.....	154
P	
Phase loss.....	153
Programming.....	153
R	
Ramp up time.....	55
Relay outputs.....	66
Relay Outputs.....	166
Reset.....	154, 159
RS Flip Flops, 13-1*.....	91
S	
Safe stop.....	37
Safe Stop.....	24, 164
Safe Torque Off.....	7
Safety Instructions.....	6
Screened/armored.....	20, 26, 164
Sequence of Operation.....	5
Shielded/armoured.....	24, 25
Short circuit.....	155
Short Circuit Protection.....	29
Speed Bypass, 4-6*.....	60
States, 13-5*.....	98
Stripping.....	22
Supply voltage.....	156
Surroundings.....	167
T	
Terminal 54.....	160
Thermal load.....	107
Timers, 13-2*.....	94
V	
Voltage imbalance.....	153
Voltage level.....	7, 164, 165
W	
Warnings.....	147



Danfoss Drives

4401 N. Bell School Rd.
Loves Park IL 61111 USA
Phone: 1-800-432-6367
1-815-639-8600
Fax: 1-815-639-8000
www.danfossdrives.com

Danfoss Drives

8800 W. Bradley Rd.
Milwaukee, WI 53224 USA
Phone: 1-800-621-8806
1-414-355-8800
Fax: 1-414-355-6117
www.danfossdrives.com

.....
Danfoss shall not be responsible for any errors in catalogs, brochures or other printed material. Danfoss reserves the right to alter its products at any time without notice, provided that alterations to products already on order shall not require material changes in specifications previously agreed upon by Danfoss and the Purchaser. All trademarks in this material are property of the respective companies. Danfoss and the Danfoss logotype are trademarks of Danfoss A/S. All rights reserved.
.....

Danfoss A/S
Ulsnaes 1
DK-6300 Graasten
vlt-drives.danfoss.com

