

Contents

<b>1 How to Read these Operating Instructions</b>	<b>3</b>
1.1.2 Abbreviations	4
<b>2 Safety Instructions and General Warning</b>	<b>5</b>
2.1.1 High Voltage	5
2.1.2 Safety Instructions	5
2.1.5 Avoid Unintended Start	6
2.1.6 Safe Stop	6
2.1.8 IT Mains	7
<b>3 How to Install</b>	<b>8</b>
3.1 Pre-installation	8
3.1.1 Planning the Installation Site	8
3.1.2 Receiving the Frequency Converter	8
3.1.3 Transportation and Unpacking	8
3.1.4 Lifting	8
3.1.5 Mechanical Dimensions	10
3.2 Mechanical Installation	15
3.2.3 Terminal Locations, F8-F14 - 12-Pulse	16
3.2.4 Cooling and Airflow	23
3.3 Field Installation of Options	26
3.3 Electrical Installation	27
3.3.1 Transformer Selection	27
3.3.2 Power Connections 12-Pulse Drives	27
3.3.7 Shielded Cables	39
3.3.11 Mains Connection	40
3.3.13 Fuses	42
3.3.16 Motor Bearing Currents	45
3.3.18 Control Cable Routing	46
3.3.20 Electrical Installation, Control Terminals	46
3.4 Connection Examples	48
3.4.1 Start/Stop	48
3.4.2 Pulse Start/Stop	48
3.5.1 Electrical Installation, Control Cables	49
3.5.2 Switches S201, S202, and S801	52
3.6 Final Set-Up and Test	52
3.7 Additional Connections	53
3.7.1 Mechanical Brake Control	53
3.7.3 Motor Thermal Protection	54

<b>4 How to Programme</b>	55
4.1.1 How to Programme on the Graphical LCP	55
4.2 Quick Setup	57
4.3 Parameter Lists	60
<b>5 General Specifications</b>	94
<b>6 Warnings and Alarms</b>	104
6.1 Warning and Alarm Definitions	104
<b>Index</b>	112

# 1 How to Read these Operating Instructions

The frequency converter is designed to provide high shaft performance on electrical motors. Please read this manual carefully for proper use. Incorrect handling of the frequency converter may cause improper operation of the frequency converter or related equipment, shorten lifetime or cause other troubles.

These Operating Instructions will help you get started, install, program, and troubleshoot your frequency converter.

Chapter 1, **How to Read these Operating Instructions**, introduces the manual and informs you about the approvals, symbols, and abbreviations used in this literature.

Chapter 2, **Safety Instructions and General Warnings**, entails instructions on how to handle the frequency converter correctly.

Chapter 3, **How to Install**, guides through mechanical and technical installation.

Chapter 4, **How to Programme**, shows how to operate and programme the frequency converter via the LCP.

Chapter 5, **General Specifications**, contains technical data about the frequency converter.

Chapter 6, **Warnings and Alarms**, assists in solving problems that may occur when using the frequency converter.

## Available literature

- The *VLT AutomationDrive Operating Instructions - High Power, MG33UXYY* provide the necessary information for getting the frequency converter up and running.
- The *VLT AutomationDrive Design Guide MG33BXY* entails all technical information about the frequency converter and customer design and applications.
- The *VLT AutomationDrive Programming Guide MG33MXY* provides information on how to programme and includes complete parameter descriptions.
- The *VLT AutomationDrive Profibus Operating Instructions MG33CXY* provide the information required for controlling, monitoring and programming the frequency converter via a Profibus fieldbus.

- The *VLT AutomationDrive DeviceNet Operating Instructions MG33DXY* provide the information required for controlling, monitoring and programming the frequency converter via a DeviceNet fieldbus.

X = Revision number

YY = Language code

Danfoss technical literature is also available online at [www.danfoss.com/drives](http://www.danfoss.com/drives).

## Symbols

The following symbols are used in this manual.



Indicates a potentially hazardous situation which, if not avoided, could result in death or serious injury.



Indicates a potentially hazardous situation which, if not avoided, may result in minor or moderate injury. It may also be used to alert against unsafe practices.

## CAUTION

Indicates a situation that may result in equipment or property-damage-only accidents.

## NOTE

Indicates highlighted information that should be regarded with attention to avoid mistakes or operate equipment at less than optimal performance.

## Approvals



### 1.1.1 Disposal Instruction

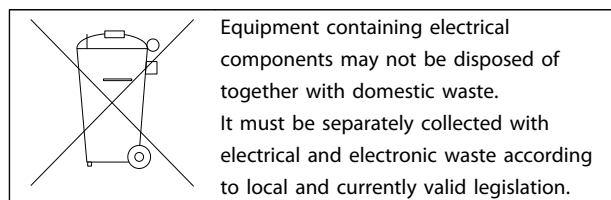

## 1.1.2 Abbreviations

Alternating current	AC
American wire gauge	AWG
Ampere/AMP	A
Automatic Motor Adaptation	AMA
Current limit	$I_{LIM}$
Degrees Celsius	°C
Direct current	DC
Drive Dependent	D-TYPE
Electro Magnetic Compatibility	EMC
Electronic Thermal Relay	ETR
Frequency converter	FC
Gram	g
Hertz	Hz
Horsepower	hp
Kilohertz	kHz
Local Control Panel	LCP
Meter	m
Millihenry Inductance	mH
Milliampere	mA
Millisecond	ms
Minute	min
Motion Control Tool	MCT
Nanofarad	nF
Newton Meters	Nm
Nominal motor current	$I_{M,N}$
Nominal motor frequency	$f_{M,N}$
Nominal motor power	$P_{M,N}$
Nominal motor voltage	$U_{M,N}$
Permanent Magnet motor	PM motor
Protective Extra Low Voltage	PELV
Printed Circuit Board	PCB
Rated Inverter Output Current	$I_{INV}$
Revolutions Per Minute	RPM
Regenerative terminals	Regen
Second	sec.
Synchronous Motor Speed	$n_s$
Torque limit	$T_{LIM}$
Volts	V
The maximum output current	$I_{VLT,MAX}$
The rated output current supplied by the frequency converter	$I_{VLT,N}$

## 2 Safety Instructions and General Warning

### ⚠ CAUTION

The frequency converter DC link capacitors remain charged after power has been disconnected. To avoid electrical shock hazard, disconnect the frequency converter from the mains before carrying out maintenance. Before doing service on the frequency converter wait at least the amount of time indicated below:

380-500 V	250-800 kW	40 minutes
525-690 V	355-1400 kW	30 minutes

VLT AutomationDrive  
Operating Instructions  
Software version: 6.5x

These Operating Instructions can be used for all VLT AutomationDrive frequency converters with software version 6.5x.

The software version number can be seen from *15-43 Software Version*.

### 2.1.1 High Voltage

#### ⚠ WARNING

The voltage of the frequency converter is dangerous whenever the frequency converter is connected to mains. Incorrect installation or operation of the motor or frequency converter may cause damage to the equipment, serious personal injury or death. The instructions in this manual must consequently be observed, as well as applicable local and national rules and safety regulations.

#### ⚠ WARNING

Installation in high altitudes

380-500 V: At altitudes above 3 km, please contact Danfoss regarding PELV.

525-690 V: At altitudes above 2 km, please contact Danfoss regarding PELV.

### 2.1.2 Safety Instructions

- Make sure the frequency converter is properly connected to earth.
- Protect users against supply voltage.
- Protect the motor against overloading according to national and local regulations.
- Motor overload protection is not included in the default settings. To add this function, set *1-90 Motor Thermal Protection* to value *ETR trip* or

*ETR warning.* For the North American market: ETR functions provide class 20 motor overload protection, in accordance with NEC.

- The earth leakage current exceeds 3.5 mA.
- The [Off] key is not a safety switch. It does not disconnect the frequency converter from mains.

### 2.1.3 General Warning

#### ⚠ WARNING

Touching the electrical parts may be fatal - even after the equipment has been disconnected from mains.

Also make sure that other voltage inputs have been disconnected, such as load-sharing (linkage of DC intermediate circuit), as well as the motor connection for kinetic back-up.

When using the frequency converter: wait at least 40 minutes.

Shorter time is allowed only if indicated on the nameplate for the specific unit.

#### ⚠ CAUTION

The earth leakage current from the frequency converter exceeds 3.5 mA. To ensure that the earth cable has a good mechanical connection to the earth connection (terminal 95), the cable cross section must be at least 10 mm<sup>2</sup> or 2 rated earth wires terminated separately. For proper earthing for EMC, see *3.3.3 Earthing*.

Residual Current Device

This product can cause a D.C. current in the protective conductor. Where a residual current device (RCD) is used for extra protection, only an RCD of Type B (time delayed) shall be used on the supply side of this product. See also *RCD Application Note MN90GX02* (x=version number).

Protective earthing of the frequency converter and the use of RCDs must always follow national and local regulations.

### 2.1.4 Before Commencing Repair Work

1. Disconnect the frequency converter from mains
2. Disconnect DC bus terminals 88 and 89 from load share applications
3. Wait for discharge of the DC-link. See period of time on the warning label
4. Remove motor cable

### 2.1.5 Avoid Unintended Start

While the frequency converter is connected to mains, the motor can be started/stopped using digital commands, bus commands, references or via the Local Control Panel (LCP):

- Disconnect the frequency converter from mains whenever personal safety considerations make it necessary to avoid unintended start.
- To avoid unintended start, always activate the [Off] key before changing parameters.
- An electronic fault, temporary overload, a fault in the mains supply, or lost motor connection may cause a stopped motor to start. The frequency converter with Safe Stop provides protection against unintended start, if the Safe Stop Terminal 37 is deactivated or disconnected.

### 2.1.6 Safe Stop

The FC 302 can perform the safety function *Safe Torque Off* (As defined by draft CD IEC 61800-5-2) or *Stop Category 0* (as defined in EN 60204-1).

It is designed and approved suitable for the requirements of Safety Category 3 in EN 954-1. This functionality is called Safe Stop. Before integrating and using Safe Stop in an installation, a thorough risk analysis on the installation must be carried out in order to determine whether the Safe Stop functionality and safety category are appropriate and sufficient. In order to install and use the Safe Stop function in accordance with the requirements of Safety Category 3 in EN 954-1, the related information and instructions of the *FC 300 Design Guide MG33BXYY* must be followed. The information and instructions of the Operating Instructions are not sufficient for a correct and safe use of the Safe Stop functionality.

### 2.1.7 Safe Stop Installation

To carry out an installation of a Category 0 Stop (EN60204) in conformity with Safety Category 3 (EN954-1), follow these instructions:

1. The bridge (jumper) between Terminal 37 and 24 V DC must be removed. Cutting or breaking the jumper is not sufficient. Remove it entirely to avoid short-circuiting. See jumper in *Illustration 2.1*.
2. Connect terminal 37 to 24 V DC by a short-circuit protected cable. The 24 V DC voltage supply must be interruptible by an EN954-1 Category 3 circuit interrupt device. If the interrupt device and the frequency converter are placed in the same installation panel, use an unscreened cable instead of a screened one.

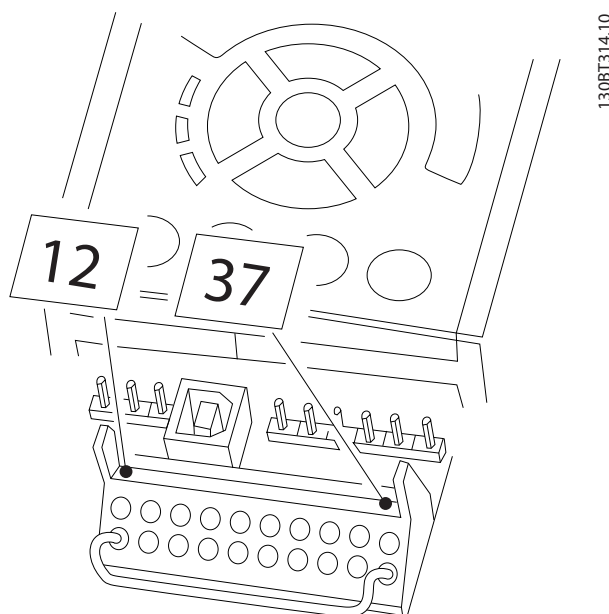

130BT314.10

Illustration 2.1 Bridge jumper between terminal 37 and 24 V DC

*Illustration 2.2* shows a Stopping Category 0 (EN 60204-1) with safety Category 3 (EN 954-1). The circuit interrupt is caused by an opening door contact. The illustration also shows how to connect a non-safety related hardware coast.

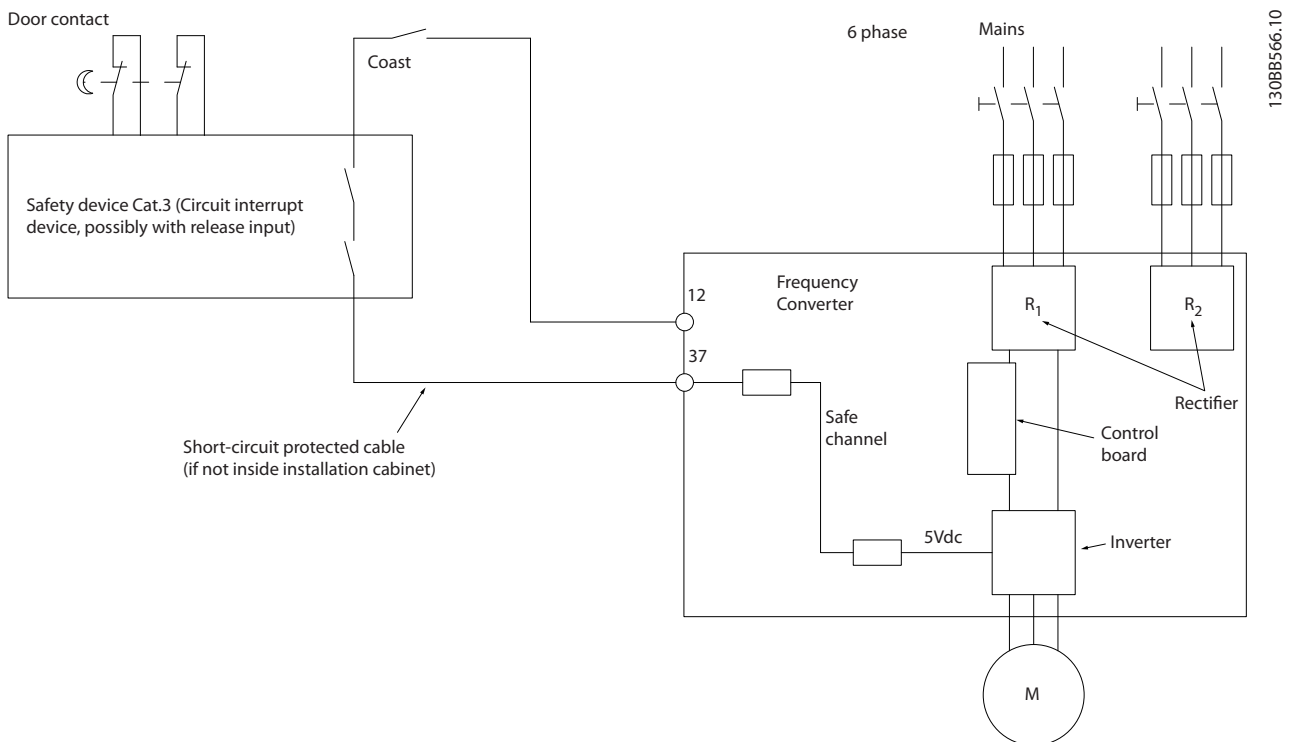

Illustration 2.2 Essential aspects of an installation to achieve a Stopping Category 0 (EN 60204-1) with safety Category 3 (EN 954-1).

## 2.1.8 IT Mains

14-50 RFI Filter can be used to disconnect the internal RFI capacitors from the RFI filter to ground in the 380 - 500V frequency converters. If this is done it will reduce the RFI performance to A2 level. For the 525 - 690V frequency converters, 14-50 RFI Filter has no function. The RFI switch cannot be opened.

### 3 How to Install

## 3

#### 3.1 Pre-installation

##### 3.1.1 Planning the Installation Site

### NOTE

Before performing the installation it is important to plan the installation of the frequency converter. Neglecting this may result in extra work during and after installation.

Select the best possible operation site by considering the following (see details on the following pages, and the respective Design Guides):

- Ambient operating temperature
- Installation method
- How to cool the unit
- Position of the frequency converter
- Cable routing
- Ensure the power source supplies the correct voltage and necessary current
- Ensure that the motor current rating is within the maximum current from the frequency converter
- If the frequency converter is without built-in fuses, ensure that the external fuses are rated correctly.

##### 3.1.2 Receiving the Frequency Converter

When receiving the frequency converter make sure that the packaging is intact, and be aware of any damage that might have occurred to the unit during transport. In case damage has occurred, contact immediately the shipping company to claim the damage.

##### 3.1.3 Transportation and Unpacking

Before unpacking the frequency converter it is recommended that it is located as close as possible to the final installation site.

Remove the box and handle the frequency converter on the pallet, as long as possible.

#### 3.1.4 Lifting

Always lift the frequency converter in the dedicated lifting eyes.

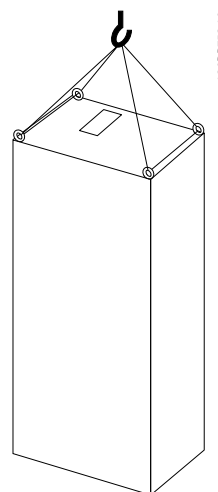

Illustration 3.1 Recommended lifting method, frame size F8.

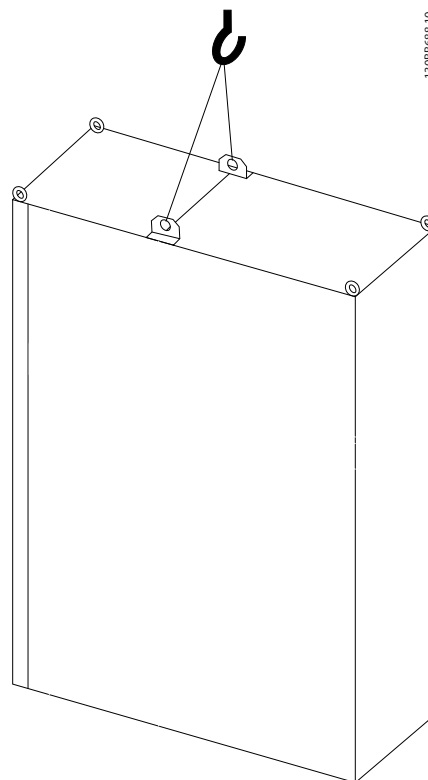
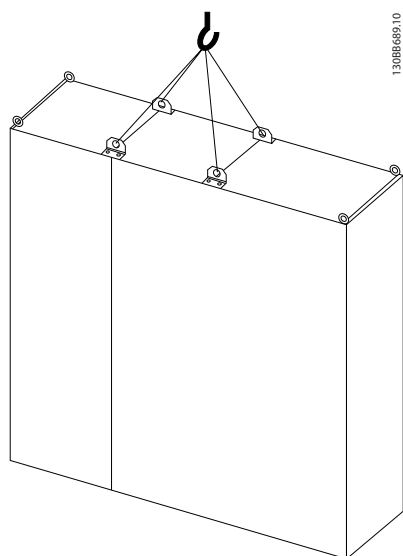

Illustration 3.2 Recommended lifting method, frame size F9/F10.





3

Illustration 3.3 Recommended lifting method, frame size F11/F12/F13/F14.

## NOTE

The plinth is provided in the same packaging as the frequency converter but is not attached during shipment. The plinth is required to allow airflow to the frequency converter to provide proper cooling. The F frames should be positioned on top of the plinth in the final installation location. The angle from the top of the frequency converter to the lifting cable should be 60° or greater. In addition to the drawings above a spreader bar is an acceptable way to lift the F Frame.

3.1.5 Mechanical Dimensions

3

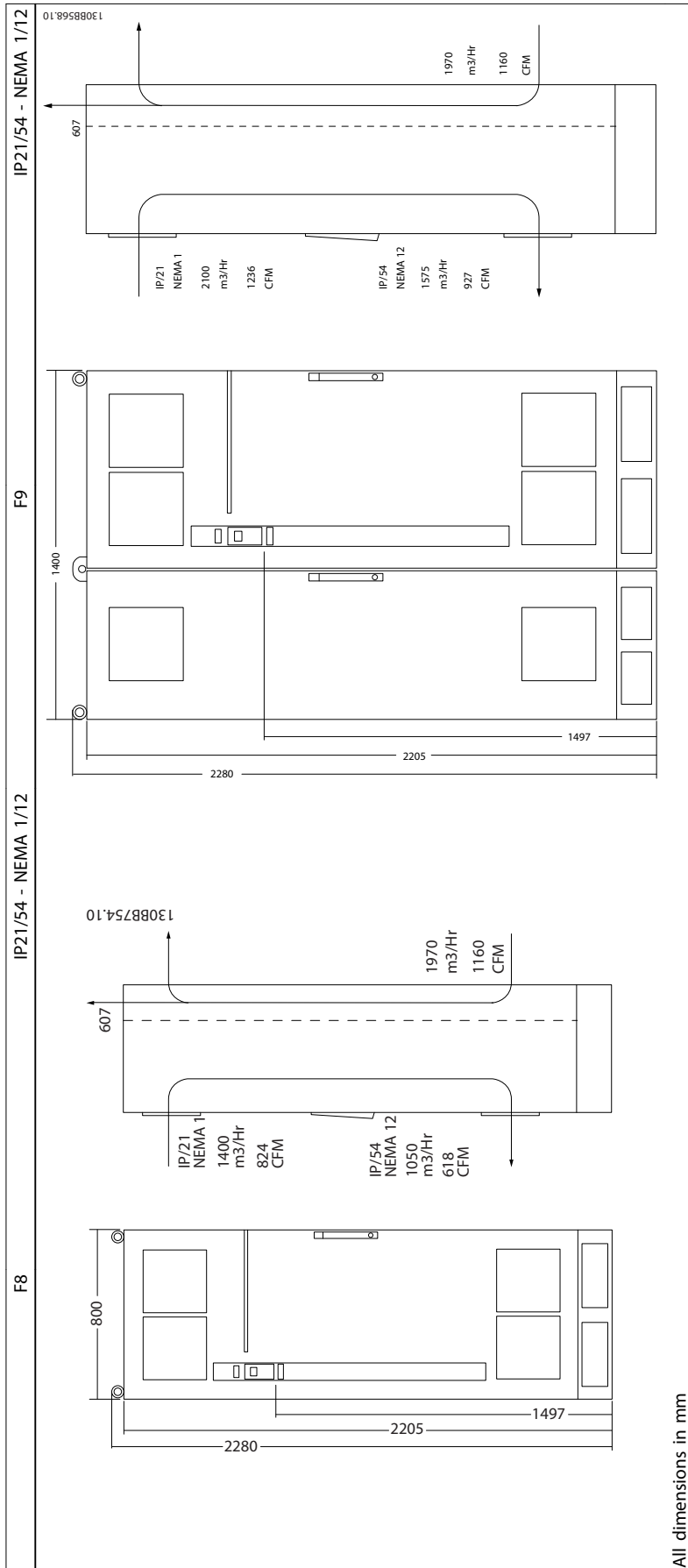

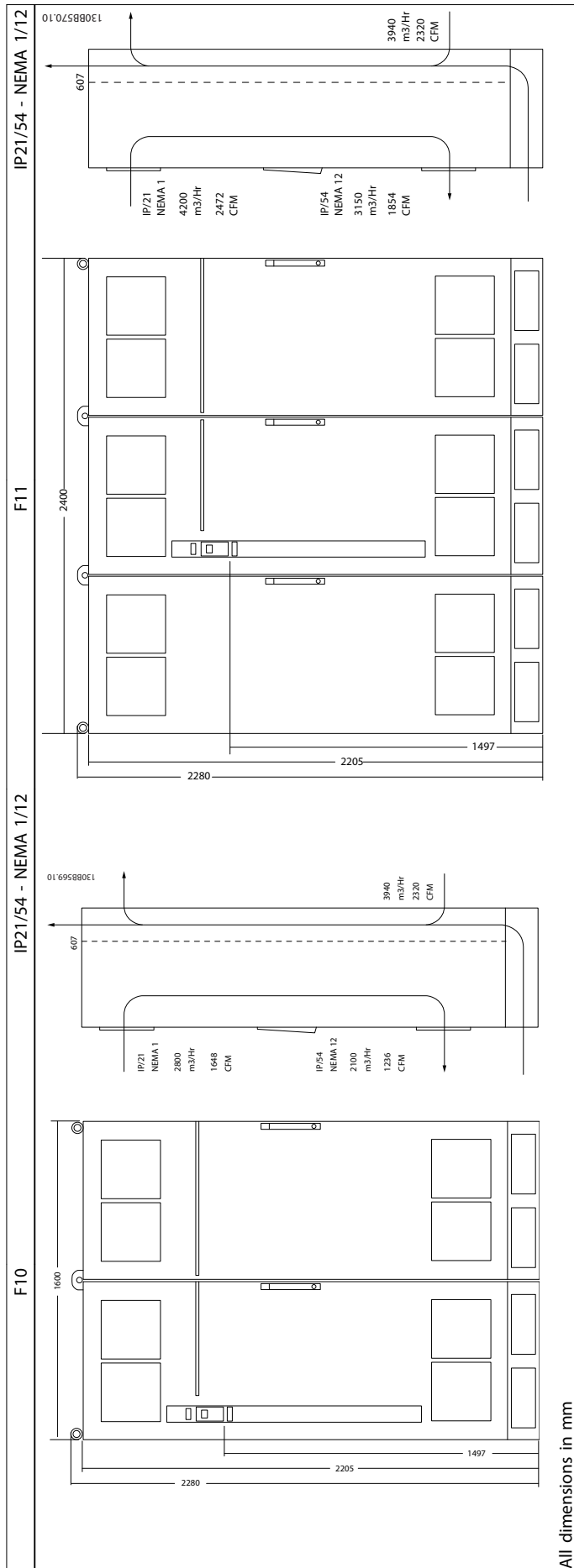

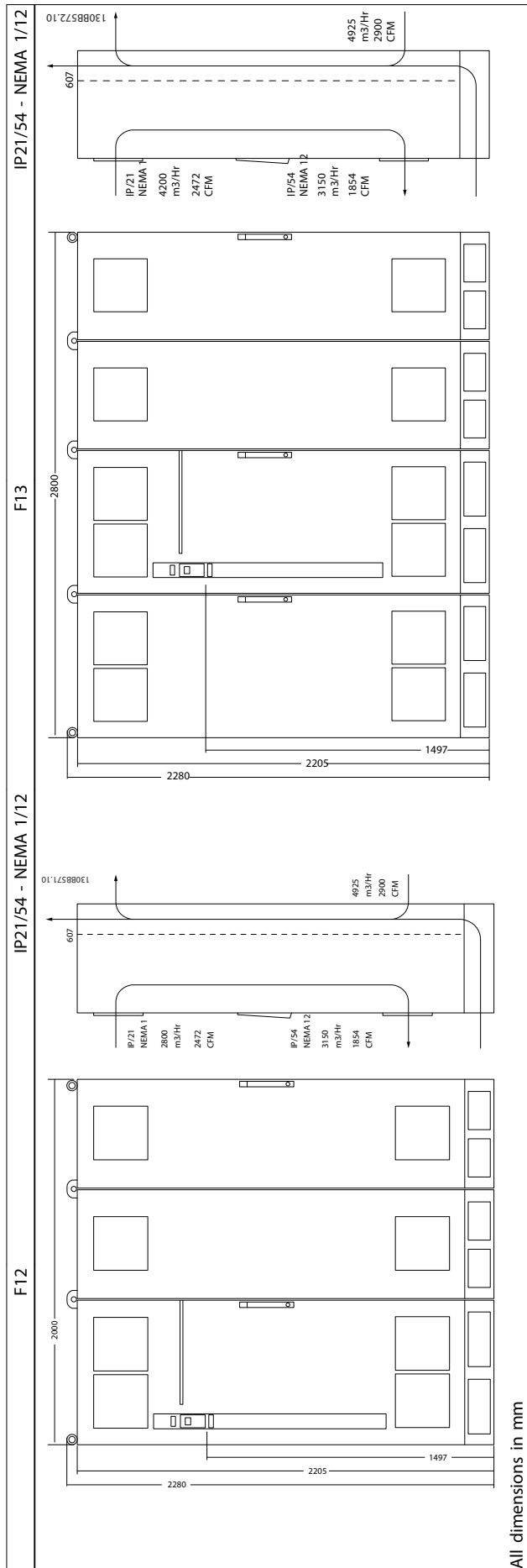

3

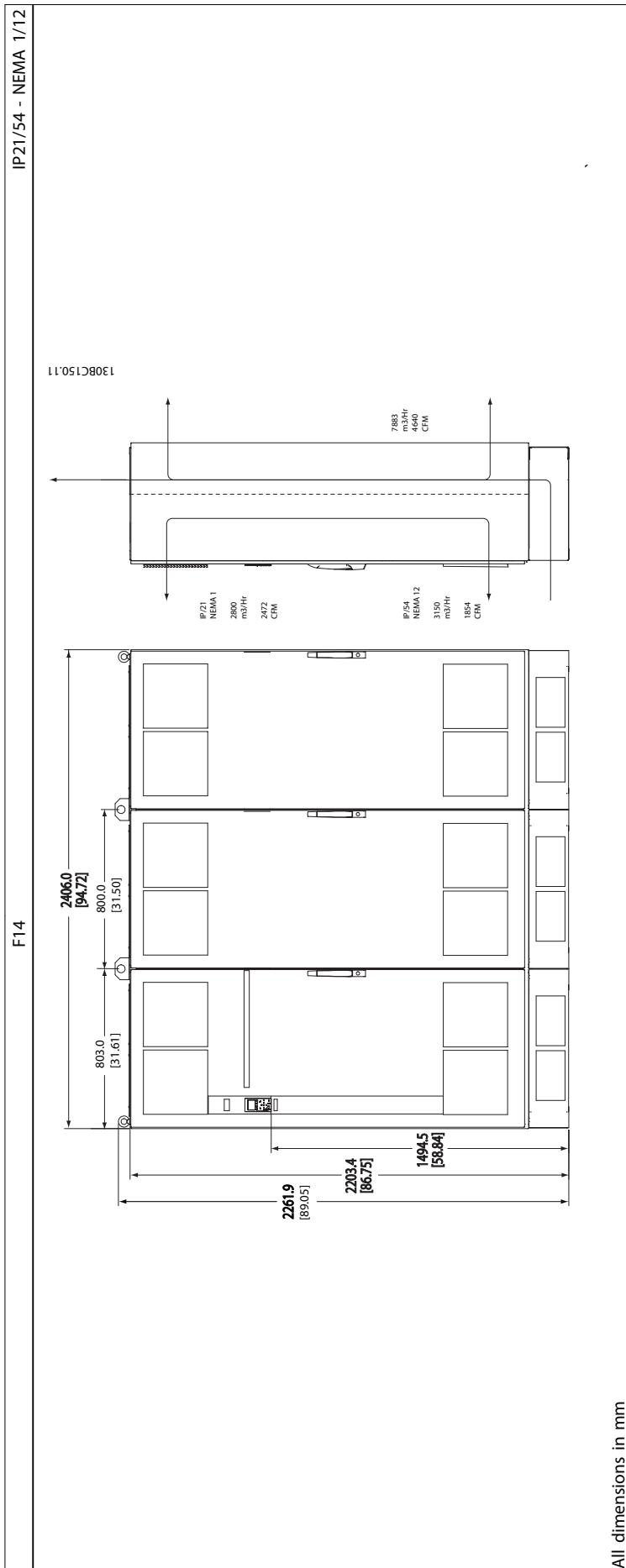

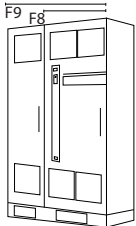

3

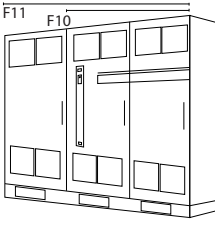
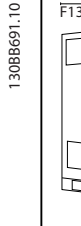
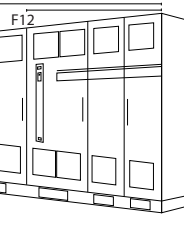
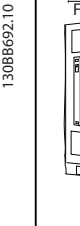
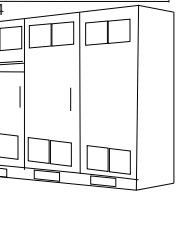
Mechanical dimensions, frame sizes E and F							
Frame size	F8	F9	F10	F11	F12	F13	F14
							
High overload rated power - 160% overload torque	250 - 400 kW (380 - 500 V) 355 - 560 kW (525-690 V)	250 - 400 kW (380 - 500 V) 355 - 56 kW (525-690 V)	450 - 630 kW (380 - 500 V) 630 - 800 kW (525-690 V)	710 - 800 kW (380 - 500 V) 900 - 1200 kW (525-690 V)	450 - 630 kW (380 - 500 V) 630 - 800 kW (525-690 V)	710 - 800 kW (380 - 500 V) 900 - 1200 kW (525-690 V)	1400 kW (525-690 V)
IP NEMA	21, 54 Type 12	21, 54 Type 12	21, 54 Type 12	21, 54 Type 12	21, 54 Type 12	21, 54 Type 12	21, 54 Type 12
Shipping dimensions [mm]							
Height	2324	2324	2324	2324	2324	2324	2362
Width	970	1568	1760	2559	2160	2960	2578
Depth	1130	1130	1130	1130	1130	1130	1130
Drive dimensions [mm]							
Height	2204	2204	2204	2204	2204	2204	2262
Width	800	1400	1600	2400	2000	2800	2400
Depth	606	606	606	606	606	606	608
Max weight [kg]	440	656	880	1096	1022	1238	1410

**NOTE**

The F frames have seven different sizes, F8, F9, F10,F11, F12, and F14 The F8, F10 F12, and F14 consist of an inverter cabinet on the right and rectifier cabinet on the left. The F9, F11 and F13 have an additional options cabinet left of the rectifier cabinet. The F9 is an F8 with an additional options cabinet. The F11 is an F10 with an additional options cabinet. The F13 is an F12 with an additional options cabinet.

### 3.2 Mechanical Installation

Preparation of the mechanical installation of the frequency converter must be done carefully to ensure a proper result and to avoid additional work during installation. Start taking a close look at the mechanical drawings at the end of this instruction to become familiar with the space demands.

#### 3.2.1 Tools Needed

To perform the mechanical installation the following tools are needed:

- Drill with 10 or 12 mm drill
- Tape measure
- Wrench with relevant metric sockets (7-17 mm)
- Extensions to wrench
- Sheet metal punch for conduits or cable glands in IP21/Nema 1 and IP54 units
- Lifting bar to lift the unit (rod or tube max. Ø 25 mm (1 inch), able to lift minimum 400 kg (880 lbs)).
- Crane or other lifting aid to place the frequency converter in position

#### 3.2.2 General Considerations

##### Space

Ensure proper space above and below the frequency converter to allow airflow and cable access. In addition space in front of the unit must be considered to enable opening of the door of the panel.

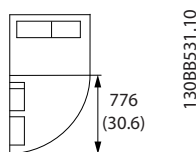

Illustration 3.4 Space in front of IP21/IP54 enclosure type, frame size F8

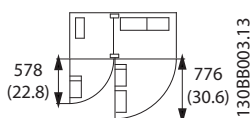

Illustration 3.5 Space in front of IP21/IP54 enclosure type, frame size F9

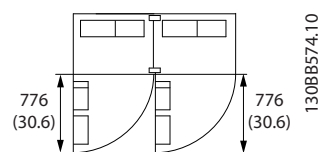

Illustration 3.6 Space in front of IP21/IP54 enclosure type, frame size F10

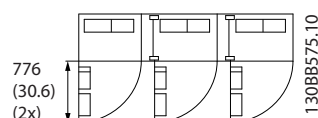

Illustration 3.7 Space in front of IP21/IP54 enclosure type, frame size F11

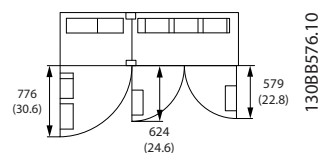

Illustration 3.8 Space in front of IP21/IP54 enclosure type, frame size F12

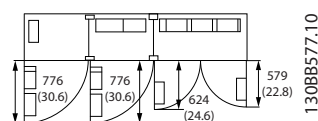

Illustration 3.9 Space in front of IP21/IP54 enclosure type, frame size F13

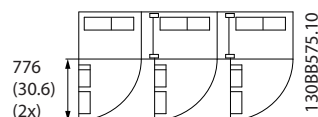

Illustration 3.10 Space in front of IP21/IP54 enclosure type, frame size F14

##### Wire access

Ensure that proper cable access is present including necessary bending allowance.

##### NOTE

All cable lugs/shoes must mount within the width of the terminal bus bar.

### 3.2.3 Terminal Locations, F8-F14 - 12-Pulse

The 12-pulse F enclosures have seven different sizes, F8, F9, F10, F11, F12, F13, and F14. The F8, F10, F12, and F14 consist of an inverter cabinet on the right and rectifier

cabinet on the left. The F9, F11 and F13 have an additional options cabinet left of the rectifier cabinet. The F9 is an F8 with an additional options cabinet. The F11 is an F10 with an additional options cabinet. The F13 is an F12 with an additional options cabinet.

3

#### Terminal locations - Inverter and Rectifier Frame size F8 and F9

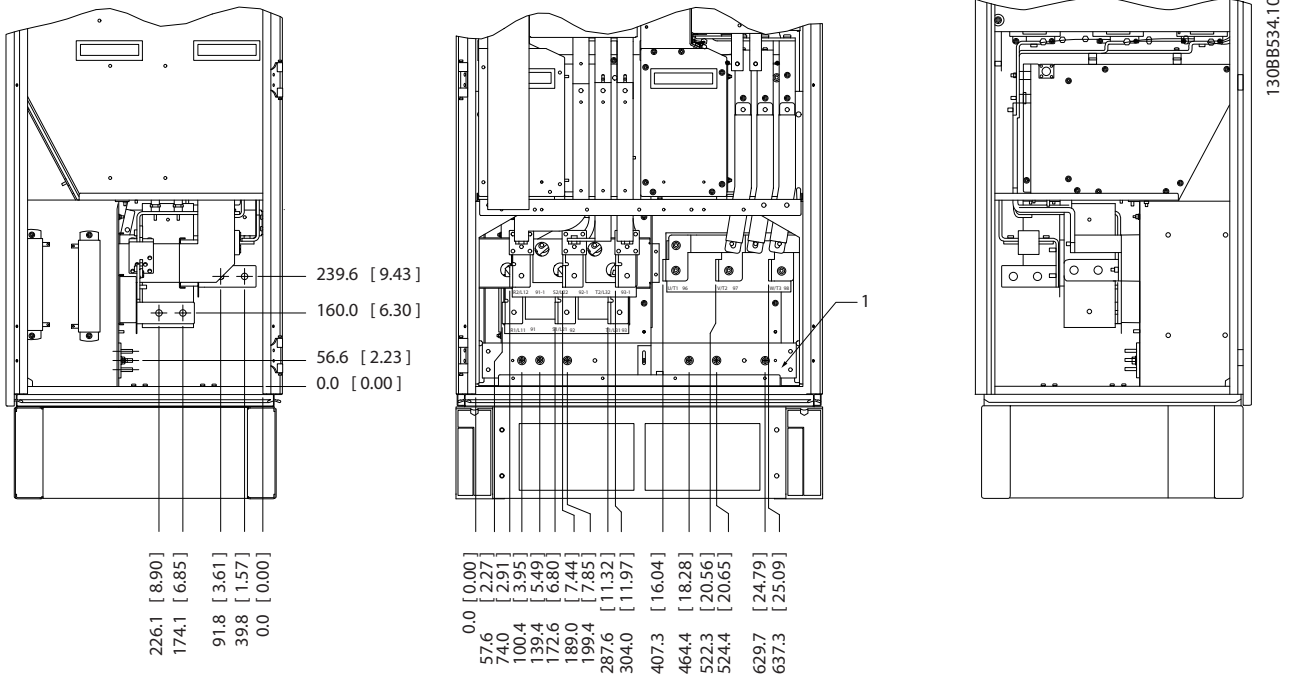

Illustration 3.11 Terminal locations - Inverter and Rectifier Cabinet - F8 and F9 (front, left and right side view). The gland plate is 42 mm below .0 level.

1) Earth ground bar



Terminal locations - Inverter Frame size F10 and F11

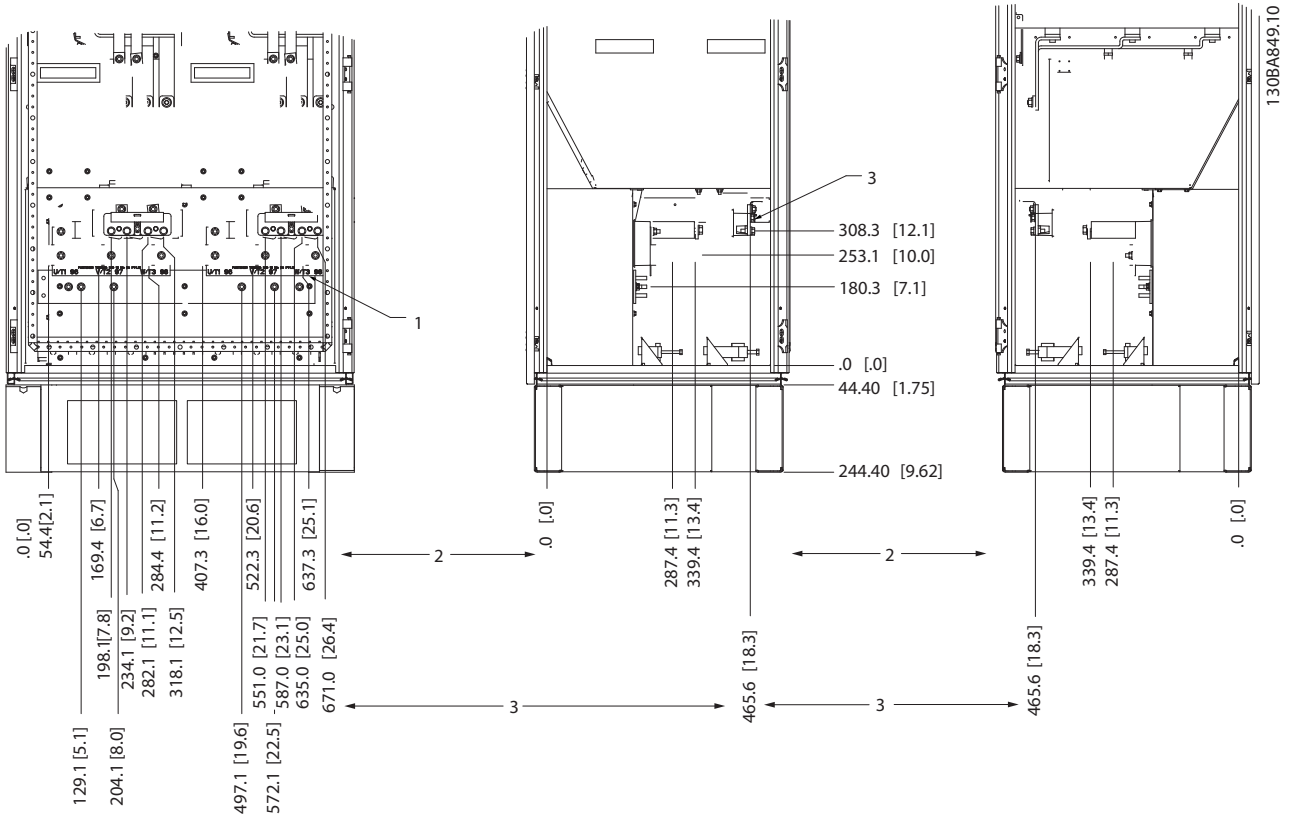

Illustration 3.12 Terminal locations - Inverter Cabinet (front, left and right side view). The gland plate is 42 mm below .0 level.

- 1) Earth ground bar
- 2) Motor terminals
- 3) Brake terminals

Terminal locations - Inverter Frame size F12 and F13

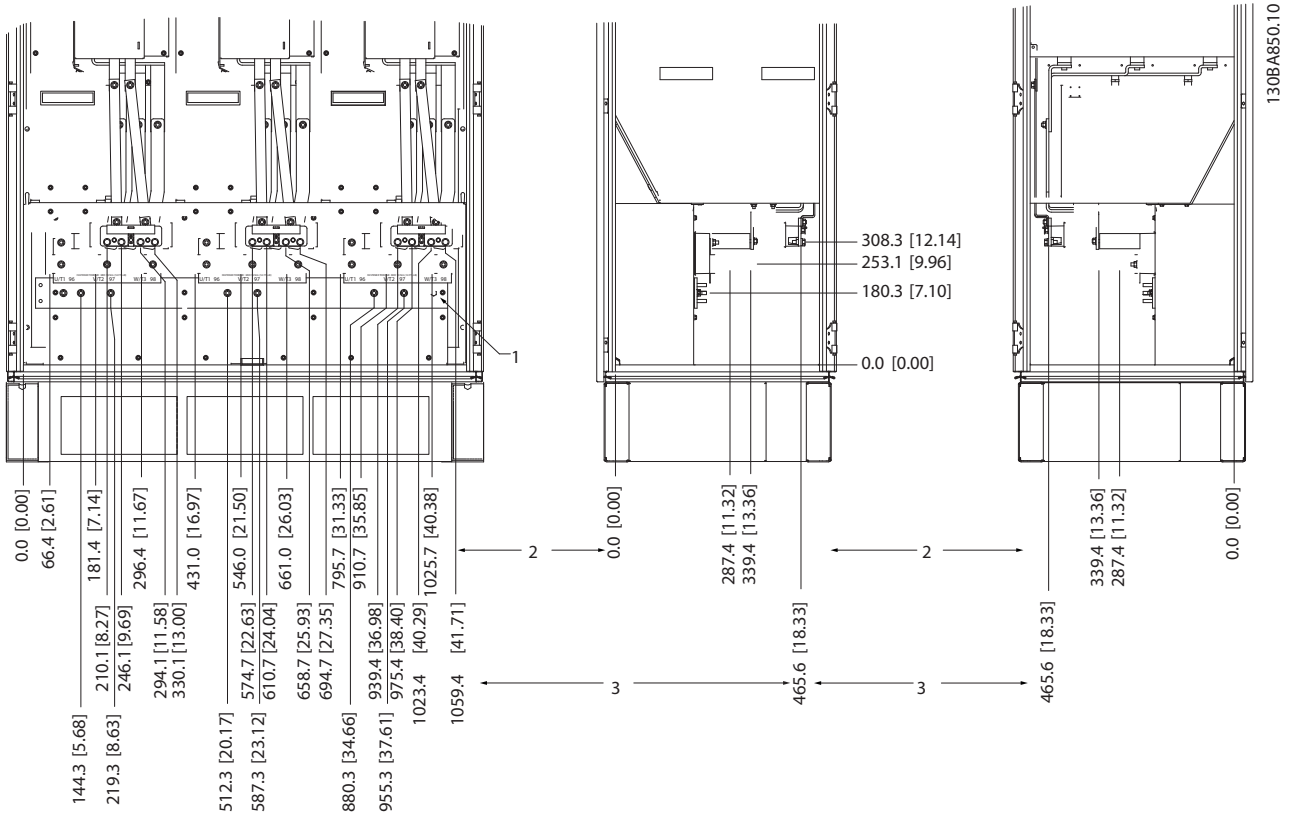
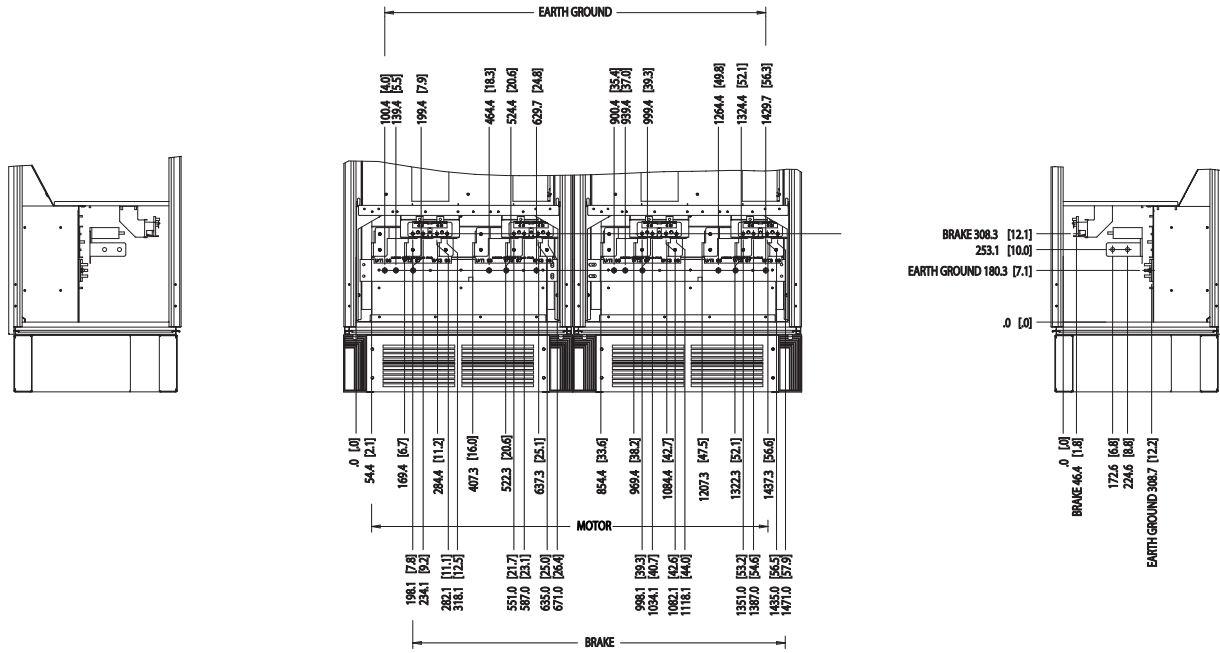

Illustration 3.13 Terminal locations - Inverter Cabinet (front, left and right side view). The gland plate is 42 mm below .0 level.

1) Earth ground bar

Terminal Locations - Inverter Frame Size F14



1308C147.10

3

Illustration 3.14 Terminal Locations - Inverter Cabinet (left, front, and side view). The gland plate is 42 mm below .0 level.

Terminal locations - Rectifier (F10, F11, F12 and F13)

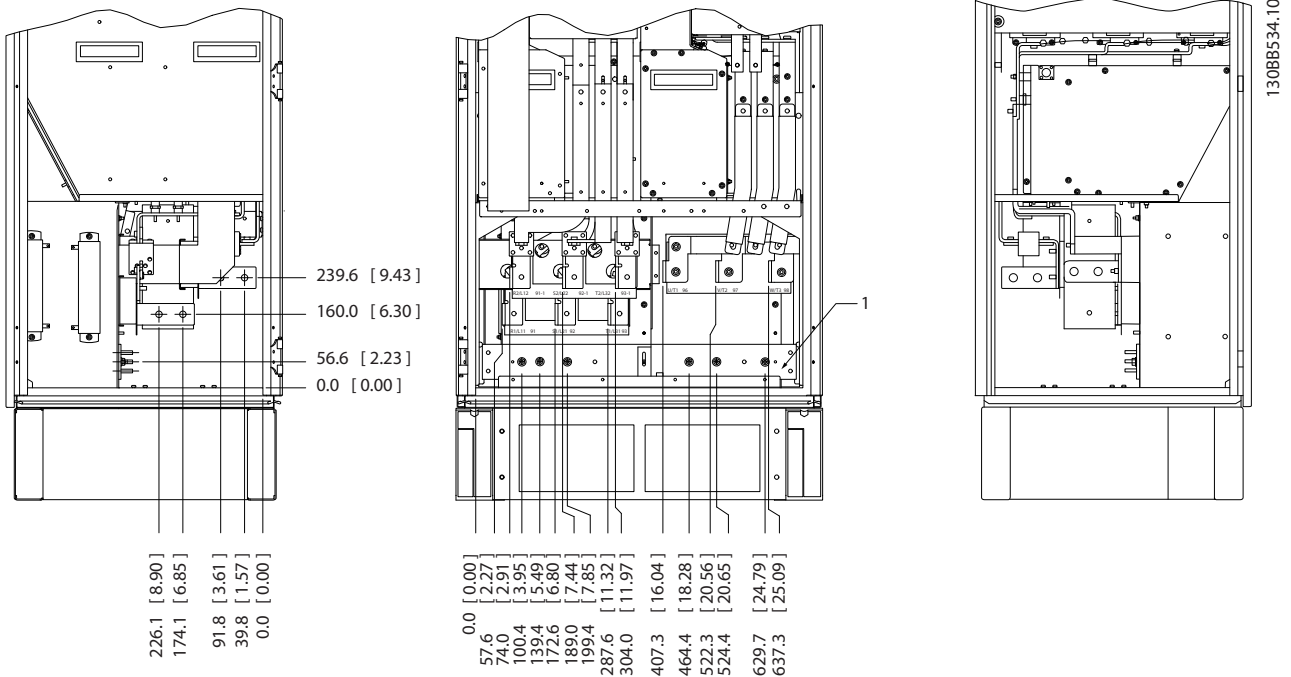
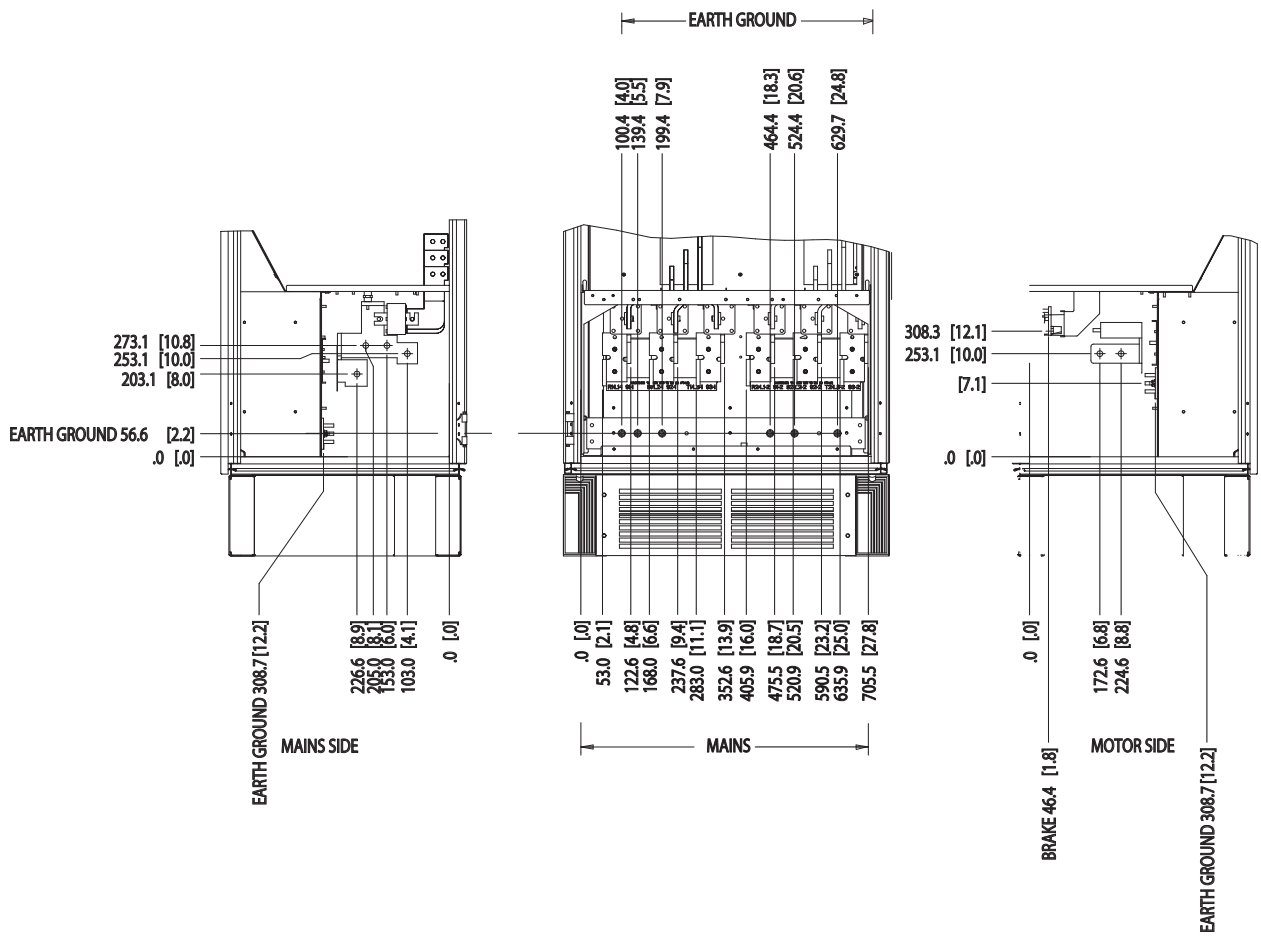

Illustration 3.15 Terminal locations - Rectifier (Left side, front and right side view). The gland plate is 42 mm below .0 level.

- 1) Loadshare Terminal (-)
- 2) Earth ground bar
- 3) Loadshare Terminal (+)

Terminal Locations - Rectifier (F14)



1308C146.10

Illustration 3.16 Terminal Locations - Rectifier (Left side, front and right side view). The gland plate is 42 mm below .0 level.

Terminal locations - Options Cabinet Frame Size F9

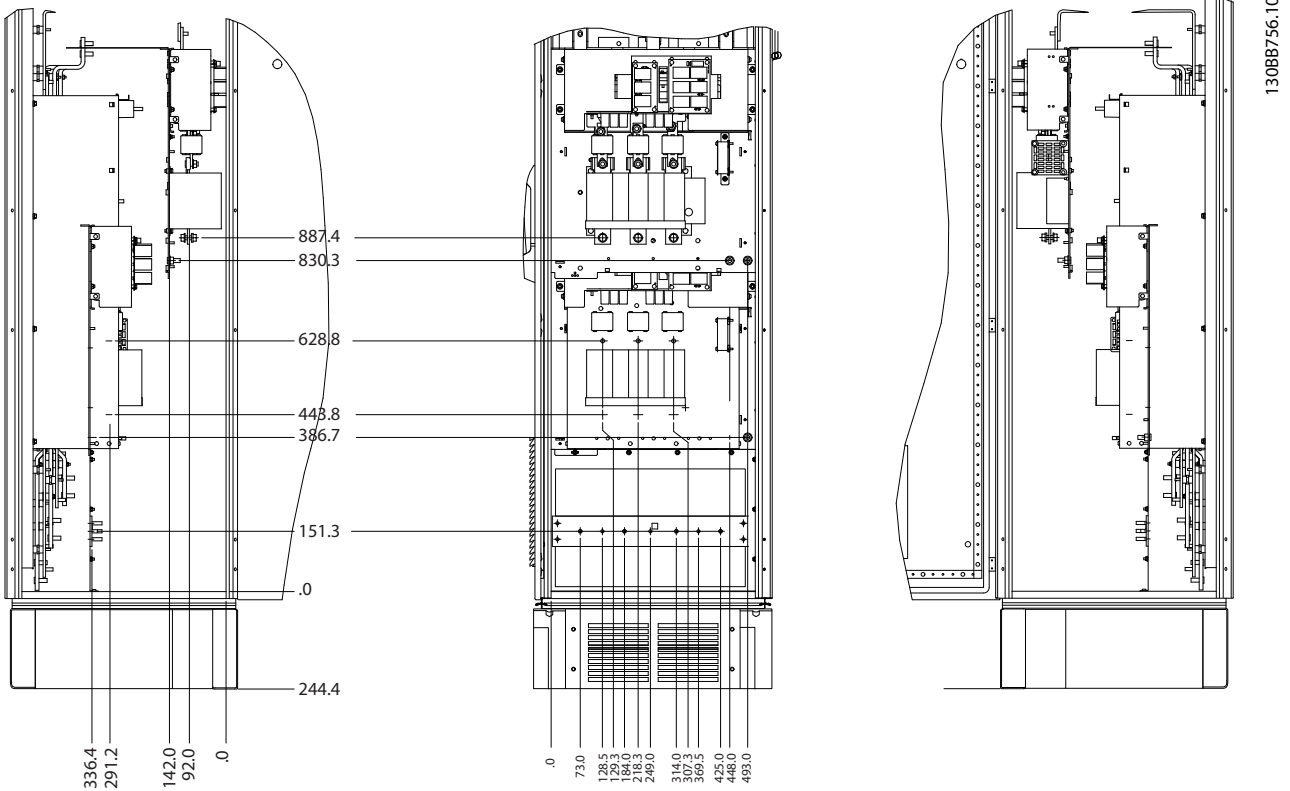

Illustration 3.17 Terminal locations - Options Cabinet (Left side, front and right side view).

Terminal locations - Options Cabinet Frame Size F11/F13

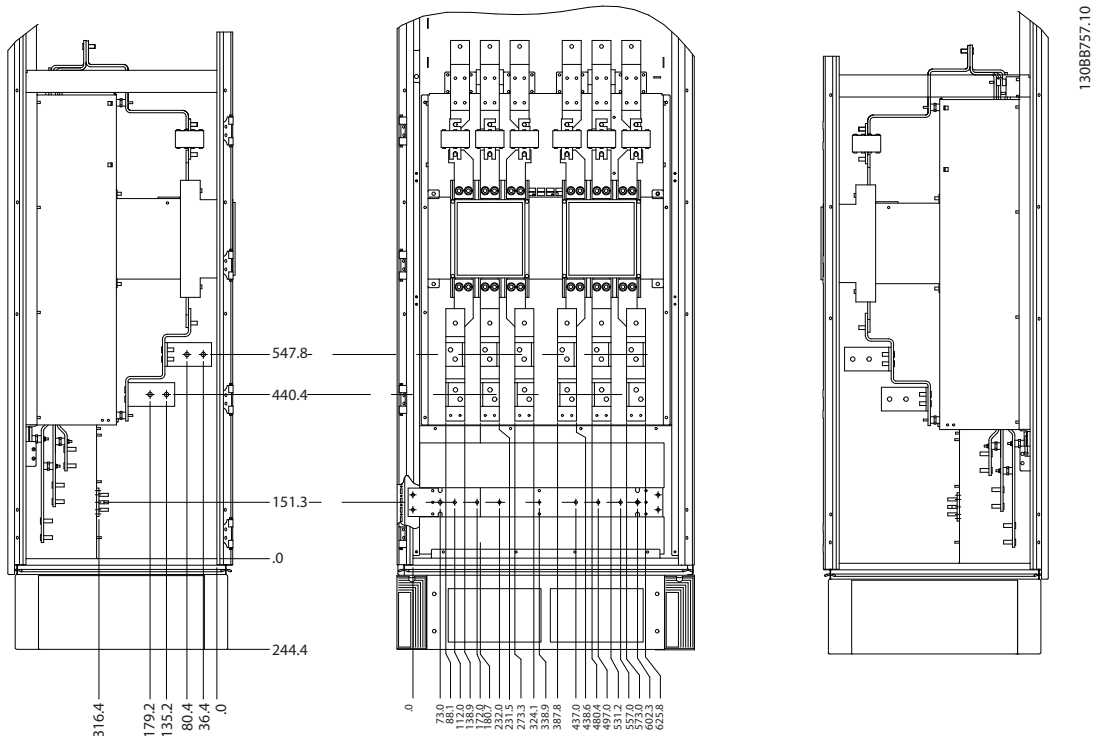

Illustration 3.18 Terminal locations - Options Cabinet (Left side, front and right side view).

### 3.2.4 Cooling and Airflow

#### Cooling

Cooling can be obtained in different ways, by using the cooling ducts in the bottom and the top of the unit, by taking air in and out the back of the unit or by combining the cooling possibilities.

#### Duct cooling

A dedicated option has been developed to optimize installation of frequency converters in Rittal TS8 enclosures utilizing the fan of the frequency converter for forced air cooling of the backchannel. The air out the top of the enclosure could but ducted outside a facility so the heat loses from the backchannel are not dissipated within the control room reducing air-conditioning requirements of the facility.

#### Back cooling

The backchannel air can also be ventilated in and out the back of a Rittal TS8 enclosure. This offers a solution where the backchannel could take air from outside the facility and return the heat loses outside the facility thus reducing air-conditioning requirements.

#### Airflow

The necessary airflow over the heat sink must be secured. The flow rate is shown below.

Enclosure protection	Door fan(s) / Top fan airflow	Heatsink fan(s)
IP21/NEMA 1	700 m <sup>3</sup> /h (412 cfm)*	985 m <sup>3</sup> /h (580 cfm)*
IP54/NEMA 12	525 m <sup>3</sup> /h (309 cfm)*	985 m <sup>3</sup> /h (580 cfm)*

Table 3.1 Heatsink Air Flow

\* Airflow per fan. Frame size F contain multiple fans.

#### NOTE

The fan runs for the following reasons:

1. AMA
2. DC Hold
3. Pre-Mag
4. DC Brake
5. 60% of nominal current is exceeded
6. Specific heatsink temperature exceeded (power size dependent).

Once the fan is started it will run for minimum 10 minutes.

#### External ducts

If additional duct work is added externally to the Rittal cabinet the pressure drop in the ducting must be calculated. Use the charts below to derate the frequency converter according to the pressure drop.

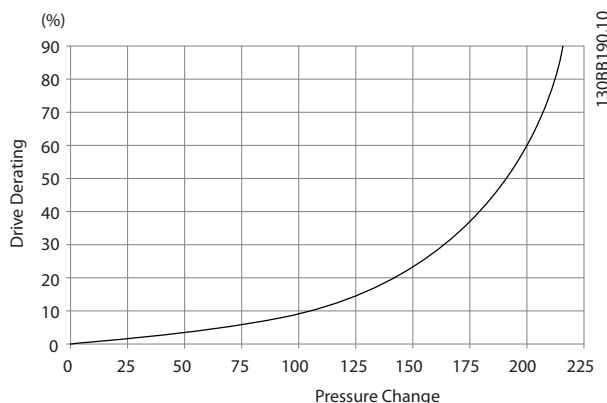

Illustration 3.19 F frame Derating vs. Pressure Change (Pa)

Drive air flow: 985 m<sup>3</sup>/h (580 cfm)

### 3.2.5 Gland/Conduit Entry - IP21 (NEMA 1) and IP54 (NEMA12)

Cables are connected through the gland plate from the bottom. Remove the plate and plan where to place the entry for the glands or conduits. Prepare holes in the marked area on the drawing.

#### NOTE

The gland plate must be fitted to the frequency converter to ensure the specified protection degree, as well as ensuring proper cooling of the unit. If the gland plate is not mounted, the frequency converter may trip on Alarm 69, Pwr. Card Temp

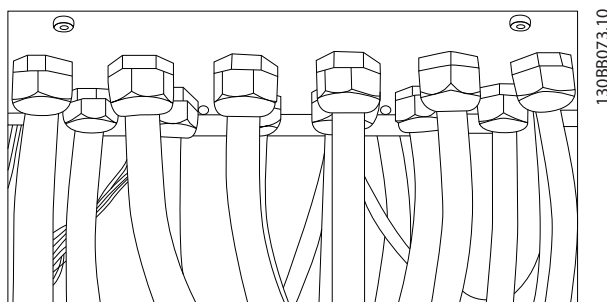
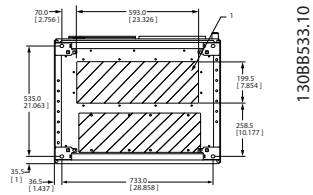

Illustration 3.20 Example of Proper Installation of the Gland Plate.

3

Frame size F8



Frame size F9

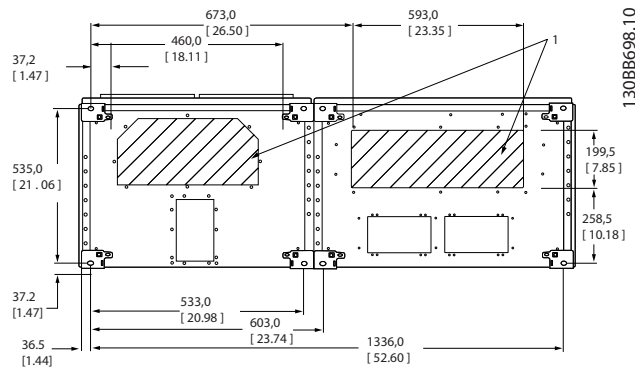

Frame size F10

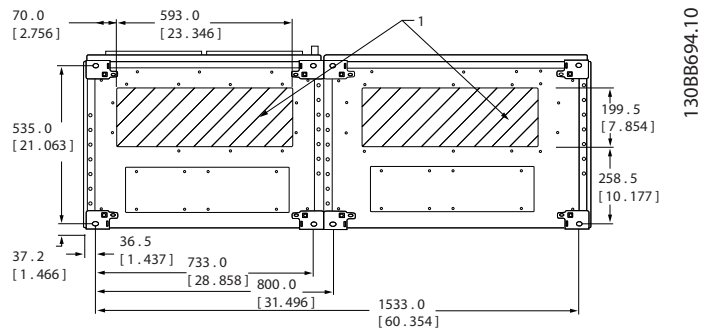



Frame size F11

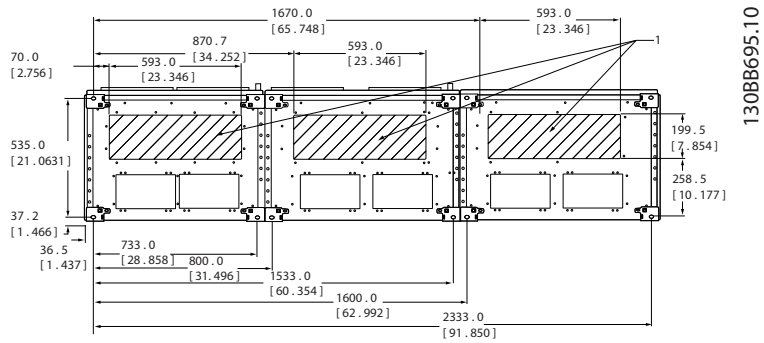

Frame size F12

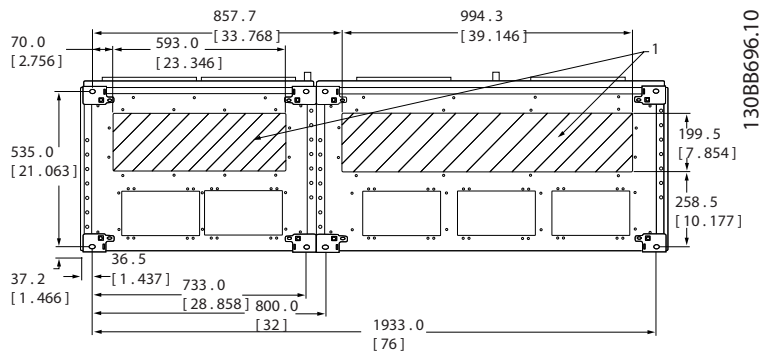

Frame size F13

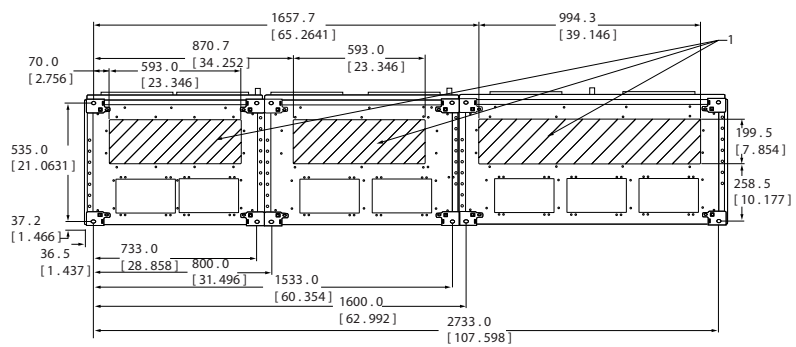

Frame size F 14

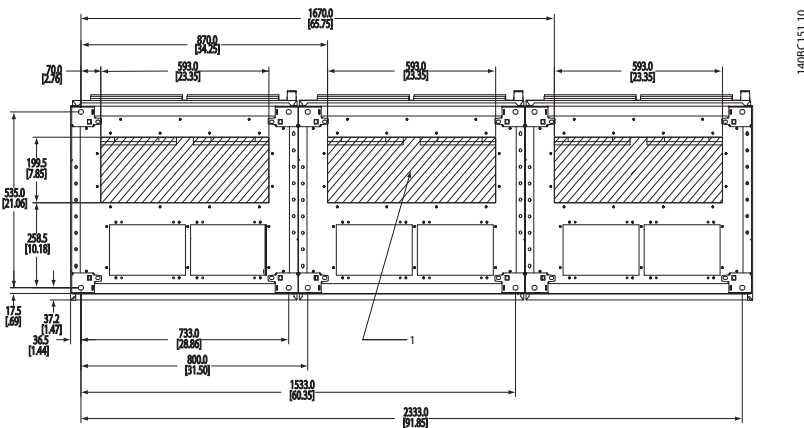

F8-F14: Cable entries viewed from the bottom of the frequency converter - 1) Place conduits in marked areas

### 3.3 Field Installation of Options

#### Space Heaters and Thermostat

Mounted on the cabinet interior of frame size F10-F14 frequency converters, space heaters controlled via automatic thermostat help control humidity inside the enclosure, extending the lifetime of frequency converter components in damp environments. The thermostat default settings turn on the heaters at 10°øC (50° F) and turn them off at 15.6° C (60°øF).

#### Cabinet Light with Power Outlet

A light mounted on the cabinet interior of frame size F10-F14 frequency converters increase visibility during servicing and maintenance. The housing the light includes a power outlet for temporarily powering tools or other devices, available in two voltages:

- 230 V, 50 Hz, 2.5 A, CE/ENEC
- 120 V, 60 Hz, 5 A, UL/CUL

#### Transformer Tap Setup

If the Cabinet Light & Outlet and/or the Space Heaters & Thermostat are installed Transformer T1 requires the taps to be set to the proper input voltage. A 380-480/500 V unit is initially set to the 525 V tap and a 525-690 V unit is set to the 690 V tap to insure that no over-voltage of secondary equipment occurs if the tap is not changed before power is applied. See *Table 3.2* to set the proper tap at terminal T1 located in the rectifier cabinet. For location in the frequency converter, see illustration of rectifier in *Illustration 3.21*.

Input Voltage Range [V]	Tap to Select [V]
380-440	400
441-490	460
491-550	525
551-625	575
626-660	660
661-690	690

#### NAMUR Terminals

NAMUR is an international association of automation technology users in the process industries, primarily chemical and pharmaceutical industries in Germany. Selection of this option provides terminals organized and labeled to the specifications of the NAMUR standard for frequency converter input and output terminals. This requires MCB 112 PTC Thermistor Card and MCB 113 Extended Relay Card.

#### RCD (Residual Current Device)

Uses the core balance method to monitor ground fault currents in grounded and high-resistance grounded systems (TN and TT systems in IEC terminology). There is a pre-warning (50% of main alarm set-point) and a main alarm set-point. Associated with each set-point is an SPDT alarm relay for external use. Requires an external "window-type" current transformer (supplied and installed by customer).

- Integrated into the frequency converter's safe-stop circuit
- IEC 60755 Type B device monitors AC, pulsed DC, and pure DC ground fault currents
- LED bar graph indicator of the ground fault current level from 10–100% of the set-point
- Fault memory
- TEST/RESET button

#### Insulation Resistance Monitor (IRM)

Monitors the insulation resistance in ungrounded systems (IT systems in IEC terminology) between the system phase conductors and ground. There is an ohmic pre-warning and a main alarm set-point for the insulation level. Associated with each set-point is an SPDT alarm relay for external use.

#### NOTE

Only one insulation resistance monitor can be connected to each ungrounded (IT) system.

- Integrated into the frequency converter's safe-stop circuit
- LCD display of the ohmic value of the insulation resistance
- Fault Memory
- [Info], [Test], and [Reset] keys

#### Manual Motor Starters

Provide 3-phase power for electric blowers often required for larger motors. Power for the starters is provided from the load side of any supplied contactor, circuit breaker, or disconnect switch. Power is fused before each motor starter, and is off when the incoming power to the frequency converter is off. Up to two starters are allowed (one if a 30 A, fuse-protected circuit is ordered). Integrated into the frequency converter's safe-stop circuit. Unit features include:

- Operation switch (on/off)
- Short-circuit and overload protection with test function
- Manual reset function

#### 30 Ampere, Fuse-Protected Terminals

- 3-phase power matching incoming mains voltage for powering auxiliary customer equipment
- Not available if two manual motor starters are selected
- Terminals are off when the incoming power to the frequency converter is off
- Power for the fused protected terminals is provided from the load side of any supplied circuit breaker or disconnect switch.

### 24 V DC Power Supply

- 5 A, 120 W, 24 V DC
- Protected against output over-current, overload, short circuits, and over-temperature
- For powering customer-supplied accessory devices such as sensors, PLC I/O, contactors, temperature probes, indicator lights, and/or other electronic hardware
- Diagnostics include a dry DC-ok contact, a green DC-ok LED, and a red overload LED

### External Temperature Monitoring

Designed for monitoring temperatures of external system components, such as the motor windings and/or bearings. Includes eight universal input modules plus two dedicated thermistor input modules. All ten modules are integrated into the frequency converter's safe-stop circuit and can be monitored via a fieldbus network (requires the purchase of a separate module/bus coupler).

#### Universal inputs (8)

Signal types:

- RTD inputs (including Pt100), 3-wire or 4-wire
- Thermocouple
- Analog current or analog voltage

Additional features:

- One universal output, configurable for analog voltage or analog current
- Two output relays (N.O.)
- Dual-line LC display and LED diagnostics
- Sensor lead wire break, short-circuit, and incorrect polarity detection
- Interface setup software

#### Dedicated thermistor inputs (2)

Features:

- Each module capable of monitoring up to six thermistors in series
- Fault diagnostics for wire breakage or short-circuits of sensor leads
- ATEX/UL/CSA certification
- A third thermistor input can be provided by the PTC Thermistor Option Card MCB 112, if necessary

## 3.3 Electrical Installation

### 3.3.1 Transformer Selection

The frequency converter must be used with a 12-pulse isolation transformer.

### 3.3.2 Power Connections 12-Pulse Drives

#### Cabling and Fusing

#### NOTE

##### Cables General

All cabling must comply with national and local regulations on cable cross-sections and ambient temperature. UL applications require 75° C copper conductors. 75° and 90° C copper conductors are thermally acceptable for the frequency converter to use in non UL applications.

The power cable connections are situated as in *Illustration 3.21*. Dimensioning of cable cross section must be done in accordance with the current ratings and local legislation. See *5.1 General Specifications* for details.

For protection of the frequency converter, the recommended fuses must be used or the unit must be with built-in fuses. Recommended fuses can be seen in *3.3.13 Fuses*. Always ensure that proper fusing is made according to local regulation.

The mains connection is fitted to the mains switch if this is included.

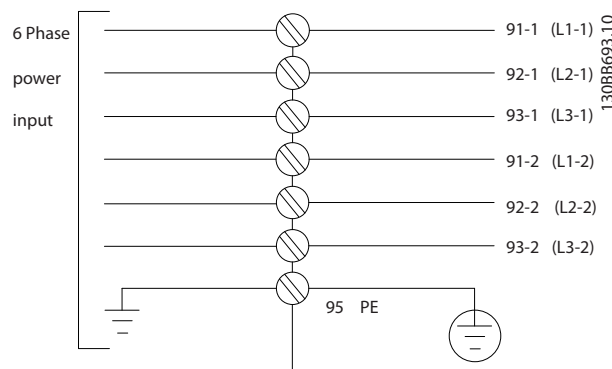

Illustration 3.21

#### NOTE

The motor cable must be screened/armoured. If an unscreened/unarmoured cable is used, some EMC requirements are not complied with. Use a screened/armoured motor cable to comply with EMC emission specifications. For more information, see *EMC Specifications* in the *Design Guide, MG11BXYY* and the *FC 300 Design Guide, MG33BXYY*.

See *5.1 General Specifications* for correct dimensioning of motor cable cross-section and length.

3

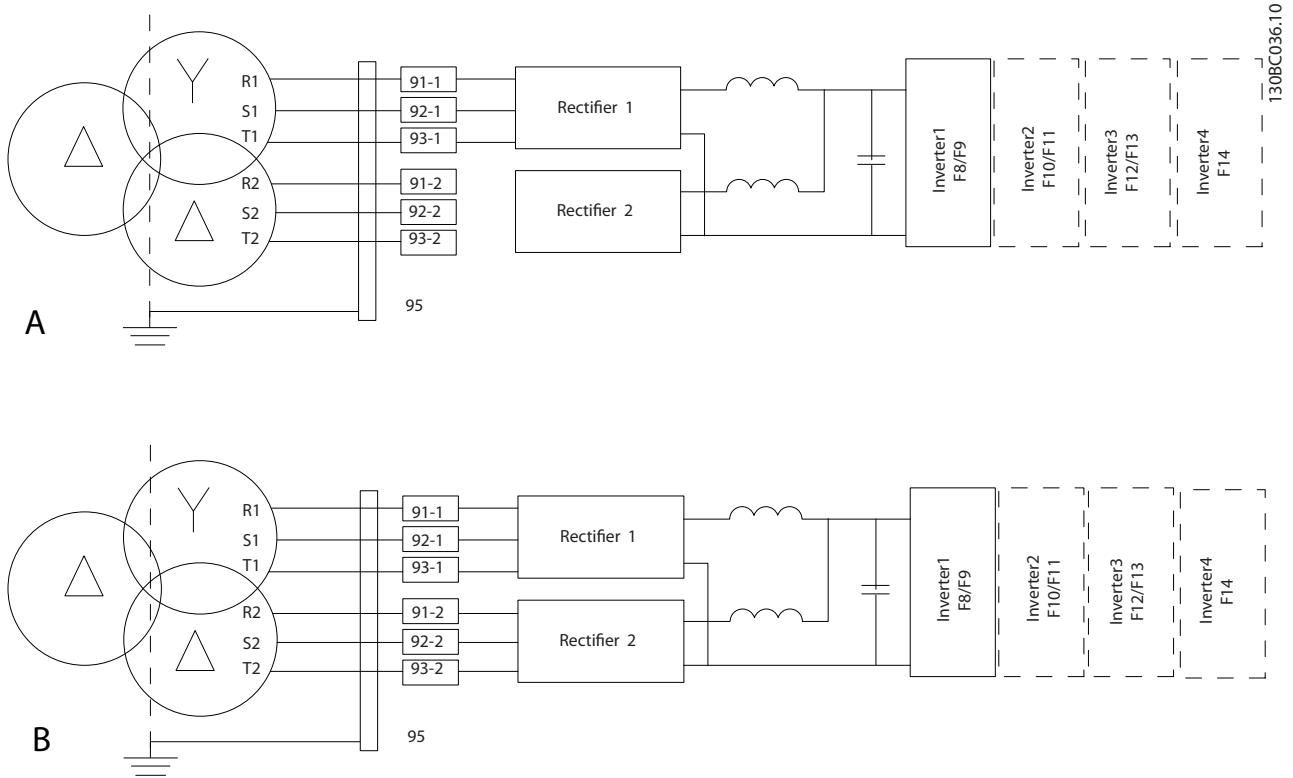

Illustration 3.22

- A) Modified 6-Pulse Connection<sup>1), 2), 3)</sup>
- B) 12-Pulse Connection<sup>2), 4)</sup>

**Notes:**

- 1) 6-pulse connection eliminates the harmonics reduction benefits of the 12-pulse rectifier.
- 2) Suitable for IT and TN mains connection.
- 3) In the unlikely event that one of the 6-pulse modular rectifiers becomes inoperable, it is possible to operate the frequency converter at reduced load with a single 6-pulse rectifier. Contact factory for reconnection details.
- 4) No paralleling of mains cabling is shown here.

**Screening of cables:**

Avoid installation with twisted screen ends (pigtails). They spoil the screening effect at higher frequencies. If it is necessary to break the screen to install a motor isolator or motor contactor, the screen must be continued at the lowest possible HF impedance.

Connect the motor cable screen to both the de-coupling plate of the frequency converter and to the metal housing of the motor.

Make the screen connections with the largest possible surface area (cable clamp). This is done by using the

supplied installation devices within the frequency converter.

**Cable-length and cross-section:**

The frequency converter has been EMC tested with a given length of cable. Keep the motor cable as short as possible to reduce the noise level and leakage currents.

**Switching frequency:**

When frequency converters are used together with Sine-wave filters to reduce the acoustic noise from a motor, the switching frequency must be set according to the instruction in *14-01 Switching Frequency*.

Term. no.	96	97	98	99	
	U	V	W	PE <sup>1)</sup>	Motor voltage 0-100% of mains voltage. 3 wires out of motor
	U1	V1	W1	PE <sup>1)</sup>	Delta-connected
	W2	U2	V2		6 wires out of motor
	U1	V1	W1	PE <sup>1)</sup>	Star-connected U2, V2, W2 U2, V2 and W2 to be interconnected separately.

<sup>1)</sup>Protected Earth Connection

In motors without phase insulation paper or other insulation reinforcement suitable for operation with voltage supply (such as a frequency converter), fit a Sine-wave filter on the output of the frequency converter.

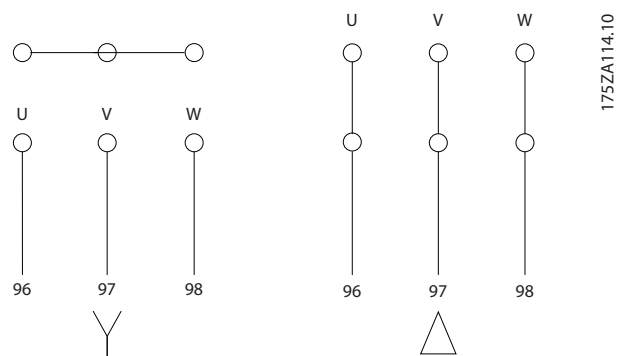

3

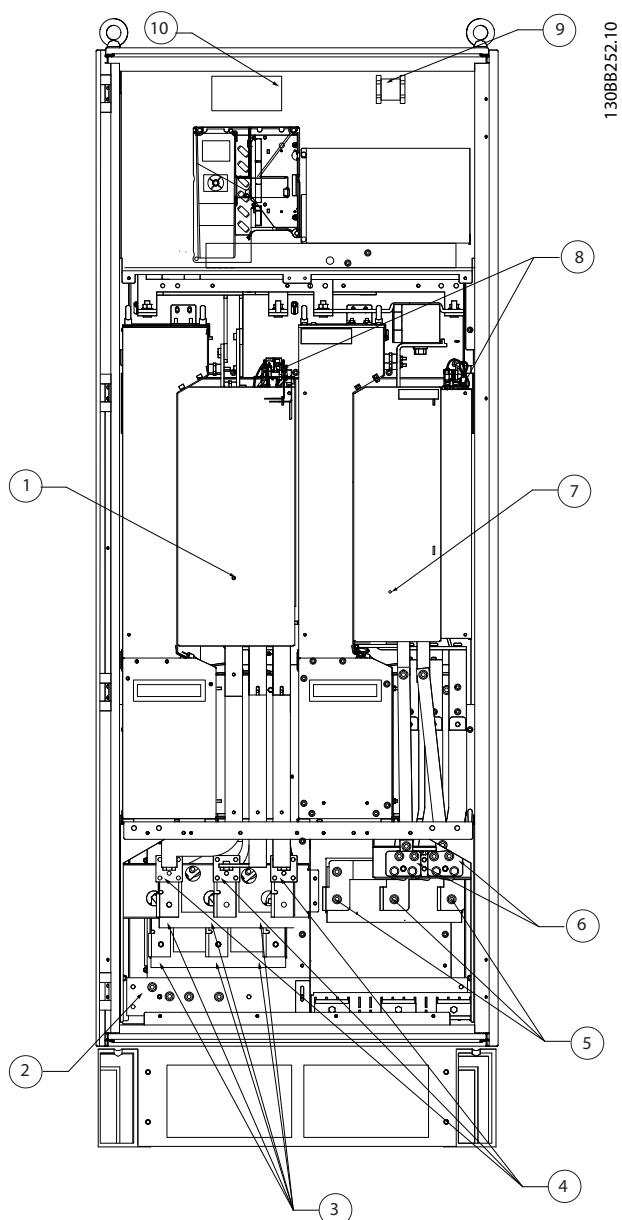
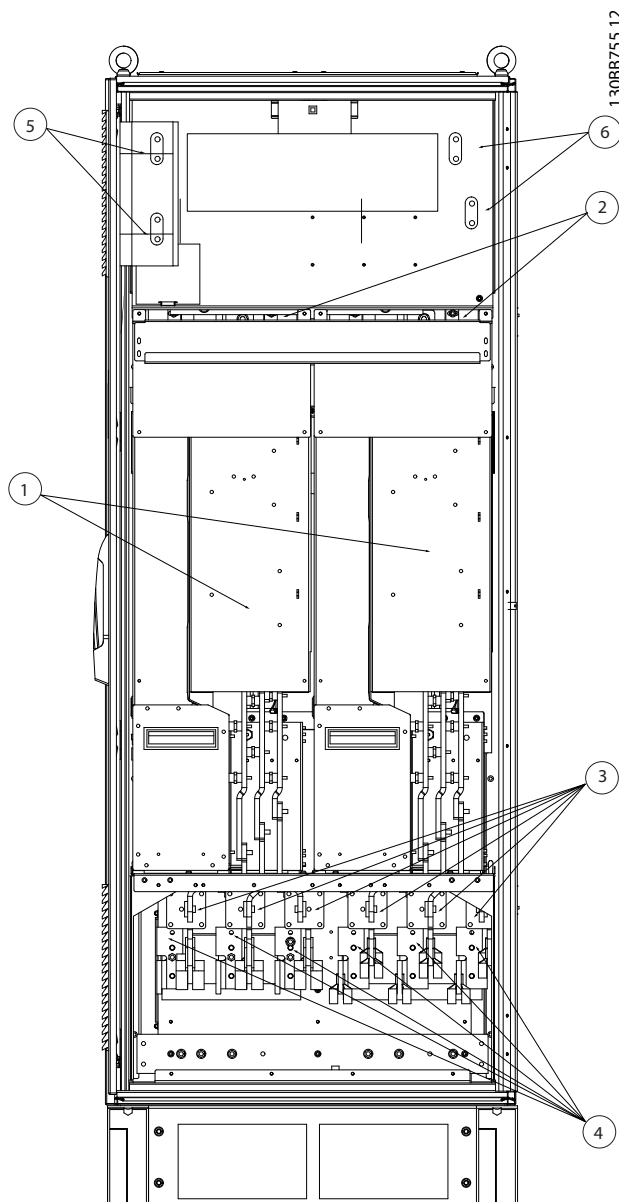

Illustration 3.23 Rectifier and Inverter Cabinet, frame size F8 and F9

1)	12-pulse rectifier module	5)	Motor connection
2)	Ground / Earth PE Terminals		U V W
3)	Mains / Fuses		T1 T2 T3
	R1 S1 T1		96 97 98
	L1-1 L2-1 L3-1	6)	Brake Terminals
	91-1 92-1 93-1		-R +R
4)	Mains / Fuses		81 82
	R2 S2 T2	7)	Inverter Module
	L2-1 L2-2 L3-2	8)	SCR Enable / Disable
	91-2 92-2 93-2	9)	Relay 1 Relay 2
			01 02 03 04 05 06
		10)	Auxillary Fan
			104 106



3

Illustration 3.24 Rectifier Cabinet, frame size F10 and F12

1)	12-pulse rectifier module	4)	Mains
2)	AUX Fan		R1 S1 T1 R2 S2 T2
	100 101 102 103		L1-1 L2-1 L3-1 L1-2 L2-2 L3-2
	L1 L2 L1 L2	5)	DC Bus Connections for common DC Bus
3)	Mains Fuses F10/F12 (6 Pieces)		DC+ DC-
		6)	DC Bus Connections for common DC Bus
			DC+ DC-

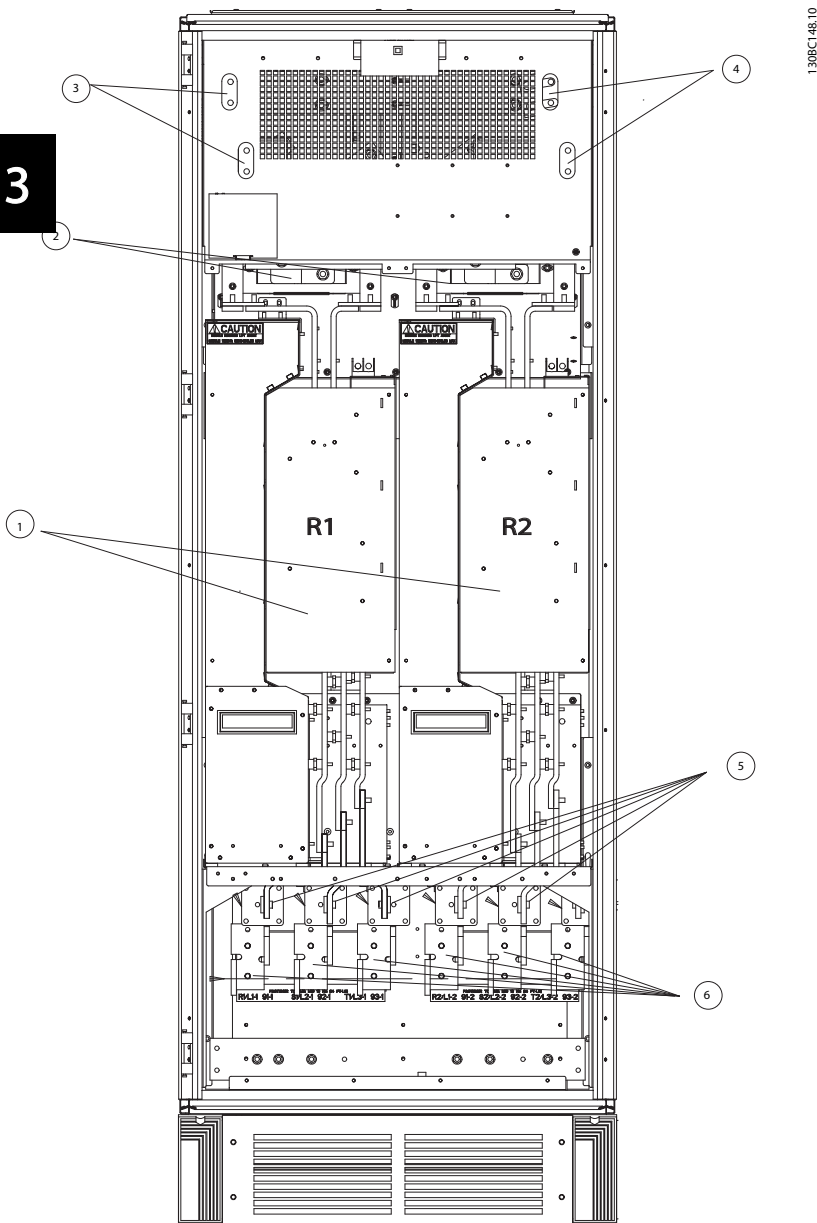

1308CT48:10

Illustration 3.25 Rectifier Cabinet, frame size F14

1)	12-Pulse Rectifier Modules	6)	Mains
2)	N/A		R1 S1 T1 R2 S2 T2
			L1-1 L2-1 L3-1 L1-2 L2-2 L3-2
3)	DC Busbar Access		
4)	DC Busbar Access		
	100 101 102 103		
	L1 L2 L1 L2		
5)	Mains Fuses (6 pieces)		
	-R +R		
	81 82		



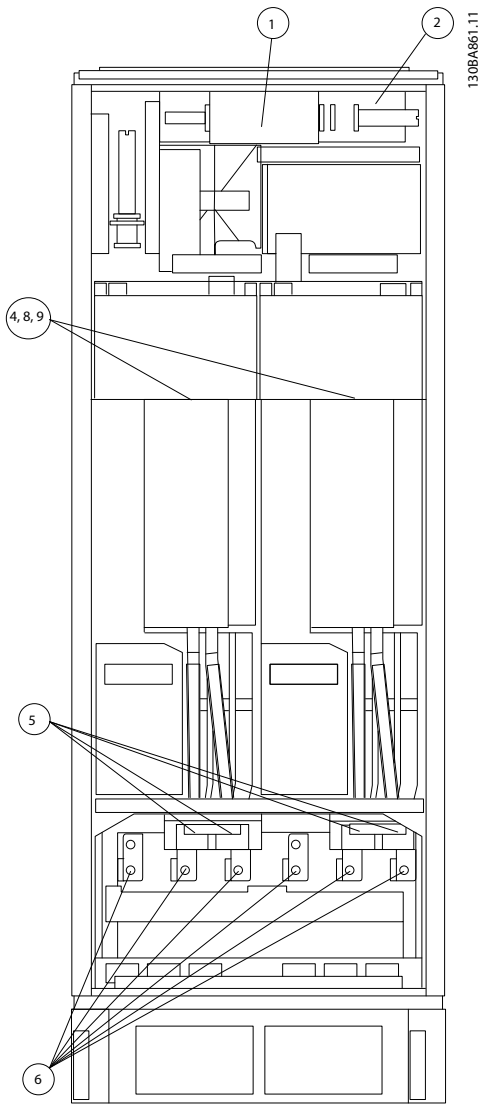

Illustration 3.26 Inverter Cabinet, frame size F10 and F11

1)	External Temperature Monitoring	6)	Motor
2)	AUX Relay		U V W
	01 02 03		96 97 98
	04 05 06		T1 T2 T3
3)	NAMUR	7)	NAMUR Fuse. See fuse tables for part numbers
4)	AUX Fan	8)	Fan Fuses. See fuse tables for part numbers
	100 101 102 103	9)	SMPS Fuses. See fuse tables for part numbers
	L1 L2 L1 L2		
5)	Brake		
	-R +R		
	81 82		

3

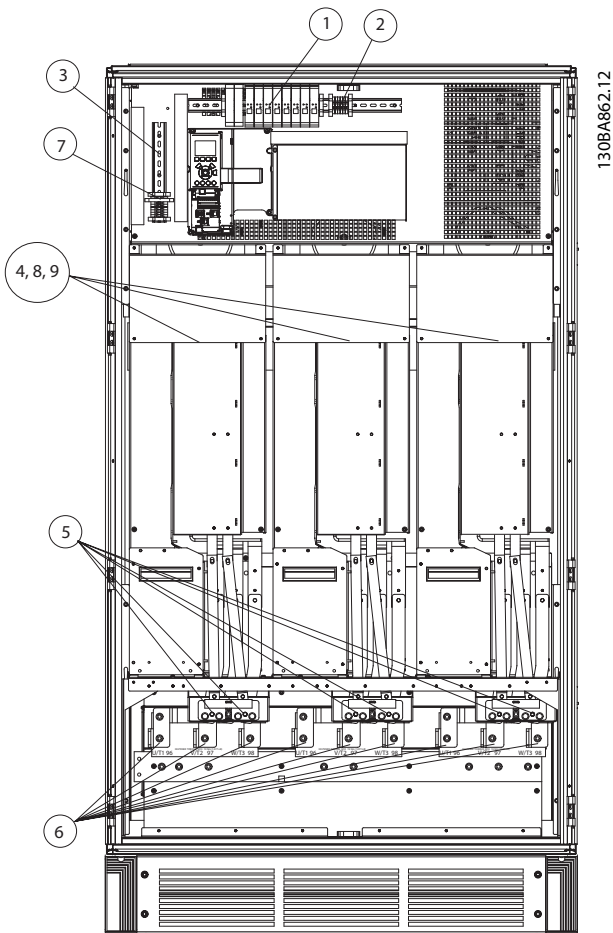

Illustration 3.27 Inverter Cabinet, frame size F12 and F13

1)	External Temperature Monitoring	6)	Motor
2)	AUX Relay		U    V    W
	01 02 03		96    97    98
	04 05 06		T1    T2    T3
3)	NAMUR	7)	NAMUR Fuse. See 3.3.13 Fuses for part numbers
4)	AUX Fan	8)	Fan Fuses. See 3.3.13 Fuses for part numbers
	100 101 102 103	9)	SMPS Fuses. See 3.3.13 Fuses for part numbers
	L1 L2 L1 L2		
5)	Brake		
	-R    +R		
	81    82		

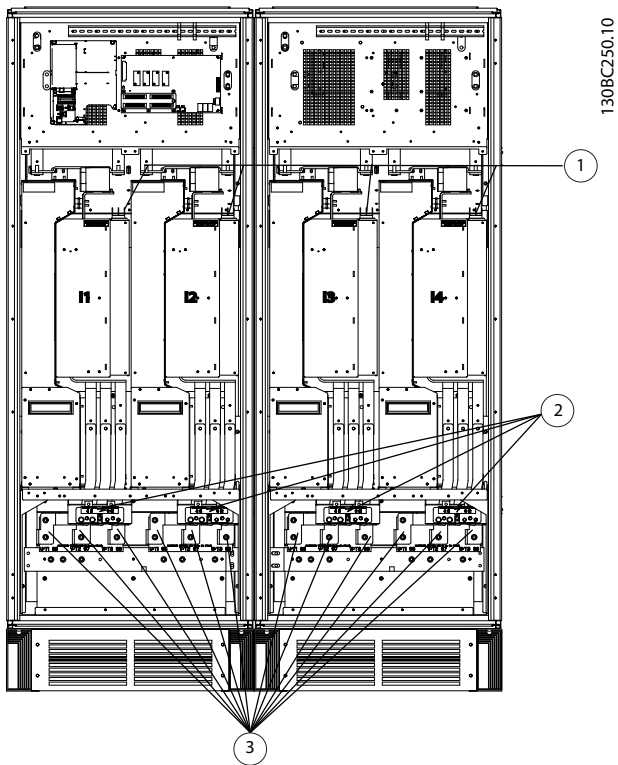

Illustration 3.28 Inverter Cabinet, frame size F14

4)	AUX Fan		6)	Motor	
	100 101 102 103			U V W	
	L1 L2 L1 L2			96 97 98	
5)	Brake			T1 T2 T3	
	-R +R				
	81 82				

3

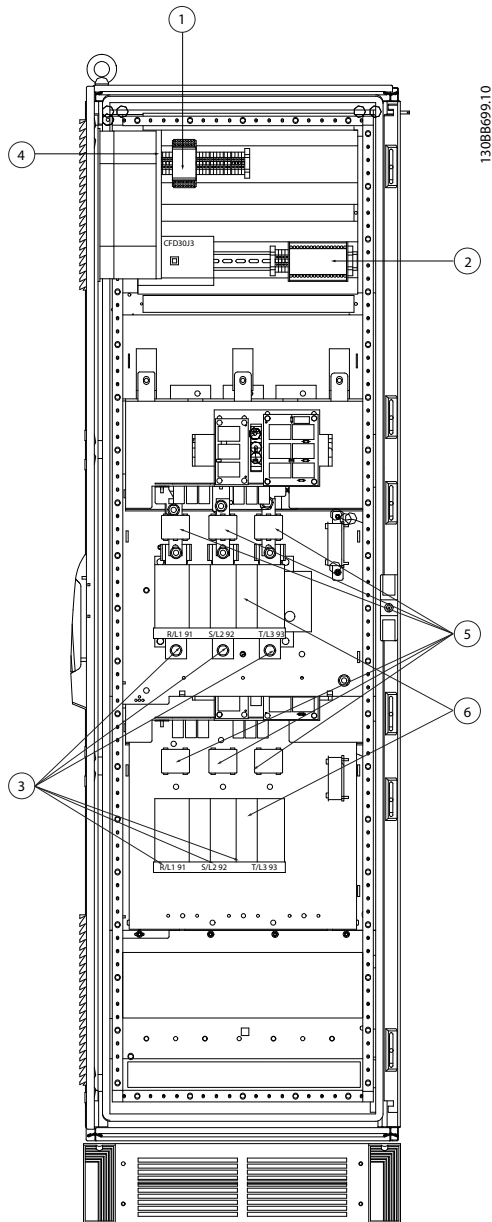
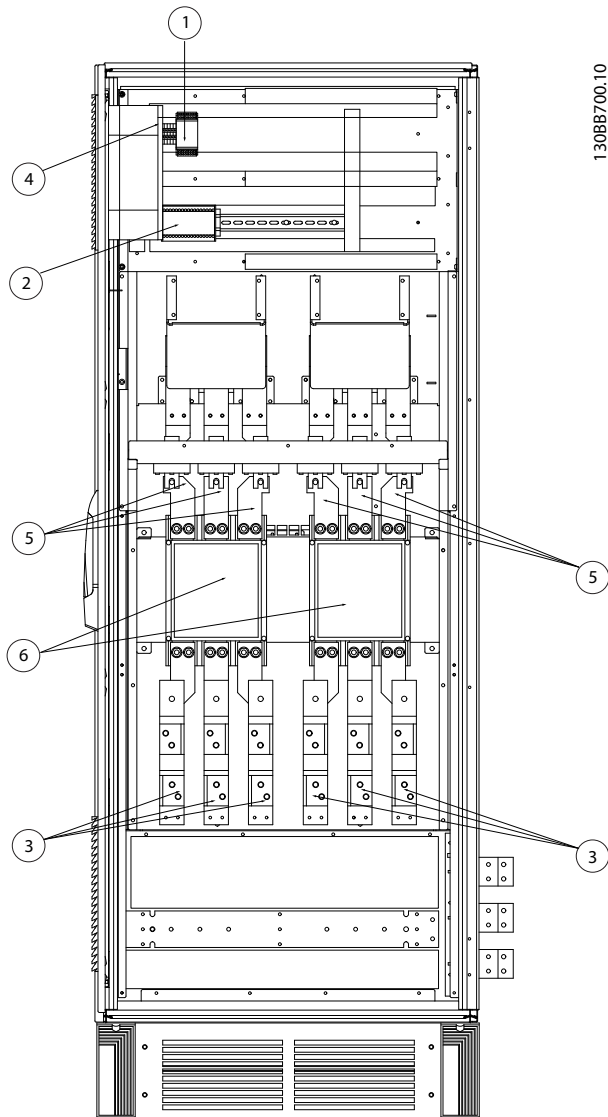

Illustration 3.29 Options Cabinet, frame size F9

1) Pilz Relay Terminal	4) Safety Relay Coil Fuse with Pilz Relay
2) RCD or IRM Terminal	See fuse tables for part numbers
3) Mains/6 phase	5) Mains Fuses, (6 pieces)
R1 S1 T1 R2 S2 T2	See fuse tables for part numbers
91-1 92-1 93-1 91-2 92-2 93-2	6) 2 x 3-phase manual disconnect
L1-1 L2-1 L3-1 L1-2 L2-2 L3-2	



3

Illustration 3.30 Options Cabinet, frame size F11 and F13

1)	Pilz Relay Terminal	4)	Safety Relay Coil Fuse with Pilz Relay
2)	RCD or IRM Terminal		See fuse tables for part numbers
3)	Mains/6 phase	5)	Mains Fuses, (6 pieces)
	R1 S1 T1 R2 S2 T2		See fuse tables for part numbers
	91-1 92-1 93-1 91-2 92-2 93-2	6)	2 x 3-phase manual disconnect
	L1-1 L2-1 L3-1 L1-2 L2-2 L3-2		

3

### 3.3.3 Earthing

The following basic issues need to be considered when installing a frequency converter, so as to obtain electro-magnetic compatibility (EMC).

- Safety earthing: The frequency converter has a high leakage current and must be earthed appropriately for safety reasons. Apply local safety regulations.
- High-frequency earthing: Keep the earth wire connections as short as possible.

Connect the different earth systems at the lowest possible conductor impedance. The lowest possible conductor impedance is obtained by keeping the conductor as short as possible and by using the greatest possible surface area. The metal cabinets of the different devices are mounted on the cabinet rear plate using the lowest possible HF impedance. This avoids having different HF voltages for the individual devices and avoids the risk of radio interference currents running in connection cables that may be used between the devices. The radio interference will have been reduced.

In order to obtain a low HF impedance, use the fastening bolts of the devices as HF connection to the rear plate. It is necessary to remove insulating paint or similar from the fastening points.

### 3.3.4 Extra Protection (RCD)

ELCB relays, multiple protective earthing or earthing can be used as extra protection, provided that local safety regulations are complied with.

In the case of an earth fault, a DC component may develop in the fault current.

If ELCB relays are used, local regulations must be observed. Relays must be suitable for protection of 3-phase equipment with a bridge rectifier and for a brief discharge on power-up.

See also *Special Conditions* in the Design Guide, MG33BXYY.

### 3.3.5 RFI Switch

#### Mains supply isolated from earth

If the frequency converter is supplied from an isolated mains source ( IT mains, floating delta and grounded delta) or TT/TN-S mains with grounded leg, the RFI switch is recommended to be turned off (OFF) <sup>1)</sup> via *14-50 RFI Filter* on the frequency converter and *14-50 RFI Filter* on the filter. For further reference, see IEC 364-3. In case optimum EMC performance is needed, parallel motors are connected

or the motor cable length is above 25 m, it is recommended to set *14-50 RFI Filter* to [ON].

<sup>1)</sup> Not available for 525-600/690 V frequency converters. In OFF, the internal RFI capacities (filter capacitors) between the chassis and the intermediate circuit are cut off to avoid damage to the intermediate circuit and to reduce the earth capacity currents (according to IEC 61800-3).

Please also refer to the application note *VLT on IT mains, MN90CX02*. It is important to use isolation monitors that are capable for use together with power electronics (IEC 61557-8).

### 3.3.6 Torque

When tightening all electrical connections it is important to tighten with the correct torque. Too low or too high torque results in a poor electrical connection. Use a torque wrench to ensure correct torque.

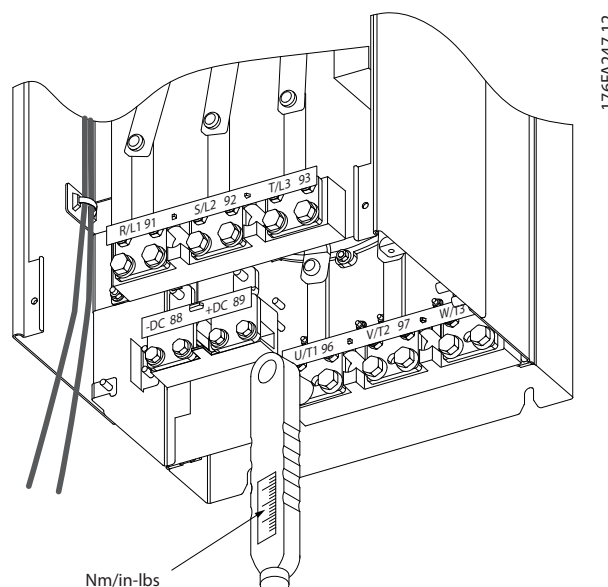

Illustration 3.31 Always use a torque wrench to tighten the bolts.

Frame size	Terminal	Torque	Bolt size
F8-F14	Mains Motor	19-40 Nm (168-354 in-lbs)	M10
	Brake Regen	8.5-20.5 Nm (75-181 in-lbs)	M8
		8.5-20.5 Nm (75-181 in-lbs)	M8

Table 3.2 Tightening torques

### 3.3.7 Shielded Cables

#### **WARNING**

Danfoss recommends to use shielded cables between the LCL filter and the AFE unit. Unshielded cables can be between transformer and LCL filter input side.

It is important that shielded and armoured cables are connected in a proper way to ensure the high EMC immunity and low emissions.

The connection can be made using either cable glands or clamps:

- EMC cable glands: Generally available cable glands can be used to ensure an optimum EMC connection.
- EMC cable clamp: Clamps allowing easy connection are supplied with the frequency converter.

### 3.3.8 Motor Cable

The motor must be connected to terminals U/T1/96, V/T2/97, W/T3/98. Earth to terminal 99. All types of three-phase asynchronous standard motors can be used with a frequency converter unit. The factory setting is for clockwise rotation with the frequency converter output connected as follows:

Terminal No.	Function
96, 97, 98, 99	Mains U/T1, V/T2, W/T3 Earth

- Terminal U/T1/96 connected to U-phase
- Terminal V/T2/97 connected to V-phase
- Terminal W/T3/98 connected to W-phase

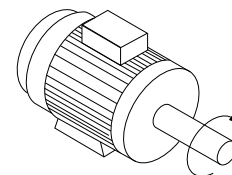
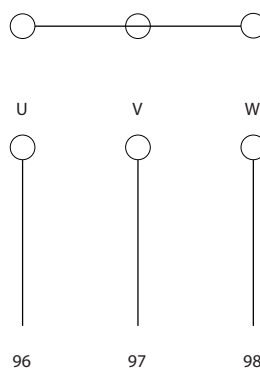

3

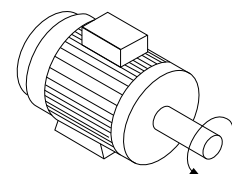
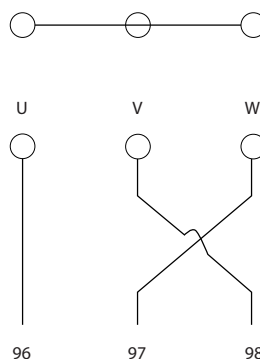

The direction of rotation can be changed by switching two phases in the motor cable or by changing the setting of 4-10 Motor Speed Direction.

Motor rotation check can be performed using 1-28 Motor Rotation Check and following the steps shown in the display.

#### F frame Requirements

**F8/F9 requirements:** The cables are required to be equal length within 10% between the inverter module terminals and the first common point of a phase. The recommended common point is the motor terminals.

**F10/F11 requirements:** Motor phase cable quantities must be multiples of 2, resulting in 2, 4, 6, or 8 (1 cable is not allowed) to obtain equal amount of wires attached to both inverter module terminals. The cables are required to be equal length within 10% between the inverter module terminals and the first common point of a phase. The recommended common point is the motor terminals.

**F12/F13 requirements:** Motor phase cable quantities must be multiples of 3, resulting in 3, 6, 9, or 12 (1, 2, or 3 cables are not allowed) to obtain an equal amount of wires attached to each inverter module terminal. The wires are required to be equal length within 10% between the inverter module terminals and the first common point of a phase. The recommended common point is the motor terminals.

**F14 requirements:** Motor phase cable quantities must be multiples of 4, resulting in 4, 8, 12, or 16 (1, 2, or 3 cables are not allowed) to obtain an equal amount of wires attached to each inverter module terminal. The wires are required to be equal length within 10% between the inverter module terminals and the first common point of a phase. The recommended common point is the motor terminals.

**Output junction box requirements:** The length, minimum 2.5 m, and quantity of cables must be equal from each inverter module to the common terminal in the junction box.

**NOTE**

If a retrofit applications requires unequal amount of wires per phase, consult the factory for requirements and documentation or use the top/bottom entry side cabinet option.

**3.3.9 Brake Cable Drives with Factory Installed Brake Chopper Option**

(Only standard with letter B in position 18 of typecode).

The connection cable to the brake resistor must be screened and the max. length from frequency converter to the DC bar is limited to 25 m (82 ft).

Terminal No.	Function
81, 82	Brake resistor terminals

The connection cable to the brake resistor must be screened. Connect the screen by means of cable clamps to the conductive back plate at the frequency converter and to the metal cabinet of the brake resistor. Size the brake cable cross-section to match the brake torque. See also *Brake Instructions, MI.90.Fx.yy* and *MI.50.Sx.yy* for further information regarding safe installation.

**⚠ WARNING**

Note that voltages up to 1099 V DC, depending on the supply voltage, may occur on the terminals.

**F Frame Requirements**

The brake resistor(s) must be connected to the brake terminals in each inverter module.

**3.3.10 Shielding against Electrical Noise**

Before mounting the mains power cable, mount the EMC metal cover to ensure best EMC performance.

**NOTE**

The EMC metal cover is only included in units with an RFI filter.

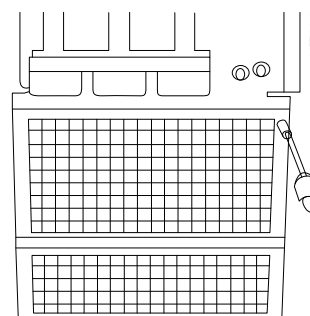

Illustration 3.32 Mounting of EMC shield.

**3.3.11 Mains Connection**

Mains must be connected to terminals 91-1, 92-1, 93-1, 91-2, 92-2 and 93-2 (see *Table 3.3*). Earth is connected to the terminal to the right of terminal 93.

Terminal No.	Function
91-1, 92-1, 93-1	Mains R1/L1-1, S1/L2-1, T1/L3-1
91-2, 92-2, 93-2	Mains R2/L1-2, S2/L2-2, T2/L3-2
94	Earth

**NOTE**

Check the name plate to ensure that the mains voltage of the frequency converter matches the power supply of your plant.

Ensure that the power supply can supply the necessary current to the frequency converter.

If the unit is without built-in fuses, ensure that the appropriate fuses have the correct current rating.



### 3.3.12 External Fan Supply

In case the frequency converter is supplied by DC or if the fan must run independently of the power supply, an external power supply can be applied. The connection is made on the power card.

Terminal No.	Function
100, 101	Auxiliary supply S, T
102, 103	Internal supply S, T

The connector located on the power card provides the connection of line voltage for the cooling fans. The fans are connected from factory to be supplied from a common AC line (jumpers between 100-102 and 101-103). If external supply is needed, the jumpers are removed and the supply is connected to terminals 100 and 101. A 5A fuse should be used for protection. In UL applications this should be LittleFuse KLK-5 or equivalent.

### 3.3.13 Fuses

**Branch circuit protection:**

In order to protect the installation against electrical and fire hazard, all branch circuits in an installation, switch gear, machines etc., must be short-circuited and over-current protected according to national/international regulations.

**Short-circuit protection:**

The frequency converter must be protected against short-circuit to avoid electrical or fire hazard. Danfoss recommends using the fuses mentioned below to protect service personnel and equipment in case of an internal failure in the frequency converter. The frequency converter provides full short-circuit protection in case of a short-circuit on the motor output.

**Over-current protection**

Provide overload protection to avoid fire hazard due to overheating of the cables in the installation. The frequency converter is equipped with an internal over-current

protection that can be used for upstream overload protection (UL-applications excluded). See 4-18 *Current Limit*. Moreover, fuses or circuit breakers can be used to provide the over-current protection in the installation. Over-current protection must always be carried out according to national regulations.

**UL compliance**

The fuses below are suitable for use on a circuit capable of delivering 100,000 Arms (symmetrical), 240 V, or 480 V, or 500 V, or 600 V depending on the frequency converter voltage rating. With the proper fusing the frequency converter Short Circuit Current Rating (SCCR) is 100,000 Arms.

Power size	Frame	Rating		Bussmann	Spare Bussmann	Est. Fuse Power Loss [W]	
		Voltage (UL)	Amperes	P/N	P/N	400 V	460 V
FC 302	Size						
P250T5	F8/F9	700	700	170M4017	176F8591	25	19
P315T5	F8/F9	700	700	170M4017	176F8591	30	22
P355T5	F8/F9	700	700	170M4017	176F8591	38	29
P400T5	F8/F9	700	700	170M4017	176F8591	3500	2800
P450T5	F10/F11	700	900	170M6013	176F8592	3940	4925
P500T5	F10/F11	700	900	170M6013	176F8592	2625	2100
P560T5	F10/F11	700	900	170M6013	176F8592	3940	4925
P630T5	F10/F11	700	1500	170M6018	176F8592	45	34
P710T5	F12/F13	700	1500	170M6018	176F9181	60	45
P800T5	F12/F13	700	1500	170M6018	176F9181	83	63

Table 3.3 Line Fuses, 380-500 V

Power size	Frame	Rating		Bussmann	Spare Bussmann	Est. Fuse Power Loss [W]	
		Voltage (UL)	Amperes	P/N	P/N	600 V	690 V
FC 302	Size						
P355T7	F8/F9	700	630	170M4016	176F8335	13	10
P400T7	F8/F9	700	630	170M4016	176F8335	17	13
P500T7	F8/F9	700	630	170M4016	176F8335	22	16
P560T7	F8/F9	700	630	170M4016	176F8335	24	18
P630T7	F10/F11	700	900	170M6013	176F8592	26	20
P710T7	F10/F11	700	900	170M6013	176F8592	35	27
P800T7	F10/F11	700	900	170M6013	176F8592	44	33
P900T7	F12/F13	700	1500	170M6018	176F9181	26	20
P1M0T7	F12/F13	700	1500	170M6018	176F9181	37	28
P1M2T7	F12/F13	700	1500	170M6018	176F9181	47	36
P1M4T7	F14	700	1500	170M6018	176F9181	47	36

Table 3.4 Line Fuses, 525-690 V

Size/Type	Bussmann PN*	Rating	Siba
P450	170M8611	1100 A, 1000 V	20 781 32.1000
P500	170M8611	1100 A, 1000 V	20 781 32.1000
P560	170M6467	1400 A, 700 V	20 681 32.1400
P630	170M6467	1400 A, 700 V	20 681 32.1400
P710	170M8611	1100 A, 1000 V	20 781 32.1000
P800	170M6467	1400 A, 700 V	20 681 32.1400

Table 3.5 Inverter module DC Link Fuses, 380-500V

Size/Type	Bussmann PN*	Rating	Siba
P630	170M8611	1100 A, 1000 V	20 781 32. 1000
P710	170M8611	1100 A, 1000 V	20 781 32. 1000
P800	170M8611	1100 A, 1000 V	20 781 32. 1000
P900	170M8611	1100 A, 1000 V	20 781 32. 1000
P1M0	170M8611	1100 A, 1000 V	20 781 32. 1000
P1M2	170M8611	1100 A, 1000 V	20 781 32.1000
P1M4	170M8611	1100 A, 1000 V	20 781 32.1000

Table 3.6 Inverter module DC Link Fuses, 525-690 V

\*170M fuses from Bussmann shown use the -/80 visual indicator, - TN/80 Type T, -/110 or TN/110 Type T indicator fuses of the same size and amperage may be substituted for external use.

Supplementary fuses

	Size/Type	Bussmann PN*	Rating	Alternative Fuses
<b>2.5-4.0 A Fuse</b>	P450-P800, 380-500 V	LPJ-6 SP or SPI	6 A, 600 V	Any listed Class J Dual Element, Time Delay, 6A
	P630-P1M2, 525-690 V	LPJ-10 SP or SPI	10 A, 600 V	Any listed Class J Dual Element, Time Delay, 10 A
<b>4.0-6.3 A Fuse</b>	P450-P800, 380-500 V	LPJ-10 SP or SPI	10 A, 600 V	Any listed Class J Dual Element, Time Delay, 10 A
	P630-P1M2, 525-690 V	LPJ-15 SP or SPI	15 A, 600 V	Any listed Class J Dual Element, Time Delay, 15 A
<b>6.3-10 A Fuse</b>	P450-P800, 380-500 V	LPJ-15 SP or SPI	15 A, 600 V	Any listed Class J Dual Element, Time Delay, 15 A
	P630-P1M2, 525-690 V	LPJ-20 SP or SPI	20 A, 600 V	Any listed Class J Dual Element, Time Delay, 20A
<b>10-16 A Fuse</b>	P450-P800, 380-500 V	LPJ-25 SP or SPI	25 A, 600 V	Any listed Class J Dual Element, Time Delay, 25 A
	P630-P1M2, 525-690 V	LPJ-20 SP or SPI	20 A, 600 V	Any listed Class J Dual Element, Time Delay, 20 A
	P630-P1M4, 525-690 V	LPJ-20 SP or SPI	20 A, 600 V	Any listed Class J Dual Element, Time Delay, 20 A

Table 3.7 Manual Motor Controller Fuses

Frame size	Bussmann PN*	Rating
F8-F14	KTK-4	4 A, 600 V

Table 3.8 SMPS Fuse

Size/Type	Bussmann PN*	LittelFuse	Rating
P315-P800, 380-500 V		KLK-15	15 A, 600 V
P500-P1M2, 525-690 V		KLK-15	15 A, 600 V
P500-P1M4, 525-690 V		KLK-15	15 A, 600 V

Table 3.9 Fan Fuses

Frame size	Bussmann PN*	Rating	Alternative Fuses
F8-F14	LPJ-30 SP or SPI	30 A, 600 V	Any listed Class J Dual Element, Time Delay, 30 A

Table 3.10 30 A Fuse Protected Terminal Fuse

Frame size	Bussmann PN*	Rating	Alternative Fuses
F8-F14	LPJ-6 SP or SPI	6 A, 600 V	Any listed Class J Dual Element, Time Delay, 6 A

Table 3.11 Control Transformer Fuse

Frame size	Bussmann PN*	Rating
F8-F14	GMC-800MA	800 mA, 250 V

Table 3.12 NAMUR Fuse

Frame size	Bussmann PN*	Rating	Alternative Fuses
F8-F14	LP-CC-6	6 A, 600 V	Any listed Class CC, 6 A

Table 3.13 Safety Relay Coil Fuse with Pilz Relay

### 3.3.14 Mains Disconnectors, 12-Pulse

Frame size	Power	Type
<b>380-500 V</b>		
F9	P250	ABB OETL-NF600A
F9	P315	ABB OETL-NF600A
F9	P355	ABB OETL-NF600A
F9	P400	ABB OETL-NF600A
F11	P450	ABB OETL-NF800A
F11	P500	ABB OETL-NF800A
F11	P560	ABB OETL-NF800A
F11	P630	ABB OT800U21
F13	P710	Merlin Gerin NPJF36000S12AAYP
F13	P800	Merlin Gerin NPJF36000S12AAYP
<b>525-690 V</b>		
F9	P355	ABB OT400U12-121
F9	P400	ABB OT400U12-121
F9	P500	ABB OT400U12-121
F9	P560	ABB OT400U12-121
F11	P630	ABB OETL-NF600A
F11	P710	ABB OETL-NF600A
F11	P800	ABB OT800U21
F13	P900	ABB OT800U21
F13	P1M0	Merlin Gerin NPJF36000S12AAYP
F13	P1M2	Merlin Gerin NPJF36000S12AAYP

### 3.3.15 Motor Insulation

For motor cable lengths  $\leq$  the maximum cable length listed in the General Specifications tables, *5.1.1 Cable Lengths and Cross Sections*, the following motor insulation ratings are recommended because the peak voltage can be up to twice the DC link voltage, 2.8 times the mains voltage, due to transmission line effects in the motor cable. If a motor has lower insulation rating, it is recommended to use a dU/dt or sine wave filter.

Nominal Mains Voltage [V]	Motor Insulation [V]
$U_N \leq 420$	Standard $U_{LL} = 1300$
$420 < U_N \leq 500$	Reinforced $U_{LL} = 1600$
$500 < U_N \leq 600$	Reinforced $U_{LL} = 1800$
$600 < U_N \leq 690$	Reinforced $U_{LL} = 2000$

### 3.3.16 Motor Bearing Currents

All motors installed with FC 302 250 kW or higher power drives should have NDE (Non-Drive End) insulated bearings installed to eliminate circulating bearing currents. To minimize DE (Drive End) bearing and shaft currents proper grounding of the frequency converter, motor, driven machine, and motor to the driven machine is required.

#### Standard Mitigation Strategies:

1. Use an insulated bearing
2. Apply rigorous installation procedures
  - Ensure the motor and load motor are aligned
  - Strictly follow the EMC Installation guideline
  - Reinforce the PE so the high frequency impedance is lower in the PE than the input power leads
  - Provide a good high frequency connection between the motor and the frequency converter for instance by screened cable which has a 360° connection in the motor and the frequency converter
  - Make sure that the impedance from frequency converter to building ground is lower than the grounding impedance of the machine. This can be difficult for pumps
  - Make a direct earth connection between the motor and load motor
3. Lower the IGBT switching frequency

4. Modify the inverter waveform, 60° AVM vs. SFAVM
5. Install a shaft grounding system or use an isolating coupling
6. Apply conductive lubrication
7. Use minimum speed settings if possible
8. Try to ensure the line voltage is balanced to ground. This can be difficult for IT, TT, TN-CS or Grounded leg systems
9. Use a dU/dt or sinus filter

### 3.3.17 Brake Resistor Temperature Switch

Torque: 0.5-0.6 Nm (5 in-lbs)  
Screw size: M3

This input can be used to monitor the temperature of an externally connected brake resistor. If the input between 104 and 106 is established, the frequency converter will trip on warning/alarm 27, "Brake IGBT". If the connection is closed between 104 and 105, the frequency converter will trip on warning/alarm 27, "Brake IGBT".

A KLIXON switch must be installed that is 'normally closed'. If this function is not used, 106 and 104 must be short-circuited together.

Normally closed: 104-106 (factory installed jumper)

Normally open: 104-105

Terminal No.	Function
106, 104, 105	Brake resistor temperature switch.

If the temperature of the brake resistor gets too high and the thermal switch drops out, the frequency converter will stop braking. The motor will start coasting.

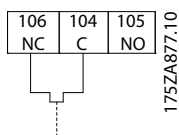

### 3.3.18 Control Cable Routing

Tie down all control wires to the designated control cable routing as shown in the picture. Remember to connect the shields in a proper way to ensure optimum electrical immunity.

#### Fieldbus connection

Connections are made to the relevant options on the control card. For details, see the relevant fieldbus instruction. The cable must be placed in the provided path inside the frequency converter and tied down together with other control wires.

### Installation of 24 V external DC Supply

Torque: 0.5 - 0.6 Nm (5 in-lbs)

Screw size: M3

No.	Function
35 (-), 36 (+)	24 V external DC supply

24 V DC external supply can be used as low-voltage supply to the control card and any option cards installed. This enables full operation of the LCP (including parameter setting) without connection to mains. A warning of low voltage is given when 24 V DC has been connected; however, there is no tripping.

### ⚠ WARNING

Use 24 V DC supply of type PELV to ensure correct galvanic isolation (type PELV) on the control terminals of the frequency converter.

### 3.3.19 Access to Control Terminals

All terminals to the control cables are located beneath the LCP. They are accessed by opening the door of the IP21/54 version or removing the covers of the IP00 version.

### 3.3.20 Electrical Installation, Control Terminals

#### To connect the cable to the terminal:

1. Strip insulation by about 9-10 mm

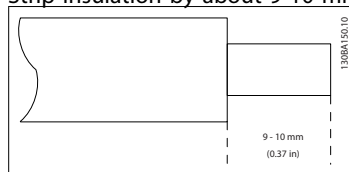

2. Insert a screwdriver<sup>1)</sup> in the square hole.
3. Insert the cable in the adjacent circular hole.

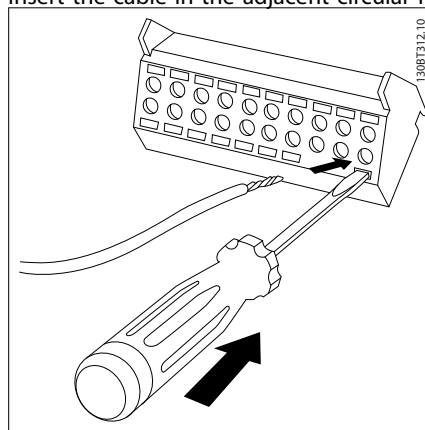

4. Remove the screwdriver. The cable is now mounted in the terminal.

#### To remove the cable from the terminal:

1. Insert a screw driver<sup>1)</sup> in the square hole.

2. Pull out the cable.

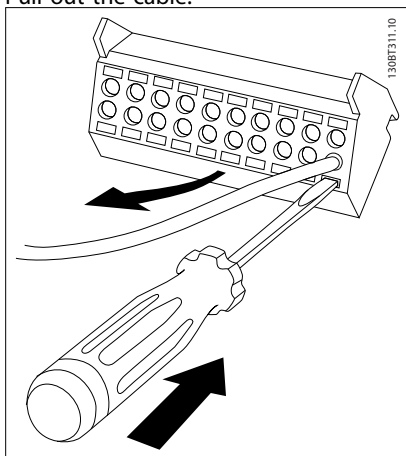

1) Max. 0.4 x 2.5 mm

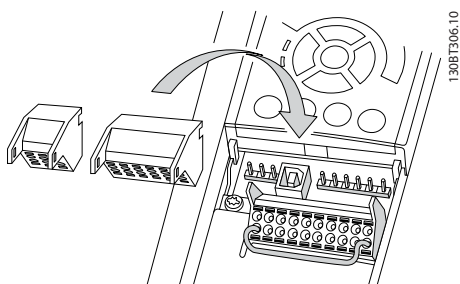

3

### 3.4 Connection Examples

#### 3.4.1 Start/Stop

Terminal 18 = 5-10 Terminal 18 Digital Input [8] Start  
Terminal 27 = 5-12 Terminal 27 Digital Input [0] No operation (Default coast inverse)  
Terminal 37 = Safe stop

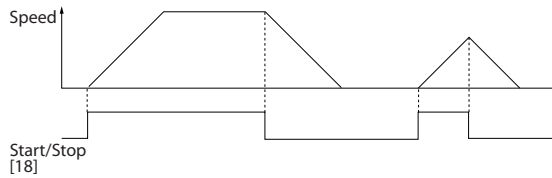
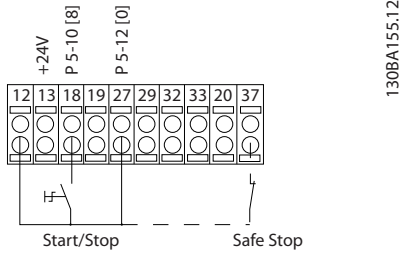

#### 3.4.2 Pulse Start/Stop

Terminal 18 = 5-10 Terminal 18 Digital Input [9] Latched start  
Terminal 27 = 5-12 Terminal 27 Digital Input [6] Stop inverse  
Terminal 37 = Safe stop

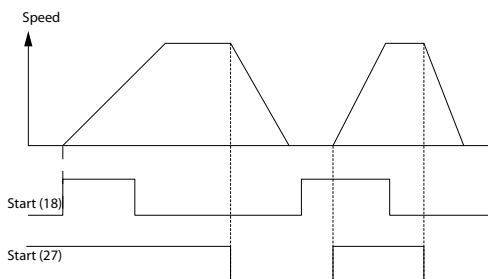
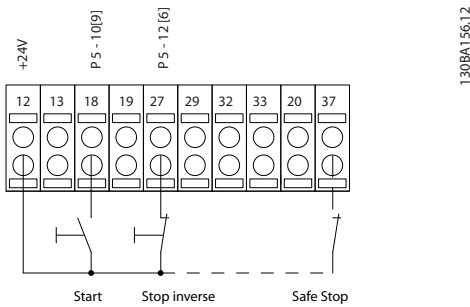

#### 3.4.3 Speed Up/Down

##### Terminals 29/32 = Speed up/down

Terminal 18 = 5-10 Terminal 18 Digital Input Start [9] (default)  
Terminal 27 = 5-12 Terminal 27 Digital Input Freeze reference [19]  
Terminal 29 = 5-13 Terminal 29 Digital Input Speed up [21]  
Terminal 32 = 5-14 Terminal 32 Digital Input Speed down [22]

##### NOTE

Terminal 29 only in FC x02 (x=series type).

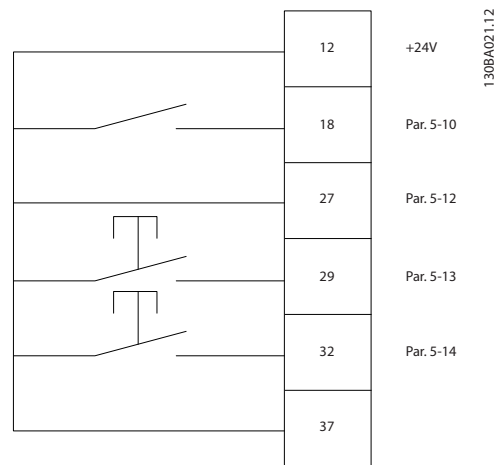

#### 3.4.4 Potentiometer Reference

##### Voltage reference via a potentiometer

Reference Source 1 = [1] Analog input 53 (default)  
Terminal 53, Low Voltage = 0 V  
Terminal 53, High Voltage = 10 V  
Terminal 53, Low Ref./Feedback = 0 RPM  
Terminal 53, High Ref./Feedback = 1500 RPM  
Switch S201 = OFF (U)

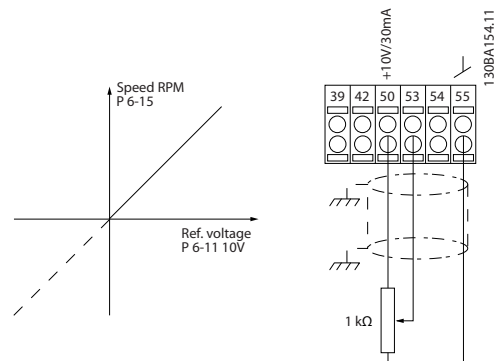



### 3.5.1 Electrical Installation, Control Cables

CONTROL CARD CONNECTION

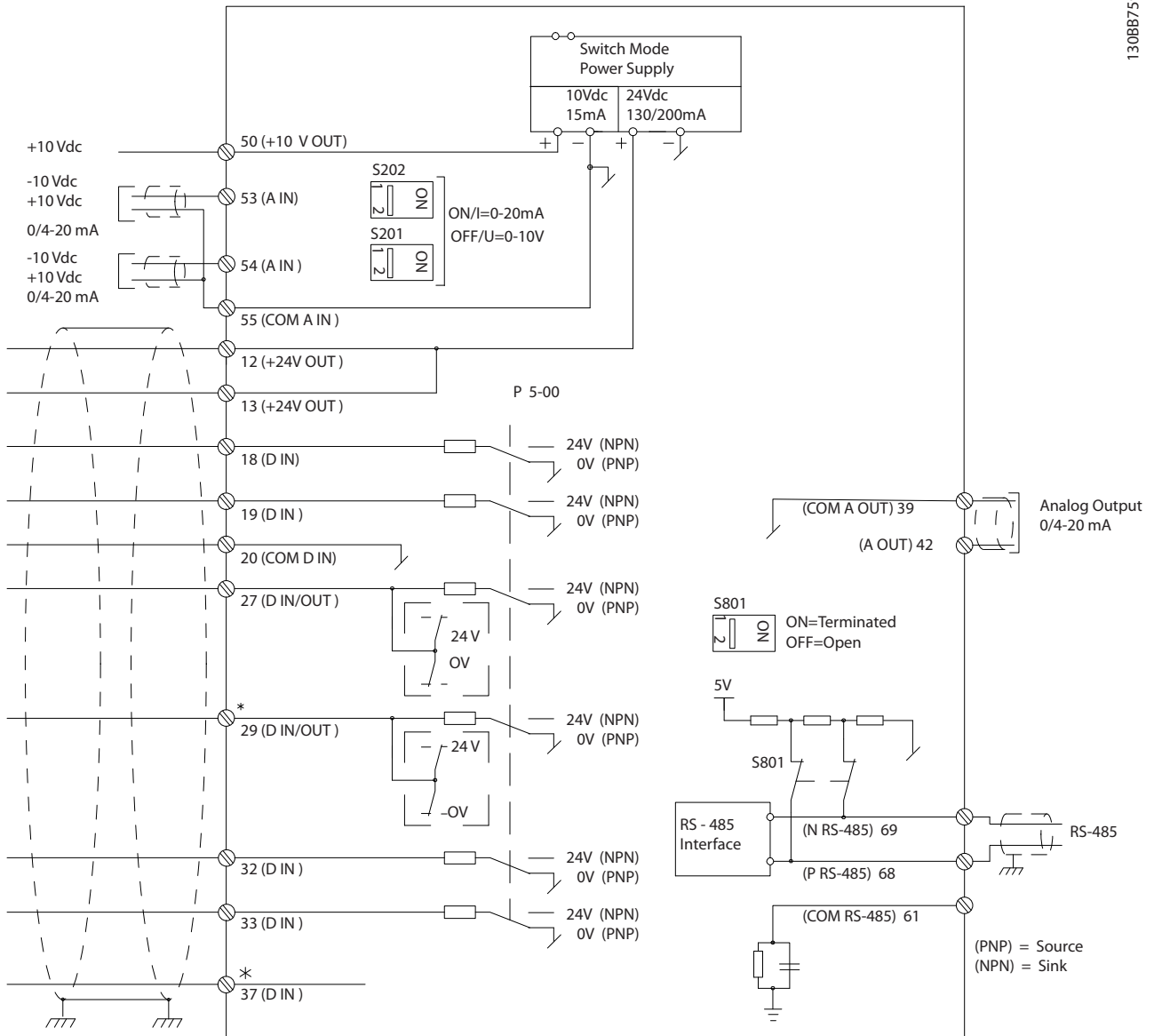

13088759.10

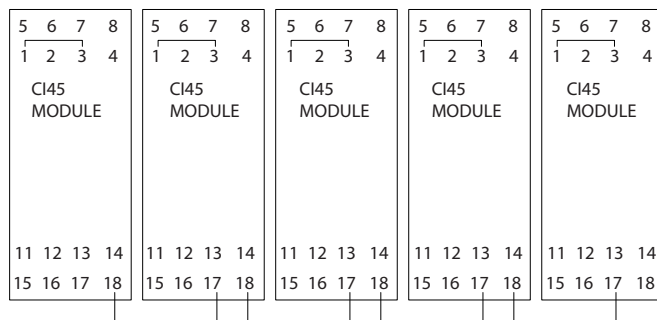

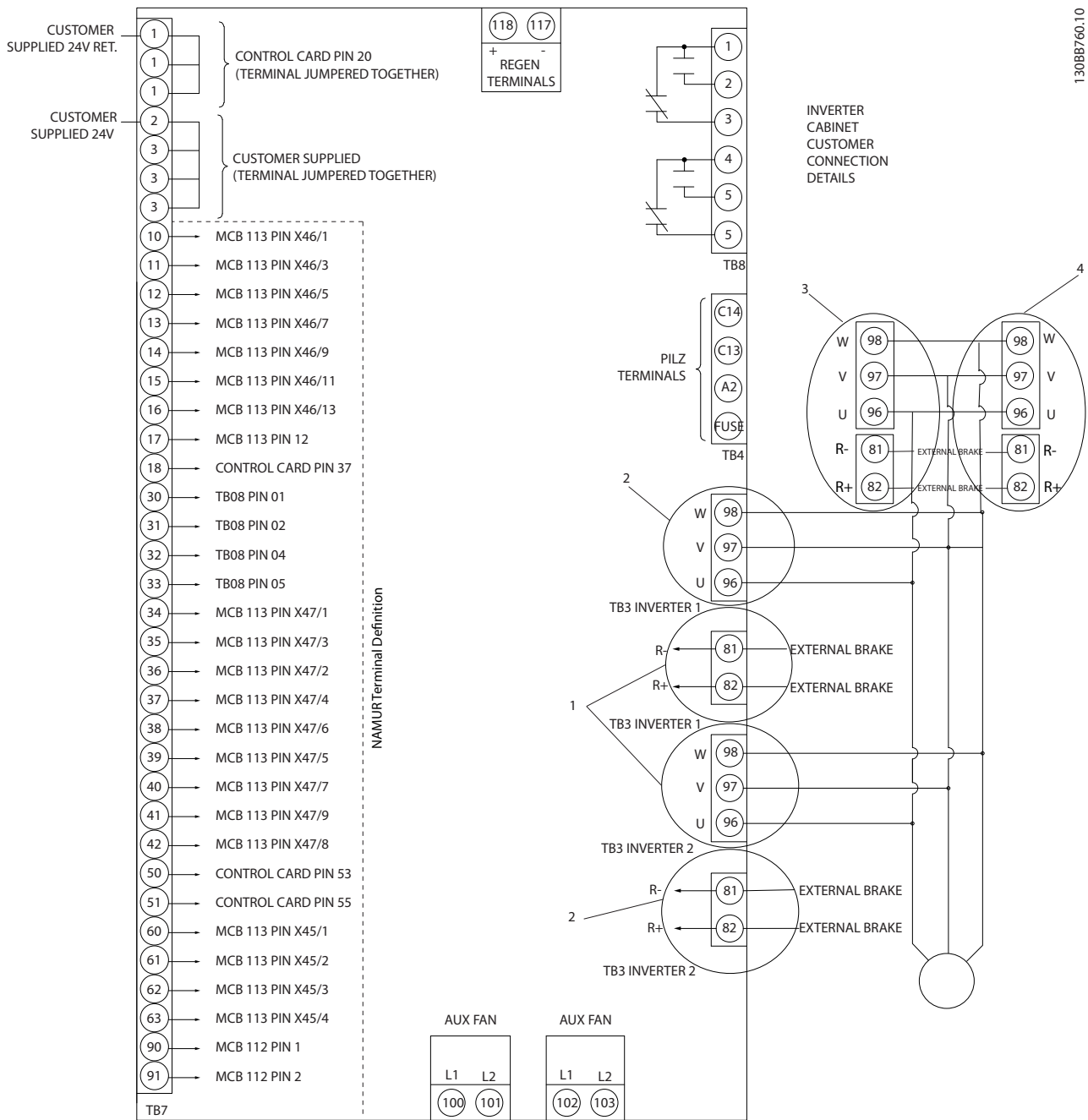

Illustration 3.33 Diagram showing all electrical terminals with NAMUR option shown in dotted line box.

Terminal 37 is the input to be used for Safe Stop. For instructions on Safe Stop installation please refer to the section *Safe Stop Installation* in the Design Guide. See also sections *Safe Stop* and *Safe Stop Installation*.

- 1) F8/F9 = (1) set of terminals.
- 2) F10/F11 = (2) sets of terminals.
- 3) F12/F13 = (3) sets of terminals.
- 4) F14 = (4) sets of terminals.

Very long control cables and analogue signals may in rare cases and depending on installation result in 50/60 Hz earth loops due to noise from mains supply cables.

If this occurs, it may be necessary to break the screen or insert a 100 nF capacitor between screen and chassis.

The digital and analog inputs and outputs must be connected separately to the frequency converter common inputs (terminal 20, 55, 39) to avoid earth currents from both groups to affect other groups. For example, switching on the digital input may disturb the analog input signal.

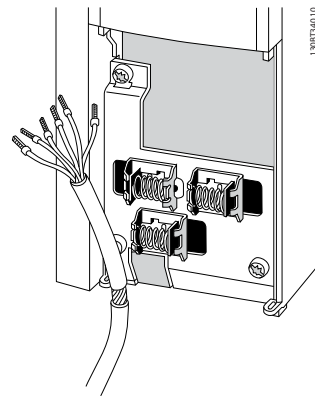

3

**Input polarity of control terminals**

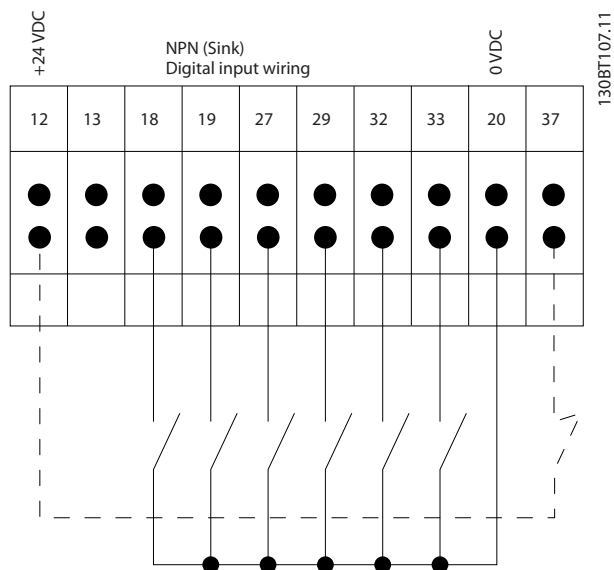
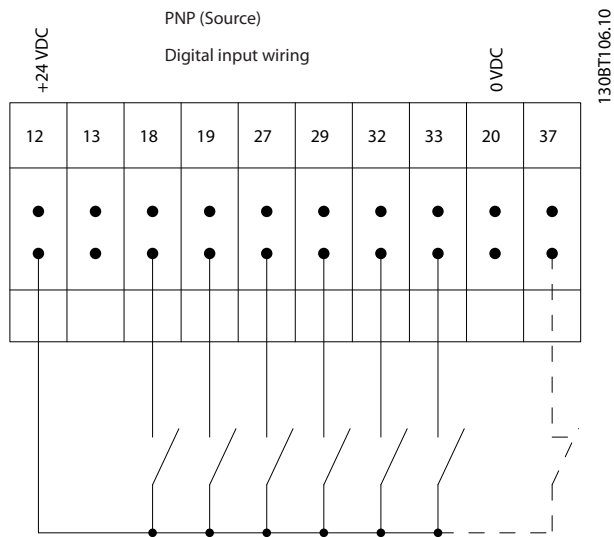

**NOTE**

Control cables must be screened/armoured.

Connect the wires as described in the *VLT® Automation Drive FC 300 Operating Instructions, MG33AXYY*. Remember to connect the shields in a proper way to ensure optimum electrical immunity.

3

### 3.5.2 Switches S201, S202, and S801

Switches S201 (A53) and S202 (A54) are used to select a current (0-20 mA) or a voltage (-10 to 10 V) configuration of the analog input terminals 53 and 54 respectively.

Switch S801 (BUS TER.) can be used to enable termination on the RS-485 port (terminals 68 and 69).

See *Illustration 3.33*.

**Default setting:**

S201 (A53) = OFF (voltage input)

S202 (A54) = OFF (voltage input)

S801 (Bus termination) = OFF

**NOTE**

When changing the function of S201, S202 or S801 be careful not to use force for the switch over. It is recommended to remove the LCP fixture (cradle) when operating the switches. The switches must not be operated with power on the frequency converter.

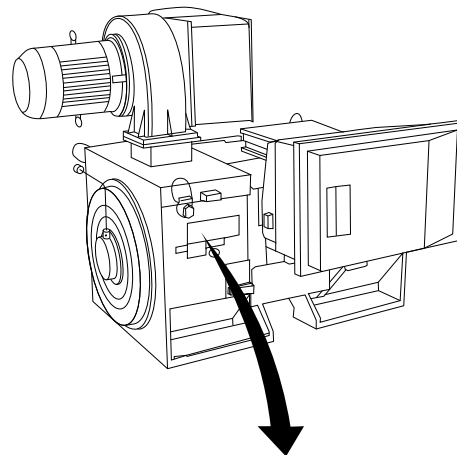
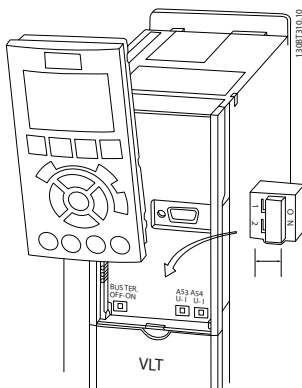

130BA767.10

THREE PHASE INDUCTION MOTOR				
MOD MCV 315E	Nr.	135189 12 04	IL/IN 6.5	
kW 400	PRIMARY			SF 1.15
HP 536	V 690	A 410.6	CONN Y	COS f 0.85 40
mm 1481	V	A	CONN	AMB 40 °C
Hz 50	V	A	CONN	ALT 1000 m
DESIGNN	SECONDARY			RISE 80 °C
DUTY S1	V	A	CONN	ENCLOSURE IP23
INSUL I	EFFICIENCY %	95.8%	100%	95.8% 75% WEIGHT 1.83 ton

⚠ CAUTION

**Step 2. Enter the motor name plate data in this parameter list.**

To access this list first press [Quick Menu] then select "Q2 Quick Setup".

1.	1-20 Motor Power [kW] 1-21 Motor Power [HP]
2.	1-22 Motor Voltage
3.	1-23 Motor Frequency
4.	1-24 Motor Current
5.	1-25 Motor Nominal Speed

### 3.6 Final Set-Up and Test

To test the set-up and ensure that the frequency converter is running, follow these steps.

**Step 1. Locate the motor name plate**

**NOTE**

The motor is either star- (Y) or delta- connected (Δ). This information is located on the motor name plate data.

**Step 3. Activate the Automatic Motor Adaptation (AMA)**

Performing an AMA will ensure optimum performance. The AMA measures the values from the motor model equivalent diagram.

1. Connect terminal 37 to terminal 12 (if terminal 37 is available).
2. Connect terminal 27 to terminal 12 or set 5-12 Terminal 27 Digital Input to 'No function' (5-12 Terminal 27 Digital Input [0])
3. Activate the AMA 1-29 Automatic Motor Adaptation (AMA).
4. Choose between complete or reduced AMA. If a Sine-wave filter is mounted, run only the reduced AMA, or remove the Sine-wave filter during the AMA procedure.
5. Press [OK]. The display shows "Press [Hand on] to start".

6. Press [Hand on]. A progress bar indicates if the AMA is in progress.

#### Stop the AMA during operation

1. Press [Off] - the frequency converter enters into alarm mode and the display shows that the AMA was terminated by the user.

#### Successful AMA

1. The display shows "Press [OK] to finish AMA".
2. Press [OK] to exit the AMA state.

#### Unsuccessful AMA

1. The frequency converter enters into alarm mode. A description of the alarm can be found in the *Warnings and Alarms* chapter.
2. "Report Value" in the [Alarm Log] shows the last measuring sequence carried out by the AMA, before the frequency converter entered alarm mode. This number along with the description of the alarm will assist you in troubleshooting. If contacting Danfoss for service, make sure to mention number and alarm description.

- The brake is released when the motor current exceeds the preset value in *2-20 Release Brake Current*.
- The brake is engaged when the output frequency is less than the frequency set in *2-21 Activate Brake Speed [RPM]* or *2-22 Activate Brake Speed [Hz]*, and only if the frequency converter carries out a stop command.

If the frequency converter is in alarm mode or in an over-voltage situation, the mechanical brake immediately cuts in.

## NOTE

**Unsuccessful AMA is often caused by incorrectly registered motor name plate data or a too big difference between the motor power size and the frequency converter power size.**

### Step 4. Set speed limit and ramp time

*3-02 Minimum Reference*

*3-03 Maximum Reference*

#### Set up the desired limits for speed and ramp time

*4-11 Motor Speed Low Limit [RPM]* or *4-12 Motor Speed Low Limit [Hz]*

*4-13 Motor Speed High Limit [RPM]* or *4-14 Motor Speed High Limit [Hz]*

*3-41 Ramp 1 Ramp up Time*

*3-42 Ramp 1 Ramp Down Time*

## 3.7 Additional Connections

### 3.7.1 Mechanical Brake Control

**In hoisting/lowering applications, it is necessary to be able to control an electro-mechanical brake:**

- Control the brake using any relay output or digital output (terminal 27 or 29).
- Keep the output closed (voltage-free) as long as the frequency converter is unable to 'support' the motor, for example due to the load being too heavy.
- Select *[32] Mechanical brake control* in parameter group 5-4\* for applications with an electro-mechanical brake.

3

### 3.7.2 Parallel Connection of Motors

The frequency converter can control several parallel-connected motors. The total current consumption of the motors must not exceed the rated output current  $I_{M,N}$  for the frequency converter.

#### NOTE

Installations with cables connected in a common joint as in *Illustration 3.34*, is only recommended for short cable lengths.

#### NOTE

When motors are connected in parallel, *1-29 Automatic Motor Adaptation (AMA)* cannot be used.

#### NOTE

The electronic thermal relay (ETR) of the frequency converter cannot be used as motor protection for the individual motor in systems with parallel-connected motors. Provide further motor protection by e.g. thermistors in each motor or individual thermal relays (circuit breakers are not suitable as protection).

Problems may arise at start and at low RPM values if motor sizes are widely different because small motors' relatively high ohmic resistance in the stator calls for a higher voltage at start and at low RPM values.

### 3.7.3 Motor Thermal Protection

The electronic thermal relay in the frequency converter has received UL-approval for single motor protection, when *1-90 Motor Thermal Protection* is set for *ETR Trip* and *1-24 Motor Current* is set to the rated motor current (see motor name plate).

For thermal motor protection it is also possible to use the MCB 112 PTC Thermistor Card option. This card provides ATEX certificate to protect motors in explosion hazardous areas, Zone 1/21 and Zone 2/22. When *1-90 Motor Thermal Protection* is set to [20] ATEX ETR is combined with the use of MCB 112, it is possible to control an Ex-e motor in explosion hazardous areas. Consult the programming guide for details on how to set up the frequency converter for safe operation of Ex-e motors.

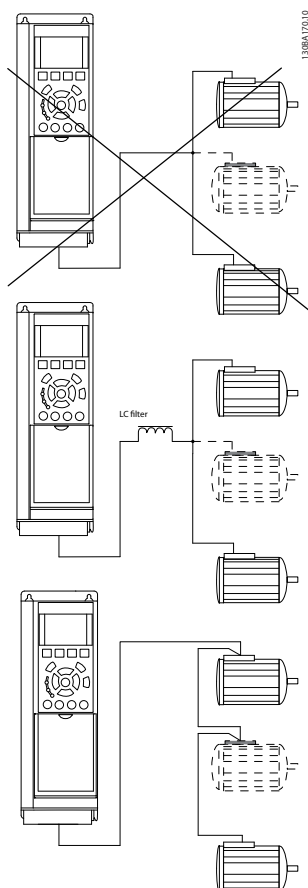

Illustration 3.34

## 4 How to Programme

### 4.1.1 How to Programme on the Graphical LCP

The control panel is divided into four functional groups

1. Graphical display with Status lines.
2. Menu keys and indicator lights - changing parameters and switching between display functions.
3. Navigation keys and indicator lights (LEDs).
4. Operation keys and indicator lights (LEDs).

All data is displayed in a graphical LCP display, which can show up to five items of operating data while displaying [Status].

#### Display lines

- a. **Status line:** Status messages displaying icons and graphic.
- b. **Line 1-2:** Operator data lines displaying data defined or chosen by the user. By pressing the [Status] key, up to one extra line can be added.
- c. **Status line:** Status messages displaying text.

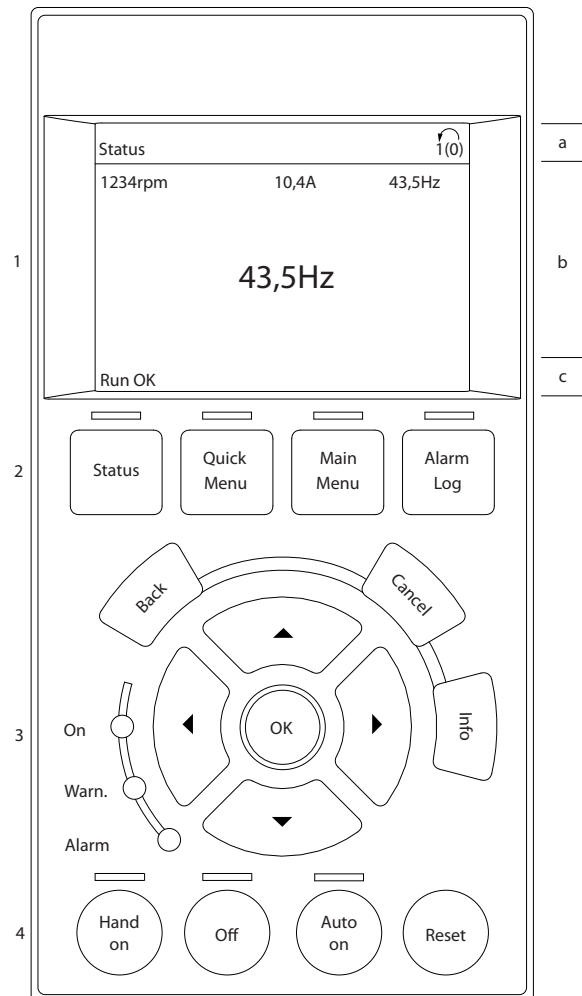

### 4.1.2 Initial Commissioning

The easiest way of carrying out the initial commissioning is by using the [Quick Menu] key and follow the quick set-up procedure using LCP 102 (read table from left to right). The example applies to open loop applications.

4

Press				
		Q2 Quick Menu		
0-01 <i>Language</i>		Set language		
1-20 <i>Motor Power [kW]</i>		Set Motor nameplate power		
1-22 <i>Motor Voltage</i>		Set Nameplate voltage		
1-23 <i>Motor Frequency</i>		Set Nameplate frequency		
1-24 <i>Motor Current</i>		Set Nameplate current		
1-25 <i>Motor Nominal Speed</i>		Set Nameplate speed in RPM		
5-12 <i>Terminal 27 Digital Input</i>		If terminal default is <i>Coast inverse</i> it is possible to change this setting to <i>No function</i> . No connection to terminal 27 is then needed for running AMA		
1-29 <i>Automatic Motor Adaptation (AMA)</i>		Set desired AMA function. Enable complete AMA is recommended		
3-02 <i>Minimum Reference</i>		Set the minimum speed of the motor shaft		
3-03 <i>Maximum Reference</i>		Set the maximum speed of the motor shaft		
3-41 <i>Ramp 1 Ramp up Time</i>		Set the ramping up time with reference to synchronous motor speed, $n_s$		
3-42 <i>Ramp 1 Ramp Down Time</i>		Set the ramping down time with reference to synchronous motor speed, $n_s$		
3-13 <i>Reference Site</i>		Set the site from where the reference must work		



## 4.2 Quick Setup

0-01 Language		
Option:	Function:	
	Defines the language to be used in the display. The frequency converter can be delivered with 4 different language packages. English and German are included in all packages. English cannot be erased or manipulated.	
[0] *	English	Part of Language packages 1 - 4
[1]	Deutsch	Part of Language packages 1 - 4
[2]	Francais	Part of Language package 1
[3]	Dansk	Part of Language package 1
[4]	Spanish	Part of Language package 1
[5]	Italiano	Part of Language package 1
	Svenska	Part of Language package 1
[7]	Nederlands	Part of Language package 1
[10]	Chinese	Part of Language package 2
	Suomi	Part of Language package 1
[22]	English US	Part of Language package 4
	Greek	Part of Language package 4
	Bras.port	Part of Language package 4
	Slovenian	Part of Language package 3
	Korean	Part of Language package 2
	Japanese	Part of Language package 2
	Turkish	Part of Language package 4
	Trad.Chinese	Part of Language package 2
	Bulgarian	Part of Language package 3
	Srpski	Part of Language package 3
	Romanian	Part of Language package 3
	Magyar	Part of Language package 3
	Czech	Part of Language package 3
	Polski	Part of Language package 4
	Russian	Part of Language package 3
	Thai	Part of Language package 2
	Bahasa Indonesia	Part of Language package 2
[52]	Hrvatski	

1-20 Motor Power [kW]		
Range:	Function:	
Application dependent*	[Application dependant]	

1-22 Motor Voltage		
Range:	Function:	
Size related*	[ 10. - 1000. V]	Enter the nominal motor voltage according to the motor nameplate data. The default value corresponds to the nominal rated output of the unit. This parameter cannot be adjusted while the motor is running.

1-23 Motor Frequency		
Range:	Function:	
Application dependent*	[20 - 1000 Hz]	Min - Max motor frequency: 20-1000 Hz. Select the motor frequency value from the motor nameplate data. If a value different from 50 Hz or 60 Hz is selected, it is necessary to adapt the load independent settings in <i>1-50 Motor Magnetisation at Zero Speed</i> to <i>1-53 Model Shift Frequency</i> . For 87 Hz operation with 230/400 V motors, set the nameplate data for 230 V/50 Hz. Adapt <i>4-13 Motor Speed High Limit [RPM]</i> and <i>3-03 Maximum Reference</i> to the 87 Hz application.

1-24 Motor Current		
Range:	Function:	
Size related*	[ 0.10 - 10000.00 A]	Enter the nominal motor current value from the motor nameplate data. This data is used for calculating motor torque, motor thermal protection etc.

### NOTE

This parameter cannot be changed while the motor is running.

1-25 Motor Nominal Speed		
Range:	Function:	
Size related*	[100 - 60000 RPM]	Enter the nominal motor speed value from the motor nameplate data. This data is used for calculating automatic motor compensations.

### NOTE

This parameter cannot be changed while the motor is running.

**5-12 Terminal 27 Digital Input**

**Option: Function:**

	Select the function from the available digital input range.
No operation	[0]
Reset	[1]
Coast inverse	[2]
Coast and reset inverse	[3]
Quick stop inverse	[4]
DC-brake inverse	[5]
Stop inverse	[6]
Start	[8]
Latched start	[9]
Reversing	[10]
Start reversing	[11]
Enable start forward	[12]
Enable start reverse	[13]
Jog	[14]
Preset ref bit 0	[16]
Preset ref bit 1	[17]
Preset ref bit 2	[18]
Freeze reference	[19]
Freeze output	[20]
Speed up	[21]
Speed down	[22]
Set-up select bit 0	[23]
Set-up select bit 1	[24]
Catch up	[28]
Slow down	[29]
Pulse input	[32]
Ramp bit 0	[34]
Ramp bit 1	[35]
Mains failure inverse	[36]
DigiPot Increase	[55]
DigiPot Decrease	[56]
DigiPot Clear	[57]
Reset Counter A	[62]
Reset Counter B	[65]

**1-29 Automatic Motor Adaptation (AMA)**

**Option: Function:**

	The AMA function optimizes dynamic motor performance by automatically optimizing the advanced motor parameters (par. 1-30 to par. 1-35) at motor standstill. Activate the AMA function by pressing [Hand on] after selecting [1] <i>Enable complete AMA</i> or [2] <i>Enable reduced AMA</i> . See also the section <i>Automatic Motor Adaptation</i> . After a normal sequence, the display will read: "Press [OK] to finish AMA". After pressing [OK], the frequency converter is ready for operation.
--	---

**1-29 Automatic Motor Adaptation (AMA)**

**Option: Function:**

		This parameter cannot be adjusted while the motor is running.
[0] *	OFF	
[1]	Enable complete AMA	Performs AMA of the stator resistance $R_s$ , the rotor resistance $R_r$ , the stator leakage reactance $X_1$ , the rotor leakage reactance $X_2$ and the main reactance $X_h$ . <b>FC 301:</b> The complete AMA does not include $X_h$ measurement for FC 301. Instead, the $X_h$ value is determined from the motor database. <i>1-35 Main Reactance (Xh)</i> may be adjusted to obtain optimal start performance.
[2]	Enable reduced AMA	Performs a reduced AMA of the stator resistance $R_s$ in the system only. Select this option if an LC filter is used between the frequency converter and the motor.

**Note:**

- For the best adaptation of the frequency converter, run AMA on a cold motor.
- AMA cannot be performed while the motor is running.
- AMA cannot be performed on permanent magnet motors.

It is important to set motor parameter group 1-2\* correctly, since these form part of the AMA algorithm. An AMA must be performed to achieve optimum dynamic motor performance. It may take up to 10 min, depending on the power rating of the motor.

Avoid generating external torque during AMA.

If one of the settings in parameter group 1-2\* is changed, par. 1-30 to par. 1-39, the advanced motor parameters, will return to default setting.

**3-02 Minimum Reference**

<b>Range:</b>	<b>Function:</b>
Application dependent*	[Application dependant]

**3-03 Maximum Reference**

<b>Range:</b>	<b>Function:</b>
Application dependent*	[Application dependant]
	Enter the Maximum Reference. The Maximum Reference is the highest value obtainable by summing all references.  <b>The Maximum Reference unit matches:</b> <ul style="list-style-type: none"> <li>• The choice of configuration in <i>1-00 Configuration Mode</i>: for [1] <i>Speed closed</i></li> </ul>

3-03 Maximum Reference		
Range:		Function:
		<i>loop</i> , RPM; for [2] Torque, Nm. <ul style="list-style-type: none"> <li>The unit selected in 3-00 Reference Range.</li> </ul>

3-41 Ramp 1 Ramp up Time		
Range:		Function:
Application dependent*	[Application dependant]	

3-42 Ramp 1 Ramp Down Time		
Range:		Function:
Application dependent*	[Application dependant]	Enter the ramp-down time, i.e. the deceleration time from the synchronous motor speed $n_s$ to 0 RPM. Choose a ramp-down time such that no over-voltage arises in the inverter due to regenerative operation of the motor, and such that the generated current does not exceed the current limit set in 4-18 Current Limit. The value 0.00 corresponds to 0.01 s in speed mode. See ramp-up time in 3-41 Ramp 1 Ramp up Time.  $Par. 3 - 42 = \frac{t_{dec} [s] \times n_s [RPM]}{ref [RPM]}$

### 4.3 Parameter Lists

Changes during operation

“TRUE” means that the parameter can be changed while the frequency converter is in operation and “FALSE” means that it must be stopped before a change can be made.

4-Set-up

'All set-up': the parameters can be set individually in each of the four set-ups, i.e. one single parameter can have four different data values.

'1 set-up': data value will be the same in all set-ups.

Conversion index

This number refers to a conversion figure used when writing or reading to and from the frequency converter.

Conv. index	100	67	6	5	4	3	2	1	0	-1	-2	-3	-4	-5	-6
Conv. factor	1	1/60	1000000	100000	10000	1000	100	10	1	0.1	0.01	0.001	0.0001	0.00001	0.000001

Data type	Description	Type
2	Integer 8	Int8
3	Integer 16	Int16
4	Integer 32	Int32
5	Unsigned 8	UInt8
6	Unsigned 16	UInt16
7	Unsigned 32	UInt32
9	Visible String	VisStr
33	Normalized value 2 bytes	N2
35	Bit sequence of 16 boolean variables	V2
54	Time difference w/o date	TimD

See the *VLT® Automation Drive FC 300 Design Guide, MG33BXYY* for further information about data types 33, 35 and 54.

Parameters for the frequency converter are grouped into various parameter groups for easy selection of the correct parameters for optimized operation of the frequency converter.

0-\*\* Operation and Display parameters for basic frequency converter settings

1-\*\* Load and Motor parameters, includes all load and motor related parameters

2-\*\* Brake parameters

3-\*\* References and ramping parameters, includes DigiPot function

4-\*\* Limits Warnings, setting of limits and warning parameters

5-\*\* Digital inputs and outputs, includes relay controls

6-\*\* Analog inputs and outputs

7-\*\* Controls, setting parameters for speed and process controls

8-\*\* Communication and option parameters, setting of FC RS485 and FC USB port parameters.

9-\*\* Profibus parameters

10-\*\* DeviceNet and CAN Fieldbus parameters

12-\*\* Ethernet parameters

13-\*\* Smart Logic Control parameters

14-\*\* Special function parameters

15-\*\* Drive information parameters

16-\*\* Read out parameters

17-\*\* Encoder Option parameters

18-\*\* Data Readouts 2

30-\*\* Special Features

32-\*\* MCO 305 Basic parameters

33-\*\* MCO 305 Advanced parameters

34-\*\* MCO Data Readout parameters

35-\*\* Sensor Input Option

## 4.3.1 0-\*\* Operation/Display

Par. No. #	Parameter description	Default value	4-set-up	FC 302 only	Change during operation	Conversion index	Type
<b>0-0* Basic Settings</b>							
0-01	Language	[0] English	1 set-up		TRUE	-	Uint8
0-02	Motor Speed Unit	[0] RPM	2 set-ups		FALSE	-	Uint8
0-03	Regional Settings	[0] International	2 set-ups		FALSE	-	Uint8
0-04	Operating State at Power-up (Hand)	[1] Forced stop, ref=old	All set-ups		TRUE	-	Uint8
0-09	Performance Monitor	0.0 %	All set-ups		TRUE	-1	Uint16
<b>0-1* Set-up Operations</b>							
0-10	Active Set-up	[1] Set-up 1	1 set-up		TRUE	-	Uint8
0-11	Edit Set-up	[1] Set-up 1	All set-ups		TRUE	-	Uint8
0-12	This Set-up Linked to	[0] Not linked	All set-ups		FALSE	-	Uint8
0-13	Readout: Linked Set-ups	0 N/A	All set-ups		FALSE	0	Uint16
0-14	Readout: Edit Set-ups / Channel	0 N/A	All set-ups		TRUE	0	Int32
0-15	Readout: actual setup	0 N/A	All set-ups		FALSE	0	Uint8
<b>0-2* LCP Display</b>							
0-20	Display Line 1.1 Small	1617	All set-ups		TRUE	-	Uint16
0-21	Display Line 1.2 Small	1614	All set-ups		TRUE	-	Uint16
0-22	Display Line 1.3 Small	1610	All set-ups		TRUE	-	Uint16
0-23	Display Line 2 Large	1613	All set-ups		TRUE	-	Uint16
0-24	Display Line 3 Large	1602	All set-ups		TRUE	-	Uint16
0-25	My Personal Menu	App.Dependent	1 set-up		TRUE	0	Uint16
<b>0-3* LCP Custom Readout</b>							
0-30	Unit for User-defined Readout	[0] None	All set-ups		TRUE	-	Uint8
0-31	Min Value of User-defined Readout	0.00 CustomReadoutUnit	All set-ups		TRUE	-2	Int32
0-32	Max Value of User-defined Readout	100.00 CustomReadoutUnit	All set-ups		TRUE	-2	Int32
0-37	Display Text 1	0 N/A	1 set-up		TRUE	0	VisStr[25]
0-38	Display Text 2	0 N/A	1 set-up		TRUE	0	VisStr[25]
0-39	Display Text 3	0 N/A	1 set-up		TRUE	0	VisStr[25]
<b>0-4* LCP Keypad</b>							
0-40	[Hand on] Key on LCP	null	All set-ups		TRUE	-	Uint8
0-41	[Off] Key on LCP	null	All set-ups		TRUE	-	Uint8
0-42	[Auto on] Key on LCP	null	All set-ups		TRUE	-	Uint8
0-43	[Reset] Key on LCP	null	All set-ups		TRUE	-	Uint8
0-44	[Off/Reset] Key on LCP	null	All set-ups		TRUE	-	Uint8
0-45	[Drive Bypass] Key on LCP	null	All set-ups		TRUE	-	Uint8
<b>0-5* Copy/Save</b>							
0-50	LCP Copy	[0] No copy	All set-ups		FALSE	-	Uint8
0-51	Set-up Copy	[0] No copy	All set-ups		FALSE	-	Uint8
<b>0-6* Password</b>							
0-60	Main Menu Password	100 N/A	1 set-up		TRUE	0	Int16
0-61	Access to Main Menu w/o Password	[0] Full access	1 set-up		TRUE	-	Uint8
0-65	Quick Menu Password	200 N/A	1 set-up		TRUE	0	Int16
0-66	Access to Quick Menu w/o Password	[0] Full access	1 set-up		TRUE	-	Uint8
0-67	Bus Password Access	0 N/A	All set-ups		TRUE	0	Uint16

## 4.3.2 1-\*\* Load/Motor

4

Par. No. #	Parameter description	Default value	4-set-up	FC 302 only	Change during operation	Conversion index	Type
<b>1-0* General Settings</b>							
1-00	Configuration Mode	null	All set-ups		TRUE	-	Uint8
1-01	Motor Control Principle	null	All set-ups		FALSE	-	Uint8
1-02	Flux Motor Feedback Source	[1] 24V encoder	All set-ups		FALSE	-	Uint8
1-03	Torque Characteristics	[0] Constant torque	All set-ups	x	TRUE	-	Uint8
1-04	Overload Mode	[0] High torque	All set-ups		FALSE	-	Uint8
1-05	Local Mode Configuration	[2] As mode par 1-00	All set-ups		TRUE	-	Uint8
1-06	Clockwise Direction	[0] Normal	All set-ups		FALSE	-	Uint8
<b>1-1* Motor Selection</b>							
1-10	Motor Construction	[0] Asynchron	All set-ups		FALSE	-	Uint8
<b>1-2* Motor Data</b>							
1-20	Motor Power [kW]	App.Dependent	All set-ups		FALSE	1	Uint32
1-21	Motor Power [HP]	App.Dependent	All set-ups		FALSE	-2	Uint32
1-22	Motor Voltage	App.Dependent	All set-ups		FALSE	0	Uint16
1-23	Motor Frequency	App.Dependent	All set-ups		FALSE	0	Uint16
1-24	Motor Current	App.Dependent	All set-ups		FALSE	-2	Uint32
1-25	Motor Nominal Speed	App.Dependent	All set-ups		FALSE	67	Uint16
1-26	Motor Cont. Rated Torque	App.Dependent	All set-ups		FALSE	-1	Uint32
1-29	Automatic Motor Adaptation (AMA)	[0] Off	All set-ups		FALSE	-	Uint8
<b>1-3* Adv. Motor Data</b>							
1-30	Stator Resistance (Rs)	App.Dependent	All set-ups		FALSE	-4	Uint32
1-31	Rotor Resistance (Rr)	App.Dependent	All set-ups		FALSE	-4	Uint32
1-33	Stator Leakage Reactance (X1)	App.Dependent	All set-ups		FALSE	-4	Uint32
1-34	Rotor Leakage Reactance (X2)	App.Dependent	All set-ups		FALSE	-4	Uint32
1-35	Main Reactance (Xh)	App.Dependent	All set-ups		FALSE	-4	Uint32
1-36	Iron Loss Resistance (Rfe)	App.Dependent	All set-ups		FALSE	-3	Uint32
1-37	d-axis Inductance (Ld)	App.Dependent	All set-ups	x	FALSE	-4	Int32
1-39	Motor Poles	App.Dependent	All set-ups		FALSE	0	Uint8
1-40	Back EMF at 1000 RPM	App.Dependent	All set-ups	x	FALSE	0	Uint16
1-41	Motor Angle Offset	0 N/A	All set-ups		FALSE	0	Int16
<b>1-5* Load Indep. Setting</b>							
1-50	Motor Magnetisation at Zero Speed	100 %	All set-ups		TRUE	0	Uint16
1-51	Min Speed Normal Magnetising [RPM]	App.Dependent	All set-ups		TRUE	67	Uint16
1-52	Min Speed Normal Magnetising [Hz]	App.Dependent	All set-ups		TRUE	-1	Uint16
1-53	Model Shift Frequency	App.Dependent	All set-ups	x	FALSE	-1	Uint16
1-54	Voltage reduction in fieldweakening	0 V	All set-ups		FALSE	0	Uint8
1-55	U/f Characteristic - U	App.Dependent	All set-ups		TRUE	-1	Uint16
1-56	U/f Characteristic - F	App.Dependent	All set-ups		TRUE	-1	Uint16
1-58	Flystart Test Pulses Current	30 %	All set-ups		FALSE	0	Uint16
1-59	Flystart Test Pulses Frequency	200 %	All set-ups		FALSE	0	Uint16

Par. No. #	Parameter description	Default value	4-set-up	FC 302 only	Change during operation	Conversion index	Type
<b>1-6* Load Depen. Setting</b>							
1-60	Low Speed Load Compensation	100 %	All set-ups		TRUE	0	Int16
1-61	High Speed Load Compensation	100 %	All set-ups		TRUE	0	Int16
1-62	Slip Compensation	App.Dependent	All set-ups		TRUE	0	Int16
1-63	Slip Compensation Time Constant	App.Dependent	All set-ups		TRUE	-2	UInt16
1-64	Resonance Dampening	100 %	All set-ups		TRUE	0	UInt16
1-65	Resonance Dampening Time Constant	5 ms	All set-ups		TRUE	-3	UInt8
1-66	Min. Current at Low Speed	100 %	All set-ups	x	TRUE	0	UInt8
1-67	Load Type	[0] Passive load	All set-ups	x	TRUE	-	UInt8
1-68	Minimum Inertia	App.Dependent	All set-ups	x	FALSE	-4	UInt32
1-69	Maximum Inertia	App.Dependent	All set-ups	x	FALSE	-4	UInt32
<b>1-7* Start Adjustments</b>							
1-71	Start Delay	0.0 s	All set-ups		TRUE	-1	UInt8
1-72	Start Function	[2] Coast/delay time	All set-ups		TRUE	-	UInt8
1-73	Flying Start	null	All set-ups		FALSE	-	UInt8
1-74	Start Speed [RPM]	App.Dependent	All set-ups		TRUE	67	UInt16
1-75	Start Speed [Hz]	App.Dependent	All set-ups		TRUE	-1	UInt16
1-76	Start Current	0.00 A	All set-ups		TRUE	-2	UInt32
<b>1-8* Stop Adjustments</b>							
1-80	Function at Stop	[0] Coast	All set-ups		TRUE	-	UInt8
1-81	Min Speed for Function at Stop [RPM]	App.Dependent	All set-ups		TRUE	67	UInt16
1-82	Min Speed for Function at Stop [Hz]	App.Dependent	All set-ups		TRUE	-1	UInt16
1-83	Precise Stop Function	[0] Precise ramp stop	All set-ups		FALSE	-	UInt8
1-84	Precise Stop Counter Value	100000 N/A	All set-ups		TRUE	0	UInt32
1-85	Precise Stop Speed Compensation Delay	10 ms	All set-ups		TRUE	-3	UInt8
<b>1-9* Motor Temperature</b>							
1-90	Motor Thermal Protection	[0] No protection	All set-ups		TRUE	-	UInt8
1-91	Motor External Fan	[0] No	All set-ups		TRUE	-	UInt16
1-93	Thermistor Resource	[0] None	All set-ups		TRUE	-	UInt8
1-94	ATEX ETR cur.lim. speed reduction	0.0%	2 set-ups	x	TRUE	-1	UInt16
1-95	KTY Sensor Type	[0] KTY Sensor 1	All set-ups	x	TRUE	-	UInt8
1-96	KTY Thermistor Resource	[0] None	All set-ups	x	TRUE	-	UInt8
1-97	KTY Threshold level	80 °C	1 set-up	x	TRUE	100	Int16
1-98	ATEX ETR interpol. points freq.	App.Dependent	1 set-up	x	TRUE	-1	Int16
1-99	ATEX ETR interpol points current	App.Dependent	2 set-ups	x	TRUE	0	Int16

## 4.3.3 2-\*\* Brakes

4

Par. No. #	Parameter description	Default value	4-set-up	FC 302 only	Change during operation	Conversion index	Type
<b>2-0* DC-Brake</b>							
2-00	DC Hold Current	50 %	All set-ups		TRUE	0	Uint8
2-01	DC Brake Current	50 %	All set-ups		TRUE	0	Uint16
2-02	DC Braking Time	10.0 s	All set-ups		TRUE	-1	Uint16
2-03	DC Brake Cut In Speed [RPM]	App.Dependent	All set-ups		TRUE	67	Uint16
2-04	DC Brake Cut In Speed [Hz]	App.Dependent	All set-ups		TRUE	-1	Uint16
2-05	Maximum Reference	MaxReference (P303)	All set-ups		TRUE	-3	Int32
<b>2-1* Brake Energy Funct.</b>							
2-10	Brake Function	null	All set-ups		TRUE	-	Uint8
2-11	Brake Resistor (ohm)	App.Dependent	All set-ups		TRUE	0	Uint16
2-12	Brake Power Limit (kW)	App.Dependent	All set-ups		TRUE	0	Uint32
2-13	Brake Power Monitoring	[0] Off	All set-ups		TRUE	-	Uint8
2-15	Brake Check	[0] Off	All set-ups		TRUE	-	Uint8
2-16	AC brake Max. Current	100.0 %	All set-ups		TRUE	-1	Uint32
2-17	Over-voltage Control	[0] Disabled	All set-ups		TRUE	-	Uint8
2-18	Brake Check Condition	[0] At Power Up	All set-ups		TRUE	-	Uint8
2-19	Over-voltage Gain	100 %	All set-ups		TRUE	0	Uint16
<b>2-2* Mechanical Brake</b>							
2-20	Release Brake Current	I <sub>max</sub> VLT (P1637)	All set-ups		TRUE	-2	Uint32
2-21	Activate Brake Speed [RPM]	App.Dependent	All set-ups		TRUE	67	Uint16
2-22	Activate Brake Speed [Hz]	App.Dependent	All set-ups		TRUE	-1	Uint16
2-23	Activate Brake Delay	0.0 s	All set-ups		TRUE	-1	Uint8
2-24	Stop Delay	0.0 s	All set-ups		TRUE	-1	Uint8
2-25	Brake Release Time	0.20 s	All set-ups		TRUE	-2	Uint16
2-26	Torque Ref	0.00 %	All set-ups		TRUE	-2	Int16
2-27	Torque Ramp Time	0.2 s	All set-ups		TRUE	-1	Uint8
2-28	Gain Boost Factor	1.00 N/A	All set-ups		TRUE	-2	Uint16



## 4.3.4 3-\*\* Reference/Ramps

Par. No. #	Parameter description	Default value	4-set-up	FC 302 only	Change during operation	Conversion index	Type
<b>3-0* Reference Limits</b>							
3-00	Reference Range	null	All set-ups		TRUE	-	Uint8
3-01	Reference/Feedback Unit	null	All set-ups		TRUE	-	Uint8
3-02	Minimum Reference	App.Dependent	All set-ups		TRUE	-3	Int32
3-03	Maximum Reference	App.Dependent	All set-ups		TRUE	-3	Int32
3-04	Reference Function	[0] Sum	All set-ups		TRUE	-	Uint8
<b>3-1* References</b>							
3-10	Preset Reference	0.00 %	All set-ups		TRUE	-2	Int16
3-11	Jog Speed [Hz]	App.Dependent	All set-ups		TRUE	-1	Uint16
3-12	Catch up/slow Down Value	0.00 %	All set-ups		TRUE	-2	Int16
3-13	Reference Site	[0] Linked to Hand / Auto	All set-ups		TRUE	-	Uint8
3-14	Preset Relative Reference	0.00 %	All set-ups		TRUE	-2	Int32
3-15	Reference Resource 1	null	All set-ups		TRUE	-	Uint8
3-16	Reference Resource 2	null	All set-ups		TRUE	-	Uint8
3-17	Reference Resource 3	null	All set-ups		TRUE	-	Uint8
3-18	Relative Scaling Reference Resource	[0] No function	All set-ups		TRUE	-	Uint8
3-19	Jog Speed [RPM]	App.Dependent	All set-ups		TRUE	67	Uint16
<b>3-4* Ramp 1</b>							
3-40	Ramp 1 Type	[0] Linear	All set-ups		TRUE	-	Uint8
3-41	Ramp 1 Ramp up Time	App.Dependent	All set-ups		TRUE	-2	Uint32
3-42	Ramp 1 Ramp Down Time	App.Dependent	All set-ups		TRUE	-2	Uint32
3-45	Ramp 1 S-ramp Ratio at Accel. Start	50 %	All set-ups		TRUE	0	Uint8
3-46	Ramp 1 S-ramp Ratio at Accel. End	50 %	All set-ups		TRUE	0	Uint8
3-47	Ramp 1 S-ramp Ratio at Decel. Start	50 %	All set-ups		TRUE	0	Uint8
3-48	Ramp 1 S-ramp Ratio at Decel. End	50 %	All set-ups		TRUE	0	Uint8
<b>3-5* Ramp 2</b>							
3-50	Ramp 2 Type	[0] Linear	All set-ups		TRUE	-	Uint8
3-51	Ramp 2 Ramp up Time	App.Dependent	All set-ups		TRUE	-2	Uint32
3-52	Ramp 2 Ramp down Time	App.Dependent	All set-ups		TRUE	-2	Uint32
3-55	Ramp 2 S-ramp Ratio at Accel. Start	50 %	All set-ups		TRUE	0	Uint8
3-56	Ramp 2 S-ramp Ratio at Accel. End	50 %	All set-ups		TRUE	0	Uint8
3-57	Ramp 2 S-ramp Ratio at Decel. Start	50 %	All set-ups		TRUE	0	Uint8
3-58	Ramp 2 S-ramp Ratio at Decel. End	50 %	All set-ups		TRUE	0	Uint8
<b>3-6* Ramp 3</b>							
3-60	Ramp 3 Type	[0] Linear	All set-ups		TRUE	-	Uint8
3-61	Ramp 3 Ramp up Time	App.Dependent	All set-ups		TRUE	-2	Uint32
3-62	Ramp 3 Ramp down Time	App.Dependent	All set-ups		TRUE	-2	Uint32
3-65	Ramp 3 S-ramp Ratio at Accel. Start	50 %	All set-ups		TRUE	0	Uint8
3-66	Ramp 3 S-ramp Ratio at Accel. End	50 %	All set-ups		TRUE	0	Uint8
3-67	Ramp 3 S-ramp Ratio at Decel. Start	50 %	All set-ups		TRUE	0	Uint8
3-68	Ramp 3 S-ramp Ratio at Decel. End	50 %	All set-ups		TRUE	0	Uint8
<b>3-7* Ramp 4</b>							
3-70	Ramp 4 Type	[0] Linear	All set-ups		TRUE	-	Uint8
3-71	Ramp 4 Ramp up Time	App.Dependent	All set-ups		TRUE	-2	Uint32
3-72	Ramp 4 Ramp Down Time	App.Dependent	All set-ups		TRUE	-2	Uint32
3-75	Ramp 4 S-ramp Ratio at Accel. Start	50 %	All set-ups		TRUE	0	Uint8
3-76	Ramp 4 S-ramp Ratio at Accel. End	50 %	All set-ups		TRUE	0	Uint8
3-77	Ramp 4 S-ramp Ratio at Decel. Start	50 %	All set-ups		TRUE	0	Uint8
3-78	Ramp 4 S-ramp Ratio at Decel. End	50 %	All set-ups		TRUE	0	Uint8

Par. No. #	Parameter description	Default value	4-set-up	FC 302 only	Change during operation	Conversion index	Type
<b>3-8* Other Ramps</b>							
3-80	Jog Ramp Time	App.Dependent	All set-ups		TRUE	-2	Uint32
3-81	Quick Stop Ramp Time	App.Dependent	2 set-ups		TRUE	-2	Uint32
3-82	Quick Stop Ramp Type	[0] Linear	All set-ups		TRUE	-	Uint8
3-83	Quick Stop S-ramp Ratio at Decel. Start	50 %	All set-ups		TRUE	0	Uint8
3-84	Quick Stop S-ramp Ratio at Decel. End	50 %	All set-ups		TRUE	0	Uint8
<b>3-9* Digital Pot.Meter</b>							
3-90	Step Size	0.10 %	All set-ups		TRUE	-2	Uint16
3-91	Ramp Time	1.00 s	All set-ups		TRUE	-2	Uint32
3-92	Power Restore	[0] Off	All set-ups		TRUE	-	Uint8
3-93	Maximum Limit	100 %	All set-ups		TRUE	0	Int16
3-94	Minimum Limit	-100 %	All set-ups		TRUE	0	Int16
3-95	Ramp Delay	App.Dependent	All set-ups		TRUE	-3	TimD

## 4.3.5 4-\*\* Limits / Warnings

Par. No. #	Parameter description	Default value	4-set-up	FC 302 only	Change during operation	Conversion index	Type
<b>4-1* Motor Limits</b>							
4-10	Motor Speed Direction	null	All set-ups		FALSE	-	Uint8
4-11	Motor Speed Low Limit [RPM]	App.Dependent	All set-ups		TRUE	67	Uint16
4-12	Motor Speed Low Limit [Hz]	App.Dependent	All set-ups		TRUE	-1	Uint16
4-13	Motor Speed High Limit [RPM]	App.Dependent	All set-ups		TRUE	67	Uint16
4-14	Motor Speed High Limit [Hz]	App.Dependent	All set-ups		TRUE	-1	Uint16
4-16	Torque Limit Motor Mode	App.Dependent	All set-ups		TRUE	-1	Uint16
4-17	Torque Limit Generator Mode	100.0 %	All set-ups		TRUE	-1	Uint16
4-18	Current Limit	App.Dependent	All set-ups		TRUE	-1	Uint32
4-19	Max Output Frequency	132.0 Hz	All set-ups		FALSE	-1	Uint16
<b>4-2* Limit Factors</b>							
4-20	Torque Limit Factor Source	[0] No function	All set-ups		TRUE	-	Uint8
4-21	Speed Limit Factor Source	[0] No function	All set-ups		TRUE	-	Uint8
<b>4-3* Motor Speed Mon.</b>							
4-30	Motor Feedback Loss Function	[2] Trip	All set-ups		TRUE	-	Uint8
4-31	Motor Feedback Speed Error	300 RPM	All set-ups		TRUE	67	Uint16
4-32	Motor Feedback Loss Timeout	0.05 s	All set-ups		TRUE	-2	Uint16
4-34	Tracking Error Function	null	All set-ups		TRUE	-	Uint8
4-35	Tracking Error	10 RPM	All set-ups		TRUE	67	Uint16
4-36	Tracking Error Timeout	1.00 s	All set-ups		TRUE	-2	Uint16
4-37	Tracking Error Ramping	100 RPM	All set-ups		TRUE	67	Uint16
4-38	Tracking Error Ramping Timeout	1.00 s	All set-ups		TRUE	-2	Uint16
4-39	Tracking Error After Ramping Timeout	5.00 s	All set-ups		TRUE	-2	Uint16
<b>4-5* Adj. Warnings</b>							
4-50	Warning Current Low	0.00 A	All set-ups		TRUE	-2	Uint32
4-51	Warning Current High	I <sub>max</sub> VLT (P1637)	All set-ups		TRUE	-2	Uint32
4-52	Warning Speed Low	0 RPM	All set-ups		TRUE	67	Uint16
4-53	Warning Speed High	outputSpeedHighLimit (P413)	All set-ups		TRUE	67	Uint16
4-54	Warning Reference Low	-999999.999 N/A	All set-ups		TRUE	-3	Int32
4-55	Warning Reference High	999999.999 N/A	All set-ups		TRUE	-3	Int32
4-56	Warning Feedback Low	-999999.999 Reference-FeedbackUnit	All set-ups		TRUE	-3	Int32
4-57	Warning Feedback High	999999.999 Reference-FeedbackUnit	All set-ups		TRUE	-3	Int32
4-58	Missing Motor Phase Function	null	All set-ups		TRUE	-	Uint8
<b>4-6* Speed Bypass</b>							
4-60	Bypass Speed From [RPM]	App.Dependent	All set-ups		TRUE	67	Uint16
4-61	Bypass Speed From [Hz]	App.Dependent	All set-ups		TRUE	-1	Uint16
4-62	Bypass Speed To [RPM]	App.Dependent	All set-ups		TRUE	67	Uint16
4-63	Bypass Speed To [Hz]	App.Dependent	All set-ups		TRUE	-1	Uint16

## 4.3.6 5-\*\* Digital In/Out

4

Par. No. #	Parameter description	Default value	4-set-up	FC 302 only	Change during operation	Conversion index	Type
<b>5-0* Digital I/O mode</b>							
5-00	Digital I/O Mode	[0] PNP	All set-ups		FALSE	-	Uint8
5-01	Terminal 27 Mode	[0] Input	All set-ups		TRUE	-	Uint8
5-02	Terminal 29 Mode	[0] Input	All set-ups	x	TRUE	-	Uint8
<b>5-1* Digital Inputs</b>							
5-10	Terminal 18 Digital Input	null	All set-ups		TRUE	-	Uint8
5-11	Terminal 19 Digital Input	null	All set-ups		TRUE	-	Uint8
5-12	Terminal 27 Digital Input	null	All set-ups		TRUE	-	Uint8
5-13	Terminal 29 Digital Input	null	All set-ups	x	TRUE	-	Uint8
5-14	Terminal 32 Digital Input	null	All set-ups		TRUE	-	Uint8
5-15	Terminal 33 Digital Input	null	All set-ups		TRUE	-	Uint8
5-16	Terminal X30/2 Digital Input	null	All set-ups		TRUE	-	Uint8
5-17	Terminal X30/3 Digital Input	null	All set-ups		TRUE	-	Uint8
5-18	Terminal X30/4 Digital Input	null	All set-ups		TRUE	-	Uint8
5-19	Terminal 37 Safe Stop	[1] Safe Stop Alarm	1 set-up		TRUE	-	Uint8
5-20	Terminal X46/1 Digital Input	[0] No operation	All set-ups		TRUE	-	Uint8
5-21	Terminal X46/3 Digital Input	[0] No operation	All set-ups		TRUE	-	Uint8
5-22	Terminal X46/5 Digital Input	[0] No operation	All set-ups		TRUE	-	Uint8
5-23	Terminal X46/7 Digital Input	[0] No operation	All set-ups		TRUE	-	Uint8
5-24	Terminal X46/9 Digital Input	[0] No operation	All set-ups		TRUE	-	Uint8
5-25	Terminal X46/11 Digital Input	[0] No operation	All set-ups		TRUE	-	Uint8
5-26	Terminal X46/13 Digital Input	[0] No operation	All set-ups		TRUE	-	Uint8
<b>5-3* Digital Outputs</b>							
5-30	Terminal 27 Digital Output	null	All set-ups		TRUE	-	Uint8
5-31	Terminal 29 Digital Output	null	All set-ups	x	TRUE	-	Uint8
5-32	Term X30/6 Digi Out (MCB 101)	null	All set-ups		TRUE	-	Uint8
5-33	Term X30/7 Digi Out (MCB 101)	null	All set-ups		TRUE	-	Uint8
<b>5-4* Relays</b>							
5-40	Function Relay	null	All set-ups		TRUE	-	Uint8
5-41	On Delay, Relay	0.01 s	All set-ups		TRUE	-2	Uint16
5-42	Off Delay, Relay	0.01 s	All set-ups		TRUE	-2	Uint16
<b>5-5* Pulse Input</b>							
5-50	Term. 29 Low Frequency	100 Hz	All set-ups	x	TRUE	0	Uint32
5-51	Term. 29 High Frequency	100 Hz	All set-ups	x	TRUE	0	Uint32
5-52	Term. 29 Low Ref./Feedb. Value	0.000 ReferenceFeed-backUnit	All set-ups	x	TRUE	-3	Int32
5-53	Term. 29 High Ref./Feedb. Value	App.Dependent	All set-ups	x	TRUE	-3	Int32
5-54	Pulse Filter Time Constant #29	100 ms	All set-ups	x	FALSE	-3	Uint16
5-55	Term. 33 Low Frequency	100 Hz	All set-ups		TRUE	0	Uint32
5-56	Term. 33 High Frequency	100 Hz	All set-ups		TRUE	0	Uint32
5-57	Term. 33 Low Ref./Feedb. Value	0.000 ReferenceFeed-backUnit	All set-ups		TRUE	-3	Int32
5-58	Term. 33 High Ref./Feedb. Value	App.Dependent	All set-ups		TRUE	-3	Int32
5-59	Pulse Filter Time Constant #33	100 ms	All set-ups		FALSE	-3	Uint16

Par. No. #	Parameter description	Default value	4-set-up	FC 302 only	Change during operation	Conversion index	Type
<b>5-6* Pulse Output</b>							
5-60	Terminal 27 Pulse Output Variable	null	All set-ups		TRUE	-	Uint8
5-62	Pulse Output Max Freq #27	App.Dependent	All set-ups		TRUE	0	Uint32
5-63	Terminal 29 Pulse Output Variable	null	All set-ups	x	TRUE	-	Uint8
5-65	Pulse Output Max Freq #29	App.Dependent	All set-ups	x	TRUE	0	Uint32
5-66	Terminal X30/6 Pulse Output Variable	null	All set-ups		TRUE	-	Uint8
5-68	Pulse Output Max Freq #X30/6	App.Dependent	All set-ups		TRUE	0	Uint32
<b>5-7* 24V Encoder Input</b>							
5-70	Term 32/33 Pulses per Revolution	1024 N/A	All set-ups		FALSE	0	Uint16
5-71	Term 32/33 Encoder Direction	[0] Clockwise	All set-ups		FALSE	-	Uint8
<b>5-8* I/O Options</b>							
5-80	AHF Cap Reconnect Delay	25s	2 set-ups		TRUE	0	Uint16
<b>5-9* Bus Controlled</b>							
5-90	Digital & Relay Bus Control	0 N/A	All set-ups		TRUE	0	Uint32
5-93	Pulse Out #27 Bus Control	0.00 %	All set-ups		TRUE	-2	N2
5-94	Pulse Out #27 Timeout Preset	0.00 %	1 set-up		TRUE	-2	Uint16
5-95	Pulse Out #29 Bus Control	0.00 %	All set-ups	x	TRUE	-2	N2
5-96	Pulse Out #29 Timeout Preset	0.00 %	1 set-up	x	TRUE	-2	Uint16
5-97	Pulse Out #X30/6 Bus Control	0.00 %	All set-ups		TRUE	-2	N2
5-98	Pulse Out #X30/6 Timeout Preset	0.00 %	1 set-up		TRUE	-2	Uint16

## 4.3.7 6-\*\* Analog In/Out

4

Par. No. #	Parameter description	Default value	4-set-up	FC 302 only	Change during operation	Conversion index	Type
<b>6-0* Analog I/O Mode</b>							
6-00	Live Zero Timeout Time	10 s	All set-ups		TRUE	0	Uint8
6-01	Live Zero Timeout Function	[0] Off	All set-ups		TRUE	-	Uint8
<b>6-1* Analog Input 1</b>							
6-10	Terminal 53 Low Voltage	0.07 V	All set-ups		TRUE	-2	Int16
6-11	Terminal 53 High Voltage	10.00 V	All set-ups		TRUE	-2	Int16
6-12	Terminal 53 Low Current	0.14 mA	All set-ups		TRUE	-5	Int16
6-13	Terminal 53 High Current	20.00 mA	All set-ups		TRUE	-5	Int16
6-14	Terminal 53 Low Ref./Feedb. Value	0 ReferenceFeedbackUnit	All set-ups		TRUE	-3	Int32
6-15	Terminal 53 High Ref./Feedb. Value	App.Dependent	All set-ups		TRUE	-3	Int32
6-16	Terminal 53 Filter Time Constant	0.001 s	All set-ups		TRUE	-3	Uint16
<b>6-2* Analog Input 2</b>							
6-20	Terminal 54 Low Voltage	0.07 V	All set-ups		TRUE	-2	Int16
6-21	Terminal 54 High Voltage	10.00 V	All set-ups		TRUE	-2	Int16
6-22	Terminal 54 Low Current	0.14 mA	All set-ups		TRUE	-5	Int16
6-23	Terminal 54 High Current	20.00 mA	All set-ups		TRUE	-5	Int16
6-24	Terminal 54 Low Ref./Feedb. Value	0 ReferenceFeedbackUnit	All set-ups		TRUE	-3	Int32
6-25	Terminal 54 High Ref./Feedb. Value	App.Dependent	All set-ups		TRUE	-3	Int32
6-26	Terminal 54 Filter Time Constant	0.001 s	All set-ups		TRUE	-3	Uint16
<b>6-3* Analog Input 3</b>							
6-30	Terminal X30/11 Low Voltage	0.07 V	All set-ups		TRUE	-2	Int16
6-31	Terminal X30/11 High Voltage	10.00 V	All set-ups		TRUE	-2	Int16
6-34	Term. X30/11 Low Ref./Feedb. Value	0 ReferenceFeedbackUnit	All set-ups		TRUE	-3	Int32
6-35	Term. X30/11 High Ref./Feedb. Value	App.Dependent	All set-ups		TRUE	-3	Int32
6-36	Term. X30/11 Filter Time Constant	0.001 s	All set-ups		TRUE	-3	Uint16
<b>6-4* Analog Input 4</b>							
6-40	Terminal X30/12 Low Voltage	0.07 V	All set-ups		TRUE	-2	Int16
6-41	Terminal X30/12 High Voltage	10.00 V	All set-ups		TRUE	-2	Int16
6-44	Term. X30/12 Low Ref./Feedb. Value	0 ReferenceFeedbackUnit	All set-ups		TRUE	-3	Int32
6-45	Term. X30/12 High Ref./Feedb. Value	App.Dependent	All set-ups		TRUE	-3	Int32
6-46	Term. X30/12 Filter Time Constant	0.001 s	All set-ups		TRUE	-3	Uint16
<b>6-5* Analog Output 1</b>							
6-50	Terminal 42 Output	null	All set-ups		TRUE	-	Uint8
6-51	Terminal 42 Output Min Scale	0.00 %	All set-ups		TRUE	-2	Int16
6-52	Terminal 42 Output Max Scale	100.00 %	All set-ups		TRUE	-2	Int16
6-53	Term 42 Output Bus Ctrl	0.00 %	All set-ups		TRUE	-2	N2
6-54	Terminal 42 Output Timeout Preset	0.00 %	1 set-up		TRUE	-2	Uint16
6-55	Analog Output Filter	[0] Off	1 set-up		TRUE	-	Uint8
<b>6-6* Analog Output 2</b>							
6-60	Terminal X30/8 Output	null	All set-ups		TRUE	-	Uint8
6-61	Terminal X30/8 Min. Scale	0.00 %	All set-ups		TRUE	-2	Int16
6-62	Terminal X30/8 Max. Scale	100.00 %	All set-ups		TRUE	-2	Int16
6-63	Terminal X30/8 Bus Control	0.00 %	All set-ups		TRUE	-2	N2
6-64	Terminal X30/8 Output Timeout Preset	0.00 %	1 set-up		TRUE	-2	Uint16

Par. No. #	Parameter description	Default value	4-set-up	FC 302 only	Change during operation	Conversion index	Type
<b>6-7* Analog Output 3</b>							
6-70	Terminal X45/1 Output	null	All set-ups		TRUE	-	Uint8
6-71	Terminal X45/1 Min. Scale	0.00 %	All set-ups		TRUE	-2	Int16
6-72	Terminal X45/1 Max. Scale	100.00 %	All set-ups		TRUE	-2	Int16
6-73	Terminal X45/1 Bus Control	0.00 %	All set-ups		TRUE	-2	N2
6-74	Terminal X45/1 Output Timeout Preset	0.00 %	1 set-up		TRUE	-2	Uint16
<b>6-8* Analog Output 4</b>							
6-80	Terminal X45/3 Output	null	All set-ups		TRUE	-	Uint8
6-81	Terminal X45/3 Min. Scale	0.00 %	All set-ups		TRUE	-2	Int16
6-82	Terminal X45/3 Max. Scale	100.00 %	All set-ups		TRUE	-2	Int16
6-83	Terminal X45/3 Bus Control	0.00 %	All set-ups		TRUE	-2	N2
6-84	Terminal X45/3 Output Timeout Preset	0.00 %	1 set-up		TRUE	-2	Uint16

## 4.3.8 7-\*\* Controllers

4

Par. No. #	Parameter description	Default value	4-set-up	FC 302 only	Change during operation	Conversion index	Type
<b>7-0* Speed PID Ctrl.</b>							
7-00	Speed PID Feedback Source	null	All set-ups		FALSE	-	Uint8
7-02	Speed PID Proportional Gain	App.Dependent	All set-ups		TRUE	-3	Uint16
7-03	Speed PID Integral Time	App.Dependent	All set-ups		TRUE	-4	Uint32
7-04	Speed PID Differentiation Time	App.Dependent	All set-ups		TRUE	-4	Uint16
7-05	Speed PID Diff. Gain Limit	5.0 N/A	All set-ups		TRUE	-1	Uint16
7-06	Speed PID Lowpass Filter Time	App.Dependent	All set-ups		TRUE	-4	Uint16
7-07	Speed PID Feedback Gear Ratio	1.0000 N/A	All set-ups		FALSE	-4	Uint32
7-08	Speed PID Feed Forward Factor	0 %	All set-ups		FALSE	0	Uint16
7-09	Speed PID Error Correction w/ Ramp	300RPM	All set-ups		TRUE	67	Uint32
<b>7-1* Torque PI Ctrl.</b>							
7-12	Torque PI Proportional Gain	100 %	All set-ups		TRUE	0	Uint16
7-13	Torque PI Integration Time	0.020 s	All set-ups		TRUE	-3	Uint16
<b>7-2* Process Ctrl. Feedb</b>							
7-20	Process CL Feedback 1 Resource	[0] No function	All set-ups		TRUE	-	Uint8
7-22	Process CL Feedback 2 Resource	[0] No function	All set-ups		TRUE	-	Uint8
<b>7-3* Process PID Ctrl.</b>							
7-30	Process PID Normal/ Inverse Control	[0] Normal	All set-ups		TRUE	-	Uint8
7-31	Process PID Anti Windup	[1] On	All set-ups		TRUE	-	Uint8
7-32	Process PID Start Speed	0 RPM	All set-ups		TRUE	67	Uint16
7-33	Process PID Proportional Gain	0.01 N/A	All set-ups		TRUE	-2	Uint16
7-34	Process PID Integral Time	10000.00 s	All set-ups		TRUE	-2	Uint32
7-35	Process PID Differentiation Time	0.00 s	All set-ups		TRUE	-2	Uint16
7-36	Process PID Diff. Gain Limit	5.0 N/A	All set-ups		TRUE	-1	Uint16
7-38	Process PID Feed Forward Factor	0 %	All set-ups		TRUE	0	Uint16
7-39	On Reference Bandwidth	5 %	All set-ups		TRUE	0	Uint8
<b>7-4* Adv. Process PID I</b>							
7-40	Process PID I-part Reset	[0] No	All set-ups		TRUE	-	Uint8
7-41	Process PID Output Neg. Clamp	-100 %	All set-ups		TRUE	0	Int16
7-42	Process PID Output Pos. Clamp	100 %	All set-ups		TRUE	0	Int16
7-43	Process PID Gain Scale at Min. Ref.	100 %	All set-ups		TRUE	0	Int16
7-44	Process PID Gain Scale at Max. Ref.	100 %	All set-ups		TRUE	0	Int16
7-45	Process PID Feed Fwd Resource	[0] No function	All set-ups		TRUE	-	Uint8
7-46	Process PID Feed Fwd Normal/ Inv. Ctrl.	[0] Normal	All set-ups		TRUE	-	Uint8
7-48	PCD Feed Forward	0 N/A	All set-ups	x	TRUE	0	Uint16
7-49	Process PID Output Normal/ Inv. Ctrl.	[0] Normal	All set-ups		TRUE	-	Uint8
<b>7-5* Adv. Process PID II</b>							
7-50	Process PID Extended PID	[1] Enabled	All set-ups		TRUE	-	Uint8
7-51	Process PID Feed Fwd Gain	1.00 N/A	All set-ups		TRUE	-2	Uint16
7-52	Process PID Feed Fwd Ramp up	0.01 s	All set-ups		TRUE	-2	Uint32
7-53	Process PID Feed Fwd Ramp down	0.01 s	All set-ups		TRUE	-2	Uint32
7-56	Process PID Ref. Filter Time	0.001 s	All set-ups		TRUE	-3	Uint16
7-57	Process PID Fb. Filter Time	0.001 s	All set-ups		TRUE	-3	Uint16



## 4.3.9 8-\*\* Comm. and Options

Par. No. #	Parameter description	Default value	4-set-up	FC 302 only	Change during operation	Conversion index	Type
<b>8-0* General Settings</b>							
8-01	Control Site	[0] Digital and ctrl.word	All set-ups		TRUE	-	Uint8
8-02	Control Word Source	null	All set-ups		TRUE	-	Uint8
8-03	Control Word Timeout Time	1.0 s	1 set-up		TRUE	-1	Uint32
8-04	Control Word Timeout Function	null	1 set-up		TRUE	-	Uint8
8-05	End-of-Timeout Function	[1] Resume set-up	1 set-up		TRUE	-	Uint8
8-06	Reset Control Word Timeout	[0] Do not reset	All set-ups		TRUE	-	Uint8
8-07	Diagnosis Trigger	[0] Disable	2 set-ups		TRUE	-	Uint8
8-08	Readout Filtering	null	All set-ups		TRUE	-	Uint8
<b>8-1* Ctrl. Word Settings</b>							
8-10	Control Word Profile	[0] FC profile	All set-ups		TRUE	-	Uint8
8-13	Configurable Status Word STW	null	All set-ups		TRUE	-	Uint8
8-14	Configurable Control Word CTW	[1] Profile default	All set-ups		TRUE	-	Uint8
<b>8-3* FC Port Settings</b>							
8-30	Protocol	[0] FC	1 set-up		TRUE	-	Uint8
8-31	Address	1 N/A	1 set-up		TRUE	0	Uint8
8-32	FC Port Baud Rate	null	1 set-up		TRUE	-	Uint8
8-33	Parity / Stop Bits	[0] Even Parity, 1 Stop Bit	1 set-up		TRUE	-	Uint8
8-34	Estimated cycle time	0 ms	2 set-ups		TRUE	-3	Uint32
8-35	Minimum Response Delay	10 ms	All set-ups		TRUE	-3	Uint16
8-36	Max Response Delay	App.Dependent	1 set-up		TRUE	-3	Uint16
8-37	Max Inter-Char Delay	App.Dependent	1 set-up		TRUE	-5	Uint16
<b>8-4* FC MC protocol set</b>							
8-40	Telegram selection	[1] Standard telegram 1	2 set-ups		TRUE	-	Uint8
8-41	Parameters for signals	0	All set-ups		FALSE	-	Uint16
8-42	PCD write configuration	App.Dependent	All set-ups		TRUE	-	Uint16
8-43	PCD read configuration	App.Dependent	All set-ups		TRUE	-	Uint16
<b>8-5* Digital/Bus</b>							
8-50	Coasting Select	[3] Logic OR	All set-ups		TRUE	-	Uint8
8-51	Quick Stop Select	[3] Logic OR	All set-ups		TRUE	-	Uint8
8-52	DC Brake Select	[3] Logic OR	All set-ups		TRUE	-	Uint8
8-53	Start Select	[3] Logic OR	All set-ups		TRUE	-	Uint8
8-54	Reversing Select	[3] Logic OR	All set-ups		TRUE	-	Uint8
8-55	Set-up Select	[3] Logic OR	All set-ups		TRUE	-	Uint8
8-56	Preset Reference Select	[3] Logic OR	All set-ups		TRUE	-	Uint8
8-57	Profidrive OFF2 Select	[3] Logic OR	All set-ups		TRUE	-	Uint8
8-58	Profidrive OFF3 Select	[3] Logic OR	All set-ups		TRUE	-	Uint8
<b>8-8* FC Port Diagnostics</b>							
8-80	Bus Message Count	0 N/A	All set-ups		TRUE	0	Uint32
8-81	Bus Error Count	0 N/A	All set-ups		TRUE	0	Uint32
8-82	Slave Messages Rcvd	0 N/A	All set-ups		TRUE	0	Uint32
8-83	Slave Error Count	0 N/A	All set-ups		TRUE	0	Uint32
<b>8-9* Bus Jog</b>							
8-90	Bus Jog 1 Speed	100 RPM	All set-ups		TRUE	67	Uint16
8-91	Bus Jog 2 Speed	App.Dependent	All set-ups		TRUE	67	Uint16

## 4.3.10 9-\*\* Profibus

4

Par. No. #	Parameter description	Default value	4-set-up	FC 302 only	Change during operation	Conversion index	Type
9-00	Setpoint	0 N/A	All set-ups		TRUE	0	Uint16
9-07	Actual Value	0 N/A	All set-ups		FALSE	0	Uint16
9-15	PCD Write Configuration	App.Dependent	1 set-up		TRUE	-	Uint16
9-16	PCD Read Configuration	App.Dependent	2 set-ups		TRUE	-	Uint16
9-18	Node Address	126 N/A	1 set-up		TRUE	0	Uint8
9-22	Telegram Selection	[100] None	1 set-up		TRUE	-	Uint8
9-23	Parameters for Signals	0	All set-ups		TRUE	-	Uint16
9-27	Parameter Edit	[1] Enabled	2 set-ups		FALSE	-	Uint16
9-28	Process Control	[1] Enable cyclic master	2 set-ups		FALSE	-	Uint8
9-44	Fault Message Counter	0 N/A	All set-ups		TRUE	0	Uint16
9-45	Fault Code	0 N/A	All set-ups		TRUE	0	Uint16
9-47	Fault Number	0 N/A	All set-ups		TRUE	0	Uint16
9-52	Fault Situation Counter	0 N/A	All set-ups		TRUE	0	Uint16
9-53	Profibus Warning Word	0 N/A	All set-ups		TRUE	0	V2
9-63	Actual Baud Rate	[255] No baudrate found	All set-ups		TRUE	-	Uint8
9-64	Device Identification	0 N/A	All set-ups		TRUE	0	Uint16
9-65	Profile Number	0 N/A	All set-ups		TRUE	0	OctStr[2]
9-67	Control Word 1	0 N/A	All set-ups		TRUE	0	V2
9-68	Status Word 1	0 N/A	All set-ups		TRUE	0	V2
9-71	Profibus Save Data Values	[0] Off	All set-ups		TRUE	-	Uint8
9-72	ProfibusDriveReset	[0] No action	1 set-up		FALSE	-	Uint8
9-75	DO Identification	0 N/A	All set-ups		TRUE	0	Uint16
9-80	Defined Parameters (1)	0 N/A	All set-ups		FALSE	0	Uint16
9-81	Defined Parameters (2)	0 N/A	All set-ups		FALSE	0	Uint16
9-82	Defined Parameters (3)	0 N/A	All set-ups		FALSE	0	Uint16
9-83	Defined Parameters (4)	0 N/A	All set-ups		FALSE	0	Uint16
9-84	Defined Parameters (5)	0 N/A	All set-ups		FALSE	0	Uint16
9-90	Changed Parameters (1)	0 N/A	All set-ups		FALSE	0	Uint16
9-91	Changed Parameters (2)	0 N/A	All set-ups		FALSE	0	Uint16
9-92	Changed Parameters (3)	0 N/A	All set-ups		FALSE	0	Uint16
9-93	Changed parameters (4)	0 N/A	All set-ups		FALSE	0	Uint16
9-94	Changed parameters (5)	0 N/A	All set-ups		FALSE	0	Uint16
9-99	Profibus Revision Counter	0 N/A	All set-ups		TRUE	0	Uint16

## 4.3.11 10-\*\* CAN Fieldbus

Par. No. #	Parameter description	Default value	4-set-up	FC 302 only	Change during operation	Conversion index	Type
<b>10-0* Common Settings</b>							
10-00	CAN Protocol	null	2 set-ups		FALSE	-	Uint8
10-01	Baud Rate Select	null	2 set-ups		TRUE	-	Uint8
10-02	MAC ID	App.Dependent	2 set-ups		TRUE	0	Uint8
10-05	Readout Transmit Error Counter	0 N/A	All set-ups		TRUE	0	Uint8
10-06	Readout Receive Error Counter	0 N/A	All set-ups		TRUE	0	Uint8
10-07	Readout Bus Off Counter	0 N/A	All set-ups		TRUE	0	Uint8
<b>10-1* DeviceNet</b>							
10-10	Process Data Type Selection	null	All set-ups		TRUE	-	Uint8
10-11	Process Data Config Write	App.Dependent	All set-ups		TRUE	-	Uint16
10-12	Process Data Config Read	App.Dependent	All set-ups		TRUE	-	Uint16
10-13	Warning Parameter	0 N/A	All set-ups		TRUE	0	Uint16
10-14	Net Reference	[0] Off	2 set-ups		TRUE	-	Uint8
10-15	Net Control	[0] Off	2 set-ups		TRUE	-	Uint8
<b>10-2* COS Filters</b>							
10-20	COS Filter 1	0 N/A	All set-ups		FALSE	0	Uint16
10-21	COS Filter 2	0 N/A	All set-ups		FALSE	0	Uint16
10-22	COS Filter 3	0 N/A	All set-ups		FALSE	0	Uint16
10-23	COS Filter 4	0 N/A	All set-ups		FALSE	0	Uint16
<b>10-3* Parameter Access</b>							
10-30	Array Index	0 N/A	2 set-ups		TRUE	0	Uint8
10-31	Store Data Values	[0] Off	All set-ups		TRUE	-	Uint8
10-32	Devicenet Revision	App.Dependent	All set-ups		TRUE	0	Uint16
10-33	Store Always	[0] Off	1 set-up		TRUE	-	Uint8
10-34	DeviceNet Product Code	App.Dependent	1 set-up		TRUE	0	Uint16
10-39	Devicenet F Parameters	0 N/A	All set-ups		TRUE	0	Uint32
<b>10-5* CANopen</b>							
10-50	Process Data Config Write.	App.Dependent	2 set-ups		TRUE	-	Uint16
10-51	Process Data Config Read.	App.Dependent	2 set-ups		TRUE	-	Uint16

## 4.3.12 12-\*\* Ethernet

4

Par. No. #	Parameter description	Default value	4-set-up	FC 302 only	Change during operation	Conversion index	Type
<b>12-0* IP Settings</b>							
12-00	IP Address Assignment	null	2 set-ups		TRUE	-	UInt8
12-01	IP Address	0 N/A	1 set-up		TRUE	0	OctStr[4]
12-02	Subnet Mask	0 N/A	1 set-up		TRUE	0	OctStr[4]
12-03	Default Gateway	0 N/A	1 set-up		TRUE	0	OctStr[4]
12-04	DHCP Server	0 N/A	2 set-ups		TRUE	0	OctStr[4]
12-05	Lease Expires	App.Dependent	All set-ups		TRUE	0	TimD
12-06	Name Servers	0 N/A	1 set-up		TRUE	0	OctStr[4]
12-07	Domain Name	0 N/A	1 set-up		TRUE	0	VisStr[48]
12-08	Host Name	0 N/A	1 set-up		TRUE	0	VisStr[48]
12-09	Physical Address	0 N/A	1 set-up		TRUE	0	VisStr[17]
<b>12-1* Ethernet Link Parameters</b>							
12-10	Link Status	[0] No Link	1 set-up		TRUE	-	UInt8
12-11	Link Duration	App.Dependent	All set-ups		TRUE	0	TimD
12-12	Auto Negotiation	[1] On	2 set-ups		TRUE	-	UInt8
12-13	Link Speed	[0] None	2 set-ups		TRUE	-	UInt8
12-14	Link Duplex	[1] Full Duplex	2 set-ups		TRUE	-	UInt8
<b>12-2* Process Data</b>							
12-20	Control Instance	App.Dependent	1 set-up		TRUE	0	UInt8
12-21	Process Data Config Write	App.Dependent	All set-ups		TRUE	-	UInt16
12-22	Process Data Config Read	App.Dependent	All set-ups		TRUE	-	UInt16
12-23	Process Data Config Write Size	16 N/A	All set-ups		TRUE	0	UInt32
12-24	Process Data Config Read Size	16 N/A	All set-ups		TRUE	0	UInt32
12-27	Primary Master	0 N/A	1 set-up		FALSE	0	
12-28	Store Data Values	[0] Off	All set-ups		TRUE	-	UInt8
12-29	Store Always	[0] Off	1 set-up		TRUE	-	UInt8
<b>12-3* EtherNet/IP</b>							
12-30	Warning Parameter	0 N/A	All set-ups		TRUE	0	UInt16
12-31	Net Reference	[0] Off	2 set-ups		TRUE	-	UInt8
12-32	Net Control	[0] Off	2 set-ups		TRUE	-	UInt8
12-33	CIP Revision	App.Dependent	All set-ups		TRUE	0	UInt16
12-34	CIP Product Code	App.Dependent	1 set-up		TRUE	0	UInt16
12-35	EDS Parameter	0 N/A	All set-ups		TRUE	0	UInt32
12-37	COS Inhibit Timer	0 N/A	All set-ups		TRUE	0	UInt16
12-38	COS Filter	0 N/A	All set-ups		TRUE	0	UInt16
<b>12-4* Modbus TCP</b>							
12-40	Status Parameter	0 N/A	All set-ups		TRUE	0	UInt16
12-41	Slave Message Count	0 N/A	All set-ups		TRUE	0	UInt32
12-42	Slave Exception Message Count	0 N/A	All set-ups		TRUE	0	UInt32
<b>12-5* EtherCAT</b>							
12-50	Configured Station Alias	0 N/A	1 set-up		FALSE	0	UInt16
12-51	Configured Station Address	0 N/A	All set-ups		TRUE	0	UInt16
12-59	EtherCAT Status	0 N/A	All set-ups		TRUE	0	UInt32

Par. No. #	Parameter description	Default value	4-set-up	FC 302 only	Change during operation	Conversion index	Type
<b>12-8* Other Ethernet Services</b>							
12-80	FTP Server	[0] Disabled	2 set-ups		TRUE	-	Uint8
12-81	HTTP Server	[0] Disabled	2 set-ups		TRUE	-	Uint8
12-82	SMTP Service	[0] Disabled	2 set-ups		TRUE	-	Uint8
12-89	Transparent Socket Channel Port	App.Dependent	2 set-ups		TRUE	0	Uint16
<b>12-9* Advanced Ethernet Services</b>							
12-90	Cable Diagnostic	[0] Disabled	2 set-ups		TRUE	-	Uint8
12-91	MDI-X	[1] Enabled	2 set-ups		TRUE	-	Uint8
12-92	IGMP Snooping	[1] Enabled	2 set-ups		TRUE	-	Uint8
12-93	Cable Error Length	0 N/A	1 set-up		TRUE	0	Uint16
12-94	Broadcast Storm Protection	-1 %	2 set-ups		TRUE	0	Int8
12-95	Broadcast Storm Filter	[0] Broadcast only	2 set-ups		TRUE	-	Uint8
12-96	Port Mirroring	null	2 set-ups		TRUE	-	Uint8
12-98	Interface Counters	4000 N/A	All set-ups		TRUE	0	Uint32
12-99	Media Counters	0 N/A	All set-ups		TRUE	0	Uint32

## 4.3.13 13-\*\* Smart Logic

Par. No. #	Parameter description	Default value	4-set-up	FC 302 only	Change during operation	Conversion index	Type
<b>13-0* SLC Settings</b>							
13-00	SL Controller Mode	null	2 set-ups		TRUE	-	Uin8
13-01	Start Event	null	2 set-ups		TRUE	-	Uin8
13-02	Stop Event	null	2 set-ups		TRUE	-	Uin8
13-03	Reset SLC	[0] Do not reset SLC	All set-ups		TRUE	-	Uin8
<b>13-1* Comparators</b>							
13-10	Comparator Operand	null	2 set-ups		TRUE	-	Uin8
13-11	Comparator Operator	null	2 set-ups		TRUE	-	Uin8
13-12	Comparator Value	App.Dependent	2 set-ups		TRUE	-3	Int32
<b>13-1* RS Flip Flops</b>							
13-15	RS-FF Operand S	null	2 set-ups		TRUE	-	Uin8
13-16	RS-FF Operand R	null	2 set-ups		TRUE	-	Uin8
<b>13-2* Timers</b>							
13-20	SL Controller Timer	App.Dependent	1 set-up		TRUE	-3	TimD
<b>13-4* Logic Rules</b>							
13-40	Logic Rule Boolean 1	null	2 set-ups		TRUE	-	Uin8
13-41	Logic Rule Operator 1	null	2 set-ups		TRUE	-	Uin8
13-42	Logic Rule Boolean 2	null	2 set-ups		TRUE	-	Uin8
13-43	Logic Rule Operator 2	null	2 set-ups		TRUE	-	Uin8
13-44	Logic Rule Boolean 3	null	2 set-ups		TRUE	-	Uin8
<b>13-5* States</b>							
13-51	SL Controller Event	null	2 set-ups		TRUE	-	Uin8
13-52	SL Controller Action	null	2 set-ups		TRUE	-	Uin8

## 4.3.14 14-\*\* Special Functions

Par. No. #	Parameter description	Default value	4-set-up	FC 302 only	Change during operation	Conversion index	Type
<b>14-0* Inverter Switching</b>							
14-00	Switching Pattern	null	All set-ups		TRUE	-	Uint8
14-01	Switching Frequency	null	All set-ups		TRUE	-	Uint8
14-03	Overmodulation	[1] On	All set-ups		FALSE	-	Uint8
14-04	PWM Random	[0] Off	All set-ups		TRUE	-	Uint8
14-06	Dead Time Compensation	[1] On	All set-ups		TRUE	-	Uint8
<b>14-1* Mains On/Off</b>							
14-10	Mains Failure	[0] No function	All set-ups		FALSE	-	Uint8
14-11	Mains Voltage at Mains Fault	App.Dependent	All set-ups		TRUE	0	Uint16
14-12	Function at Mains Imbalance	[0] Trip	All set-ups		TRUE	-	Uint8
14-13	Mains Failure Step Factor	1.0 N/A	All set-ups		TRUE	-1	Uint8
14-14	Kin. Backup Time Out	60 s	All set-ups		TRUE	0	Uint8
<b>14-2* Trip Reset</b>							
14-20	Reset Mode	[0] Manual reset	All set-ups		TRUE	-	Uint8
14-21	Automatic Restart Time	App.Dependent	All set-ups		TRUE	0	Uint16
14-22	Operation Mode	[0] Normal operation	All set-ups		TRUE	-	Uint8
14-23	Typecode Setting	null	2 set-ups		FALSE	-	Uint8
14-24	Trip Delay at Current Limit	60 s	All set-ups		TRUE	0	Uint8
14-25	Trip Delay at Torque Limit	60 s	All set-ups		TRUE	0	Uint8
14-26	Trip Delay at Inverter Fault	App.Dependent	All set-ups		TRUE	0	Uint8
14-28	Production Settings	[0] No action	All set-ups		TRUE	-	Uint8
14-29	Service Code	0 N/A	All set-ups		TRUE	0	Int32
<b>14-3* Current Limit Ctrl.</b>							
14-30	Current Lim Ctrl, Proportional Gain	100 %	All set-ups		FALSE	0	Uint16
14-31	Current Lim Ctrl, Integration Time	0.020 s	All set-ups		FALSE	-3	Uint16
14-32	Current Lim Ctrl, Filter Time	1.0 ms	All set-ups		TRUE	-4	Uint16
14-35	Stall Protection	[1] Enabled	All set-ups		FALSE	-	Uint8
<b>14-4* Energy Optimising</b>							
14-40	VT Level	66 %	All set-ups		FALSE	0	Uint8
14-41	AEO Minimum Magnetisation	App.Dependent	All set-ups		TRUE	0	Uint8
14-42	Minimum AEO Frequency	10 Hz	All set-ups		TRUE	0	Uint8
14-43	Motor Cosphi	App.Dependent	All set-ups		TRUE	-2	Uint16
<b>14-5* Environment</b>							
14-50	RFI Filter	[1] On	1 set-up	x	FALSE	-	Uint8
14-51	DC Link Compensation	[1] On	1 set-up		TRUE	-	Uint8
14-52	Fan Control	[0] Auto	All set-ups		TRUE	-	Uint8
14-53	Fan Monitor	[1] Warning	All set-ups		TRUE	-	Uint8
14-55	Output Filter	[0] No Filter	All set-ups		FALSE	-	Uint8
14-56	Capacitance Output Filter	App.Dependent	All set-ups		FALSE	-7	Uint16
14-57	Inductance Output Filter	App.Dependent	All set-ups		FALSE	-6	Uint16
14-59	Actual Number of Inverter Units	App.Dependent	1 set-up	x	FALSE	0	Uint8

Par. No. #	Parameter description	Default value	4-set-up	FC 302 only	Change during operation	Conversion index	Type
<b>14-7* Compatibility</b>							
14-72	Legacy Alarm Word	0 N/A	All set-ups		FALSE	0	Uint32
14-73	Legacy Warning Word	0 N/A	All set-ups		FALSE	0	Uint32
14-74	Leg. Ext. Status Word	0 N/A	All set-ups		FALSE	0	Uint32
<b>14-8* Options</b>							
14-80	Option Supplied by External 24VDC	[1] Yes	2 set-ups		FALSE	-	Uint8
14-89	Option Detection	[0] Protect Option Config.	1 set-up		TRUE	-	Uint8
<b>14-9* Fault Settings</b>							
14-90	Fault Level	null	1 set-up		TRUE	-	Uint8



4.3.15 15-\*\* Drive Information

Par. No. #	Parameter description	Default value	4-set-up	FC 302 only	Change during operation	Conversion index	Type
<b>15-0* Operating Data</b>							
15-00	Operating Hours	0 h	All set-ups		FALSE	74	Uint32
15-01	Running Hours	0 h	All set-ups		FALSE	74	Uint32
15-02	kWh Counter	0 kWh	All set-ups		FALSE	75	Uint32
15-03	Power Up's	0 N/A	All set-ups		FALSE	0	Uint32
15-04	Over Temp's	0 N/A	All set-ups		FALSE	0	Uint16
15-05	Over Volt's	0 N/A	All set-ups		FALSE	0	Uint16
15-06	Reset kWh Counter	[0] Do not reset	All set-ups		TRUE	-	Uint8
15-07	Reset Running Hours Counter	[0] Do not reset	All set-ups		TRUE	-	Uint8
<b>15-1* Data Log Settings</b>							
15-10	Logging Source	0	2 set-ups		TRUE	-	Uint16
15-11	Logging Interval	App.Dependent	2 set-ups		TRUE	-3	TimD
15-12	Trigger Event	[0] False	1 set-up		TRUE	-	Uint8
15-13	Logging Mode	[0] Log always	2 set-ups		TRUE	-	Uint8
15-14	Samples Before Trigger	50 N/A	2 set-ups		TRUE	0	Uint8
<b>15-2* Historic Log</b>							
15-20	Historic Log: Event	0 N/A	All set-ups		FALSE	0	Uint8
15-21	Historic Log: Value	0 N/A	All set-ups		FALSE	0	Uint32
15-22	Historic Log: Time	0 ms	All set-ups		FALSE	-3	Uint32
<b>15-3* Fault Log</b>							
15-30	Fault Log: Error Code	0 N/A	All set-ups		FALSE	0	Uint8
15-31	Fault Log: Value	0 N/A	All set-ups		FALSE	0	Int16
15-32	Fault Log: Time	0 s	All set-ups		FALSE	0	Uint32
<b>15-4* Drive Identification</b>							
15-40	FC Type	0 N/A	All set-ups		FALSE	0	VisStr[6]
15-41	Power Section	0 N/A	All set-ups		FALSE	0	VisStr[20]
15-42	Voltage	0 N/A	All set-ups		FALSE	0	VisStr[20]
15-43	Software Version	0 N/A	All set-ups		FALSE	0	VisStr[5]
15-44	Ordered Typecode String	0 N/A	All set-ups		FALSE	0	VisStr[40]
15-45	Actual Typecode String	0 N/A	All set-ups		FALSE	0	VisStr[40]
	Frequency Converter Ordering						
15-46	No	0 N/A	All set-ups		FALSE	0	VisStr[8]
15-47	Power Card Ordering No	0 N/A	All set-ups		FALSE	0	VisStr[8]
15-48	LCP Id No	0 N/A	All set-ups		FALSE	0	VisStr[20]
15-49	SW ID Control Card	0 N/A	All set-ups		FALSE	0	VisStr[20]
15-50	SW ID Power Card	0 N/A	All set-ups		FALSE	0	VisStr[20]
	Frequency Converter Serial						
15-51	Number	0 N/A	All set-ups		FALSE	0	VisStr[10]
15-53	Power Card Serial Number	0 N/A	All set-ups		FALSE	0	VisStr[19]
15-59	CSIV Filename	App.Dependent	1 set-up		FALSE	0	VisStr[16]

Par. No. #	Parameter description	Default value	4-set-up	FC 302 only	Change during operation	Conversion index	Type
<b>15-6* Option Ident</b>							
15-60	Option Mounted	0 N/A	All set-ups		FALSE	0	VisStr[30]
15-61	Option SW Version	0 N/A	All set-ups		FALSE	0	VisStr[20]
15-62	Option Ordering No	0 N/A	All set-ups		FALSE	0	VisStr[8]
15-63	Option Serial No	0 N/A	All set-ups		FALSE	0	VisStr[18]
15-70	Option in Slot A	0 N/A	All set-ups		FALSE	0	VisStr[30]
15-71	Slot A Option SW Version	0 N/A	All set-ups		FALSE	0	VisStr[20]
15-72	Option in Slot B	0 N/A	All set-ups		FALSE	0	VisStr[30]
15-73	Slot B Option SW Version	0 N/A	All set-ups		FALSE	0	VisStr[20]
15-74	Option in Slot C0	0 N/A	All set-ups		FALSE	0	VisStr[30]
15-75	Slot C0 Option SW Version	0 N/A	All set-ups		FALSE	0	VisStr[20]
15-76	Option in Slot C1	0 N/A	All set-ups		FALSE	0	VisStr[30]
15-77	Slot C1 Option SW Version	0 N/A	All set-ups		FALSE	0	VisStr[20]
<b>15-9* Parameter Info</b>							
15-92	Defined Parameters	0 N/A	All set-ups		FALSE	0	Uint16
15-93	Modified Parameters	0 N/A	All set-ups		FALSE	0	Uint16
15-98	Drive Identification	0 N/A	All set-ups		FALSE	0	VisStr[40]
15-99	Parameter Metadata	0 N/A	All set-ups		FALSE	0	Uint16

4.3.16 16-\*\* Data Readouts

Par. No. #	Parameter description	Default value	4-set-up	FC 302 only	Change during operation	Conversion index	Type
<b>16-0* General Status</b>							
16-00	Control Word	0 N/A	All set-ups		FALSE	0	V2
16-01	Reference [Unit]	0.000 ReferenceFeed-backUnit	All set-ups		FALSE	-3	Int32
16-02	Reference %	0.0 %	All set-ups		FALSE	-1	Int16
16-03	Status Word	0 N/A	All set-ups		FALSE	0	V2
16-05	Main Actual Value [%]	0.00 %	All set-ups		FALSE	-2	N2
16-09	Custom Readout	0.00 CustomReadoutUnit	All set-ups		FALSE	-2	Int32
<b>16-1* Motor Status</b>							
16-10	Power [kW]	0.00 kW	All set-ups		FALSE	1	Int32
16-11	Power [hp]	0.00 hp	All set-ups		FALSE	-2	Int32
16-12	Motor Voltage	0.0 V	All set-ups		FALSE	-1	UInt16
16-13	Frequency	0.0 Hz	All set-ups		FALSE	-1	UInt16
16-14	Motor Current	0.00 A	All set-ups		FALSE	-2	Int32
16-15	Frequency [%]	0.00 %	All set-ups		FALSE	-2	N2
16-16	Torque [Nm]	0.0 Nm	All set-ups		FALSE	-1	Int16
16-17	Speed [RPM]	0 RPM	All set-ups		FALSE	67	Int32
16-18	Motor Thermal	0 %	All set-ups		FALSE	0	UInt8
16-19	KTY sensor temperature	0 °C	All set-ups		FALSE	100	Int16
16-20	Motor Angle	0 N/A	All set-ups		TRUE	0	UInt16
16-21	Torque [%] High Res.	0.0 %	All set-ups		FALSE	-1	Int16
16-22	Torque [%]	0 %	All set-ups		FALSE	0	Int16
16-25	Torque [Nm] High	0.0 Nm	All set-ups		FALSE	-1	Int32
<b>16-3* Drive Status</b>							
16-30	DC Link Voltage	0 V	All set-ups		FALSE	0	UInt16
16-32	Brake Energy /s	0.000 kW	All set-ups		FALSE	0	UInt32
16-33	Brake Energy /2 min	0.000 kW	All set-ups		FALSE	0	UInt32
16-34	Heatsink Temp.	0 °C	All set-ups		FALSE	100	UInt8
16-35	Inverter Thermal	0 %	All set-ups		FALSE	0	UInt8
16-36	Inv. Nom. Current	App.Dependent	All set-ups		FALSE	-2	UInt32
16-37	Inv. Max. Current	App.Dependent	All set-ups		FALSE	-2	UInt32
16-38	SL Controller State	0 N/A	All set-ups		FALSE	0	UInt8
16-39	Control Card Temp.	0 °C	All set-ups		FALSE	100	UInt8
16-40	Logging Buffer Full	[0] No	All set-ups		TRUE	-	UInt8
16-41	LCP Bottom Statusline	0 N/A	All set-ups		TRUE	0	VisStr[50]
16-49	Current Fault Source	0 N/A	All set-ups	x	TRUE	0	UInt8
<b>16-5* Ref. &amp; Feedb.</b>							
16-50	External Reference	0.0 N/A	All set-ups		FALSE	-1	Int16
16-51	Pulse Reference	0.0 N/A	All set-ups		FALSE	-1	Int16
16-52	Feedback [Unit]	0.000 ReferenceFeed-backUnit	All set-ups		FALSE	-3	Int32
16-53	Digi Pot Reference	0.00 N/A	All set-ups		FALSE	-2	Int16
16-57	Feedback [RPM]	0 RPM	All set-ups		FALSE	67	Int32

Par. No. #	Parameter description	Default value	4-set-up	FC 302 only	Change during operation	Conversion index	Type
<b>16-6* Inputs &amp; Outputs</b>							
16-60	Digital Input	0 N/A	All set-ups		FALSE	0	Uint16
16-61	Terminal 53 Switch Setting	[0] Current	All set-ups		FALSE	-	Uint8
16-62	Analog Input 53	0.000 N/A	All set-ups		FALSE	-3	Int32
16-63	Terminal 54 Switch Setting	[0] Current	All set-ups		FALSE	-	Uint8
16-64	Analog Input 54	0.000 N/A	All set-ups		FALSE	-3	Int32
16-65	Analog Output 42 [mA]	0.000 N/A	All set-ups		FALSE	-3	Int16
16-66	Digital Output [bin]	0 N/A	All set-ups		FALSE	0	Int16
16-67	Freq. Input #29 [Hz]	0 N/A	All set-ups	x	FALSE	0	Int32
16-68	Freq. Input #33 [Hz]	0 N/A	All set-ups		FALSE	0	Int32
16-69	Pulse Output #27 [Hz]	0 N/A	All set-ups		FALSE	0	Int32
16-70	Pulse Output #29 [Hz]	0 N/A	All set-ups	x	FALSE	0	Int32
16-71	Relay Output [bin]	0 N/A	All set-ups		FALSE	0	Int16
16-72	Counter A	0 N/A	All set-ups		TRUE	0	Int32
16-73	Counter B	0 N/A	All set-ups		TRUE	0	Int32
16-74	Prec. Stop Counter	0 N/A	All set-ups		TRUE	0	Uint32
16-75	Analog In X30/11	0.000 N/A	All set-ups		FALSE	-3	Int32
16-76	Analog In X30/12	0.000 N/A	All set-ups		FALSE	-3	Int32
16-77	Analog Out X30/8 [mA]	0.000 N/A	All set-ups		FALSE	-3	Int16
16-78	Analog Out X45/1 [mA]	0.000 N/A	All set-ups		FALSE	-3	Int16
16-79	Analog Out X45/3 [mA]	0.000 N/A	All set-ups		FALSE	-3	Int16
<b>16-8* Fieldbus &amp; FC Port</b>							
16-80	Fieldbus CTW 1	0 N/A	All set-ups		FALSE	0	V2
16-82	Fieldbus REF 1	0 N/A	All set-ups		FALSE	0	N2
16-84	Comm. Option STW	0 N/A	All set-ups		FALSE	0	V2
16-85	FC Port CTW 1	0 N/A	All set-ups		FALSE	0	V2
16-86	FC Port REF 1	0 N/A	All set-ups		FALSE	0	N2
<b>16-9* Diagnosis Readouts</b>							
16-90	Alarm Word	0 N/A	All set-ups		FALSE	0	Uint32
16-91	Alarm Word 2	0 N/A	All set-ups		FALSE	0	Uint32
16-92	Warning Word	0 N/A	All set-ups		FALSE	0	Uint32
16-93	Warning Word 2	0 N/A	All set-ups		FALSE	0	Uint32
16-94	Ext. Status Word	0 N/A	All set-ups		FALSE	0	Uint32

## 4.3.17 17-\*\* Motor Feedb.Option

Par. No. #	Parameter description	Default value	4-set-up	FC 302 only	Change during operation	Conversion index	Type
<b>17-1* Inc. Enc. Interface</b>							
17-10	Signal Type	[1] RS422 (5V TTL)	All set-ups		FALSE	-	Uint8
17-11	Resolution (PPR)	1024 N/A	All set-ups		FALSE	0	Uint16
<b>17-2* Abs. Enc. Interface</b>							
17-20	Protocol Selection	[0] None	All set-ups		FALSE	-	Uint8
17-21	Resolution (Positions/Rev)	App.Dependent	All set-ups		FALSE	0	Uint32
17-24	SSI Data Length	13 N/A	All set-ups		FALSE	0	Uint8
17-25	Clock Rate	App.Dependent	All set-ups		FALSE	3	Uint16
17-26	SSI Data Format	[0] Gray code	All set-ups		FALSE	-	Uint8
17-34	HIPERFACE Baudrate	[4] 9600	All set-ups		FALSE	-	Uint8
<b>17-5* Resolver Interface</b>							
17-50	Poles	2 N/A	1 set-up		FALSE	0	Uint8
17-51	Input Voltage	7.0 V	1 set-up		FALSE	-1	Uint8
17-52	Input Frequency	10.0 kHz	1 set-up		FALSE	2	Uint8
17-53	Transformation Ratio	0.5 N/A	1 set-up		FALSE	-1	Uint8
17-56	Encoder Sim. Resolution	[0] Disabled	1 set-up		FALSE	-	Uint8
17-59	Resolver Interface	[0] Disabled	All set-ups		FALSE	-	Uint8
<b>17-6* Monitoring and App.</b>							
17-60	Feedback Direction	[0] Clockwise	All set-ups		FALSE	-	Uint8
17-61	Feedback Signal Monitoring	[1] Warning	All set-ups		TRUE	-	Uint8

## 4.3.18 18-\*\* Data Readouts 2

Par. No. #	Parameter description	Default value	4-set-up	FC 302 only	Change during operation	Conversion index	Type
<b>18-3* Analog Readouts</b>							
18-36	Analog Input X48/2 [mA]	0.000 N/A	All set-ups		TRUE	-3	Int32
18-37	Temp. Input X48/4	0 N/A	All set-ups		TRUE	0	Int16
18-38	Temp. Input X48/7	0 N/A	All set-ups		TRUE	0	Int16
18-39	Temp. Input X48/10	0 N/A	All set-ups		TRUE	0	Int16
<b>18-6* Inputs &amp; Outputs 2</b>							
18-60	Digital Input 2	0 N/A	All set-ups		FALSE	0	UInt16
<b>18-90 PID Readouts</b>							
18-90	Process PID Error	0.0 %	All set-ups		FALSE	-1	Int16
18-91	Process PID Output	0.0 %	All set-ups		FALSE	-1	Int16
18-92	Process PID Clamped Output	0.0 %	All set-ups		FALSE	-1	Int16
18-93	Process PID Gain Scaled Output	0.0 %	All set-ups		FALSE	-1	Int16

## 4.3.19 30-\*\* Special Features

Par. No. #	Parameter description	Default value	4-set-up	FC 302 only	Change during operation	Conversion index	Type
<b>30-0* Wobbler</b>							
30-00	Wobble Mode	[0] Abs. Freq., Abs. Time	All set-ups		FALSE	-	Uint8
30-01	Wobble Delta Frequency [Hz]	5.0 Hz	All set-ups		TRUE	-1	Uint8
30-02	Wobble Delta Frequency [%]	25 %	All set-ups		TRUE	0	Uint8
30-03	Wobble Delta Freq. Scaling Resource	[0] No function	All set-ups		TRUE	-	Uint8
30-04	Wobble Jump Frequency [Hz]	0.0 Hz	All set-ups		TRUE	-1	Uint8
30-05	Wobble Jump Frequency [%]	0 %	All set-ups		TRUE	0	Uint8
30-06	Wobble Jump Time	App.Dependent	All set-ups		TRUE	-3	Uint16
30-07	Wobble Sequence Time	10.0 s	All set-ups		TRUE	-1	Uint16
30-08	Wobble Up/ Down Time	5.0 s	All set-ups		TRUE	-1	Uint16
30-09	Wobble Random Function	[0] Off	All set-ups		TRUE	-	Uint8
30-10	Wobble Ratio	1.0 N/A	All set-ups		TRUE	-1	Uint8
30-11	Wobble Random Ratio Max.	10.0 N/A	All set-ups		TRUE	-1	Uint8
30-12	Wobble Random Ratio Min.	0.1 N/A	All set-ups		TRUE	-1	Uint8
30-19	Wobble Delta Freq. Scaled	0.0 Hz	All set-ups		FALSE	-1	Uint16
<b>30-2* Adv. Start Adjust</b>							
30-20	High Starting Torque Time [s]	0.00 s	All set-ups	x	TRUE	-2	Uint8
30-21	High Starting Torque Current [%]	100.0 %	All set-ups	x	TRUE	-1	Uint32
30-22	Locked Rotor Protection	[0] Off	All set-ups	x	TRUE	-	Uint8
30-23	Locked Rotor Detection Time [s]	0.10 s	All set-ups	x	TRUE	-2	Uint8
<b>30-8* Compatibility (I)</b>							
30-80	d-axis Inductance (Ld)	App.Dependent	All set-ups	x	FALSE	-6	Int32
30-81	Brake Resistor (ohm)	App.Dependent	1 set-up		TRUE	-2	Uint32
30-83	Speed PID Proportional Gain	App.Dependent	All set-ups		TRUE	-4	Uint32
30-84	Process PID Proportional Gain	0.100 N/A	All set-ups		TRUE	-3	Uint16

## 4.3.20 32-\*\* MCO Basic Settings

4

Par. No. #	Parameter description	Default value	4-set-up	FC 302 only	Change during operation	Conversion index	Type
<b>32-0* Encoder 2</b>							
32-00	Incremental Signal Type	[1] RS422 (5V TTL)	2 set-ups		TRUE	-	Uint8
32-01	Incremental Resolution	1024 N/A	2 set-ups		TRUE	0	Uint32
32-02	Absolute Protocol	[0] None	2 set-ups		TRUE	-	Uint8
32-03	Absolute Resolution	8192 N/A	2 set-ups		TRUE	0	Uint32
32-04	Absolute Encoder Baudrate X55	[4] 9600	All set-ups		FALSE	-	Uint8
32-05	Absolute Encoder Data Length	25 N/A	2 set-ups		TRUE	0	Uint8
32-06	Absolute Encoder Clock Frequency	262.000 kHz	2 set-ups		TRUE	0	Uint32
32-07	Absolute Encoder Clock Generation	[1] On	2 set-ups		TRUE	-	Uint8
32-08	Absolute Encoder Cable Length	0 m	2 set-ups		TRUE	0	Uint16
32-09	Encoder Monitoring	[0] Off	2 set-ups		TRUE	-	Uint8
32-10	Rotational Direction	[1] No action	2 set-ups		TRUE	-	Uint8
32-11	User Unit Denominator	1 N/A	2 set-ups		TRUE	0	Uint32
32-12	User Unit Numerator	1 N/A	2 set-ups		TRUE	0	Uint32
32-13	Enc.2 Control	[0] No soft changing	2 set-ups		TRUE	-	Uint8
32-14	Enc.2 node ID	127 N/A	2 set-ups		TRUE	0	Uint8
32-15	Enc.2 CAN guard	null	2 set-ups		TRUE	-	Uint8
<b>32-3* Encoder 1</b>							
32-30	Incremental Signal Type	[1] RS422 (5V TTL)	2 set-ups		TRUE	-	Uint8
32-31	Incremental Resolution	1024 N/A	2 set-ups		TRUE	0	Uint32
32-32	Absolute Protocol	[0] None	2 set-ups		TRUE	-	Uint8
32-33	Absolute Resolution	8192 N/A	2 set-ups		TRUE	0	Uint32
32-35	Absolute Encoder Data Length	25 N/A	2 set-ups		TRUE	0	Uint8
32-36	Absolute Encoder Clock Frequency	262.000 kHz	2 set-ups		TRUE	0	Uint32
32-37	Absolute Encoder Clock Generation	[1] On	2 set-ups		TRUE	-	Uint8
32-38	Absolute Encoder Cable Length	0 m	2 set-ups		TRUE	0	Uint16
32-39	Encoder Monitoring	[0] Off	2 set-ups		TRUE	-	Uint8
32-40	Encoder Termination	[1] On	2 set-ups		TRUE	-	Uint8
32-43	Enc.1 Control	[0] No soft changing	2 set-ups		TRUE	-	Uint8
32-44	Enc.1 node ID	127 N/A	2 set-ups		TRUE	0	Uint8
32-45	Enc.1 CAN guard	null	2 set-ups		TRUE	-	Uint8
<b>32-5* Feedback Source</b>							
32-50	Source Slave	[2] Encoder 2	2 set-ups		TRUE	-	Uint8
32-51	MCO 302 Last Will	[1] Trip	2 set-ups		TRUE	-	Uint8
32-52	Source Master	[1] Encoder 1 X56	2 set-ups		TRUE	-	Uint8



Par. No. #	Parameter description	Default value	4-set-up	FC 302 only	Change during operation	Conversion index	Type
<b>32-6* PID Controller</b>							
32-60	Proportional factor	30 N/A	2 set-ups		TRUE	0	Uint32
32-61	Derivative factor	0 N/A	2 set-ups		TRUE	0	Uint32
32-62	Integral factor	0 N/A	2 set-ups		TRUE	0	Uint32
32-63	Limit Value for Integral Sum	1000 N/A	2 set-ups		TRUE	0	Uint16
32-64	PID Bandwidth	1000 N/A	2 set-ups		TRUE	0	Uint16
32-65	Velocity Feed-Forward	0 N/A	2 set-ups		TRUE	0	Uint32
32-66	Acceleration Feed-Forward	0 N/A	2 set-ups		TRUE	0	Uint32
32-67	Max. Tolerated Position Error	20000 N/A	2 set-ups		TRUE	0	Uint32
32-68	Reverse Behavior for Slave	[0] Reversing allowed	2 set-ups		TRUE	-	Uint8
32-69	Sampling Time for PID Control	1 ms	2 set-ups		TRUE	-3	Uint16
32-70	Scan Time for Profile Generator	1 ms	2 set-ups		TRUE	-3	Uint8
32-71	Size of the Control Window (Activation)	0 N/A	2 set-ups		TRUE	0	Uint32
32-72	Size of the Control Window (Deactiv.)	0 N/A	2 set-ups		TRUE	0	Uint32
32-73	Integral limit filter time	0 ms	2 set-ups		TRUE	-3	Int16
32-74	Position error filter time	0 ms	2 set-ups		TRUE	-3	Int16
<b>32-8* Velocity &amp; Accel.</b>							
32-80	Maximum Velocity (Encoder)	1500 RPM	2 set-ups		TRUE	67	Uint32
32-81	Shortest Ramp	1.000 s	2 set-ups		TRUE	-3	Uint32
32-82	Ramp Type	[0] Linear	2 set-ups		TRUE	-	Uint8
32-83	Velocity Resolution	100 N/A	2 set-ups		TRUE	0	Uint32
32-84	Default Velocity	50 N/A	2 set-ups		TRUE	0	Uint32
32-85	Default Acceleration	50 N/A	2 set-ups		TRUE	0	Uint32
32-86	Acc. up for limited jerk	100 ms	2 set-ups		TRUE	-3	Uint32
32-87	Acc. down for limited jerk	0 ms	2 set-ups		TRUE	-3	Uint32
32-88	Dec. up for limited jerk	0 ms	2 set-ups		TRUE	-3	Uint32
32-89	Dec. down for limited jerk	0 ms	2 set-ups		TRUE	-3	Uint32
<b>32-9* Development</b>							
32-90	Debug Source	[0] Controlcard	2 set-ups		TRUE	-	Uint8

## 4.3.21 33-\*\* MCO Adv. Settings

Par. No. #	Parameter description	Default value	4-set-up	FC 302 only	Change during operation	Conversion index	Type
<b>33-0* Home Motion</b>							
33-00	Force HOME	[0] Home not forced	2 set-ups		TRUE	-	UInt8
33-01	Zero Point Offset from Home Pos.	0 N/A	2 set-ups		TRUE	0	Int32
33-02	Ramp for Home Motion	10 N/A	2 set-ups		TRUE	0	UInt32
33-03	Velocity of Home Motion	10 N/A	2 set-ups		TRUE	0	Int32
33-04	Behaviour during HomeMotion	[0] Revers and index	2 set-ups		TRUE	-	UInt8
<b>33-1* Synchronization</b>							
33-10	Sync Factor Master	1 N/A	2 set-ups		TRUE	0	Int32
33-11	Sync Factor Slave	1 N/A	2 set-ups		TRUE	0	Int32
33-12	Position Offset for Synchronization	0 N/A	2 set-ups		TRUE	0	Int32
33-13	Accuracy Window for Position Sync.	1000 N/A	2 set-ups		TRUE	0	Int32
33-14	Relative Slave Velocity Limit	0 %	2 set-ups		TRUE	0	UInt8
33-15	Marker Number for Master	1 N/A	2 set-ups		TRUE	0	UInt16
33-16	Marker Number for Slave	1 N/A	2 set-ups		TRUE	0	UInt16
33-17	Master Marker Distance	4096 N/A	2 set-ups		TRUE	0	UInt32
33-18	Slave Marker Distance	4096 N/A	2 set-ups		TRUE	0	UInt32
33-19	Master Marker Type	[0] Encoder Z positive	2 set-ups		TRUE	-	UInt8
33-20	Slave Marker Type	[0] Encoder Z positive	2 set-ups		TRUE	-	UInt8
33-21	Master Marker Tolerance Window	0 N/A	2 set-ups		TRUE	0	UInt32
33-22	Slave Marker Tolerance Window	0 N/A	2 set-ups		TRUE	0	UInt32
33-23	Start Behaviour for Marker Sync	[0] Start Function 1	2 set-ups		TRUE	-	UInt16
33-24	Marker Number for Fault	10 N/A	2 set-ups		TRUE	0	UInt16
33-25	Marker Number for Ready	1 N/A	2 set-ups		TRUE	0	UInt16
33-26	Velocity Filter	0 us	2 set-ups		TRUE	-6	Int32
33-27	Offset Filter Time	0 ms	2 set-ups		TRUE	-3	UInt32
33-28	Marker Filter Configuration	[0] Marker filter 1	2 set-ups		TRUE	-	UInt8
33-29	Filter Time for Marker Filter	0 ms	2 set-ups		TRUE	-3	Int32
33-30	Maximum Marker Correction	0 N/A	2 set-ups		TRUE	0	UInt32
33-31	Synchronisation Type	[0] Standard	2 set-ups		TRUE	-	UInt8
33-32	Feed Forward Velocity Adaptation	0 N/A	2 set-ups		TRUE	0	UInt32
33-33	Velocity Filter Window	0 N/A	2 set-ups		TRUE	0	UInt32
33-34	Slave Marker filter time	0 ms	2 set-ups		TRUE	-3	UInt32
<b>33-4* Limit Handling</b>							
33-40	Behaviour at End Limit Switch	[0] Call error handler	2 set-ups		TRUE	-	UInt8
33-41	Negative Software End Limit	-500000 N/A	2 set-ups		TRUE	0	Int32
33-42	Positive Software End Limit	500000 N/A	2 set-ups		TRUE	0	Int32
33-43	Negative Software End Limit Active	[0] Inactive	2 set-ups		TRUE	-	UInt8
33-44	Positive Software End Limit Active	[0] Inactive	2 set-ups		TRUE	-	UInt8
33-45	Time in Target Window	0 ms	2 set-ups		TRUE	-3	UInt8
33-46	Target Window LimitValue	1 N/A	2 set-ups		TRUE	0	UInt16
33-47	Size of Target Window	0 N/A	2 set-ups		TRUE	0	UInt16

Par. No. #	Parameter description	Default value	4-set-up	FC 302 only	Change during operation	Conversion index	Type
<b>33-5* I/O Configuration</b>							
33-50	Terminal X57/1 Digital Input	[0] No function	2 set-ups		TRUE	-	Uint8
33-51	Terminal X57/2 Digital Input	[0] No function	2 set-ups		TRUE	-	Uint8
33-52	Terminal X57/3 Digital Input	[0] No function	2 set-ups		TRUE	-	Uint8
33-53	Terminal X57/4 Digital Input	[0] No function	2 set-ups		TRUE	-	Uint8
33-54	Terminal X57/5 Digital Input	[0] No function	2 set-ups		TRUE	-	Uint8
33-55	Terminal X57/6 Digital Input	[0] No function	2 set-ups		TRUE	-	Uint8
33-56	Terminal X57/7 Digital Input	[0] No function	2 set-ups		TRUE	-	Uint8
33-57	Terminal X57/8 Digital Input	[0] No function	2 set-ups		TRUE	-	Uint8
33-58	Terminal X57/9 Digital Input	[0] No function	2 set-ups		TRUE	-	Uint8
33-59	Terminal X57/10 Digital Input	[0] No function	2 set-ups		TRUE	-	Uint8
33-60	Terminal X59/1 and X59/2 Mode	[1] Output	2 set-ups		FALSE	-	Uint8
33-61	Terminal X59/1 Digital Input	[0] No function	2 set-ups		TRUE	-	Uint8
33-62	Terminal X59/2 Digital Input	[0] No function	2 set-ups		TRUE	-	Uint8
33-63	Terminal X59/1 Digital Output	[0] No function	2 set-ups		TRUE	-	Uint8
33-64	Terminal X59/2 Digital Output	[0] No function	2 set-ups		TRUE	-	Uint8
33-65	Terminal X59/3 Digital Output	[0] No function	2 set-ups		TRUE	-	Uint8
33-66	Terminal X59/4 Digital Output	[0] No function	2 set-ups		TRUE	-	Uint8
33-67	Terminal X59/5 Digital Output	[0] No function	2 set-ups		TRUE	-	Uint8
33-68	Terminal X59/6 Digital Output	[0] No function	2 set-ups		TRUE	-	Uint8
33-69	Terminal X59/7 Digital Output	[0] No function	2 set-ups		TRUE	-	Uint8
33-70	Terminal X59/8 Digital Output	[0] No function	2 set-ups		TRUE	-	Uint8
<b>33-8* Global Parameters</b>							
33-80	Activated Program Number	-1 N/A	2 set-ups		TRUE	0	Int8
33-81	Power-up State	[1] Motor on	2 set-ups		TRUE	-	Uint8
33-82	Drive Status Monitoring	[1] On	2 set-ups		TRUE	-	Uint8
33-83	Behaviour afterError	[0] Coast	2 set-ups		TRUE	-	Uint8
33-84	Behaviour afterEsc.	[0] Controlled stop	2 set-ups		TRUE	-	Uint8
33-85	MCO Supplied by External 24VDC	[0] No	2 set-ups		TRUE	-	Uint8
33-86	Terminal at alarm	[0] Relay 1	2 set-ups		TRUE	-	Uint8
33-87	Terminal state at alarm	[0] Do nothing	2 set-ups		TRUE	-	Uint8
33-88	Status word at alarm	0 N/A	2 set-ups		TRUE	0	Uint16
<b>33-9* MCO Port Settings</b>							
33-90	X62 MCO CAN node ID	127 N/A	2 set-ups		TRUE	0	Uint8
33-91	X62 MCO CAN baud rate	[20] 125 Kbps	2 set-ups		TRUE	-	Uint8
33-94	X60 MCO RS485 serial termination	[0] Off	2 set-ups		TRUE	-	Uint8
33-95	X60 MCO RS485 serial baud rate	[2] 9600 Baud	2 set-ups		TRUE	-	Uint8

## 4.3.22 34-\*\* MCO Data Readouts

4

Par. No. #	Parameter description	Default value	4-set-up	FC 302 only	Change during operation	Conversion index	Type
<b>34-0* PCD Write Par.</b>							
34-01	PCD 1 Write to MCO	0 N/A	All set-ups		TRUE	0	Uint16
34-02	PCD 2 Write to MCO	0 N/A	All set-ups		TRUE	0	Uint16
34-03	PCD 3 Write to MCO	0 N/A	All set-ups		TRUE	0	Uint16
34-04	PCD 4 Write to MCO	0 N/A	All set-ups		TRUE	0	Uint16
34-05	PCD 5 Write to MCO	0 N/A	All set-ups		TRUE	0	Uint16
34-06	PCD 6 Write to MCO	0 N/A	All set-ups		TRUE	0	Uint16
34-07	PCD 7 Write to MCO	0 N/A	All set-ups		TRUE	0	Uint16
34-08	PCD 8 Write to MCO	0 N/A	All set-ups		TRUE	0	Uint16
34-09	PCD 9 Write to MCO	0 N/A	All set-ups		TRUE	0	Uint16
34-10	PCD 10 Write to MCO	0 N/A	All set-ups		TRUE	0	Uint16
<b>34-2* PCD Read Par.</b>							
34-21	PCD 1 Read from MCO	0 N/A	All set-ups		TRUE	0	Uint16
34-22	PCD 2 Read from MCO	0 N/A	All set-ups		TRUE	0	Uint16
34-23	PCD 3 Read from MCO	0 N/A	All set-ups		TRUE	0	Uint16
34-24	PCD 4 Read from MCO	0 N/A	All set-ups		TRUE	0	Uint16
34-25	PCD 5 Read from MCO	0 N/A	All set-ups		TRUE	0	Uint16
34-26	PCD 6 Read from MCO	0 N/A	All set-ups		TRUE	0	Uint16
34-27	PCD 7 Read from MCO	0 N/A	All set-ups		TRUE	0	Uint16
34-28	PCD 8 Read from MCO	0 N/A	All set-ups		TRUE	0	Uint16
34-29	PCD 9 Read from MCO	0 N/A	All set-ups		TRUE	0	Uint16
34-30	PCD 10 Read from MCO	0 N/A	All set-ups		TRUE	0	Uint16
<b>34-4* Inputs &amp; Outputs</b>							
34-40	Digital Inputs	0 N/A	All set-ups		TRUE	0	Uint16
34-41	Digital Outputs	0 N/A	All set-ups		TRUE	0	Uint16
<b>34-5* Process Data</b>							
34-50	Actual Position	0 N/A	All set-ups		TRUE	0	Int32
34-51	Commanded Position	0 N/A	All set-ups		TRUE	0	Int32
34-52	Actual Master Position	0 N/A	All set-ups		TRUE	0	Int32
34-53	Slave Index Position	0 N/A	All set-ups		TRUE	0	Int32
34-54	Master Index Position	0 N/A	All set-ups		TRUE	0	Int32
34-55	Curve Position	0 N/A	All set-ups		TRUE	0	Int32
34-56	Track Error	0 N/A	All set-ups		TRUE	0	Int32
34-57	Synchronizing Error	0 N/A	All set-ups		TRUE	0	Int32
34-58	Actual Velocity	0 N/A	All set-ups		TRUE	0	Int32
34-59	Actual Master Velocity	0 N/A	All set-ups		TRUE	0	Int32
34-60	Synchronizing Status	0 N/A	All set-ups		TRUE	0	Int32
34-61	Axis Status	0 N/A	All set-ups		TRUE	0	Int32
34-62	Program Status	0 N/A	All set-ups		TRUE	0	Int32
34-64	MCO 302 Status	0 N/A	All set-ups		TRUE	0	Uint16
34-65	MCO 302 Control	0 N/A	All set-ups		TRUE	0	Uint16
<b>34-7* Diagnosis readouts</b>							
34-70	MCO Alarm Word 1	0 N/A	All set-ups		FALSE	0	Uint32
34-71	MCO Alarm Word 2	0 N/A	All set-ups		FALSE	0	Uint32

## 4.3.23 35-\*\* Sensor Input Option

Par. No. #	Parameter description	Default value	4-set-up	FC 302 only	Change during operation	Conversion index	Type
<b>35-0* Temp. Input Mode</b>							
35-00	Term. X48/4 Temp. Unit	[60] °C	All set-ups		TRUE	-	Uint8
35-01	Term. X48/4 Input Type	[0] Not Connected	All set-ups		TRUE	-	Uint8
35-02	Term. X48/7 Temp. Unit	[60] °C	All set-ups		TRUE	-	Uint8
35-03	Term. X48/7 Input Type	[0] Not Connected	All set-ups		TRUE	-	Uint8
35-04	Term. X48/10 Temp. Unit	[60] °C	All set-ups		TRUE	-	Uint8
35-05	Term. X48/10 Input Type	[0] Not Connected	All set-ups		TRUE	-	Uint8
35-06	Temperature Sensor Alarm Function	[5] Stop and trip	All set-ups		TRUE	-	Uint8
<b>35-1* Temp. Input X48/4</b>							
35-14	Term. X48/4 Filter Time Constant	0.001 s	All set-ups		TRUE	-3	Uint16
35-15	Term. X48/4 Temp. Monitor	[0] Disabled	All set-ups		TRUE	-	Uint8
35-16	Term. X48/4 Low Temp. Limit	App.Dependent	All set-ups		TRUE	0	Int16
35-17	Term. X48/4 High Temp. Limit	App.Dependent	All set-ups		TRUE	0	Int16
<b>35-2* Temp. Input X48/7</b>							
35-24	Term. X48/7 Filter Time Constant	0.001 s	All set-ups		TRUE	-3	Uint16
35-25	Term. X48/7 Temp. Monitor	[0] Disabled	All set-ups		TRUE	-	Uint8
35-26	Term. X48/7 Low Temp. Limit	App.Dependent	All set-ups		TRUE	0	Int16
35-27	Term. X48/7 High Temp. Limit	App.Dependent	All set-ups		TRUE	0	Int16
<b>35-3* Temp. Input X48/10</b>							
35-34	Term. X48/10 Filter Time Constant	0.001 s	All set-ups		TRUE	-3	Uint16
35-35	Term. X48/10 Temp. Monitor	[0] Disabled	All set-ups		TRUE	-	Uint8
35-36	Term. X48/10 Low Temp. Limit	App.Dependent	All set-ups		TRUE	0	Int16
35-37	Term. X48/10 High Temp. Limit	App.Dependent	All set-ups		TRUE	0	Int16
<b>35-4* Analog Input X48/2</b>							
35-42	Term. X48/2 Low Current	4.00 mA	All set-ups		TRUE	-5	Int16
35-43	Term. X48/2 High Current	20.00 mA	All set-ups		TRUE	-5	Int16
35-44	Term. X48/2 Low Ref./Feedb. Value	0.000 N/A	All set-ups		TRUE	-3	Int32
35-45	Term. X48/2 High Ref./Feedb. Value	100.000 N/A	All set-ups		TRUE	-3	Int32
35-46	Term. X48/2 Filter Time Constant	0.001 s	All set-ups		TRUE	-3	Uint16

## 5 General Specifications

### Mains supply (L1-1, L2-1, L3-1, L1-2, L2-2, L3-2)

Supply voltage	FC 302: 380-500 V ±10%
Supply voltage	FC 302: 525-690 V ±10%

#### Mains voltage low / mains drop-out:

During low mains voltage or a mains drop-out, the frequency converter continues until the intermediate circuit voltage drops below the minimum stop level, which corresponds typically to 15% below the lowest rated supply voltage. Power-up and full torque cannot be expected at mains voltage lower than 10% below the lowest rated supply voltage.

Supply frequency	50/60 Hz ±5%
Max. imbalance temporary between mains phases	3.0% of rated supply voltage
True Power Factor ( $\lambda$ )	≥ 0.9 nominal at rated load
Displacement Power Factor (cos $\phi$ ) near unity	(> 0.98)
Switching on input supply L1-1, L2-1, L3-1, L1-2, L2-2, L3-2 (power-ups)	maximum 1 time/2 min.
Environment according to EN60664-1	over-voltage category III/pollution degree 2

The unit is suitable for use on a circuit capable of delivering not more than 100.000 RMS symmetrical Amperes, 500/600/690V maximum.

### Motor output (U, V, W)

Output voltage	0 - 100% of supply voltage
Output frequency	0 - 800* Hz
Switching on output	Unlimited
Ramp times	0.01 - 3600 s

\* Voltage and power dependent

### Torque characteristics

Starting torque (Constant torque)	maximum 160% for 60 s <sup>1)</sup>
Starting torque	maximum 180% up to 0.5 s <sup>1)</sup>
Overload torque (Constant torque)	maximum 160% for 60 s <sup>1)</sup>
Starting torque (Variable torque)	maximum 110% for 60 s <sup>1)</sup>
Overload torque (Variable torque)	maximum 110% for 60 s

Torque rise time in (independent of fsw)	10 ms
Torque rise time in FLUX (for 5 kHz fsw)	1 ms

<sup>1)</sup> Percentage relates to the nominal torque.

<sup>2)</sup> The torque response time depends on application and load but as a general rule, the torque step from 0 to reference is 4-5 x torque rise time.

### Digital inputs

Programmable digital inputs	4 (6)
Terminal number	18, 19, 27 <sup>1)</sup> , 29, 32, 33,
Logic	PNP or NPN
Voltage level	0 - 24 V DC
Voltage level, logic '0' PNP	< 5 V DC
Voltage level, logic '1' PNP	> 10 V DC
Voltage level, logic '0' NPN <sup>2)</sup>	> 19 V DC
Voltage level, logic '1' NPN <sup>2)</sup>	< 14 V DC
Maximum voltage on input	28 V DC
Pulse frequency range	0 - 110 kHz
(Duty cycle) Min. pulse width	4.5 ms
Input resistance, R <sub>i</sub>	approx.4 k $\Omega$

Safe stop Terminal 37<sup>3)</sup> (Terminal 37 is fixed PNP logic)

Voltage level	0 - 24 V DC
Voltage level, logic'0' PNP	< 4 V DC
Voltage level, logic'1' PNP	>20 V DC
Nominal input current at 24 V	50 mA rms
Nominal input current at 20 V	60 mA rms
Input capacitance	400 nF

All digital inputs are galvanically isolated from the supply voltage (PELV) and other high-voltage terminals.

1) Terminals 27 and 29 can also be programmed as output.

2) Except safe stop input Terminal 37.

3) Terminal 37 can only be used as safe stop input. Terminal 37 is suitable for category 3 2006/42/EC installations according to EN 954-1, PL d acc. EN ISO 13849-1 and SIL 2 acc. EN 62061 (safe stop according to category 0 EN 60204-1) as required by the EU Machinery Directive 98/37/EC. Terminal 37 and the Safe Stop function are designed in conformance with EN 60204-1, EN 50178, EN 61800-5-2, EN 62061, EN ISO 1384 and EN 954-1. For correct and safe use of the Safe Stop function follow the related information and instructions in the VLT Automation Drive Design Guide, MG33BXYY.

Analog inputs

Number of analog inputs	2
Terminal number	53, 54
Modes	Voltage or current
Mode select	Switch S201 and switch S202
Voltage mode	Switch S201/switch S202 = OFF (U)
Voltage level	-10 to +10 V (scaleable)
Input resistance, R <sub>i</sub>	approx. 10 kΩ
Max. voltage	± 20 V
Current mode	Switch S201/switch S202 = ON (I)
Current level	0/4 to 20 mA (scaleable)
Input resistance, R <sub>i</sub>	approx. 200 Ω
Max. current	30 mA
Resolution for analog inputs	10 bit (+ sign)
Accuracy of analog inputs	Max. error 0.5% of full scale
Bandwidth	100 Hz

The analog inputs are galvanically isolated from the supply voltage (PELV) and other high-voltage terminals.

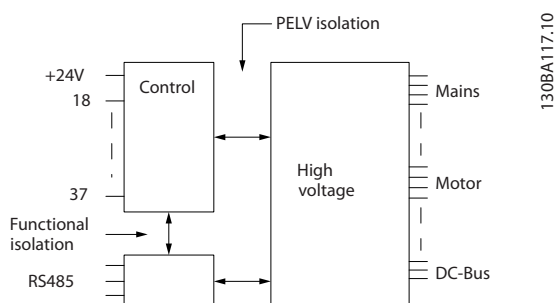

**Pulse/encoder inputs**

Programmable pulse/encoder inputs	2/1
Terminal number pulse/encoder	29 <sup>1)</sup> , 33 <sup>2)</sup> / 32 <sup>3)</sup> , 33 <sup>3)</sup>
Max. frequency at terminal 29, 32, 33	110 kHz (Push-pull driven)
Max. frequency at terminal 29, 32, 33	5 kHz (open collector)
Min. frequency at terminal 29, 32, 33	4 Hz
Voltage level	see
Maximum voltage on input	28 V DC
Input resistance, R <sub>i</sub>	approx. 4 kΩ
Pulse input accuracy (0.1 - 1 kHz)	Max. error: 0.1% of full scale
Encoder input accuracy (1 - 11 kHz)	Max. error: 0.05 % of full scale

*The pulse and encoder inputs (terminals 29, 32, 33) are galvanically isolated from the supply voltage (PELV) and other high-voltage terminals.*

<sup>1)</sup> FC 302 only

<sup>2)</sup> Pulse inputs are 29 and 33

<sup>3)</sup> Encoder inputs: 32 = A, and 33 = B

**Digital output**

Programmable digital/pulse outputs	2
Terminal number	27, 29 <sup>1)</sup>
Voltage level at digital/frequency output	0 - 24 V
Max. output current (sink or source)	40 mA
Max. load at frequency output	1 kΩ
Max. capacitive load at frequency output	10 nF
Minimum output frequency at frequency output	0 Hz
Maximum output frequency at frequency output	32 kHz
Accuracy of frequency output	Max. error: 0.1 % of full scale
Resolution of frequency outputs	12 bit

<sup>1)</sup> Terminal 27 and 29 can also be programmed as input.

*The digital output is galvanically isolated from the supply voltage (PELV) and other high-voltage terminals.*

**Analog output**

Number of programmable analog outputs	1
Terminal number	42
Current range at analog output	0/4 - 20 mA
Max. load GND - analog output	500 Ω
Accuracy on analog output	Max. error: 0.5% of full scale
Resolution on analog output	12 bit

*The analogue output is galvanically isolated from the supply voltage (PELV) and other high-voltage terminals.*

**Control card, 24 V DC output**

Terminal number	12, 13
Output voltage	24 V +1, -3V
Max. load	200 mA

*The 24 V DC supply is galvanically isolated from the supply voltage (PELV), but has the same potential as the analog and digital inputs and outputs.*

**Control card, 10 V DC output**

Terminal number	50
Output voltage	10.5 V±0.5 V
Max. load	15 mA

*The 10 V DC supply is galvanically isolated from the supply voltage (PELV) and other high-voltage terminals.*



**Control card, RS-485 serial communication**

Terminal number	68 (P,TX+, RX+), 69 (N,TX-, RX-)
Terminal number 61	Common for terminals 68 and 69

The RS-485 serial communication circuit is functionally separated from other central circuits and galvanically isolated from the supply voltage (PELV).

**Control card, USB serial communication**

USB standard	1.1 (Full speed)
USB plug	USB type B "device" plug

Connection to PC is carried out via a standard host/device USB cable.

The USB connection is galvanically isolated from the supply voltage (PELV) and other high-voltage terminals.

The USB ground connection is not galvanically isolated from protection earth. Use only an isolated laptop as PC connection to the USB connector on the frequency converter.

**Relay outputs**

Programmable relay outputs	2
Relay 01 Terminal number	1-3 (break), 1-2 (make)
Max. terminal load (AC-1) <sup>1)</sup> on 1-3 (NC), 1-2 (NO) (Resistive load)	240 V AC, 2 A
Max. terminal load (AC-15) <sup>1)</sup> (Inductive load @ cosφ 0.4)	240 V AC, 0.2 A
Max. terminal load (DC-1) <sup>1)</sup> on 1-2 (NO), 1-3 (NC) (Resistive load)	60 V DC, 1 A
Max. terminal load (DC-13) <sup>1)</sup> (Inductive load)	24 V DC, 0.1 A
Relay 02 (FC 302 only) Terminal number	4-6 (break), 4-5 (make)
Max. terminal load (AC-1) <sup>1)</sup> on 4-5 (NO) (Resistive load)	400 V AC, 2 A
Max. terminal load (AC-15) <sup>1)</sup> on 4-5 (NO) (Inductive load @ cosφ 0.4)	240 V AC, 0.2 A
Max. terminal load (DC-1) <sup>1)</sup> on 4-5 (NO) (Resistive load)	80 V DC, 2 A
Max. terminal load (DC-13) <sup>1)</sup> on 4-5 (NO) (Inductive load)	24 V DC, 0.1 A
Max. terminal load (AC-1) <sup>1)</sup> on 4-6 (NC) (Resistive load)	240 V AC, 2 A
Max. terminal load (AC-15) <sup>1)</sup> on 4-6 (NC) (Inductive load @ cosφ 0.4)	240 V AC, 0.2 A
Max. terminal load (DC-1) <sup>1)</sup> on 4-6 (NC) (Resistive load)	50 V DC, 2 A
Max. terminal load (DC-13) <sup>1)</sup> on 4-6 (NC) (Inductive load)	24 V DC, 0.1 A
Min. terminal load on 1-3 (NC), 1-2 (NO), 4-6 (NC), 4-5 (NO)	24 V DC 10 mA, 24 V AC 20 mA
Environment according to EN 60664-1	over-voltage category III/pollution degree 2

1) IEC 60947 part 4 and 5

The relay contacts are galvanically isolated from the rest of the circuit by reinforced isolation (PELV).

**Cable lengths and cross sections**

Max. motor cable length, screened/armoured	150 m
Max. motor cable length, unscreened/unarmoured	300 m
Maximum cross section to control terminals, flexible/ rigid wire without cable end sleeves	1.5 mm <sup>2</sup> /16 AWG
Maximum cross section to control terminals, flexible wire with cable end sleeves	1 mm <sup>2</sup> /18 AWG
Maximum cross section to control terminals, flexible wire with cable end sleeves with collar	0.5 mm <sup>2</sup> /20 AWG
Minimum cross section to control terminals	0.25 mm <sup>2</sup> /24 AWG

**Control card performance**

Scan interval	1 ms
Control characteristics	
Resolution of output frequency at 0-1000 Hz	± 0.003 Hz
Repeat accuracy of <i>Precise start/stop</i> (terminals 18, 19)	± 0.1 ms
System response time (terminals 18, 19, 27, 29, 32, 33)	≤ 2 ms
Speed control range (open loop)	1:100 of synchronous speed
Speed control range (closed loop)	1:1000 of synchronous speed
Speed accuracy (open loop)	30-4000 rpm: error ±8 rpm
Speed accuracy (closed loop), depending on resolution of feedback device	0-6000 rpm: error ±0.15 rpm
Torque control accuracy (speed feedback)	max error ±5% of rated torque

All control characteristics are based on a 4-pole asynchronous motor

**Surroundings**

Enclosure	IP21/Type 1, IP54/Type 12
Vibration test	0.7 g
Max. relative humidity	5%-95%(IEC 721-3-3; Class 3K3 (non-condensing) during operation
Aggressive environment (IEC 60068-2-43)	class H25
Ambient temperature (with SFAVM switching mode)	
- with derating	Max. 55° C <sup>1)</sup>
- at full continuous drive output current	Max. 45° C <sup>1)</sup>
1) For more information on derating, see special conditions in the VLT AutomationDrive Design Guide, MG33BXY	
Minimum ambient temperature during full-scale operation	0° C
Minimum ambient temperature at reduced performance	- 10° C
Temperature during storage/transport	-25 - +65/70° C
Maximum altitude above sea level without derating	1000 m

*Derating for high altitude, see special conditions in the VLT AutomationDrive Design Guide, MG33BXY*

EMC standards, Emission	EN 61800-3, EN 61000-6-3/4, EN 55011
EMC standards, Immunity	EN 61800-3, EN 61000-6-1/2, EN 61000-4-2, EN 61000-4-3, EN 61000-4-4, EN 61000-4-5, EN 61000-4-6

*See section on special conditions in the VLT AutomationDrive Design Guide, MG33BXY.*

**Protection and Features**

- Electronic thermal motor protection against overload.
- Temperature monitoring of the heatsink ensures that the frequency converter trips if the temperature reaches a predefined level. An overload temperature cannot be reset until the temperature of the heatsink is below the values stated in the tables on the following pages (Guideline - these temperatures may vary for different power sizes, frame sizes, enclosure ratings etc.).
- The frequency converter is protected against short-circuits on motor terminals U, V, W.
- If a mains phase is missing, the frequency converter trips or issues a warning (depending on the load).
- Monitoring of the intermediate circuit voltage ensures that the frequency converter trips if the intermediate circuit voltage is too low or too high.
- The frequency converter constantly checks for critical levels of internal temperature, load current, high voltage on the intermediate circuit and low motor speeds. As a response to a critical level, the frequency converter can adjust the switching frequency and/ or change the switching pattern in order to ensure the performance of the frequency converter.

<b>Mains Supply 6x380-500 V AC, 12-Pulse</b>								
<b>FC 302</b>	<b>P250</b>		<b>P315</b>		<b>P355</b>		<b>P400</b>	
High/ Normal Load*	HO	NO	HO	NO	HO	NO	HO	NO
Typical Shaft output at 400 V [kW]	250	315	315	355	355	400	400	450
Typical Shaft output at 460 V [HP]	350	450	450	500	500	600	550	600
Typical Shaft output at 500 V [kW]	315	355	355	400	400	500	500	530
Enclosure IP21	F8/F9		F8/F9		F8/F9		F8/F9	
Enclosure IP54	F8/F9		F8/F9		F8/F9		F8/F9	
<b>Output current</b>								
Continuous (at 400 V) [A]	480	600	600	658	658	745	695	800
Intermittent (60 s overload) (at 400 V) [A]	720	660	900	724	987	820	1043	880
Continuous (at 460/500 V) [A]	443	540	540	590	590	678	678	730
Intermittent (60 s overload) (at 460/500 V) [A]	665	594	810	649	885	746	1017	803
Continuous KVA (at 400 V) [KVA]	333	416	416	456	456	516	482	554
Continuous KVA (at 460 V) [KVA]	353	430	430	470	470	540	540	582
Continuous KVA (at 500 V) [KVA]	384	468	468	511	511	587	587	632
<b>Max. input current</b>								
Continuous (at 400 V) [A]	472	590	590	647	647	733	684	787
Continuous (at 460/500 V) [A]	436	531	531	580	580	667	667	718
Max. cable size, mains [mm <sup>2</sup> (AWG <sup>2</sup> )]	4x90 (3/0)		4x90 (3/0)		4x240 (500 mcm)		4x240 (500 mcm)	
Max. cable size, motor [mm <sup>2</sup> (AWG <sup>2</sup> )]	4x240 (4x500 mcm)		4x240 (4x500 mcm)		4x240 (4x500 mcm)		4x240 (4x500 mcm)	
Max. cable size, brake [mm <sup>2</sup> (AWG <sup>2</sup> )]	2 x 185 (2 x 350 mcm)		2 x 185 (2 x 350 mcm)		2 x 185 (2 x 350 mcm)		2 x 185 (2 x 350 mcm)	
Max. external mains fuses [A] <sup>1</sup>	700							
Estimated power loss at 400 V [W] <sup>4)</sup>	5164	6790	6960	7701	7691	8879	8178	9670
Estimated power loss at 460 V [W]	4822	6082	6345	6953	6944	8089	8085	8803
Weight, enclosure IP21, IP54 [kg]	440/656							
Efficiency <sup>4)</sup>	0.98							
Output frequency	0 - 600 Hz							
Heatsink overtemp. trip	95° C							
Power card ambient trip	75° C							

\* High overload = 160% torque during 60 s, Normal overload = 110% torque during 60 s

<b>Mains Supply 6x380-500 V AC, 12-Pulse</b>												
<b>FC 302</b>	<b>P450</b>		<b>P500</b>		<b>P560</b>		<b>P630</b>		<b>P710</b>		<b>P800</b>	
High/ Normal Load *	HO	NO	HO	NO	HO	NO	HO	NO	HO	NO	HO	NO
Typical Shaft output at 400 V [kW]	450	500	500	560	560	630	630	710	710	800	800	1000
Typical Shaft output at 460 V [HP]	600	650	650	750	750	900	900	1000	1000	1200	1200	1350
Typical Shaft output at 500 V [kW]	530	560	560	630	630	710	710	800	800	1000	1000	1100
Enclosure IP21, 54 without/ with options cabinet	F10/F11		F10/F11		F10/F11		F10/F11		F12/F13		F12/F13	
<b>Output current</b>												
Continuous (at 400 V) [A]	800	880	880	990	990	1120	1120	1260	1260	1460	1460	1720
Intermittent (60 s overload) (at 400 V) [A]	1200	968	1320	1089	1485	1232	1680	1386	1890	1606	2190	1892
Continuous (at 460/500 V) [A]	730	780	780	890	890	1050	1050	1160	1160	1380	1380	1530
Intermittent (60 s overload) (at 460/500 V) [A]	1095	858	1170	979	1335	1155	1575	1276	1740	1518	2070	1683
Continuous KVA (at 400 V) [KVA]	554	610	610	686	686	776	776	873	873	1012	1012	1192
Continuous KVA (at 460 V) [KVA]	582	621	621	709	709	837	837	924	924	1100	1100	1219
Continuous KVA (at 500 V) [KVA]	632	675	675	771	771	909	909	1005	1005	1195	1195	1325
<b>Max. input current</b>												
Continuous (at 400 V) [A]	779	857	857	964	964	1090	1090	1227	1227	1422	1422	1675
Continuous (at 460/ 500 V) [A]	711	759	759	867	867	1022	1022	1129	1129	1344	1344	1490
Max. cable size, motor [mm <sup>2</sup> (AWG <sup>2</sup> )]	8x150 (8x300 mcm)						12x150 (12x300 mcm)					
Max. cable size, mains [mm <sup>2</sup> (AWG <sup>2</sup> )]	6x120 (6x250 mcm)						6x120 (6x250 mcm)					
Max. cable size, brake [mm <sup>2</sup> (AWG <sup>2</sup> )]	4x185 (4x350 mcm)						6x185 (6x350 mcm)					
Max. external mains fuses [A] <sup>1</sup>	900						1500					
Estimated power loss at 400 V [W] <sup>4)</sup>	9492	10647	10631	12338	11263	13201	13172	15436	14967	18084	16392	20358
Estimated power loss at 460 V [W]	8730	9414	9398	11006	10063	12353	12332	14041	13819	17137	15577	17752
F9/F11/F13 max. added losses A1 RFI, CB or Disconnect, & contactor F9/F11/F13	893	963	951	1054	978	1093	1092	1230	2067	2280	2236	2541
Max. panel options losses	400											
Weight, enclosure IP21, IP54 [kg]	1004/ 1299		1004/ 1299		1004/ 1299		1004/ 1299		1246/ 1541		1246/ 1541	
Weight Rectifier Module [kg]	102		102		102		102		136		136	
Weight Inverter Module [kg]	102		102		102		136		102		102	
Efficiency <sup>4)</sup>	0.98											
Output frequency	0-600 Hz											
Heatsink overtemp. trip	95° C											
Power card ambient trip	75° C											
* High overload = 160% torque during 60 s, Normal overload = 110% torque during 60 s												

Mains Supply 6x525-690 V AC, 12-Pulse								
FC 302	P355		P400		P500		P560	
High/ Normal Load	HO	NO	HO	NO	HO	NO	HO	NO
Typical Shaft output at 550 V [kW]	315	355	315	400	400	450	450	500
Typical Shaft output at 575 V [HP]	400	450	400	500	500	600	600	650
Typical Shaft output at 690 V [kW]	355	450	400	500	500	560	560	630
Enclosure IP21	F8/F9		F8/F9		F8/F9		F8/F9	
Enclosure IP54	F8/F9		F8/F9		F8/F9		F8/F9	
<b>Output current</b>								
Continuous (at 550 V) [A]	395	470	429	523	523	596	596	630
Intermittent (60 s overload) (at 550 V) [A]	593	517	644	575	785	656	894	693
Continuous (at 575/690 V) [A]	380	450	410	500	500	570	570	630
Intermittent (60 s overload) (at 575/690 V) [A]	570	495	615	550	750	627	855	693
Continuous KVA (at 550 V) [KVA]	376	448	409	498	498	568	568	600
Continuous KVA (at 575 V) [KVA]	378	448	408	498	498	568	568	627
Continuous KVA (at 690 V) [KVA]	454	538	490	598	598	681	681	753
<b>Max. input current</b>								
Continuous (at 550 V) [A]	381	453	413	504	504	574	574	607
Continuous (at 575 V) [A]	366	434	395	482	482	549	549	607
Continuous (at 690 V) [A]	366	434	395	482	482	549	549	607
Max. cable size, mains [mm <sup>2</sup> (AWG)]	4x85 (3/0)							
Max. cable size, motor [mm <sup>2</sup> (AWG)]	4x250 (500 mcm)							
Max. cable size, brake [mm <sup>2</sup> (AWG)]	2x185 (2x350 mcm)		2x185 (2x350 mcm)		2x185 (2x350 mcm)		2x185 (2x350 mcm)	
Max. external mains fuses [A] <sup>1</sup>	630							
Estimated power loss at 600 V [W] <sup>4)</sup>	5107	6132	5538	6903	7336	8343	8331	9244
Estimated power loss at 690 V [W] <sup>4)</sup>	5383	6449	5818	7249	7671	8727	8715	9673
Weight, enclosure IP21, IP54 [kg]	440/656							
Efficiency <sup>4)</sup>	0.98							
Output frequency	0 - 500 Hz							
Heatsink overtemp. trip	85° C							
Power card ambient trip	75° C							

\* High overload = 160% torque during 60 s, Normal overload = 110% torque during 60 s

<b>Mains Supply 6x525-690 V AC, 12-Pulse</b>						
<b>FC 302</b>	<b>P630</b>		<b>P710</b>		<b>P800</b>	
High/ Normal Load	HO	NO	HO	NO	HO	NO
Typical Shaft output at 550 V [kW]	500	560	560	670	670	750
Typical Shaft output at 575 V [HP]	650	750	750	950	950	1050
Typical Shaft output at 690 V [kW]	630	710	710	800	800	900
Enclosure IP21, IP54 without/ with options cabinet	F10/F11		F10/F11		F10/F11	
<b>Output current</b>						
Continuous (at 550 V) [A]	659	763	763	889	889	988
Intermittent (60 s overload) (at 550 V) [A]	989	839	1145	978	1334	1087
Continuous (at 575/690 V) [A]	630	730	730	850	850	945
Intermittent (60 s overload) (at 575/690 V) [A]	945	803	1095	935	1275	1040
Continuous KVA (at 550 V) [KVA]	628	727	727	847	847	941
Continuous KVA (at 575 V) [KVA]	627	727	727	847	847	941
Continuous KVA (at 690 V) [KVA]	753	872	872	1016	1016	1129
<b>Max. input current</b>						
Continuous (at 550 V) [A]	642	743	743	866	866	962
Continuous (at 575 V) [A]	613	711	711	828	828	920
Continuous (at 690 V) [A]	613	711	711	828	828	920
Max. cable size, motor [mm <sup>2</sup> (AWG <sup>2</sup> )]	8x150 (8x300 mcm)					
Max. cable size, mains [mm <sup>2</sup> (AWG <sup>2</sup> )]	6x120 (6x250 mcm)					
Max. cable size, brake [mm <sup>2</sup> (AWG <sup>2</sup> )]	4x185 (4x350 mcm)					
Max. external mains fuses [A] <sup>1</sup>	900					
Estimated power loss at 600 V [W] <sup>4</sup>	9201	10771	10416	12272	12260	13835
Estimated power loss at 690 V [W] <sup>4</sup>	9674	11315	10965	12903	12890	14533
F3/F4 Max added losses CB or Disconnect & Contactor	342	427	419	532	519	615
Max panel options losses	400					
Weight, enclosure IP21, IP54 [kg]	1004/1299		1004/1299		1004/1299	
Weight, Rectifier Module [kg]	102		102		102	
Weight, Inverter Module [kg]	102		102		136	
Efficiency <sup>4</sup>	0.98					
Output frequency	0-500 Hz					
Heatsink overtemp. trip	85° C					
Power card ambient trip	75° C					

\* High overload = 160% torque during 60 s, Normal overload = 110% torque during 60 s

Mains Supply 6x525-690 V AC, 12-Pulse								
FC 302	P900		P1M0		P1M2		P1M4	
High/ Normal Load*	HO	NO	HO	NO	HO	NO	HO	NO
Typical Shaft output at 550 V [kW]	750	850	850	1000	1000	1100	1100	1250
Typical Shaft output at 575 V [HP]	1050	1150	1150	1350	1350	1550	1550	1700
Typical Shaft output at 690 V [kW]	900	1000	1000	1200	1200	1400	1400	1600
Enclosure IP21, IP54 without/ with options cabinet	F12/F13		F12/F13		F12/F13		F14	
<b>Output current</b>								
Continuous (at 550 V) [A]	988	1108	1108	1317	1317	1479	1479	1652
Intermittent (60 s overload) (at 550 V) [A]	1482	1219	1662	1449	1976	1627	2218.5	1817.2
Continuous (at 575/690 V) [A]	945	1060	1060	1260	1260	1415	1415	1580
Intermittent (60 s overload) (at 575/690 V) [A]	1418	1166	1590	1386	1890	1557	2122	1738
Continuous KVA (at 550 V) [KVA]	941	1056	1056	1255	1255	1409	1409	1574
Continuous KVA (at 575 V) [KVA]	941	1056	1056	1255	1255	1409	1409	1574
Continuous KVA (at 690 V) [KVA]	1129	1267	1267	1506	1506	1691	1348	1505
<b>Max. input current</b>								
Continuous (at 550 V) [A]	962	1079	1079	1282	1282	1440	1440	1608
Continuous (at 575 V) [A]	920	1032	1032	1227	1227	1378	1378	1538
Continuous (at 690 V) [A]	920	1032	1032	1227	1227	1378	1378	1538
Max. cable size, motor [mm <sup>2</sup> (AWG <sup>2)</sup> ]	12x150 (12x300 mcm)							
Max. cable size, mains F12 [mm <sup>2</sup> (AWG <sup>2)</sup> ]	8x240 (8x500 mcm)							
Max. cable size, mains F13 [mm <sup>2</sup> (AWG <sup>2)</sup> ]	8x400 (8x900 mcm)							
Max. cable size, brake [mm <sup>2</sup> (AWG <sup>2)</sup> ]	6x185 (6x350 mcm)							
Max. external mains fuses [A] <sup>1</sup>	1600		2000		2500			
Estimated power loss at 600 V [W] <sup>4)</sup>	13755	15592	15107	18281	18181	20825	18843	21464
Estimated power loss at 690 V [W] <sup>4)</sup>	14457	16375	15899	19207	19105	21857	19191	21831
F3/F4 Max added losses CB or Disconnect & Contactor	556	665	634	863	861	1044	1016	1267
Max panel options losses	400							
Weight, enclosure IP21, IP54 [kg]	1246/ 1541		1246/ 1541		1280/1575		3077/3372	
Weight, Rectifier Module [kg]	136							
Weight, Inverter Module [kg]	102				136			
Efficiency <sup>4)</sup>	0.98							
Output frequency	0-500 Hz							
Heatsink overtemp. trip	85° C							
Power card ambient trip	75° C							

\* High overload = 160% torque during 60 s, Normal overload = 110% torque during 60 s

1) For type of fuse see section *Fuses*.

2) American Wire Gauge.

3) Measured using 5 m screened motor cables at rated load and rated frequency.

4) The typical power loss is at nominal load conditions and expected to be within ±15% (tolerance relates to variety in voltage and cable conditions).

Values are based on a typical motor efficiency. Motors with lower efficiency will also add to the power loss in the frequency converter and opposite.

If the switching frequency is increased compared to the default setting, the power losses may rise significantly.

LCP and typical control card power consumptions are included. Further options and customer load may add up to 30 W to the losses. (Though typical only 4 W extra for a fully loaded control card, or options for slot A or slot B, each).

Although measurements are made with state of the art equipment, some measurement inaccuracy must be allowed for (±5%).

## 6 Warnings and Alarms

### 6.1 Warning and Alarm Definitions

The warning/alarm information below defines each warning/alarm condition, provides the probable cause for the condition, and details a remedy or troubleshooting procedure.

#### WARNING 1, 10 Volts low

The control card voltage is below 10 V from terminal 50. Remove some of the load from terminal 50, as the 10 V supply is overloaded. Max. 15 mA or minimum 590 Ω.

This condition can be caused by a short in a connected potentiometer or improper wiring of the potentiometer.

#### Troubleshooting

Remove the wiring from terminal 50. If the warning clears, the problem is with the customer wiring. If the warning does not clear, replace the control card.

#### WARNING/ALARM 2, Live zero error

This warning or alarm only appears if programmed by the user in *6-01 Live Zero Timeout Function*. The signal on one of the analog inputs is less than 50% of the minimum value programmed for that input. Broken wiring or faulty device sending the signal can cause this condition.

#### Troubleshooting

Check connections on all the analog input terminals. Control card terminals 53 and 54 for signals, terminal 55 common. MCB 101 terminals 11 and 12 for signals, terminal 10 common. MCB 109 terminals 1, 3, 5 for signals, terminals 2, 4, 6 common).

Check that the frequency converter programming and switch settings match the analog signal type.

Perform Input Terminal Signal Test.

#### WARNING/ALARM 3, No motor

No motor has been connected to the output of the frequency converter.

#### WARNING/ALARM 4, Mains phase loss

A phase is missing on the supply side, or the mains voltage imbalance is too high. This message also appears for a fault in the input rectifier on the frequency converter. Options are programmed at *14-12 Function at Mains Imbalance*.

#### Troubleshooting

Check the supply voltage and supply currents to the frequency converter.

#### WARNING 5, DC link voltage high

The intermediate circuit voltage (DC) is higher than the high voltage warning limit. The limit is dependent on the frequency converter voltage rating. The unit is still active.

#### WARNING 6, DC link voltage low

The intermediate circuit voltage (DC) is lower than the low voltage warning limit. The limit is dependent on the frequency converter voltage rating. The unit is still active.

#### WARNING/ALARM 7, DC overvoltage

If the intermediate circuit voltage exceeds the limit, the frequency converter trips after a time.

#### Troubleshooting

Connect a brake resistor

Extend the ramp time

Change the ramp type

Activate the functions in *2-10 Brake Function*

Increase *14-26 Trip Delay at Inverter Fault*

#### WARNING/ALARM 8, DC under voltage

If the intermediate circuit voltage (DC link) drops below the under voltage limit, the frequency converter checks if a 24 V DC backup supply is connected. If no 24 V DC backup supply is connected, the frequency converter trips after a fixed time delay. The time delay varies with unit size.

#### Troubleshooting

Check that the supply voltage matches the frequency converter voltage.

Perform input voltage test.

Perform soft charge circuit test.

#### WARNING/ALARM 9, Inverter overload

The frequency converter is about to cut out because of an overload (too high current for too long). The counter for electronic, thermal inverter protection gives a warning at 98% and trips at 100%, while giving an alarm. The frequency converter *cannot* be reset until the counter is below 90%.

The fault is that the frequency converter is overloaded by more than 100% for too long.

#### Troubleshooting

Compare the output current shown on the LCP with the frequency converter rated current.

Compare the output current shown on the LCP with measured motor current.

Display the Thermal Drive Load on the LCP and monitor the value. When running above the frequency converter continuous current rating, the counter should increase. When running below the frequency converter continuous current rating, the counter should decrease.



See the derating section in the *VLT® Automation Drive FC 300 Design Guide, MG33BXYY* for more details if a high switching frequency is required.

#### **WARNING/ALARM 10, Motor overload temperature**

According to the electronic thermal protection (ETR), the motor is too hot. Select whether the frequency converter gives a warning or an alarm when the counter reaches 100% in *1-90 Motor Thermal Protection*. The fault occurs when the motor is overloaded by more than 100% for too long.

#### **Troubleshooting**

Check for motor overheating.

Check if the motor is mechanically overloaded

Check that the motor current set in *1-24 Motor Current* is correct.

Ensure that Motor data in parameters 1-20 through 1-25 are set correctly.

If an external fan is in use, check in *1-91 Motor External Fan* that it is selected.

Running AMA in *1-29 Automatic Motor Adaptation (AMA)* tunes the frequency converter to the motor more accurately and reduces thermal loading.

#### **WARNING/ALARM 11, Motor thermistor over temp**

The thermistor might be disconnected. Select whether the frequency converter gives a warning or an alarm in *1-90 Motor Thermal Protection*.

#### **Troubleshooting**

Check for motor overheating.

Check if the motor is mechanically overloaded.

Check that the thermistor is connected correctly between either terminal 53 or 54 (analog voltage input) and terminal 50 (+10 V supply) and that the terminal switch for 53 or 54 is set for voltage. Check *1-93 Thermistor Source* selects terminal 53 or 54.

When using digital inputs 18 or 19, check that the thermistor is connected correctly between either terminal 18 or 19 (digital input PNP only) and terminal 50.

If a KTY sensor is used, check for correct connection between terminals 54 and 55

If using a thermal switch or thermistor, check that the programming if *1-93 Thermistor Resource* matches sensor wiring.

If using a KTY sensor, check the programming of *1-95 KTY Sensor Type*, *1-96 KTY Thermistor Resource*, and *1-97 KTY Threshold level* match sensor wiring.

#### **WARNING/ALARM 12, Torque limit**

The torque has exceeded the value in *4-16 Torque Limit Motor Mode* or the value in *4-17 Torque Limit Generator Mode*. *14-25 Trip Delay at Torque Limit* can change this from a warning only condition to a warning followed by an alarm.

#### **Troubleshooting**

If the motor torque limit is exceeded during ramp up, extend the ramp up time.

If the generator torque limit is exceeded during ramp down, extend the ramp down time.

If torque limit occurs while running, possibly increase the torque limit. Be sure the system can operate safely at a higher torque.

Check the application for excessive current draw on the motor.

#### **WARNING/ALARM 13, Over current**

The inverter peak current limit (approximately 200% of the rated current) is exceeded. The warning lasts about 1.5 secs., then the frequency converter trips and issues an alarm. This fault may be caused by shock loading or fast acceleration with high inertia loads. If extended mechanical brake control is selected, trip can be reset externally.

#### **Troubleshooting**

Remove power and check if the motor shaft can be turned.

Check that the motor size matches the frequency converter.

Check parameters 1-20 through 1-25. for correct motor data.

#### **ALARM 14, Earth (ground) fault**

There is current from the output phases to earth, either in the cable between the frequency converter and the motor or in the motor itself.

#### **Troubleshooting:**

Remove power to the frequency converter and repair the earth fault.

Check for earth faults in the motor by measuring the resistance to ground of the motor leads and the motor with a megohmmeter.

Perform current sensor test.

#### **ALARM 15, Hardware mismatch**

A fitted option is not operational with the present control board hardware or software.

Record the value of the following parameters and contact your Danfoss supplier:

*15-40 FC Type*

*15-41 Power Section*

*15-42 Voltage*

- 15-43 Software Version
- 15-45 Actual Typecode String
- 15-49 SW ID Control Card
- 15-50 SW ID Power Card
- 15-60 Option Mounted
- 15-61 Option SW Version (for each option slot)

**ALARM 16, Short circuit**

There is short-circuiting in the motor or motor wiring.

Remove power to the frequency converter and repair the short circuit.

**WARNING/ALARM 17, Control word timeout**

There is no communication to the frequency converter. The warning will only be active when *8-04 Control Word Timeout Function* is NOT set to OFF.

If *8-04 Control Word Timeout Function* is set to *Stop* and *Trip*, a warning appears and the frequency converter ramps down until it trips then displays an alarm.

**Troubleshooting:**

- Check connections on the serial communication cable.
- Increase *8-03 Control Word Timeout Time*
- Check the operation of the communication equipment.
- Verify a proper installation based on EMC requirements.

**WARNING/ALARM 22, Hoist mechanical brake**

Report value shows what kind it is.

0 = The torque ref. was not reached before timeout.

1 = There was no brake feedback before timeout.

**WARNING 23, Internal fan fault**

The fan warning function is an extra protective function that checks if the fan is running/mounted. The fan warning can be disabled in *14-53 Fan Monitor* ([0] Disabled).

For the D, E, and F Frame filters, the regulated voltage to the fans is monitored.

**Troubleshooting**

- Check fan resistance.
- Check soft charge fuses.

**WARNING 24, External fan fault**

The fan warning function is an extra protective function that checks if the fan is running/mounted. The fan warning can be disabled in *14-53 Fan Monitor* ([0] Disabled).

**Troubleshooting**

- Check fan resistance.
- Check soft charge fuses.

**WARNING 25, Brake resistor short circuit**

The brake resistor is monitored during operation. If a short circuit occurs, the brake function is disabled and the warning appears. The frequency converter is still operational but without the brake function. Remove power

to the frequency converter and replace the brake resistor (see *2-15 Brake Check*).

**WARNING/ALARM 26, Brake resistor power limit**

The power transmitted to the brake resistor is calculated as a mean value over the last 120 s of run time. The calculation is based on the intermediate circuit voltage and the brake resistance value set in *2-16 AC brake Max. Current*. The warning is active when the dissipated braking is higher than 90% of the brake resistance power. If *Trip* [2] is selected in *2-13 Brake Power Monitoring*, the frequency converter will trip when the dissipated braking power reaches 100%.



**There is a risk of substantial power being transmitted to the brake resistor if the brake transistor is short-circuited.**

**WARNING/ALARM 27, Brake chopper fault**

The brake transistor is monitored during operation and if a short circuit occurs, the brake function is disabled and a warning is issued. The frequency converter is still operational but, since the brake transistor has short-circuited, substantial power is transmitted to the brake resistor, even if it is inactive.

Remove power to the frequency converter and remove the brake resistor.

This alarm/warning could also occur should the brake resistor overheat. Terminals 104 and 106 are available as brake resistors Klixon ininputs, see section Brake Resistor Temperature Switch.

**WARNING/ALARM 28, Brake check failed**

The brake resistor is not connected or not working. Check *2-15 Brake Check*.

**ALARM 29, Heatsink temp**

The maximum temperature of the heatsink has been exceeded. The temperature fault will not reset until the temperature falls below a defined heatsink temperature. The trip and reset points are different based on the frequency converter power size.

**Troubleshooting**

Check for the following conditions.

- Ambient temperature too high.
- Motor cable too long.
- Incorrect airflow clearance above and below the frequency converter
- Blocked airflow around the frequency converter.
- Damaged heatsink fan.
- Dirty heatsink.

For the D, E, and F Frame sizes, this alarm is based on the temperature measured by the heatsink sensor mounted inside the IGBT modules. For the F Frame sizes, this alarm can also be caused by the thermal sensor in the Rectifier module.

**Troubleshooting**

Check fan resistance.

Check soft charge fuses.

IGBT thermal sensor.

**ALARM 30, Motor phase U missing**

Motor phase U between the frequency converter and the motor is missing.

Remove power from the frequency converter and check motor phase U.

**ALARM 31, Motor phase V missing**

Motor phase V between the frequency converter and the motor is missing.

Remove power from the frequency converter and check motor phase V.

**ALARM 32, Motor phase W missing**

Motor phase W between the frequency converter and the motor is missing.

Remove power from the frequency converter and check motor phase W.

**ALARM 33, Inrush fault**

Too many power-ups have occurred within a short time period. Let the unit cool to operating temperature.

**WARNING/ALARM 34, communication fault**

The fieldbus on the communication option card is not working.

**WARNING/ALARM 36, Mains failure**

This warning/alarm is only active if the supply voltage to the frequency converter is lost and *14-10 Mains Failure* is NOT set to [0] *No Function*. Check the fuses to the frequency converter and mains power supply to the unit.

**ALARM 38, Internal fault**

When an internal fault occurs, a code number defined in the table below is displayed.

**Troubleshooting**

Cycle power

Check that the option is properly installed

Check for loose or missing wiring

It may be necessary to contact your Danfoss supplier or service department. Note the code number for further troubleshooting directions.

No.	Text
0	Serial port cannot be initialised. Contact your Danfoss supplier or Danfoss Service Department.
256-258	Power EEPROM data is defective or too old
512	Control board EEPROM data is defective or too old.
513	Communication time out reading EEPROM data
514	Communication time out reading EEPROM data
515	Application oriented control cannot recognize the EEPROM data.

No.	Text
516	Cannot write to the EEPROM because a write command is on progress.
517	Write command is under time out
518	Failure in the EEPROM
519	Missing or invalid barcode data in EEPROM
783	Parameter value outside of min/max limits
1024-1279	A centelegram that has to be sent couldn't be sent.
1281	Digital signal processor flash timeout
1282	Power micro software version mismatch
1283	Power EEPROM data version mismatch
1284	Cannot read digital signal processor software version
1299	Option SW in slot A is too old
1300	Option SW in slot B is too old
1301	Option SW in slot C0 is too old
1302	Option SW in slot C1 is too old
1315	Option SW in slot A is not supported (not allowed)
1316	Option SW in slot B is not supported (not allowed)
1317	Option SW in slot C0 is not supported (not allowed)
1318	Option SW in slot C1 is not supported (not allowed)
1379	Option A did not respond when calculating platform version
1380	Option B did not respond when calculating platform version
1381	Option C0 did not respond when calculating platform version.
1382	Option C1 did not respond when calculating platform version.
1536	An exception in the application oriented control is registered. Debug information written in LCP
1792	DSP watchdog is active. Debugging of power part data, motor oriented control data not transferred correctly.
2049	Power data restarted
2064-2072	H081x: option in slot x has restarted
2080-2088	H082x: option in slot x has issued a powerup-wait
2096-2104	H983x: option in slot x has issued a legal powerup-wait
2304	Could not read any data from power EEPROM
2305	Missing SW version from power unit
2314	Missing power unit data from power unit
2315	Missing SW version from power unit
2316	Missint lo_statepage from power unit
2324	Power card configuration is determined to be incorrect at power up
2325	A power card has stopped communicating while main power is applied
2326	Power card configuration is determined to be incorrect after the delay for power cards to register.

No.	Text
2327	Too many power card locations have been registered as present.
2330	Power size information between the power cards does not match.
2561	No communication from DSP to ATACD
2562	No communication from ATACD to DSP (state running)
2816	Stack overflow control board module
2817	Scheduler slow tasks
2818	Fast tasks
2819	Parameter thread
2820	LCP stack overflow
2821	Serial port overflow
2822	USB port overflow
2836	cflistMempool too small
3072-5122	Parameter value is outside its limits
5123	Option in slot A: Hardware incompatible with control board hardware
5124	Option in slot B: Hardware incompatible with Control board hardware.
5125	Option in slot C0: Hardware incompatible with control board hardware.
5126	Option in slot C1: Hardware incompatible with control board hardware.
5376-6231	Out of memory

**ALARM 39, Heatsink sensor**

No feedback from the heatsink temperature sensor.

The signal from the IGBT thermal sensor is not available on the power card. The problem could be on the power card, on the gate drive card, or the ribbon cable between the power card and gate drive card.

**WARNING 40, Overload of digital output terminal 27**

Check the load connected to terminal 27 or remove short-circuit connection. Check *5-00 Digital I/O Mode* and *5-01 Terminal 27 Mode*.

**WARNING 41, Overload of digital output terminal 29**

Check the load connected to terminal 29 or remove short-circuit connection. Check *5-00 Digital I/O Mode* and *5-02 Terminal 29 Mode*.

**WARNING 42, Overload of digital output on X30/6 or overload of digital output on X30/7**

For X30/6, check the load connected to X30/6 or remove the short-circuit connection. Check *5-32 Term X30/6 Digi Out (MCB 101)*.

For X30/7, check the load connected to X30/7 or remove the short-circuit connection. Check *5-33 Term X30/7 Digi Out (MCB 101)*.

**ALARM 46, Power card supply**

The supply on the power card is out of range.

There are three power supplies generated by the switch mode power supply (SMPS) on the power card: 24 V, 5 V,  $\pm 18$  V. When powered with 24 V DC with the MCB 107

option, only the 24 V and 5 V supplies are monitored. When powered with three phase mains voltage, all three supplies are monitored.

**WARNING 47, 24V supply low**

The 24 V DC is measured on the control card. The external 24 V DC backup power supply may be overloaded, otherwise contact your Danfoss supplier.

**WARNING 48, 1.8V supply low**

The 1.8 V DC supply used on the control card is outside of allowable limits. The power supply is measured on the control card. Check for a defective control card. If an option card is present, check for an overvoltage condition.

**WARNING 49, Speed limit**

When the speed is not within the specified range in *4-11 Motor Speed Low Limit [RPM]* and *4-13 Motor Speed High Limit [RPM]*, the frequency converter shows a warning. When the speed is below the specified limit in *1-86 Trip Speed Low [RPM]* (except when starting or stopping) the frequency converter will trip.

**ALARM 50, AMA calibration failed**

Contact your Danfoss supplier or Danfoss Service Department.

**ALARM 51, AMA check  $U_{nom}$  and  $I_{nom}$** 

The settings for motor voltage, motor current, and motor power are wrong. Check the settings in parameters 1-20 to 1-25.

**ALARM 52, AMA low  $I_{nom}$** 

The motor current is too low. Check the settings.

**ALARM 53, AMA motor too big**

The motor is too big for the AMA to operate.

**ALARM 54, AMA motor too small**

The motor is too small for the AMA to operate.

**ALARM 55, AMA Parameter out of range**

The parameter values of the motor are outside of the acceptable range. AMA will not run.

**56 ALARM, AMA interrupted by user**

The user has interrupted the AMA.

**ALARM 57, AMA internal fault**

Try to restart AMA again a number of times, until the AMA is carried out. Note that repeated runs may heat the motor to a level where the resistance  $R_s$  and  $R_r$  are increased. In most cases, however, this is not critical.

**ALARM 58, AMA internal fault**

Contact your Danfoss supplier.

**WARNING 59, Current limit**

The current is higher than the value in *4-18 Current Limit*. Ensure that Motor data in parameters 1-20 through 1-25 are set correctly. Possibly increase the current limit. Be sure that the system can operate safely at a higher limit.

**WARNING 60, External interlock**

External interlock has been activated. To resume normal operation, apply 24 V DC to the terminal programmed for external interlock and reset the frequency converter (via serial communication, digital I/O, or by pressing [Reset]).

**WARNING/ALARM 61, Tracking error**

An error between calculated motor speed and speed measurement from feedback device. The function Warning/Alarm/Disable is set in *4-30 Motor Feedback Loss Function*. Accepted error setting in *4-31 Motor Feedback Speed Error* and the allowed time the error occur setting in *4-32 Motor Feedback Loss Timeout*. During a commissioning procedure the function may be effective.

**WARNING 62, Output frequency at maximum limit**

The output frequency is higher than the value set in *4-19 Max Output Frequency*.

**ALARM 64, Voltage Limit**

The load and speed combination demands a motor voltage higher than the actual DC link voltage.

**WARNING/ALARM 65, Control card over temperature**

The cutout temperature of the control card is 80° C.

**Troubleshooting**

- Check that the ambient operating temperature is within limits
- Check for clogged filters
- Check fan operation
- Check the control card

**WARNING 66, Heatsink temperature low**

The frequency converter is too cold to operate. This warning is based on the temperature sensor in the IGBT module.

Increase the ambient temperature of the unit. Also, a trickle amount of current can be supplied to the frequency converter whenever the motor is stopped by setting *2-00 DC Hold/Preheat Current* at 5% and *1-80 Function at Stop*

**Troubleshooting**

The heatsink temperature measured as 0° C could indicate that the temperature sensor is defective, causing the fan speed to increase to the maximum. If the sensor wire between the IGBT and the gate drive card is disconnected, this warning would result. Also, check the IGBT thermal sensor.

**ALARM 67, Option module configuration has changed**

One or more options have either been added or removed since the last power-down. Check that the configuration change is intentional and reset the unit.

**ALARM 68, Safe stop activated**

Safe stop has been activated. To resume normal operation, apply 24 V DC to terminal 37, then send a reset signal (via Bus, Digital I/O, or by pressing the reset key).

**ALARM 69, Power card temperature**

The temperature sensor on the power card is either too hot or too cold.

**Troubleshooting**

Check the operation of the door fans.

Check that the filters for the door fans are not blocked.

Check that the gland plate is properly installed on IP21/IP 54 (NEMA 1/12) frequency converters.

**ALARM 70, Illegal frequency converter configuration**

The control card and power card are incompatible. Contact your supplier with the type code of the unit from the nameplate and the part numbers of the cards to check compatibility.

**ALARM 71, PTC 1 safe stop**

Safe Stop has been activated from the PTC Thermistor Card (motor too warm). Normal operation can be resumed when the applies 24 V DC to T-37 again (when the motor temperature reaches an acceptable level) and when the Digital Input from the is deactivated. When that happens, a reset signal must be sent (via Bus, Digital I/O, or by pressing [Reset]). Note that if automatic restart is enabled, the motor may start when the fault is cleared.

**ALARM 72, Dangerous failure**

Safe Stop with Trip Lock. Unexpected signal levels on safe stop and digital input from the PTC thermistor card.

**WARNING 73, Safe stop auto restart**

Safe stopped. With automatic restart enabled, the motor may start when the fault is cleared.

**WARNING 76, Power unit setup**

The required number of power units does not match the detected number of active power units.

**Troubleshooting:**

When replacing an F-frame module, this will occur if the power specific data in the module power card does not match the rest of the frequency converter. Please confirm the spare part and its power card are the correct part number.

**77 WARNING, Reduced power mode**

This warning indicates that the frequency converter is operating in reduced power mode (i.e. less than the allowed number of inverter sections). This warning will be generated on power cycle when the frequency converter is set to run with fewer inverters and will remain on.

**ALARM 79, Illegal power section configuration**

The scaling card is the incorrect part number or not installed. Also MK102 connector on the power card could not be installed.

**ALARM 80, Drive initialised to default value**

Parameter settings are initialised to default settings after a manual reset. Reset the unit to clear the alarm.

**ALARM 81, CSIV corrupt**

CSIV file has syntax errors.

**ALARM 82, CSIV parameter error**

CSIV failed to init a parameter.

**ALARM 85, Dang fail PB:**

Profibus/Profisafe Error.

**WARNING/ALARM 104, Mixing fan fault**

The fan monitor checks that the fan is spinning at drive power-up or whenever the mixing fan is turned on. If the fan is not operating, then the fault is annunciated. The mixing-fan fault can be configured as a warning or an alarm trip by parameter 14-53 (Fan Monitor).

**Troubleshooting** Cycle power to the frequency converter to determine if the warning/alarm returns.

**ALARM 243, Brake IGBT**

This alarm is only for F Frame frequency converters. It is equivalent to Alarm 27. The report value in the alarm log indicates which power module generated the alarm:

- 1 = left most inverter module.
- 2 = middle inverter module in F12 or F3 frame sizes .
- 2 = right inverter module in F10 or F11 frame sizes.
- 2 = second drive from the left inverter module in F14 frame size.
- 3 = right inverter module in F12 or F13 frame sizes.
- 3 = third from the left inverter module in F14 frame size.
- 4 = far right inverter module in F14 frame size.
- 5 = rectifier module.
- 6 = right rectifier module in F14 frame size.

**ALARM 244, Heatsink temperature**

This alarm is only for F Frame frequency converters. It is equivalent to Alarm 29. The report value in the alarm log indicates which power module generated the alarm.

- 1 = left most inverter module.
- 2 = middle inverter module in F12 or F3 frame sizes .
- 2 = right inverter module in F10 or F11 frame sizes.
- 2 = second drive from the left inverter module in F14 frame size.
- 3 = right inverter module in F12 or F13 frame sizes.
- 3 = third from the left inverter module in F14 frame size.
- 4 = far right inverter module in F14 frame size.
- 5 = rectifier module.
- 6 = right rectifier module in F14 frame size.

**ALARM 245, Heatsink sensor**

This alarm is only for F Frame frequency converters. It is equivalent to Alarm 39. The report value in the alarm log indicates which power module generated the alarm

- 1 = left most inverter module.
- 2 = middle inverter module in F12 or F3 frame sizes .
- 2 = right inverter module in F10 or F11 frame sizes.
- 2 = second drive from the left inverter module in F14 frame size.
- 3 = right inverter module in F12 or F13 frame sizes.
- 3 = third from the left inverter module in F14 frame size.
- 4 = far right inverter module in F14 frame size.
- 5 = rectifier module.
- 6 = right rectifier module in F14 frame size.

**ALARM 246, Power card supply**

This alarm is only for F Frame frequency converter. It is equivalent to Alarm 46. The report value in the alarm log indicates which power module generated the alarm

- 1 = left most inverter module.
- 2 = middle inverter module in F12 or F3 frame sizes .
- 2 = right inverter module in F10 or F11 frame sizes.
- 2 = second drive from the left inverter module in F14 frame size.
- 3 = right inverter module in F12 or F13 frame sizes.
- 3 = third from the left inverter module in F14 frame size.
- 4 = far right inverter module in F14 frame size.
- 5 = rectifier module.
- 6 = right rectifier module in F14 frame size.

**ALARM 69, Power card temperaturePower card temperature**

This alarm is only for F Frame frequency converter. It is equivalent to Alarm 69. The report value in the alarm log indicates which power module generated the alarm

- 1 = left most inverter module.
- 2 = middle inverter module in F12 or F3 frame sizes .
- 2 = right inverter module in F10 or F11 frame sizes.
- 2 = second drive from the left inverter module in F14 frame size.

- 3 = right inverter module in F12 or F13 frame sizes.
- 3 = third from the left inverter module in F14 frame size.
- 4 = far right inverter module in F14 frame size.
- 5 = rectifier module.
- 6 = right rectifier module in F14 frame size.

**ALARM 248, Illegal power section configuration**

This alarm is only for F Frame frequency converters. It is equivalent to Alarm 79. The report value in the alarm log indicates which power module generated the alarm:

- 1 = left most inverter module.
- 2 = middle inverter module in F12 or F3 frame sizes .
- 2 = right inverter module in F10 or F11 frame sizes.
- 2 = second drive from the left inverter module in F14 frame size.
- 3 = right inverter module in F12 or F13 frame sizes.
- 3 = third from the left inverter module in F14 frame size.
- 4 = far right inverter module in F14 frame size.
- 5 = rectifier module.
- 6 = right rectifier module in F14 frame size.

**WARNING 250, New spare part**

A component in the frequency converter has been replaced. Reset the frequency converter for normal operation.

**WARNING 251, New typecode**

The power card or other components have been replaced and the typecode changed. Reset to remove the warning and resume normal operation.

Index

<b>A</b>	
Abbreviations.....	4
Access To Control Terminals.....	46
Airflow.....	23
AMA.....	52, 105, 108
<b>Analog</b>	
Inputs.....	104, 95
Output.....	96
Signal.....	104
Approvals.....	3
Automatic Motor Adaptation (AMA).....	52, 58
<b>B</b>	
Back Cooling.....	23
<b>Brake</b>	
Cable.....	40
Resistor Temperature Switch.....	46
Braking.....	106
<b>C</b>	
Cable Lengths And Cross Sections.....	97
Cable-length And Cross-section.....	29
Cabling.....	27
Communication Option.....	107
<b>Control</b>	
Cables.....	51, 49
Card.....	104
Card Performance.....	97
Card, +10V DC Output.....	96
Card, 24V DC Output.....	96
Card, RS-485 Serial Communication.....	97
Card, USB Serial Communication.....	97
Characteristics.....	97
Terminals.....	46
Cooling.....	23
Current Rating.....	104
<b>D</b>	
DC Link.....	104
Default Settings.....	60
Derating.....	105
DeviceNet.....	3
<b>Digital</b>	
Input.....	105
Inputs.....	94
Output.....	96
Disposal Instruction.....	3
Drives With Factory Installed Brake Chopper Option.....	40
Duct Cooling.....	23
<b>E</b>	
Earth Leakage Current.....	5
Earthing.....	38
ELCB Relays.....	38
Electrical Installation.....	46, 49
<b>External</b>	
Fan Supply.....	41
Temperature Monitoring.....	27
<b>F</b>	
Feedback.....	108
Fieldbus Connection.....	46
Frame Size F Panel Options.....	26
Fuses.....	107, 42
Fusing.....	27
<b>G</b>	
<b>General</b>	
Considerations.....	15
Warning.....	5
Gland/Conduit Entry - IP21 (NEMA 1) And IP54 (NEMA12)...	23
Graphical Display.....	55
<b>H</b>	
High Power Fuse Tables 12-Pulse.....	42
<b>I</b>	
<b>Input</b>	
Polarity Of Control Terminals.....	51
Terminals.....	104
Installation Of 24 V External DC Supply.....	46
Insulation Resistance Monitor (IRM).....	26
IT Mains.....	38
<b>L</b>	
<b>Language</b>	
Package 1.....	57
Package 2.....	57
Package 3.....	57
Package 4.....	57
LCP.....	55
LEDs.....	55
Lifting.....	8
<b>M</b>	
Main Reactance.....	58
<b>Mains</b>	
Connection.....	40
Supply (L1, L2, L3).....	94



Index	VLT® Automation Drive FC 300 12-Pulse Operating Instructions High Power
<b>Manual Motor Starters</b> .....	26
<b>Mechanical</b>	
Brake Control.....	53
Dimensions.....	14, 10
Installation.....	15
<b>Motor</b>	
Cable.....	39
Current.....	108
Data.....	105, 108
Name Plate.....	52
Output.....	94
Overload Protection.....	5
Power.....	108
Protection.....	98
Thermal Protection.....	54
<b>N</b>	
<b>Name Plate Data</b> .....	52
<b>NAMUR</b> .....	26
<b>O</b>	
<b>Output</b>	
Current.....	104
Performance (U, V, W).....	94
<b>P</b>	
<b>Parallel Connection Of Motors</b> .....	54
<b>Phase Loss</b> .....	104
<b>Planning The Installation Site</b> .....	8
<b>Potentiometer Reference</b> .....	48
<b>Power Connections 12-Pulse Drives</b> .....	27
<b>Profibus</b> .....	3
<b>Programming</b> .....	104
<b>Protection And Features</b> .....	98
<b>Pulse Start/Stop</b> .....	48
<b>Pulse/Encoder Inputs</b> .....	96
<b>R</b>	
<b>RCD (Residual Current Device)</b> .....	26
<b>Receiving The Frequency Converter</b> .....	8
<b>Relay Outputs</b> .....	97
<b>Repair Work</b> .....	5
<b>Reset</b> .....	104, 109
<b>Residual Current Device</b> .....	5
<b>RFI Switch</b> .....	38
<b>S</b>	
<b>Safe</b>	
Stop.....	6
Stop Installation.....	6
<b>Safety</b>	
Category 3 (EN 954-1).....	7
Instructions.....	5
<b>Screened/armoured</b> .....	51
<b>Screening Of Cables</b> .....	29
<b>Serial Communication</b> .....	97
<b>Shielded Cables</b> .....	39
<b>Short Circuit</b> .....	106
<b>Short-circuit Protection</b> .....	42
<b>Sine-wave Filter</b> .....	29
<b>Space</b>	
Space.....	15
Heaters And Thermostat.....	26
<b>Speed Up/Down</b> .....	48
<b>Start/Stop</b> .....	48
<b>Stator Leakage Reactance</b> .....	58
<b>Status Messages</b> .....	55
<b>Stopping Category 0 (EN 60204-1)</b> .....	7
<b>Supply Voltage</b> .....	107
<b>Surroundings</b> .....	98
<b>Switches S201, S202, And S801</b> .....	52
<b>Switching Frequency</b> .....	105, 29
<b>Symbols</b> .....	3
<b>T</b>	
<b>Thermistor</b> .....	105
<b>Tightening Torques</b> .....	38
<b>Torque</b>	
Torque.....	38
Characteristics.....	94
<b>Troubleshooting</b> .....	104
<b>U</b>	
<b>Unintended Start</b> .....	6
<b>Unpacking</b> .....	8
<b>V</b>	
<b>Voltage</b>	
Imbalance.....	104
Level.....	94
Reference Via A Potentiometer.....	48
<b>W</b>	
<b>Warning And Alarm Definitions</b> .....	104
<b>Wire Access</b> .....	15