



Installation Guide

VLT[®] Programmable I/O MCB 115

VLT[®] AutomationDrive FC 301/302



Contents

1 Introduction	2
1.1 Purpose of the manual	2
1.2 Additional Resources	2
1.3 Document and Software Version	2
1.4 Product Overview	2
1.4.1 Intended Use	2
1.4.2 Foreseeable Misuse	2
1.5 Disposal	3
1.6 Symbols, Abbreviations and Conventions	3
2 Safety	4
2.1 Safety Symbols	4
2.2 Qualified Personnel	4
2.3 Safety Precautions	4
3 Installation	5
3.1 Safety Instructions	5
3.2 Mounting	5
3.3 Electrical Installation	6
3.3.1 Specifications	6

1 Introduction

1.1 Purpose of the manual

This manual provides information for safe installation of a VLT® Programmable I/O MCB 115 used in the VLT® frequency converter.

The installation guide is intended for use by qualified personnel only. Users must be familiar with the VLT® frequency converter.

Read and follow the instructions before installation, and ensure that instructions for safe installation are observed. Keep these operating instructions available with the frequency converter at all times.

VLT® is a registered trademark.

1.2 Additional Resources

Resources available for the frequency converters and optional equipment:

- The *VLT® Operating Instructions* provide the necessary information for getting the frequency converter up and running.
- The *VLT® Design Guide* provides detailed information about capabilities and functionality to design motor control systems.
- The *VLT® Programming Guide* provides greater detail on working with parameters and many application examples.
- The *VLT® Programmable I/O MCB 115 Installation Guide* provides information about installing the MCB 115.

Supplementary publications and manuals are available from Danfoss. See vlt-drives.danfoss.com/Support/Technical-Documentation/ for listings.

1.3 Document and Software Version

This manual is regularly reviewed and updated. All suggestions for improvement are welcome. Send suggestions via email to techcom_change_request@danfoss.com, including a reference to the document version. *Table 1.1* shows the document version and the changes applied.

Edition	Remarks
MG35R1xx	First edition.

Table 1.1 Document Version

1.4 Product Overview

1.4.1 Intended Use

This installation guide relates to VLT® Programmable I/O MCB 115 B-option with coated PCB, ordering number 130B1266.

The VLT® Programmable I/O MCB 115 is intended to:

- Extend the I/O selection available on the control card, for example, for multi-zone control with 3 pressure transmitters.
- Turn the frequency converter into a decentralised I/O block supporting building automation systems with inputs and outputs.
- Support the extended PI controllers with I/Os for setpoint inputs, transmitter/sensor inputs, and outputs for actuators.
- Provide a digital output used for:
 - Driving a relay.
 - Input to commonly used PLC I/O cards.
 - Input to another frequency converter in a sequential controlled application.

The VLT® Programmable I/O MCB 115 is intended for use with:

- VLT® AutomationDrive FC 301
- VLT® AutomationDrive FC 302

NOTICE

The VLT® Programmable I/O MCB 115 is only functional if it is built into the frequency converter. The option cannot be used as a stand-alone.

1.4.2 Foreseeable Misuse

Any use not expressly approved by Danfoss constitutes misuse. This statement also applies to failure to comply with the specified operating conditions and applications.

Danfoss assumes no liability of any sort for damage attributable to improper use.

1.4.3 Items Supplied

When the VLT® Programmable I/O MCB 115 is not factory-mounted, the following items are supplied:

- VLT® Programmable I/O MCB 115 B-option
- LCP cradle
- Front cover
- Stickers for front cover
- Installation Guide

1.5 Disposal

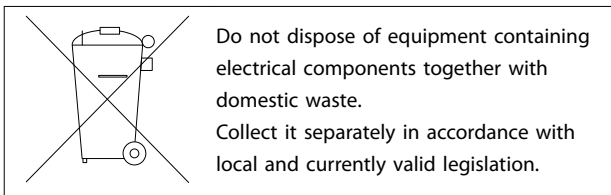

1.6 Symbols, Abbreviations and Conventions

Abbreviation	Definition
I/O	Input/Output
LCP	Local control panel
PI	Proportional Integral
PLC	Programmable logic controller

Table 1.2 Symbols and Abbreviations

Conventions

Numbered lists indicate procedures.

Bullet lists indicate other information and description of illustrations.

Italicised text indicates:

- Cross-reference.
- Link.
- Footnote.
- Parameter name.
- Parameter group name.
- Parameter option.

2

2 Safety

2.1 Safety Symbols

The following symbols are used in this manual:

▲WARNING

Indicates a potentially hazardous situation that could result in death or serious injury.

▲CAUTION

Indicates a potentially hazardous situation that could result in minor or moderate injury. It can also be used to alert against unsafe practices.

NOTICE

Indicates important information, including situations that can result in damage to equipment or property.

2.2 Qualified Personnel

The products must only be assembled, installed, programmed, commissioned, maintained, and decommissioned by persons with proven skills. Persons with proven skills:

- Are qualified electrical engineers, or persons who have received training from qualified electrical engineers and are suitably experienced to operate devices, systems, plant, and machinery in accordance with the general standards and guidelines for safety technology.
- Are familiar with the basic regulations concerning health and safety/accident prevention.
- Have read and understood the safety guidelines given in this manual and also the instructions given in the operating instructions of the frequency converter.
- Have a good knowledge of the generic and specialist standards applicable to the specific application.

2.3 Safety Precautions

▲WARNING

UNINTENDED START

When the frequency converter is connected to AC mains, DC supply, or load sharing, the motor may start at any time. Unintended start during programming, service, or repair work can result in death, serious injury, or property damage. The motor can start with an external switch, a fieldbus command, an input reference signal from the LCP or LOP, via remote operation using MCT 10 Set-up Software, or after a cleared fault condition.

To prevent unintended motor start:

- Disconnect the frequency converter from the mains.
- Press [Off/Reset] on the LCP before programming parameters.
- The frequency converter, motor, and any driven equipment must be fully wired and assembled when the frequency converter is connected to AC mains, DC supply, or load sharing.

▲CAUTION

RISK OF INJURY AND EQUIPMENT DAMAGE

Read and observe these operating instructions and safety warnings before installing the VLT® Programmable I/O MCB 115. Not adhering to the instructions and warnings in this manual may lead to personal injury, and property and equipment damage.

3 Installation

3.1 Safety Instructions

⚠ WARNING

ELECTRICAL HAZARD

Do not open the enclosure of the frequency converter. The frequency converter contains DC-link capacitors that can remain charged even when the frequency converter is not powered. Failure to wait the specified discharge time (see relevant frequency converter operating instructions) after power has been removed before performing service or repair work, can result in death or serious injury.

⚠ WARNING

UNINTENDED START

The operator or electrical installer is responsible for compliance with all applicable national and local safety regulations.

- Disconnect all electric power, including remote disconnects, and discharge all motor start/run capacitors before servicing.
- Follow proper lock-out/tag-out procedures to ensure that the power cannot be inadvertently energised.

See *chapter 2 Safety* and the relevant frequency converter operating instructions. Also, always observe the instructions provided by the motor manufacturer.

3.2 Mounting

The installation procedure depends on the enclosure size of the frequency converter.

Enclosure Sizes A2, A3, and B3

1. Remove the LCP (local control panel), the terminal cover, and the LCP frame from the frequency converter.
2. Fit the option into slot B.
3. Connect the control cables and relieve the cable. See *chapter 3.3.1 Specifications* for details about wiring.
4. Remove the knock out in the extended LCP frame (supplied).
5. Fit the extended LCP frame and terminal cover on the frequency converter.
6. Fit the LCP or blind cover in the extended LCP frame.
7. Connect power to the frequency converter.
8. Set up the input/output functions in the corresponding parameters.

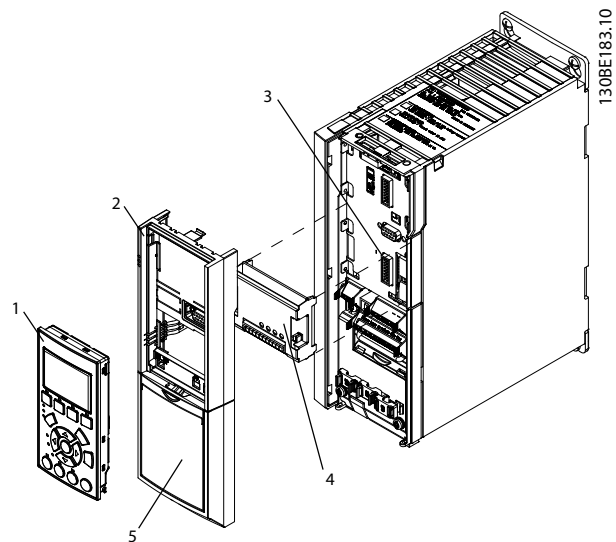

1	LCP
2	Terminal cover
3	Slot B
4	Option
5	LCP frame

Illustration 3.1 Installation in Enclosure Sizes A2, A3, and B3

Enclosure Sizes A5, B1, B2, B4, C1, C2, C3, C4, D, E, and F

1. Remove the LCP (local control panel) and the LCP cradle.
2. Fit the option card into slot B.
3. Connect the control cables and relieve the cable. See *chapter 3.3.1 Specifications* for details about wiring.
4. Fit the cradle on the frequency converter.
5. Fit the LCP in the cradle.

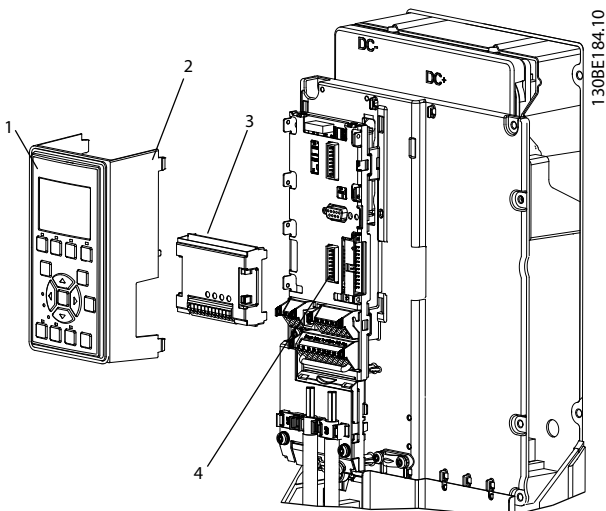

1	LCP
2	LCP cradle
3	Option
4	Slot B

Illustration 3.2 Installation in Enclosure Sizes A5, B1, B2, B4, C1, C2, C3, C4, D, E, and F

3.3 Electrical Installation

3.3.1 Specifications

The VLT® Programmable I/O MCB 115 has 3 programmable inputs/outputs which extend the number of inputs and outputs available for the frequency converter.

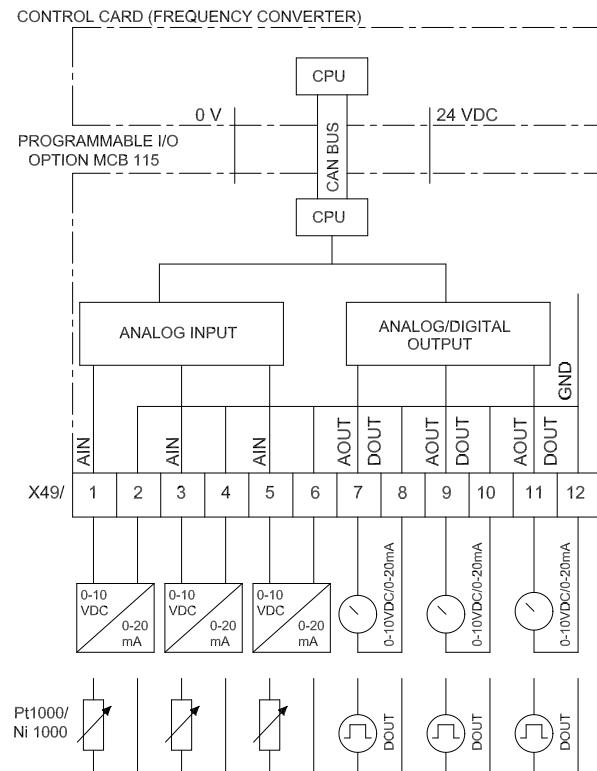

130BA405.11

Illustration 3.3 Input and Output Block Diagram

Programmable inputs

They analog inputs can be used for reference or process feedback for PID controllers.

They can work as:

- Analog voltage inputs.
- Analog current inputs.
- Analog temperature inputs.

	Used as temperature sensor input	Used as analog voltage input	Used as current input
Number of inputs	3	3	3
Terminal	X49/1-6	X49/1-6	X49/1-6
Voltage/current range	-	0-10 V DC or 2-10 V DC	0-20 mA or 4-20 mA
Temperature sensor (1000 Ω at 0 °C)	Ni1000 (according to DIN 43760)	-	-
	Pt1000 (according to IEC 60751)	-	-
Accuracy	-50 °C ±1 Kelvin +150 °C ±2 Kelvin	Better than 1% of full scale	Better than 1% of full scale
Temperature range	-50 °C to +150 °C		
Resolution	10 bits	10 bits	10 bits
Sampling	3 Hz	2 Hz minimum	2 Hz minimum
Maximum load	-	±28 V continuously	±29 mA continuously
Impedance	-	10 kΩ	200 Ω

Table 3.1 Programmable Inputs

NOTICE

- Maximal cables length for temperature sensors is 50 metres non-screened/non-twisted wires.
- Keep cable impedance low as every 3.85 Ω in cable gives a misreading of 1 Kelvin.

Programmable outputs

VLT® Programmable I/O MCB 115 has 3 outputs which can work as:

- Analog voltage outputs.
- Analog current outputs.
- Digital outputs.

	Used as digital output	Used as analog voltage output	Used as current output
Number of outputs	3	3	3
Terminal	X49/7-12	X49/7-12	X49/7-12
Voltage/current range	<ul style="list-style-type: none"> • Maximum voltage at low output: 4 V • Minimum voltage at high output: 20 V • Max output current 24 mA 	0-10 V DC	0-20 mA
Accuracy	-	Better than ±1%	Better than ±1%
Resolution	-	10 bits	10 bits
Maximum load	-	±28 V continuously	±29 mA continuously
Load impedance	-	≥10 kΩ	≤200 Ω

Table 3.2 Programmable Outputs

Terminals

There are 3 inputs and 3 outputs on the option:

- Inputs: X49/1+2, X49/3+4, and X49/5+6
- Outputs: X49/7+8, X49/9+10, and X49/11+12

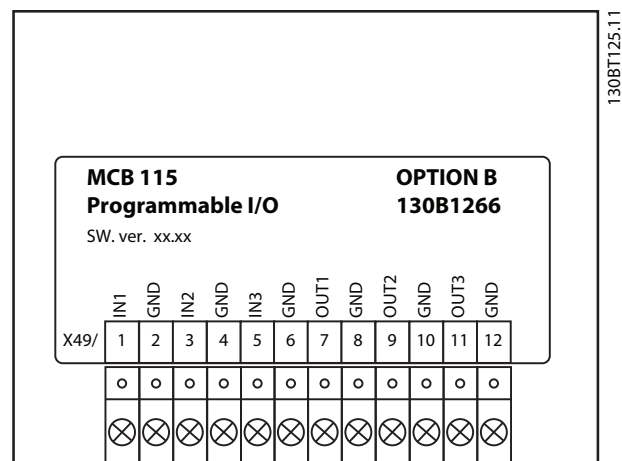

Illustration 3.4 Terminal X49



.....
Danfoss can accept no responsibility for possible errors in catalogues, brochures and other printed material. Danfoss reserves the right to alter its products without notice. This also applies to products already on order provided that such alterations can be made without subsequential changes being necessary in specifications already agreed. All trademarks in this material are property of the respective companies. Danfoss and the Danfoss logotype are trademarks of Danfoss A/S. All rights reserved.
.....

Danfoss A/S
Ulsnaes 1
DK-6300 Graasten
vlt-drives.danfoss.com

