

GE

Installation Guide

Programmable I/O Option OPCPRGIO AF-650 GP™



a product of
ecomagination





Contents

1 Introduction	2
1.1 Purpose of the manual	2
1.2 Additional Resources	2
1.3 Document and Software Version	2
1.4 Product Overview	2
1.4.1 Intended Use	2
1.4.2 Foreseeable Misuse	2
1.5 Disposal	3
1.6 Symbols, Abbreviations, and Conventions	3
2 Safety	4
2.1 Safety Symbols	4
2.2 Qualified Personnel	4
2.3 Safety Precautions	4
3 Installation	5
3.1 Safety Instructions	5
3.2 Mounting	5
3.3 Electrical Installation	6
3.3.1 Specifications	6



1 Introduction

1.1 Purpose of the manual

This manual provides information for safe installation of a Programmable I/O OPCPRGIO used in the AF-650 GP.

The installation guide is intended for use by qualified personnel only. Users must be familiar with the frequency converter.

Read and follow the instructions before installation, and ensure that instructions for safe installation are observed. Keep this installation guide available with the frequency converter at all times.

1.2 Additional Resources

- The *AF-650 GP™ General Purpose Drive Design & Installation Guide* provide the necessary information for getting the frequency converter up and running.
- The *AF-650 GP™ General Purpose Drive Programming Guide* provides greater detail on working with parameters and many application examples.
- The *Programmable I/O OPCPRGIO Installation Guide* provides information about installing the OPCPRGIO.

For additional AF-6 Series Drives information visit www.geindustrial.com/drives.

1.3 Document and Software Version

Table 1.1 shows the document version and the changes applied.

Edition	Remarks
DET-849	First edition.

Table 1.1 Document Version

1.4 Product Overview

1.4.1 Intended Use

This installation guide relates to Programmable I/O OPCPRGIO B option with coated PCB.

The Programmable I/O OPCPRGIO is intended to:

- Extend the I/O selection available on the control card, for example, for multi-zone control with 3 pressure transmitters.
- Turn the frequency converter into a decentralized I/O block supporting building automation systems with inputs and outputs.
- Support the extended PI controllers with I/Os for setpoint inputs, transmitter/sensor inputs, and outputs for actuators.
- Provide a digital output used for:
 - Driving a relay.
 - Input to commonly used PLC I/O cards.
 - Input to another frequency converter in a sequential controlled application.

The Programmable I/O OPCPRGIO is intended for use with:

- AF-650 GP

NOTICE

The Programmable I/O OPCPRGIO is only functional if it is built into the frequency converter. The option cannot be used as stand-alone.

1.4.2 Foreseeable Misuse

Any use not expressly approved by GE constitutes misuse. This statement also applies to failure to comply with the specified operating conditions and applications.

GE assumes no liability of any sort for damage attributable to improper use.



1.4.3 Items Supplied

When the Programmable I/O OPCPRGIO is not factory-mounted, the following items are supplied:

- Programmable I/O OPCPRGIO B-option
- Keypad cradle
- Front cover
- Stickers for front cover
- Installation guide

1.5 Disposal

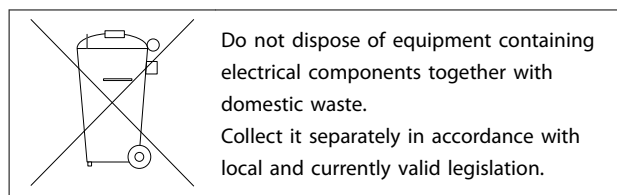

1.6 Symbols, Abbreviations, and Conventions

Abbreviation	Definition
I/O	Input/output
PI	Proportional Integral
PLC	Programmable logic controller

Table 1.2 Symbols and Abbreviations

Conventions

Numbered lists indicate procedures.

Bullet lists indicate other information and description of illustrations.

Italicized text indicates:

- Cross-reference.
- Link.
- Footnote.
- Parameter name.
- Parameter group name.
- Parameter option.



2 Safety

2.1 Safety Symbols

The following symbols are used in this manual:

⚠ WARNING

Indicates a potentially hazardous situation that could result in death or serious injury.

⚠ CAUTION

Indicates a potentially hazardous situation that could result in minor or moderate injury. It can also be used to alert against unsafe practices.

NOTICE

Indicates important information, including situations that can result in damage to equipment or property.

2.2 Qualified Personnel

The products must only be assembled, installed, programmed, commissioned, maintained, and decommissioned by persons with proven skills. Persons with proven skills:

- Are qualified electrical engineers, or persons who have received training from qualified electrical engineers and are suitably experienced to operate devices, systems, plant, and machinery in accordance with the general standards and guidelines for safety technology.
- Are familiar with the basic regulations concerning health and safety/accident prevention.
- Have read and understood the safety guidelines given in this manual and also the instructions given in the operating instructions of the frequency converter.
- Have a good knowledge of the generic and specialist standards applicable to the specific application.

2.3 Safety Precautions

⚠ WARNING

UNINTENDED START

When the frequency converter is connected to AC mains, DC supply, or load sharing, the motor may start at any time. Unintended start during programming, service, or repair work can result in death, serious injury, or property damage. The motor can start with an external switch, a fieldbus command, an input reference signal from the keypad, via remote operation using DCT-10, or after a cleared fault condition.

To prevent unintended motor start:

- Disconnect the frequency converter from the mains.
- Press [Off/Reset] on the keypad before programming parameters.
- The frequency converter, motor, and any driven equipment must be fully wired and assembled when the frequency converter is connected to AC mains, DC supply, or load sharing.

⚠ CAUTION

RISK OF INJURY AND EQUIPMENT DAMAGE

Read and observe these operating instructions and safety warnings before installing the Programmable I/O OPCPRGIO. Not adhering to the instructions and warnings in this manual may lead to personal injury, and property and equipment damage.

3 Installation

3.1 Safety Instructions

⚠ WARNING

ELECTRICAL HAZARD

Do not open the enclosure of the frequency converter. The frequency converter contains DC-link capacitors that can remain charged even when the frequency converter is not powered. Failure to wait the specified discharge time (see relevant frequency converter operating instructions) after power has been removed before performing service or repair work, can result in death or serious injury.

⚠ WARNING

UNINTENDED START

The operator or electrical installer is responsible for compliance with all applicable national and local safety regulations.

- Disconnect all electric power, including remote disconnects, and discharge all motor start/run capacitors before servicing.
- To ensure that the power cannot be inadvertently energized, follow proper lock-out/tag-out procedures.

See *chapter 2 Safety* and the relevant frequency converter operating instructions. Also, always observe the instructions provided by the motor manufacturer.

3.2 Mounting

The installation procedure depends on the unit size of the frequency converter.

Unit sizes 12, 13, and 23

1. Remove the keypad, the terminal cover, and the keypad frame from the frequency converter.
2. Fit the option into slot B.
3. Connect the control cables and relieve the cable. See *chapter 3.3.1 Specifications* for details about wiring.
4. Remove the knockout in the extended keypad frame (supplied).
5. Fit the extended keypad frame and terminal cover on the frequency converter.
6. Fit the keypad or blind cover in the extended keypad frame.
7. Connect power to the frequency converter.
8. Set up the input/output functions in the corresponding parameters.

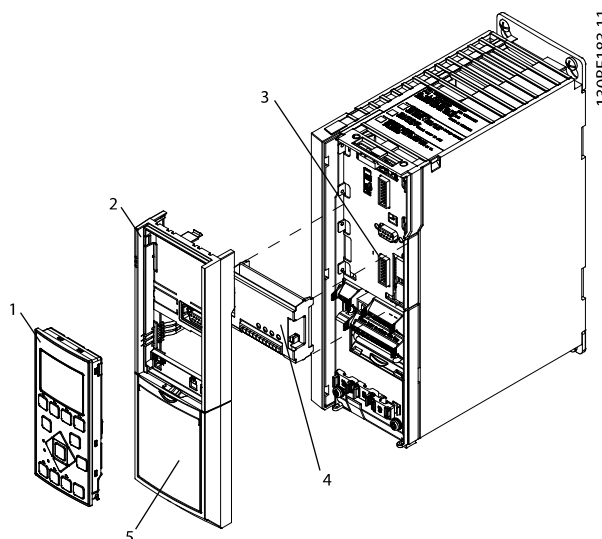

1	Keypad
2	Terminal cover
3	Slot B
4	Option
5	Keypad frame

Illustration 3.1 Installation in Unit Sizes 12, 13, and 23



Enclosure sizes 15, 21, 22, 24, 31, 32, 33, 34, 4x, 4xh, 5x, and 6x

1. Remove the keypad and the keypad cradle.
2. Fit the option card into slot B.
3. Connect the control cables and relieve the cable. See *chapter 3.3.1 Specifications* for details about wiring.
4. Fit the cradle on the frequency converter.
5. Fit the keypad in the cradle.

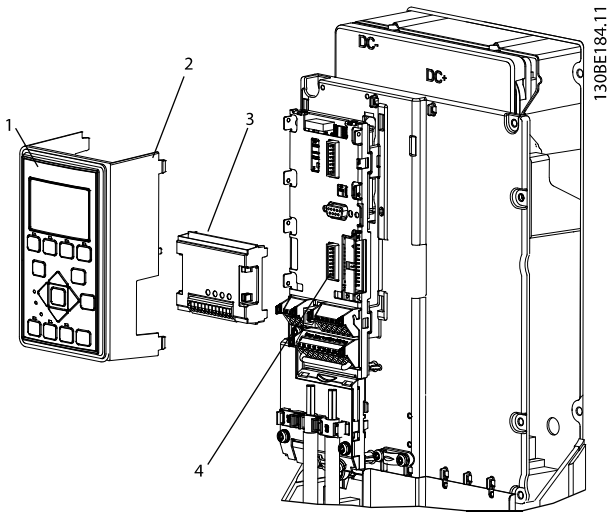

1	Keypad
2	Keypad cradle
3	Option
4	Slot B

Illustration 3.2 Installation in Unit Sizes 15, 21, 22, 24, 31, 32, 33, 34, 4x, 4xh, 5x, and 6x

3.3 Electrical Installation

3.3.1 Specifications

The Programmable I/O OPCPRGIO has 3 programmable inputs/outputs which extend the number of inputs and outputs available for the frequency converter.

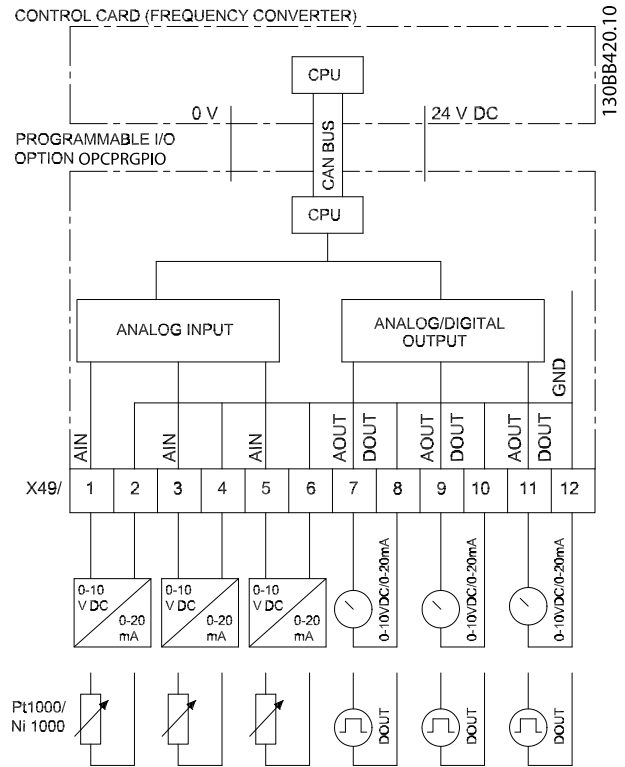

Illustration 3.3 Input and Output Block Diagram

NOTICE

- Maximal cables length for temperature sensors is 50 meters non-screened/non-twisted wires.
- Keep cable impedance low as every 3.85 Ω in cable gives a misreading of 1 Kelvin.



Programmable outputs

The Programmable I/O OPCPRGIO has 3 outputs which can work as:

- Analog voltage outputs.
- Analog current outputs.
- Digital outputs.

	Used as digital output	Used as analog voltage output	Used as current output
Number of outputs	3	3	3
Terminal	X49/7-12	X49/7-12	X49/7-12
Voltage/current range	<ul style="list-style-type: none"> • Maximum voltage at low output: 4 V • Minimum voltage at high output: 20 V • Max output current 24 mA 	0-10 V DC	0-20 mA
Accuracy	-	Better than ±1%	Better than ±1%
Resolution	-	10 bits	10 bits
Maximum load	-	±28 V continuously	±29 mA continuously
Load impedance	-	≥10 kΩ	≤200 Ω

Table 3.1 Programmable Outputs

Terminals

There are 3 inputs and 3 outputs on the option:

- Inputs: X49/1+2, X49/3+4, and X49/5+6
- Outputs: X49/7+8, X49/9+10, and X49/11+12

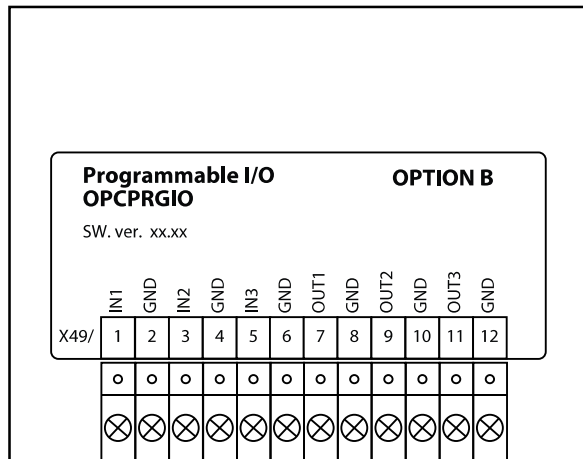

Illustration 3.4 Terminal X49

130BT125.11

The instructions do not purport to cover all details or variations in equipment nor to provide for every possible contingency to be met in connection with installation, operation or maintenance. Should further information be desired or should particular problems arise which are not covered sufficiently for the purchaser's purposes, the matter should be referred to the GE company.

AF-650 GP is trademark of the General Electric Company.

GE
41 Woodford Avenue
Plainville, CT 06062

www.geindustrial.com/drives

