



Operating Instructions Safety Option MCB 152

VLT® AutomationDrive FC 302



Contents

1 Introduction	4
1.1 Purpose of the Manual	4
1.2 Intended Use	4
1.3 Unit Features	4
1.4 Front View	5
1.5 Hardware and Software Requirements	5
1.5.1 Compatibility	5
1.6 Additional Resources	5
1.7 Document Version	5
1.8 Compliance and Certifications	5
1.9 Disposal	5
2 Safety	6
2.1 Safety Symbols	6
2.2 Qualified Personnel	6
2.3 Safety Precautions	6
2.4 Risk Assessment	7
3 Functions	9
3.1 Safety Functions	9
3.1.1 Safe Torque Off - STO	9
3.1.2 Specification of Safety Functions	10
3.1.3 Activation of Safety Functions	10
3.1.4 Activation of STO from Multiple Sources	10
3.1.5 Functional Proof Tests	10
3.1.6 PFD and PFH Definitions	10
3.1.7 Internal Errors	10
3.2 Inputs and Output	11
3.2.1 Permitted Sensor Types on Digital Inputs	11
3.2.2 Inputs	11
3.2.3 Safe Option Monitoring (SO Mon)	11
3.2.4 Output	11
3.2.5 Signal Filtering	11
3.2.6 Stable Signal and Safety Devices	12
4 Installation	13
4.1 Safety Instructions	13
4.2 Installation Overview	13
4.3 Items Supplied	13
4.4 Mounting	13

4.5 Electrical Installation	13
4.5.1 Cabling Requirements	14
4.5.2 Connector Pin Assignment	14
4.5.3 Wiring Procedures	14
4.6 Installation Checklist	15
5 Commissioning	16
5.1 Before Commissioning	16
5.2 Commissioning Requirements	16
5.3 Commissioning Procedure	16
5.3.1 Power-up/Self-test	16
5.3.2 Commissioning in Online Mode	16
5.4 Commissioning Test	18
5.4.1 Preconditions for Performing the Commissioning Test	18
5.5 Operation	18
5.6 Commissioning Set-up Examples	19
6 Configuring the Safety Option	20
6.1 PROFIsafe Configuration	20
6.1.1 Telegram Configuration	20
6.1.2 Safety Functions Configuration	20
6.1.3 Password Protection	20
6.2 Status over Fieldbus	21
6.2.1 Safety Option Reset via Control Word	21
6.2.2 Safety Option Status	21
6.3 Reset Function	22
6.3.1 Reset Input (DI2)	22
6.4 Configuring PROFIsafe with Siemens Step 7	23
6.5 Configuring PROFIsafe with Siemens TIA Portal	24
6.5.1 Configure the Hardware	24
7 Parameter Set-up	25
7.1 Parameter List	25
8 Application Examples	31
8.1 Connecting Safe Digital Inputs	31
9 Maintenance, Diagnostics and Troubleshooting	33
9.1 Maintenance and Service	33
9.1.1 Yearly Test	33
9.2 Repair and Troubleshooting	33
9.2.1 Removing the Safety Option	33

9.2.2 Replacing the Safety Option	34
9.2.3 Mismatch of Safety Option Parameters	34
9.2.4 Copying Safe Parameter Configuration	35
9.3 Error Conditions	36
9.3.1 List of Error Conditions	37
9.4 LCP Messages	40
9.4.1 LCP Status Messages	40
10 Specifications	43
10.1 Consumption	43
10.2 Inputs	43
10.3 Outputs	43
10.4 Other Specifications	43
10.5 Safety Characteristic Data	44
11 Appendix	45
11.1 Abbreviations and Conventions	45
Index	46

1 Introduction

1.1 Purpose of the Manual

These operating instructions provide information for safe installation and commissioning of the Safety Option MCB 152 for PROFIsafe communication.

The operating instructions are intended for use by qualified personnel, see *chapter 2.2 Qualified Personnel*. Read and follow the operating instructions to use the safety option safely and professionally, and pay particular attention to the safety instructions and general warnings. Keep these operating instructions available with the safety option at all times.

1.2 Intended Use

Safety Option MCB 152 is designed to activate and deactivate safety functions of a frequency converter through the PROFIsafe fieldbus. To use the fieldbus, the *VL^T® PROFINET MCA 120* option is required. The safety functions of the safety option are implemented according to EN IEC 61800-5-2.

The safety option:

- Activates safety functions on request.
- Sends status information to the safety control system via a connected PROFINET fieldbus.
- Activates the safe state when the option detects errors.

The safety option is designed as a standard B option for the *VL^T® AutomationDrive FC 302*.

The safety control system:

- Activates safety functions via inputs on the safety option and/or via the safe fieldbus.
- Evaluates signals from safety devices, such as:
 - E-STOP push buttons.
 - Non-contact Magnetic switch.
 - Interlocking switch.
 - Light curtain devices.

The safety devices are connected to digital inputs of the safety option or digital input of the PLC.

- Provides safe connection between the safety option, and a safety control system.
- Provides error detection on the signal between a safety control system and the safety option at activation of safety functions (shorts across contacts, short circuit).

Illustration 1.1 shows the set-up with the frequency converter, Safety Option MCB 152, PROFINET MCA 120 option, PLC and safe input devices:

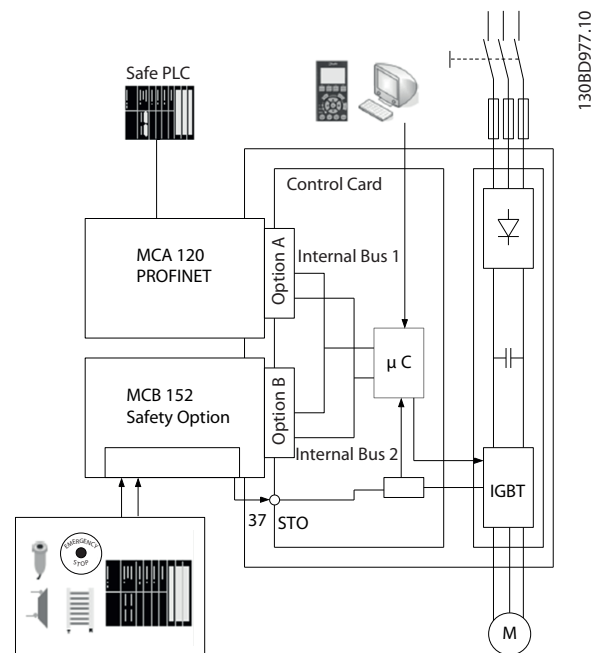

Illustration 1.1 FC 302 with Safety Option MCB 152 and a Fieldbus Option

1.3 Unit Features

The safety option has the following features:

- Safety functions: Safe Torque Off (STO) in accordance with EN IEC 61800-5-2.
- PROFIsafe version 2.4 communication.
- 2 dual-channel digital inputs:
 - Safety function activation.
 - Monitoring.
 - Configurable reset behaviour (automatic or manual reset).
- LED status indication.
- Supply voltage.
 - Internally supplied by the frequency converter.
 - 24 V DC output for safety sensors available.
- Safe output S37.

1.4 Front View

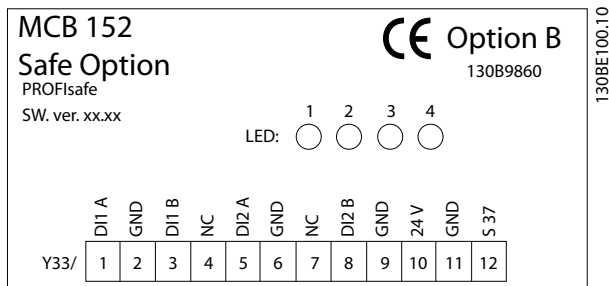

Illustration 1.2 Safety Option MCB 152 Front View.

1.5 Hardware and Software Requirements

The following software versions are required as a minimum for using Safety Option MCB 152:

- LCP software version 7.0.
- FC 302 firmware version 7.26.
- PROFINET software version 3.00.
- MCT 10 Set-up Software version 3.23. A license key is required to use the full set of features.

1.5.1 Compatibility

The safety option is compatible with all VLT® AutomationDrive FC 302 frequency converters in the power range from 0.37 kW-75 kW. Compliance to higher power ranges is pending. Contact the local supplier for latest information.

1.6 Additional Resources

The following documentation on safety option installation and configuration is available:

- *MCT 10 Set-up Software Operating Instructions* describe how to configure the safety option.
- *VLT® AutomationDrive FC 301/FC 302 Operating Instructions* describe the frequency converter.
- *VLT® AutomationDrive PROFINET MCA 120 Installation Guide* describes how to install the PROFINET option.
- *VLT® Frequency Converters Safe Torque Off Operating Instructions* describe the use of DanfossVLT® frequency converters in functional safety applications.

Supplementary publications and manuals are available from Danfoss. See vlt-drives.danfoss.com/Support/Technical-Documentation/ for listings.

1.7 Document Version

This manual is regularly reviewed and updated. All suggestions for improvement are welcome. *Table 1.1* shows the document version.

Edition	Remarks
MG37F1xx	New document

Table 1.1 Document Version

1.8 Compliance and Certifications

The safety option is certified for use in safety applications up to and including

- SIL 2 according to EN IEC 61508 and EN IEC 62061.
- Performance Level PL d.
- Category 3 according to EN ISO 13849-1.

Safety requirements are based on the standards valid at the time of certification. The IFA (Institute for Occupational Safety & Health) has approved the safety option for use in safety-related applications where the de-energised state is considered to be the safe state. All of the examples related to I/O included in this manual are based on achieving de-energisation as the safe state.

Approvals



Safety Option MCB 152 is tested and certified by PNO.

1.9 Disposal

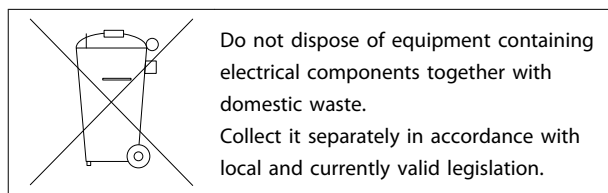

2 Safety

2.1 Safety Symbols

The following symbols are used in this document:



Indicates a potentially hazardous situation that could result in death or serious injury.



Indicates a potentially hazardous situation that could result in minor or moderate injury. It can also be used to alert against unsafe practices.

NOTICE

Indicates important information, including situations that can result in damage to equipment or property.

2.2 Qualified Personnel

The products may only be assembled, installed, programmed, commissioned, maintained, and decommissioned by persons with proven skills. Persons with proven skills

- are qualified electrical engineers, or persons who have received training from qualified electrical engineers and are suitably experienced to operate devices, systems, plant and machinery in accordance with the general standards and guidelines for safety technology.
- are familiar with the basic regulations concerning health and safety/accident prevention.
- have read and understood the safety guidelines given in this manual and also the instructions given in the operating instructions of the frequency converter.
- have a good knowledge of the generic and specialist standards applicable to the specific application.

Users of Power Drive Systems (Safety Related) (PDS(SR)) are responsible for:

- Hazard and risk analysis of the application.
- Identifying safety functions required and allocating SIL or PLr to each of the functions.
- Other subsystems and the validity of signals and commands from them.

- Designing appropriate safety-related control systems (hardware, software, parameterisation, etc.).

Protective measures

- Safety engineering systems may only be installed and commissioned by qualified and skilled personnel.
- Install the frequency converter in an IP54 cabinet as per IEC 60529 or in an equivalent environment. In special applications, a higher IP degree may be necessary.
- Ensure short-circuit protection of the cable between the safety option and the external safety device according to ISO 13849-2 table D.4. When external forces influence the motor axis (for example suspended loads), additional measures (for example a safety holding brake) are required to eliminate hazards.

2.3 Safety Precautions



HIGH VOLTAGE

Frequency converters contain high voltage when connected to AC mains input, DC supply, or load sharing. Failure to perform installation, start-up, and maintenance by qualified personnel can result in death or serious injury.

- Installation, start-up, and maintenance must be performed by qualified personnel only.

⚠ WARNING**UNINTENDED START**

When the frequency converter is connected to AC mains, DC power supply, or load sharing, the motor may start at any time. Unintended start during programming, service or repair work can result in death, serious injury, or property damage. The motor can start by means of an external switch, a serial bus command, an input reference signal from the LCP or LOP, via remote operation using MCT 10 Set-up Software, or after a cleared error condition.

To prevent unintended motor start:

- Disconnect the frequency converter from mains.
- Press OFF on the LCP, before programming parameters.
- The frequency converter, motor, and any driven equipment must be fully wired and assembled when the frequency converter is connected to AC mains, DC power supply, or load sharing.

⚠ WARNING**DISCHARGE TIME**

The frequency converter contains DC-link capacitors, which can remain charged even when the frequency converter is not powered. Failure to wait the specified time after power has been removed before performing service or repair work, can result in death or serious injury.

- Stop motor.
- Disconnect AC mains and remote DC-link power supplies, including battery back-ups, UPS, and DC-link connections to other frequency converters.
- Disconnect or lock PM motor.
- Wait for the capacitors to discharge fully, before performing any service or repair work. The duration of waiting time is specified in the relevant frequency converter operating instructions, *Chapter 2 Safety*.

⚠ WARNING**UNINTENDED MOVEMENT**

When external forces act on the motor, an unwanted movement, for example caused by gravity, can cause a hazard. Failure to take additional measures for fall protection can result in death or serious injury.

- Equip the motor with fall protection, for example additional mechanical brakes.

⚠ WARNING**EMERGENCY OFF**

The STO function does not provide electrical safety, and is not sufficient to implement the Emergency-Off function as defined by EN 60204-1. Failure to implement the Emergency-Off function properly can result in death or serious injury.

- Ensure safe isolation of electricity, for example by installing an emergency stop contactor to disconnect mains.

⚠ CAUTION

The operator or electrical installer is responsible for proper grounding and compliance with all applicable national and local safety regulations.

2.4 Risk Assessment

⚠ CAUTION

The Safety Option MCB 152 is intended to be part of the safety-related control system of a machine. Before installation, perform a risk assessment to determine whether the specifications of this safety option are suitable for all foreseeable operational and environmental characteristics for the system in which it must be installed.

The user of the control system is responsible for the following:

- The set-up, safety rating and validation of any sensors or actuators connected to the system.
- Completing a system-level risk assessment and reassessing the system any time a change is made.
- Ensuring (as needed for the application) that the system fulfils a desired safety rating.
- Programming the application software and the safety option configurations in accordance with the information in this manual.
- Access to the control system.
- Access to Safety Option MCB 152 customisation (configuration changes).
- Analysing all configuration settings and selecting the proper setting to achieve the required safety rating.

2

2.4.1 Validation of Performance Level

Ensure that the required performance level, determined in the risk assessment, is achieved by the selected system for each safety function used.

- Validate the performance level using the SISTEMA SW Tool of IFA (Institute for Occupational Safety & Health).
- Use the Danfoss SISTEMA library for the calculation. For information about the SISTEMA library, see www.danfoss.com/BusinessAreas/Drives-Solutions/SISTEMA/SISTEMA.htm.
- Contact Danfoss for support in validating the performance level.

When using other methods for validating the performance level, use the characteristic safety values specified in *chapter 10.5 Safety Characteristic Data*.

3 Functions

3.1 Safety Functions

International standards EN ISO 13850 and EN IEC 60204-1 specify the functional requirements and design principles of emergency stop devices.

In control systems where there is a risk of equipment damage or personal injury, safety related parts of control systems (SRP/CS) are required to minimise the risk. SRP/CS include the following general components:

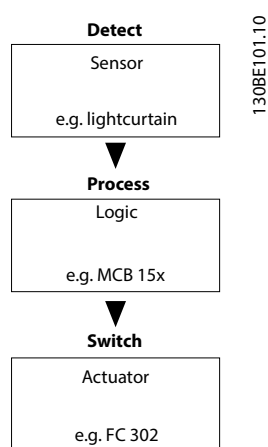

Illustration 3.1 Sensor-Logic-Actuator Safety Chain

Safety functions are defined on the basis of both the application and the hazard. They are often specified in a Type C standard (a product standard) which provides precise specifications for special machines. If a C standard is not available, the machine designer defines the safety functions. Typical safety functions are described in more detail in EN ISO 13849-1, section 5, *Specification of Safety Functions*. The safety functions for frequency converter systems are described in IEC 61800-5-2.

NOTICE

When designing the machine application, consider timing and distance for a coast to stop (Stop Category 0 or Safe Torque Off). For more information regarding stop categories, refer to EN IEC 60204-1.

3.1.1 Safe Torque Off - STO

The safety function STO disconnects power to the motor. It is implemented via the frequency converter's shutdown path and the safety option's safe output.

Features of the safety function:

- The motor becomes torque-free and no longer generates any hazardous movements.
- The safety function STO corresponds to a category 0 stop (uncontrolled stop) in accordance with EN IEC 60204-1.

Prerequisites for normal operation:

- The safe PLC gave an acknowledgement for operation of safety inputs.
- STO is not activated through the safe fieldbus.
- STO is not activated via inputs DI1 or DI2 if those inputs are configured.
- PROFIsafe communication is established and functional.
- The safety option detected no errors and there is no pending safety function.

When the prerequisites for normal operation are met, safe output S37 is active (signal 1, +24 V DC).

Safety function is activated in the following cases:

- An internal error on the safety option.
- Power-up self test (PUST).
- External errors at digital inputs.
- Changes in configuration via MCT 10 Safe Plug-in if the current frequency converter is running.
- There is a 1/0 transition on a digital input or the STO signal through the safe fieldbus.
- PROFIsafe communication is not established.

STO disables the control voltage of the frequency converter output. This prevents the frequency converter from generating the voltage required to rotate the motor (see *Illustration 3.2*). STO is suitable for performing mechanical work on the frequency converter system or affected area of a machine only. It does not provide electrical safety. STO should not be used as a control for starting and/or stopping the frequency converter.

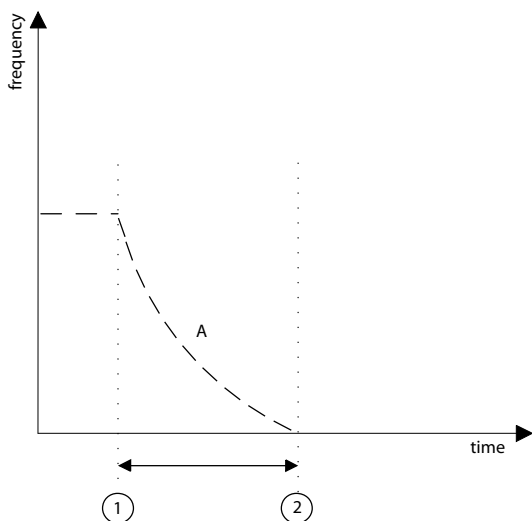

130BC318.10

A	Actual frequency
1	Activation of Safe Torque Off
2	Motor standstill

Illustration 3.2 Safe Torque Off

3.1.2 Specification of Safety Functions

The safety function specification contains details about each safety function that should be executed, for instance:

- Required interfaces with other control functions.
- Required error responses.
- Performance level required (PLr) or safety integrity level (SIL).

3.1.3 Activation of Safety Functions

The safety functions are activated using the dual-channel safe inputs on the safety option or using the PROFIsafe communication.

These inputs operate in accordance with the idle current principle (activate when switching off). The safety control system activates the safety functions via a 1/0 transition.

3.1.4 Activation of STO from Multiple Sources

If multiple sources activate STO (via digital inputs and safe fieldbus), all sources must deactivate STO in the safety option to return to normal operation. After all sources deactivate STO, a reset of the safety option might be required depending on the settings of the digital inputs.

3.1.5 Functional Proof Tests

The functional safety standards require that functional proof tests are performed on the equipment used in the system. Proof tests are performed at user-defined intervals, and are dependent on PFD and PFH values.

3.1.6 PFD and PFH Definitions

Safety-related systems can be classified as operating in either a low demand mode, or in a high demand/continuous mode.

Low demand mode

The frequency of operation made on a safety-related system is not higher than once per year. The SIL value for a low demand safety-related system is directly related to order-of-magnitude ranges of its average probability of failure on demand (PFD).

High demand/continuous mode

The frequency of operation made on a safety-related system is higher than once per year. The SIL value for a high demand/continuous mode safety-related system is directly related to the probability of a dangerous failure per hour (PFH).

3.1.7 Internal Errors

Any internal error in the safety option activates the safety function STO. The frequency converter coasts the motor.

Internal errors always require a power cycle of the frequency converter to reset the error. Alternatively, use *42-90 Restart Safe Option* to restart the safety option after internal error without power cycling the frequency converter.

3.2 Inputs and Output

3.2.1 Permitted Sensor Types on Digital Inputs

The following list describes how digital inputs are activated depending on sensor types:

- NCNC: A digital input is active when there is 0 V at both channels of the input.
- Antivalent: A digital input is active only when there is 0 V at channel A and 24 V at channel B.
- NC: The functionality is similar to NCNC.

Sensors with 2 NO contacts are not applicable.

The safe digital inputs are configured for both directly connected safety sensors, e.g. emergency stop control devices or light curtains, as well as for pre-processing safety relays, for example safe controls. See examples of connecting the safe digital input, in accordance with EN ISO 13849-1 and EN IEC 62061 in *chapter 8.1 Connecting Safe Digital Inputs*.

3.2.2 Inputs

The dual channel digital inputs are used to activate the safety functions.

1 or both digital inputs can be disabled.

DI 1 can have 1 of the following functions:

- STO: Safe Torque Off.
- SO Mon: Safe option monitoring through the safe fieldbus.

DI 2 can have 1 of the following functions:

- STO: Safe Torque Off.
- SO Mon: Safe option monitoring.
- Reset: Additional safe input to reset the safety option after an error, or after deactivating a safety function on input DI1.

3.2.3 Safe Option Monitoring (SO Mon)

The PLC can use the digital inputs of the safety option as safe inputs. If a digital input is set to *Safe Option Monitoring (SO Mon)*, the safety option maintains all signal checks (discrepancy, etc.) on the digital inputs, but the safety option does not activate safety functions in case of a signal change. All safety logic is carried out by the PLC.

3.2.4 Output

S37 is the safe, single-channel output that goes to the STO input of the frequency converter. For information about the events that trigger STO, see *chapter 3.1.1 Safe Torque Off - STO*.

3.2.5 Signal Filtering

If a sensor with NC-NC or antivalent is selected, the safety option checks the signals of the safe digital input for consistency. If NC-NC is selected, consistent signals at both inputs always assume the same signal state (high or low). If antivalent is selected, it checks the correct state of each input.

With electromechanical sensors (for example emergency stop buttons or door switches), the 2 sensor contacts are never activated at the same time due to discrepancy. A long-term discrepancy leads to a fault in the wiring of a safe input, for example, a wire break. An adjustable filter in the safety option prevents errors caused by temporary or short-term discrepancy. Within the filter tolerance time *42-22 Discrepancy Time*, the safety option suppresses the discrepancy when monitoring the safe inputs.

If the signals have different levels after the discrepancy time expires, the option responds with an external error.

NOTICE

The discrepancy time does not extend the safety option response time. The safety option activates its safety function as soon as there is a signal transition on one of the 2 channels of a digital input.

3

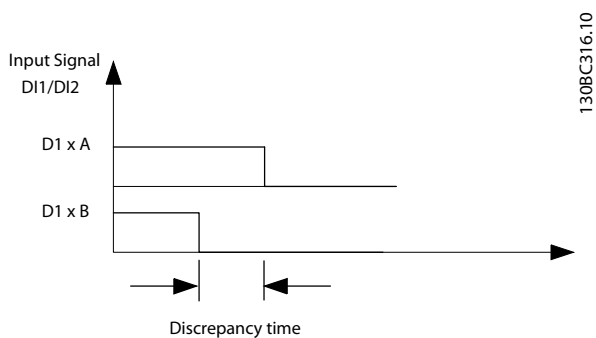

Illustration 3.3 Discrepancy Time

Definition of a stable signal

Following a change to the DI input signals, the option triggers an internal monitoring time. Use 42-23 *Stable Signal Time* to select the appropriate stable signal time. A stable signal is a high or a low signal state, which lasts for the time defined in 42-23 *Stable Signal Time*.

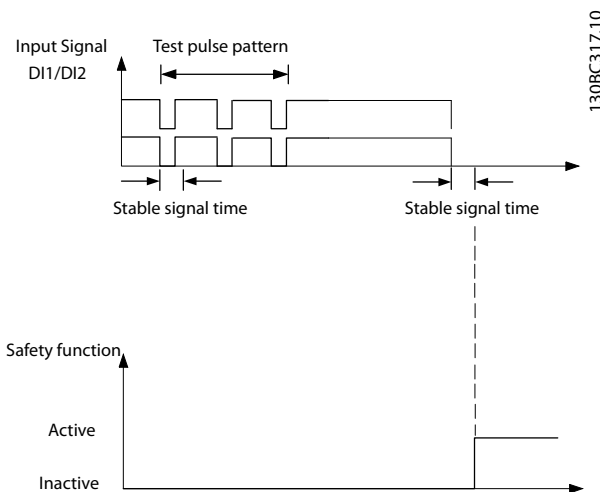

Illustration 3.4 Filter for Suppressing Temporary Signal Changes

3.2.6 Stable Signal and Safety Devices

The safety option normally responds immediately to signal changes at its safe inputs DI1 or DI2. This response is not required in the following cases:

- When interconnecting the safe input of the option with an electromechanical sensor, contact bounce may result in signal changes, to which the option can respond.
- Several control modules test their safe outputs using test pulse patterns (on/off tests), to identify errors due to either short- or cross- circuiting. When interconnecting the safe input of the option with a safe output of a control module, the option can respond to these test signals.

A signal change during a test pulse pattern usually lasts 1 ms.

Under stable signal time, short pulses, which can lead to safety functions being incorrectly activated, can be filtered.

NOTICE

The stable signal time extends the safety option response time. The safety option only activates the safety function after the response time has expired.

If the signal to the input on safety option is not stable, the option responds with an external error after the stable signal time expires.

4 Installation

4.1 Safety Instructions

See *chapter 2 Safety* for general safety instructions.

4.2 Installation Overview

This section contains the general overview of the installation and commissioning process.

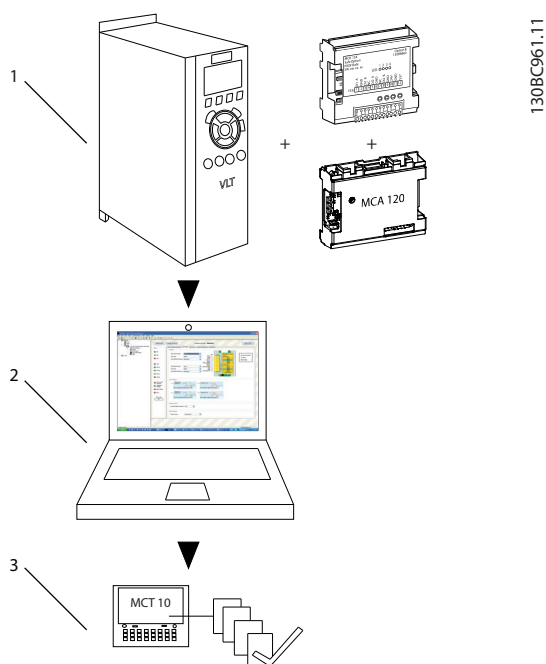

1	Install the safety option
2	Set-up parameters
3	Commission

Illustration 4.1 Installation and Commissioning Overview

4.3 Items Supplied

- Safety Option MCB 152.
- Safety Option MCB 152 Operating Instructions.

4.4 Mounting

CAUTION

Place the VLT® AutomationDrive FC 302 with the safety option, including the connection between output S37 (Y32/12 on Safety Option MCB 152) and input terminal 37 (X44/12 on the control card) in an IP54 environment.

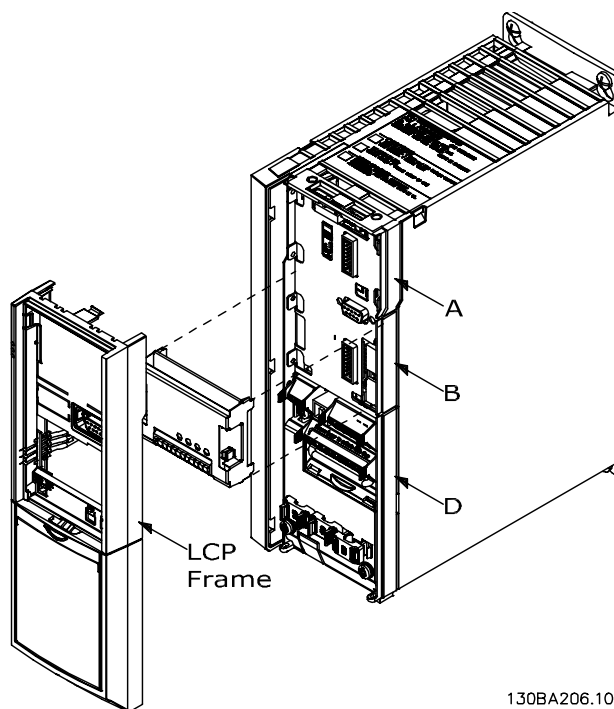

A	A-option slot
B	B-option slot
D	D-option slot

Illustration 4.2 How to Fit the Safety Option

1. Disconnect power to the frequency converter.
2. Remove the LCP, the terminal cover, and the LCP frame from the frequency converter.
3. Write down the serial number and order number of the safety option. Use this information in the commissioning process.
4. Fit the safety option in slot B.

4.5 Electrical Installation

To ensure that the installation and wiring are EMC-compliant, read the instructions in the following manuals:

- VLT® AutomationDrive FC 301/FC 302 Operating Instructions.
- VLT® PROFINET MCA 120 Installation Guide.

4.5.1 Cabling Requirements

CAUTION

If a short circuit occurs, it is no longer possible to switch off the frequency converter with terminal 37.

NOTICE

All signals to safety option must be PELV supplied and comply with EN IEC 60204.

Follow these guidelines to ensure a proper wiring:

- Use appropriate wiring to prevent short circuits to a supply line or between the inputs.
- Use separate multi-core cable for supply voltage to avoid short circuits between the cable from the output (S37) and the 24 V DC supply line.
- Connect screens at both ends to the grounded enclosures through a good electrical connection and through a large surface area.
- Connect cable screens as close as possible to the cabinet cable entry.
- If possible, intermediate terminals should not interrupt cable screens.
- Retain cable screens for both power cables and data cables using the appropriate EMC clamps. Ensure that the screen connection for control cables has a low induction.

NOTICE

If short circuits and cross circuits can be expected with safety-related signals, and if they are not detected by upstream devices, protected cable installation is required as per EN ISO 13849-2.

4.5.2 Connector Pin Assignment

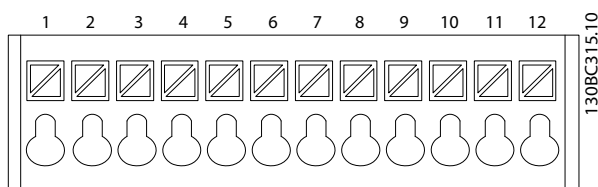

Pin	Name	Description
1	DI1 A	Digital Input 1 A channel
2	GND	Ground
3	DI1 B	Digital Input 1 B channel
5	DI2 A	Digital Input 2 A channel
6	GND	Ground
8	DI2 B	Digital Input 2 B channel
9	GND	Ground
10	24 V	Power output
11	GND	Ground
12	S37	Safe output

Illustration 4.3 Connector Pin Assignment, MCB 152

4.5.3 Wiring Procedures

1. Remove the jumper wire between control terminals 37 and 12/13 (24 V).

NOTICE

Cutting or breaking the jumper is not sufficient to avoid short circuiting.

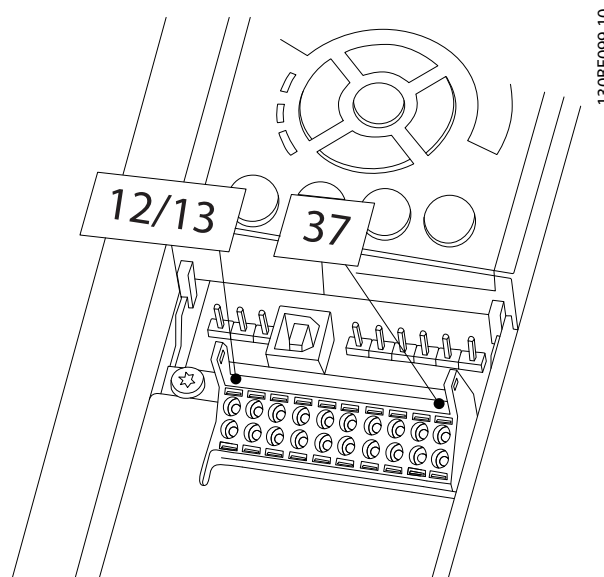
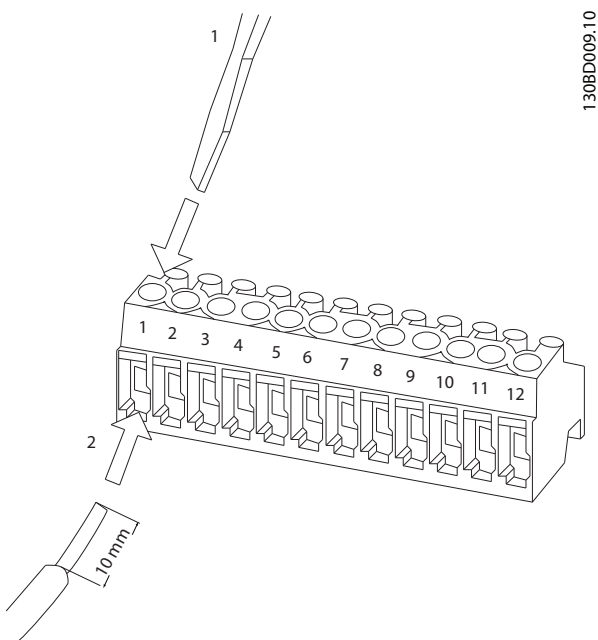

Illustration 4.4 Jumper between Terminals 12/13 (24 V) and 37

2. Connect the safe output S37 on the safety option to terminal 37 on the control card (maximum length of this wire is 10 cm).



130BD009.10

Illustration 4.5 Connecting Control Wiring

3. Connect the control cables to the safety option and relieve the cable by the enclosed cable strips. Follow the guidelines in *chapter 4.5.1 Cabling Requirements*.

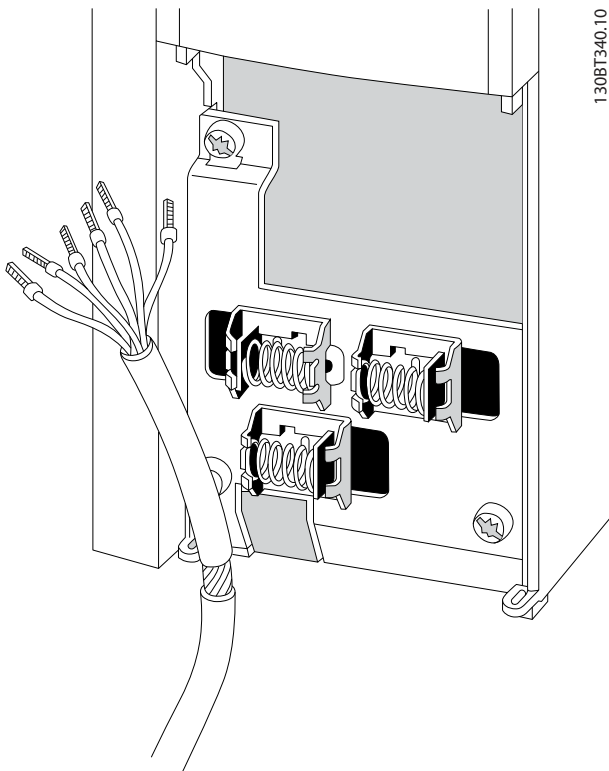

130BT340.10

Illustration 4.6 Connecting Screened Wire

4. Remove the knock-out in the extended LCP frame, so that the option fits under the extended LCP frame.
5. Fit the extended LCP frame and terminal cover.
6. Fit the LCP or blind cover in the extended LCP frame.
7. Connect power to the frequency converter. At the first power-up, the safety option is in blank initial state. In the blank initial state, all safety parameters have the default values.

4

4.6 Installation Checklist

Before completing installation of the unit, inspect the entire installation as described in *VLT® AutomationDrive FC 301/FC 302 Operating Instructions*.

5 Commissioning

5.1 Before Commissioning

When commissioning/recommissioning:

- Secure the site in accordance with regulations (barrier, warnings, signs, etc.). Only qualified personnel is allowed to commission/recommission the system.
- Refer to the guidelines, information and specifications stated in the operating instructions of the relevant control system.
- Make sure that no personal injury and/or material damage can occur, even if the machine moves unintentionally.

Refer to *VLT® AutomationDrive FC 301/FC 302 Operating Instructions* for further information on the frequency converter.

Refer to *MCT 10 Set-up Software Operating Instructions* for further information on the Safe Plug-in.

5.2 Commissioning Requirements

The following components are required to perform the necessary steps for the commissioning of the safety option.

- MCT 10 Set-up Software (licensed version).
- A connection between the PC and the control card of the frequency converter.

Follow these general steps to perform the commissioning:

1. Configure the safety option in MCT 10 Set-up Software with the Safe plug-in. Configure only the safety functions that are connected to the safety option inputs.
2. Ensure that the serial number and the ordering number of the safety option on the frequency converter match the serial number in *15-63 Option Serial No* and the ordering number in *15-62 Option Ordering No*. Use array index 1 to see the number related to the safety option.
3. Ensure that the frequency converter is ready for commissioning (see *VLT® AutomationDrive FC 301/FC 302 Operating Instructions*)

NOTICE

If RS485 is used, set the protocol for serial communication to [1] FCMC in 8-30 Protocol (only accessible through the LCP). Ensure the correct settings of the communication parameters (baud rate, etc.).

5.3 Commissioning Procedure

5.3.1 Power-up/Self-test

When the power is applied, the frequency converter automatically detects the safety option. During the start-up, the safety option performs a self-test. If the safety option is in blank initial state, the message *Safe Opt. initialized - SO RESET requested* or *SO in Self-test* appears on the LCP. After the self-test, the LEDs light up according to the device status.

5.3.2 Commissioning in Online Mode

This section describes the example of the safety option commissioning procedure with MCT 10 Set-up Software. In this example:

- A VLT® PROFINET MCA 120 option is installed in the frequency converter and PROFIsafe communication is required for the application.

To commission the safety option:

1. In MCT 10 Set-up Software, establish a connection between the PC and the frequency converter.
2. In MCT 10 Set-up Software, select the *Safe* plug-in.



3. Select *PROFIsafe* in *Safe input*⇒*Safe Fieldbus*⇒*Telegram Selection*, and enter the destination address in the *Destination Address* field.



4. Select the appropriate safe function for digital input 1 in the *DI1* group.

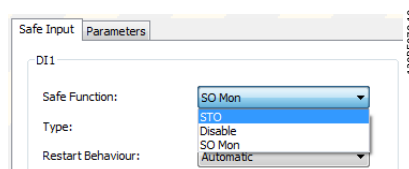

5. Make other application specific settings.
6. In the *Safe* plug-in, click *Write to Drive*.
7. If the safety option is in blank initial state, it prompts the user to change the password.
 - 7a In the *New password* dialog box, enter the current password (which is the default password - 12345678) and the new password and click *OK*.

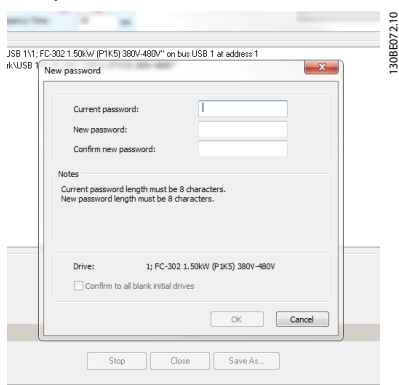

- 7b The *Safe* plug-in shows the confirmation message. Click *OK*.

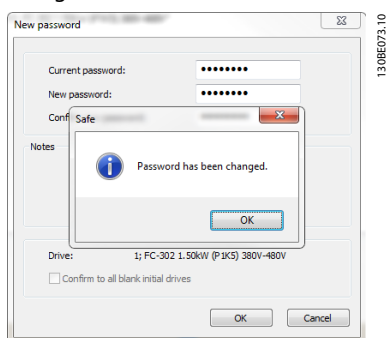

8. In the *Confirm password* dialog box, enter the new safety option password and click *OK*.

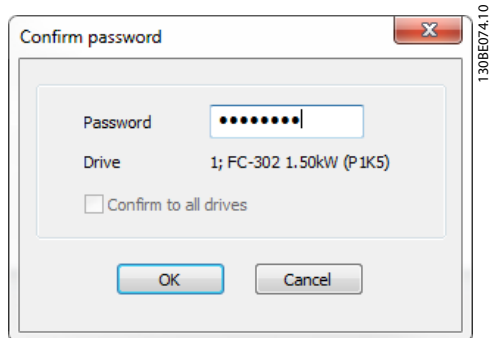

9. In the *Configuration Approval* dialog box, verify the safety configuration and click *Approve* to start writing the safety parameters.

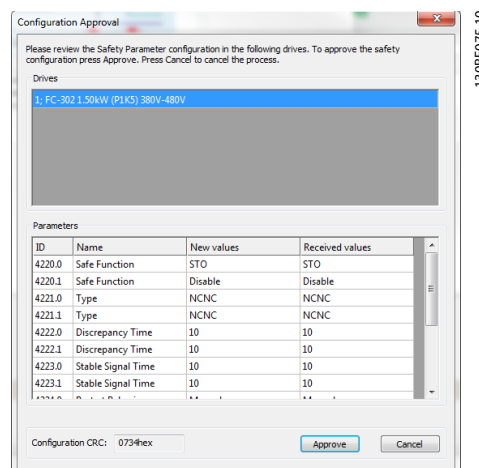

Click *Cancel* to abort the customisation process and revert the previous safety option state. The MCT 10 Set-up Software opens the *Writing Safety Parameters* dialog box.

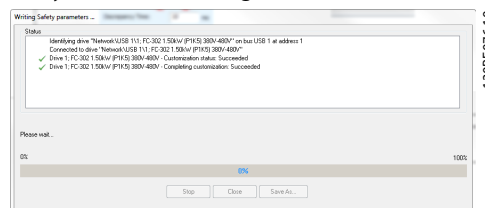

10. When the progress bar reaches 100%, the safety parameters are written.
11. The MCT 10 Set-up Software generates and opens the commissioning report.

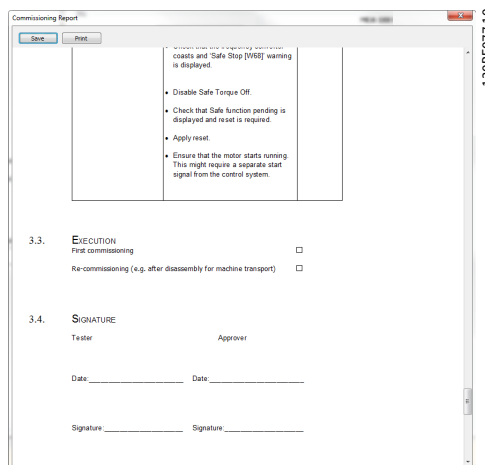

12. Save and print the commissioning report. The report is required for future maintenance.
13. Close the commissioning report dialogue box and the *Writing Safety Parameters* dialog box.
14. The safety option customisation is now complete. A reset may be required depending on the safety option configuration. Up to 10 may elapse before the safety option is ready for operation.

NOTICE

If any errors occur while changing the password or after the approval step, the *Safe* plug-in shows a notification with the error description

NOTICE

If STO is inactive (the frequency converter is operational) when a user starts the customisation process, the *Safe* plug-in shows the *Confirmation Required* dialog box. This dialog box prompts the user to confirm that STO is activated during the commissioning.

5.4 Commissioning Test

EN IEC 61508, EN IEC 62061 and EN ISO 13849 require that the final assembler of the machine validates the operation of the safety function with a commissioning test. The tests for the configured safety functions are described in the commissioning report generated by the MCT 10 Safe Plug-in. The commissioning test must be performed in the following cases:

- At initial start-up of the safety option.
- After any changes related to the safety function (wiring, components, parameter settings, etc.)
- After any maintenance work related to the safety function.

The commissioning test for systems with safety functions is focused on:

- Validating the functionality of safety monitoring and stop functions configured in the frequency converter system.
- Correct selection of the safety option parameter values.
- Examining the response of specific monitoring functions to the explicit input of values outside tolerance limits.

Perform the commissioning test on the basis of the risk analysis. Adhere all applicable standards and regulations.

5.4.1 Preconditions for Performing the Commissioning Test

Ensure that the following preconditions are met:

- The frequency converter is wired properly. For information about wiring, see *chapter 4.5.3 Wiring Procedures*.
- All safety equipment such as protective monitoring devices, light barriers or emergency stop switches are connected and ready for operation.

- All motor parameters and command parameters are set correctly in the frequency converter.

Performing the commissioning test:

1. Use MCT 10 Set-up Software to generate the commissioning test report.
2. Follow the test sequence in the report to ensure proper functioning of the safety option.
3. Document each individual step of the test.
4. Note the checksum of the safety option parameters in the records.
5. Do not release the system unless it has successfully passed all individual steps of the test.
6. Restart the frequency converter and check that the motor runs normally.

5.5 Operation

5.5.1 Safety Instructions

⚠ WARNING

UNINTENDED BEHAVIOUR

Numerous stored data or settings determine the behaviour of the frequency converter system. Unsuitable settings or data may trigger unexpected movements or responses to signals and disable monitoring functions.

- Do NOT operate the frequency converter system with unknown settings or data.
- Verify that the stored data and settings are correct.
- When commissioning, carefully run tests for all operating states and potential error situations.
- Verify the functions after replacing the product and also after changing the settings or data.
- Only start the system if there are no persons or obstructions in the hazardous area.

Failure to follow these instructions can result in death, serious injury or equipment damage.

Prerequisites for normal operation:

- Commissioning is complete.
- The safety option contains the configuration data.
- The safety functions have been tested.
- LED1, LED2, LED3 and LED4 are lit up according to the configuration.

During operation:

- The safety option monitors any pulse changes at its safe inputs.
- The safety option executes safety functions according to the configuration.

5.6 Commissioning Set-up Examples

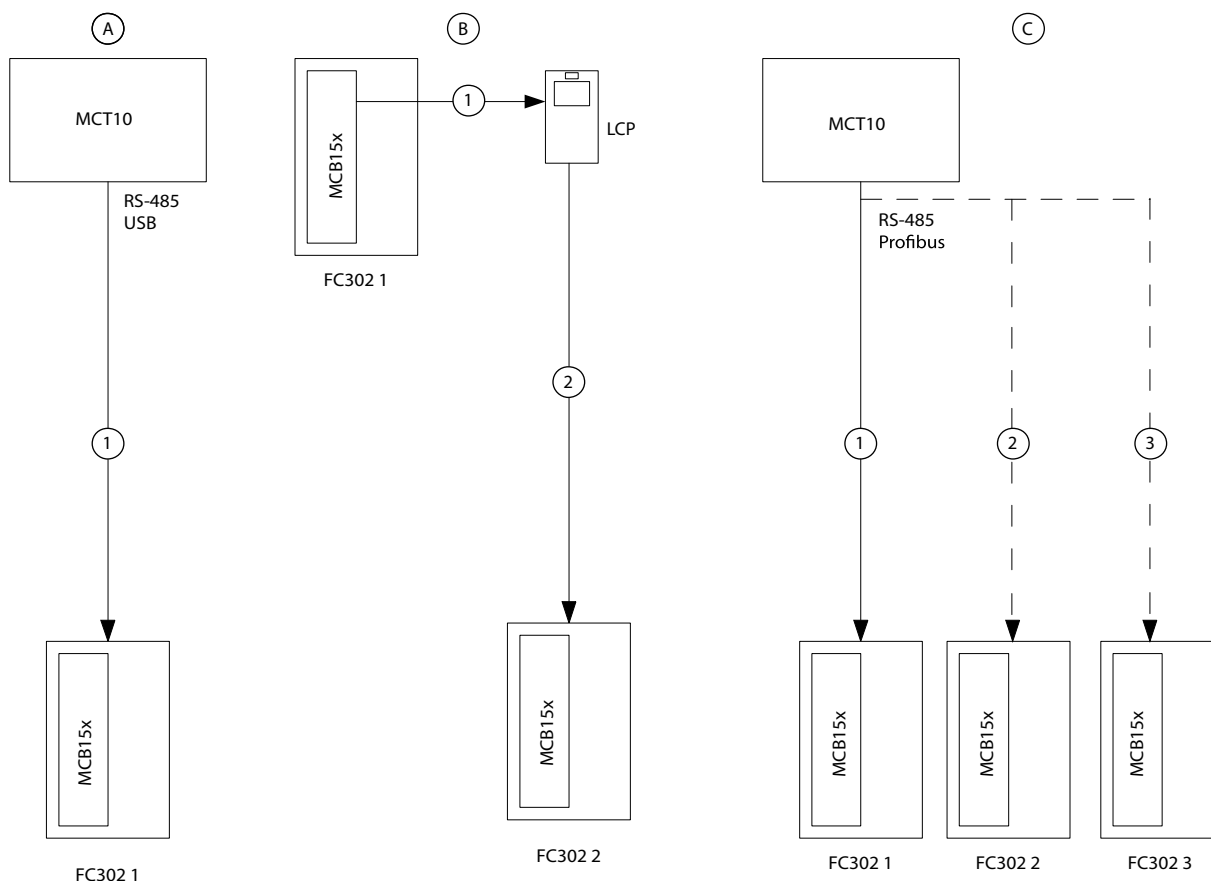

130BC327.10

A	Commission is done between MCT 10 Set-up Software and the frequency converter.
B	Safety parameters are copied from one frequency converter to another using <i>LCP Copy</i> .
C	Safety options configured in a network using MCT 10 Set-up Software.

Illustration 5.1 Commissioning Set-up Examples

6 Configuring the Safety Option

6.1 PROFIsafe Configuration

6.1.1 Telegram Configuration

Use parameter *42-60 Telegram Selection* to select the safe fieldbus type and telegram standard that the safety option uses to communicate with the safe PLC. Safety Option MCB 152 supports PROFIsafe standard telegram 30. If the parameter is set to *[0] None*, the safe fieldbus is disabled. The following tables describe the *PROFIdrive on PROFIsafe standard telegram 30* bits. In a PLC program, address the safety functions using bits and not bytes.

Byte 0 is PROFIdrive on PROFIsafe specific and byte 1 is vendor-specific.

PROFIsafe control word (CTW)

Byte	Bit ¹⁾	Name
Byte 0	0	STO
Byte 0	1-6	Not supported
Byte 0	7	INTERNAL_EVENT_ACK
Byte 1	0-7	Not supported

Table 6.1 PROFIsafe Control Word (CTW)

1) Bits that are not supported are set to 0.

Bit 0, STO

Bit 00 = 0, Safe Torque Off (zero-active).

Bit 00 = 1, No Safe Torque Off.

Bit 7, INTERNAL_EVENT_ACK

When this bit changes its value from 1 to 0, the safety option gives an acknowledgement to the safety fault buffer. Fault entries in the safety fault buffer are shifted to the last acknowledged fault situation. Faults which are still present or not acknowledgeable appear again in the actual fault situation. For more information, refer to the PROFIdrive profile description at www.profibus.com.

PROFIsafe status word (STW)

Byte	Bit ¹⁾	Name
Byte 0	0	POWER_REMOVED
Byte 0	1-6	Not supported
Byte 0	7	INTERNAL_EVENT
Byte 1	0	Status DI1
Byte 1	1	Status DI2
Byte 1	2-7	Not supported

Table 6.2 PROFIsafe Status Word (STW)

1) Bits that are not supported are set to 0.

Byte 0, Bit 0, POWER_REMOVED

Bit 00 = 0, Safe Torque Off inactive.

Bit 00 = 1, Safe Torque Off active.

Byte 0, Bit 7, INTERNAL_EVENT

Bit 07 = 0, No safety fault.

Bit 07 = 1, Safety fault present.

Byte 1, Bit 0, Status DI1

Bit 00 = 0, the digital input is active.

Bit 00 = 1, the digital input is inactive.

Byte 1, Bit 1, Status DI2

Bit 01 = 0, the digital input is active.

Bit 01 = 1, the digital input is inactive.

To show the hex values of PROFIsafe status word and PROFIsafe control word on the LCP, use *42-83 Safe Status Word* and *42-82 Safe Control Word*. The hex values are used for debugging purpose or for transferring the safe control information to a non-safe control environment.

Safe fieldbus address

Set the safe fieldbus address in parameter *42-61 Destination Address*. For PROFIsafe, the valid values are from 1 to 65535. This address must be unique in the network where PROFIsafe operates. The address should match the address specified in the PLC configuration.

6.1.2 Safety Functions Configuration

Use the MCT 10 Set-up Software Safe plug-in to configure the safety functions and to enable the PROFIsafe communication. For more information, refer to *chapter 5.3.2 Commissioning in Online Mode*.

NOTICE

Always perform the required commissioning test. The commissioning test report is automatically generated via the Safe Plug-in in MCT 10 Set-up Software after writing the parameters to the safety option.

6.1.3 Password Protection

Use a password to protect the system configuration. A password must be entered only when changing safety option parameters (writing to option).

The default password is 12345678.

Change the safety option default password before downloading the parameter values of a safety option with factory settings.

NOTICE

Any misuse of the password may lead to safety issues.

No password is required to access the commissioning parameters of the safety option. The password is required when writing the parameters to the option via the *Write to Drive* feature.

If a user forgets the password, the safety option can be reset using MCT 10. To reset the safety option:

- In MCT 10 Set-up Software, click *Administration*.
- In the *Reset* tab, select *Yes, I want to reset Safety Option Configuration in the drive*, enter the default password and click *Reset*.

The password must consist of 8 characters and is case-sensitive. Alphanumeric characters and symbols are valid for the password.

Use the *Change Password* menu item to change the safety option parameter password.

6.2 Status over Fieldbus

The safety option status can be retrieved as part of the status word. Its behaviour changes based on the selected control word profile.

Select [91] *Safe Opt. Reset. req* and [90] *Safe Function active* in 8-13 *Configurable Status Word STW* to achieve the following:

- Indicate that a reset of the safety option is required. These signals are also available as DO outputs.
- Indicate that a safety function is active.

6.2.1 Safety Option Reset via Control Word

To reset the safety option using the control word, select [3] *Safe Option Reset* in 8-14 *Configurable Control Word CTW*. This option is available only in bits 12-15 of 8-14 *Configurable Control Word CTW*.

6.2.2 Safety Option Status

42-80 *Safe Option Status* indicates the actual status (active safe function, any requests and the error number) of the safety option and is accessible as a read only parameter from any interface and is configurable as a read process data for a specific fieldbus.

NOTICE

42-80 *Safe Option Status* shows only the active safety function.

Bit	Description
0	Normal_up
1	PUST
2	STO active
3-6	Not applicable
7	Reserved for further SF
8	Safe output status
9	For internal use only. Safety option uses this bit to reset all safety parameters to default values.
10	Safe fieldbus acknowledge request
11	Int_fail
12	Reset required
13	Pending fail safe state
14	Ext_fail
15	Safe function pending
16	General reset
17	Customisation_confirmed
18	Customisation_aborted
19	Customisation_requested
20	Not applicable
21	PUST warning
22	DI_1_offline_warning
23	DI_2_offline_warning
24	Error code
25	Error code
26	Error code
27	Error code
28	Error code
29	Error code
30	Error code
31	Error code

Table 6.3 Status Bits for Safety Option Status

Bit 00, Safety function deactive/active

Bit 00 = 0, Safety function, fail safe reaction is active or pending or warning is active
 Bit 00 = 1, Normal operation.

Bit 01, Power up self test

Bit 01 = 1, Safety option is in PUST state.

Bit 02, Safe Torque Off

Bit 02 = 0, Safe Torque Off is not active.
 Bit 02 = 1, Safe Torque Off is active.

Bit 07

Reserved for future safety functions.

Bit 08

Bit 08 = 0, Safe output at 24 V.
 Bit 08 = 1, Safe output at 0 V.

Bit 10

Bit 10 = 0, No operator acknowledgement requested.
 Bit 10 = 1, Operator acknowledgement from safe PLC requested.

Bit 11, Internal error

Bit 11 = 0, No internal error is active.

Bit 11 = 1, An internal error is active.

Bit 12, Reset

Bit 12 = 0, No safety option reset is required.

Bit 12 = 1, A safety option reset is required .

Bit 13, Pending fail safe state

Bit 13 = 0, No pending fail safe state.

Bit 13 = 1, The safety option is in this state at each power-up.

Bit 14, External error

Bit 14 = 0, No external error is active.

Bit 14 = 1, external error is active.

Bit 15, Safe function pending

Bit 15 = 0, No safe function is pending.

Bit 15 = 1, A safe function is pending.

Bit 16, General reset

Bit 16 = 0, No change in state

Bit 16 = 1, A general reset is done.

Bit 17, Customisation confirmed

Bit 17 = 0, No change in state.

Bit 17 = 1, Customisation confirmed by user.

Bit 18, Customisation aborted

Bit 18 = 0, No change in state.

Bit 18 = 1, Customisation aborted by user.

Bit 19, Customisation requested

Bit 19 = 0, No change in state.

Bit 19 = 1, Customisation is requested by user.

Bit 20, Suspension of speed monitoring

Bit 20 = 0, No change in state.

Bit 20 = 1, Suspension of speed monitoring – see error code.

Bit 21, Power up self test warning

Bit 21 = 0, No change in state

Bit 21 = 1, A power up self test warning is issued.

Bit 22, Digital input 1 offline test warning

Bit 22 = 0, No change in state.

Bit 22 = 1, Digital input 1 offline test warning

Bit 23, Digital input 2 offline test warning

Bit 23 = 0, No change in state.

Bit 23 = 1, Digital input 2 offline test warning.

Bit 24-31

These bit indicate a reason for internal or external errors, for more information, see the error codes.

42-81 *Safe Option Status 2* indicates which digital input of the safety option is activated, in pending state or in blank initial state.

Bit	Description	State
0	DI1 safety status	00 - Inactive
1		01 - Active 10 - Pending
2	DI2 safety status	00 - Inactive
3		01 - Active 10 - Pending
4	Blank initial state	0 (inactive)/1 (active)
5	Safe fieldbus support	000 - No safe fieldbus supported 001 - PROFIsafe supported.
6		
7		
8	Safe function status on safe fieldbus	0 - Deactivated 1 - Activated
9-31	Not used	-

Table 6.4 Status Bits for Safety Option Status 2

6.3 Reset Function

When the safety function is activated, reset the safety option. Depending on the configuration, the following sources can reset the safety option:

- The *Reset* key on the LCP or the frequency converter's digital input.
- The digital input on the safety option (DI2_A).
- The reset signal via the safe fieldbus.
- The automatic reset function.

Parameter *42-24 Restart Behaviour* determines whether the safety option restarts automatically, or waits for a manual reset after the safety function was activated:

- Manual reset behaviour - when the safety function is activated, the safety option requires a reset from a reset source before it can run again.
- Automatic reset behaviour - when the safety function is activated, the safety option can run again as soon as the condition that triggered the safety function ceases. This behaviour is only valid for the digital input where this reset behaviour is defined. For instance, in case of an external error, a manual reset from the reset source is required regardless of the setting in *42-24 Restart Behaviour*.

For more information, read the description of *42-31 Reset Source* and its options in *chapter 7.1 Parameter List*.

6.3.1 Reset Input (DI2)

If manual reset is configured, wire the DI2A reset input terminal to a 24 V DC via an NO switch. The manual reset can also be used to reset external errors detected by the safety option.

6.4 Configuring PROFIsafe with Siemens Step 7

This section explains how to configure PROFIsafe communication between Safety Option MCB152 and Siemens device in Siemens STEP 7 environment.

6.4.1 Configure the Hardware

Configure the PROFINET communication with the F-PLC using the *VLT®PROFINET MCA 120 Installation Guide*.

To add the Danfoss device to the PROFIsafe connection in **STEP 7**:

1. In the panel on the right side, select *PROFINET IO* ⇒ *Additional Field Devices* ⇒ *Drives* ⇒ *VLT FC Series* ⇒ *Danfoss FC PN*.

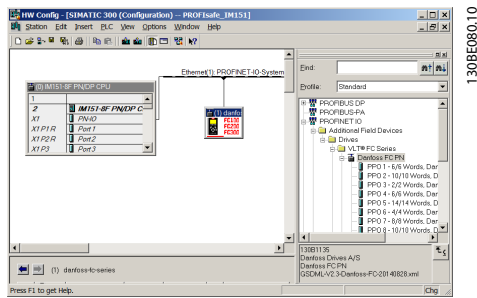

2. Drag the *Danfoss FC PN* module and drop it onto the PROFINET connection. **STEP 7** may require to enter a password for this operation.
3. In the *Password for Safety Program* dialogue box, enter the appropriate password.
4. To edit the Danfoss device properties, double-click the device.
5. In the *Device name* field, enter the same name as shown in *12-08 Host Name*.

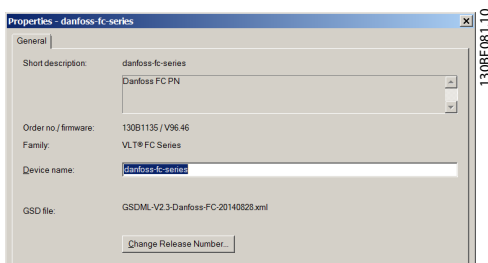

6. Select the module and add the following I/O protocol: *PROFIsafe 30 -6/6 Bytes, Standard Telegram 30*.

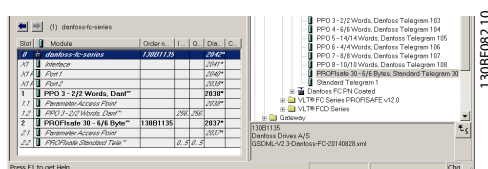

7. To edit the PROFIsafe settings, double-click *PROFIsafe Standard Telegram* at the bottom of the *HW Config* dialogue box, d.

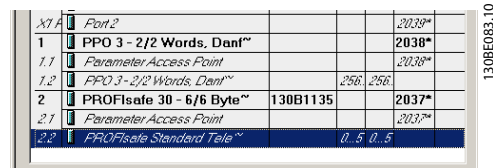

8. Select the *PROFIsafe* tab in the *Properties* dialogue box, .

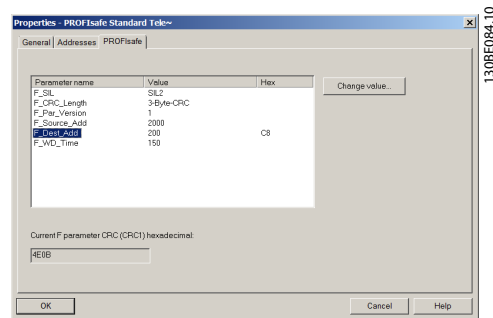

9. Edit the required settings.

The following 3 parameters can be changed, but normally it is only necessary to change the *F_Dest_Add* parameter:

- *F_Source_Add* - the PROFIsafe address of the PROFIsafe master.
- *F_Dest_Add* - the destination address of Safety Option MCB 152. This address must be the same as set in MCT-10 Set-up Software, *42-61 Destination Address*.
- *F_WD_Time* - the watchdog time for the PROFIsafe connection.

Watchdog time

The watchdog time setting depends on the speed of the PROFINET connection and the number of devices.

Valid range: 67-65535 ms.

Default value: 150 ms.

If the safety option does not receive a new valid PROFIsafe telegram within this time, the safety option enters the safe state. The watchdog time is configured to a value that is long enough to avoid false alarms and short enough to detect errors in communication. The formula for calculating the minimum watchdog time:

$$F_WD_Time = 2 * BT + HAT + DAT$$

- BT = Bus cycle time.
- HAT=Host acknowledgement time.
- DAT=Device acknowledgement time.

Use the watchdog time to calculate the safety function response time (SFRT) for the system. For more information, see the PROFIsafe profile description at www.profibus.com.

6.5 Configuring PROFI-safe with Siemens TIA Portal

This section explains how to configure the PROFI-safe fieldbus communication between Safety Option MCB 152 and a Siemens device with Siemens TIA Portal.

6.5.1 Configure the Hardware

Configure the PROFINET communication with the F-PLC using *VLT® PROFINET MCA 120 Installation Guide*.

1. In the *SIEMENS TIA* portal, select *Open the project view*. Double-click *Devices and Networks*. The *Hardware Configuration* dialogue box opens.
2. Select the Danfoss device in the network view and drag it into the work space:

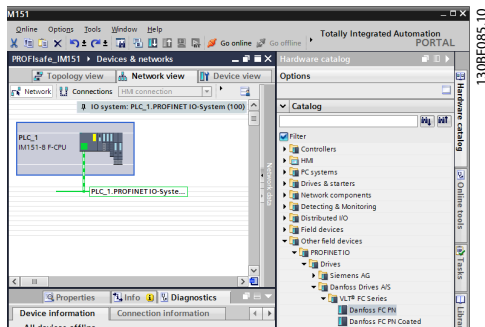

3. The project view shows the F-PLC and the Danfoss Device:

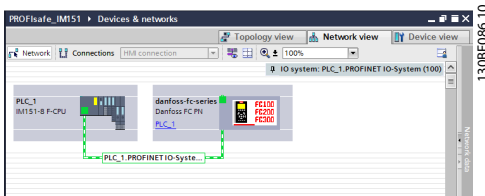

4. Assign the name to the Danfoss device. The name must be the same as shown in *12-08 Host Name*:

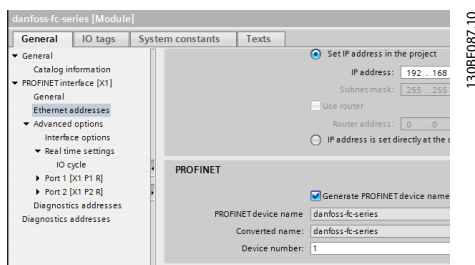

5. Select the following I/O protocol: *PROFI-safe 6/6 Bytes, Standard Telegram 30*.

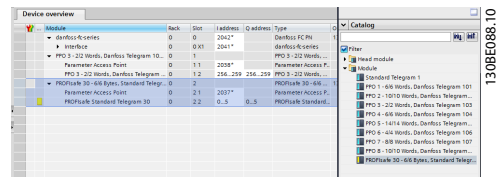

6. Edit the required PROFI-safe settings under *Properties* tab.

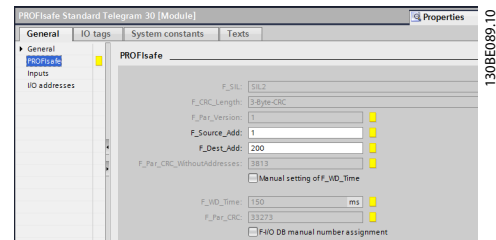

The following 3 parameters can be changed, but normally it is only necessary to change the *F_Dest_Add* parameter:

- *F_Source_Add* - the PROFI-safe address of the PROFI-safe master.
- *F_Dest_Add* - the destination address of Safety Option MCB152. This address must be the same as set in MCT-10 Set-up Software, *42-61 Destination Address*.
- *F_WD_Time* - the watchdog time for the PROFI-safe connection. This setting depends on the speed of the PROFINET connection and the number of followers.

6.5.2 Programming Safety Functions with Siemens Step7 and TIA Portal

Refer to the Siemens documentation for more information on distributed safety. Refer to the following documentation for information on how to use safety inputs and outputs for passivation and reintegration.

- *Industrial Software SIMATIC Safety - Configuring and Programming*. Programming and Operating Manual.
- *Fail-safe Controllers SIMATIC Safety Integrated*. Emergency Stop with Acknowledgement in Category 4 according to EN 954-1.
- *Fail-safe Controllers SIMATIC Safety Integrated*. Passivation and Reintegration of F-I/O considering as example the ET 205S.

7 Parameter Set-up

This section describes the safety option parameters.

Use MCT 10 Set-up Software to configure the safety functions supported in Safety Option MCB 152.

Safety parameters have the following properties:

- The safety option stores 2 separate copies of the safety parameters.
- During start-up, a cyclic redundancy check (CRC) sum over the safety parameters is calculated and checked. The safety option stores parameters in the non-volatile memory. To see the CRC value on the LCP, add *42-35 S-CRC Value* to the LCP small display line.

A reset of the safety parameters to the blank initial state can be executed via MCT 10 Set-up Software.

7.1 Parameter List

All safety parameters, except *42-90 Restart Safe Option* can only be read from the LCP (but not changed). Use the MCT 10 Set-up Software Safe plug-in to change the parameter values.

Refer to *VLT® AutomationDrive FC 302 Programming Guide* for general information about usage of conversion index and data type.

42-2* Safe Input

Parameter	Options/Valid range	Default value	Description	Conversion index	Data type
42-20 Safe Function	[0] STO [5] Disable [8] SO Mon	[5] Disable	Select the safety function that the safety option activates when the safe input is active. [0] STO - the safety option activates STO. [5] Disable - the safety option ignores the current safe input. [8] SO Mon - the safety option monitors all activity on the current safe input, but does not activate safety functions. The safety option transmits the information to the PLC and the PLC handles the safety logic. This parameter is an array with 2 elements. Element 0 contains DI1 settings and element 1 - DI2 settings.	-	u_int8
42-21 Type	[0] NCNC [1] Antivalent [2] NC	[0] NCNC	Select the safe input type. <ul style="list-style-type: none"> [0] NCNC: A digital input is active when there is 0 V at both channels of the input. [1] Antivalent: A digital input is active only when there is 0 V at channel A and 24 V at channel B. [2] NC: The functionality is similar to NCNC. For more information, see <i>chapter 3.2.1 Permitted Sensor Types on Digital Inputs</i> .	-	u_int8
42-22 Discrepancy Time	0 - 5000 ms	10 ms	Enter the maximum time in ms allowed for differences between input channels. This parameter helps to prevent errors caused by temporary discrepancy.	-3	u_int16
42-23 Stable Signal Time	0 - 5000 ms	10 ms	Enter the stable signal time in ms. The stable signal time is the period where the Safety Option MCB 152 suppresses temporary signal changes at its safety inputs. This functionality prevents the Safety Option MCB 152 from reacting to short test pulses from external modules or sensors.	-3	u_int16
42-24 Restart Behaviour	[0] Manual [1] Automatic	[0] Manual	Select whether the safety option restarts automatically or waits for a manual reset after the safety function was activated via a digital input. [0] Manual - when the safety function is activated via a safe input, the safety option requires a reset from a reset source before it can run again. [1] Automatic - when the safety function is activated, the safety option can run again as soon as the condition that triggered the safety function ceases.	-	u_int8

Table 7.1 42-2* Safe Input

42-3* General

Parameter	Options/Valid range	Default value	Description	Conversion index	Data type
42-30 External Failure Reaction	[0] STO	[0] STO	Select a safety function that is executed in case of an external error.	-	u_int8
42-31 Reset Source	[0] Drive Reset [1] Drive Safe Reset [2] Safe Option DI2_A	[0] Drive Reset	<p>Select the source that triggers the safety option reset.</p> <p><i>[0] Drive Reset</i> - the reset sources are:</p> <ul style="list-style-type: none"> The frequency converter Reset key on the LCP. The frequency converter digital input. The reset signal via a fieldbus. <p>If there is an active alarm on the frequency converter, the first reset signal resets the frequency converter, and the second signal resets the safety option.</p> <p><i>[1] Drive Safe Reset</i> - the reset sources are:</p> <ul style="list-style-type: none"> The frequency converter's digital input. Select option <i>[100] Safe Option Reset</i> on 1 of the digital inputs for this source type to work. The reset signal via a fieldbus. For the fieldbus reset to work, set <i>8-14 Configurable Control Word CTW</i> to <i>[3] Safe Option Reset</i>. <p>The reset signal resets only the safety option.</p> <p><i>[2] Safe Option DI2_A</i> - the reset source is the digital input DI2_A on the safety option. The reset signal resets only the safety option.</p>	-	u_int8
42-33 Parameter Set Name	Visible String, length: 8	SafeSet1	Enter the name of the safety parameter set (8 characters). Use this parameter to identify the safety configurations.	-	Visible-String

Table 7.2 42-3* General

42-6* Safe Fieldbus

Parameter	Options/Valid range	Default value	Description	Conversion index	Data type
42-60 Telegram Selection	[0] None [1] PROFI-safe Std. Tel. 30	[0] None	Select the safe fieldbus type and the telegram standard for the Safety Option MCB 152. [0] None - the safe fieldbus communication is disabled. [1] PROFI-safe Std. Tel. 30 - the PROFI-safe communication is enabled. The telegram standard is PROFI-safe Std. Tel. 30. For more information, see chapter 6.1.1 Telegram Configuration. If fieldbus communication is enabled, and if the reset signal comes via the fieldbus, this parameter also defines whether the frequency converter is also reset or only the safety option is reset.	-	u_int8
42-61 Destination Address	1-65535	1	Enter the safe fieldbus destination address within the safe network. This address must be unique in the network where PROFI-safe operates. The address should match the address specified in the PLC software.	-	u_int16

Table 7.3 42-6* Safe Fieldbus

42-8* Status

Parameter	Options/Valid range	Default value	Description	Conversion index	Data type
42-80 Safe Option Status	0 - 0xFFFFFFFF	0	Shows the status word of the Safety Option MCB 152 as a hexadecimal value. For more information, see <i>chapter 6.2 Status over Fieldbus</i> .	0	u_int32
42-81 Safe Option Status 2	0 - 0x7FFFFFFF	0	Shows the status 2 word of the Safety Option MCB 152 as a hexadecimal value. For more information, see <i>chapter 6.2 Status over Fieldbus</i> .	0	u_int32
42-82 Safe Control Word	0 - 0xFFFFFFFF	0	Shows the safe control word as a hexadecimal value.	-	u_int32
42-83 Safe Status Word	0 - 0xFFFFFFFF	0	Shows the safe status word as a hexadecimal value.	-	u_int32
42-85 Active Safe Func.	[0] STO [10] None	[10] None	Shows the currently active safety function. Use <i>0-20 Display Line 1.1 Small</i> to <i>0-22 Display Line 1.3 Small</i> to show the function on the LCP.	-	u_int8
42-86 Safe Option Info	Safe Option Messages, String Length 25	0	Shows information about the safety option. The LCP can show this parameter in the large display line. Can be selected in <i>0-23 Display Line 2 Large</i> and <i>0-24 Display Line 3 Large</i> .	0	Visible-String
42-88 Supported Customization File Version	0.00 - 99.99	2.00	Shows the maximum supported configuration file version (CfgFileVers): [0] – the maximum version supported by the safe system (frequency converter with the safety option). [1] – the maximum version supported by the safety option. [2] – the maximum version supported by the control card.	-2	u_int16
42-89 Customization File Version	0.00 - 99.99	2.00	Shows the currently used customisation file version.	-2	u_int16

Table 7.4 42-8* Status

42-9* Special

Parameter	Options/Valid range	Default value	Description	Conversion index	Data type
42-90 Restart Safe Option	[0] No [1] Yes	[0] No	Select [1] Yes to restart the Safety Option MCB 152 without power cycling the frequency converter. When the safe fieldbus is enabled the communication option is also restarted.	-	u_int8

Table 7.5 42-9* Special

NOTICE

Parameter group 600-** PROFIsafe is only visible in the MCT 10 Set-up Software.

600- PROFIsafe**

Parameter	Options/Valid range	Default value	Description	Conversion index	Data type
600-44 Fault Message Counter	0 - 65535	0	Shows the number of error messages shown since the last reset.	-	u_int16
600-52 Fault Situation Counter	0 - 1000	0	Shows the number of error situations shown since the last reset.	-	u_int16

Table 7.6 600-** PROFIsafe

0-6* Password

Parameter	Options/Valid range	Default value	Description	Conversion index	Data type
0-68 Safety Parameters Password	0 - 9999	300	Enter the password that protects the safety parameters.	-	u_int16
0-69 Password Protection of Safety Parameters	[0] Disabled [1] Enabled	[0] Disabled	Enable the password that protects the safety parameters.	-	u_int8

Table 7.7 0-6* Password

8 Application Examples

This chapter describes the *Safety Option MCB 152* application examples.

8.1 Connecting Safe Digital Inputs

This section contains examples of connecting the safe digital input according to EN ISO 13849-1 and EN IEC 62061. The examples apply in cases where all components are installed in a control cabinet.

Connecting a sensor, push button or limit switch

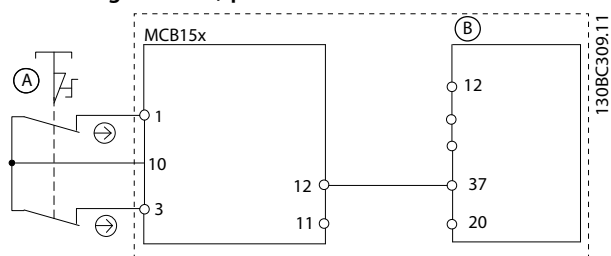

A	2-channel emergency stop switch
B	VLT® AutomationDrive FC 302

Illustration 8.1 Connecting a Sensor, for example 2-channel Emergency Stop Mushroom Push Button or Limit Switch

Connecting an electronic sensor

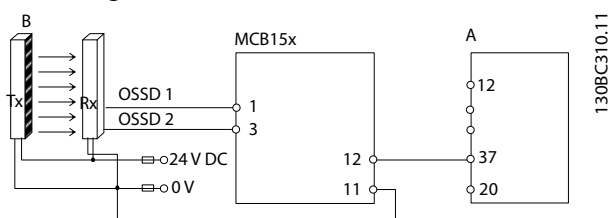

A	VLT® AutomationDrive FC 302
B	Light curtain.

Illustration 8.2 Connecting an Electronic Sensor, for example Safety Light Curtain

Connecting an antivalent sensor

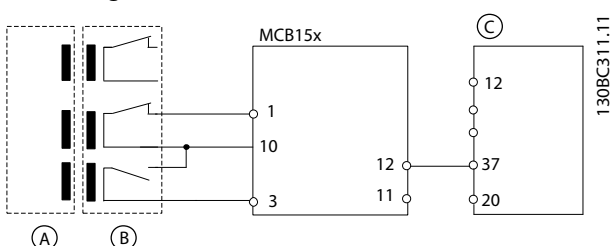

A	1-channel emergency stop switch
B	VLT® AutomationDrive FC 302

A	Actuator
B	Switch
C	VLT® AutomationDrive FC 302

Illustration 8.3 Connecting an Antivalent Sensor, for example Magnetic Switch

Connecting a digital output module

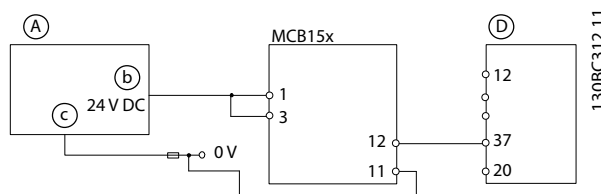

A	Safety PLC
b	Safety output
c	GND
D	VLT® AutomationDrive FC 302

Illustration 8.4 Connecting a Digital Output Module, for example Safety PLC. 1 Channel example.

NOTICE

The safety level is downgraded when inputs are used as 1 channel only.

Connecting a Sensor, for example 1-channel Emergency Stop Push Button

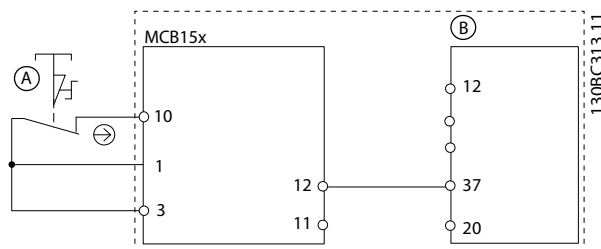

A	1-channel emergency stop switch
B	VLT® AutomationDrive FC 302

Illustration 8.5 Connecting a Sensor, for example 1-channel Emergency Stop Mushroom Push Button or Limit Switch

NOTICE

All equipment must be suitable for the selected safety category (PL or SIL).

NOTICE

Use of a 1-channel E-stop switch provides no input redundancy, and no ability for the safety option to monitor the input short circuits. 1-channel E-stop switches used with the safety option are suitable only for Category 2 applications. For information see EN ISO 13849-1.

When using a 1-channel E-stop, implement protective measures against failure modes that can result in an unsafe condition. An example of an unsafe condition could be the failure of the contact. Use a switch with positive opening operation to reduce the possibility of a failure of the switch to open.

A short circuit error results in the loss of switching function. This error can occur from a short circuit across the switch contacts, a short circuit across the wires between the switch and the safety option, or a short circuit to a secondary source of power. To reduce these risks, physically separate the wires from each other, and from other sources of power.

8

Example of multiple frequency converters in a daisy chain

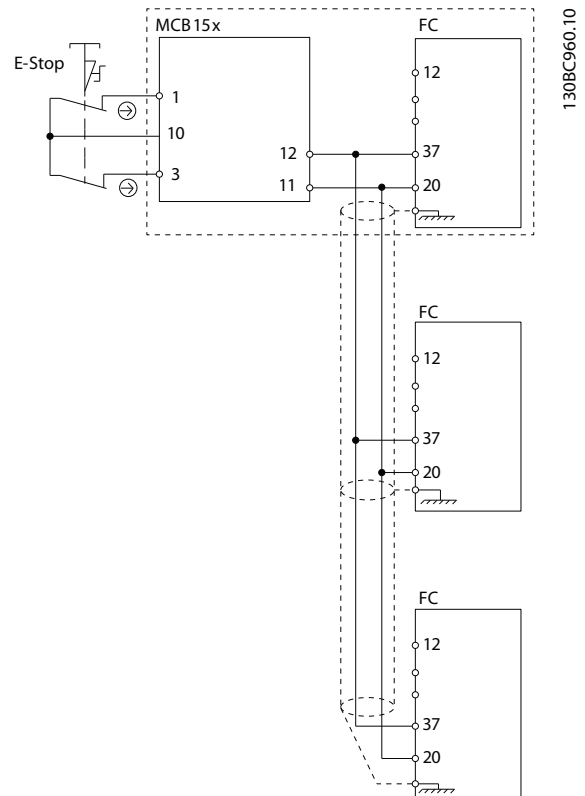

Illustration 8.6 Example of Multiple Frequency Converters in a Daisy Chain

NOTICE

Up to 3 frequency converters can be connected in a daisy chain. Total cable length must not exceed 30 m.

9 Maintenance, Diagnostics and Troubleshooting

9.1 Maintenance and Service

NOTICE

Updates to Firmware

Contact Danfoss to get a firmware update.

CAUTION

Firmware Modifications

Only Danfoss is authorised to change the firmware. If other parties make changes to the firmware, the warranty expires. Furthermore, Danfoss cannot be held liable for any consequences the changes may have on the functional safety.

CAUTION

Modifications to the Unit

Only Danfoss is allowed to make hardware modifications of the safety option. If other parties make changes to the unit, the warranty expires. Furthermore, Danfoss cannot be held liable for any consequences the changes may have on the functional safety.

CAUTION

Servicing

Once a year, check that the safety option functions properly to ensure the safety of the machine. Perform the check by testing the safety function and power cycling the options used in the safety chain.

9.1.1 Yearly Test

According to EN ISO 13849-1, EN IEC 62061 and EN IEC 61508, safety-relevant circuits of the safety option must be regularly tested to ensure correct functioning. Perform this test at least once every year. After the power supply has been connected, the safety option checks its circuits to switch-off the torque each time the STO function is selected. The safety option monitors the regular test interval of its safety-relevant circuits using a time module.

After 1 year in operation, the frequency converter displays a message that a yearly test must be performed. There are the following types of a yearly test:

- DI1 yearly test: Test only the activation of DI1. No power cycling required.
- DI2 yearly test: Test only the activation of DI2. No power cycling required.

- PUST yearly test: power cycle the frequency converter, or trigger an external error and press RESET.

9.2 Repair and Troubleshooting

WARNING

ELECTRICAL SHOCK HAZARD!

Always disconnect mains supply to the frequency converter before removing the safety option.

Only Danfoss is authorised to repair the safety option. A defect option must be shipped to Danfoss.

9.2.1 Removing the Safety Option

Before removing the safety option, save all parameters of the safety option and device settings using one of the following ways:

- Use MCT 10 Set-up Software, see *MCT 10 Set-up Software Operating Instructions*.
- Execute the LCP Copy operation by selecting [1] All to LCP in 0-50 LCP Copy. This operation duplicates the existing parameter settings.

NOTICE

If the safety option is not in the blank initial state when it is removed, the frequency converter trips with *Alarm 84*. To prevent this behaviour, set the option to blank initial state before removing it. This can be done by resetting the safety option with MCT 10 Set-up Software, for more information, see *chapter 6.1.3 Password Protection*.

NOTICE

If the frequency converter detects a change in the hardware configuration, the LCP shows *Alarm 67 Option Changed* after a power-up. This situation can occur after installing or removing an option, or if an option is defective.

NOTICE

If *14-89 Option Detection* is set to [0] *Protect Option Config.*, and the frequency converter detects a change in the configuration, the frequency converter trips with *Alarm 88 Option Detection* after start-up. This behaviour prevents any unintended parameter changes. To avoid alarm 88, set *14-89 Option Detection* to [1] *Enable Option Change*.

How to remove the safety option:

1. Disconnect all power supplies before removing the option.
2. Verify that no voltage is present.
3. Remove the safety option according to the instructions in *Installation* in VLT® *AutomationDrive FC 301/FC 302 Operating Instructions*.

NOTICE

If the removed safety option is installed in another frequency converter, the frequency converter issues a warning. The user can then select the safety configuration from either the frequency converter or from the safety option.

9.2.2 Replacing the Safety Option

⚠ WARNING**ELECTRICAL SHOCK HAZARD!**

Always disconnect mains supply to the frequency converter before removing the safety option.

When replacing the safety option, note the following:

- If the firmware version has changed, configured functions and stated parameters may no longer be supported or may have been modified. Adapt the configuration in the MCT 10 Set-up Software.

Use one of the following ways to program the safety option after the replacement:

- Reset the safety option to blank initial state as described in *MCT 10 Set-up Software Operating Instructions* and reprogram the safety option using MCT 10 Set-up Software as on the first commissioning as described in *chapter 5.1 Before Commissioning* and *chapter 5.3 Commissioning Procedure*.
- Use parameter mismatch functionality to use an existing parameter set with the new safety option.
- Copy the safe parameters using the graphical LCP, see *chapter 9.2.4 Copying Safe Parameter Configuration*.

NOTICE

Protect the safety parameter configuration from changes using the password protection. For example, the changes may occur when there is a parameter mismatch (see *chapter 9.2.3 Mismatch of Safety Option Parameters*), or when copying the parameters via LCP. 0-68 *Safety Parameters Password* and 0-69 *Password Protection of Safety Parameters* allow to configure the safety parameter password protection. This protection is different from the password that MCT 10 Set-up Software uses, for more information, see *chapter 7.1.1 Parameter List*.

NOTICE

If the safety option is replaced with a different safety option model, for example, if Safety Option MCB 152 is replaced with Safety Option MCB 150 or vice versa, the frequency converter trips with *Alarm 67, Option Change* or *Alarm 88, Option Detection*. For more information, see *chapter 9.2.1 Removing the Safety Option*.

9.2.3 Mismatch of Safety Option Parameters

At each power-up, the parameter mismatch functionality checks if the safety parameters in the frequency converter and the safety option are different. If there is a difference, for example after a replacement of the safety option, it is possible to select 1 of the valid detected safety parameter configurations using the *SO Param. Selection* form on the LCP:

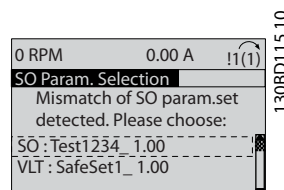

Illustration 9.1 SO Param. Selection Form.

After selecting 1 of the parameter sets, the set is written to the safety option. During this process the safety option saves a checksum along with the parameter set, which allows to identify the duplicated safety option parameters. The LCP messages guide through the parameter transfer. Follow the steps below when replacing the safety option, assuming that the safety parameters in the frequency converter have the correct values:

1. Select *VLT*.
2. If configured, enter the password for the safety option configuration that is being copied. See the

description of *0-68 Safety Parameters Password* and *0-69 Password Protection of Safety Parameters* in *chapter 7 Parameter Set-up*.

3. The LCP shows the *SO Data Confirmation* message.
4. Press *OK* to overwrite the safety parameters in the safety option.
5. Depending on the actual safety parameter configuration, a reset signal to the safety option can be required. For information about the reset functionality, see *chapter 6.3 Reset Function*.
6. Perform the commissioning test to ensure that the correct safety parameter configuration is transferred to the safety option. See *chapter 5.4 Commissioning Test*. Use the commissioning test report for the safety parameter configuration that is being transferred.

If replacing the frequency converter, use the same functionality and select *SO* in step 1 instead of *VL7*.

9.2.4 Copying Safe Parameter Configuration

The frequency converter allows to copy safety parameters using the LCP. This functionality allows to set-up a different frequency converter with exactly the same safety parameter configuration without using the MCT 10 Set-up Software.

Follow the steps below, to copy a pre-defined safety parameter configuration from 1 frequency converter to another:

1. Select *[1] All to LCP* in *0-50 LCP Copy*. Monitor the upload process on the progress bar.
2. Install the LCP with all the copied parameters on the frequency converter that needs to be updated.
3. Select 1 of the following options:
 - *[2] All from LCP* in *0-50 LCP Copy*, to copy all frequency converter parameters including the safety parameters.
 - *[9] Safety Par. from LCP* in *0-50 LCP Copy*, to copy only the safety parameter configuration.
4. Continue with steps 2–6 in *chapter 9.2.3 Mismatch of Safety Option Parameters* to finish the safety parameter copy process.

For the example of a commissioning set-up with LCP copying, see *chapter 5.6 Commissioning Set-up Examples*.

9.3 Error Conditions

This chapter provides troubleshooting tables for diagnosing error conditions associated with the safety option.

The safety option differentiates between the error types shown in *Table 9.1*.

Error type	Description	Effect on the system	Reset condition
Internal error	Severe exceptional error caused by the program run in the safety option. Cyclic program sequence is no longer possible for safety related reasons. The system enters the defined safe state.	Output S37 is switched off.	Reset possible by power cycling the frequency converter, or by restarting the safety option via <i>42-90 Restart Safe Option</i>
External error	Functional error, caused by an external process. Both systems continue to run cyclically and serve all requests from the communication interfaces. Sensing of the external process is also maintained. The system enters the defined safe state.	Output S37 is switched off.	Apply areset signal to the safety option via input DI2, the Reset key or via fieldbus. For information about the reset functionality, see <i>chapter 6.3 Reset Function</i> .

Table 9.1 Error Types

9.3.1 List of Error Conditions

Error No.	Description			LED Indications			
		Reason	Action	LED1	LED 2	LED 3	LED4
72	Internal error: Processor error. Reaction: STO.	-	Perform 1 of the following actions: <ul style="list-style-type: none"> Power cycle the frequency converter. Restart the safety option using parameter <i>42-90 Restart Safe Option</i>. If the problem persists, contact Danfoss. 			If safe fieldbus is enabled, the status of LED3 depends on the safe fieldbus status. Otherwise LED3 is off.	Red constant
73	Internal error: Safe output switch 1. Reaction: STO.						
74	Internal error: Safe output switch 2. Reaction: STO.						
75	Internal error: DI2 in PUST. Reaction: STO.	<ul style="list-style-type: none"> Safety input connected to DI2 has illegal signal level. Sensor is broken 	<ul style="list-style-type: none"> Check that configuration of DI2 <i>42-21 Type</i> parameter is set correctly or that the connected sensor is installed according to specification. Extend discrepancy time on the safe input using the MCT 10 Set-up Software Safe plug-in. 	Status of LED 1 and LED2 depends on safety function state assigned to DI1 and DI2.			
76	Internal error: DI1 in PUST. Reaction: STO.	<ul style="list-style-type: none"> Safety input connected to DI1 has illegal signal level. Sensor is broken 	<ul style="list-style-type: none"> Check that the configuration of DI1 (<i>42-21 Type</i> sub index [0]) is set correctly, or the connected sensor is installed according to specification. Extend discrepancy time on the safe input using the MCT 10 Set-up Software Safe plug-in. 				

Error No.	Description			Led Indications			
		Reason	Action	LED1	LED 2	LED 3	LED4
77	Internal error: Fail-safe data CRC mismatch. Reaction: STO.	The CRC of the safety option does not match the stored CRC value on the frequency converter. Severe exceptional error caused by the program run in the safety option.	Configure the safety option with MCT 10 safe plug-in or by CRC select/LCP copy Perform one of the following actions: <ul style="list-style-type: none"> Power cycle the frequency converter. Restart the safety option using parameter <i>42-90 Restart Safe Option</i>. If the problem persists, contact Danfoss. 	Status of LED 1 and LED2 depends on safety function state assigned to DI1 and DI2.		If safe fieldbus is enabled, the status of LED3 depends on the safe fieldbus status. Otherwise LED3 is off.	Red constant
78	Internal error: S1 S2 Communication Channel. Reaction: STO.						
80	Internal error: No CAN communication. Reaction: STO.						
81	Internal error: Undervoltage Vuc1. Reaction: STO.						
82	Internal error: Overvoltage Vuc1. Reaction: STO.						
83	Internal error: Undervoltage 24v IO. Reaction: STO.						
84	Internal error: Overvoltage 24v IO. Reaction: STO.						
85	Internal error: Undervoltage Vuc2. Reaction: STO.						
86	Internal error: Overvoltage Vuc2. Reaction: STO.						
87	Internal error: Undervoltage int5v. Reaction: STO.						
88	Internal error: Overvoltage int5v. Reaction: STO.						
89	Internal error: Memory error S2. Reaction: STO.						
90	Internal error: Memory error S1. Reaction: STO.						
91	Internal error: Undervoltage Vuc2 PLL. Reaction: STO.						
92	Internal error: Overvoltage Vuc2 PLL. Reaction: STO.						
93	Internal error: Undervoltage Vuc2 Core. Reaction: STO.						
94	Internal error: Overvoltage Vuc2 Core. Reaction: STO.						
95	Internal error: Undervoltage Vuc2 SDRAM. Reaction: STO.						
96	Internal error: Overvoltage Vuc2 SDRAM. Reaction: STO.						

Error No.	Description			Led Indications			
		Reason	Action	LED1	LED2	LED3	LED4
98	Internal error: Invalid customization file version. Reaction: STO.	Version of customization file of safety option stored in EEPROM does not match the customization file supported by the SW version of safety option.	Do a new configuration with MCT 10 safe plug-in which supports the SW version of safety option.	Status of LED 1 and LED2 depends on safety function state assigned to DI1 and DI2.		If safe fieldbus is enabled, the status of LED3 depends on the safe fieldbus status. Otherwise LED3 is off.	Red constant
100	Internal error: Invalid fieldbus option. Reaction: STO	The current fieldbus option is not supported.	Make sure that the fieldbus option meets the software version requirements. An update of the fieldbus option software may be required.				Red Constant
101	Internal error: PSD hard error. Reaction: STO.	There is an error in PSD hardware.	Perform one of the following actions: <ul style="list-style-type: none"> • Power cycle the frequency converter. • Restart the safety option using parameter <i>42-90 Restart Safe Option</i>. • If the problem persists, contact Danfoss. 				Red Constant
113	External error DI1. Reaction: STO.	<ul style="list-style-type: none"> • Safety input connected to DI1 has illegal signal level. • Sensor is broken. 	<ul style="list-style-type: none"> • Check that configuration of DI1 <i>42-21 Type</i> parameter is set correctly or the connected sensor is installed according to specification • Extend discrepancy time for DI1 using the MCT 10 Set-up Software Safe plug-in. 	Red Constant	Status depends on safety function state assigned to DI2.	Red flashing, cycle (on 500 ms, off 500 ms).	
114	External error DI2: Reaction STO	<ul style="list-style-type: none"> • Safety input connected to DI2 has illegal signal level. • Sensor is broken. 	<ul style="list-style-type: none"> • Check that configuration of DI2 <i>42-21 Type</i> parameter is set correctly or the connected sensor is installed according to specification. • Extend discrepancy time for DI2 using the MCT 10 Set-up Software Safe plug-in. 	Status depends on safety function state assigned to DI1.	Red constant		Red flashing, cycle (on 500 ms, off 500 ms).

Error No.	Description			Led Indications			
		Reason	Action	LED1	LED2	LED3	LED4
119	External error: Safe fieldbus destination address mismatch. Reaction: STO.	Destination address on the safe fieldbus is invalid.	Make sure that the addresses of the PLC and the safety option match.	Status of LED 1 and LED2 depends on safety function state assigned to DI1 and DI2.		Red flashing (500 ms on/off).	Red flashing (500 ms on/off).
120	External error: Safe fieldbus telegram mismatch. Reaction: STO.	Safe fieldbus telegram is invalid.	Check the telegram format settings in the safe PLC and the safety option.			Red flashing (500 ms on/off).	Red flashing (500 ms on/off).
121	External error: PROFIsafe configuration error. Reaction: STO.	PROFIsafe configuration is invalid.	Check the settings of the safety option and the PLC.			Red flashing (500 ms on/off).	Red flashing (500 ms on/off).

9.4 LCP Messages

Any errors on the safety option are indicated on the frequency converter.

The following options are available for detailed diagnostics and error detection:

- LEDs on the front of the safety option provide information on operating states. The LEDs are used to indicate the status of the option, i.e. active safety functions, failures and warnings, if any.
- LCP text or info via bus display the status of the safety functions (for example STO).

The following messages are displayed in online mode in the MCT 10 Set-up Software:

- Status of the safety option.
- Internal and external errors and the corresponding troubleshooting tips.

To configure the LCP to show the safety option specific information, use the parameters in parameter group 0-2* *LCP Display*.

0-20 Display Line 1.1 Small, 0-21 Display Line 1.2 Small, and 0-22 Display Line 1.3 Small have the following options:

- 42-82 Safe Control Word.
- 42-83 Safe Status Word.
- 42-85 Active Safe Func.

0-23 Display Line 2 Large, 0-24 Display Line 3 Large have the following options:

- 42-82 Safe Control Word.
- 42-83 Safe Status Word.
- 42-86 Safe Option Info.

9.4.1 LCP Status Messages

This section describes the LCP status messages related to the safety option. The set of messages is different depending on whether or not a safe fieldbus is enabled. *Table 9.2* contains messages that are shown regardless of the safe fieldbus state. *Table 9.3* contains messages that are shown only when the safe fieldbus is disabled.

LCP Message	Description
	The safety function was activated via a digital input or PROFIsafe.
	The source that triggered the safety condition has ceased, but the safety option is waiting for the reset signal to continue normal operation. The LCP shows this message only if the manual restart behaviour is selected for the digital input. The LCP does not show this message when the PROFIsafe control word activates the safety function, since the PROFIsafe configuration uses automatic restart behaviour.

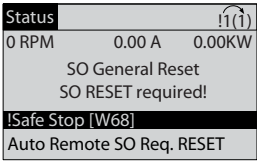
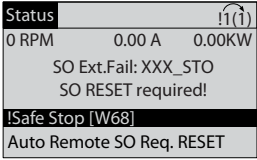
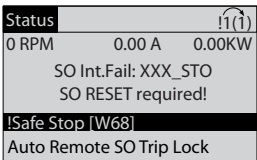
LCP Message	Description
 <p>130BE092.10</p>	<p>The LCP shows this message after resetting the safety option with MCT 10 Set-up Software. After the reset, the safety option is set to blank initial state. For more information, see <i>chapter 6.1.3 Password Protection</i>.</p>
 <p>130BE093.10</p>	<p>The LCP shows this message when the safety option detects an external error. The LCP shows the error number. For information about the errors and possible solutions, see <i>chapter 9.3.1 List of Error Conditions</i>. To resume normal operation, ensure that the source of the error has ceased and reset the safety option.</p>
 <p>130BE094.10</p>	<p>The LCP shows this message when the safety option detects an internal error. The LCP shows the error number. For information about the errors and possible solutions, see <i>chapter 9.3.1 List of Error Conditions</i>. To resume normal operation, ensure that the source of the error has ceased and power cycle the safety option.</p>

LCP Message	Description
 <p>130BE095.10</p>	<p>The LCP shows this message when the safety option detects an issue and cannot handle the issue as an internal or external error. A manual user action is required in this situation. This situation can occur in the following cases:</p> <ul style="list-style-type: none"> • PUST timer expired. To resume normal operation, power cycle the safety option. • DI1 offline timer expired. Test DI1 by activating it. • DI2 offline timer expired. Test DI2 by activating it. <p>To configure the LCP to show a dedicated message for each warning, select <i>42-86 Safe Option Info</i> in <i>0-23 Display Line 2 Large</i> or in <i>0-24 Display Line 3 Large</i>.</p>

Table 9.2 LCP Messages

LCP Message	Description
 <p>130BE096.10</p>	<p>The safety option customisation with MCT 10 Set-up Software is completed. Reset the safety option to start the normal operation.</p>
 <p>130BE097.10</p>	<p>The safety option customisation with MCT 10 Set-up Software was aborted. The safety option uses the previous configuration. Reset the safety option to start the normal operation.</p>
 <p>130BE098.10</p>	<p>The safety option was powered up. After the Power up Self Test (PUST), the safety option requests a reset.</p>

Table 9.3 LCP Messages, Safe Fieldbus Disabled

NOTICE

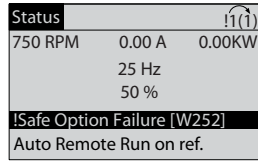
When the safety option indicates an error or warning, the LCP displays the warning Safe Option Failure [W252] if the warning is not overwritten by a higher priority alarm. As a possible solution, check the connection between the safety option terminal S12 and terminal 37 on the control card.

10 Specifications

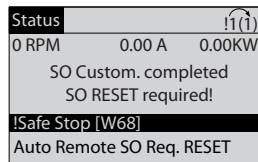
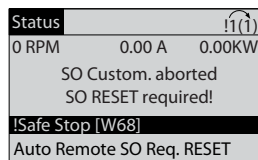
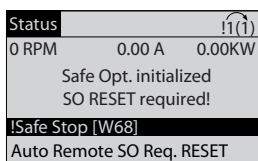
10.1 Consumption

Safety option

Power consumption	2 W
Current consumption VCC (5 V)	<200 mA
Current consumption VDD (24 V)	<30 mA (<25 mA for MCB 152)

10.2 Inputs

Digital inputs

Number of digital inputs	4 (2 x 2-channel digital safety input)
Input voltage range	0-24 V DC
Input voltage, logic 0	<5 V DC
Input voltage, logic 1	>12 V DC
Input voltage (maximum)	28 V DC
Input current (minimum)	6 mA @Vin=24 V
Input resistance	approximately 4 k Ω
Galvanic isolation	No
Short circuit-proof	Yes
Input pulse recognition time (min)	3 ms
Discrepancy time (min)	9 ms
Cable length	<30 m (screened or unscreened cable) >30 m (screened cable)

10.3 Outputs

Digital output (Safe output)

Number of outputs	1
Output voltage low	<2 V DC
Output voltage high	>19.5 V DC
Output voltage (maximum)	24.5 V DC
Maximum output current (@24 V)	<100 mA
Maximum output current (@0 V)	<0.5 mA
Galvanic Isolation	No
Diagnostic test pulse	300 μ s
Short circuit-proof	Yes
Cable length	<30 m (screened cable)

24 V supply output

Supply voltage	24 V DC (Voltage tolerance: +0.5 V DC to -4.5 V DC)
Maximum output current	150 mA
Short circuit-proof	Yes
Cable length	<30 m (screened or unscreened cable) >30 m (screened cable)

10.4 Other Specifications

Connector cable dimensions

Connector cable dimensions	0.75 mm ² /AWG 18, AEH without plastic collar in accordance with DIN 46228/1
----------------------------	-----------------------------------------------------------------------------------------

Reset characteristics

Manual reset time	\leq 5 ms (safety option) \leq 5 ms (frequency converter)
-------------------	------------------------------------------------------------------

	≤ 10 ms (fieldbus)
Manual reset pulse time	$10 \mu\text{s}$ (safety option and frequency converter)
Automatic reset time	≤ 4 ms
Start-up reset time	≤ 5 s (42-90 Restart Safe Option)
Response time	
Input to output response time	≤ 2 ms
Cross error detection time	≤ 3 ms (@activated output)
Minimum PROFIsafe watchdog time	67 ms
STO through PROFIsafe	23 ms
PROFIsafe version 2.4 supported	Yes
PROFIdrive version 3.00.4 supported	Yes

10.5 Safety Characteristic Data

European directives	Machinery Directive (2006/42/EC)	EN ISO 13849-1 EN IEC 62061 EN IEC 61800-5-2	
	EMC Directive (2004/108/EC)	EN 50011 EN 61000-6-3 EN 61800-3	
	Low Voltage Directive (2006/95/EC)	EN 50178 EN 61800-5-1	
Safety standards	Safety of Machinery	EN ISO 13849-1 IEC 62061 IEC 60204-1	
	Functional Safety	IEC 61508-1 to -7 IEC 61800-5-2 IEC 61784-3	
Safety function		IEC 61800-5-2	IEC 60204-1
		Safe Torque Off (STO)	Stop Category 0
Safety performance	Safety Integrity Level	SIL 2 SIL CL2	
	HFT (IEC 61508)	Hardware Fault Tolerance = 1	
	Subsystem Classification	Type B	
	Probability of Dangerous Failure per Hour	PFH: $1,52 \cdot 10^{-8}$	
	Probability of Dangerous Failure on Demand	PFD: $1,33 \cdot 10^{-3}$	
	Category	Cat 3	
	Performance Level	PL d (cat 3)	
	Mean Time to Dangerous Failure of each Channel	MTTFd: 245 years (High)	
	Average Diagnostic Coverage	DC _{ave} : 86% (Low)	
	Safe Failure Fraction	SFF: 90%	
Proof Test Interval	20 Years		

Table 10.1 Safety Characteristic Data

The safety-related characteristic data are valid for all safety functions.

When calculating the safety characteristic data, consider all units used within a safety function.

11 Appendix

11.1 Abbreviations and Conventions

Blank initial state	The blank initial state is the state of the safety option when it leaves the factory with default settings.
Cat.	Category (EN ISO 13849-1).
CCF	Common cause failure (IEC 61508, IEC 62061, EN 61511-1, EN ISO 13849-1).
CCW	Counterclockwise .
CW	Clockwise.
DC	Diagnostic coverage (EN ISO 13849-1, IEC 62061(IEC 61508-2)).
Degree of protection	The degree of protection is a standardised specification for electrical equipment that describes the protection against the ingress of foreign objects and water (for example: IP20).
Dlx	DI1: Digital Input 1. DI2: Digital Input 2.
EMC	Electromagnetic compatibility.
Error	Discrepancy between a computed, observed or measured value or condition and the specified or theoretically correct value or condition. .
Error class	Classification of errors into groups. The different error classes allow for specific responses to errors, for example by severity.
F-DIO	Fail safe digital input and output.
F-PLC	Fail safe PLC.
Fatal error	An error that makes the product unable to function.
GSD	General station description. A GSD file contains characteristics of an IO device.
MTTF/MTTFd	Mean time to failure/Mean time to dangerous failure (EN ISO 13849-1).
OSSD	Output signal switching device (EN 61496-1).
Parameter	Device data and values that can be read and set (to a certain extent) by the user.
PDS(SR)	Power drive system (safety related).
PELV	Protective extra low voltage, low voltage with isolation. For more information: IEC 60364-4-41 or IEC 60204-1.
PFD	Probability of failure on demand (IEC 61508, IEC 62061).
PFH	Probability of failure per hour (IEC 62061 and IEC61508).
PLC	Programmable logic controller.
PL/ Performance Level	Discrete level used to specify the ability of safety-related parts of control systems to perform a safety function under foreseeable conditions (EN ISO 13849-1).
PSD	PROFIsafe driver.
PUST	Power up self test. Internal self test on the safety option.

RS-485	Fieldbus interface as per EIA-422/485 Bus Description, which enables serial data transmission with multiple devices.
Safe state	The safety option goes to a safe state if it detects an error.
SF	Safe function.
SIL	Safety integrity level (IEC61508, IEC61800-5-2, IEC62061).
SO	Safety Option.
SRECS	Safety related electrical control system (IEC 62061).
SRP/CS	Safety related parts of control systems (EN ISO 13849-1).
STO - Safe Torque Off	Safety function in accordance with EN IEC 61800-5-2, prevents torque from being generated by the motor. This function is integrated within the frequency converter as standard. STO is the abbreviation for Safe Torque Off. .
TIA	Totally integrated automation.
TM	Mission time (EN ISO 13849-1).
Warning	If the term is used outside the context of safety instructions, a warning alerts to a potential problem that was detected by a monitoring function. A warning does not cause a transition of the operating state.

Table 11.1 Abbreviations

Conventions

- Numbered lists indicate procedures.
- Bullet lists indicate other information and description of illustrations.
- Italicised text indicates:
 - cross reference
 - link
 - footnote
 - parameter name, parameter group name, parameter option
- All dimensions are in mm (inch).
- MCB 15x refers to all variants of Safety Option MCB (MCB 150, MCB 151, MCB 152).

Index

A

Abbreviation..... 45
 Additional resources..... 5
 Application example..... 31
 Approval..... 5

C

Category 0 stop..... 9
 Command..... 6
 Commissioning..... 16
 Commissioning software..... 20
 Compatibility..... 5
 Compliance..... 5
 Configuration..... 7, 20, 34
 Control system..... 6
 Convention..... 45
 Copying parameters..... 35

D

Digital input..... 4, 11, 31
 Discharge time..... 7
 Discrepancy..... 11, 26, 45
 Disposal instruction..... 5

E

Error condition..... 36

H

High voltage..... 6

I

Installation..... 13
 Internal error..... 10, 37

L

LCP copy..... 35
 LCP message..... 40
 Load sharing..... 6

M

MCT 10 Safe Plug-in..... 20, 38, 39

N

Normal operation..... 18

P

Parameter..... 25
 Parameter mismatch..... 34
 PFD..... 10
 PFH..... 10
 PROFIsafe..... 20, 23
 PROFIsafe configuration..... 20

Q

Qualified personnel..... 6

R

Recycling..... 5
 Reference..... 31
 Removing the safety option..... 33
 Repair..... 33
 Requirements..... 5
 Reset..... 10, 11, 16, 21, 22, 25, 26, 36, 37, 38, 39, 43
 Response time..... 12
 Risk assessment..... 7

S

Safe Torque Off..... 4, 9, 10, 11, 33
 Safety control system..... 10
 Safety function..... 9, 10, 11
 Safety sensor..... 4, 11
 Sensor..... 7, 11, 31
 Sensor type..... 11
 Signal..... 4, 6, 11, 12, 14, 18
 SISTEMA..... 8
 Specifications..... 43
 Step 7..... 23
 STO..... 11, 45
 Supply voltage..... 4, 14, 34, 43

T

Test pulse pattern..... 12, 26
 TIA..... 24
 Troubleshooting..... 33

U

Unintended start..... 7

W

Warranty..... 33

Y

Yearly test..... 33



.....
Danfoss can accept no responsibility for possible errors in catalogues, brochures and other printed material. Danfoss reserves the right to alter its products without notice. This also applies to products already on order provided that such alterations can be made without subsequential changes being necessary in specifications already agreed. All trademarks in this material are property of the respective companies. Danfoss and the Danfoss logotype are trademarks of Danfoss A/S. All rights reserved.
.....

Danfoss A/S
Ulsnaes 1
DK-6300 Graasten
www.danfoss.com/drives

