

GE
Industrial Solutions

AF-650 GP™ Safe Torque Off Operating Guide



a product of
ecomagination





Contents

1 Introduction	2
1.1 Purpose of the Manual	2
1.2 Additional Resources	2
1.3 Functional Overview	2
1.4 Approvals and Certifications	2
1.5 Symbols, Abbreviations, and Conventions	3
2 Safety	4
2.1 Safety Symbols	4
2.2 Qualified Personnel	4
2.3 Safety Precautions	4
3 Installation	6
3.1 Safety Instructions	6
3.2 STO Installation	6
3.3 Installation in Combination with OPCPTC	7
4 Commissioning	8
4.1 Safety Instructions	8
4.2 Activation of STO	8
4.3 Parameter Settings for STO in Combination with PTC Thermistor Card OPCPTC	8
4.4 Automatic/Manual Restart Behavior	8
4.5 STO Commissioning Test	8
4.6 System Configuration Security	9
4.7 Service and Maintenance	9
5 STO Technical Data	10
Index	11



1 Introduction

1.1 Purpose of the Manual

This manual provides information for use of GE frequency converters in functional safety applications. The manual includes information about functional safety standards, GE frequency converter Safe Torque Off (STO) function, and the related installation and commissioning as well as service and maintenance for STO.

1.2 Additional Resources

This manual is targeted at users already familiar with the frequency converters. It is intended as a supplement to the manuals and instructions available for download at www.geindustrial.com/products/drives. Read the instructions shipped with the frequency converter and/or frequency converter option before installing the unit, and observe the instructions for safe installation.

1.3 Functional Overview

1.3.1 Introduction

The Safe Torque Off (STO) function is a component in a safety control system. STO prevents the unit from generating the voltage required to rotate the motor.

NOTICE

Select and apply the components in the safety control system appropriately to achieve the desired level of operational safety. Before integrating and using STO in an installation, carry out a thorough risk analysis on the installation to determine whether the STO functionality and safety levels are appropriate and sufficient.

The frequency converter is available with:

- Safe Torque Off (STO), as defined by EN IEC 61800-5-2
- Stop Category 0, as defined in EN 60204-1

The frequency converter integrates the STO functionality via control terminal 37.

The frequency converter with STO functionality is designed and approved suitable for the requirements of:

- Category 3 in EN ISO 13849-1
- Performance Level "d" in EN ISO 13849-1
- SIL 2 in IEC 61508 and EN 61800-5-2
- SILCL 2 in EN 62061

1.3.2 Products Covered

The STO function is available for the following types of frequency converters:

- General Purpose Drives AF-650 GP

1.4 Approvals and Certifications



More approvals and certifications are available. Contact a local GE partner.

Applied standards and compliance

Use of STO on terminal 37 requires that the user satisfies all provisions for safety including relevant laws, regulations, and guidelines.

The integrated STO function complies with the following standards:

- EN 60204-1: 2006 Stop category 0 – uncontrolled stop
- IEC/EN 61508: 2010 SIL2
- IEC/EN 61800-5-2: 2007
- IEC/EN 62061: 2005 SIL CL2
- EN ISO 13849-1: 2008 Category 3 PL d



1.5 Symbols, Abbreviations, and Conventions

Abbreviation	Reference	Description
Cat.	EN ISO 13849-1	Category, level "B, 1–4"
DC		Diagnostic coverage
FIT		Failure in time: 1E-9/hour
HFT	EN IEC 61508	Hardware fault tolerance: HFT = n means that n+1 faults could cause a loss of the safety function
MTTFd	EN ISO 13849-1	Mean time to failure - dangerous. Unit: Years
PFH	EN IEC 61508	Probability of dangerous failures per hour. Consider this value if the safety device is operated in high demand or continuous mode of operation, where the frequency of demands for operation made on a safety-related system is greater than one per year.
PFD	EN IEC 61508	Average probability of failure on demand, value used for low demand operation.
PL	EN ISO 13849-1	Discrete level used to specify the ability of safety-related parts of control systems to perform a safety function under foreseeable conditions. Levels a-e.
SIL	EN IEC 61508 EN IEC 62061	Safety integrity level
STO	EN IEC 61800-5-2	Safe Torque Off
SS1	EN IEC 61800-5-2	Safe Stop 1
SRECS	EN IEC 62061	Safety related electrical control system
SRP/CS	EN ISO 13849-1	Safety related parts of control systems
PDS/SR	EN IEC 61800-5-2	Power drive system (safety-related)

Table 1.1 Abbreviations Related to Functional Safety

Conventions

Numbered lists indicate procedures.

Bullet lists indicate other information and description of illustrations.

Italicized text indicates:

- Cross-reference
- Link
- Parameter name



2 Safety

2.1 Safety Symbols

The following symbols are used in this manual:

⚠ WARNING

Indicates a potentially hazardous situation that could result in death or serious injury.

⚠ CAUTION

Indicates a potentially hazardous situation that could result in minor or moderate injury. It can also be used to alert against unsafe practices.

NOTICE

Indicates important information, including situations that can result in damage to equipment or property.

2.2 Qualified Personnel

Only persons with proven skills are allowed to assemble, install, program, commission, maintain, and decommission the products. Persons with proven skills

- Are qualified electrical engineers, or persons who have received training from qualified electrical engineers and are suitably experienced to operate devices, systems, plant, and machinery in accordance with the general standards and guidelines for safety technology.
- Are familiar with the basic regulations concerning health and safety/accident prevention.
- Have read and understood the safety guidelines given in this manual and also the instructions given in the operating instructions of the frequency converter.
- Have a good knowledge of the generic and specialist standards applicable to the specific application.

Users of Power Drive Systems (Safety Related) (PDS(SR)) are responsible for:

- Hazard and risk analysis of the application.
- Identifying safety functions required and allocating SIL or PLr to each of the functions.
- Other subsystems and the validity of signals and commands from them.
- Designing appropriate safety-related control systems (hardware, software, parameterization, and so on).

Protective measures

- Only qualified and skilled personnel is allowed to install and commission safety engineering systems.
- Install the frequency converter in an IP54 cabinet as per IEC 60529 or in an equivalent environment. In special applications, a higher IP degree may be necessary.
- Ensure short-circuit protection of the cable between the safety option and the external safety device according to ISO 13849-2 table D.4. When external forces influence the motor axis (for example suspended loads), extra measures (for example a safety holding brake) are required to eliminate hazards.

2.3 Safety Precautions

See the *Safety* chapter in the relevant *operating instructions* for general safety precautions.

⚠ CAUTION

After installation of STO, perform a commissioning test as specified in *chapter 4.5 STO Commissioning Test*. A passed commissioning test is mandatory after first installation and after each change to the safety installation.

⚠ WARNING

RISK OF DEATH AND SERIOUS INJURY

If external forces act on the motor for example, in case of vertical axis (suspended loads) - and an unwanted movement, for example caused by gravity, could cause a hazard, the motor must be equipped with extra measures for fall protection. For example, install extra mechanical brakes.

⚠ WARNING

RISK OF DEATH AND SERIOUS INJURY

STO (that is, removal of 24 V DC voltage supply to terminal 37) does not provide electrical safety. The STO function itself is not sufficient to implement the Emergency-Off function as defined by EN 60204-1. Emergency-Off requires measures of electrical isolation, for example, by switching off mains via an additional contactor.

**⚠ WARNING****RISK OF ELECTRICAL SHOCK**

The STO function does NOT isolate mains voltage to the frequency converter or auxiliary circuits. Perform work on electrical parts of the frequency converter or the motor only after isolating the mains voltage supply and waiting the length of time specified in the *Safety* chapter in the relevant *operating instructions*. Failure to isolate the mains voltage supply from the unit and waiting the time specified could result in death or serious injury.

- Do not stop the frequency converter by using the STO function. If a running frequency converter is stopped by using the function, the unit trips and stops by coasting. If this limitation is not acceptable, for example, because it causes danger, use the appropriate stopping mode to stop the frequency converter and machinery before using the STO function. Depending on the application, a mechanical brake may be required.
- STO is suitable for performing mechanical work on the frequency converter system or affected area of a machine only. It does not provide electrical safety. STO must not be used as a control for starting and/or stopping the frequency converter.

⚠ CAUTION

Automatic restart behavior is only allowed in 1 of the 2 situations:

- The unintended restart prevention is implemented by other parts of the STO installation.
- A presence in the dangerous zone can be physically excluded when STO is not activated. In particular, paragraph 6.3.3.2.5 of ISO 12100: 2010 must be observed.

⚠ WARNING**RISK OF DEATH AND SERIOUS INJURY**

The STO function can be used for asynchronous, synchronous, and permanent magnet motors. 2 faults can occur in the power semiconductor of the frequency converter. When using synchronous or permanent magnet motors, a residual rotation can result from the faults. The rotation can be calculated to angle = $360 / (\text{number of poles})$. The application using synchronous or permanent magnet motors must take this residual rotation into consideration and ensure that it does not pose a safety risk. This situation is not relevant for asynchronous motors.

NOTICE

Perform a risk assessment for each stop function to determine the selection of a stop category in accordance with EN 60204-1:

- Stop Category 0 is achieved with immediate removal of power to the actuator, resulting in an uncontrolled coast to stop. STO according to EN 61800-5-2 accomplishes a Stop Category 0 stop.
- Stop Category 1 is achieved with power available to the machine actuators to achieve the stop. Power is removed from the actuators when the stop is achieved according to EN 61800-5-2 Safe Stop 1 (SS1).
- Stop Category 2 is a controlled stop with power available to the machine actuators. The stop is followed by a holding position under power.

NOTICE

When designing the machine application, timing and distance must be considered for a coast to stop (Stop Category 0 or STO). For more information regarding stop categories, refer to EN 60204-1.

3 Installation

3.1 Safety Instructions

3

CAUTION

The operator or electrical installer is responsible for proper grounding and compliance with all applicable national and local safety regulations.

See *chapter 2 Safety* and the relevant frequency converter operating instructions. Also, always observe the instructions provided by the motor manufacturer.

3.2 STO Installation

For motor connection, AC mains connection, and control wiring, follow the instructions for safe installation in the *operating Instructions* of the frequency converter.

For installation with the Ex-certified PTC Thermistor Card OPCPTC, see *chapter 3.3 Installation in Combination with OPCPTC*.

Enable the integrated STO as follows:

1. Remove the jumper wire between control terminals 37 and 12 or 13. Cutting or breaking the jumper is not sufficient to avoid short-circuiting. (See jumper on *Illustration 3.1*)

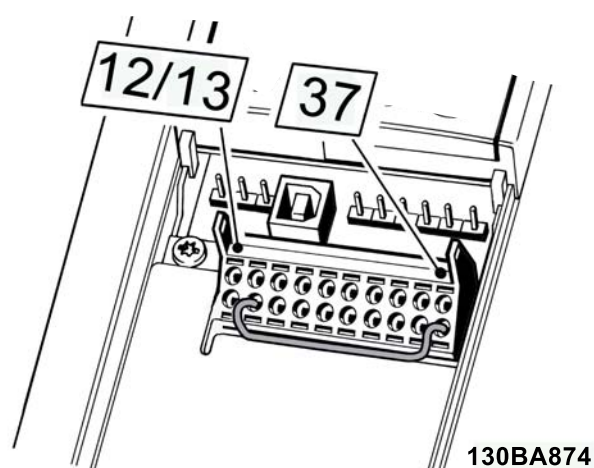
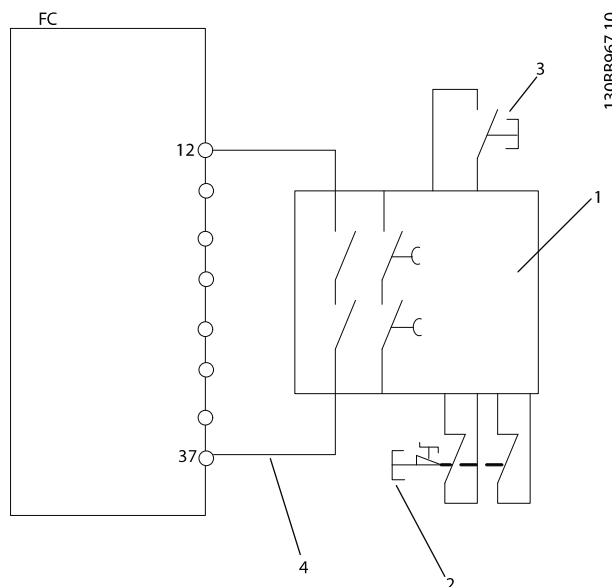

Illustration 3.1 Jumper between Terminal 12/13 (24 V) and 37

2. Connect an external safety monitoring relay via a NO safety function to terminal 37 (STO) and either terminal 12 or 13 (24 V DC). Follow the installation instructions for the safety monitoring

relay, and ensure that the safety monitoring relay complies with Category 3 /PL “d” (ISO 13849-1) or SIL 2 (EN 62061 and IEC 61508).



1	Safety relay (cat. 3, PL d or SIL2)
2	Emergency stop button
3	Reset button
4	Short-circuit protected cable (if not inside installation IP54 cabinet). See ISO 13849-2 Table D.4 for further information.

Illustration 3.2 Installation to Achieve a Stop Category 0 (EN 60204-1) with Safety Cat. 3/PL “d” (ISO 13849-1) or SIL 2 (EN 62061 and IEC 61508).

3. Complete wiring according to the instructions given in the *Operating Instructions* of the frequency converter.

3.3 Installation in Combination with OPCPTC

Thermistor Card OPCPTC Operating Instructions for further details.

NOTICE

Combination of PTC Thermistor Card OPCPTC and STO function is only available for AF-650 GP

PTC Thermistor Card OPCPTC uses Terminal 37 as its safety-related switch-off channel.

- Ensure that the output X44/12 of OPCPTC is AND-ed with the safety-related sensor (such as emergency stop button, safetyguard switch, and so on) that activates STO. This means that the output to STO terminal 37 is HIGH (24 V) only if both the signal from OPCPTC output X44/12 and the signal from the safety-related sensor are HIGH. If at least 1 of the 2 signals is LOW, then the output to terminal 37 must be LOW too.
- Ensure that the safety device with AND-logic complies with the needed safety level.
- Short-circuit protect the connection from the output of the safety device with safe AND-logic to the STO terminal 37, see *Illustration 3.3*.

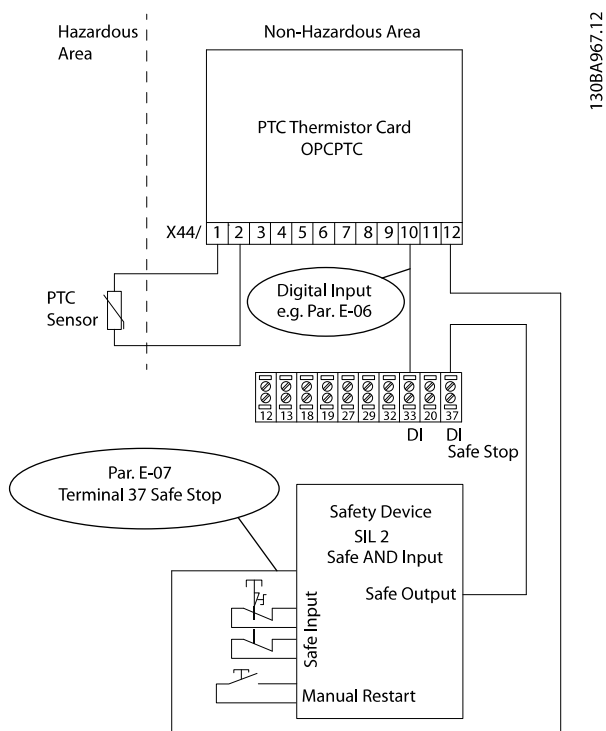

Illustration 3.3 Combination of an STO Application and an OPCPTC Application

Illustration 3.3 shows a restart input for the external safety device. This means that in this installation, parameter E-07 Terminal 37 Safe Stop can be set to value [7] PTC 1 & Relay W or [8] PTC 1 & Relay A/W. Refer to PTC



4 Commissioning

4.1 Safety Instructions

CAUTION

The operator or electrical installer is responsible for proper grounding and compliance with all applicable national and local safety regulations.

See *chapter 2 Safety* and the relevant frequency converter operating instructions. Also, always observe the instructions provided by the motor manufacturer.

4.2 Activation of STO

The STO function is activated by removing the voltage at terminal 37 of the frequency converter. By connecting the frequency converter to external safety devices providing a safe delay, an installation for a Safe Stop 1 can be obtained. External safety devices must fulfill Cat./PL or SIL when connected to terminal 37. The STO function can be used for asynchronous, synchronous, and permanent magnet motors.

When the STO function (terminal 37) is activated, the frequency converter issues an alarm, trips the unit, and coasts the motor to a stop. Manual restart is required. Use the STO function to stop the frequency converter in emergency stop situations. In normal operating mode when STO is not required, use the standard stop function instead. Ensure that requirements according to ISO 12100 paragraph 6.3.3.2.5 are fulfilled before using the automatic restart function.

4.3 Parameter Settings for STO in Combination with PTC Thermistor Card OPCPTC

When OPCPTC is connected, additional selections are available for *parameter E-07 Terminal 37 Safe Stop* ([4] *PTC 1 Alarm* to [9] *PTC 1 & Relay W/A*).

- Selections [1]* *Safe Stop Alarm* and [3] *Safe Stop Warning* are still available, but are for installations without OPCPTC or any external safety devices. If [1]* *Safe Stop Alarm* or [3] *Safe Stop Warning* are selected and OPCPTC is triggered, the frequency converter reacts with *alarm 72, Dangerous Failure* and coasts the motor safely, without automatic restart.
- Do not select [4] *PTC 1 Alarm* and [5] *PTC 1 Warning* when an external safety device is used. Those selections are for when only OPCPTC uses the STO.

If selection [4] *PTC 1 Alarm* or [5] *PTC 1 Warning* is selected and the external safety device triggers STO, the frequency converter issues *alarm 72, Dangerous Failure* and coasts the motor safely, without automatic restart.

- Select [6] *PTC 1 & Relay A* to [9] *PTC 1 & Relay W/A* for the combination of external safety device and OPCPTC.

CAUTION

Selections allow for automatic restart when the external safety device is de-activated.

Before selecting [7] *PTC 1 & Relay W* or [8] *PTC 1 & Relay A/W*, ensure that:

- The unintended restart prevention is implemented by other parts of the STO installation, or
- A presence in the dangerous zone can be physically excluded when STO is not activated. In particular, paragraph 6.3.3.2.5 of ISO 12100:2010 must be observed.

See *PTC Thermistor Card OPCPTC Operating Instructions* for further information.

4.4 Automatic/Manual Restart Behavior

By default the STO function is set to unintended restart prevention behavior. To terminate STO and resume normal operation:

1. Reapply 24 V DC supply to Terminal 37.
2. Give a reset signal (via Bus, Digital I/O, or [Reset] key).

Set the STO function to automatic restart by setting the value of *parameter E-07 Terminal 37 Safe Stop* from default value [1]* *Safe Stop Alarm* to value [3] *Safe Stop Warning*. Automatic restart means that STO is terminated, and normal operation is resumed, when the 24 V DC is applied to terminal 37. No reset signal is required.

4.5 STO Commissioning Test

After installation and before first operation, perform a commissioning test of the installation, using STO. Perform the test again after each modification of the installation or application involving the STO.

**NOTICE**

A successful commissioning test of the STO function is required after the initial installation, and after each subsequent change to the installation.

To perform a commissioning test:

- Follow the instructions in *chapter 4.5.1 Restart Prevention for STO Application* for applications without automatic restart after a safe stop, or
- Follow the instructions in *chapter 4.5.2 Automatic Restart of STO Application* for applications with automatic restart after a safe stop

4.5.1 Restart Prevention for STO Application

Application where *parameter E-07 Terminal 37 Safe Stop* is set to default value [1]* *Safe Stop Alarm* :

1. Remove the 24 V DC voltage supply to terminal 37 using the interrupt device while the frequency converter drives the motor (that is mains supply is not interrupted).
2. Check that:
 - 2a The motor coasts.
 - 2b The mechanical brake activates (if connected).
 - 2c If the local control panel (LCP) is mounted, it shows *alarm 68, Safe Stop*.
3. Reapply 24 V DC to terminal 37.
4. Ensure that the motor remains in the coasted state, and the mechanical brake (if connected) remains activated.
5. Send reset signal (via Bus, Digital I/O, or [Reset] key).
6. Ensure that the motor becomes operational again.

The commissioning test is successfully completed when all the given steps are passed.

4.5.2 Automatic Restart of STO Application

Application where *parameter E-07 Terminal 37 Safe Stop* is set to [3] *Safe Stop Warning* :

1. Remove the 24 V DC voltage supply to terminal 37 by the interrupt device while the frequency converter drives the motor (that is mains supply is not interrupted).
2. Check that:

- 2a The motor coasts.
- 2b The mechanical brake activates (if connected).
- 2c If the local control panel (LCP) is mounted, it shows *warning 68, Safe Stop*.
3. Reapply 24 V DC to terminal 37.
4. Ensure that the motor becomes operational again.

The commissioning test is successfully completed when all the given steps are passed.

NOTICE

See the warning on the restart behavior in *chapter 2.3 Safety Precautions*.

4.6 System Configuration Security

- Security measures are the responsibility of the user.
- The frequency converter parameters can be password-protected.

4.7 Service and Maintenance

For PL d or SIL2 it is a must, for lower PL or SIL it is recommended to conduct a functional test every 12 months to detect any failure or malfunction of the STO functionality.

To conduct the functional test, perform the following steps (or a similar method suitable for the application):

1. Remove the 24 V DC voltage supply at terminal 37.
2. Check if the LCP shows *alarm 68, Safe Stop*.
3. Verify that the frequency converter trips the unit.
4. Verify that the motor is coasting and comes to a complete stop.
5. Verify that the motor cannot be started.
6. Reconnect the 24 V DC voltage supply to terminal 37.
7. Verify that the motor is not started automatically and restarts only by giving a reset signal (via Bus, Digital I/O, or [Reset] key).



5 STO Technical Data

NOTICE

For technical specifications and operating conditions for the frequency converter, refer to the relevant *operating instructions* of the frequency converter.

NOTICE

The STO signal must be SELV or PELV supplied.

5

European Directives	Machinery Directive (2006/42/EC)	EN ISO 13849-1	
		EN IEC 62061	
		EN IEC 61800-5-2	
	EMC Directive (2004/108/EC)	EN 50011	
		EN 61000-6-3	
		EN 61800-3	
Low Voltage (2006/95/EC)	EN 50178		
	EN 61800-5-1		
Safety Standards	Safety of Machinery	EN ISO 13849-1, IEC 62061, IEC 60204-1	
	Functional Safety	IEC 61508-1 to -7, IEC 61800-5-2	
Safety Function		IEC 61800-5-2	IEC 60204-1
		Safe Torque Off (STO)	Stop Category 0
Safety Performance	ISO 13849-1		
	Category	Cat 3	
	Diagnostic Coverage	DC: 90% (Medium)	
	Mean Time to Dangerous Failure	MTTFd: 14000 years (High)	
	Performance Level	PL d	
	IEC 61508/IEC 62061		
	Safety Integrity Level	SIL 2, SIL CL2	
	Probability of Dangerous Failure per Hour	PFH: 1E-10/h (High Demand Mode)	
	Probability of Dangerous Failure on Demand	PFD: 1E-10 (Low Demand Mode)	
	Hardware Fault Tolerance	HFT: 0 (1oo1)	
	Proof Test Interval T1	20 Years	
	Mission time TM	20 Years	
Reaction time	Input to output response time	Maximum 20 ms, 60 ms for specific variants ¹⁾	

Table 5.1 Technical Data

1) AF-650 GP High Power Drives with enclosure size 6:

- 400 V: 450/500 kW (600/650 hp) – 800/1000 kW (1075/1350 hp) (High Overload/Normal Overload).
- 690 V: 630/710 kW (850/950 hp) – 1800/2000 kW (2400/2700 hp) (High Overload/Normal Overload).



Index

A

Abbreviations..... 3
Activation..... 8
Alarm..... 8
Approvals..... 2
Automatic restart..... 8, 9

C

Certifications..... 2
Command..... 4
Commissioning test..... 9
Control system..... 4
Conventions..... 3

E

External safety devices..... 8

I

Identification..... 2
Installation..... 7

M

Maintenance..... 9
Mechanical brake..... 9

O

Output..... 7

P

Parameter settings..... 8
Products covered..... 2

Q

Qualified personnel..... 4

R

Restart behavior..... 8
Restart prevention..... 8, 9

S

Safety device..... 7
Safety-guard switch..... 7
Safety-related sensor..... 7
Selections..... 8
Signal..... 4, 7

SIL CL2..... 2
SIL2..... 2
Standards and compliance..... 2
Switch-off channel..... 7
Symbols..... 3

T

Technical data..... 10
Termination..... 8
Thermistor card..... 7

U

Unintended restart prevention..... 8

The instructions do not purport to cover all details or variations in equipment nor to provide for every possible contingency to be met in connection with installation, operation or maintenance. Should further information be desired or should particular problems arise which are not covered sufficiently for the purchaser's purposes, the matter should be referred to the GE company.

AF-650 GP is trademark of the General Electric Company.

GE POWER CONTROLS IBÉRICA S.L.
C/ Miño 122 - Naves E-F
Pol. Inds. Santa Margarita
08223 Tarrasa - Barcelona (Spain)



imagination at work

130R0684



DET-858