

Contents

1 General Information	3
1.1 Important Safety Warnings	3
1.2 Copyright	3
1.3 Product Names and Trademarks	3
1.4 Disclaimer	3
1.5 Approvals	3
1.6 Service and Support	4
2 Introduction	5
2.1 System Overview	5
2.2 Terminology	6
2.3 Purpose of the Operating Instructions	6
2.4 Additional Resources	6
3 Safety	7
3.1 Symbols used in this Manual	7
3.2 General	7
3.3 Safety Instructions and Precautions for the ISD 410 Servo System	7
3.4 Qualified Personnel	9
3.5 Due Diligence	9
3.6 Intended Use	9
3.7 Foreseeable Misuse	10
4 Introduction	11
5 Mechanical Installation	12
5.1 Cooling	12
5.2 Mounting	12
6 Electrical Installation	14
6.1 Earth (Grounding) Requirements	14
6.2 Overview	15
6.3 Installation Procedure	16
7 Troubleshooting	17
8 Specifications	18
8.1 Nameplate	18
8.2 Input	18
8.3 Output	19
8.4 Control and Signalling	20
8.5 LEDs	21

8.6 Environment	22
8.7 Connections	22
8.7.1 Input Connection X1	22
8.7.2 Output Connection X2	22
8.7.3 Signal Connection X3	23
8.7.4 CAN-Bus Connection X4	23
8.8 CAN-Bus Interface	24
8.9 Mechanical Data	24
8.10 Dimensions	25
8.10.1 Front View	25
8.10.2 Side View	26
9 Appendix	27
9.1 Glossary	27
Index	30

1 General Information

1.1 Important Safety Warnings

⚠ WARNING

HIGH VOLTAGE

The ISD 410 servo system contains components which operate at a high voltage when connected to the electrical supply network. A hazardous voltage is present on the servomotors, the power supply module and the connection box whenever they are connected to the mains network. There are no indicators on the servomotor that indicate the presence of mains voltage. This indication is provided on the connection box. Installation, commissioning and maintenance may only be performed by qualified staff. Incorrect installation, commissioning or maintenance can lead to death or serious injury.

⚠ WARNING

UNINTENDED START

The ISD 410 servo system contains servomotors which are connected to the electrical supply network and can start running at any time. This may be caused by an external switch, a CAN bus command, a reference signal, or clearing a fault condition. Servomotors and all connected devices must be in good operating condition. A deficient operating condition may lead to death, serious injury, damage to equipment or other material damage when the unit is connected to the electrical supply network. Take suitable measures to prevent unintended starts.

⚠ WARNING

DISCHARGE TIME

The servomotors, the connection box and the power supply module contain DC link capacitors, that remain charged for some time after the mains supply is switched off at the power supply module.

To avoid electrical shock, fully disconnect the power supply module from the mains before carrying out any maintenance on the ISD servo system or its components. Wait for at least the time listed below before carrying out maintenance work:

Number	Minimum waiting time (discharge time)
1-60 servomotors	10 minutes
Note: High voltage may still be present even if the LED on the ISD connection box is not lit!	

Table 1.1 Discharge Time

1.2 Copyright

Disclosure, duplication and sale of this document, as well as communication of its content, are prohibited unless explicitly permitted. Infringement of this prohibition incurs liability for damages. All rights reserved with regard to patents, utility patents and registered designs. ISD is a registered trademark.

1.3 Product Names and Trademarks

VLT® and ISD® are registered trademarks of Danfoss. All other product names and trademarks used in this documentation are trademarks or registered trademarks of their respective titleholders.

1.4 Disclaimer

No liability is assumed for any damage or breakdown resulting from:

- Failure to observe the information in the instruction manuals
- Unauthorised modifications to the ISD servo system or its components
- Operator error
- Improper work on or with the ISD servo system or its components.

1.5 Approvals

1.5.1 ISD 410 Servomotor, ISD Encoder Box and ISD Connection Box

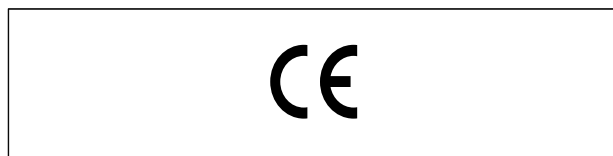

Table 1.2 Approvals for the ISD 410 Servomotor, ISD Encoder Box and ISD Connection Box

1.5.2 ISD Power Supply Module



Table 1.3 Approvals for the ISD Power Supply Module

1.6 Service and Support

Contact your local service representative for service and support:

www.danfoss.com/Contact/Worldwide/

2 Introduction

2.1 System Overview

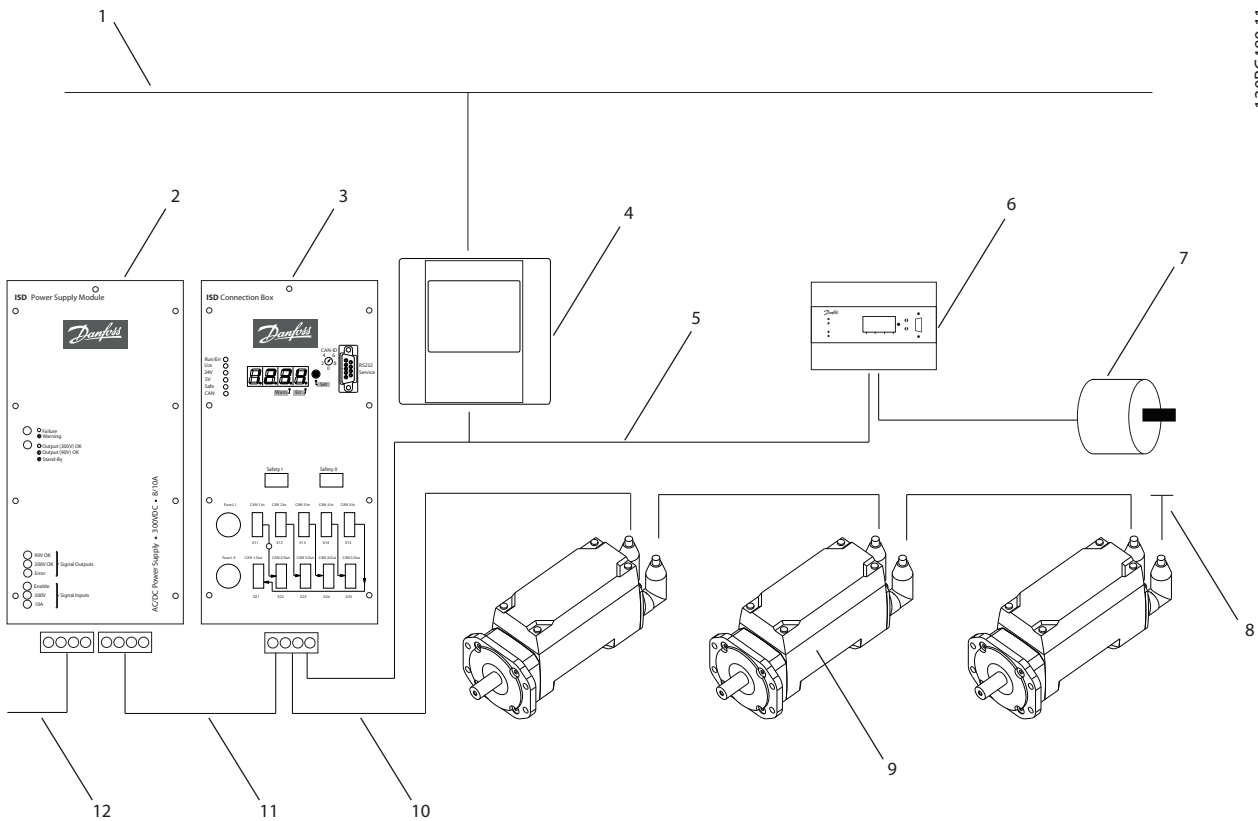

130BC480.11

Illustration 2.1 ISD Servo System with 3 Servomotors

Number	Description	Number	Description
1	Ethernet	7	Master encoder
2	Power supply module	8	Terminating resistor
3	Connection box	9	ISD servomotor
4	Master	10	Hybrid cable (DC & CAN)
5	CAN line	11	DC line
6	Encoder box	12	AC line

Table 2.1 Legend to Illustration 2.1

The servomotors are self-contained distributed drives, which means that the drive electronics is housed together with the motor in the same casing. The motion control software also runs independently in the servomotor; which reduces the load on the higher-level control system.

A master system controls the servomotors. In this system servomotors operated in a DC group are controlled by a master system.

Several motors can be operated in a group using a hybrid cable. This cable carries the DC supply voltage and the CAN bus signals. The ISD 410 servo system is designed to accommodate up to 60 ISD 410 servomotors and consists of:

- 1 Power supply module
- 1 Connection box
- 1 Encoder Box
- Servomotors
- 1 Master
- Hybrid cables

NOTE

**The ISD 410 servomotors cannot be used in other servo systems from other manufacturers!
Motors from other manufacturers cannot be used in the Danfoss ISD 410 servo system!**

2.2 Terminology

ISD	Integrated Servo Drives
ISD servo system	Complete system including all components.
ISD master	Control system hardware
ISD master system	Control system hardware and software
ISD servo drive	ISD servomotor with hybrid cable

Table 2.2 Terminology

2.3 Purpose of the Operating Instructions

The purpose of these operating instructions is to describe the Danfoss ISD power supply module exclusively in the context of a Danfoss ISD 410 servo system.

These operating instructions contain information about:

- Installation
- Commissioning
- Operation
- Troubleshooting
- Maintenance and repair

These operating instructions are intended for use by qualified personnel. Read these operating instructions in full in order to use the servo system safely and professionally, and pay particular attention to the safety instructions and general warnings. These operating instructions are an integral part of the ISD power supply module. Keep these operating instructions available with the servo system at all times.

Compliance with the information in the operating instructions is a prerequisite for:

- Trouble-free operation
- Recognition of product liability claims

Therefore, read these operating instructions before working with the power supply module!

The operating instructions also contain important service information. The operating instructions should therefore be kept close to the power supply module.

2.4 Additional Resources

Available documents for the ISD 410 servo system:

Document	Contents
VLT® ISD 410 Servomotor Operating Instructions	Information about the commissioning and operation of the servomotors
VLT® ISD Encoder Box Operating Instructions	Information about the commissioning and operation of the encoder box
VLT® ISD Connection Box Operating Instructions	Information about the commissioning and operation of the connection box
VLT® ISD Power Supply Module Operating Instructions	Information about the commissioning and operation of the power supply module
VLT® ISD 410 Design Guide	Information about the construction and commissioning of the ISD 410 servo system

Table 2.3 Available Documents for the ISD 410 Servo System

Technical literature for Danfoss drives is also available online at <http://www.danfoss.com/BusinessAreas/DrivesSolutions/Documentations/Technical+Documentation.htm>.

Firmware updates may be available. When firmware updates are available, they can be downloaded from the www.danfoss.com website. For further information see the *VLT® ISD 410 Design Guide*.

3 Safety

3.1 Symbols used in this Manual

The following symbols are used in this document.

⚠ WARNING

Indicates a potentially hazardous situation which, if not avoided, could result in death or serious injury.

⚠ CAUTION

Indicates a potentially hazardous situation which, if not avoided, may result in minor or moderate injury. It may also be used to alert against unsafe practices.

CAUTION

Indicates a situation that may result in equipment or property-damage-only accidents.

NOTE

Indicates highlighted information that should be regarded with attention to avoid mistakes or operate equipment at less than optimal performance.

3.2 General

The following safety instructions and precautions relate to the ISD 410 servo system. The number of servomotors in the servo system is not significant.

Read the safety instructions carefully before starting to work in any way with the servo system.

Pay particular attention to the safety instructions in the relevant sections of this instruction manual.

Also observe the safety instructions and precautions in the instruction manuals for the other system components.

⚠ WARNING

HIGH VOLTAGE

The ISD 410 servo system contains components which operate at a high voltage when connected to the electrical supply network.

A hazardous voltage is present on the servomotors, the power supply module and the connection box whenever they are connected to the mains network.

There are no indicators on the servomotor that indicate the presence of mains voltage. This indication is provided at the connection box. Installation, commissioning and maintenance may only be performed by qualified staff. Incorrect installation, commissioning or maintenance can lead to death or serious injury.

⚠ WARNING

HAZARDOUS SITUATION

If the servomotor or the bus lines is/are incorrectly connected, there is a risk of death, serious injury or damage to the unit.

Always comply with the instructions within these operating instructions, as well as national and local safety regulations. Also read the operating instructions for the other components of the servo system.

3.3 Safety Instructions and Precautions for the ISD 410 Servo System

Read the safety instructions carefully before starting to work in any way with the servo system. Compliance with the safety instructions and precautions is necessary at all times.

- Orderly and proper transport, storage, fitting and installation, as well as careful operation and maintenance, are essential for the trouble-free and safe operation of this servo system and its components.
- Only suitably trained and qualified staff may work on the servo system and its components or in its vicinity. See chapter 3.4 *Qualified Personnel*.
- Use only accessories and spare parts approved by the manufacturer.
- Comply with the specified ambient conditions.
- The information in these operating instructions about the use of available components is provided solely by way of examples of applications and suggestions.
- The plant engineer or system engineer is personally responsible for checking the suitability of the supplied components and the information provided in this document for the specific application concerned:
 - for compliance with the safety regulations and standards relevant to the specific application concerned.
 - for implementing the necessary measures, changes and extensions.
- Commissioning the servo system and its components is not allowed until it has been ascertained that the machine, system or plant in which they are installed conforms to the statutory provisions, safety regulations and standards that apply in the country of use to that application.

- Operation is allowed only in compliance with the national EMC regulations for the application concerned.
- See the *VLT® ISD 410 Design Guide* for information regarding EMC-compliant installation of the servo system.
- Compliance with the limit values specified by national regulations is the responsibility of the producer of the plant, system or machine.
- Compliance with the specifications, connection conditions and installation conditions in this instruction manual is mandatory.
- The safety regulations and safety provisions of the country in which the equipment is used must be observed.
- Care must be taken to ensure that orderly protective earthing of the equipment, which protects the user against the supply voltage and protects the power supply module against overload, is performed in accordance with local and national regulations.
- Overload protection for the servomotor can be programmed using the master system. For more information, see *Programming* in the *VLT® ISD 410 Design Guide*.
- Do not remove or replace the SD card on the encoder box during operation, otherwise the contents of the SD card could be destroyed. Switch the encoder box off and wait 10 seconds before removing the SD card.

⚠ WARNING

EARTHING HAZARD

For reasons of operator safety, the components of the servo system must be earthed correctly in accordance with national or local electrical regulations and the information in these operating instructions. The earth leakage current is greater than 3.5 mA. Improper earthing of the servomotor may result in death or serious injury.

Operational Safety

- Safety-related applications are allowed only if they are explicitly and unambiguously mentioned in the *VLT® ISD 410 Design Guide*. Otherwise they are not allowed.
- All applications that can cause hazards to people or damage to property are safety-related applications.
- The stop functions implemented in the software of the master system do not interrupt the mains voltage supply to the power supply module and are therefore not allowed to be used as safety switches for the servo system.
- The motor can be brought to a stop by a software command or a zero speed setpoint, but DC voltage remains present on the servomotor and/or mains voltage in the power supply module. If personal safety considerations (e.g. risk of personal injury caused by contact with moving machine parts after an unintended start) make it necessary to ensure that an unintended start cannot occur, these stop functions are not sufficient. In this case the servo system must be detached from the mains network or a suitable stop function must be implemented.
- When the servomotor is stopped, it may start up again on its own if the circuitry of the servomotor is defective or after the elimination of a temporary overload, a problem with the supply voltage or a problem with the servomotor. If personal safety considerations (e.g. risk of personal injury caused by contact with moving machine parts after an unintentional start) make it necessary to ensure that an unintended start cannot occur, the normal stop functions of the servomotor are not sufficient. In this case the servo system must be disconnected from the mains network or a suitable stop function must be implemented.
- The servomotor may start running unintentionally during parameter configuration or programming. If this can pose a risk to personal safety (e.g. risk of personal injury due to contact with moving machine parts), unintended motor starting must be prevented, for example by using the Safe Stop function or by safe disconnection of the servomotors.
- Do not disconnect the cables from the servomotor while the servo system is connected to mains voltage. Ensure that the mains supply is disconnected and the required waiting time has elapsed before disconnecting or connecting the hybrid cable or disconnecting cables from the connection box and/or the power supply module.

- In addition to the L1, L2 and L3 supply voltage inputs on the power supply module, the servo system has other supply voltage inputs, including external DC 24 V. Before commencing repair work, check that all supply voltage inputs have been switched off and that the necessary discharge time for the intermediate circuit capacitors has elapsed.
- The supply of power to the servo system must be switched off for repair work. Before disconnecting or connecting the hybrid cable or disconnecting cables from the connection box and/or the power supply module, ensure that the mains supply is disconnected and the necessary discharge time has elapsed.

⚠ WARNING

DISCHARGE TIME

The servomotors, the connection box and the power supply module contain DC link capacitors, that remain charged for some time after the mains supply is switched off at the power supply module.

To avoid electrical shock, fully disconnect the power supply module from the mains before carrying out any maintenance on the ISD servo system or its components. Wait for at least the time listed below before carrying out maintenance work:

Number	Minimum waiting time (discharge time)
1-60 servomotors	10 minutes
Note: High voltage may still be present even if the LED on the ISD connection box is not lit!	

Table 3.1 Discharge Time

CAUTION

Never connect or disconnect the hybrid cable to or from the servomotor when voltage is present. Doing so will damage the electronic circuitry. Observe the discharge time for the DC link capacitors.

3.4 Qualified Personnel

Installation, commissioning and maintenance of the ISD 410 servo system may only be carried out by qualified personnel.

For the purposes of this document and the safety instructions in this document, qualified staff are trained staff who are authorised to fit, install, commission, earth and label equipment, systems and circuits in accordance with the standards for safety technology and who are familiar with the safety concepts of automation engineering.

Additionally, the personnel must be familiar with all the instructions and safety measures described in these operating instructions. They must have suitable safety equipment and be trained in first aid.

3.5 Due Diligence

The operator and/or fabricator must ensure that:

- the servo system and its components are used only as intended
- the components are operated only in a perfect operational condition
- the operating instructions are always available near the servo system in complete and readable form
- the servo system and its components are fitted, installed, commissioned and maintained only by adequately qualified and authorised personnel
- these personnel are regularly instructed on all relevant matters of occupational safety and environmental protection, as well as the contents of the operating instructions and in particular the instructions it contains
- the product markings and identification markings applied to the components, as well as safety and warning instructions, are not removed and are always kept in a legible condition
- the national and international regulations regarding the control of machinery and equipment, that are applicable at the place of use of the servo system, are complied with
- the users always have all current information relevant to their interests about the servo system and its use and operation

3.6 Intended Use

The components of the ISD servo system are intended to be installed in machines used in commercial and industrial environments.

To ensure that the product is used as intended, the following conditions must be fulfilled before use:

- Everyone who uses Danfoss products in any manner must read and understand the corresponding safety regulations and the description of the intended use
- Hardware must be left in its original state, which means that no structural changes may be made to the hardware

- Software products may not be reverse-engineered and their source code may not be altered
- Damaged or faulty products may not be installed or put into service
- It must be ensured that the products are installed in conformance with the regulations mentioned in the documentation
- Any specified maintenance and service intervals must be observed
- All protective measures must be complied with
- Only the components described in these operating instructions may be fitted or installed. Third-party devices and equipment may be used only in consultation with Danfoss
- The documentation must be read completely and correctly followed

The servo system **may not** be used in the following application areas:

- Areas with potentially explosive atmospheres
- Mobile or portable systems
- Floating or airborne systems
- Inhabited facilities
- Sites where radioactive materials are present
- Areas with extreme temperature variations or in which the maximum rated temperatures may be exceeded
- Under water

3.7 Foreseeable Misuse

Any use not expressly approved by Danfoss constitutes misuse. This also applies to failure to comply with the specified operating conditions and applications.

Danfoss assumes no liability of any sort for damage attributable to improper use.

4 Introduction

The power supply module delivers the required DC 300 V power supply to the ISD servo system. The DC 300 V power supply is delivered to all servo drives installed in the system via a hybrid cable. It is a controlled power supply module, whereby the maximum rated output current is 10 A, and the rated power is 3.0 kW. The LEDs on the front of the unit display the operating status and warnings.

CAUTION

The power supply module has an IP-rating of IP20. It is only designed for use within a control cabinet. The unit may be damaged if exposed to fluids.

5 Mechanical Installation

5.1 Cooling

NOTE

- To provide cooling airflow, mount the unit to a solid flat surface or to the optional back plate.
- Top and bottom clearance for air cooling must be provided. Generally, 100-225 mm is required.
- Improper mounting can result in over-heating and reduced performance.

5.2 Mounting

- Mount the unit vertically.
- Ensure that the strength of the mounting location will support the unit weight.
- Mount the unit to a solid flat surface to provide cooling airflow.
- Improper mounting can result in over heating and reduced performance.
- Use the slotted mounting holes on the unit for wall mounting.

Mount the power supply module in the control cabinet according to the following graphic.

- All dimensions are in mm.
- Recommended screws: Cylinder-head screw M5

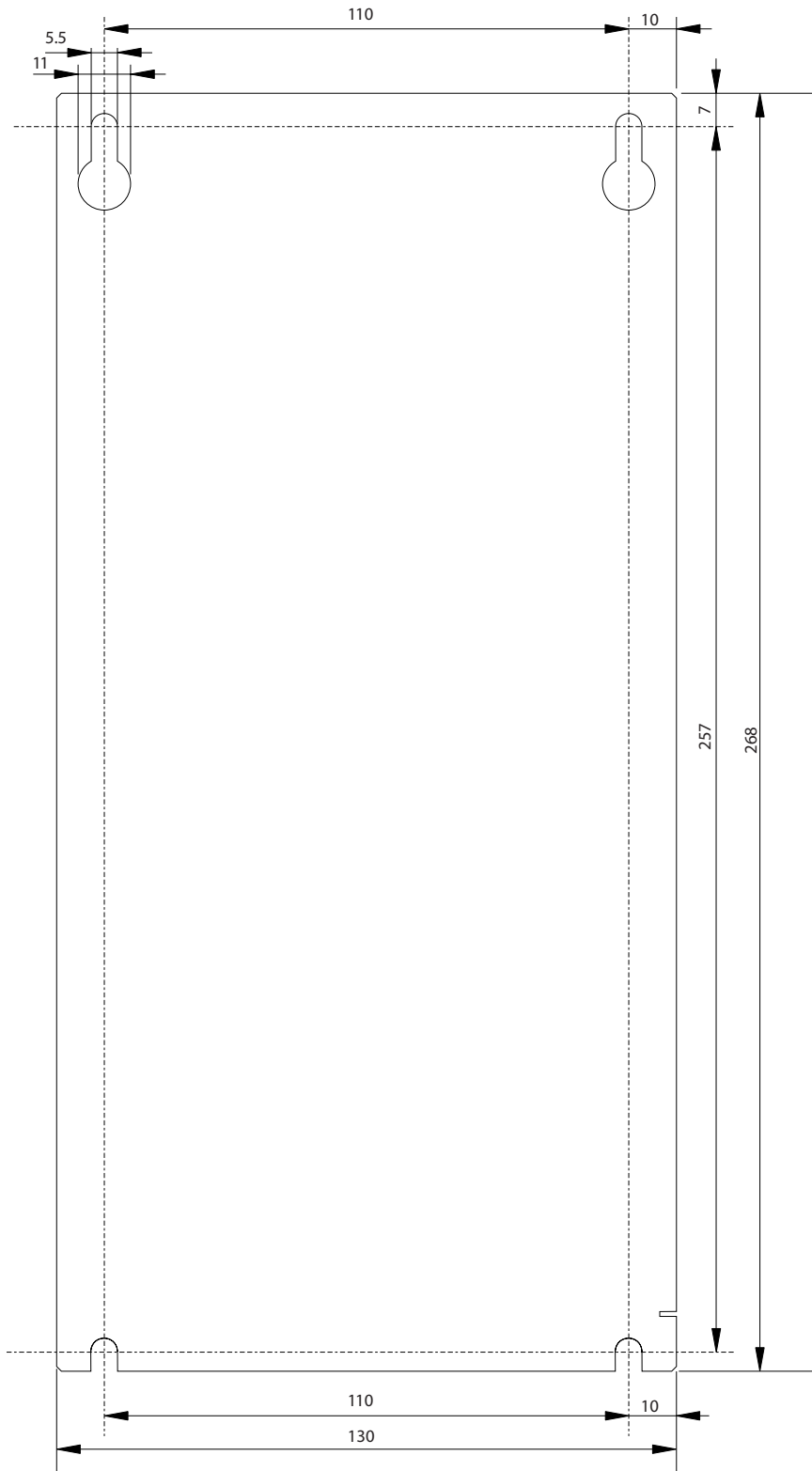

130BD041.10

5

Illustration 5.1 Dimensions

6 Electrical Installation

6.1 Earth (Grounding) Requirements

⚠ WARNING**GROUNDING HAZARD!**

For operator safety, it is important to ground the power supply module properly in accordance with national and local electrical codes as well as instructions contained within these operating instructions. Ground currents are higher than 3.5 mA. Failure to ground the power supply module properly could result in death or serious injury.

6

6.2 Overview

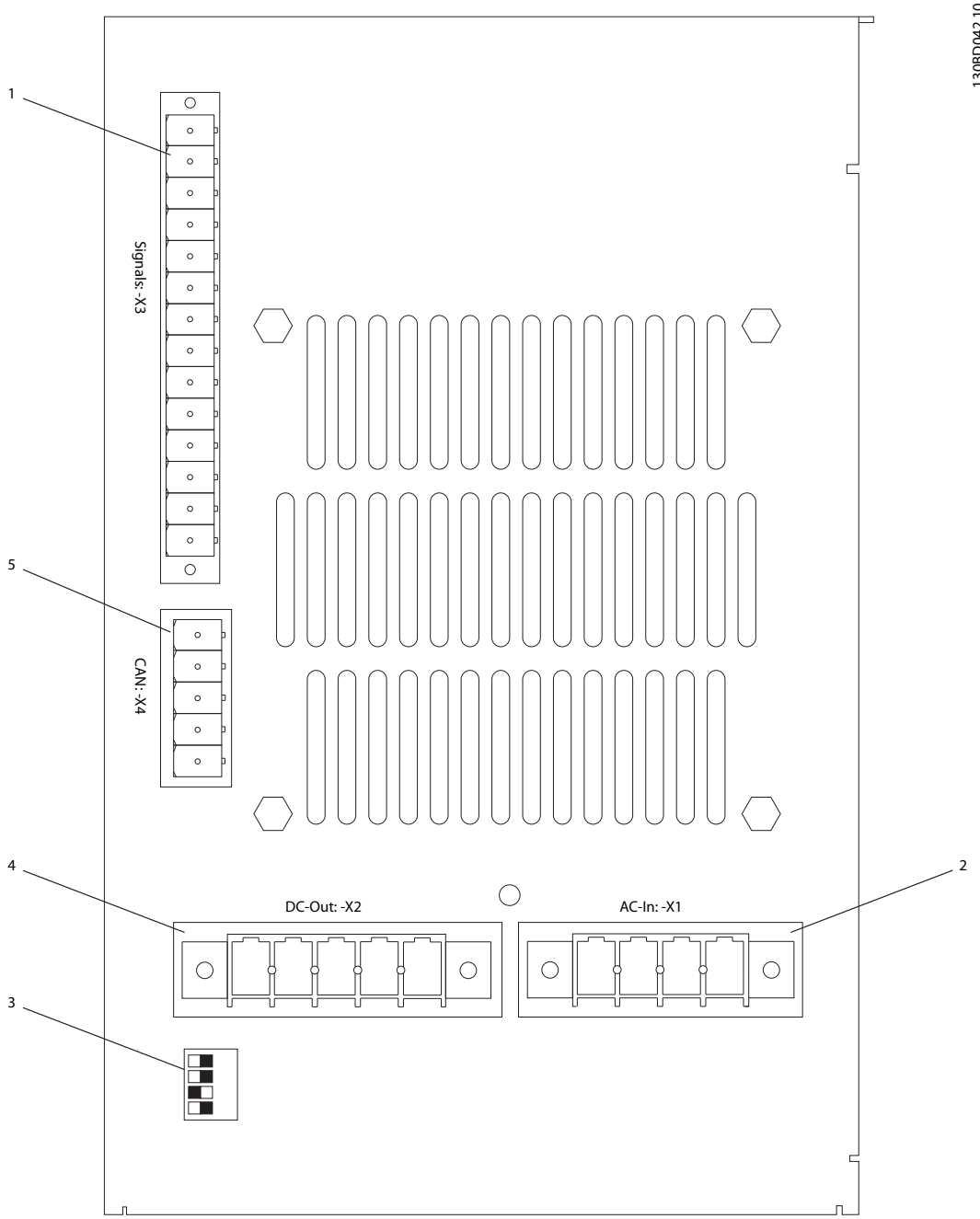

Illustration 6.1 Connections

1	Signal plug X3
2	Power input plug AC-In X1
3	CAN dip switch
4	Power output plug DC-Out X2
5	CAN bus plug X4

Table 6.1 Legend to Illustration 6.1

6.3 Installation Procedure

⚠ WARNING

HIGH VOLTAGE!

The power supply module contains high voltage when connected to AC mains input power. Installation, start up, and maintenance should be performed by qualified personnel only. Failure to perform installation, start up, and maintenance by qualified personnel could result in death or serious injury.

⚠ WARNING

INCORRECT VOLTAGE!

Connecting the incorrect voltage to the power supply module can result in death or serious injury and damage to the unit.

- Only connect voltages of AC 400-480 V, 50/60 Hz, 3-phase and PE.
- Only TN mains are allowed.

1. Wire and connect the power input plug to "AC-In: -X1"

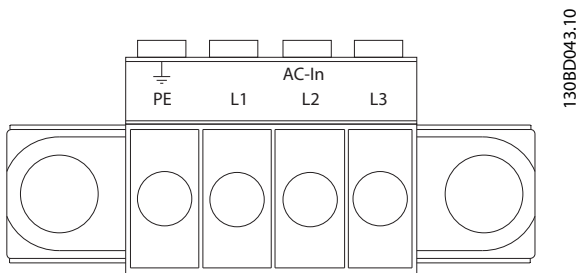

Illustration 6.2 Power Input Plug

2. Wire and connect the power output plug to "DC-Out: -X2"

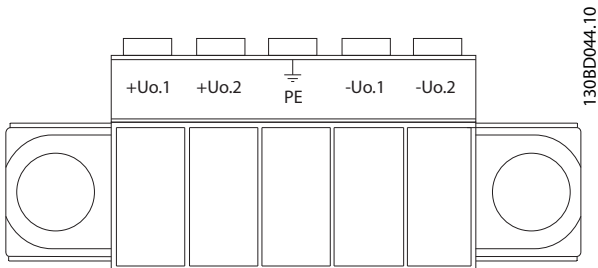

Illustration 6.3 Power Output Plug

3. Wire and connect the signal plug to "Signals: -X3" to enable the hardware. The pin assignment is detailed in chapter 8.7.3 Signal Connection X3.

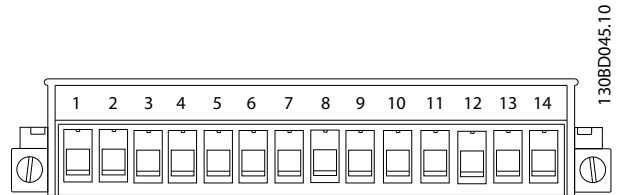

Illustration 6.4 Signal Plug

4. Wire and connect the CAN bus plug to "CAN: -X4"

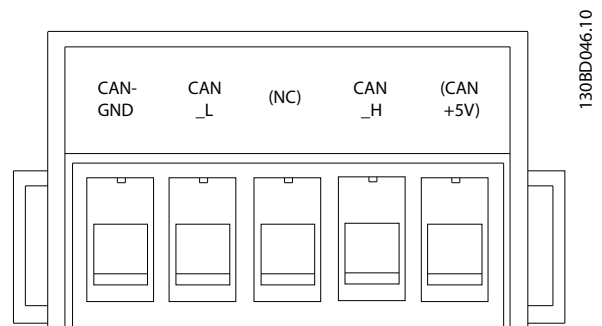

Illustration 6.5 CAN Bus Plug

5. Ensure that the CAN dip switch is set to "500 kbit/s" (default)

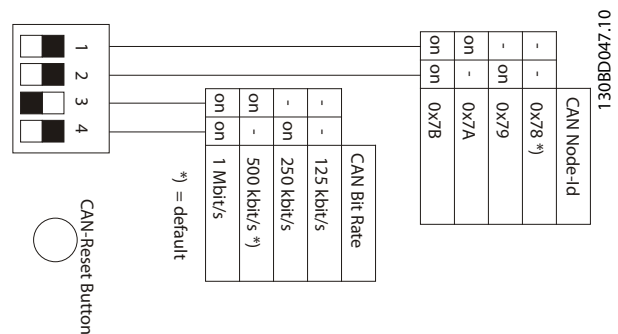

Illustration 6.6 CAN Dip Switch

7 Troubleshooting

LED No.	Indication	Fault	Possible Cause	Measures	Comments
1	Green LED twinkling	No output voltage	Signal input "Enable" not active	Apply 10-28 V to signal input "Enable"	Also possible: connect 12 V auxiliary voltage directly at the signal connector (X3).
2	Green LED blinking	Reduced output voltage	Signal input "300V" not active	Apply 10-28 V to signal input "300 V", if full output voltage (Setpoint U_o nominal) is desired	Also possible: connect 12 V auxiliary voltage directly at the signal connector (X3).
3	No LED active	No output voltage	<ul style="list-style-type: none"> No AC input voltage Phases missing 	Check AC input voltage	If the power supply module's external fuse is blown, there is a failure in the power supply module. Send the power supply module to Danfoss.
4	Red LED blinking	Output voltage possibly reduced	Output current too high	Check if output current is higher than current I_o limitation	–
5	Red LED blinking	Output voltage possibly reduced	<ul style="list-style-type: none"> Fan blocked Fan speed reduced 	<ul style="list-style-type: none"> Check if fan is mechanically locked, e.g. by parts reaching inside the power supply (fan) Send the power supply module to Danfoss for the fan to be replaced 	If the fan is blocked, the output current is automatically limited to 4 A.
6	Red LED blinking	Output voltage possibly reduced	Internal heatsink temperature too high	<ul style="list-style-type: none"> Check if air inlet and outlet are free Check if the ambient temperature is too high 	If the temperature is above "Warning Level", the output current is limited to 4 A.
7	Red LED active	No output voltage	Internal heatsink temperature too high	<ul style="list-style-type: none"> Check if air inlet and outlet are free Check if the ambient temperature is \leq the rated ambient temperature of the specification 	If temperature is above "Fault Level", the output is switched off
8	Red LED active	No output voltage	Internal failure	Contact Danfoss-Service	If the external fuse is broken, do not try to return the mains voltage to the power supply module.

7

Table 7.1 Troubleshooting

8 Specifications

8.1 Nameplate

ISD Power Supply Module

Power Supply BSAB3000-480T-300C-1

1 Input: 380...480VAC, 3PH, 50-60Hz / max. 6A

2 Input Fuses: external fuses 3 x 6.3A required

3 Output: 90 / 300VDC / max. 10A

4 PART NO: 175G7800 SERIAL NO: 000101M212

5

130BD048:10

File: 220234

175G700000101M212

Made in Germany

1	Supply voltage
2	Fuses
3	Output voltage
4	Part number
5	Serial number

Table 8.1 Legend to Illustration 8.1

Illustration 8.1 Nameplate

8

8.2 Input

Definition	Min.	Type	Max.	Unit	Condition	Remark
Rated input voltage range	380	400	480	V _{AC}	3 Phase + PE, 50/60 Hz	+/- 10%
Input current	-	-	6	A _{rms}	-	Each phase
Fuses	External 3-pole line safety switch, 3 x 6.3 A				-	-
Inrush current	-	-	20	A	After 1 ms	-
Holdup time	5	-	-	ms	At P _{o nominal}	Until output < 90% U _{o nominal}
Power factor (P _{active} / P _{apparent})	90	94	-	%	At U _i = AC 400 V; U _o = DC 300 V; I _o = 10 A	-
Line frequency	47	-	63	Hz	-	-

Table 8.2 Input Data

8.3 Output

Definition	Min.	Type	Max.	Unit	Condition	Remark
Output voltage U_o normal	0	300 (default)	300	V _{DC}	–	Reduction possible via CANopen interface
Tolerance, static (incl. line regulation)	0	0	+/-1	%	–	–
Load regulation (0% / 100% nominal current)	0	-1.5 (default)	-7.5	%	–	Adjustable in 16 steps via CANopen interface
Ripple	–	–	1	V _{pp}	BW = 20 MHz	–
Rated power P_o nominal	–	3000	–	W	–	–
Rated current I_o nominal	–	10	–	A	Control input "10 A" active	–
Current limitation "10 A"	10.1	10.2	10.5	A	Control input "10 A" active	–
Current limitation "reduced"	7.5	7.8	7.9	A	–	Control input "10 A" open
Current limitation at "thermal warning level"	3.5	–	4.5	A	–	If fan blocked or heat sink temperature too high
Short circuit rigidity	Yes, continuously				–	–
Efficiency	92	93	–	%	–	–
No load input power	–	15	–	W	–	–
Parallel operation	Up to 3 units				–	Load sharing supported by "downslope" characteristic
Potential conditions	Output is floating				Test voltage > DC 1000 V output against PE	Normally 1 pole of the output will be grounded in the application
Ext. allowed capacity at U_o	0	–	>15	mF	Output stable	–
Over-voltage protection (normal) OVP	305	–	335	V _{DC}	Average value	Non-latching

Table 8.3 Output Data

8.4 Control and Signalling

Definition	Min.	Type	Max.	Unit	Condition	Remark
Signal output "300V_OK" (X3:3)		Optocoupler output			Active if control loop U_o with setpoint $U_{o\ nominal}$ (300 V) is operating	
Signal output "Error" (X3:5)		Optocoupler output			Active on failure (error)	
All optocoupler outputs active	-	-	5	V	At 10 mA	Current limitation with PTC (short-circuit proof up to 28 V)
All optocoupler outputs inactive	-	-	0.1	mA	At max. 35 V	-
Signal input "Enable" (X3:7)		Optocoupler input			<ul style="list-style-type: none"> • Output switched on when active • Output switched off (standby) when inactive 	
Signal input "300V" (X3:9)		Optocoupler input			<ul style="list-style-type: none"> • Setpoint $U_{o\ nominal}$ (300 V) when active • Setpoint $U_{o\ reduced}$ (90 V) when inactive 	Redundant internal circuit ensures $U_o < 102$ V also in case of a single internal component fault
Signal input "10A", output current limitation limitation setting		Optocoupler input			<ul style="list-style-type: none"> • Setpoint $I_{o\ limited\ nominal}$ (10.2 A) when active • Setpoint $I_{o\ limited\ reduced}$ (7.8 A) when inactive 	
All optocoupler inputs active	10	-	28	V	max. 10 mA	-
All optocoupler inputs inactive	-	-	5	V	-	-
Current on auxiliary output 12 V (X3:13, X3:14)	-	-	10	mA	Sufficient for supplying the 3 signal inputs	

Table 8.4 Control and Signalling

8.5 LEDs

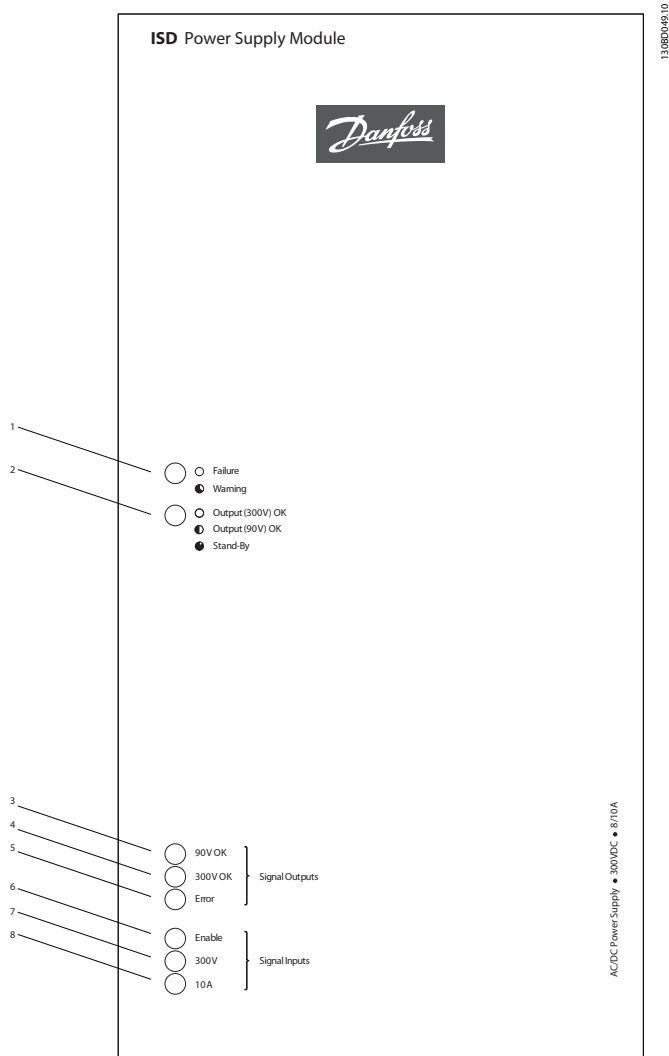

8

Illustration 8.2 LEDs

LED	Definition	Type	Condition	Remark
1	Failure signalling	Red LED on front of module	<ul style="list-style-type: none"> Continuously on during failure (output is switched off) Blinking at warning level (e.g. fan at too low speed, current limit active, heatsink temperature reached first limit, input voltage too low etc.) 	
2	OK signalling	Green LED on front of module	<ul style="list-style-type: none"> Continuously on if output voltage U_o at U_o nominal (300 V) and ok 50 % blinking if U_o at U_o reduced (90 V) and ok Twinkling during standby 	
3-5	Signalling of all optocoupler outputs	Orange LED for each on front of module	-	LED on when active
6-8	Signalling of all optocoupler inputs	Orange LED for each on front of module	-	LED on when active

Table 8.5 Legend to Illustration 8.2

8.6 Environment

Definition	Min.	Type	Max.	Unit	Condition	Remark
Ambient temperature	0	-	+50	°C	Without derating	At +70 °C derating to 50% I _o (in range +50 to 70 °C linear declining)
Humidity	-	-	95	%	Non-condensing	-
Cooling	Internal fan, temperature controlled				Air flow from bottom to top. Do not block air intake and allow 100-255 mm air cooling space at top and bottom of unit.	
Protection category	IP20				Standard	
Protection class	1 (with PE-connection)				-	-
Designed according to safety standards	CSA C22.2 No. 60950-1:2003 and UL60950-1:2003 and/or IEC 60950-1:2001 (1st Edition) and/or EN 60950-1:2001 and/or DIN/EN 60950-1:2003 and EN 60950-1 second edition 2006 UL508:2005 and CSA22.2-107. EN 60204:1998					
Approvals	CE, CSA					

Table 8.6 Environmental Data

8

8.7 Connections

8.7.1 Input Connection X1

4-pole (coded) Phoenix PCV 4 / 5-G-7.62 with mating plug (included) PC 5 / 4-STF-7.62 (gauge up to 6 mm²)

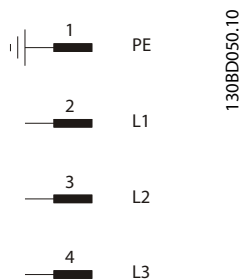

Illustration 8.3 Input Connection X1

8.7.2 Output Connection X2

5-pole, can also be used for looping through (max. 20 A). Phoenix PCV 4 / 5-G-7.62 with mating plug (included) PC 5 / 5-STF-7.62 (gauge up to 6 mm²)

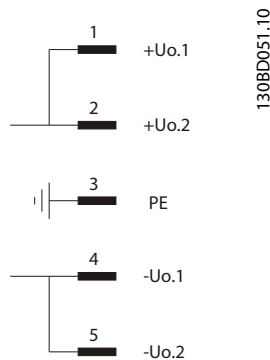

Illustration 8.4 Input Connection X2

8.7.3 Signal Connection X3

14-pole Phoenix MSTB 2.5 / 14-GF-5.08 with mating plug (included) MSTB 2.5 / 14-STF-5.08

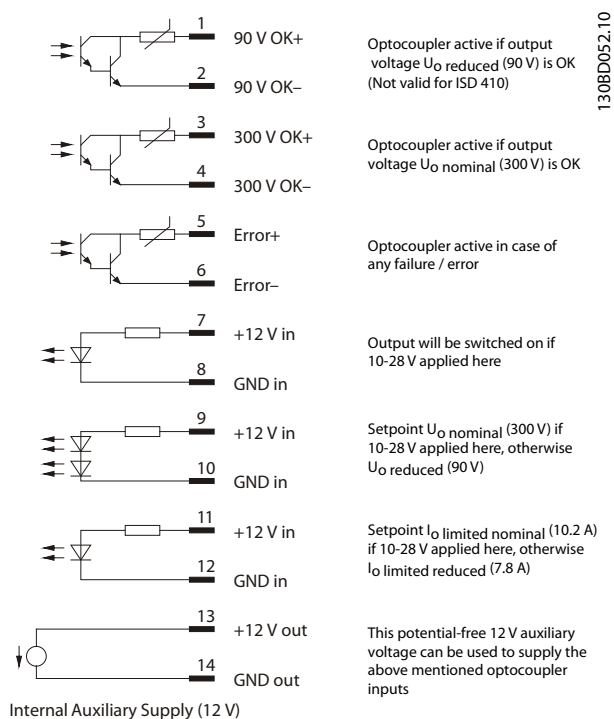

Illustration 8.5 Signal Connection X3

Here is an example of how to wire signal plug X3 in order to enable the hardware:

- Pin 13 to 11 to 9 to 7
- Pin 14 to 12 to 10 to 8

⚠ WARNING

HIGH VOLTAGE!

By using the above detailed wiring example the DC 300 V output voltage is immediately available once the AC 400 V supply voltage is connected.

Use a relay between pins 9 and 7 to control the output voltage. The DC 300 V output voltage is enabled when the relay is closed.

8.7.4 CAN-Bus Connection X4

5-pole Phoenix MSTBA 2.5 / 5-G-5.08 with mating plug (included) MSTB 2.5 / 5-ST-5.08

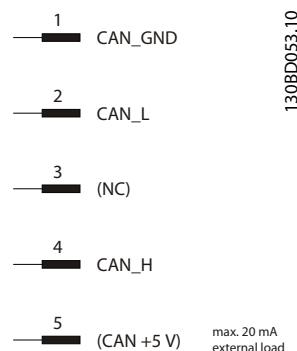

Illustration 8.6 CAN-Bus Connection X4

8.8 CAN-Bus Interface

The CAN DIP-switch is located in the underside of the power supply module.

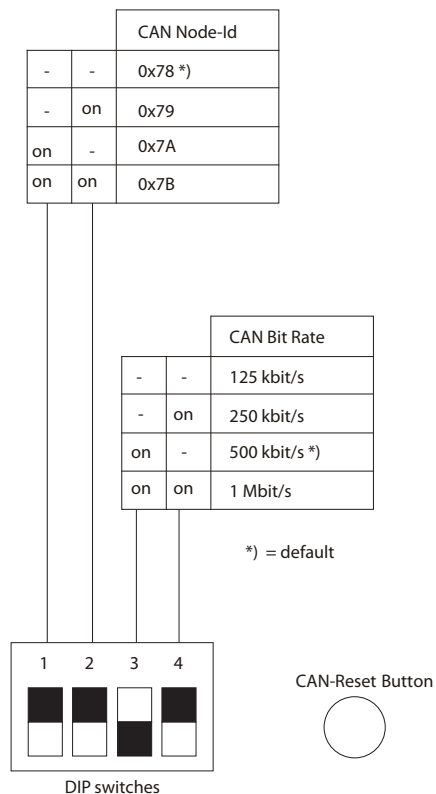

Illustration 8.7 CAN DIP-Switch

Definition	Description	Condition
Potential relation	CAN-Bus is insulated	Test voltage DC 500 V CAN against PE
CAN-Baud rate	125, 250, 500 (default), 1000 kbit/s	Switchable via 2 DIP-switches
CAN-ID	0x78 (default), 0x79, 0x7A, 0x7B	Switchable via 2 DIP-switches
Protocol	CANopen (specified by CAN in Automation CiA)	According to CiA 401 "Generic I/O"

Table 8.7 CAN-Bus Interface Data

8.9 Mechanical Data

Housing	Steel and aluminium for wall mounting
Dimensions (H x W x D)	Approx. 268 x 130 x 205 mm
Weight	5.5 kg
Mounting	On rear side
Connector arrangement	On underside

Table 8.8 Mechanical Data

8.10 Dimensions

8.10.1 Front View

All dimensions are in mm.

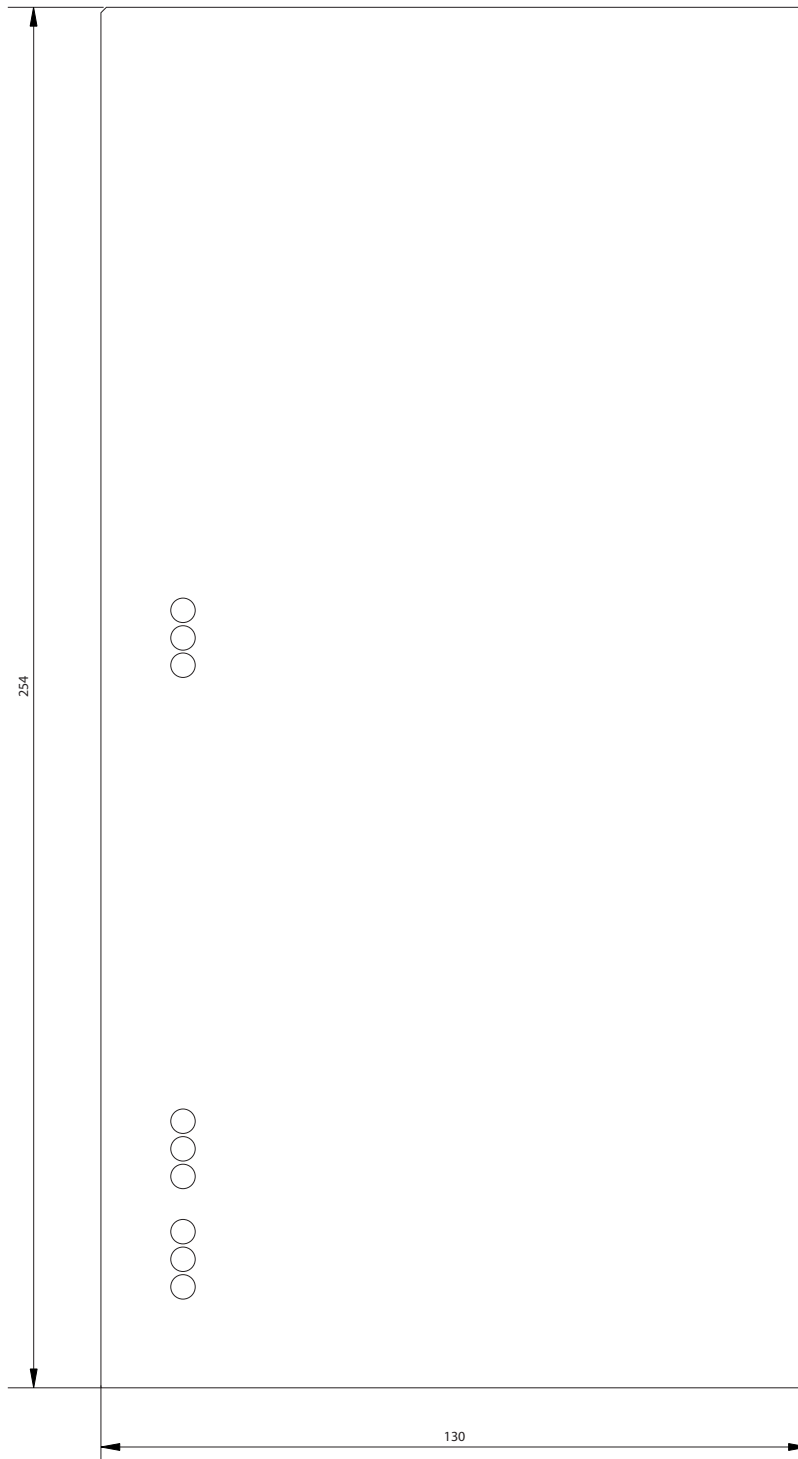

Illustration 8.8 Front View

8.10.2 Side View

All dimensions are in mm.

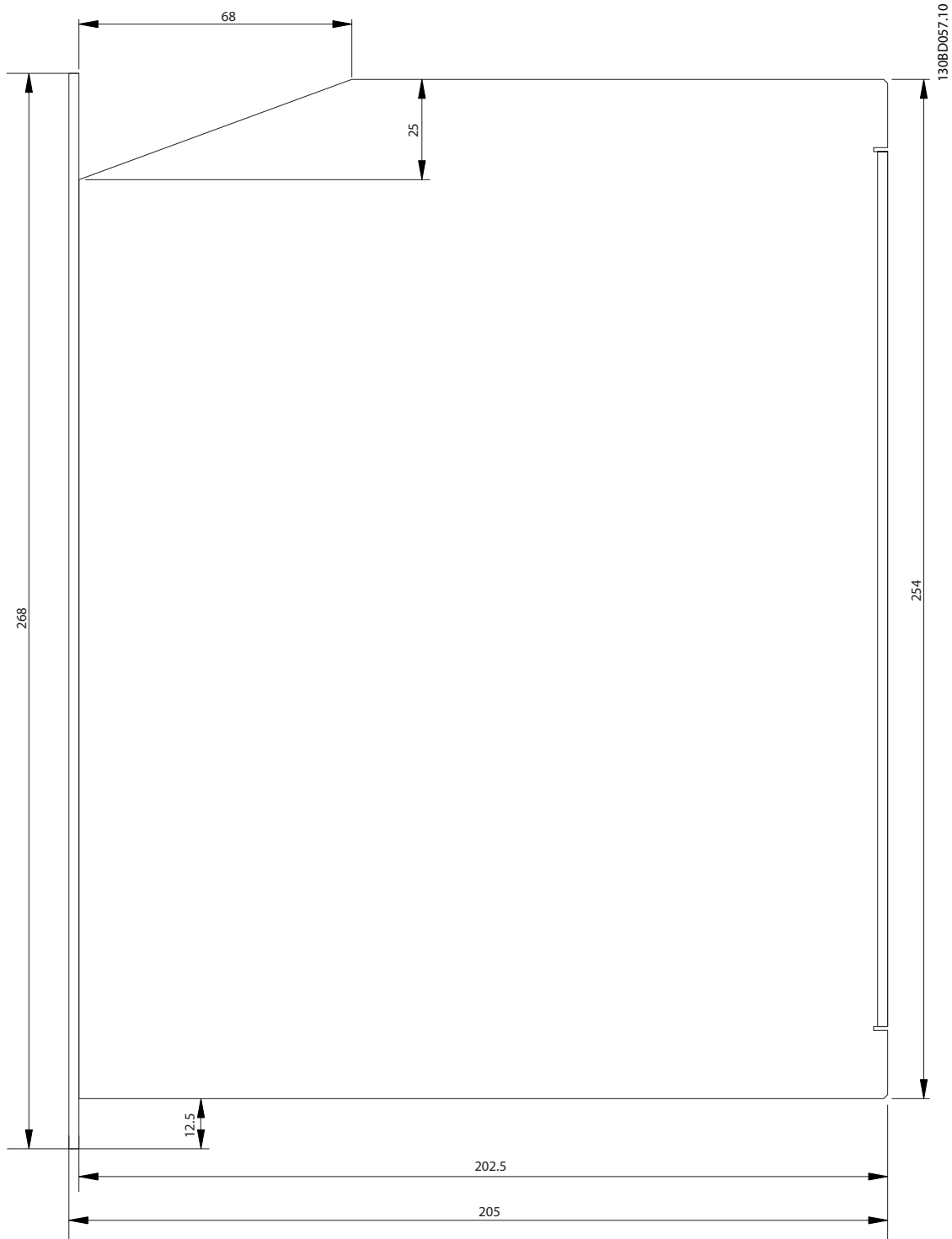

Illustration 8.9 Side View

8

9 Appendix

9.1 Glossary

A flange

The A side is the shaft side of the motor.

Ambient temperature

The temperature in the immediate vicinity of the servo system or component.

Axial force

The force in newton-metres acting on the rotor axis in the axial direction.

BCD

Binary-coded decimal

Bearings

The ball bearings of the servo drive.

B flange

The rear side of the servomotor with the plug-and-socket connectors.

BiSS

Bi-directional Synchronous Serial

Brake

Power-off brake of the ISD servomotor, on the A side of the motor.

CAN

Controller Area Network

CANopen DS301

A standard that specifies the application layer and communication profile.

CANopen DS402

An object-based CAN standard that specifies the device profile for drives and motion control.

CANopen DS406

An object-based CAN standard that specifies the device profile for encoders.

CE

European test and certification mark.

Clamping set

A mechanical device, which, for example, can be used to secure gears to a motor shaft.

CoDeSys

Controller Development System; a development environment for programming controller applications, based on IEC 61131-3 and developed by 3S-Smart Software Solutions GmbH.

Connection box

The connection box provides the link between the power supply module and the servo drives.

Connector (M23)

Servomotor connector.

Cooling

ISD servo drives are cooled by convection, which means without fans.

CRC

Cyclic Redundancy Check

CSA

Canadian test and certification mark.

DC link

Each servomotor has its own DC link, consisting of capacitors.

DC link voltage

A DC voltage shared by several ISD servomotors connected in parallel.

DC voltage

A direct constant voltage.

DSP

Digital signal processor; processor IC on an ISD control board.

Encoder box

The encoder box allows external encoder signals to be sent to the servo drives over the CAN bus with high precision.

Feed cable

Hybrid connection cable between connection box and servomotor, with a connector.

Feedback system

Feedback systems for servomotors in general.

Fieldbus

Communication bus between controller and servo axis; in general between controller and field nodes.

Firmware

Software in the unit; runs on the control board.

Flash

Memory IC on the ISD control board; a form of EPROM.

Function block

Device functionalities are accessible via CoDeSys.

Gear ratio

The speed ratio of the input pinion and the output shaft of the gear unit.

Gear unit

External gear unit used to change the output shaft speed and the torque on the motor shaft.

Hole circle

The hole patterns of the ISD and IEC flanges.

IEC flange

Industry-standard flange

Installation elevation

Installation elevation above normal sea level, typically associated with a derating factor.

ISD

Integrated servo drive, integrated servomotor solution.

ISD flange

The standard flange for ISD servo drives; larger than the IEC flange.

ISD servomotor

Designates the ISD servomotor with hybrid cable.

Loop cable

Hybrid connection cable between two servomotors, with two connectors.

M12 connector

Input connector for connecting the sensor on the B side of the servomotor.

Motor shaft

Rotating shaft on the A side of the servomotor, typically without a key groove.

Multi-turn encoder

Describes a digital absolute encoder, in which the absolute position remains known after several revolutions.

NMT

Network Management

PELV

Low-voltage directive regarding voltage levels and distances between lines.

PDO

Process Data Object (see CANopen DS301).

Planetary gear

A specific type of gearing, typically used with servomotors.

Power-off principle

The brake is normally engaged. It is released by applying a voltage (safety function).

Power supply module

The power supply module provides a regulated DC 300 V from AC 400 V.

QEP

Quadrature Encoder Pulse

Radial force

The force in newton-metres acting at 90° to the longitudinal direction of the rotor axis.

Resolver

A feedback device for servomotors, typically with two analog tracks (sine and cosine).

Safety (STO)

A servomotor safety circuit that switches off the voltages of the driver components for the IGBTs.

Scope

Used for diagnosis. Enables internal signals to be depicted.

SD Card

Secure Digital Card for encoder box.

SDO

Service Data Object (see CANopen DS301).

Segment

A segment refers to a movement within a curve.

SIL 2

Safety Integrated Level II.

Single-turn encoder

Describes a digital absolute encoder, in which the absolute position for one revolution remains known.

SSI

Synchronous Serial Interface

Toolbox

A software tool used for parameter setting and diagnostics of ISD servomotors, the ISD connection box and the ISD encoder box.

Index

A
Approvals..... 3

C
Cooling..... 12

D
Discharge Time..... 3
Documents..... 6
Due Diligence..... 9

E
Earth Requirements..... 14
Electrical Installation..... 15

F
Forseeable Misuse..... 10

G
Glossary..... 27
Grounding Requirements..... 14

H
High Voltage..... 3

I
Installation, Electrical..... 15
Intended Use..... 9
Introduction..... 11
ISD Servo System..... 5

M
Mounting..... 12

N
Nameplate..... 18

O
Operational Safety..... 8

Q
Qualified Personnel..... 9

S

Safety
Safety..... 7
Discharge Time..... 3
High Voltage..... 3
Instructions..... 7
Unintended Start..... 3
Warnings..... 7

Safety, Operational..... 8

Symbols..... 7

T

Trademarks..... 3

U

Unintended Start..... 3

V

Voltage Warning..... 3

W

Warning
Discharge Time..... 3
High Voltage..... 3
Unintended Start..... 3

