

GE

AF-650 GP™ & AF-600 FP™ OPCEIP EtherNet/IP

Operating Instructions



a product of
ecomagination





Contents

1 Safety	1-1
Safety Note	1-1
Safety Regulations	1-1
Warning against Unintended Start	1-2
2 Introduction	2-1
About this Manual	2-1
Technical Overview	2-1
Assumptions	2-1
Hardware	2-1
Background Knowledge	2-1
ODVA Conformance	2-2
Abbreviations	2-2
3 How to Install	3-1
Installation	3-1
The EtherNet/IP Option	3-1
How to Install Option in Adjustable Frequency Drive	3-2
LED Behavior	3-3
Topology	3-4
Network	3-5
Recommended Design Rules	3-6
EMC Precautions	3-7
4 How to Configure	4-1
IP Settings	4-1
Ethernet Link Parameters	4-2
Configuring the Scanner	4-3
IP traffic	4-5
5 How to Control	5-1
I/O Assembly Instances	5-1
EtherNet/IP Connections	5-2
Class 1 connection	5-2
Class 3 connection	5-3
Unconnected Messages, UCMM	5-3
Control Word Profile	5-3
Change of State, COS	5-4
GE Drive Control Profile	5-5
GE Drive Control Profile	5-5
Status Word according to Drive Profile (STW)	5-7



ODVA Control Profile	5-8
Control Word under Instances 20/70 and 21/71	5-8
Status Word under Instances 20/70 and 21/71	5-9
Reference Handling	5-10
Bus Speed Reference Value under Instances 100-101-103/150-151-153	5-10
Bus Speed Reference Value under Instances 20/70 and 21/71	5-10
6 Parameters	6-1
Parameter Group O-##	6-1
Parameter Group EN-##	6-5
O-## Options/Comms	6-12
EN-## EtherNet	6-13
Data Types	6-14
Data Types Supported by AF-650 GP/AF-600 FP	6-14
7 Troubleshooting	7-1
Step-by-step Troubleshooting	7-1
Alarm Word and Warning Word	7-1
8 Appendix	8-1
Supported CIP Objects	8-1



1 Safety

1

1.1.1 Copyright, Limitation of Liability and Revision Rights

This publication contains information proprietary to GE. By accepting and using this manual the user agrees that the information contained herein will be used solely for operating equipment from GE or equipment from other vendors provided that such equipment is intended for communication with GE equipment over an Ethernet serial communication link. This publication is protected under the copyright laws of Denmark and most other countries.

GE does not guarantee that a software program produced according to the guidelines provided in this manual will function properly in every physical, hardware or software environment.

Although GE has tested and reviewed the documentation within this manual, GE makes no warranty or representation, either express or implied, with respect to this documentation, including its quality, performance, or fitness for a particular purpose.

In no event shall GE be liable for direct, indirect, special, incidental, or consequential damages arising out of the use, or the inability to use information contained in this manual, even if advised of the possibility of such damages. In particular, GE is not responsible for any costs including but not limited to those incurred as a result of lost profits or revenue, loss or damage of equipment, loss of computer programs, loss of data, the costs to substitute these, or any claims by third parties.

GE reserves the right to revise this publication at any time and to make changes in its contents without prior notice or any obligation to notify previous users of such revisions or changes.

It has been assumed that all devices will be sitting behind a firewall that does packet filtering and the environment has well-implemented restrictions on the software that can run inside the firewall. All nodes are assumed to be "trusted" nodes.

1.1.2 Safety Note



The voltage of the adjustable frequency drive is dangerous whenever connected to line power. Incorrect installation of the motor, adjustable frequency drive or network may cause damage to the equipment, serious personal injury or death. Consequently, the instructions in this manual, as well as national and local rules and safety regulations, must be complied with.

1.1.3 Safety Regulations

1. The adjustable frequency drive must be disconnected from line power if repair work is to be carried out. Make sure that the line power supply has been disconnected and that the necessary time has passed before removing motor and line power plugs.
2. The [OFF] key on the Keypad of the adjustable frequency drive does not disconnect the equipment from line power and is thus not to be used as a safety switch.
3. Correct protective grounding of the equipment must be established, the user must be protected against supply voltage, and the motor must be protected against overload in accordance with applicable national and local regulations.
4. The ground leakage currents are higher than 3.5 mA.
5. Protection against motor overload is not included in the factory setting. If this function is desired, set par. to data value Electronic Thermal Overload trip or data value Electronic Thermal Overload warning.

NOTE!

The function is initialized at 1.16 x rated motor current and rated motor frequency. For the North American market, the Electronic Thermal Overload functions provide class 20 motor overload protection in accordance with NEC.

6. Do not remove the plugs for the motor and line power supply while the adjustable frequency drive is connected to line power. Make sure that the line power supply has been disconnected and that the necessary time has passed before removing motor and line power plugs.

**1**

7. Please note that the adjustable frequency drive has more voltage inputs than L1, L2 and L3 when load sharing (linking of DC intermediate circuit) and external 24 V DC have been installed. Make sure that all voltage inputs have been disconnected and that the necessary time has passed before commencing repair work.

1.1.4 Warning against Unintended Start

1. The motor can be brought to a stop by means of digital commands, bus commands, references or a local stop, while the adjustable frequency drive is connected to line power. If personal safety considerations make it necessary to ensure that no unintended start occurs, these stop functions are not sufficient.
2. While parameters are being changed, the motor may start. Consequently, the [OFF] key must always be activated.
3. A motor that has been stopped may start if faults occur in the electronics of the adjustable frequency drive, or if a temporary overload or a fault in the supply line power or the motor connection ceases.



Touching the electrical parts may be fatal - even after the equipment has been disconnected from line power.

Also make sure that other voltage inputs have been disconnected, such as external 24 V DC, load sharing (linkage of DC intermediate circuit), as well as the motor connection for kinetic backup.

Please take note of discharge times and further safety guidelines from the section "Safety and conformity" in the respective Design Guide.



2 Introduction

2.1.1 About this Manual

First time users can obtain the most essential information for quick installation and set-up in these chapters:

Introduction

How to Install

How to Configure the System

For more detailed information including the full range of set-up options and diagnosis tools, refer to the chapters:

How to Configure the System

How to Control the AF-650 GP/AF-600 FP

How to Access AF-650 GP/AF-600 FP Parameters

Parameters

Troubleshooting

Terminology:

In this manual several terms for Ethernet is used.

- **EtherNet/IP**, is the term used to describe the CIP/ODVA application protocol.
- **Ethernet**, is a common term used to describe the physical layer of the network and does not relate to the application protocol.

2.1.2 Technical Overview

EtherNet/IP™ was introduced in 2001 and today is the most developed, proven and complete industrial Ethernet network solution available for manufacturing automation. EtherNet/IP is a member of a family of networks that implements the Common Industrial Protocol (CIP™) at its upper layers. CIP encompasses a comprehensive suite of messages and services for a variety of manufacturing automation applications, including control, safety, synchronization, motion, configuration and information. As a truly media-independent protocol that is supported by hundreds of vendors from around the world, CIP provides users with unified communication architecture throughout the manufacturing enterprise.

EtherNet/IP provides users with the network tools to deploy standard Ethernet technology for manufacturing applications while enabling Internet and enterprise connectivity.

2.1.3 Assumptions

This instruction manual is under the conditions that the GE EtherNet/IP option is used in conjunction with a GE AF-650 GP or AF-600 FP adjustable frequency drive, inclusive that the installed controller supports the interfaces described in this document and that all the requirements stipulated in the controller, as well as the adjustable frequency drive, are strictly observed along with all limitations herein.

2.1.4 Hardware

This manual relates to the EtherNet/IP option OPCEIP.

2.1.5 Background Knowledge

The GE EtherNet/IP Option Card is designed to communicate with any system complying with the CIP EtherNet/IP standard. Familiarity with this technology is assumed. Issues regarding hardware or software produced by other manufacturers, including commissioning tools, are beyond the scope of this manual, and are not the responsibility of GE.

For information regarding commissioning tools, or communication to a non-GE node, please consult the appropriate manuals.



2.1.6 ODVA Conformance

The EtherNet/IP option is tested to conform to the ODVA standards, and is certified, towards conformance test level version 3.

2

2.1.7 Abbreviations

Abbreviation	Definition
API	Actual Packet Interval
CC	Control Card
CIP	Common Industrial Protocol
CTW	Control Word
DHCP	Dynamic Host Configuration Protocol
EIP	EtherNet/IP
EMC	Electromagnetic Compatibility
I/O	Input/Output
IP	Internet Protocol
LED	Light Emitting Diode
LSB	Least Significant Bit
MAR	Major Recoverable fail
MAU	Major Unrecoverable fail
MAV	Main Actual Value (actual output)
MSB	Most Significant Bit
MRV	Main Reference Value
N/A	Not applicable
ODVA	Open DeviceNet Vendor Association
PC	Personal Computer
PLC	Programmable Logic Controller
PNU	Parameter Number
REF	Reference (= MRV)
RTC	Real Time Clock
STP	Spanning tree Protocol
STW	Status Word



3 How to Install

3.1 Installation

3.1.1 The EtherNet/IP Option

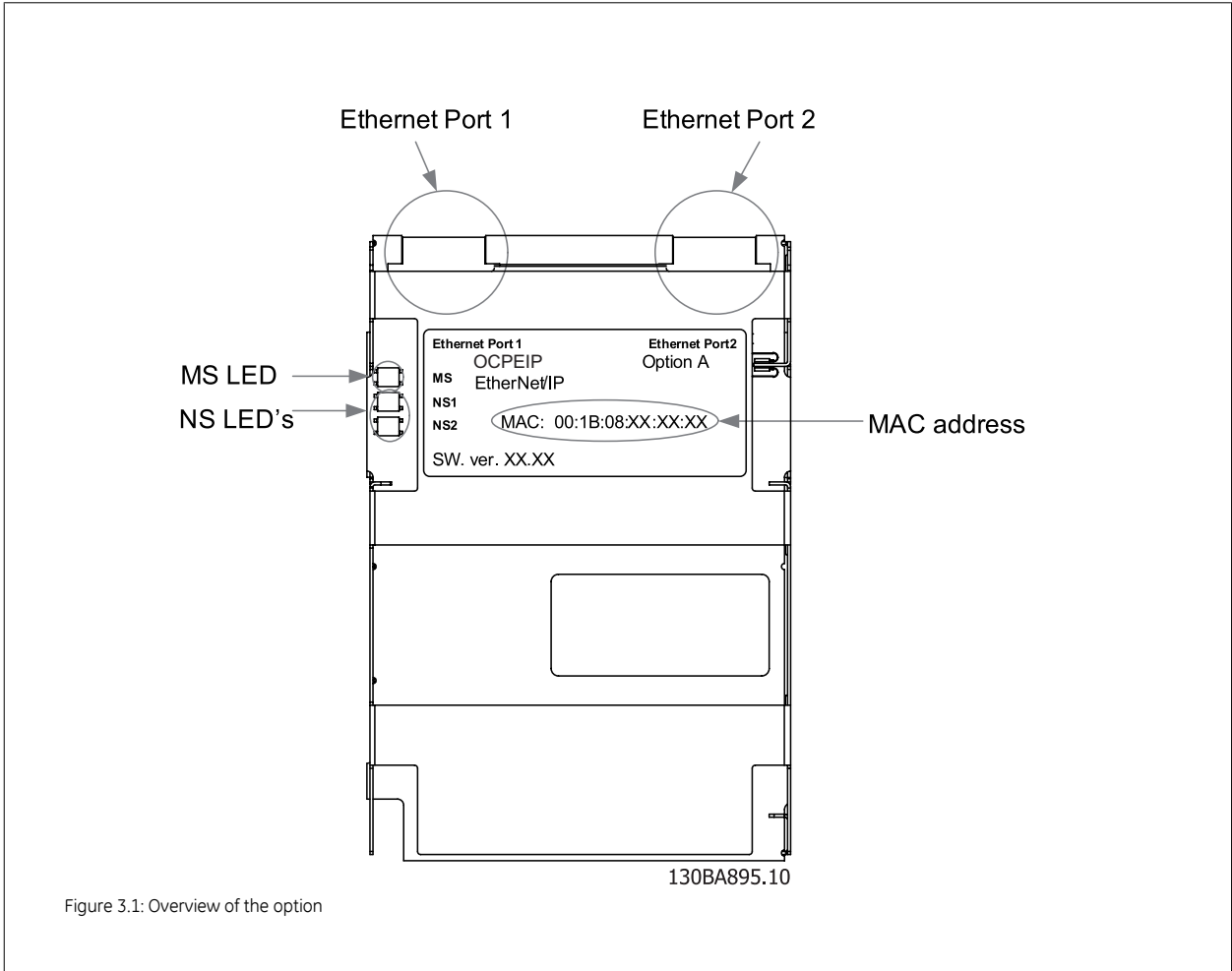


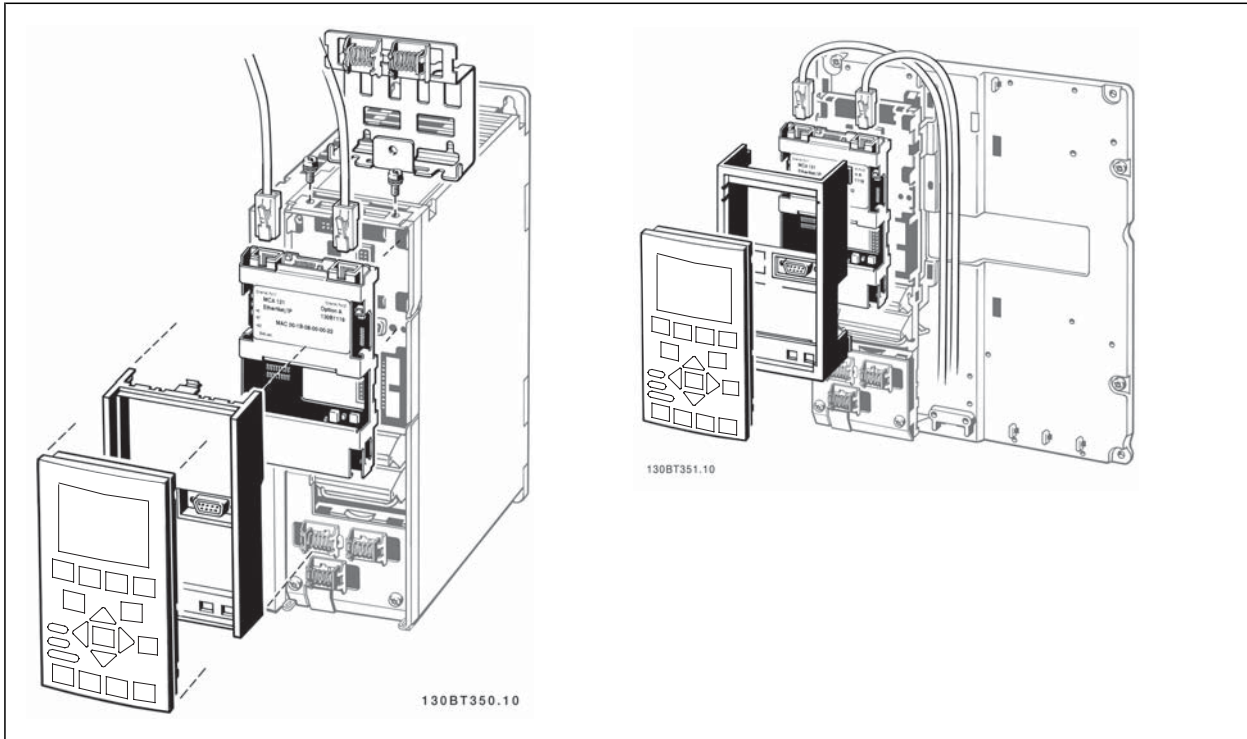
Figure 3.1: Overview of the option

3.1.2 How to Install Option in Adjustable Frequency Drive

Items required for installing a network option in the adjustable frequency drive:

- The network option
- Network option adaptor frame for the AF-650 GP/AF-600 FP. This frame is deeper than the standard frame, to allow space for the network option beneath
- Strain relief (only for unit sizes 11 and 12)

3



Instructions:

- Remove Keypad panel from the AF-650 GP/AF-600 FP.
- Remove the frame located beneath and discard it.
- Push the option into place. The Ethernet connectors must be facing upwards.
- Remove both knock-outs on the network option adaptor frame.
- Push the network option adaptor frame for the AF-650 GP/AF-600 FP into place.
- Replace the Keypad and attach cable

NOTE!

Do not strip the Ethernet cable and ground it via the strain relief-plate! The grounding of shielded Ethernet cable is done through the RJ-45 connector on the option.

NOTE!

After installing the OPCEIP option, be aware of the following parameter settings:

par. O-01 Control Site: [2] Controlword only or [0] Digital and ctrl. word

par. O-02 Control Word Source: [3] Option A



3.1.3 LED Behavior

The option has 3 bi-colored LEDs according to ODVA specifications:

LED Label	Description
MS	Module Status
NS1	Network Status Ethernet Port 1
NS2	Network Status Ethernet Port 2

The option LEDs operates according to ODVA specifications.







State	LED	Description
No power		Off The device is unpowered
Device operational	Green: 	Solid green The device is operational
Standby	Green: 	Flashing green The device needs commissioning
Minor fault	Red: 	Flashing red The device has detected a recoverable fault
Major fault	Red: 	Solid red The device has detected an unrecoverable fault
Self test	Red:  Green: 	Flashing red/green The EIP option is in self-test mode

Table 3.1: MS: Module Status







State	LED	Description
No IP address (no power)		Off The device does not have a valid IP address (or is unpowered)
No connections	Green: 	Flashing green There are no established CIP connections to the device
Connected	Green: 	Solid green There is established (at least) one CIP connection to the device
Connection timeout	Red: 	Flashing red One or more CIP connections have timed out
Duplicate IP	Red: 	Solid red The IP address assigned to the device is already in use
Self test	Red:  Green: 	Flashing red/green The EIP option is in self-test mode

Table 3.2: NS1 + NS2: Network Status (one per port)

During normal operation the MS and at least one NS LED will show a constant green light.

3.1.4 Topology

The OPCEIP features a built-in Ethernet switch and therefore has two Ethernet RJ-45 connectors. This enables the possibility for connecting several EtherNet/IP options in a line topology as an alternative to the typical star topology.

The two ports are equal, in the sense that they are transparent for the option. If only one connector is used, either port can be used.

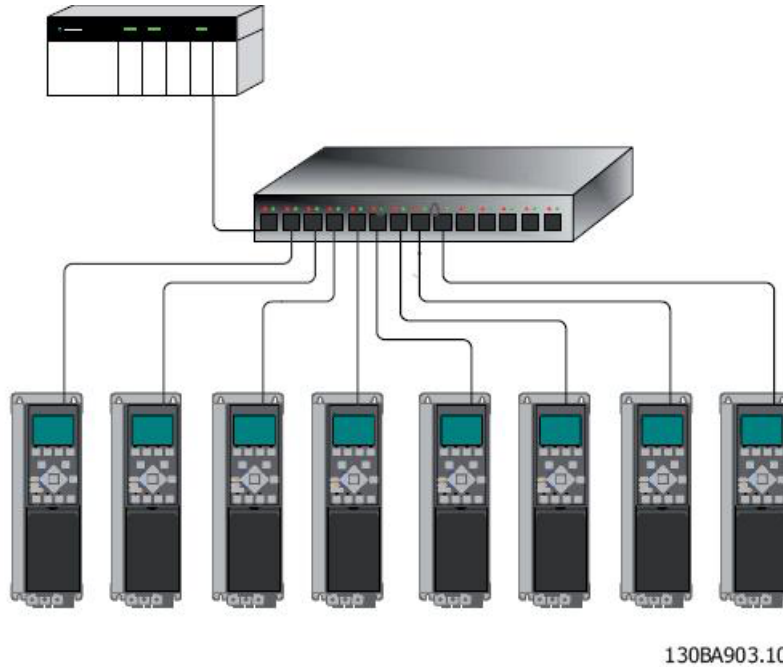
3

Figure 3.2: Star topology

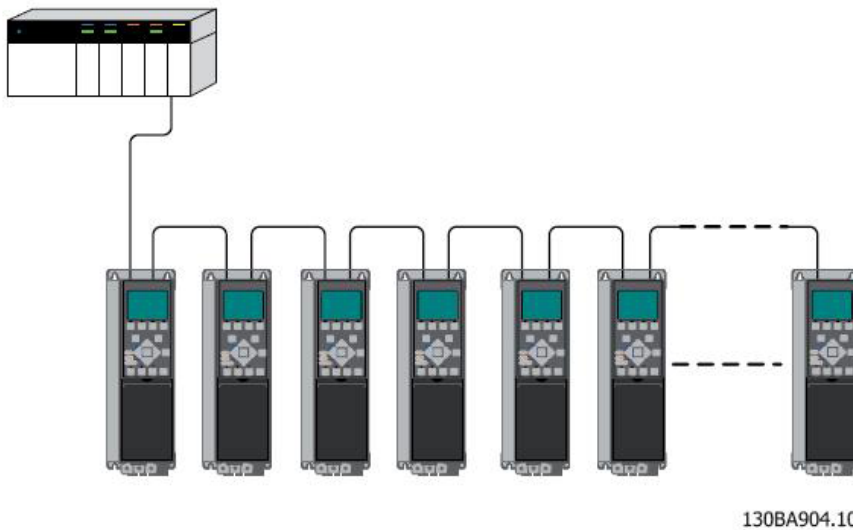


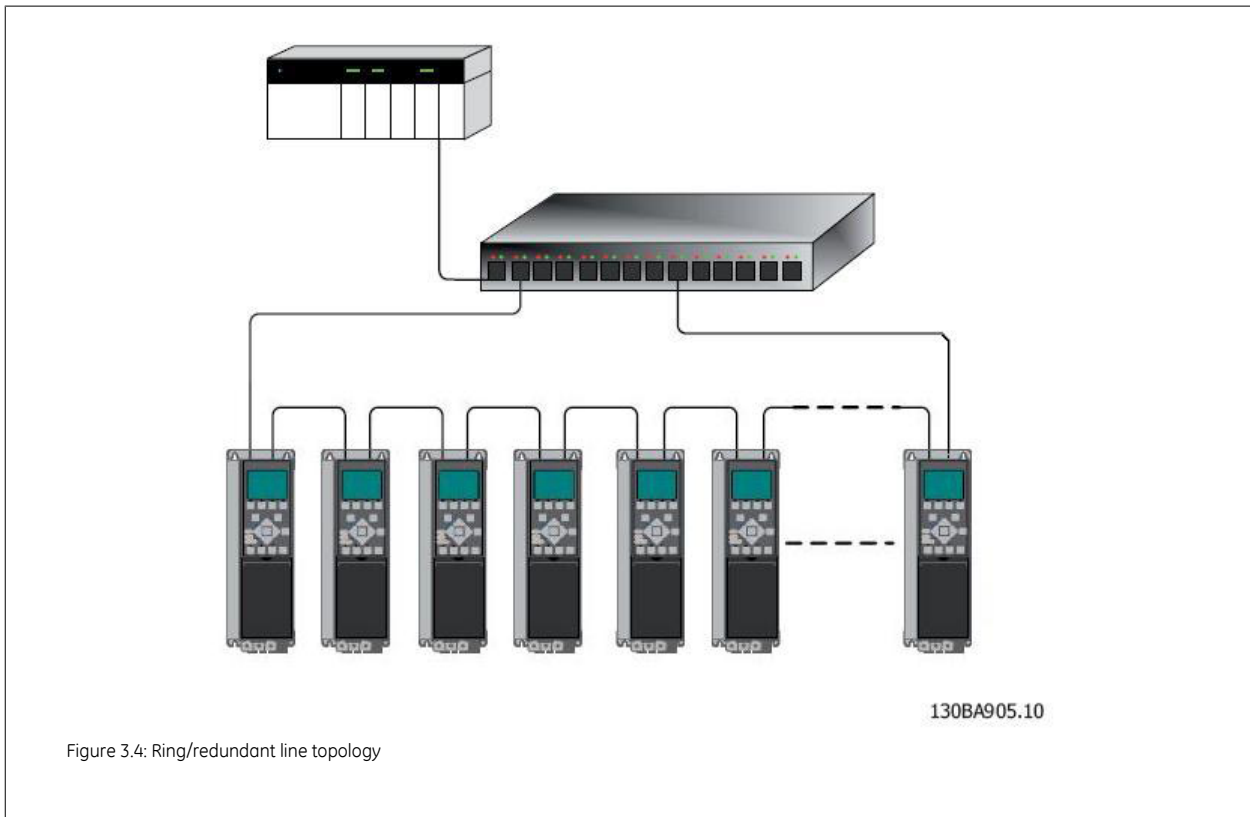
Figure 3.3: Line topology

NOTE!

For line topology, please refer to section "Recommended design rules". In a line topology, all drives must be powered, either by line power or by their 24 V DC option cards, for the built-in switch to work.

**NOTE!**

Please observe that mounting drives of different power sizes in a line topology may result in unwanted power-off behavior. Smaller drives discharge faster than bigger drives. This can result in loss of link in the line topology, which may lead to control word timeout. To avoid this, mount the drives with the longest discharge time first in the line topology.

**NOTE!**

For this type of topology, it is crucial that the network switch supports Spanning Tree Protocol (STP) or Rapid Spanning Tree (RSTP), and that STP is enabled. For more information on Spanning Tree please refer to section *IP traffic*.

3.1.5 Network

It is of high importance that the media chosen for Ethernet data transmission are suitable. Usually CAT 5e and 6 cables are recommended for industrial applications. Both types of cable are available as unshielded twisted pair and shielded twisted pair. Generally shielded cables are recommended for use in industrial environments and with adjustable frequency drives.

A maximum cable length of 328 ft [100 m] is allowed between switches.

Optical fibers can be used for gapping longer distances and providing galvanic isolation.

For connecting EtherNet/IP devices, both hubs and switches can be used. It is, however, recommended to always use suitable industrial-grade Ethernet switches. For more information regarding IP switching, please refer to the section *IP Traffic* in this manual.



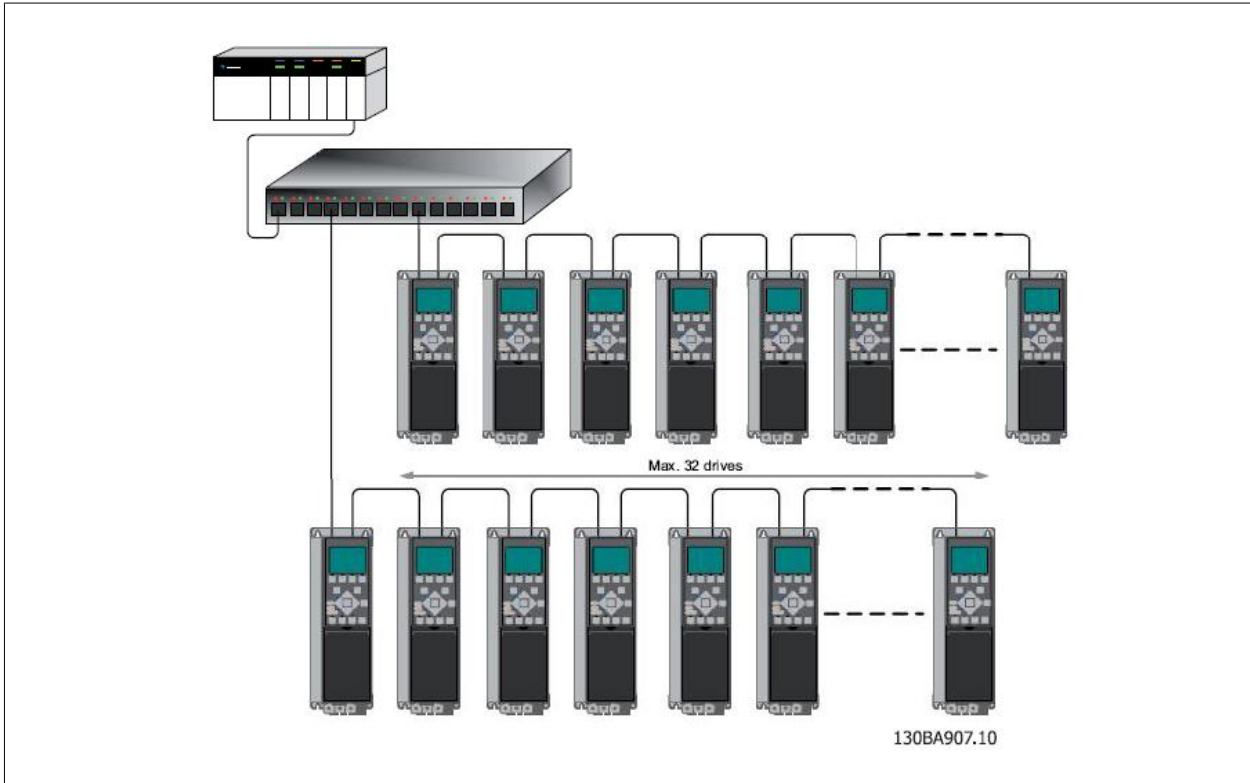
3.1.6 Recommended Design Rules

While designing Ethernet networks, special attention and caution must be taken regarding active network components.

While designing a network for line topology, it is important to notice that a small delay is added with each every switch in the line.

It is not recommended to connect more than 32 drives in a line at any API. Exceeding the recommended design rules, may result in failing communication.

3





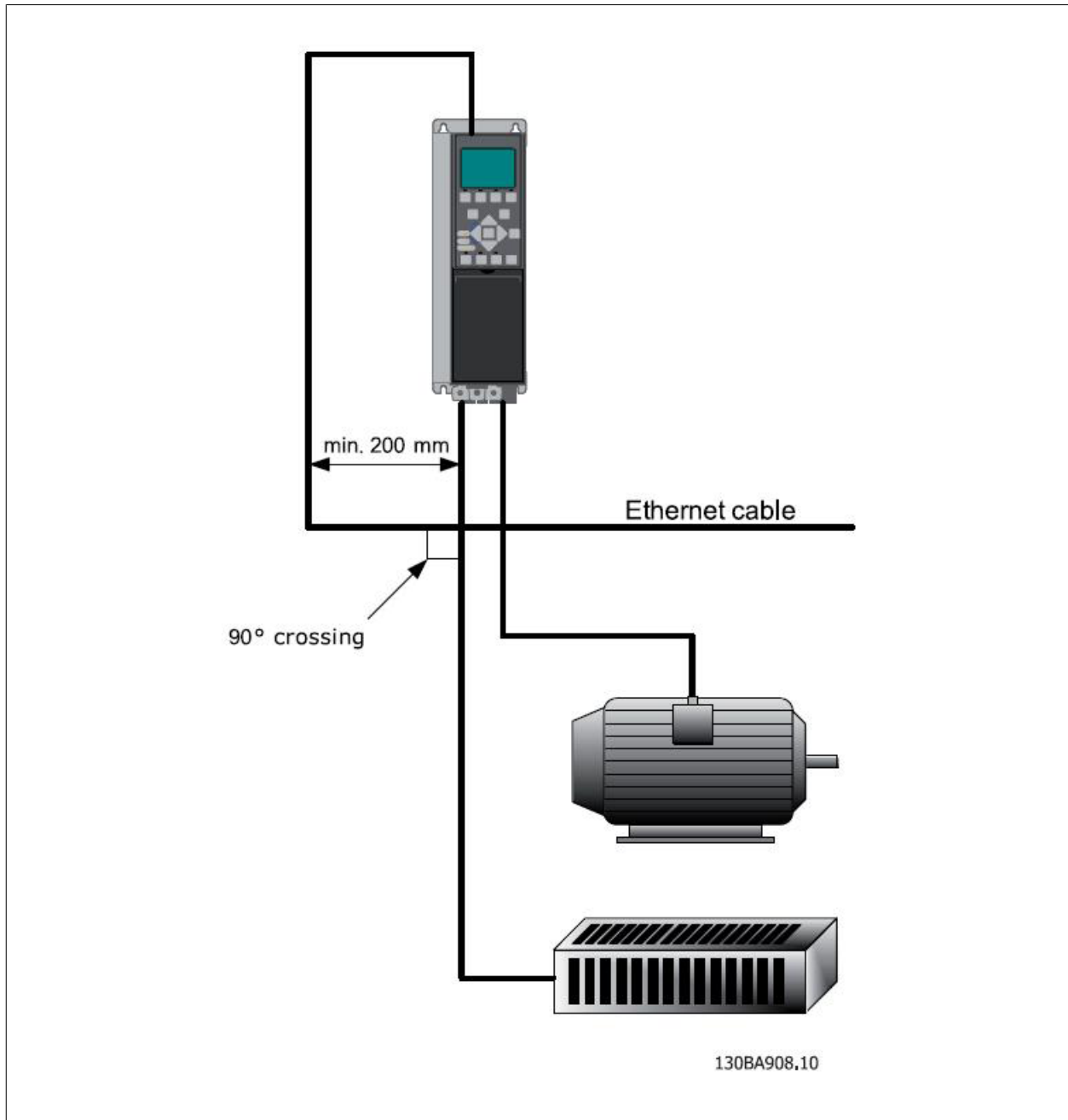
3.1.7 EMC Precautions

The following EMC precautions are recommended in order to achieve interference-free operation of the Ethernet network. Additional EMC information is available in the AF-650 GP/AF-600 FP series Design Guide.

NOTE!

Relevant national and local regulations, for example, regarding protective ground connection, must be observed.

The Ethernet communication cable must be kept away from motor and brake resistor cables to avoid coupling of high frequency noise from one cable to the other. Normally a distance of 8 in (200 mm) is sufficient, but maintaining the greatest possible distance between the cables is recommended, especially where cables run in parallel over long distances. When crossing is unavoidable, the Ethernet cable must cross motor and brake resistor cables at an angle of 90 degrees.

3





4 How to Configure

4.1.1 IP Settings

All IP-related parameters are located in parameter group EN-##:

EN-00	IP Address Assignment
EN-01	IP Address
EN-02	Subnet Mask
EN-03	Default Gateway
EN-04	DHCP Server
EN-05	Lease Expires
EN-06	Name Servers
EN-07	Domain Name
EN-08	Host Name
EN-09	Physical Address

The OPCEIP option offers several ways of IP address assignment.

Setting up drive with manual assigned IP address:

Par.	Name	Value
EN-00	<i>IP Address Assignment</i>	[0] MANUAL
EN-01	<i>IP Address</i>	192.168.0.xxx*
EN-02	<i>Subnet Mask</i>	255.255.255.0*
EN-03	<i>Default Gateway</i>	optional

*= Class C IP address example. Any valid IP address can be entered.

NOTE!

A power cycle is necessary after setting the IP parameters manually.

Setting up drive with automatic (BOOTP/DHCP) assigned IP address:

Par.	Name	Value
EN-00	<i>IP Address Assignment</i>	[1] DHCP/[2] BOOTP
EN-01	<i>IP Address</i>	Read only
EN-02	<i>Subnet Mask</i>	Read only
EN-03	<i>Default Gateway</i>	Read only

Using the IP address assigned by the DHCP/BOOTP server, the assigned *IP Address* and *Subnet Mask* can be read out in par. EN-01 and EN-02. In par. EN-04 *DHCP Server*, the IP address of the found DHCP or BOOTP server is displayed. For DHCP only: The remaining lease time can be readout in par. EN-05 *Lease Expires*.

Par. EN-09, *Physical Address* reads out the MAC address of option, which is also printed on the label of the option. If using fixed leases together with DHCP or BOOTP, the physical MAC address is linked with a fixed IP address.

NOTE!

If no DHCP or BOOTP reply has been received after 4 attempts (e.g., if the DHCP/BOOTP server has been powered off), the option will fall back to the last known good IP address.



Par. EN-03, *Default Gateway* is optional and only used in routed networks.

Par. EN-06, *Name Servers*

Par. EN-07, *Domain Name*

Par. EN-08, *Host Name*

Are used with Domain Name Server systems and are all optional. If either DHCP or BOOTP is selected as the IP address assignment, these parameters are read only.

NOTE!

It is only possible to assign valid class A, B and C IP addresses to the option. The valid ranges are shown in the table below:

Class A	1.0.0.1 - 126.255.255.254
Class B	128.1.0.1 - 191.255.255.254
Class C	192.0.1.1 - 223.255.254.254

4

4.1.2 Ethernet Link Parameters

Parameter group EN-1# holds Ethernet link information:

EN-10	Link Status
EN-11	Link Duration
EN-12	Auto Negotiation
EN-13	Link Speed
EN-14	Link Duplex

Please note the Ethernet Link Parameters are unique per port.

Par. EN-10, *Link Status* and par. EN-11, *Link Duration* displays information on the link status, per port.

Par. EN-10, *Link Status* will display Link or No Link according to the status of the present port.

Par. EN-11, *Link Duration* will display the duration of the link on the present port. If the link is broken, the counter will be reset.

Par. EN-12, *Auto Negotiation* – is a feature that enables two connected Ethernet devices to choose common transmission parameters, such as speed and duplex mode. In this process, the connected devices first share their capabilities as for these parameters and then choose the fastest transmission mode they both support.

By default, this function is enabled.

Incapability between the connected devices may lead to decreased communication performance.

To prevent this, auto negotiation can be disabled.

If par. EN-12 is set to OFF, link speed and duplex mode can be configured manually in par. EN-13 and EN-14.

Par. EN-12, *Link Speed* – displays/sets the link speed per port. "None" is displayed if no link is present.

Par. EN-14, *Link Duplex* – displays/sets the duplex mode per port.

Half-duplex provides communication in both directions but only in one direction at a time (not simultaneously).

Full-duplex allows communication in both directions, and unlike half-duplex, allows for this to happen simultaneously.



4.1.3 Configuring the Scanner

EDS file

GE provides a generic English EDS (Electronic Data Sheet) file covering all voltage and power sizes, for off-line configuration.

The EDS file can be downloaded from:

www.geelectrical.com/drives

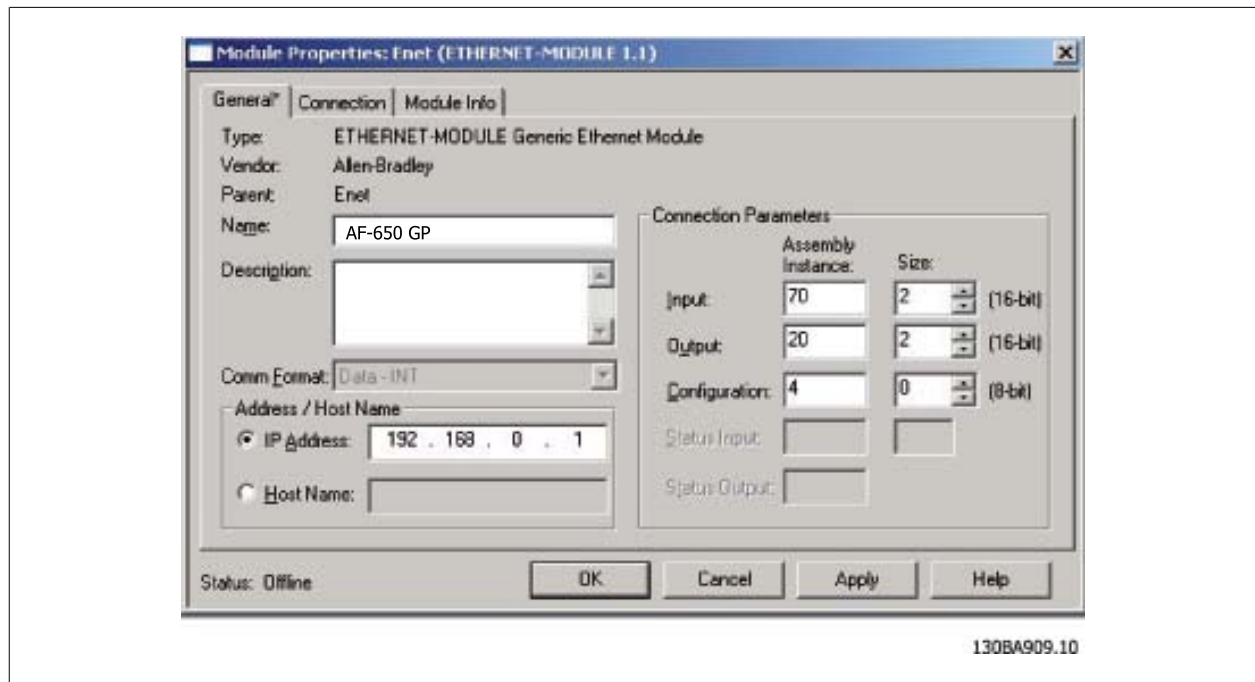
NOTE!
The current version of the major EtherNet/IP configuration tools does not support EDS files for EtherNet/IP devices.

Configuring a Rockwell Master

For configuring a AF-650 GP/AF-600 FP with OCPEIP for operation with a Rockwell (Allen-Bradley) Scanner via EtherNet/IP, the AF-650 GP must be added as a *Generic Ethernet Module*.



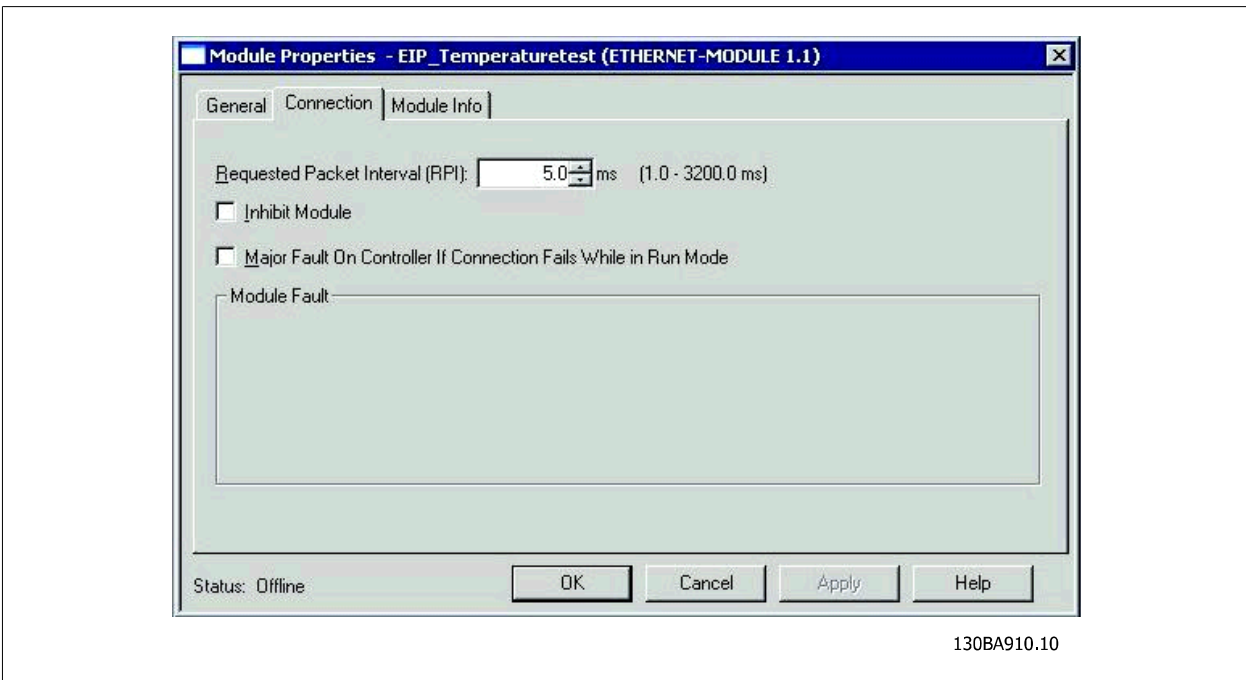
Under the *General* tab, enter information about name of device, IP address, assembly instance and data size.



NOTE!
Under *Configuration* in the Connection Parameters a "4" must be entered as the Assembly Instance.

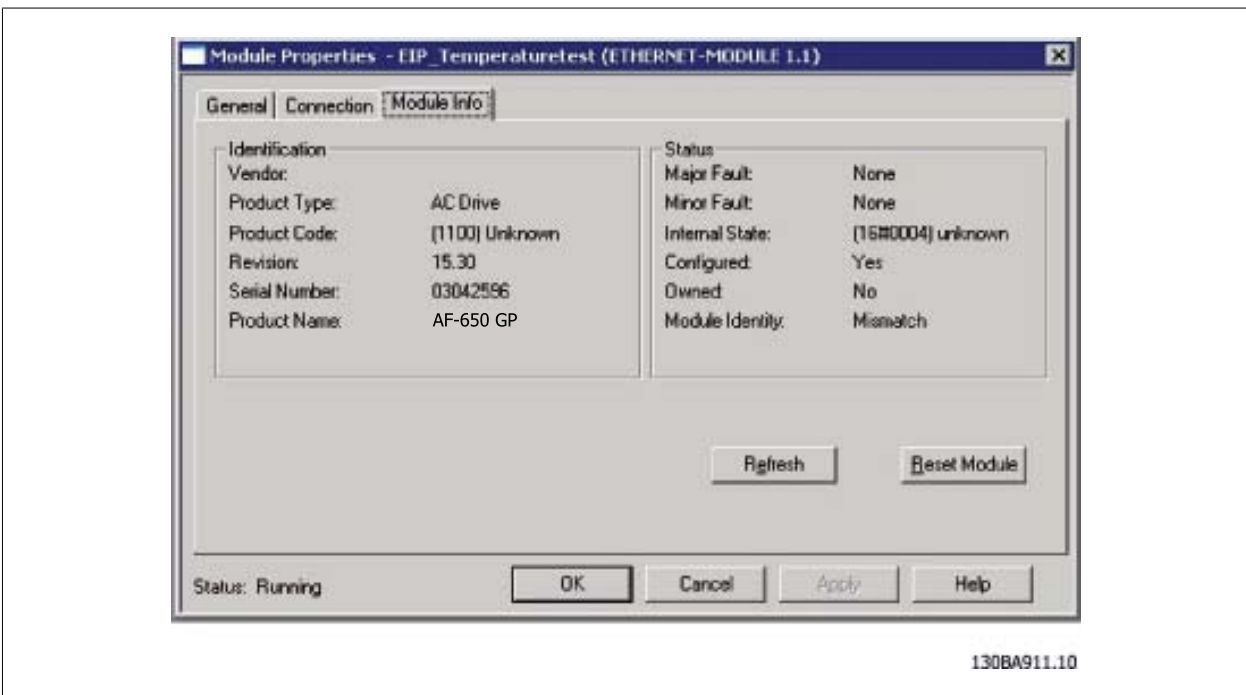
NOTE!
Please note that the example shows a 20/70 assembly instance connection. This requires to be set to ODVA. Other supported connections are shown in section *I/O Assembly Instanced*.

Under the *Connection* tab, enter information about RII and fault conditions.



The *Module Info* – This tab holds generic information.

The *Reset Module* – This button will make a simulated power cycle of the drive.



NOTE!

For more information on the CIP class 1 Forward Open command, please refer to section *EtherNet/IP Connections* in the chapter *How to Control*.



4.1.4 IP traffic

The use of Ethernet-based network for industrial automation purposes calls for careful and thorough network design. Especially the use of active network components like switches and routers requires detailed know-how about the behavior of IP traffic.

Some important issues:

Multicast

Multicast traffic is traffic that is addressed to a number of recipients. Each host processes the received multicast packet to determine if it is the target for the packet. If not, the IP package is discarded. This causes an excessive network load on each node in the network since they are flooded with multicast packages. The nature of EtherNet/IP traffic is that all originator-to-target traffic is unicast (point-to-point) but target-to-originator traffic is optional multicast. This enables several listen-only connections to be made to a single host.

In switched networks, hosts also have the risk of becoming flooded with multicast traffic. A switch usually forwards traffic by MAC address tables built by looking into the source address field of all the frames it receives.

A multicast MAC address is never used as a source address for a packet. Such addresses do not appear in the MAC address table, and the switch has no method for learning them so it simply forwards all multicast traffic to all connected hosts.

IGMP

IGMP (Internet Group Management Protocol) is an integrated part of IP. It allows hosts to join or leave a multicast host group. Group membership information is exchanged between a specific host and the nearest multicast router.

For EtherNet/IP networks, it is essential that the switches used support **IGMP snooping**. IGMP snooping enables the switch to "listen in" on the IGMP conversation between hosts and routers. By doing this, the switch will recognize which hosts are members of which groups, thus being able to forward multicast traffic only to the appropriate hosts.

Spanning Tree Protocol (STP)

For an Ethernet network to function properly, only one active path can exist between two nodes. The Spanning Tree Protocol is a link management protocol that provides path redundancy while preventing undesirable loops in the network.

When loops occur, some switches see stations appear on both sides of themselves. This condition confuses the forwarding algorithm and allows for duplicate frames to be forwarded.

To provide path redundancy, the Spanning Tree Protocol defines a tree that spans all switches in an extended network. The Spanning Tree Protocol forces certain redundant data paths into a standby (blocked) state. If one network segment in the Spanning Tree Protocol becomes unreachable, or if the Spanning Tree Protocol costs change, the spanning tree algorithm reconfigures the spanning tree topology and re-establishes the link by activating the standby path.

Spanning Tree Protocol operation is necessary if the AF-650 GPor AF-600 FP is running in a ring/redundant line topology.





5 How to Control

5.1 How to Control

5.1.1 I/O Assembly Instances

I/O assembly instances are a number of defined process control objects with defined content comprising control and status information. Unlike DeviceNet, it is possible to run with asymmetrical instances, e.g., 101/153 = 8 bytes/20 bytes.

It is not possible to mix instances across profiles, e.g., 20/100. Assembly instances must be consistent to the ODVA or Drive profile.

The controlling instance can be read in par. EN-20, *Control Instance*.

The figure below shows the I/O Assembly Instance options for controlling and monitoring the AF-650 GP/AF-600 FP drive.

Profile (par. O-10 Control Word Profile)	Direction	Instances (decimal)	Size (bytes)	Data
ODVA	Originator →Target	20	4	CTW (20) REF
		21	4	CTW (21) REF
	Target →Originator	70	4	STW (70) MAV
		71	4	STW (71) MAV
Drive	Originator →Target	100	4	CTW (Drive) REF 130BA916.10
		101	8	CTW (Drive) REF PCD [2] PCD [3] 130BA917.10
		103	20	CTW (Drive) REF PCD [2] PCD [9] 130BA918.10
	Target →Originator	150	4	STW (Drive) MAV 130BA919.10
		151	8	STW (Drive) MAV PCD [2] PCD [9] 130BA920.10
		153	20	STW (Drive) MAV PCD [2] PCD [9] 130BA921.10

**NOTE!****Use of 32-bit process data.**

For configuration of a 2-word (32-bit) parameter read/write, use 2 consecutive arrays in par. EN-21 and EN-22 such as [2]+[3], [4]+[5], [6]+[7] etc. Read/write of 2-word values in arrays such as [3]+[4], [5]+[6], [7]+[8] are not possible.

5.1.2 EtherNet/IP Connections

The OPCEIP option supports the CIP connections described in the following sections:

5.1.3 Class 1 connection

I/O connection using TCP transport. The maximum Class 1 connection is supported by the EtherNet/IP option, but several listen-only connections can be established if multicast is selected as the transport type. This type of connection is used for cyclic I/O and change-of-state connections. The connection is established with a

Forward Open command containing the following information:

Transport Type:

Specified for both directions:

- Originator-to-Target / Target-to-Originator.
- Point to Point
- Multicast (target-to-originator only)

Data Size:

Specified (in bytes) for both directions: originator -> target / target -> originator.

The data size depends on the assembly instance chosen in *Destination*.

Instances (decimal)		Data Size
Originator →Target	Target →Originator	
20, 21, 100	70, 71, 150	4 bytes
101	151	8 bytes
103	153	20 bytes

Packet Rate:

Specified (in milliseconds) for both directions: Originator -> target / target -> originator.

Minimum packet rate supported: **1 ms**

Production Inhibit Timeout:

Specifies (in milliseconds) the timeout time for both directions.

Trigger:

Selects the transport trigger type:

- Cyclic (data is transmitted cyclically as polled I/O)
- Change Of State (data is transmitted on change of state only. COS filters are set up in par. EN-38 COS filters)

Connection Points

Specified for both directions: originator -> target / target -> originator.

Profile (par. O-10 Control Word Profile)	Direction	Connection Points (decimal)
ODVA	Originator →Target	20, 21
	Target →Originator	70, 71
Drive	Originator →Target	100, 101, 103
	Target →Originator	150, 151, 153



5.1.4 Class 3 connection

Cyclic connection using UDP transport.

Maximum 6 Class 3 connections are supported.

This type of connection is used for explicit messaging. The connection is established with a Forward Open command containing the following information:

Connection Name:

Given name for the connection

Message Parameters

- Service Code
- Class
- Instance
- Attribute
- Member
- Request Data

5.1.5 Unconnected Messages, UCMM

Non-cyclic (single) connection using TCP transport.

This type of connection is used for explicit messaging. The connection is established on-the-fly and does not require any Forward Open command.

Message Parameters

- Service Code
- Class
- Instance
- Attribute
- Member
- Request Data

Please refer to section Appendix for information on accessing CIP objects explicitly.

5.1.6 Control Word Profile

The control profile is selected in par. O-10 *Control Word Profile*

- ODVA gives access to the ODVA specific profiles and assembly instances: 20, 21, 70 and 71.
- The drive enables the GE profile and assembly instances: 100, 101, 103, 150, 151 and 153.

For more information on the different profiles, please refer to the subsequent sections.

NOTE!

Change of control profile

It is only possible to change the control profile while the drive is stopped. The control word and reference will not be recalculated to match the selected profile, but are kept at the last good known value.



5.1.7 Change of State, COS

The event controlled operation mode is used to minimize network traffic. Messages are transmitted only if a defined state or value has changed. The condition for triggering a COS message is determined by the insertion of COS filters (par. EN-38) for each bit in the different PCD words.

The filter acts like a logical AND function. If a bit in the filter is set to "1", the COS function triggers when there is a change to the corresponding bit for the PCD word.

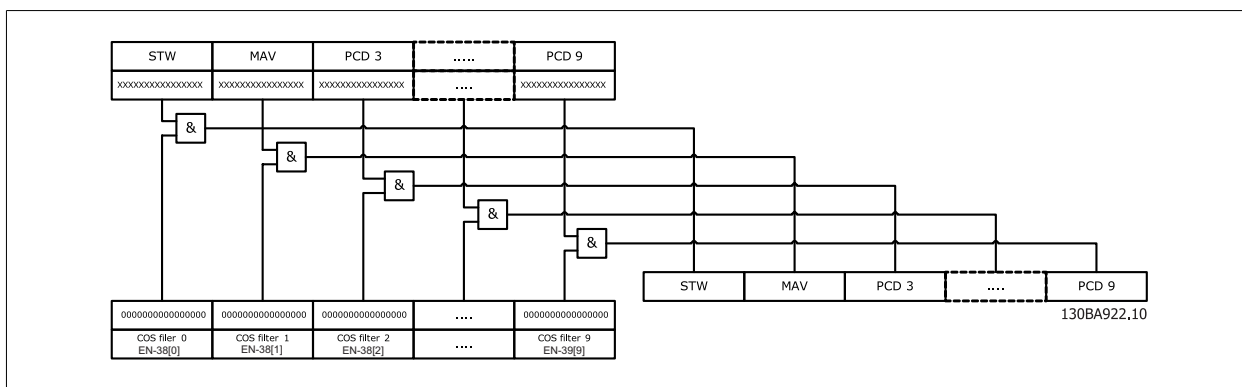
Parameter EN-38 can be used to filter out undesired events for COS. If a filter bit is set to 0, the corresponding I/O Instance bit will be unable to produce a COS message. By default, all bits in the COS filters are set to 0.

In order to signal that the connection has not been interrupted, or the device is not powered off, a heartbeat message is transmitted within a specified time interval (heartbeat interval). This interval is defined in the attribute heartbeat time of the connection object, Class 0x01.

5

To prevent the device from producing heavy network traffic when a value changes frequently, a production inhibit time is defined in par. EN-37. This parameter defines the minimum time between two COS messages. If par. EN-37 is set to 0, the production inhibit timer is disabled.

The figure below shows the different PCDs and their corresponding filter parameters.





5.2 GE Drive Control Profile

5.2.1 GE Drive Control Profile

Control Word according to the Drive Profile. Instances 100, 101, 103/150, 151, 153

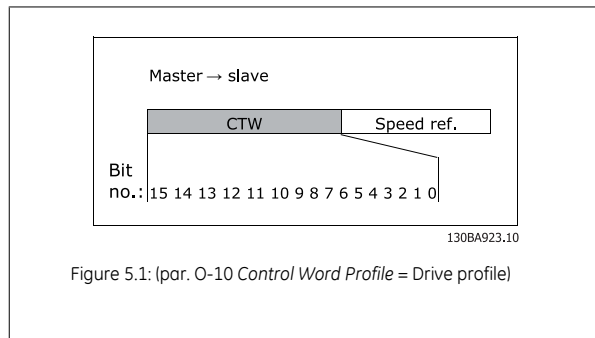


Figure 5.1: (par. 0-10 Control Word Profile = Drive profile)

Bit	Bit value = 0	Bit value = 1
00	Reference value	External selection LSB
01	Reference value	External selection MSB
02	DC brake	Ramp
03	Coasting	No coasting
04	Quick stop	Ramp
05	Hold output frequency	Use ramp
06	Ramp stop	Start
07	No function	Reset
08	No function	Jog
09	Ramp 1	Ramp 2
10	Data invalid	Data valid
11	No function	Relay 01 active
12	No function	Relay 04 active
13	Parameter set-up	Selection LSB
14	Parameter set-up	Selection MSB
15	No function	Reverse

Explanation of Control Bits

Bits 00/01

Bits 00 and 01 are used to choose between the four reference values, which are pre-programmed in par. C-05 *Multi-step Frequency 1 - 8* according to the following table:

Programmed ref. value	Parameter	Bit 01	Bit 00
1	C-05 [0]	0	0
2	C-05 [1]	0	1
3	C-05 [2]	1	0
4	C-05 [3]	1	1

NOTE!

In par. 0-56 *Preset Reference Select*, select a selection is made to define how Bit 00/01 gates with the corresponding function on the digital inputs.

Bit 02, DC brake:

Bit 02 = '0' leads to DC braking and stop. Braking current and duration are set in par. B-01 *DC Brake Current* and par. B-02 *DC Braking Time*. Bit 02 = '1' leads to ramping, par. F-07 *Accl Time 1*

Bit 03, Coasting:

Bit 03 = '0' causes the adjustable frequency drive to immediately "let go" of the motor (the output transistors are "shut off"), so that it coasts to a standstill. Bit 03 = '1' enables the adjustable frequency drive to start the motor if the other starting conditions have been fulfilled.

NOTE!

In par. 0-50 *Coasting Select* a selection is made to define how Bit 03 gates with the corresponding function on a digital input.

Bit 04, Quick stop:

Bit 04 = '0' causes a stop, in which the motor speed is decelerated to stop via par. C-23 *Quick Stop Decel Time*.

Bit 05, Hold output frequency:

Bit 05 = '0' causes the present output frequency (in Hz) to freeze. The frozen output frequency can then be changed only by means of the digital inputs (par. E-01 *Terminal 18 Digital Input* to par. E-06 *Terminal 33 Digital Input*) programmed to Speed up and Slow.

NOTE!

If freeze output is active, the adjustable frequency drive can only be stopped by the following:

- Bit 03 Coasting stop
- Bit 02 DC braking
- Digital input (par. E-01 *Terminal 18 Digital Input* to par. E-06 *Terminal 33 Digital Input*) programmed to DC braking, Coasting stop or Reset and coasting stop

**Bit 06, Ramp stop/start:**

Bit 06 = '0' causes a stop in which the motor speed is decelerated to stop via the selected *decel* parameter. Bit 06 = '1' permits the adjustable frequency drive to start the motor if the other starting conditions have been fulfilled.

NOTE!

In par. O-53 *Start Select* Start select, a selection is made to define how Bit 06 Ramp stop/start gates with the corresponding function on a digital input.

Bit 07, Reset:

Bit 07 = '0' no reset. Bit 07 = '1' resets a trip. Reset is activated on the leading edge of the signal, i.e., when changing from logic '0' to logic '1'.

Bit 08, Jog:

Bit 08 = '1' causes the output frequency to be determined by par. C-21 *Jog Speed (RPM)*.

Bit 09, Selection of ramp 1/2:

Bit 09 = '0' means that ramp 1 is active (par. H-07 *Accel/Decel Time 1 Type* to par. SP-73 *Decl Time 1 S-ramp Rat at Decl Start*). Bit 09 = '1' means that ramp 2 (par. SP-76 *Accel/Decel Time 2 Type* to par. SP-81 *Decl Time 2 S-ramp Rat at Decl Start*) is active.

Bit 10, Data not valid/Data valid:

This bit tells the adjustable frequency drive whether the control word is to be used or ignored. Bit 10 = '0' causes the control word to be ignored, Bit 10 = '1' causes the control word to be used. The control word is always contained in the message regardless of which type of message is used, so this function is useful for 'turning off' the control word when not required for updating or reading parameters.

Bit 11, Relay 01:

Bit 11 = '0' Relay not activated. Bit 11 = '1' Relay 01 activated, provided *Control word bit 11* has been chosen in par. E-24 *Function Relay*.

Bit 12, Relay 02:

Bit 12 = '0' Relay 02 has not been activated. Bit 12 = '1' Relay 02 has been activated, provided *Control word bit 12* has been chosen in par. E-24 *Function Relay*.

Bit 13/14, Selection of set-up:

Bits 13 and 14 are used to select one of four menu set-ups according to the following table:

Set-up	Bit 14	Bit 13
1	0	0
2	0	1
3	1	0
4	1	1

The function is only possible when *Multi Set-ups* is selected in par. K-10 *Active Set-up*.

NOTE!

In par. O-55 *Set-up Select*, a selection is made to define how Bit 13/14 gates with the corresponding function on the digital inputs.

Bit 15 Reverse:

Bit 15 = '0' causes no reversing. Bit 15 = '1' causes reversing. Note: In the factory setting reversing is set to *digital* in par. O-54 *Reversing Select*. Bit 15 causes reversing only when *Ser. communication*, *Logic AND* or *Logic OR* is selected.



5.2.2 Status Word according to Drive Profile (STW)

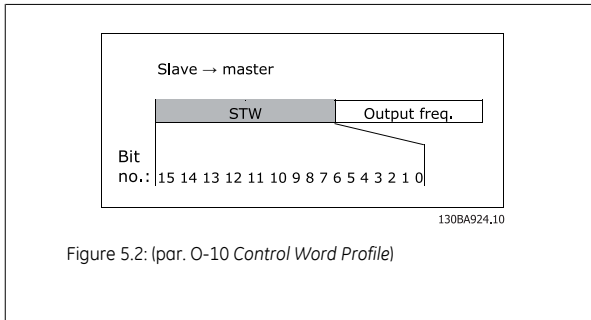


Figure 5.2: (par. 0-10 Control Word Profile)

Bit	Bit value = 0	Bit value = 1
00	Control not ready	Control ready
01	Drive not ready	Drive ready
02	Coasting	Enable
03	No error	Trip
04	No error	Error (no trip)
05	Reserved	-
06	No error	Trip lock
07	No warning	Warning
08	Speed ≠ reference	Speed = reference
09	Local operation	Bus control
10	Out of frequency limit	Frequency limit ok
11	No operation	In operation
12	Drive ok	Stopped, auto start
13	Voltage ok	Voltage exceeded
14	Torque ok	Torque exceeded
15	Thermal ok	Thermal exceeded

Explanation of the Status Bits

Bit 00, Control ready:

Bit 00 = '0' means that the adjustable frequency drive has tripped. Bit 00 = '1' means that the adjustable frequency drive controls are ready, but that the power component is not necessarily receiving any power supply (in the event of external 24 V supply to controls).

Bit 01, Drive ready:

Bit 01 = '1'. The adjustable frequency drive is ready for operation.

Bit 02, Coasting stop:

Bit 02 = '0'. The adjustable frequency drive has released the motor. Bit 02 = '1'. The adjustable frequency drive can start the motor when a start command is given.

Bit 03, No error/Trip:

Bit 03 = '0' means that the adjustable frequency drive is not in fault mode. Bit 03 = '1' means that the adjustable frequency drive is tripped, and that a reset signal is required to reestablish operation.

Bit 04, No error/Error (no trip):

Bit 04 = '0' means that the adjustable frequency drive is not in fault mode. Bit 04 = '1' means that there is an adjustable frequency drive error but no trip.

Bit 05, Reserved:

Bit 05 is not used in the status word.

Bit 06, No error / Trip lock:

Bit 06 = '0' means that the adjustable frequency drive is not in fault mode. Bit 06 = '1' means that the adjustable frequency drive is tripped, and locked.

Bit 07, No warning/Warning:

Bit 07 = '0' means that there are no warnings. Bit 07 = '1' means that a warning has occurred.

Bit 08, Speed ≠ reference/Speed = reference:

Bit 08 = '0' means that the motor is running, but that the present speed is different from the preset speed reference. For example, this might occur while the speed is being accelerated/decelerated during start/stop. Bit 08 = '1' means that the present motor speed matches the preset speed reference.

Bit 09, Local operation/Bus control:

Bit 09 = '0' means that [STOP/RESET] is activated on the control unit, or that Local control in par. F-02 Operation Method is selected. It is not possible to control the adjustable frequency drive via serial communication. Bit 09 = '1' means that it is possible to control the adjustable frequency drive via the network/ serial communication.

Bit 10, Out of frequency limit:

Bit 10 = '0', if the output frequency has reached the value in par. F-18 Motor Speed Low Limit [RPM] or par. F-17 Motor Speed High Limit [RPM]. Bit 10 = '1' means that the output frequency is within the defined limits.

Bit 11, No operation/In operation:

Bit 11 = '0' means that the motor is not running. Bit 11 = '1' means that the adjustable frequency drive has a start signal or that the output frequency is greater than 0 Hz.

Bit 12, Drive OK/Stopped, auto-start:

Bit 12 = '0' means that there is no temporary overtemperature on the inverter. Bit 12 = '1' means that the inverter has stopped because of overtemperature, but that the unit has not tripped and will resume operation once the over-temperature stops.

Bit 13, Voltage OK/Voltage exceeded:

Bit 13 = '0' means that there are no voltage warnings. Bit 13 = '1' means that the DC voltage in the adjustable frequency drive's intermediate circuit is too low or too high.

Bit 14, Torque OK/Torque limit exceeded:

Bit 14 = '0' means that the motor current is lower than the torque limit selected in par. F-40 and F-41 Torque limit. Bit 14 = '1' means that the torque limit in par. F-40 and F-41 Torque limit has been exceeded. The nominal torque can be read in par. DR-16 Torque [Nm].

Bit 15, Thermal OK/limit exceeded:

Bit 15 = '0' means that the timers for both motor thermal protection and drive thermal protection have not exceeded 100%. Bit 15 = '1' means that one of the limits has exceeded 100%.

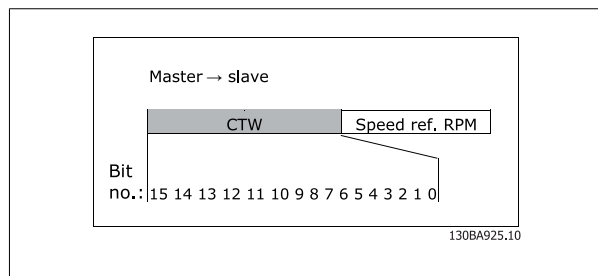


5.3 ODVA Control Profile

5.3.1 Control Word under Instances 20/70 and 21/71

Set par. O-10 *Control Word Profile* to ODVA.

The control word in Instances 20 and 21 is defined as follows:



NOTE!
Bits 00 and 02 in Instance 20 are identical with bits 00 and 02 in the more extensive Instance 21.

Bit	Instance 20		Instance 21	
	Bit = 0	Bit = 1	Bit = 0	Bit = 1
00	Stop	Run	Fwd Stop	Run Fwd
01	-	-	Stop	Run Rev
02	No function	Fault reset	No function	Fault reset
03	-	-	-	-
04	-	-	-	-
05	-	-	-	Net Ctrl
06	-	-	-	Net Ref
07-15	-	-	-	-

Explanation of the Bits:

Bit 0, Run Fwd:

Bit 0 = "0" means that the drive has a stop command. Bit 0 = "1" leads to a start command and the drive will start to run the motor clockwise.

Bit 1, Run Rev:

Bit 1 = "0" leads to a stop of the motor. Bit 1 = "1" leads to a start of the motor.

Bit 2, Fault Reset:

Bit 2 = "0" means that there is no trip reset. Bit 2 = "1" means that a trip is reset.

Bit 3, No function:

Bit 3 has no function.

Bit 4, No function:

Bit 4 has no function.

Bit 5, Net Control:

Bit 5 = "0" means that the drive is controlled from the standard inputs. Bit 5 = "1" means that EIP controls the drive.

NOTE!
Please note that changes will affect parameters O-50 to O-56.

Bit 6, Net Reference:

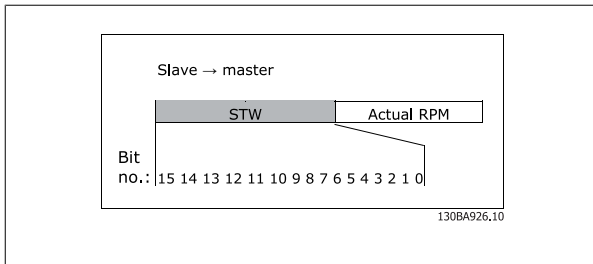
Bit 6 = "0" Reference is from the standard inputs. Bit 6 = "1" Reference is from EIP.

NOTE!
Please note that changes will affect par. F-01 *Frequency Setting 1*, par. C-30 *Frequency Command 2*, and par. C-34 *Frequency Command 3*. For the speed reference, see section *Bus speed reference value under Instances 20/70 and 21/71*.



5.3.2 Status Word under Instances 20/70 and 21/71

The status word in Instances 70 and 71 is defined as follows:



NOTE!
Bits 00 and 02 in Instance 70 are identical with bits 00 and 02 in the more extensive Instance 71.

Bit	Instance 70		Instance 71	
	Bit = 0	Bit = 1	Bit = 0	Bit = 1
00	No Fault	Fault	No Fault	Fault
01	-	-	-	Warning
02	-	Running 1 Fwd	-	Running 1 Fwd
03	-	-	-	Running 2 Rev.
04	-	-	-	Ready
05	-	-	-	Ctrl from Net
06	-	-	-	Ref. from Net
07	-	-	-	At ref.
08-15	-	-	State Attribute	

Explanation of the Bits:

Bit 0, Fault:

Bit 0 = "0" means that there is no fault in the adjustable frequency drive. Bit 0 = "1" means that there is a fault in the adjustable frequency drive.

Bit 1, Warning:

Bit 0 = "0" means that there is no unusual situation. Bit 0 = "1" means that an abnormal condition has occurred.

Bit 2, Running 1:

Bit 2 = "0" means that the drive is not in one of these states or that Run 1 is not set. Bit 2 = "1" means that the drive state attribute is enabled or stopping, or that fault stop and bit 0 (Run 1) of the control word are set at the same time.

Bit 3, Running 2:

Bit 3 = "0" means that the drive is in neither of these states or that Run 2 is not set. Bit 3 = "1" means that the drive state attribute is enabled or stopping, or that fault stop and bit 0 (Run 2) of the control word are set at the same time.

Bit 4, Ready:

Bit 4 = "0" means that the state attribute is in another state. Bit 4 = "1" means that the state attribute is ready, enabled or stopping.

Bit 5, Control from net:

Bit 5 = "0" means that the drive is controlled from the standard inputs. Bit 5 = "1" means that EIP has control (start, stop, reverse) of the drive.

Bit 6, Ref from net:

Bit 6 = "0" means that the reference comes from inputs to the drive. Bit 6 = "1" means that the reference comes from EIP.

Bit 7, At reference:

Bit 7 = "0" means that the motor is running, but that the present speed is different from the preset speed reference, i.e., the speed is being accelerated/decelerated during start/stop. Bit 7 = "1" means that the drive and reference speeds are equal.

Bit 8 - 15, State attribute:

(Instance 71 only) Represents the state attribute of the drive as indicated in the following table:

Bit Number	Meaning
8	(Vendor specific)
9	Start up
10	Not ready
11	Ready
12	Enabled
13	Stopping
14	Fault stop
15	Faulted

For more detail of the actual output speed, see the section *Actual output speed under Instances 20/70 and 21/71*.



5.4 Reference Handling

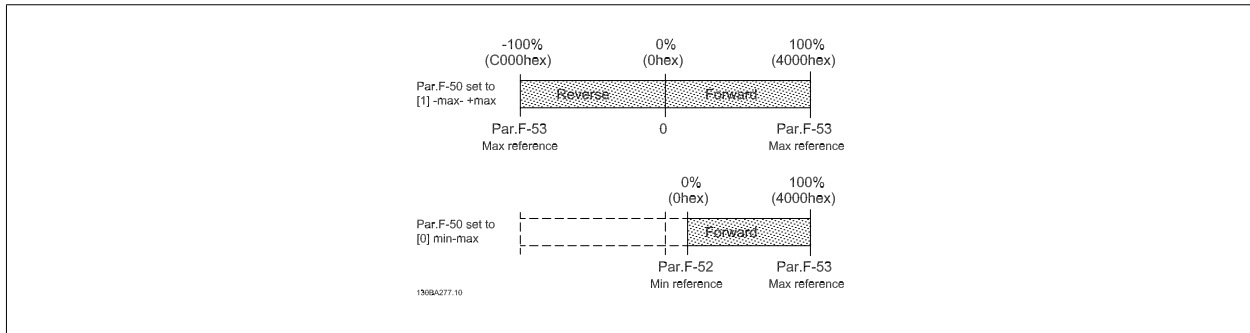
5.4.1 Bus Speed Reference Value under Instances 100-101-103/150-151-153

In Drive Profile (par. O-10 = [0] Drive profile), the reference is scaled as a normalized relative value in percent. The value is transmitted in hexadecimal:

- 0% = 0hex
- 100% = 4000hex
- 100% = C000hex

Depending of the setting of par. F-50 *Reference Range*, the reference is scaled from – Max. to + Max. or from Min. to Max.

5



The actual reference [Ref. %] in the drive depends on the settings in the following parameters:

- Par. F-04 *Base Frequency*
- Par. P-06 *Base Speed*
- Par. F-52 *Minimum Reference*
- Par. F-53 *Maximum Reference*

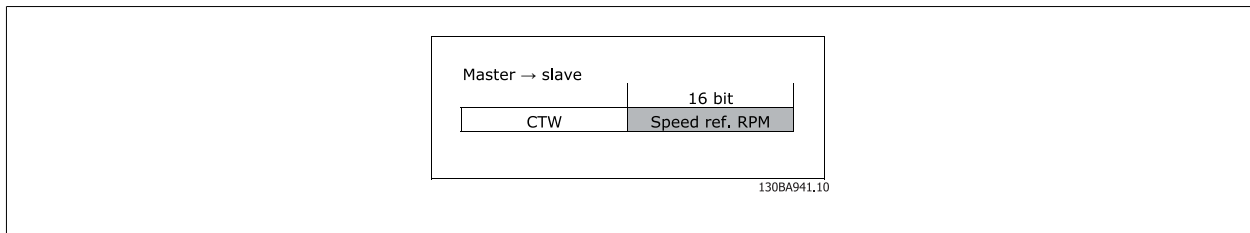
All references provided to the adjustable frequency drive are added to the total reference value. If a reference is to be controlled by the network only, ensure that all other reference inputs are zero.

This means that digital and analog input terminals should not be used for reference signals. The default setting (0%) should be maintained for preset references in par. C-05 *Multi-step Frequency 1 - 8*.

NOTE!
 If the bus speed reference is negative and the control word contains a run reverse signal, the drive will run clockwise (- is +).

MAV is scaled in the same way as the reference.

5.4.2 Bus Speed Reference Value under Instances 20/70 and 21/71



The speed reference value should be transmitted to the drive in the form of a 16-bit word. The value is transmitted directly in RPM.



6 Parameters

6.1 Parameter Group O-##

O-01 Control Site

Option:
Function:

The setting in this parameter overrides the settings in par. O-50 *Coasting Select* to par. O-56 *Preset Reference Select*.

[0] *	Digital and ctrl.word	Control by using both digital input and control word.
[1]	Digital only	Control by using digital inputs only.
[2]	Controlword only	Control by using control word only.

O-02 Control Word Source

Select the source of the control word: one of two serial interfaces or four installed options. During initial power-up, the adjustable frequency drive automatically sets this parameter to *Option A* [3] if it detects a valid network option module installed in slot A. If the option is removed, the adjustable frequency drive detects a change in the configuration, sets par. O-02 *Control Word Source* back to default setting *Drive RS485*, and the adjustable frequency drive then trips. If an option is installed after initial power-up, the setting of par. O-02 *Control Word Source* will not change but the adjustable frequency drive will trip and display: Alarm 67 *Option Changed*.

This parameter cannot be adjusted while the motor is running.

Option:
Function:

[0]	None
[1]	Drive RS485
[2]	Drive USB
[3] *	Option A
[4]	Option B
[5]	Option C0
[6]	Option C1

O-03 Control Word Time-out Time

Range:
Function:

1.0 s* [0.1 - 18000.0 s]

Enter the maximum time expected to pass between the reception of two consecutive messages. If this time is exceeded, it indicates that the serial communication has stopped. The function selected in par. O-04 *Control Word Time-out Function* will then be carried out. The timeout counter is triggered by a valid control word.

O-04 Control Word Time-out Function

Select the timeout function. The timeout function activates when the control word fails to be updated within the time period specified in par. O-03 *Control Word Time-out Time*.

Option:
Function:

[0] *	Off	Resumes control via serial bus (network or standard) using the most recent control word.
[1]	Freeze output	Freezes output frequency until communication resumes.
[2]	Stop	Stops with auto-restart when communication resumes.
[3]	Jogging	Runs the motor at JOG frequency until communication resumes.
[4]	Max. speed	Runs the motor at maximum frequency until communication resumes.
[5]	Stop and trip	Stops the motor, then resets the adjustable frequency drive in order to restart: via the network, via the reset button on the Keypad or via a digital input.
[7]	Select set-up 1	Changes the set-up upon reestablishment of communication following a control word timeout. If communication resumes causing the timeout situation to disappear, par. O-05 <i>End-of-Time-out Function</i> de-



		finishes whether to resume the set-up used before the timeout or to retain the set-up endorsed by the timeout function.
[8]	Select set-up 2	See [7] <i>Select set-up 1</i>
[9]	Select set-up 3	See [7] <i>Select set-up 1</i>
[10]	Select set-up 4	See [7] <i>Select set-up 1</i>
[26]		

NOTE!

The following configuration is required in order to change the set-up after a timeout:
Set par. K-10 *Active Set-up* to [9] *Multi set-up* and select the relevant link in par. K-12 *This Set-up Linked to*.

O-05 End-of-Time-out Function

Option:	Function:
	Select the action after receiving a valid control word following a timeout. This parameter is active only when par. O-04 <i>Control Word Time-out Function</i> is set to [Set-up 1-4].
[0]	Hold set-up Retains the set-up selected in par. O-04 <i>Control Word Time-out Function</i> and displays a warning, until par. O-06 <i>Reset Control Word Time-out</i> toggles. Then the drive resumes its original set-up.
[1] *	Resume set-up Resumes the set-up active prior to the timeout.

O-06 Reset Control Word Time-out

This parameter is active only when *Hold set-up* [0] has been selected in par. O-05 *End-of-Time-out Function*.

Option:	Function:
[0] *	Do not reset Retains the set-up specified in par. O-04 <i>Control Word Time-out Function</i> , following a control word timeout.
[1]	Do reset Returns the adjustable frequency drive to the original set-up following a control word timeout. The adjustable frequency drive performs the reset and then immediately reverts to the <i>Do not reset</i> [0] setting

O-10 Control Word Profile

Select the interpretation of the control and status words corresponding to the installed network. Only the selections valid for the network installed in slot A will be visible in the Keypad display.

Option:	Function:
[0] *	Drive Profile
[1]	PROFIdrive profile
[5]	ODVA
[7]	CANopen DSP 402
[8]	MCO

O-13 Configurable Status Word STW

Option:	Function:
	This parameter enables configuration of bits 12 – 15 in the status word.
[0]	No function
[1] *	Profile Default Function corresponds to the profile default selected in par. O-10 <i>Control Word Profile</i> .
[2]	Alarm 68 Only Only set in the event of Alarm 68.
[3]	Trip excl Alarm 68 Set in the event of a trip, except if the trip is executed by Alarm 68.
[16]	T37 DI status The bit indicates the status of terminal 37. "1" indicates T37 is high (normal)

**O-14 Configurable Control Word CTW****Option:****Function:**

Selection of control word bit 10 if it is active low or active high

[0]	None
[1] *	Profile default
[2]	CTW Valid, act. low

O-50 Coasting Select**Option:****Function:**

Select control of the coasting function via the terminals (digital input) and/or via the network.

[0]	Digit Input	Activates Coast command via a digital input.
[1]	Bus	Activates Coast command via the serial communication port or network option module.
[2]	Logic AND	Activates Coast command via the network/serial communication port, AND additionally via one of the digital inputs.
[3] *	Logic OR	Activates Coast command via the network/serial communication port OR via one of the digital inputs.

NOTE!This parameter is active only when par. O-01 *Control Site* is set to [0] *Digital and control word*.**O-51 Quick Stop Select**

Select control of the quick stop function via the terminals (digital input) and/or via the network.

Option:**Function:**

[0]	Digital Input	Activates Quick Stop command via a digital input.
[1]	Bus	Activates Quick Stop command via the serial communication port or network option module.
[2]	Logic AND	Activates Quick Stop command via the network/serial communication port, AND additionally via one of the digital inputs.
[3] *	Logic OR	Activates Quick Stop command via the network/serial communication port OR via one of the digital inputs.

NOTE!This parameter is active only when par. O-01 *Control Site* is set to [0] *Digital and control word*.**O-52 DC Brake Select****Option:****Function:**

Select control of the DC brake via the terminals (digital input) and/or via the network.

[0]	Digit Input	Activates DC brake command via a digital input.
[1]	Bus	Activates DC brake command via the serial communication port or network option module.
[2]	Logic AND	Activates DC brake command via the network/serial communication port, AND additionally via one of the digital inputs.
[3] *	Logic OR	Activates DC brake command via the network/serial communication port OR via one of the digital inputs.

NOTE!This parameter is active only when par. O-01 *Control Site* is set to [0] *Digital and control word*.

**O-53 Start Select**

Option:	Function:
	Select control of the drive start function via the terminals (digital input) and/or via the network.
[0] Digit Input	Activates Start command via a digital input.
[1] Bus	Activates Start command via the serial communication port or network option module.
[2] Logic AND	Activates Start command via the network/serial communication port, AND additionally via one of the digital inputs.
[3] * Logic OR	Activates Start command via the network/serial communication port OR via one of the digital inputs.

NOTE!

This parameter is active only when par. O-01 Control Site is set to [0] *Digital and control word*.

O-54 Reversing Select

Option:	Function:
	Select control of the adjustable frequency drive reverse function via the terminals (digital input) and/or via the network.
[0] Digital Input	Activates the reverse command via a digital input.
[1] Bus	Activates the reverse command via the serial communication port or network option module.
[2] Logic AND	Activates the reverse command via the network/serial communication port, AND additionally via one of the digital inputs.
[3] * Logic OR	Activates the reverse command via the network/serial communication port OR via one of the digital inputs.

NOTE!

This parameter is only active when par. O-01 Control Site is set to [0] *Digital and control word*.

O-55 Set-up Select

Option:	Function:
	Select control of the drive set-up selection via the terminals (digital input) and/or via the network.
[0] Digit Input	Activates the set-up selection via a digital input.
[1] Bus	Activates the set-up selection via the serial communication port or network option module.
[2] Logic AND	Activates the set-up selection via the network/serial communication port, AND additionally via one of the digital inputs.
[3] * Logic OR	Activate the set-up selection via the network/serial communication port OR via one of the digital inputs.

NOTE!

This parameter is active only when par. O-01 Control Site is set to [0] *Digital and control word*.

**O-56 Preset Reference Select****Option:****Function:**

		Select control of the drive Preset Reference selection via the terminals (digital input) and/or via the network.
[0]	Digit Input	Activates Preset Reference selection via a digital input.
[1]	Bus	Activates Preset Reference selection via the serial communication port or network option module.
[2]	Logic AND	Activates Preset Reference selection via the network/serial communication port, AND additionally via one of the digital inputs.
[3] *	Logic OR	Activates the Preset Reference selection via the network/serial communication port OR via one of the digital inputs.

NOTE!

This parameter is active only when par. O-01 Control Site is set to [0] Digital and control word.

6.2 Parameter Group EN-##**6****EN-00 IP Address Assignment****Option:****Function:**

		Selects the IP address assignment method.
[0] *	Manual	The IP address can be set in par. EN-01 IP Address.
[1]	DHCP	The IP address is assigned via DHCP server.
[2]	BOOTP	The IP address is assigned via BOOTP server.

EN-01 IP Address**Range:**

[000.000.000.000–255.255.255.255]

Function:

Configure the IP address of the option. Read-only if par. EN-00 set to DHCP or BOOTP.

EN-02 Subnet Mask**Range:**

[000.000.000.000–255.255.255.255]

Function:

Configure the IP subnet mask of the option. Read-only if par. EN-00 set to DHCP or BOOTP.

EN-03 Default Gateway**Range:**

[000.000.000.000–255.255.255.255]

Function:

Configure the IP default gateway of the option. Read-only if par. EN-00 set to DHCP or BOOTP.

EN-04 DHCP Server**Range:**

[000.000.000.000–255.255.255.255]

Function:

Read only. Displays the IP address of the found DHCP or BOOTP server.

NOTE!

A power cycle is necessary after setting the IP parameters manually.

EN-05 Lease Expires**Range:**

[dd:hh:mm:ss]

Function:

Read only. Displays the lease time left for the current DHCP-assigned IP address.

EN-06 Name Servers**Option:****Function:**

		IP addresses of Domain Name Servers. Can be automatically assigned when using DHCP.
[0]	Primary DNS	
[1]	Secondary DNS	

**EN-07 Domain Name****Range:**

Blank [0-19 characters]

Function:

Domain name of the attached network. Can be automatically assigned when using DHCP.

EN-08 Host Name**Range:**

Blank [0-19 characters]

Function:

Logical (given) name of option.

EN-09 Physical Address**Range:**

[00:1B:08:00:00:00-00:1B:08:FF:FF:FF]

Function:

Read only. Displays the Physical (MAC) address of the option.

EN-1# Ethernet Link Parameters**Option:**[0] Port 1
[1] Port 2**Function:**

Applies for whole parameter group.

EN-10 Link Status**Option:**[0] No link
[1] Link**Function:**

Read only. Displays the link status of the Ethernet ports.

EN-11 Link Duration**Option:**

Link Duration Port 1 (dd:hh:mm:ss)

Function:

Read only. Displays the duration of the present link on each port in dd:hh:mm:ss.

EN-12 Auto Negotiation**Option:**[0] Off
[1] On**Function:**

Configures Auto Negotiation of Ethernet link parameters for each port, ON or OFF.

Link Speed and *Link Duplex* can be configured in par. EN-13 and EN-14.**EN-13 Link Speed****Option:**[0] * None
[1] 10 Mbps
[2] 100 Mbps**Function:**

Forces the link speed for each port at 10 or 100 Mbps. If par. EN-12 is set to ON, this parameter is read-only and displays the actual link speed. "None" is displayed if no link is present.

EN-14 Link Duplex**Option:**[0] Half duplex
[1] * Full duplex**Function:**

Forces the duplex for each port to full or half duplex. If par. EN-12 is set to ON, this parameter is read-only.

**EN-20 Control Instance****Range:**

[None, 20, 21, 100, 101, 103]

Function:

Read only. Displays the originator-to-target connection point. If no CIP connection is present, "None" is displayed.

EN-21 Process Data Config Write**Range:**

[[0-9] PCD read 0-9]

Function:

Configuration of readable process data.

NOTE!

For configuration of 2-word (32-bit) parameter read/write, use 2 consecutive arrays in par. EN-21 and EN-22.

EN-22 Process Data Config Read**Range:**

[[0-9] PCD read 0-9]

Function:

Configuration of readable process data.

EN-28 Store Data Values**Option:****Function:**

This parameter activates a function that stores all parameter values in the non-volatile memory (EEPROM) thus retaining parameter values at power-down. The parameter returns to "Off".

[0] * Off

The store function is inactive.

[1] Store all set-ups

All parameter value will be stored in the non-volatile memory in all four set-ups.

EN-29 Store Always**Option:****Function:**

Activates function that will always store received parameter data in non-volatile memory (EEPROM).

[0] * Off

[1] On

EN-30 Warning Parameter**Range:**

[0000-FFFF hex]

Function:

Read only. Displays the EtherNet/IP specific 16-bit status word.

Bit	Description
0	Owned
1	Not used
2	Configured
3	Not used
4	Not used
5	Not used
6	Not used
7	Not used
8	Minor recoverable fault
9	Minor unrecoverable fault
10	Major recoverable fault
11	Major unrecoverable fault
12	Not used
13	Not used
14	Not used
15	Not used

**EN-31 Net Reference**

Option:	Function:
[0] * Off	Read only. Displays the reference source in Instance 21/71. Reference from the network is not active.
[1] On	Reference from the network is active.

EN-32 Net Control

Option:	Function:
[0] * Off	Read only. Displays the control source in Instance 21/71. Control via the network is not active.
[1] On	Control via the network is active

EN-33 CIP Revision

Option:	Function:
[0] Major version (00-99)	Read only. Displays the CIP version of the option software.
[1] Minor version (00-99)	

EN-34 CIP Product Code

Range:	Function:
1100 [0 - 9999] (AF-650 GP) 1110 (AF-650 GP)*	Read only. Displays the CIP product code.

EN-37 COS Inhibit Timer

Range:	Function:
[0-65.535 ms]	Read-only Change-Of-State inhibit timer. If the option is configured for COS operation, this inhibit timer can be configured in the Forward Open message to prevent that continuously changing PCD data generates extensive network traffic. The inhibit time is in milliseconds, 0 = disabled.

EN-38 COS Filters

Range:	Function:
[[0-9] Filter 0-9 (0000-FFFFhex)]	Change-Of-State PCD filters. Sets up a filter mask for each word of process data when operating in COS mode. Single bits in the PCDs can be filtered in/out.

EN-80 FTP Server

Option:	Function:
[0] * Disable	Disables the built-in FTP server.
[1] Enable	Enables the built-in FTP server.

EN-81 HTTP Server

Option:	Function:
[0] * Disable	Disables the built-in HTTP (web) server.
[1] Enable	Enables the built-in HTTP (web) server.

EN-82 SMTP Service

Option:	Function:
[0] * Disable	Disables the SMTP (e-mail) service on the option.
[1] Enable	Enables the SMTP (e-mail) service on the option.

**EN-89 Transparent Socket Channel Port****Range:**

0* [0 – 9999]

Function:

Configures the TCP port number for the transparent socket channel. This enables drive messages to be sent transparently on Ethernet via TCP. Default value is 4000, 0 means disabled.

EN-90 Cable Diagnostics**Option:****Function:**

Enables/disables advanced cable diagnosis function. If enabled, the distance to cable errors can be read out in par. EN-93. The parameter resumes to the default setting of Disable after the diagnostics have finished.

[0] * Disable

[1] Enable

NOTE!

The cable diagnostics function will only be issued on ports where there is no link (see par. EN-10, *Link Status*)

EN-91 Auto Cross-Over**Option:****Function:**

[0] Disable

Disables the auto cross-over function.

[1] * Enable

Enables the auto cross-over function.

NOTE!

Disabling of the auto cross-over function will require crossed Ethernet cables for daisy-chaining the options.

EN-92 IGMP Snooping**Option:****Function:**

This prevents flooding of the Ethernet protocol stack by only forwarding multicast packets to ports that are a member of the multicast group

[0] Disable

Disables the IGMP snooping function.

[1] * Enable

Enables the IGMP snooping function.

EN-93 Cable Error Length**Option:****Function:**

If Cable Diagnostics is enabled in par. EN-90, the built-in switch is enabled via Time Domain Reflectometry (TDR). This is a measurement technique which detects common cabling problems such as open circuits, short circuits and impedance mismatches or breaks in transmission cables. The distance from the option to the error is displayed in meters [feet] with an accuracy of +/- 2 m [6.5 ft]. The value 0 means no errors detected.

[0] Error length Port 1 (0–200 m [0–656 ft])

[1] Error length Port 2 (0–200 m [0–656 ft])

**EN-94 Broadcast Storm Protection****Option:****Function:**

The built-in switch is capable of protecting the switch system from receiving too many broadcast packages, which can use up network resources. The value indicates a percentage of the total bandwidth that is allowed for broadcast messages.

Example:

The "OFF" means that the filter is disabled, and all broadcast messages will be passed through. The value "0%" means that no broadcast messages will be passed through. A value of "10%" means that 10% of the total bandwidth is allowed for broadcast messages. If the amount of broadcast messages increases above the 10% threshold, they will be blocked.

[0] Protection Value Port 1 (*Off – 20%)

[1] Protection Value Port 2 (*Off – 20%)

EN-95 Broadcast Storm Filter**Option:****Function:**

Applies to par. EN-94 if broadcast storm protection should also include Multicast messages.

[0] Broadcast only

[1] Broadcast & Multicast

EN-98 Interface Counters**Option:****Function:**

Read only. Advanced interface counters from the built-in switch can be used for low-level troubleshooting. The parameter shows the sum of port 1 + port 2.

[0] In Octets

[1] In Unicast Packets

[2] In Non-Unicast Packets

[3] In Discards

[4] In Errors

[5] In Unknown Protocols

[6] Out Octets

[7] Out Unicast Packets

[8] Out Non-Unicast Packets

[9] Out Discards

[10] Out Errors

**EN-99 Media Counters****Option:****Function:**

Read only. Advanced interface counters from the built-in switch can be used for low-level troubleshooting. The parameter shows the sum of port 1 + port 2.

[0]	Alignment Errors
[1]	FCS Errors
[2]	Single Collisions
[3]	Multiple Collisions
[4]	SQE Test Errors
[5]	Deferred Errors
[6]	Late Collisions
[7]	Excessive Collisions
[8]	MAC Transmit Errors
[9]	Carrier Sense Errors
[10]	Frame Too Long
[11]	MAC Receive Errors



6.3.1 O-## Options/Comms

Par. No. #	Parameter description	Default value	4 set-up	Change during operation	Conversion index	Type
O-0#						
O-01	Control Site	null	All set-ups	TRUE	-	Uint8
O-02	Control Word Source	null	All set-ups	TRUE	-	Uint8
O-03	Control Word Timeout Time	ExpressionLimit	1 set-up	TRUE	-1	Uint32
O-04	Control Word Timeout Function	[0] Off	1 set-up	TRUE	-	Uint8
O-05	End-of-Timeout Function	[1] Resume set-up	1 set-up	TRUE	-	Uint8
O-06	Reset Control Word Timeout	[0] Do not reset	All set-ups	TRUE	-	Uint8
O-07	Diagnosis Trigger	[0] Disable	2 set-ups	TRUE	-	Uint8
O-1#						
O-10	Control Word Profile	[0] Drive Profile	All set-ups	TRUE	-	Uint8
O-13	Configurable Status Word STW	[1] Profile Default	All set-ups	TRUE	-	Uint8
O-14	Configurable Control Word CTW	[1] Profile Default	All set-ups	TRUE	-	Uint8
O-3#						
O-30	Protocol	null	1 set-up	TRUE	-	Uint8
O-31	Address	ExpressionLimit	1 set-up	TRUE	0	Uint8
O-32	Drive Port Baud Rate	null	1 set-up	TRUE	-	Uint8
O-33	Drive Port Parity	null	1 set-up	TRUE	-	Uint8
O-35	Minimum Response Delay	ExpressionLimit	1 set-up	TRUE	-3	Uint16
O-36	Maximum Response Delay	ExpressionLimit	1 set-up	TRUE	-3	Uint16
O-37	Maximum Inter-Char Delay	ExpressionLimit	1 set-up	TRUE	-5	Uint16
O-4#						
O-40	Message Selection	[1] Standard message 1	2 set-ups	TRUE	-	Uint8
O-5#						
O-50	Coasting Select	[3] Logic OR	All set-ups	TRUE	-	Uint8
O-52	DC Brake Select	[3] Logic OR	All set-ups	TRUE	-	Uint8
O-53	Start Select	[3] Logic OR	All set-ups	TRUE	-	Uint8
O-54	Reversing Select	null	All set-ups	TRUE	-	Uint8
O-55	Set-up Select	[3] Logic OR	All set-ups	TRUE	-	Uint8
O-56	Preset Reference Select	[3] Logic OR	All set-ups	TRUE	-	Uint8
O-8#						
O-80	Bus Message Count	0	All set-ups	TRUE	0	Uint32
O-81	Bus Error Count	0	All set-ups	TRUE	0	Uint32
O-82	Slave Messages Rcvd	0	All set-ups	TRUE	0	Uint32
O-83	Slave Error Count	0	All set-ups	TRUE	0	Uint32
O-9#						
O-90	Bus Jog 1 Speed	100 RPM	All set-ups	TRUE	67	Uint16
O-91	Bus Jog 2 Speed	200 RPM	All set-ups	TRUE	67	Uint16
O-94	Bus Feedback 1	0	1 set-up	TRUE	0	N2
O-95	Bus Feedback 2	0	1 set-up	TRUE	0	N2
O-96	Bus Feedback 3	0	1 set-up	TRUE	0	N2



6.3.2 EN-## EtherNet

Par. No. #	Parameter description	Default value	Range	Conversion index	Type
EN-0# IP Settings					
EN-00	IP Address Assignment	0.0.0.0	0 - 255	-	Unsigned 8
EN-01	IP Address	0.0.0.0	0 - 255	-	Oct. string 4
EN-02	Subnet Mask	0.0.0.0	0 - 255	-	Oct. string 4
EN-03	Default Gateway	0.0.0.0	0 - 255	-	Oct. string 4
EN-04	DHCP Server	0.0.0.0	0 - 255	-	Oct. string 4
EN-05	Lease Expires	00:00:00:00	-	-	Time diff. w/date
EN-06	Name Servers	0.0.0.0	0 - 255	-	Oct. string 4
EN-07	Domain Name	-	max. 19 ch.	-	Visible string 48
EN-08	Host Name	-	max. 19 ch.	-	Visible string 48
EN-09	Physical Address	00:1B:08:00:00:00	-	-	Visible string 17
EN-1# EtherNet Link Parameters					
EN-10	Link Status	No Link [0]	[0 - 1]	-	Unsigned 8
EN-11	Link Duration	00:00:00:00	-	-	Time diff. w/date
EN-12	Auto Negotiation	On [1]	[0 - 1]	-	Unsigned 8
EN-13	Link Speed	None [0]	[0 - 2]	-	Unsigned 8
EN-14	Link Duplex	Full Duplex [1]	[0 - 1]	-	Unsigned 8
EN-2# Process DATA					
EN-20	Control Instance	None	20 - 103	-	Unsigned 8
EN-21	Process Data Config Write	-	-	-	Unsigned 16
EN-22	Process Data Config Read	-	-	-	Unsigned 16
EN-28	Store Data Values	Off [0]	[0 - 1]	-	Unsigned 8
EN-29	Store Always	Off [0]	[0 - 1]	-	Unsigned 8
EN-3# EtherNet IP					
EN-30	Warning Parameter	0000 hex	0000-FFFF	-	Unsigned 16
EN-31	Net Control	Off [0]	[0 - 1]	-	Unsigned 8
EN-32	Net Reference	Off [0]	[0 - 1]	-	Unsigned 8
EN-33	CIP Revision	00	0 - 99	-	Unsigned 16
EN-34	CIP Product Code	0	9999	-	Unsigned 16
EN-37	COS Inhibit Timer	0	0 - 65535	0	Unsigned 16
EN-38	COS Filters	0000	0000-FFFF	-	Unsigned 16
EN-6# Other EtherNet Services					
EN-80	FTP Server	Disable [0]	[0 - 1]	-	Unsigned 8
EN-81	HTTP Server	Disable [0]	[0 - 1]	-	Unsigned 8
EN-82	SMTP Server	Disable [0]	[0 - 1]	-	Unsigned 8
EN-89	Transp. Socket Channel Port	Disable [0]	[0 - 1]	-	Unsigned 8
EN-9# Advanced EtherNet Settings					
EN-90	Cable Diagnostics	Disable [0]	[0 - 1]	-	Unsigned 8
EN-91	Auto Cross-Over	Enable [0]	[0 - 1]	-	Unsigned 8
EN-92	IGMP Snooping	Enable [0]	[0 - 1]	-	Unsigned 8
EN-93	Cable Error Length	0	0 - 200	0	Unsigned 16
EN-94	Broadcast Storm Protection	0	Off - 20%	-	Unsigned 16
EN-95	Broadcast Storm Filter	Enable [1]	[0 - 1]	-	Unsigned 8
EN-98	Interface Counters	0	0 - 65535	-	Unsigned 16
EN-99	Media Counters	0	0 - 65535	-	Unsigned 16



6.4 Data Types

6.4.1 Data Types Supported by AF-650 GP/AF-600 FP

Conversion Index

This number to the left refers to a conversion figure on the right to be used when writing or reading parameters.

Conversion Index	Conversion Factor
67	1/60
6	1000000
5	100000
4	10000
3	1000
2	100
1	10
0	1
-1	0.1
-2	0.01
-3	0.001
-4	0.0001
-5	0.00001
-6	0.000001



7 Troubleshooting

7.1.1 Step-by-step Troubleshooting

Check LEDs

The option contains two LEDs to indicate the state of the device and the network. During normal operation the MS and at least one NS LED will show a constant green light.

State	LED		Description
Standby	Green:	Flashing green	The device needs commissioning
Device operational	Green:	Solid green	The device is operational
Major recoverable fault		Flashing red	The device has detected a recoverable fault (MAR)
Major unrecoverable fault	Red:	Solid red	The device has detected a un-recoverable fault (MAU)
Self test	Red:	Flashing red/green	The EIP option is in self-test mode
	Green:		

Table 7.1: MS: Module Status

State	LED		Description
No connections	Green:	Flashing green	There are no established any CIP connections to the device
Connected	Green:	Solid green	There is established (at least) one CIP connection to the device
Connection timeout	Red:	Flashing red	One or more CIP connections has timed out
Duplicate IP	Red:	Solid red	The IP address assigned to the device is already in use
Self test	Red:	Flashing red/green	The EIP option is in self-test mode
	Green:		

Table 7.2: NS1 + NS2: Network Status (one per port)

Check Link Status

The status of the Ethernet link cannot be directly identified by means of the LEDs if no CIP connection is established.

Use par. EN-10, *Link Status* to verify presents of the link.

Use par. EN-11, *Link Duration* to verify that the link is steady present.

The parameter will show the duration of the present link, and preset to 00:00:00:00 if the link is broken.

Check: Cabling

In rare cases of cabling misconfiguration, the option might show the presents of a link, but no communication is running. Exchange the cable in doubt.

Check IP Address

Verify that the option has a valid IP address (please refer to section: IP Settings) in par. EN-01, *IP Address*. If the option has identified a duplicate IP Address NS LEDs will light steady red. If the option is set up for BOOTP or DHCP, verify that a BOOTP or DHCP server is connected in par. EN-04, *DHCP Server*. If no server is connected, the parameter will show 000.000.000.000.

7.1.2 Alarm Word and Warning Word

The alarm word and warning word are shown in the display in Hex format. If there is more than one warning or alarm, a sum of all warnings or alarms will be shown. The warning word and alarm word are displayed in par. DR-90 to DR-95. For more information on the individual alarms and warnings, please refer to AF-650 GP/AF-600 FP Design Guide.

NOTE!

Please note that the availability of the individual alarms and warnings are dependent on the drive type: AF-600 FP/AF-650 GP series.

Warning and Alarm Messages

There is a clear distinction between alarms and warnings. In the event of an alarm, the adjustable frequency drive will enter a fault condition. After the cause for the alarm has been cleared, the master must acknowledge the alarm message in order to start operation of the adjustable frequency drive again. A warning, on the other hand, may appear when a warning condition arises, then disappear when conditions return to normal without interfering with the process.

**Warnings**

All warnings within the adjustable frequency drive are represented by a single bit within a warning word. A warning word is always an action parameter. Bit status FALSE [0] means no warning, while bit status TRUE [1] means warning. Each bit status has a corresponding text string message. In addition to the warning word message, the master will also be notified via a change in the status word.

Alarms

Following an alarm message the adjustable frequency drive will enter a fault condition. Only after the fault has been rectified and the master has acknowledged the alarm message by a bit in the control word can the drive resume operation. All alarms within the drive are represented by a single bit within an alarm word. An alarm word is always an action parameter. Bit status FALSE [0] means no alarm, while bit status TRUE [1] means alarm. In CIP, alarms are divided into two categories:

- Major Recoverable Faults
- Major Unrecoverable Faults

Please refer to the following sections for a classification of the specific faults.

Bit (Hex)	Alarm word (Par. DR-90)	CIP Classification
00000001	Brake check	-
00000002	Power card overtemperature	MAR
00000004	Ground fault	MAU
00000008	Ctrl. card overtemperature	-
00000010	Control word timeout	MAR
00000020	Torque limit	MAU
00000040	Overcurrent	MAR
00000080	Motor thermistor overtemp.	MAR
00000100	Motor Electronic Thermal Overload overtemperature	MAR
00000200	Inverter overloaded	MAR
00000400	DC link undervoltage	MAR
00000800	DC link overvoltage	MAR
00001000	Short circuit	MAU
00002000	Soft-charge fault	MAR
00004000	Line phase loss	MAU
00008000	Auto Tune not OK	MAR
00010000	Live zero error	MAR
00020000	Internal fault	MAU
00040000	Brake overload	MAU
00080000	Motor phase U is missing	MAU
00100000	Motor phase V is missing	MAU
00200000	Motor phase W is missing	MAU
00400000	Network fault	MAR
00800000	24 V supply fault	MAU
01000000	Line failure	MAR
02000000	1.8 V supply fault	MAU
04000000	Brake resistor short circuit	MAR
08000000	Brake chopper fault	MAR
10000000	Option change	-
20000000	Drive initialized	-
40000000	Safe Stop	MAR
80000000	Mech. Brake low	-

MAR = Major Recoverable Fault

MAU = Major Unrecoverable Fault



Bit (Hex)	Alarm word 2 (Par DR-91)
00000001	Service Trip, Read/Write
00000002	Reserved
00000004	Service Trip, Typecode/Sparepart
00000008	Reserved
00000010	Reserved
00000020	No Flow
00000040	Dry Pump
00000080	End of Curve
00000100	Broken Belt
00000200	Discharge high
00000400	Start failed
00000800	Speed limit
00001000	Reserved
00002000	Reserved
00004000	Reserved
00008000	Reserved
00010000	Reserved
00020000	KTY error
00040000	Fans error
00080000	Reserved
00100000	Reserved
00200000	Reserved
00400000	Reserved
00800000	Reserved
01000000	Reserved
02000000	Reserved
04000000	Reserved
08000000	Reserved
10000000	Reserved
20000000	Reserved
40000000	PTC thermistor
80000000	Dangerous failure

Bit (Hex)	Warning word (Par. DR-92)
00000001	Brake check
00000002	Power card overtemperature
00000004	Ground fault
00000008	Control card overtemperature
00000010	Control word timeout
00000020	Overcurrent
00000040	Torque limit
00000080	Motor thermistor overtemp.
00000100	Motor Electronic Thermal Overload overtemperature
00000200	Inverter overloaded
00000400	DC link undervoltage
00000800	DC link overvoltage
00001000	DC link voltage low
00002000	DC link voltage high
00004000	Line phase loss
00008000	No motor
00010000	Live zero error
00020000	10 V low
00040000	Brake resistor power limit
00080000	Brake resistor short circuit
00100000	Brake chopper fault
00200000	Speed limit
00400000	Network comm. fault
00800000	24 V supply fault
01000000	Line failure
02000000	Current limit
04000000	Low temperature
08000000	Voltage limit
10000000	Encoder loss
20000000	Output frequency limit
40000000	Safe stop
80000000	Extended status word



Bit (Hex)	Warning word 2 (Par. DR-93)
00000001	Start Delayed
00000002	Stop Delayed
00000004	Clock Failure
00000008	Firemode was active
00000010	Reserved
00000020	No Flow
00000040	Dry Pump
00000080	End of Curve
00000100	Broken Belt
00000200	Discharge high
00000400	Reserved
00000800	Reserved
00001000	Reserved
00002000	Reserved
00004000	Reserved
00008000	Reserved
00010000	Reserved
00020000	KTY warning
00040000	Fans warning
00080000	Reserved
00100000	Reserved
00200000	Reserved
00400000	Reserved
00800000	Reserved
01000000	Reserved
02000000	Reserved
04000000	Reserved
08000000	Reserved
10000000	Reserved
20000000	Reserved
40000000	PTC thermistor
80000000	Reserved

Bit (Hex)	Extended status word (Par. DR-94)
00000001	Ramping
00000002	Auto Tune Running
00000004	Start CW/CCW
00000008	Slow Down
00000010	Catch Up
00000020	Feedback high
00000040	Feedback low
00000080	Output current high
00000100	Output current low
00000200	Output frequency high
00000400	Output frequency low
00000800	Brake check OK
00001000	Braking max
00002000	Braking
00004000	Out of speed range
00008000	OVC active
00010000	AC brake
00020000	Password Timelock
00040000	Password Protection
00080000	Reference high
00100000	Reference low
00200000	Local Ref./Remote Ref.
00400000	Reserved
00800000	Reserved
01000000	Reserved
02000000	Reserved
04000000	Reserved
08000000	Reserved
10000000	Reserved
20000000	Reserved
40000000	Reserved
80000000	Reserved

**Bit (Hex) Extended status word 2 (Par. DR-95)
AF-600 FP only!!**

00000001	Off
00000002	Hand/Auto
00000004	PROFibus OFF1 active
00000008	PROFibus OFF2 active
00000010	PROFibus OFF3 active
00000020	Relay 123 active
00000040	Start Prevented
00000080	Control ready
00000100	Drive ready
00000200	Quick Stop
00000400	DC Brake
00000800	Stop
00001000	Stand By
00002000	Freeze Output Request
00004000	Freeze Output
00008000	Jog Request
00010000	Jog
00020000	Start Request
00040000	Start
00080000	Start Applied
00100000	Start Delay
00200000	Sleep
00400000	Sleep Boost
00800000	Running
01000000	Bypass
02000000	Fire Mode
04000000	Reserved
08000000	Reserved
10000000	Reserved
20000000	Reserved
40000000	Reserved
80000000	Reserved





8 Appendix

8.1.1 Supported CIP Objects

As in all implementations of CIP, EtherNet/IP shares the common Object Model. Objects are a common method to describe the specific application implemented in a device.

Data is structured in Classes, Instances and Attributes:

A **class** is a group of objects with the same structure. These groups of objects within a class are called **instances**. Every instance provides the same data elements called **attributes**. Each class provides services to access data or to change the state of an object.

Class ID 0x01 Identity Object

Attribute	Access	Name	Data type	Description
1	Get	Vendor	UINT (97)	GE Drive vendor code
2	Get	Device Type	UINT (2)	AC Drive
3	Get	Product Code	UINT	Value of par. EN-34
4	Get	Revision	Struct	Value of par. EN-33
5	Get	Status	WORD	EIP status word (par. EN-30)
6	Get	Serial Number	UDINT	Serial number
7	Get	Product Name	String	Value of par. ID-40 (e.g., "AF-650 GP")
8	Get	State	UINT	0 = Non-existent 1 = Device Self Testing 2 = Standby 3 = Operational 4 = Major Recoverable Fault 5 = Major Unrecoverable Fault 6-254 = Reserved 255 = Default for Get Attribute All
9	Get	Conf. consistency value	UINT	

Table 8.1: Instance Attributes

Class ID 0x04 Assembly Objects

Instance	Access	Name	Size	Description
20	Set	ODVA basic speed control output	2 Words	
21	Set	ODVA extended speed control output	2 Words	
70	Get	ODVA basic speed control input	2 Words	
71	Get	ODVA extended speed control input	2 Words	
100	Set	GE Basic Control Output	2 Words	
101	Set	GE Extended Control Output	4 Words	
103	Set	GE Extended Control Output	10 Words	
150	Get	GE Basic Control Input	2 Words	
151	Get	GE Extended Control Input	4 Words	
153	Get	GE Extended Control Input	10 Words	

Table 8.2: Instance Attributes



Class ID 0x06 Connection Manager

Attribute	Access	Name	Data Type	Description
1	Get	Open Requests	UINT	Number of Forward Open requests received
2	Get	Open Format Rejects	UINT	Number of Forward Open requests rejected due to bad format
3	Get	Open Resource Rejects	UINT	Number of Forward Open requests rejected due to lack of resources
4	Get	Open Other Rejects	UINT	Number of Forward Open requests rejected due to other reasons
5	Get	Close Requests	UINT	Number of Forward Close requests received
6	Get	Close Format Requests	UINT	Number of Forward Close requests rejected due to bad format
7	Get	Close Other Requests	UINT	Number of Forward Close requests rejected due to other reasons
8	Get	Connection Timeouts	UINT	Number of connection timeouts
9	Get	Connection Entry List Struct of: NumCon- nEntries	INT	Number of connection entries ConnOpenBits ARRAY of BOOL List of connection data

Table 8.3: Instance Attributes

Class ID 0x28 Motor Data Object

Attribute	Access	Name	Data Type	Parameter	Description
1	Get	Number of Attributes supported	USINT	-	7
2	Get	List of attributes supported	Array of USINT	-	3,6,7,8,9,12,15
3	Get/Set	Motor Type	USINT	P-20	3: PM sync. motor (AF-650 GP only) 7: Squirrel cage induction motor
6	Get/Set	Rated Current	UINT	P-03	Unit: 100 mA
7	Get/Set	Rated Voltage	UINT	F-05	Unit: Volt
8	Get/Set	Rated Power	UDINT	P-07	Unit: Watt
9	Get/Set	Rated Frequency	UINT	F-04	Unit: Hertz
12	Get/Set	Pole Count	UINT	P-01	Number of poles in motor
15	Get/Set	Base Speed	UINT	P-06	Unit: RPM

Table 8.4: Instance Attributes

NOTE!

Class ID 0x28 is only available if ODVA profile is selected in par. O-10 *Control Word Profile*.

Class ID 0x29 Control Supervisor Object

Attribute	Access	Name	Data Type	Description
1	Get	Number of Attributes supported	USINT	12
2	Get	List of supported attributes	Array of USINT	3,4,4,5,6,7,8,9,10,11,12,13,15
3	Get/Set	Run 1 (forward)	Boolean	Drive CTW Bit 6 = Run1 XOR Run2 Drive CTW Bit15 = 0
4	Get/Set	Run 2 (reverse)	Boolean	Drive CTW Bit 6 = Run1 XOR Run2 Drive CTW Bit15 = 1
5	Get/Set	Network Control	Boolean	Parameter EN-32 value written from option
6	Get	State	USINT	The state of the CIP state machine
7	Get	Running 1	Boolean	Run1 AND bit 11 in Drive STW
8	Get	Running 2	Boolean	Run2 AND bit 11 in Drive STW
9	Get	Ready	Boolean	STATE_ENABLED or STATE_STOPPING or STATE_FAULT_STOP from state machine
10	Get	Faulted	Boolean	Bit 3 in Drive STW
11	Get	Warning	Boolean	Bit 7 in Drive STW
12	Get/Set	Fault reset	Boolean	Bit 7 in Drive CTW
13	Get	Fault Code	UINT	Mapping of par. DR-90 <i>Alarm Word</i> to CIP specific fault codes
15	Get	Control from net	Boolean	Parameter EN-31 value written from option

Table 8.5: Instance Attributes



CIP Malfunction Code	Meaning	Drive Code Alarm Word	CIP Malfunction Meaning	CIP Classification
0	No alarm	0000 0000	No fault	-
0	unused	0000 0001	No fault	-
4210	Drive overtemperature	0000 0002	Excessive Device Temperature	mar
2240	Ground fault	0000 0004	Short to ground	mau
0	unused	0000 0008	No fault	-
8100	Control word timeout	0000 0010	Communication	mir
2310	Overcurrent	0000 0020	Continuous Overcurrent	mau
8302	Torque limit	0000 0040	Torque limiting	mar
4310	Motor thermistor	0000 0080	Excess Drive Temperature	mar
4310	Motor Electronic Thermal Over-load overtemp	0000 0100	Excess Drive Temperature	mar
2311	Inverter overloaded	0000 0200	Current inside the device, No. 1	mar
3220	DC Link undervoltage	0000 0400	Undervoltage inside the device	mar
3210	DC link overvoltage	0000 0800	Overvoltage inside the device	mar
2130	Short circuiting	0000 1000	Short Circuit	mau
2213	Soft-charge fault	0000 2000	Overcurr. mar during start-up	
3130	Line phase loss	0000 4000	Phase Failure	mau
5210	Auto tune fail	0000 8000	Measurement Circuit	mir
1000	Live zero fault	0001 0000	General fault	mar
6100	Internal fault	0002 0000	Internal software fault	mau
7110	Brake resistor power limit	0004 0000	Brake Chopper	mau
3300	Motor phase U missing	0008 0000	Output voltage	mau
3300	Motor phase V missing	0010 0000	Output voltage	mau
3300	Motor phase W missing	0020 0000	Output voltage	mau
8100	Network Comm. fault	0040 0000	Communication	mir
5112	24 V supply fault	0080 0000	+24 V power supply	mau
3100	Line failure	0100 0000	AC Line Voltage	mar
5110	1.8 V supply fault	0200 0000	Low voltage power supp.	mau
7110	Brake resist. short circ.	0400 0000	Brake chopper	mar
7110	Brake chopper fault	0800 0000	Brake chopper	mar
0	unused	1000 0000	No fault	-
0	unused	2000 0000	No fault	-
0	unused	4000 0000	No fault	-
0	unused	8000 0000	No fault	-

Table 8.6: Attribute 13 "Fault Code"

Mir = Minor Recoverable

Mar = Major Recoverable

Mau = Major Unrecoverable

Service Code	Service Name	Service Description
0Eh	Get_Attribute_Single	Returns contents of specified attribute
10h	Set_Attribute_Single	Sets the contents of specified attribute
05h	Reset	Resets drive to its start-up state.

Table 8.7: Services supported

NOTE!

Class ID 0x29 is only available if ODVA profile is selected in par. O-10 *Control Word Profile*.



Class ID 0x2A AC/DC Drive Object

Attribute	Access Rule	Information about	Data Type	Contents
1	Get	Number of Attributes Supported	USINT	12
2	Get	List of Attributes Supported	USINT	3,4,6,7,8,18,19,20,21,22,28,29
3	Get	At Reference	Boolean	Bit 8 of Drive STW
4	Get/Set	Network Reference	Boolean	value written to parameter "Net Reference"
6	Get/Set	Drive Mode	USINT	Mapping of values from parameter H-40
7	Get	Actual Speed	INT	See Attribute 22
8	Get/Set	Reference Speed	INT	See Attribute 22
18	Get/Set	Acceleration Time	UINT	Scaled with Attribute 28 and written to par. F-07
19	Get/Set	Deceleration time	UINT	Scaled with Attribute 28 and written to par. F-08
20	Get/Set	Low Speed Limit	UINT	Scaled with Attribute 22 and written to par. F-18
21	Get/Set	High Speed Limit	UINT	Scaled with Attribute 22 and written to par. F-17
22	Get/Set	Speed Scale	SINT	Forms the "Speed Reference" and "Main Actual Value" for the drive together with Attribute 7 and 8
28	Get/Set	Time Scale	SINT	Scaling factor for all time attributes
29	Get	Ref From Net	Boolean	value of parameter "Net Reference"

Table 8.8: Instance Attributes

Value of Attribute 6	ODVA Text	Value of par. H-40	Drive Text
0	Vendor specific	Remaining values not listed below	?
1	Open-loop speed ctr.	0	Speed open-loop
2	Closed-loop speed ctr.	1	Speed closed-loop
3	Torque Control	NA	NA
4	Process Control	NA	NA
5	Position Control	NA	NA

Table 8.9: Attribute 6 "Drive Mode"

NOTE!

Class ID 0x2A is only available if ODVA profile is selected in par. O-10 *Control Word Profile*.

Class ID 0xF5 Interface Object

Attribute	Access Rule	Name	Data Type	Description of Attribute	Parameter In Drive
1	Get	Status	DWORD	Interface status	-
2	Get	Configuration Capability	DWORD	Interface capability flags	-
3	Get/Set	Configuration Control	DWORD	Interface control flags	-
4	Get	Physical Link Object	STRUCT of:	Path to physical link object	-
		Path size	UINT	Size of Path	-
		Path	Padded EPATH	Logical segments identifying the physical link object	-
5	Get/Set	Interface Configuration	STRUCT of:	TCP/IP network interface configuration.	-
		IP Address	UDINT	The device's IP address.	EN-01
		Network Mask	UDINT	The device's network mask.	EN-02
		Gateway Address	UDINT	Default gateway address	EN-03
		Name Server	UDINT	Primary name server	EN-06 [0]
		Name Server 2	UDINT	Secondary name server	EN-06[1]
6	Get/Set	Host Name	STRING	Host name	EN-08

Table 8.10: Instance Attributes



Class ID 0xF6 Link Object

Three instances of the link object are implemented:

- Instance 1 and 2 relates to the physical Port 1 and 2 of the option.
- Instance 3 relates to the internal interface of the option after the built-in switch.

Attribute	Access Rule	Name	Data Type	Description of Attribute	Parameter in drive
1	Get	Interface Speed	UDINT	Interface speed in Mbps (e.g., 0, 10, 100, 1000, etc.)	EN-13
2	Get	Interface Flags	DWORD	Interface status flags	-
3	Get	Physical Address	ARRAY of 6 USINTs	MAC layer address	EN-09
4	Get	Interface Counters	STRUCT of		
		In Octets	UDINT	Octets received on the interface	EN-98 [0]
		In Ucast Packets	UDINT	Unicast packets received on the interface	EN-98[1]
		In NUCast Packets	UDINT	Non-unicast packets received on the interface	EN-98[2]
		In Discards	UDINT	Inbound packets received on the interface but discarded	EN-98[3]
		In Errors	UDINT	Inbound packets that contain errors (does not include In Discards)	EN-98 [4]
		In Unknown Protos	UDINT	Inbound packets with unknown protocol	EN-98[5]
		Out Octets	UDINT	Octets sent on the interface	EN-98[6]
		Out Ucast Packets	UDINT	Unicast packets sent on the interface	EN-98[7]
		Out NUCast Packets	UDINT	Non-unicast packets sent on the interface	EN-98[8]
5	Get	Media Counters	STRUCT of:	Media-specific counters	
		Alignment Errors	UDINT	Frames received that are not an integral number of octets in length	EN-99[0]
		FCS Errors	UDINT	Frames received that do not pass the FCS check	EN-99[1]
		Single Collisions	UDINT	Successfully transmitted frames which experienced exactly one collision	EN-99[2]
		Multiple Collisions	UDINT	Successfully transmitted frames which experienced more than one collision	EN-99[3]
		SQE Test Errors	UDINT	Number of times SQE test error message is generated	EN-99[4]
		Deferred Transmissions	UDINT	Frames for which first transmission attempt is delayed because the medium is busy	EN-99[5]
		Late Collisions	UDINT	Number of times a collision is detected later than 512 bit times into the transmission of a packet	EN-99[6]
		Excessive Collisions	UDINT	Frames for which transmission fails due to excessive collisions	EN-99[7]
		MAC Transmit Errors	UDINT	Frames for which transmission fails due to an internal MAC sub layer transmit error	EN-99[8]
		Carrier Sense Errors	UDINT	Times that the carrier sense condition was lost or never asserted when attempting to transmit a frame	EN-99[9]
Frame Too Long	UDINT	Frames received that exceed the maximum permitted frame size	EN-99[10]		
MAC Receive Errors	UDINT	Frames for which reception on an interface fails due to an internal MAC sub layer receive error	EN-99[11]		
6	Set	Interface Control	STRUCT of:	Configuration for physical interface	-
		Control Bits	WORD	Interface Control Bits	-
		Forced Interface Speed	UINT	Speed at which the interface shall be forced to operate Speed in Mbps (10, 100, 1000, etc.)	-
7	Get	Interface Label	SHORT_STRING	Human readable identification	-
8	Get	Link List Size	USINT	Number of members in Link List	-
9	Get	Link List	ARRAY OF UINT	Link list between internal and all according external interfaces	-

Table 8.11: Instance Attributes



Service Code	Supported		Service Name	Description of Service
	Class	Instance		
01h	Yes	Yes	Get_Attribute_All	Returns a predefined listing of this objects attributes
0Eh	Yes	Yes	Get_Attribute_Single	Returns the contents of the specified attribute.
10h	-	Yes	Set_Attribute_Single	Modifies a single attribute.
43h	-	Yes	Get_and_Clear	Gets then clears the specified attribute (Interface Counters or Media Counters).

Table 8.12: Services supported

Class ID 0x0F Parameter Object

Attribute	Access Rule	Name	Data Type	Description of Attribute	Contents
1	Get	Revision	UINT	revision of object	01
2	Get	Max Instance	UINT	max instance number	variable
3	Get	Number of instances	UINT	amount of instances	variable
8	Get	Parameter Class Descriptor	WORD	Parameter description	0x03
9	Get	Configuration Assembly Instance	UINT	instance number of the configuration assembly	0
10	Get/Set	Native Language	USINT	Language ID for all character array accesses	variable

Table 8.13: Class attributes

Attribute	Access Rule	Name	Data type	Description	Value
1	Set/Get	Parameter Value	data type described in Attr. 5	actual value of parameter	Value of parameter from drive
2	Get	Link path size	USINT	Size of link path	variable
3	Get	Link path	ARRAY:	CIP path of parameter's origin	variable
		Segment type/port	BYTE		
		Segment Address	path		
4	Get	Descriptor	WORD	Description of parameter	See Standard
5	Get	Data Type	EPATH	Data model number	-
6	Get	Data size	USINT	Number of bytes in parameter value	variable
7	Get	Parameter name string	SHORT STRING	human-readable text string representing parameter name	Parameter Attribute From Drive
8	Get	Units string	SHORT STRING	human-readable text string representing parameter unit	Parameter Attribute From Drive
9	Get	Help String	SHORT STRING	human-readable text string representing short online help.	Parameter Attribute From Drive
10	Get	min value	data type described in Attr. 5	Generic min valid value	Parameter Attribute From Drive
11	Get	max value	data type described in Attr. 5	Generic max valid value	Parameter Attribute From Drive
12	Get	default value	data type described in Attr. 5	Generic parameter's default value	Parameter Attribute From Drive
13	Get	Scaling multiplier	UINT	multiplier for scaling factor	1
14	Get	Scaling divisor	UINT	divisor for scaling factor	1
15	Get	Scaling base	UINT	base for scaling formula	0
16	Get	Scaling offset	INT	offset for scaling formula	0
17	Get	Multiplier link	UINT	parameter instance of multiplier source	0
18	Get	divisor link	UINT	parameter instance of divisor source	0
19	Get	base link	UINT	parameter instance of base source	0
20	Get	offset link	UINT	parameter instance of offset source	0
21	Get	decimal precision	USINT	specifies parameter value format	variable

Table 8.14: Instance attributes



Service Code	Supported		Service Name	Description of Service
	Class	Instance		
0Eh	Yes	Yes	Get_Attribute_Single	returns contents of specified attribute
01h	Yes	Yes	Get_Attributes_All	returns predefined listing of object attributes
10h	No	Yes	Set_Attribute_Single	modifies attribute
4Bh	No	Yes	Get_Enum_String	reads enumerated strings from parameter instance

Table 8.15: Services supported

Class ID 0x10 Parameter Group Object

Attribute	Access Rule	Name	Data Type	Description	Contents
1	Get	Group Name String	SHORT_STRING	represents group name	Name of Group from Drive
2	Get	Number of group members	UINT	amount of parameters in group	value of n
3	Get	1st group parameter (000-099)	UINT	instance number of Parameter Object	variable
4	Get	2nd group parameter (100-199)	UINT	instance number of parameter object	variable
...	Get	...	UINT	...	variable
n+2	Get	nth group parameter	UINT	instance number of parameter object	variable

Table 8.16: Instance Attributes

Class ID 0x64 – 0xC7 GE Objects

The CIP Class ID 100 to 199 (0x64 to 0xC7) gives access to all drive parameters.

Class (decimal)	GE Parameter range
100	F-##
101	E-##
102	C-##
103	P-##
104	H-##
105	K-##
106	AN-##
107	B-##
108	O-##
109	PB-##
110	SP-##
111	XC-##
112	DR-##
...	...

The class instance and attribute act in the following way:

- 100 added to the parameter group = the value for the class.
- 100 added to the remaining parameter number = the value for the instance.
- 100 added to the array index of the parameter = the value for the attribute

Examples: (fictitious parameters)

- Parameter K-01 [index 0] = Class 100; Instance 105; Attribute 100
- Parameter H-40 [index 0] = Class 104; Instance 140; Attribute 100
- Parameter AN-54 [index 9] = Class 106; Instance 154; Attribute 109
- Parameter DN-01 [index 0] = Class 122; Instance 101; Attribute 100

All values in decimal.

All parameters are accessed in the active set-up (par. K-10 Active Set-up)



Service Code	Supported		Service Name	Description of Service
	Class	Instance		
0Eh	Yes	Yes	Get_Attribute_Single	returns contents of specified attribute
10h	No	Yes	Set_Attribute_Single	modifies attribute
4Bh	No	Yes	Get_Att_Scattered	returns specified parameter values
4Ch	No	Yes	Set_Att_Scattered	sets specified parameter values

Table 8.17: Services supported

The instructions do not purport to cover all details or variations in equipment nor to provide for every possible contingency to be met in connection with installation, operation or maintenance. Should further information be desired or should particular problems arise which are not covered sufficiently for the purchaser's purposes, the matter should be referred to the GE company.

AF-650 GP and AF-600 FP are trademarks of the General Electric Company.

GE
41 Woodford Avenue
Plainville, CT 06062

www.geelectrical.com/drives



imagination at work

130R0463



DET-625a