

# Installation Instructions

## DIN Rail Kit

### VLT<sup>®</sup> Micro Drive FC 51

The instructions provide information about installing the DIN rail kit on VLT<sup>®</sup> Micro Drive FC 51.

Only Danfoss authorized, qualified personnel is allowed to repair this equipment.

#### Safety Instructions

### **⚠ WARNING**

#### DISCHARGE TIME

The frequency converter contains DC-link capacitors which can remain charged even when the frequency converter is not powered. High voltage can be present even when the warning LED indicator lights are off. Failure to wait the specified time after power has been removed before performing service or repair work can result in death or serious injury.

- Stop the motor.
- Disconnect AC mains and remote DC-link supplies, including battery back-ups, UPS, and DC-link connections to other frequency converters.
- Disconnect or lock PM motor.
- Wait for the capacitors to discharge fully. The minimum waiting time is specified in *Table 1.1*.
- Before performing any service or repair work, use an appropriate voltage measuring device to make sure that the capacitors are fully discharged.

Size	Minimum waiting time (minutes)
M1, M2, and M3	4
M4 and M5	15

Table 1.1 Discharge Time

### **NOTICE**

#### STATIC USE ONLY

The DIN rail is designed only for static mounting and application. If placed in vibration environment, the DIN rail withstands at most 3.0 g RMS level dynamic vibration on X-Y-Z direction.

- Avoid using the DIN rail in vibration environment.

#### Installation

1. Mount the plastic part on the frequency converter.

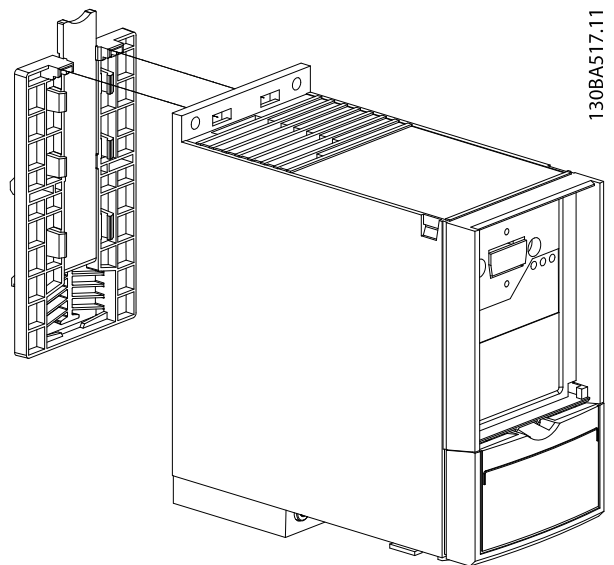

130BA517.11

Illustration 1.1 Mounting the Plastic Part

2. Fit the frequency converter on the DIN rail.

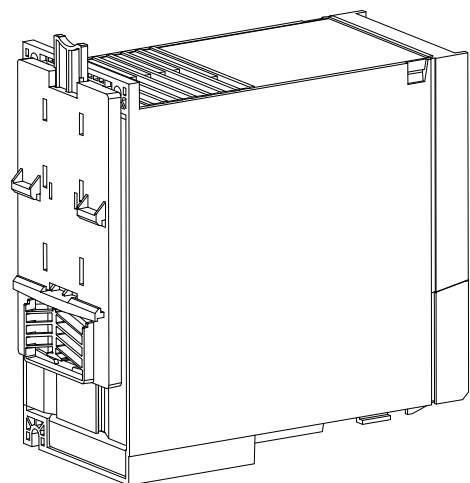

130BA518.11

Illustration 1.2 Fitting the DIN Rail

.....  
Danfoss can accept no responsibility for possible errors in catalogues, brochures and other printed material. Danfoss reserves the right to alter its products without notice. This also applies to products already on order provided that such alterations can be made without subsequential changes being necessary in specifications already agreed. All trademarks in this material are property of the respective companies. Danfoss and the Danfoss logotype are trademarks of Danfoss A/S. All rights reserved.  
.....

Danfoss A/S  
Ulsnaes 1  
DK-6300 Graasten  
[vlt-drives.danfoss.com](http://vlt-drives.danfoss.com)

