



AF-60 LP™ Nema 1 Kit Mounting Instructions for M4 and M5

Step 1

Mount metal plate on drive and tighten the screws.
Tightening torque: 2 Nm.

Conduit sizes:

3 x 1/2"

3 x 1"

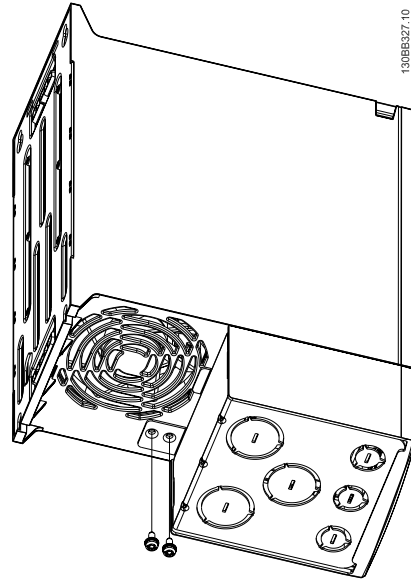

Step 2

Fit bottom cover on drive and tighten screw.

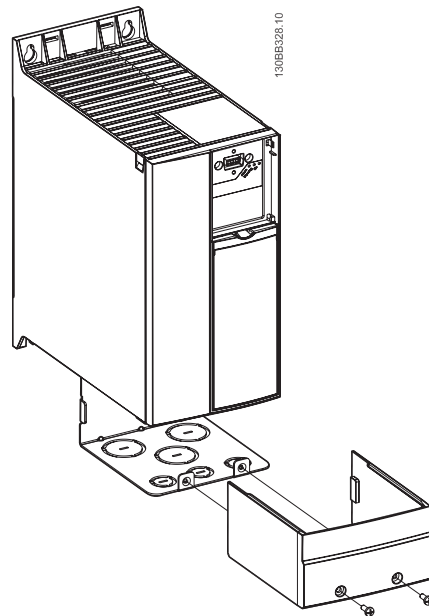

The instructions do not purport to cover all details or variations in equipment nor to provide for every possible contingency to be met in connection with installation, operation or maintenance. Should further information be desired or should particular problems arise which are not covered sufficiently for the purchaser's purposes, the matter should be referred to the GE company.

AF-60 LP is a trademark of the General Electric Company.

GE Consumer & Industrial
41 Woodford Avenue
Plainville, CT 06062

www.geelectrical.com/drives



imagination at work

130R0223



* M I Q 2 R 1 Q 2 *

DET-730