

Installation Instructions

VLT® AutomationDrive FC 302 with Connectors

1 Introduction

NOTICE

VLT® AutomationDrive FC 302 with connectors is not UL approved.

The ETR functionality is not guaranteed.

Protection rating: Enclosure IP55.

2 Safety Instructions

WARNING

DISCHARGE TIME

The frequency converter contains DC-link capacitors, that can remain charged even when the frequency converter is not powered. Failure to wait the specified time after power has been removed before performing service or repair work could result in death or serious injury.

1. Stop the motor.
2. Disconnect the AC mains, permanent magnet type motors, and remote DC-link power supplies, including battery back-ups, UPS, and DC-link connections to other frequency converters.
3. Wait for the capacitors to discharge fully, before performing any service or repair work. The minimum waiting time is specified in *Table 2.1*.

Voltage [V]	Power range [kW]	Minimum waiting time (minutes)
3x400	0.55–7.5	4
High voltage can be present even when the warning LED indicator lights are off.		

Table 2.1 Discharge Time

3 Items Supplied

Depending on the ordering number, the following is supplied:

FC 302 with 2 motor connectors (134N3195)

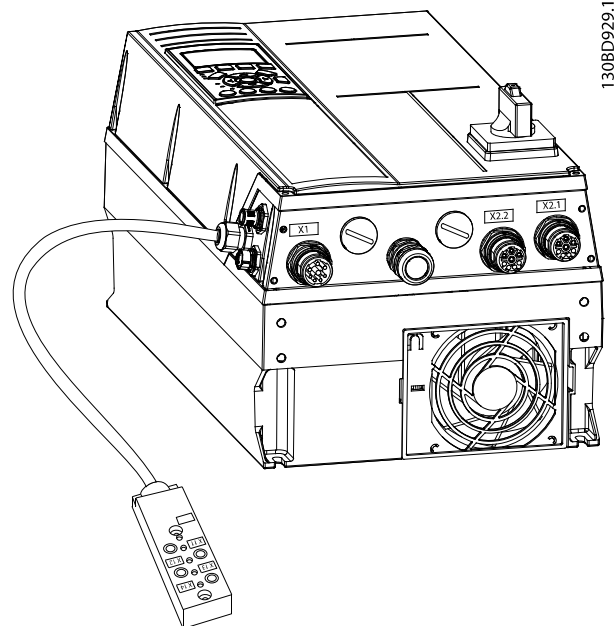

Illustration 3.1 2 Motor Connectors

FC 302 with 4 motor connectors (134N3196)

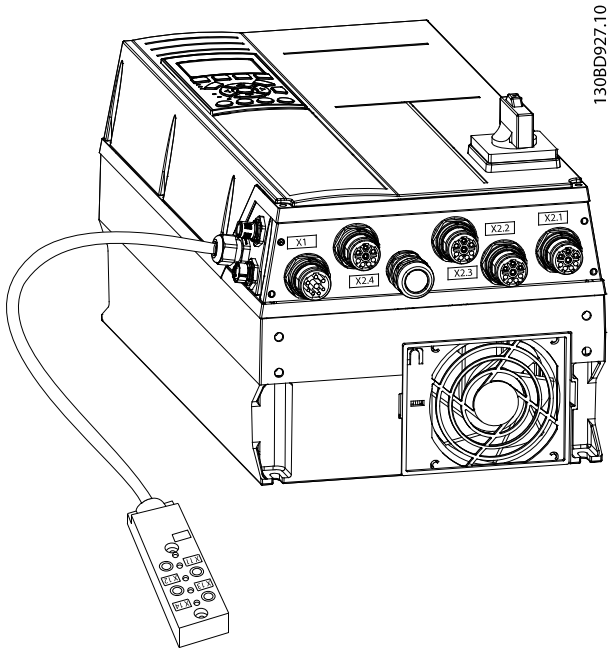

Illustration 3.2 4 Motor Connectors

FC 302 with connectors - side view

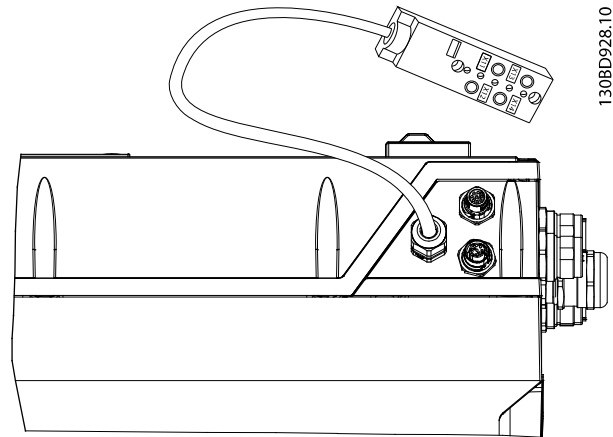

Illustration 3.4 Side View

NOTICE

See the VLT® AutomationDrive FC 302 Design Guide for dimensions and further information.

FC 302 with MCO - mains connectors and 4 cable glands (134N8410)

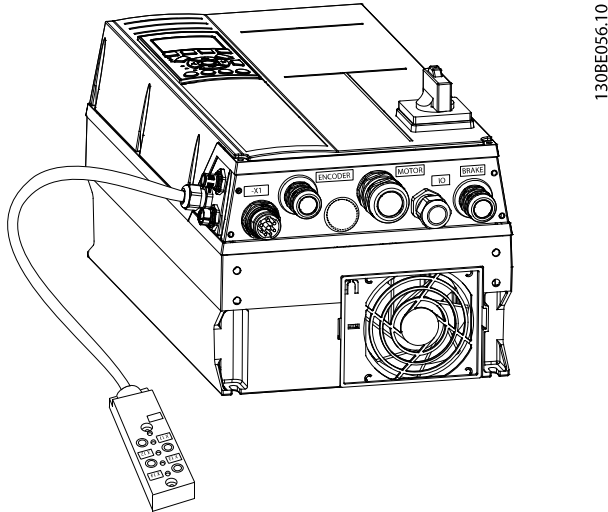

Illustration 3.3 Mains Connectors and 4 Cable Glands

4 Connectors

4.1 Overview

The frequency converter has 7 connectors plus 2 or 4 motor connectors.

Label	Connector	Description
X1	Mains	Mains in M23 (in M25) Male
X2.1-X2.4	Motor	Motor connection M23 Female
X51	PROFIBUS - Male	PROFIBUS M12
X52	PROFIBUS - Female	PROFIBUS M12
X11-X14	I/O box connector	Phoenix I/O box

Table 4.1 Connectors

4.2 X1- Mains M23 (in M25) Male

General ratings

- Pins 1, 2, 3, and 4: 480 V AC, maximum 15 A.
- Pins C and D: 30 V DC, maximum 3 A.
- Tightening torque: 1.5–2.0 Nm.

Pin	Label	Connected to frequency converter wiring schematic	Minimum wire [mm ²]
1	T1	91 (L1)	2.5
4	T2	92 (L2)	2.5
3	T3	93 (L3)	2.5
2	PE	95 (PE)	2.5
D	0 V DC	35	0.75
C	24 V DC	36	0.75

Table 4.2 Wire/Connector Assignment for Plug X1

Mating part: Mains X1 (female)

Phoenix order number: KK-0885/XX,XX

4.3 X2.1–X2.4 Motor Connectors M23 (in M25) Female

General ratings

- Pins 1, 2, 3 and, 4: 480 V AC, maximum 15 A.
- Pins C and D: 30 V DC, maximum 3 A.
- Tightening torque: 1.5–2.0 Nm.

Pin	Label	Connected to frequency converter wiring schematic	Minimum wire [mm ²]
1	U	96 (U)	2.5
3	V	97 (V)	2.5
4	W	98 (W)	2.5
2	PE	99 (PE)	2.5

Table 4.3 Wire/Connector Assignment for Plug X2

Mating part: Motor X2 (male)

Phoenix order number: KCX-K0341/XX,XX

Maximum cable length: 7.0 m

4.4 2 Motor Connection Variant (134N3195)

Keep blind plugs installed at all times to meet the protection rating.

Label	Connected to frequency converter wiring schematic
X2.1-B	53
X2.2-A	50
X2.1-A and X2.2-B	Connected to a common terminal
X2.1-C and X2.2-C	Connected to an open terminal available in the frequency converter
X2.1-D and X2.2-D	Connected to an open terminal available in the frequency converter

Table 4.4 2 Motor Connection

4.5 4 Motor Connection Variant (134N3196)

Label	Connected to frequency converter wiring schematic
X2.1-B	53
X2.4-A	50
X2.1-A and X2.2-B	Connected via an internal terminal
X2.2-A and X2.3-B	Connected via an internal terminal
X2.3-A and X2.4-B	Connected via an internal terminal

Table 4.5 4 Motor Connection

4.6 X51 PROFIBUS M12 Male, X52 PROFIBUS M12 Female

General ratings

- 30 V DC, maximum 1 A.
- Tightening torque: 0.2–0.3 Nm.

Label		Connected to frequency converter PROFIBUS connector
1	5 V DC	67
2	–	63
3	0 V DC	66
4	–	62

Table 4.6 PROFIBUS Connection

Mating part: PROFIBUS X52 and X51 (female/male)

Phoenix order number: SAC-2P-MSB/ XX,XX-910/FSB SCO CT

4.7 X11–X14 I/O Connector Box (134N3195–134N3196)

Phoenix sensor/actuator box - SACB-4/4-L-0,57HPUR CDA - 1531426.

Tightening torque sensor/actuator cable: 0.4 Nm.

Label	Wire	Connected to frequency converter wiring schematic	
X11-X14 1	Brown	12	+24 V Out
X11-X14 2			
X11-X14 3	Blue	20	COM D IN
X14-4	Grey	33	D IN
X13-4	Yellow	29	D IN/OUT
X12-4	Green	19	D IN
X11-4	White	18	D IN

Table 4.7 Connector Box (134N3195–134N3196)

4.8 X11–X14 I/O Connector Box (134N8410)

Phoenix sensor/actuator box - SACB-4/4-L-0,57HPUR CDA - 1531426.

Tightening torque sensor/actuator cable: 0.4 Nm.

Label	Wire	Connected to wiring schematic		
X11-X14 1	Brown	Connected to drive wiring schematic	12	+24V Out
X11-X14 2				
X11-X14 3	Blue		20	COM D IN
X14-4	Grey	Connected to C-option, MCO 305 wiring schematic	X57-4	–
X13-4	Yellow		X57-3	–
X12-4	Green		X57-2	–
X11-4	White		X57-1	–

Table 4.8 Connector Box (134N8410)

4.9 Overview of Marking and Cable Glands (134N8410)

Marking	Type of cable gland	Allowed cable diameter [mm]
Encoder	EMC M20x1,5 7.5-14.0	7.5-14.0
Motor	EMC M25x1,5 10.0-18.0	10.0-18.0
Brake	EMC M20x1,5 7.5-14.0	7.5-14.0
I/O	M25x1.5 50.625 (plastic RAL 7035)	11-16

Table 4.9 Cable Glands (134N8410)

5 Installation

NOTICE

For installation, refer to the *VLT® AutomationDrive FC 301/FC 302 Operating Instructions*.

NOTICE

For installation of 134N8410 FC302 with MCO, also refer to the *VLT® Motion Control Option MCO 305 Operating Instructions*.

Danfoss can accept no responsibility for possible errors in catalogues, brochures and other printed material. Danfoss reserves the right to alter its products without notice. This also applies to products already on order provided that such alterations can be made without consequential changes being necessary in specifications already agreed. All trademarks in this material are property of the respective companies. Danfoss and the Danfoss logotype are trademarks of Danfoss A/S. All rights reserved.

