

# Installation Instructions

## Remote Mounting of LCP

### VLT<sup>®</sup> HVAC Drive FC 102

#### Items Supplied

- LCP cables with 2 M12 connectors (90° male connector and straight female connector). Cable lengths: 3 m, 5 m, and 10 m (10 ft, 16 ft, 33 ft). See also *Table 1.1*.
- Blind cover with M12 female connector.
- Base plate with D-sub connector and M12 male connector.
- Two gaskets and 1 nut for the D-sub connector.
- Intermediate cover with the front cover.
- Disassembly tool.

Length [m (ft)]	Ordering number
3 (10)	134b5223
5 (16)	134b5224
10 (33)	134b5225

Table 1.1 Cable Ordering Numbers

#### More Items Required

- Local control panel (LCP).
- Four M4 self-tapping screws for mounting.

#### **NOTICE**

This instruction is valid for frequency converters that were ordered with the LCP. Front covers of frequency converters that were ordered without LCPs do not have holes for mounting the blind covers.

#### Safety Instructions

For important information about safety precautions for installation, refer to the product-specific *operating guide*.

#### **⚠ WARNING**

##### DISCHARGE TIME

The frequency converter contains DC-link capacitors, which can remain charged even when the frequency converter is not powered. High voltage can be present even when the warning LED indicator lights are off. Failure to wait the specified time after power has been removed before performing service or repair work can result in death or serious injury.

- Stop the motor.
- Disconnect AC mains and remote DC-link power supplies, including battery back-ups, UPS, and DC-link connections to other frequency converters.
- Disconnect or lock PM motor.
- Wait for the capacitors to discharge fully. The minimum duration of waiting time is specified in *Table 1.2*.
- Before performing any service or repair work, use an appropriate voltage measuring device to make sure that the capacitors are fully discharged.

Voltage [V]	Minimum waiting time (minutes)		
	4	7	15
200–240	1.1–3.7 kW (1.5–5 hp)	–	5.5–45 kW (7.5–60 hp)
380–480	1.1–7.5 kW (1.5–10 hp)	–	11–90 kW (15–125 hp)
525–600	1.1–7.5 kW (1.5–10 hp)	–	11–90 kW (15–125 hp)
525–690	–	1.1–7.5 kW (1.5–10 hp)	11–90 kW (15–125 hp)

Table 1.2 Discharge Time, FC 102

## Mechanical Installation

### **NOTICE**

The guidelines in this instruction are applicable for a frequency converter in a standard configuration without any modifications.

#### Installing the blind cover

1. Remove the front cover from the frequency converter and then remove the LCP, see *Illustration 1.1*.

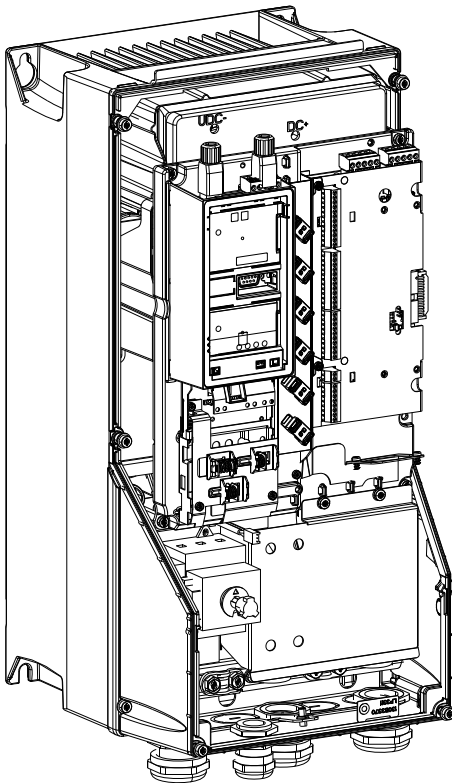

130BF903.10

Illustration 1.1 Frequency Converter with the LCP Removed

2. Install the blind cover with the gasket and the M12 connector.
3. Install the front cover on the frequency converter, see *Illustration 1.2*.

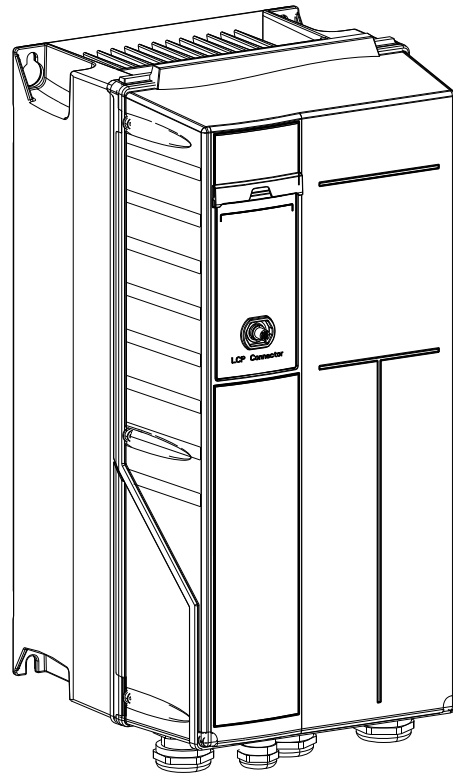

130BF901.10

Illustration 1.2 Frequency Converter with the Blind Cover

### Mounting the remote LCP

1. Drill the hole in the wall that holds the LCP. The hole diameter: 24 mm +/-1 mm (1 in +/-0.04 in). To ensure that the base plate adjoins the wall, drill the hole perpendicular to the wall (+/-1°). The kit is suitable for insulated walls 30–90 mm (1.2–3.5 in) thick and solid walls 1–20 mm (0.04–0.8 in) thick.
2. Install the base plate with the D-sub connector. Use the gasket and 4 self-tapping screws to secure the plate. See *Illustration 1.3*.

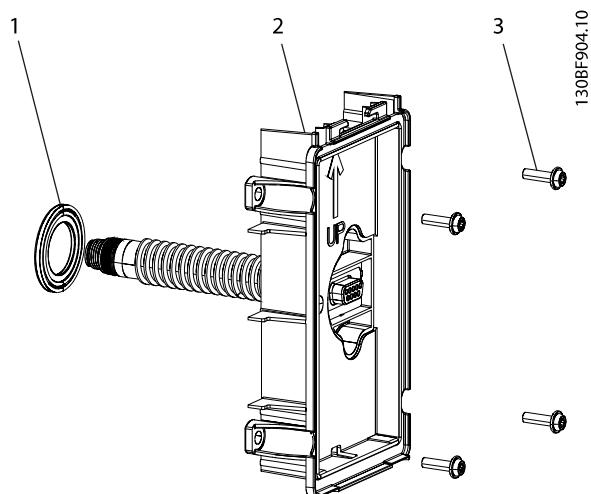

1	Gasket
2	Base plate
3	Screws

Illustration 1.3 Base Plate with D-sub Connector

3. Put the nut on the D-sub connector and tighten it with torque of 1.5 Nm (13 in-lb). Ensure that the base plate and the nut are tight on both sides of the wall. For very thin walls, the nut can also be turned 180°. See *Illustration 1.4* and *Illustration 1.5*.

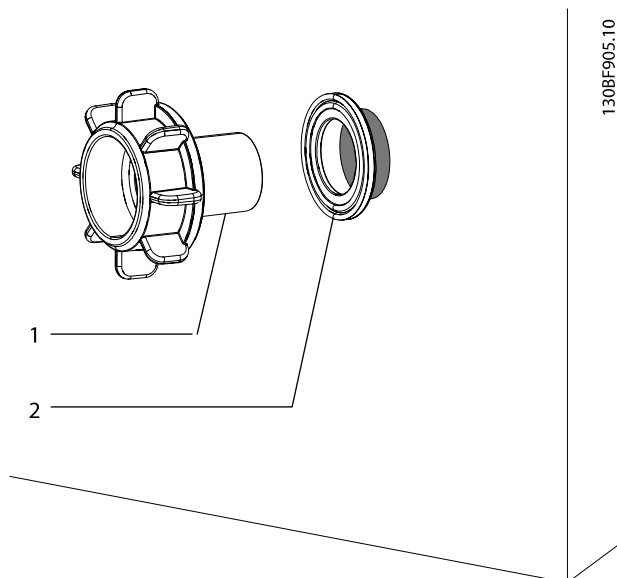

1	Nut
2	Gasket

Illustration 1.4 The Nut, Standard Position, for Thick/Insulated Walls

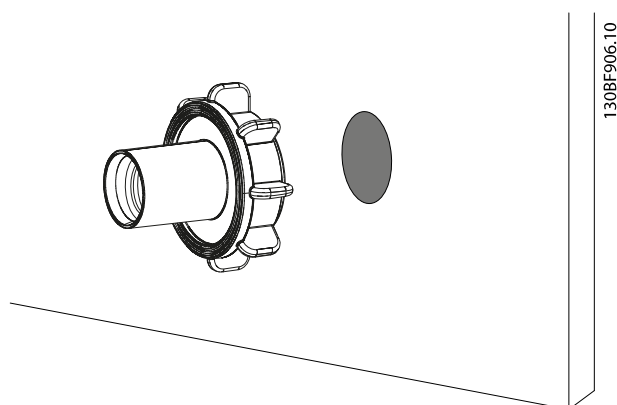
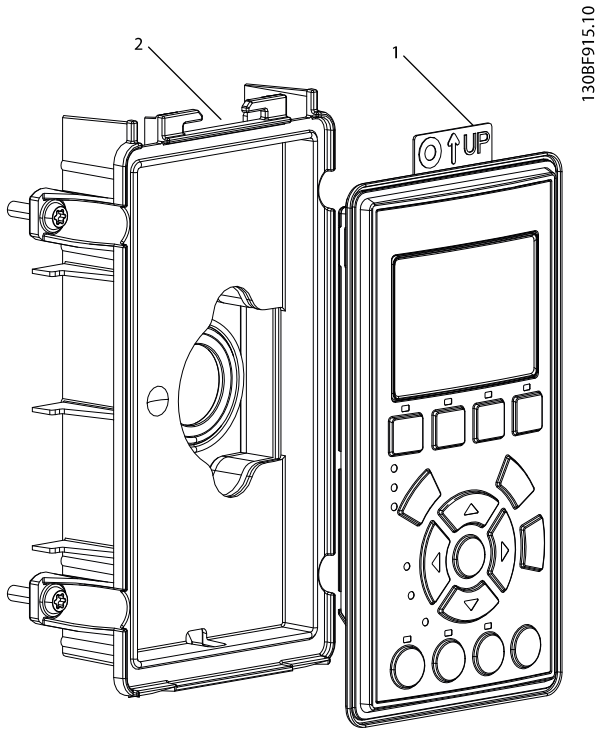

Illustration 1.5 The Nut, Turned 180°, for Thin Walls

4. Mount the LCP with the gasket on the base plate. Insert the rubber flap in the opening at the top of the cradle, see *Illustration 1.6*. *Illustration 1.7* shows the base plate with the LCP.



1	Rubber flap
2	Opening at the top of the cradle

**Illustration 1.6** Insert the Rubber Flap into the Opening

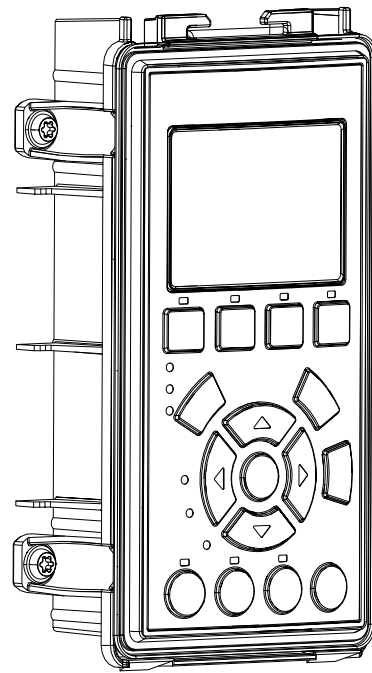

**Illustration 1.7** Base Plate with LCP

5. Mount the intermediate cover and lid on the base plate. The cover has a click-on type connection. Connect the top of the lid to the cradle and then push it until it clicks. The unit with this cover has rating IP54. See *Illustration 1.8*, and *Illustration 1.9*.

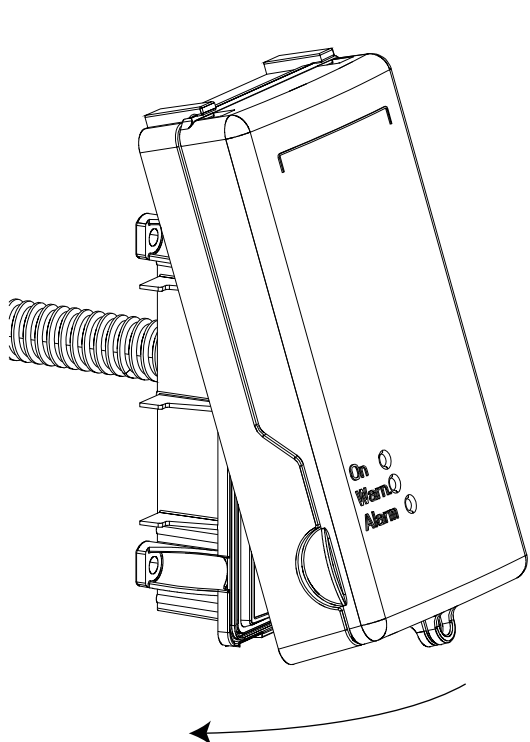

Illustration 1.8 Connect the Lid with the Front Cover

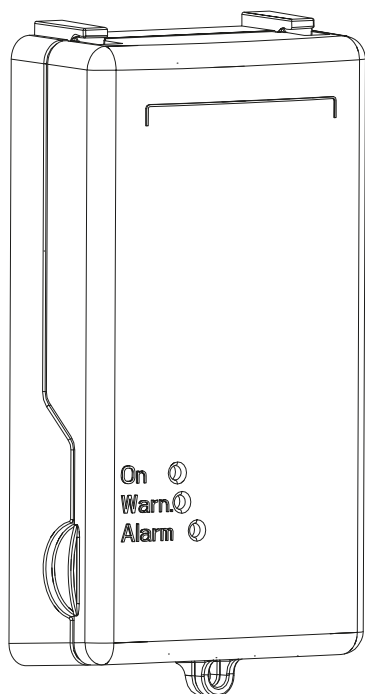

Illustration 1.9 Base Plate with the Covers

## Electrical Installation

Connect the M12 connectors on the blind cover and the LCP with the supplied cable. See *Illustration 1.10*.

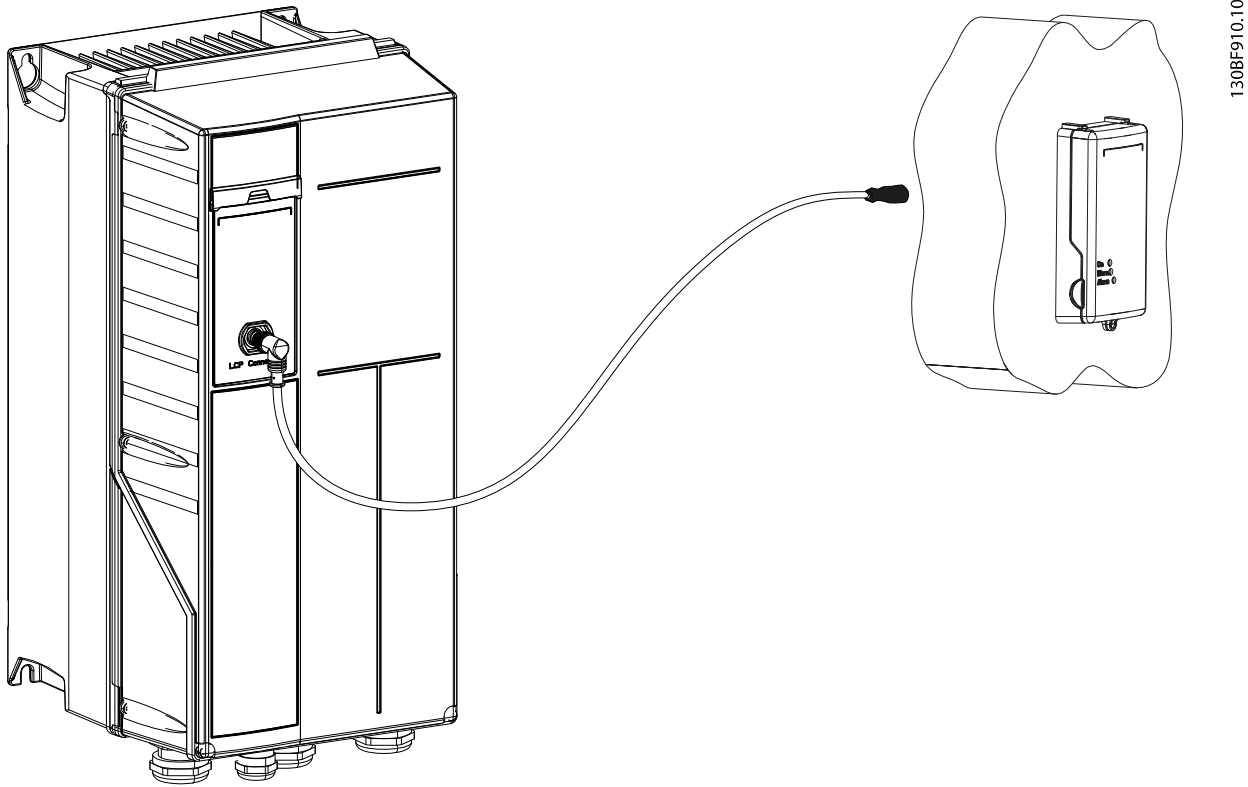
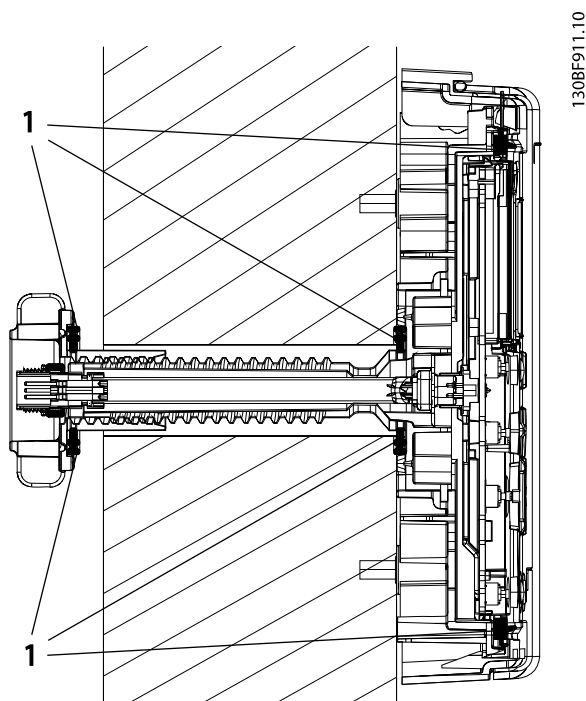

Illustration 1.10 Remote Connection of the LCP

### Areas with Gaskets on the Remote Unit

To make the remote unit more secure, the following areas are tightened with gaskets:



1	Gasket
---	--------

Illustration 1.11 Remote Unit with Gaskets

### Using the Remote LCP

The cover on the remote LCP has the following features:

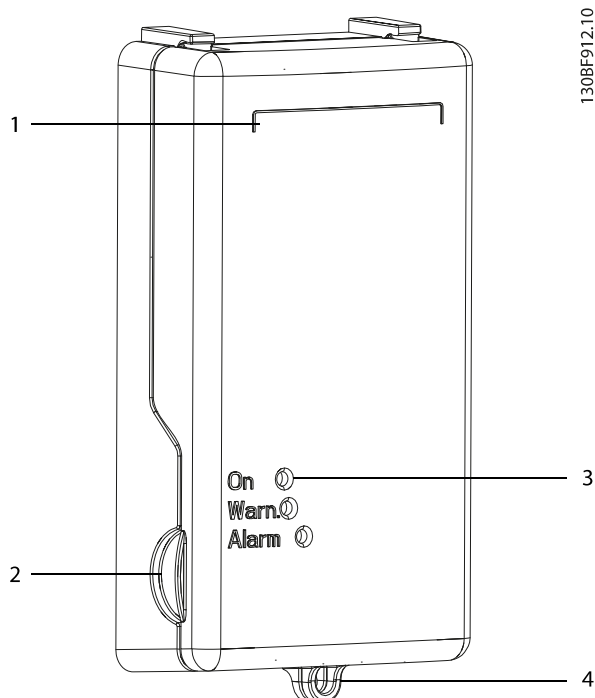

1	Place for a label
2	Groove for opening the cover
3	Openings for the indicator lights
4	Rings for locking the cover

Illustration 1.12 Remote LCP with the Cover

- The On, Warn., and Alarm indicator lights are visible with the closed front cover. Lights are visible at an angle up to 45°.
- Lock the front cover using the rings at the bottom of the cover. See *Illustration 1.14*.
- Open the front cover using the groove at the side of the cover. See *Illustration 1.13*.
- The cover has a place for a label.

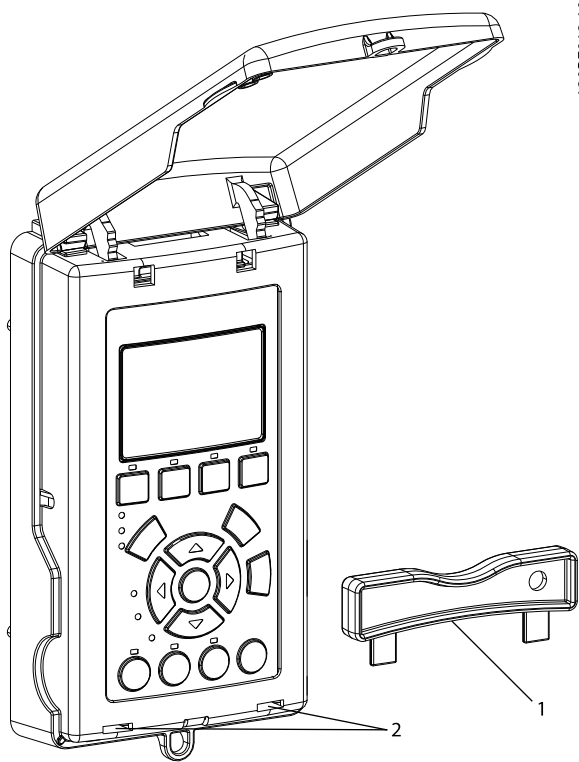

130BF913.10

1	Disassembly tool
2	Holes for the disassembly tool

Illustration 1.13 Front Cover and Disassembly Tool

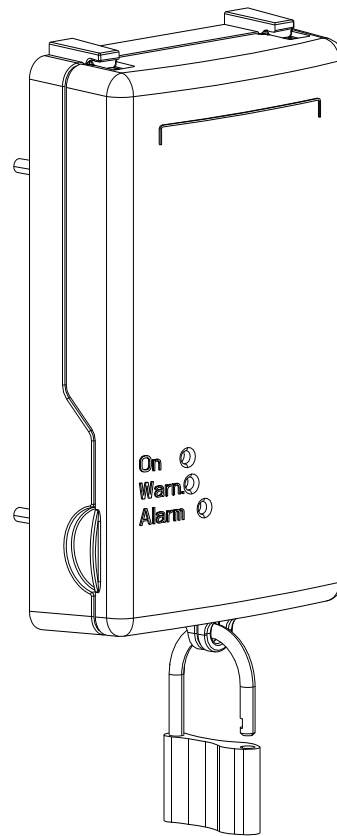

130BF914.10

Illustration 1.14 Front Cover with Padlock



### Drilling Template

Place the drilling template against the wall to mark the hole locations. The scale of the template is 1:1.

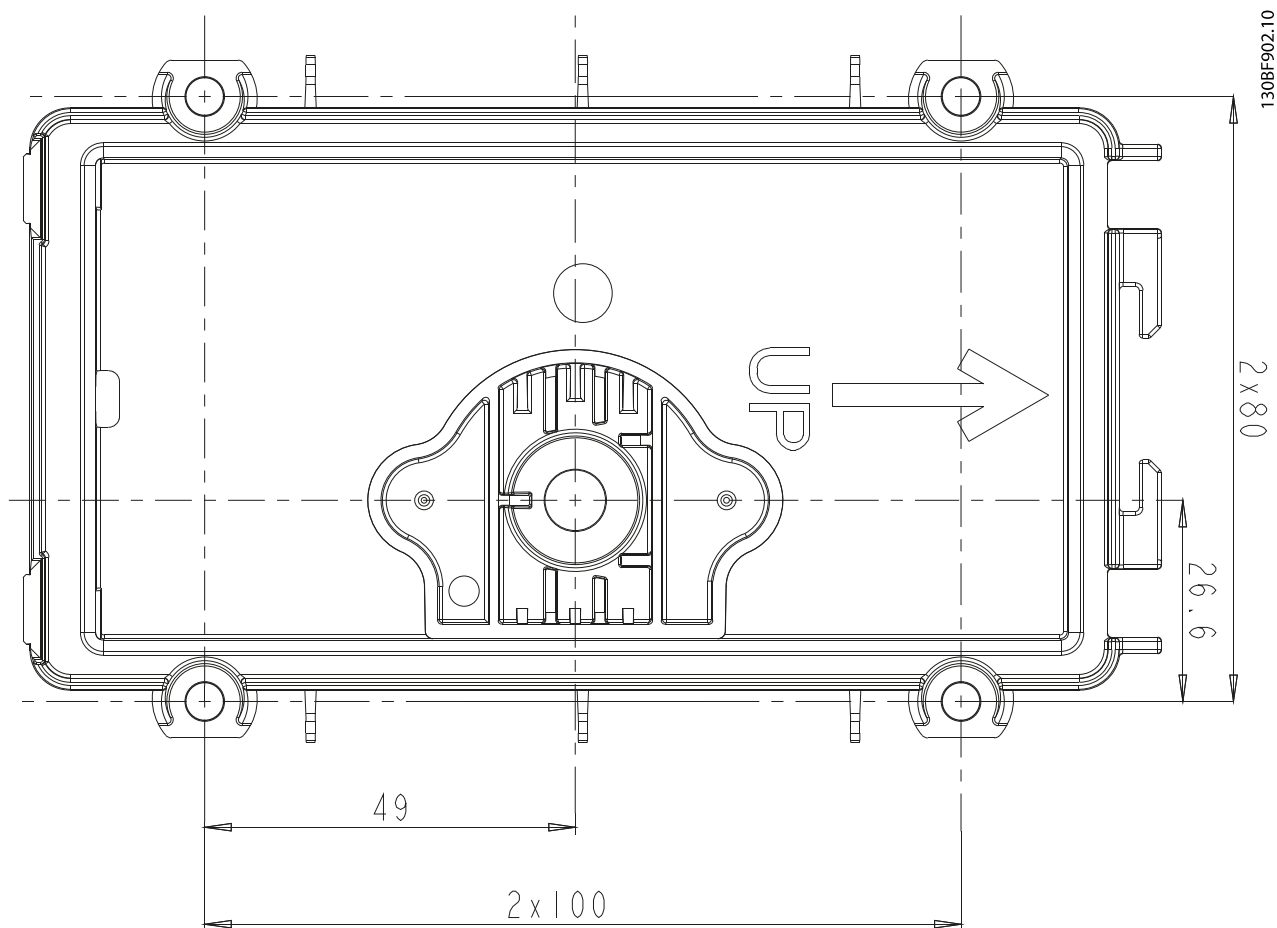

Illustration 1.15 Drilling Template, Scale of 1:1

.....  
Danfoss can accept no responsibility for possible errors in catalogues, brochures and other printed material. Danfoss reserves the right to alter its products without notice. This also applies to products already on order provided that such alterations can be made without subsequential changes being necessary in specifications already agreed. All trademarks in this material are property of the respective companies. Danfoss and the Danfoss logotype are trademarks of Danfoss A/S. All rights reserved.  
.....

Danfoss A/S  
Ulsnaes 1  
DK-6300 Graasten  
[vlt-drives.danfoss.com](http://vlt-drives.danfoss.com)

