

Installation Instructions

VLT® AutomationDrive FC 360 Decoupling Plate

1.1.1 Scope of Delivery

- Power decoupling plate
- I/O decoupling plate (0.37-2.2 kW only)
- Screws (m4x20)

Enclosure	Power range [kW]	Ordering number
J1	0.37-2.2	132B0258
J2/J3	3.0-7.5	132B0259
J4/J5	11-22	132B0260

Table 1.1 Ordering Numbers

1.1.2 Safety Instructions

Voltage [V]	Minimum waiting time [minutes]	
	4	15
380-480	0.37-7.5 kW	11-22 kW

Table 1.2 Discharge Time

1.1.3 Mounting I/O Decoupling Plate

(0.37-2.2 kW only)

Mount the I/O decoupling bracket on the power decoupling plate with 2 M4x10 screws (supplied).
Tightening torque: 1.0~1.2 Nm

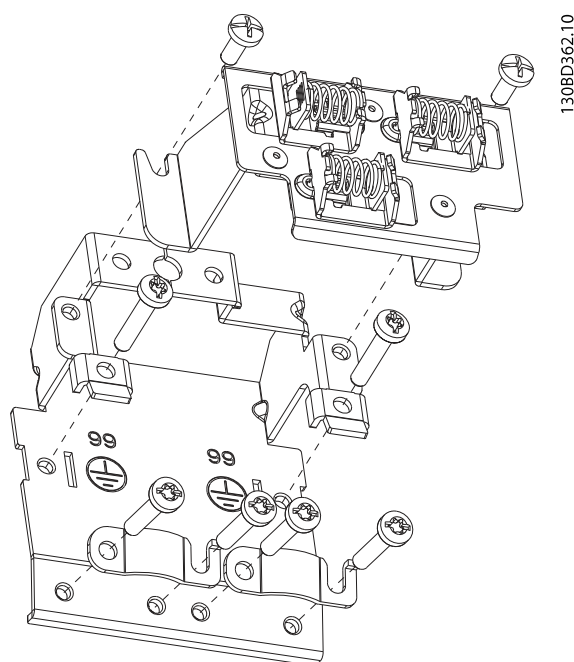
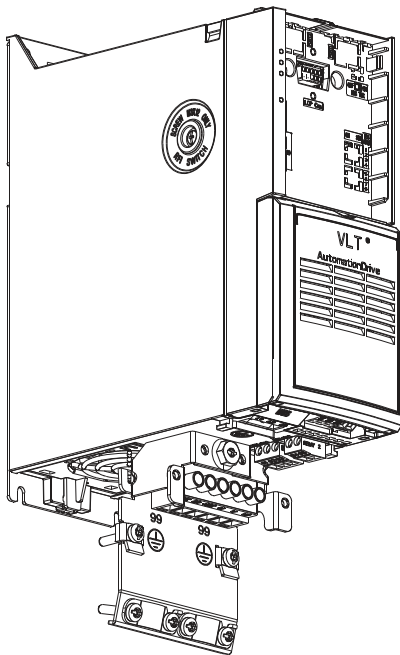

Illustration 1.1 Decoupling Plate

1.1.4 Mounting Power Decoupling Plate

0.37-7.5 kW

1. Remove the earth screw (M6x12) from the frequency converter.
2. Mount the power decoupling plate on the frequency converter and fasten it with the 2 supplied screws (M4x10).
Tightening torque: 1.0~1.2 Nm
3. Remount the earth screw (M6x12).
Tightening torque: 0.5~0.8 Nm



130BD361.10

Illustration 1.2 Frequency Converter without Decoupling Plate

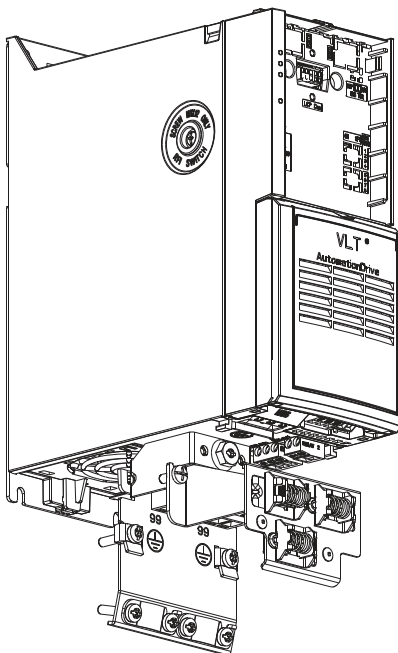

130BD363.10

Illustration 1.3 Frequency Converter with Decoupling Plate

11-22 kW

1. Remove the earth plate from the frequency converter (11 kW only).
2. Mount the power decoupling plate on the frequency converter and fasten it with the 2 supplied screws (M4x10).
Tightening torque: 1.0~1.2 Nm

3. Remount the earth screw (M6x12).
Tightening torque: 0.5~0.8 Nm

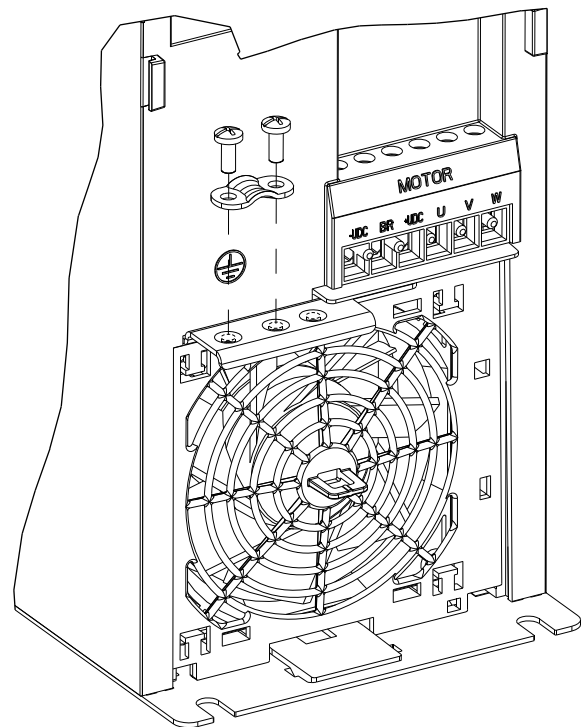

130BD444.10

Illustration 1.4 Demounting the Earth Plate

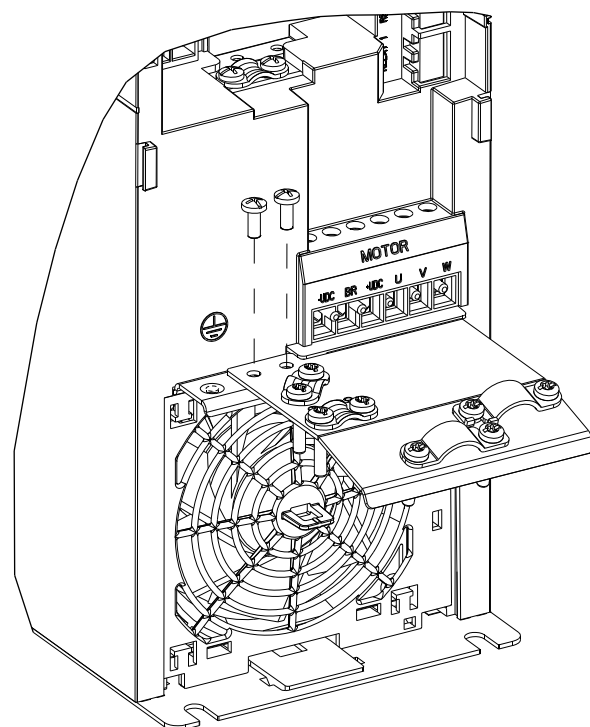

130BD445.10

Illustration 1.5 Mounting the Decoupling Plate

Danfoss can accept no responsibility for possible errors in catalogues, brochures and other printed material. Danfoss reserves the right to alter its products without notice. This also applies to products already on order provided that such alterations can be made without subsequential changes being necessary in specifications already agreed. All trademarks in this material are property of the respective companies. Danfoss and the Danfoss logotype are trademarks of Danfoss A/S. All rights reserved.

