

# Installation Instructions

## Decoupling Plate Kit

### VLT<sup>®</sup> AutomationDrive FC 360

These instructions provide information about replacement of the decoupling plate kit in the VLT<sup>®</sup> AutomationDrive FC 360.

Only Danfoss-authorized, qualified personnel is allowed to repair this equipment. The personnel must be familiar with the instructions and safety measures described in the *VLT<sup>®</sup> AutomationDrive FC 360 Service Manual*.

#### 1.1.1 Items Supplied

Items supplied depend on the ordering number and enclosure type of the frequency converter.

Ordering numbers	Items supplied
132B0258	<ul style="list-style-type: none"> <li>Power decoupling plate, J1</li> <li>I/O decoupling plate</li> <li>Screws (M4x10)</li> </ul>
132B0259	<ul style="list-style-type: none"> <li>Power decoupling plate, J2/J3</li> <li>Screws (M4x10)</li> </ul>
132B0260	<ul style="list-style-type: none"> <li>Power decoupling plate, J4/J5</li> <li>Screws (M4x10)</li> </ul>
132B0284	<ul style="list-style-type: none"> <li>Power decoupling plate, J6</li> <li>Shield plate for line-in and motor</li> <li>Screws (M4x12)</li> <li>Earth plates</li> </ul>
132B0285	<ul style="list-style-type: none"> <li>Power decoupling plate, J7</li> <li>Screws (M4x6)</li> <li>Earth plates</li> </ul>

Table 1.1 Ordering Numbers

#### 1.1.2 Tools Required

- Screwdrivers:
  - Flat-edged
  - T10
  - T20
  - T25
  - T30
- N8 socket wrench
- N10 socket wrench
- N5 Allen key

#### 1.1.3 Safety Instructions

### **⚠ WARNING**

#### DISCHARGE TIME

The frequency converter contains DC-link capacitors, which can remain charged even when the frequency converter is not powered. Failure to wait the specified time after power has been removed before performing service or repair work, could result in death or serious injury.

- Stop the motor.
- Disconnect AC mains, permanent magnet type motors, and remote DC-link power supplies, including battery back-ups, UPS, and DC-link connections to other frequency converters.
- Wait for the capacitors to discharge fully, before performing any service or repair work. The duration of waiting time is specified in *Table 1.2*.

Voltage [V]	Minimum waiting time (minutes)	
	4	15
380-480	0.37-7.5 kW	11-75 kW

High voltage may be present even when the warning LEDs are off!

Table 1.2 Discharge Time

### 1.1.4 Mounting I/O Decoupling Plate

#### For J1 Enclosure Type Only

Mount the I/O decoupling bracket on the power decoupling plate with 2 M4x10 screws (supplied).

Tightening torque: 1.0~1.2 Nm

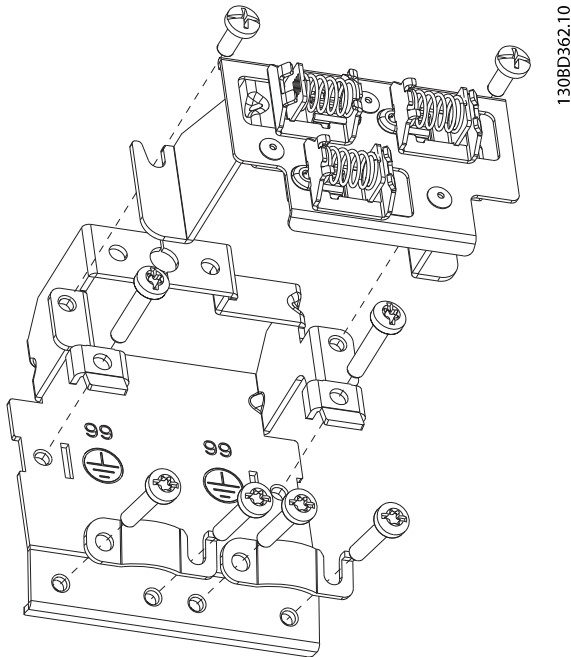

Illustration 1.1 I/O Decoupling Plate, J1

### 1.1.5 Mounting Power Decoupling Plate

#### For J1, J2 and J3 Enclosure Types

1. Remove the earth screw (M6x12) from the frequency converter.
2. Mount the power decoupling plate on the frequency converter and fasten it with the 2 supplied screws (M4x10).  
Tightening torque: 1.0~1.2 Nm
3. Remount the earth screw (M6x12).  
Tightening torque: 0.5~0.8 Nm

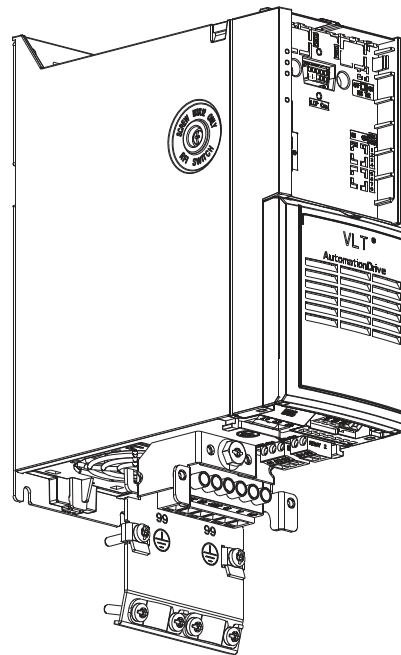

Illustration 1.2 Frequency Converter without Decoupling Plate, J1-J3

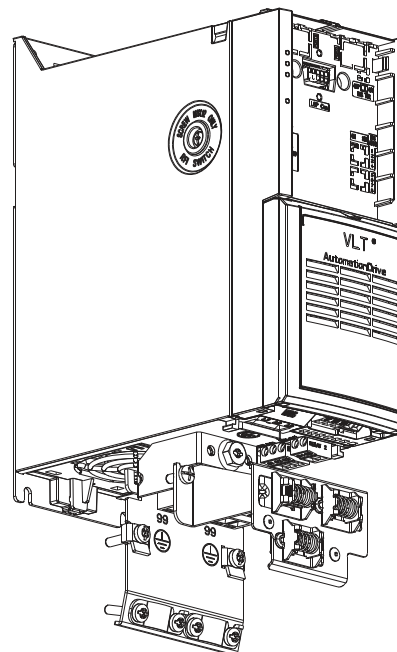

Illustration 1.3 Frequency Converter with Decoupling Plate, J1-J3

## For J4 and J5 Enclosure Types

1. Remove the earth plate from the frequency converter (J4 only).
2. Mount the power decoupling plate on the frequency converter and fasten it with the 2 supplied screws (M4x10).  
Tightening torque: 1.0~1.2 Nm
3. Remount the earth screw (M6x12).  
Tightening torque: 0.5~0.8 Nm

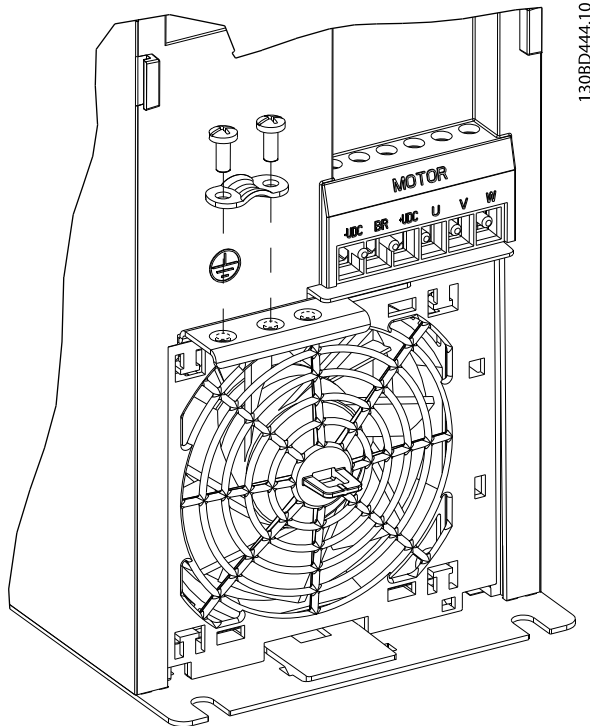

Illustration 1.4 Remove the Earth Plate, J4

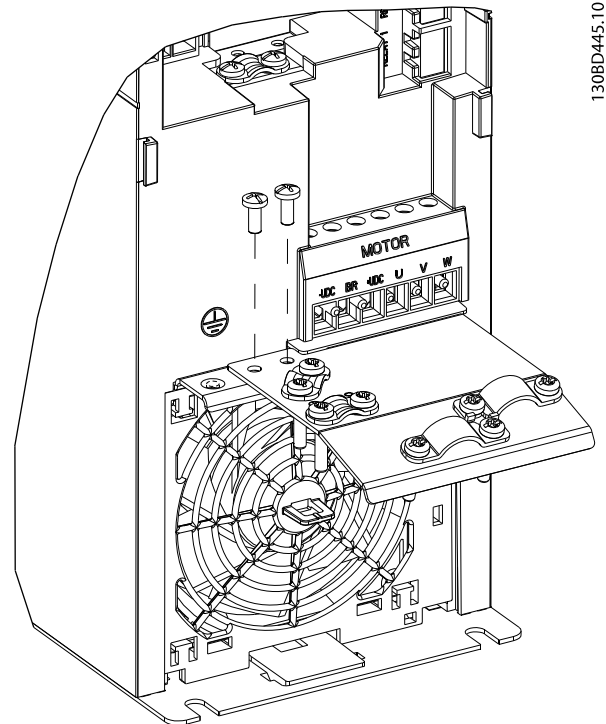

Illustration 1.5 Mount the Decoupling Plate, J4-J5

## For J6 Enclosure Type

1. Remove the right earth plate.
2. Fit the snaps of the power decoupling plate into the slots on the frequency converter and fasten the 2 M4x12 screws, as shown in *Illustration 1.6*.

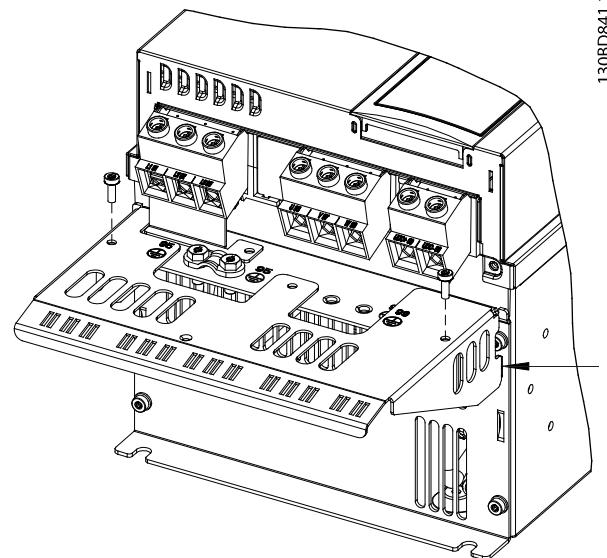

Illustration 1.6 Mount the Power Decoupling Plate, J6

3. Fasten the shield plate to the power decoupling plate with 3 screws, and mount the earth plate, as shown in *Illustration 1.7*.

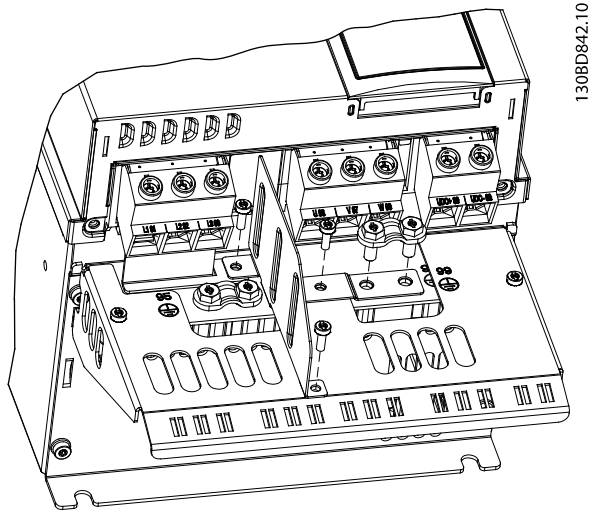

Illustration 1.7 Mount the Shield Plate

## For J7 Enclosure Type

1. Fit the snaps of the power decoupling plate into the slots and fasten the 2 M4x6 screws, as shown in *Illustration 1.8*.

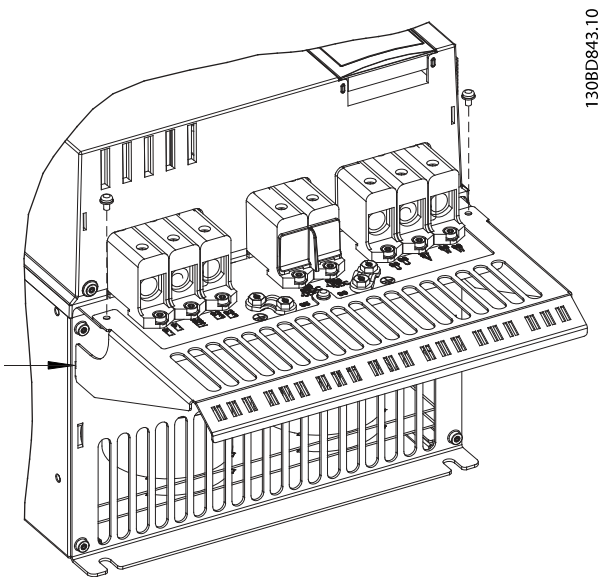

Illustration 1.8 Mount the Power Decoupling Plate, J7

Danfoss can accept no responsibility for possible errors in catalogues, brochures and other printed material. Danfoss reserves the right to alter its products without notice. This also applies to products already on order provided that such alterations can be made without subsequential changes being necessary in specifications already agreed. All trademarks in this material are property of the respective companies. Danfoss and the Danfoss logotype are trademarks of Danfoss A/S. All rights reserved.

