

Installation Instructions

PROFIBUS/PROFINET Decoupling Kit

VLT[®] AutomationDrive FC 360

PROFIBUS/PROFINET decoupling kit for mounting the control cassette with PROFIBUS and control cassette with PROFINET. Mount the control cassette on the frequency converter before mounting the PROFIBUS/PROFINET decoupling kit.

Items Supplied

For each control cassette with PROFIBUS or control cassette with PROFINET, 2 decoupling kits are supplied in the package. Install the correct kit based on the enclosure size of the frequency converter.

Code number	Items supplied
132B0274	PROFIBUS/PROFINET decoupling kit for enclosure sizes J1–J5, containing the following items: <ul style="list-style-type: none"> Decoupling plate. 2 M3x6 screws.
132B0286	PROFIBUS/PROFINET decoupling kit for enclosure sizes J6 and J7, containing the following items: <ul style="list-style-type: none"> Decoupling plate. 2 M3x6 screws.

Table 1.1 Items Supplied

Safety Instructions



DISCHARGE TIME

The frequency converter contains DC-link capacitors, which can remain charged even when the frequency converter is not powered. Failure to wait the specified time after power has been removed before performing service or repair work, could result in death or serious injury.

- Disconnect AC mains, permanent magnet type motors, and remote DC-link power supplies, including battery back-ups, UPS, and DC-link connections to other frequency converters.
- Wait for the capacitors to discharge fully, before performing any service or repair work. The duration of waiting time is specified in *Table 1.2*.

Voltage [V]	Minimum waiting time (minutes)	
	4	15
380–480	0.37–7.5 kW	11–75 kW
High voltage may be present even when the warning LEDs are off!		

Table 1.2 Discharge Time

Refer to the *quick guide* for detailed information about safe installation of the frequency converter.

Mounting

1. Place the decoupling plate on the control cassette that is mounted on the frequency converter, and fasten the plate using 2 screws (supplied). Tightening torque 0.7–1.0 Nm.

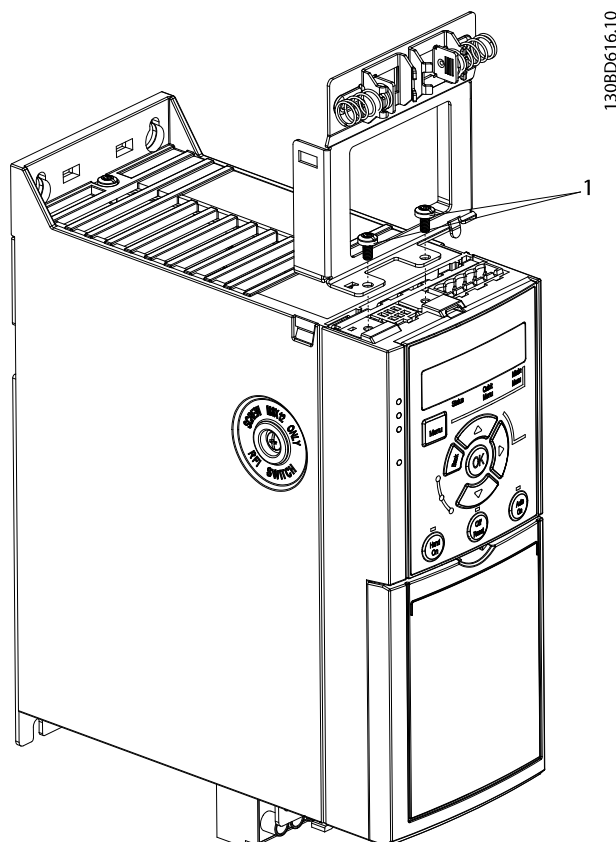

1	Screws
---	--------

Illustration 1.1 Fasten the Plate with Screws

2. 2a **PROFIBUS**

- a. Push PROFIBUS cables into the slots of the 5-pin connector, and tighten the screws. Tightening torque 0.3–0.6 Nm.
- b. Place the cables between the spring-loaded metal clamps, to establish contact and mechanical fixation between cable shielding and the clamps.
- c. Push the 5-pin connector into the control cassette, as shown in *Illustration 1.2*.

2b **PROFINET**

- a. Push the Ethernet cable connectors into the slots on the control cassette.
- b. Place Ethernet cables between the spring loaded metal clamps, as shown in *Illustration 1.3*, to establish mechanical fixation and electrical contact between the cable and ground.

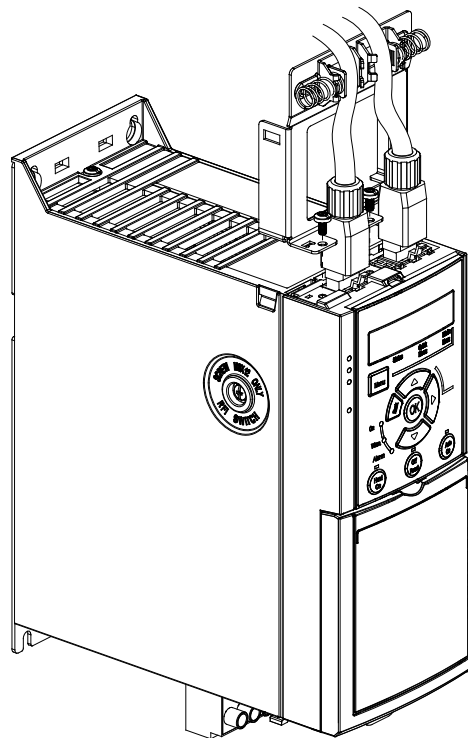

130BE308:10

Illustration 1.3 Place Ethernet Cables between Clamps

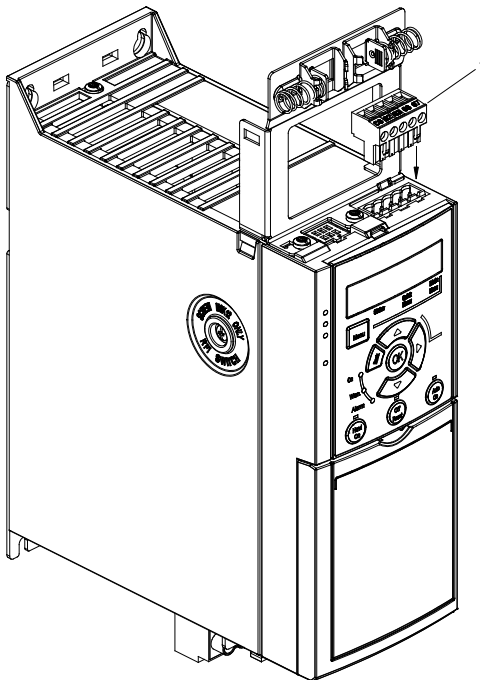

130BE317:10

1	5-pin connector for PROFIBUS
---	------------------------------

Illustration 1.2 Push the Connector into Place

.....
 Danfoss can accept no responsibility for possible errors in catalogues, brochures and other printed material. Danfoss reserves the right to alter its products without notice. This also applies to products already on order provided that such alterations can be made without subsequential changes being necessary in specifications already agreed. All trademarks in this material are property of the respective companies. Danfoss and the Danfoss logotype are trademarks of Danfoss A/S. All rights reserved.

Danfoss A/S
 Ulsnaes 1
 DK-6300 Graasten
 vlt-drives.danfoss.com

