

# Installation Instructions

## Fan Replacement

### VLT<sup>®</sup> Midi Drive FC 280

The instructions provide information about fan replacement in the VLT<sup>®</sup> Midi Drive FC 280.

Only Danfoss authorized, qualified personnel is allowed to repair this equipment. The personnel must be familiar with the instructions and safety measures described in the *VLT<sup>®</sup> Midi Drive FC 280 Service Guide*.

#### Items Supplied

Items supplied depend on ordered code number and enclosure type of the frequency converter.

#### Ordering Numbers

Enclosure	Power range [kW (hp)]	Ordering number
K1	0.37–2.2 (0.5–3.0)	132B0351
K2	3.0–5.5 (4.0–7.5)	132B0352
K3	7.5 (10)	132B0353
K4	11–15 (15–20)	132B0371
K5	18.5–22 (25–30)	132B0372

#### Tools Required

- Screwdrivers:
  - Flat-edged
  - T10

#### Tightening torques

- 0.5–0.7 Nm (4.4–6.2 in-lb)

#### Safety Instructions

### **⚠ WARNING**

#### DISCHARGE TIME

The frequency converter contains DC-link capacitors, which can remain charged even when the frequency converter is not powered. High voltage can be present even when the warning LED indicator lights are off. Failure to wait the specified time after power has been removed before performing service or repair work can result in death or serious injury.

- Stop the motor.
- Disconnect AC mains and remote DC-link supplies, including battery back-ups, UPS, and DC-link connections to other frequency converters.
- Disconnect or lock PM motor.
- Wait for the capacitors to discharge fully. The minimum waiting time is specified in *Table 1.1*.
- Before performing any service or repair work, use an appropriate voltage measuring device to make sure that the capacitors are fully discharged.

Voltage [V]	Power range [kW (hp)]	Minimum waiting time (minutes)
200–240	0.37–3.7 (0.5–5)	4
380–480	0.37–7.5 (0.5–10)	4
	11–22 (15–30)	15

Table 1.1 Discharge Time

## Installation

### Enclosure Sizes K1, K2, and K4

1. Grab the center handle on the fan and use a flat-edged screwdriver to release the retaining lever.

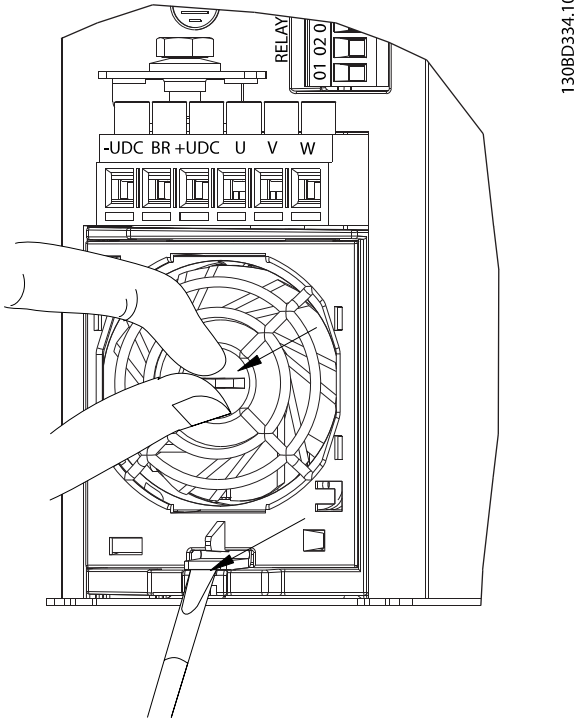

1308D334.10

Illustration 1.1 Removing Fan on Enclosure Sizes K1, K2, and K4

2. Unplug the fan cable.

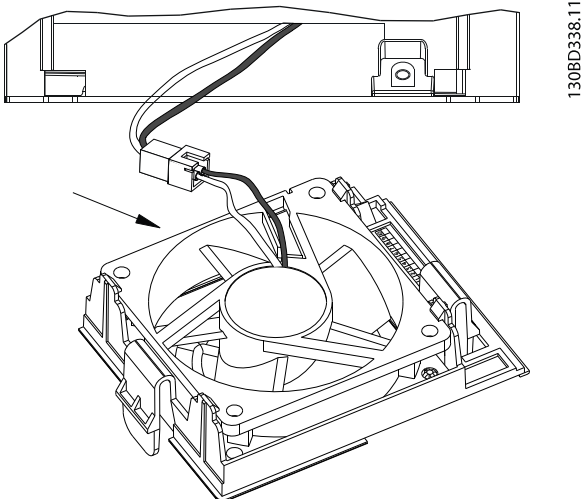

1308D338.11

Illustration 1.2 Fan Cable Plug. Plug Location Depends on Fan Type.

## NOTICE

For VLT® Midi Drive FC 280, the fan cable has 3 wires.

3. Connect the new fan cable and click the new fan into place.

### Enclosure Size K3

1. Remove the M3x6 screw in the bottom right corner.

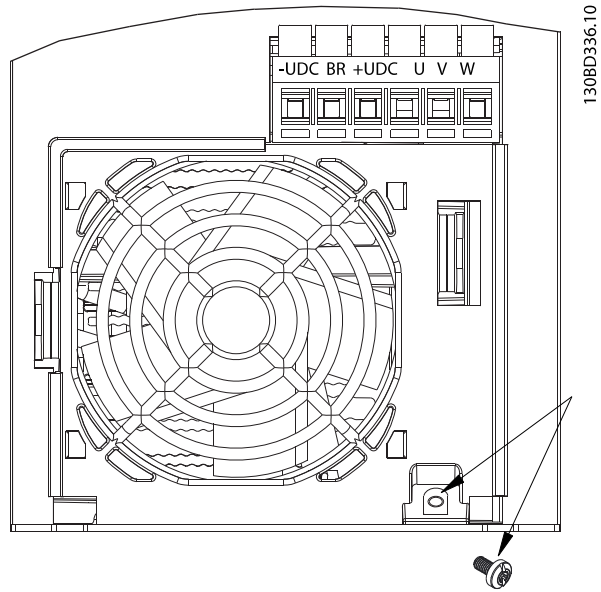

1308D336.10

Illustration 1.3 Removing Fan Screw on Enclosure Size K3

2. Press the levers on each side of the fan and pull the fan outwards.

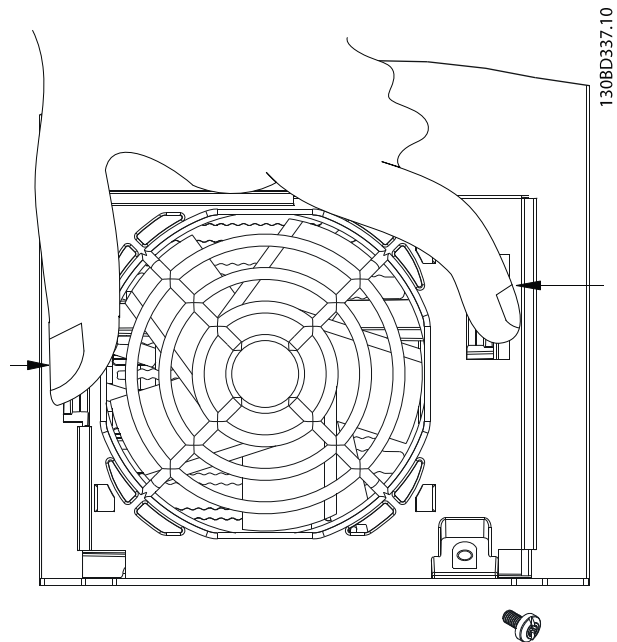

1308D337.10

Illustration 1.4 Pulling out Fan on Enclosure Size K3

3. Unplug the fan cable.

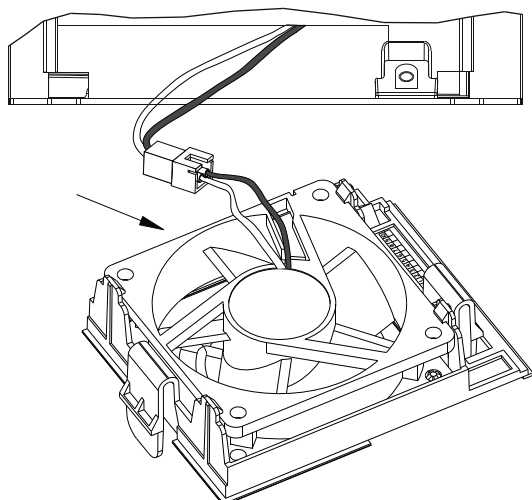

130BD338.11

Illustration 1.5 Fan Cable Plug. Plug Location Depends on Fan Type.

### **NOTICE**

For VLT® Midi Drive FC 280, the fan cable has 3 wires.

4. Install the new fan in reverse order.

### Enclosure Size K5

1. Remove M4x50 screws in the bottom right and upper left corners.

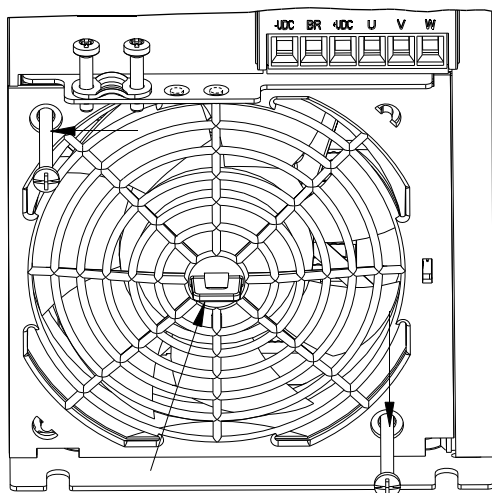

130BD395.10

Illustration 1.6 Removing Fan Screws on Enclosure Size K5

2. Grab the center handle and pull the fan outwards.
3. Unplug the fan cable.

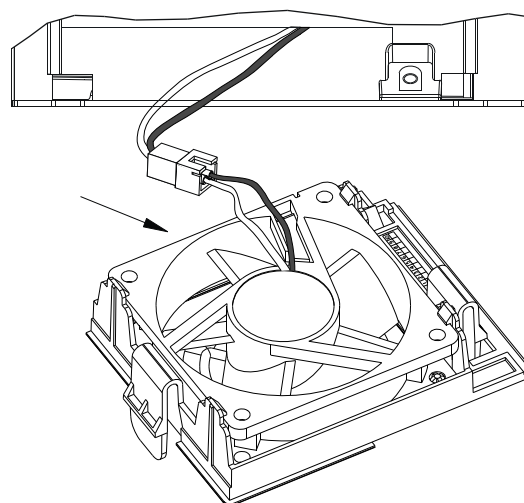

130BD338.11

Illustration 1.7 Fan Cable Plug. Plug Location Depends on Fan Type.

### **NOTICE**

For VLT® Midi Drive FC 280, the fan cable has 3 wires.

4. Install the new fan in reverse order.

.....  
Danfoss can accept no responsibility for possible errors in catalogues, brochures and other printed material. Danfoss reserves the right to alter its products without notice. This also applies to products already on order provided that such alterations can be made without subsequential changes being necessary in specifications already agreed. All trademarks in this material are property of the respective companies. Danfoss and the Danfoss logotype are trademarks of Danfoss A/S. All rights reserved.  
.....

Danfoss A/S  
Ulsnaes 1  
DK-6300 Graasten  
vlt-drives.danfoss.com

