



**TRANE®**

# MCB 105 - Relay I/O Option Module Operating Instructions

---

## TR200



**BAS-SVX29A-EN**

---

December 2008

**BAS-SVX29A-EN**

## Warnings, Cautions and Notices

Note that warnings, cautions and notices appear at appropriate intervals throughout this manual. Warnings are provide to alert installing contractors to potential hazards that could result in personal injury or death. Cautions are designed to alert personnel to hazardous situations that could result in personal injury, while notices indicate a situation that could result in equipment or property-damage-only accidents.

Your personal safety and the proper operation of this machine depend upon the strict observance of these precautions.

Warnings, Cautions and Notices appear at appropriate sections throughout this literature. Read these carefully.

### **WARNING**

Indicates a potentially hazardous situation which, if not avoided, could result in death or serious injury.

### **CAUTION**

Indicates a potentially hazardous situation which, if not avoided, could result in minor or moderate injury. It could also be used to alert against unsafe practices.

### **NOTICE**

Indicates a situation that could result in equipment or property-damage only accidents.

#### Note

Indicates something important to be noted by the reader.

★	Indicates default setting
---	---------------------------

## TR200 MCB 105 Relay I/O Option Module

The MCB 105 option includes 3 pieces of change over contacts and can be fitted into option slot B.

### Electrical Data:

Max. terminal load (AC)	240 V AC 2A
Max. terminal load (DC)	24 V DC 1A
Min. terminal load (DC)	5 V 10 mA
Max. switching rate at rated load/min. load	6 min <sup>-1</sup> /20 sec <sup>-1</sup>

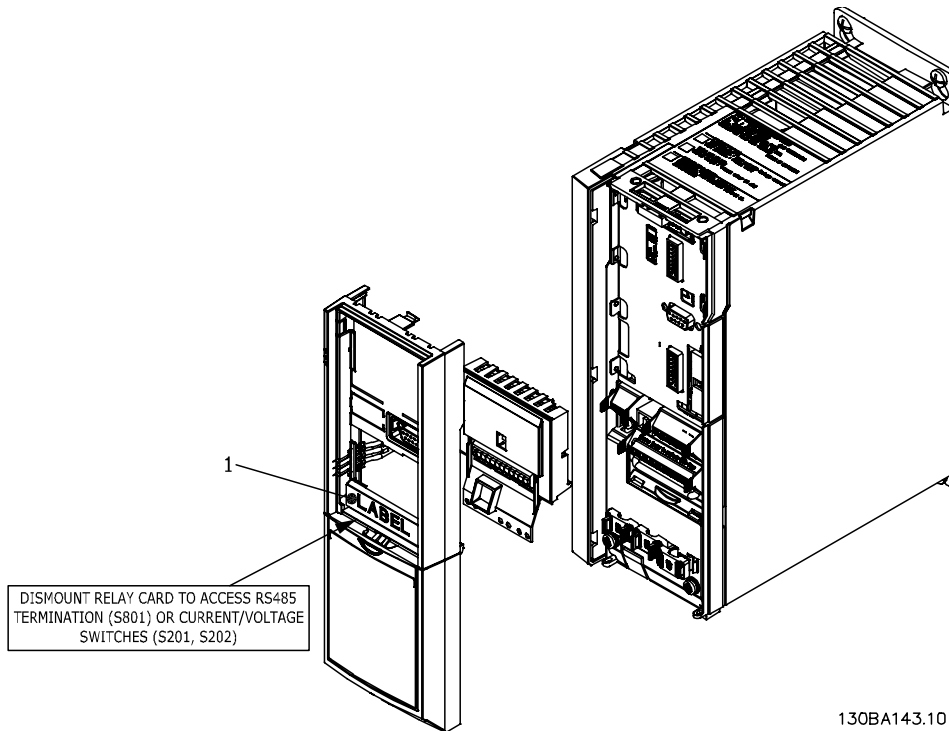

### Note:

#### Warning Dual Supply

- The label **MUST** be placed on the keypad frame as shown (UL approved).
- The power to the frequency converter must be disconnected.
- The power to the livepart connections on relay terminals must be disconnected.
- Remove the keypad, the terminal cover and the cradle from the frequency converter.
- Fit the MCB 105 option in slot B.
- Connect the control cables and relieve the cables by the enclosed cable strips.
- Various systems must not be mixed.
- Fit the extended cradle and terminal cover.
- Replace the keypad.
- Connect power to the frequency converter.
- Select the relay functions in par. 5-40 [6-8], par. 5-41 [6-8] and par. 5-42 [6-8].

**Array [6] is relay 7, array [7] is relay 8 and array [8] is relay 9.**

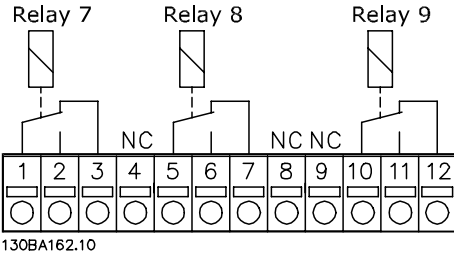

130BA176.10

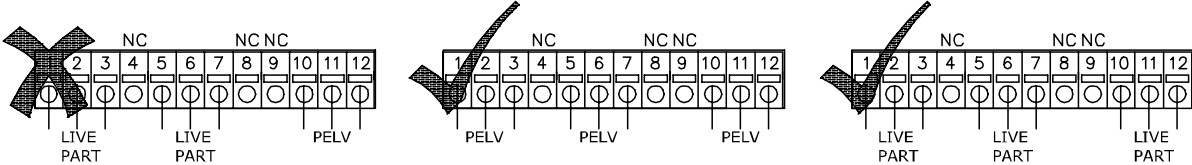
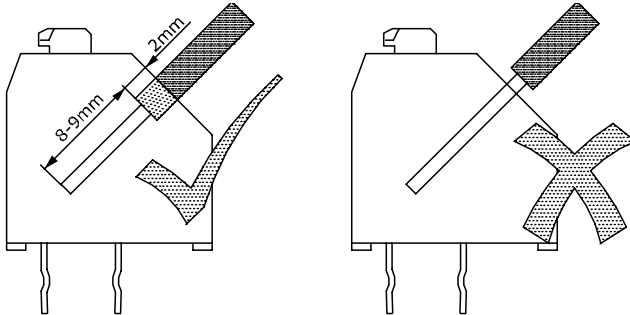

Illustration 1. 1: Correct relay wiring

**Do not combine liveparts and PELV systems.**



130BA177.10

Illustration 1. 2: Correct wire inserting.



**[www.trane.com](http://www.trane.com)**

*For more information, contact your local Trane office or e-mail us at [comfort@trane.com](mailto:comfort@trane.com)*

---

Literature Order Number                      BAS-SVX29A-EN

---

Date    December 2008

---

Supersedes

---

Trane has a policy of continuous product and product data improvement and reserves the right to change design and specifications without notice.

