

# Installation Instructions

## TR150 Remote Mounting Kit

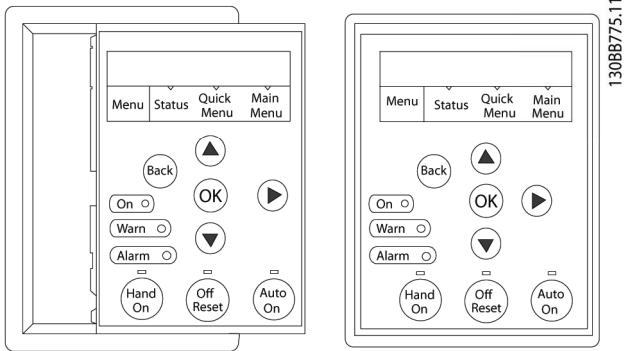

**Step 1**  
Fit gasket on keypad.



130BB775.11

Illustration 1.1 Fit Gasket

**Step 2**  
Place keypad on panel, see dimensions of hole on *Illustration 1.2*.

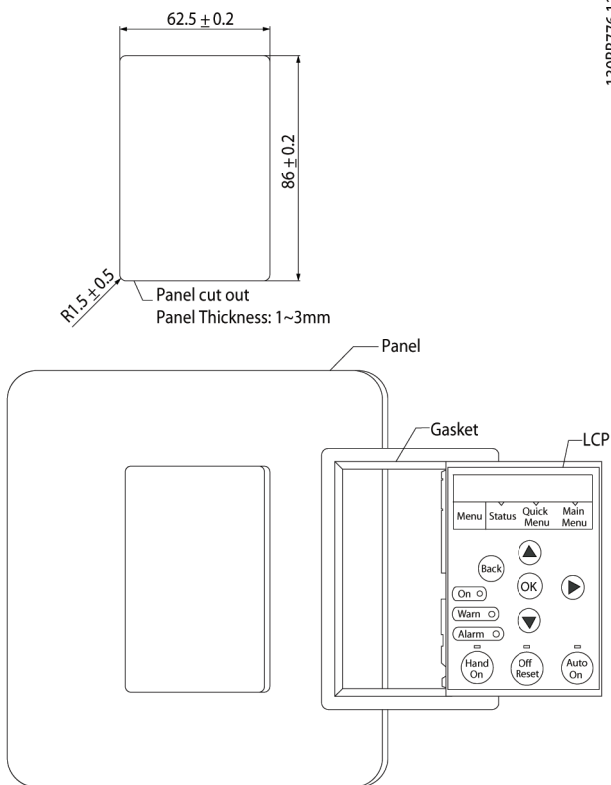

130BB776.11

Illustration 1.2 Place Keypad on Panel

**Step 3**  
Place bracket on back of the keypad, then slide down. Tighten screws and connect cable female side to keypad

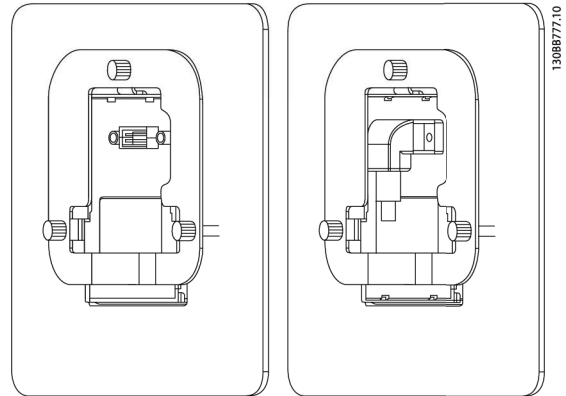

130BB777.10

Illustration 1.3 Place Bracket on keypad

### NOTE

Use the provided thread cutting screws to fasten connector to keypad.  
Tightening torque: 1.3 Nm

**Step 4**  
Connect cable to frequency converter

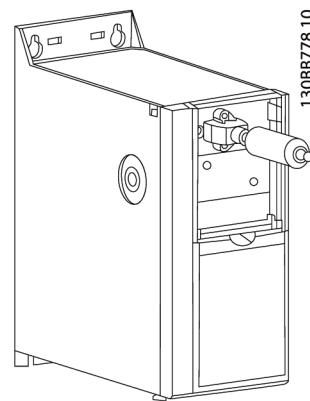

130BB778.10

Illustration 1.4 Connect Cable

### NOTE

Use the provided thread cutting screws to fasten connector to the frequency converter.  
Tightening torque: 1.3 Nm



[www.trane.com](http://www.trane.com)

For more information, contact your local Trane office or e-mail us at [comfort@trane.com](mailto:comfort@trane.com)

---

Literature Order Number	BAS-SVX61A-EN
Date	April 2013
Supersedes	

---

Trane has a policy of continuous product and product data improvement and reserves the right to change design and specifications without notice.

