

Installation Instructions

Remote Mounting of LCP

VLT[®] HVAC Basic Drive FC 101

Items Supplied

The remote mounting kit (ordering number: 132B0206) includes:

- Gasket.
- Screws (3 pieces).
- Mounting plate bracket.

Additional Items Required

- Local control panel (LCP), ordering number 132B0200.
- LCP 31 to RJ 45 converter kit, ordering number 132B0203.

Safety Instructions

For important information about safety precautions for installation, refer to *VLT[®] HVAC Basic Drive FC 101 Quick Guide*.

⚠ WARNING

DISCHARGE TIME

The frequency converter contains DC-link capacitors, which can remain charged even when the frequency converter is not powered. Failure to wait the specified time after power has been removed before performing service or repair work, could result in death or serious injury.

- Stop the motor.
- Disconnect AC mains, permanent magnet type motors, and remote DC-link power supplies, including battery back-ups, UPS, and DC-link connections to other frequency converters.
- Wait for the capacitors to discharge fully, before performing any service or repair work. The duration of waiting time is specified in *Table 1.1*.

Voltage [V]	Power range [kW (hp)]	Minimum waiting time (minutes)
3x200	0.25–3.7 (0.34–5)	4
3x200	5.5–11 (7.5–15)	15
3x400	0.37–7.5 (0.5–10)	4
3x400	11–90 (15–125)	15
3x600	2.2–7.5 (3–10)	4
3x600	11–90 (15–125)	15

Table 1.1 Discharge Time for FC 101

Mechanical Installation

1. Fit gasket on LCP, see *Illustration 1.1*.

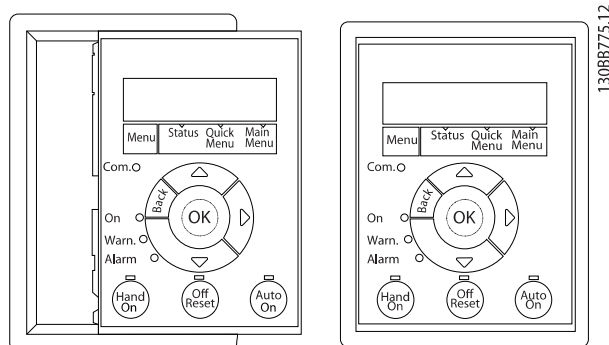
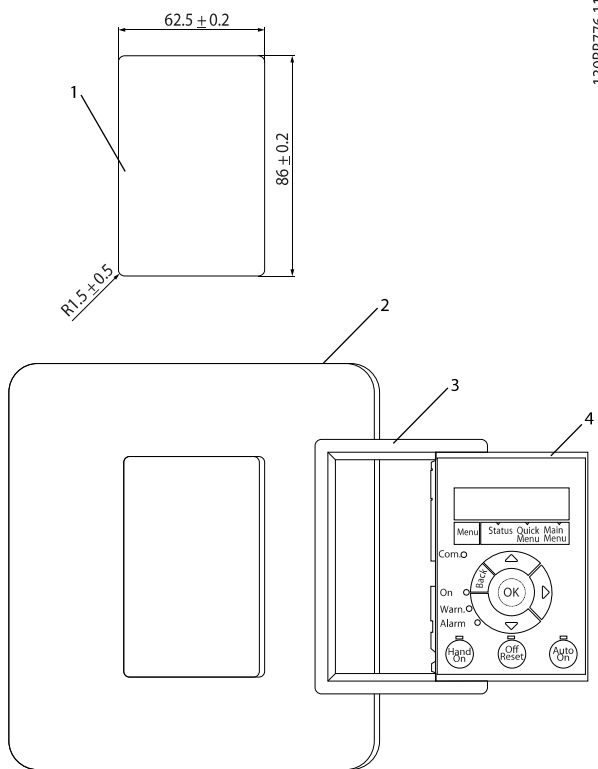

Illustration 1.1 Fit Gasket on LCP

2. Cut out the panel, with the dimensions shown in *Illustration 1.2*.
3. Position LCP with gasket onto the panel, as shown in *Illustration 1.2*.



13088776.11

1	Panel cut out. Panel thickness 1–3 mm (0.04–0.12 in)
2	Panel
3	Gasket
4	LCP

Illustration 1.2 Mounting of LCP on Panel

- Position bracket on the back of the LCP, then slide down. See *Illustration 1.3*.
- Fasten bracket to the LCP using the thread cutting screws supplied. Tightening torque is 1.3 Nm (11.5 in-lb).

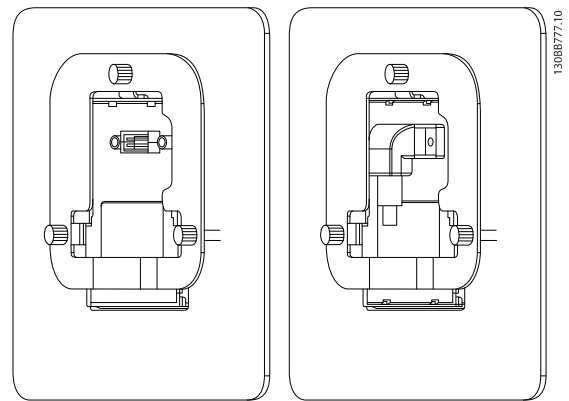

13088777.10

Illustration 1.3 Position Bracket and Slide Down

Electrical Installation

- Connect the LCP cable to the frequency converter, as shown in *Illustration 1.4*.
- Fasten the connector to the frequency converter using the thread cutting screws supplied. Tightening torque is 1.3 Nm (11.5 in-lb).

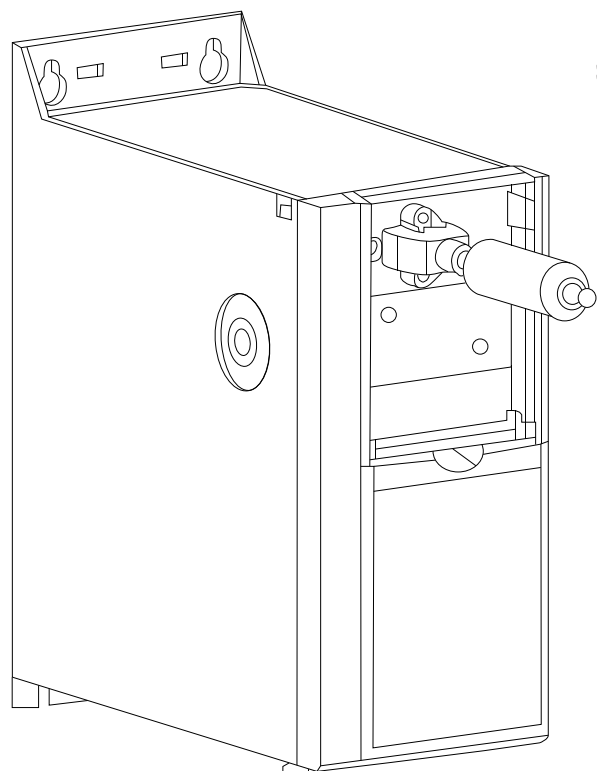

13088778.10

Illustration 1.4 Connection at Frequency Converter

Danfoss can accept no responsibility for possible errors in catalogues, brochures and other printed material. Danfoss reserves the right to alter its products without notice. This also applies to products already on order provided that such alterations can be made without subsequential changes being necessary in specifications already agreed. All trademarks in this material are property of the respective companies. Danfoss and the Danfoss logotype are trademarks of Danfoss A/S. All rights reserved.

