

GE Consumer & Industrial
Electrical Distribution

AF-650 GP™ & AF-600 FP™ OPCGPIO General Purpose I/O Option Module



a product of
ecomagination





1.1.1 Introduction

This instruction describes the General Purpose I/O option OPCGPIO for use in the AF-600 FP and AF-650 GP series, expanding the number of input/output in the adjustable frequency drive.

The OPCGPIO option includes 3 digital inputs, 2 analog inputs, 2 digital outputs and 1 analog output.

1.1.2 Product Number: OPCGPIO

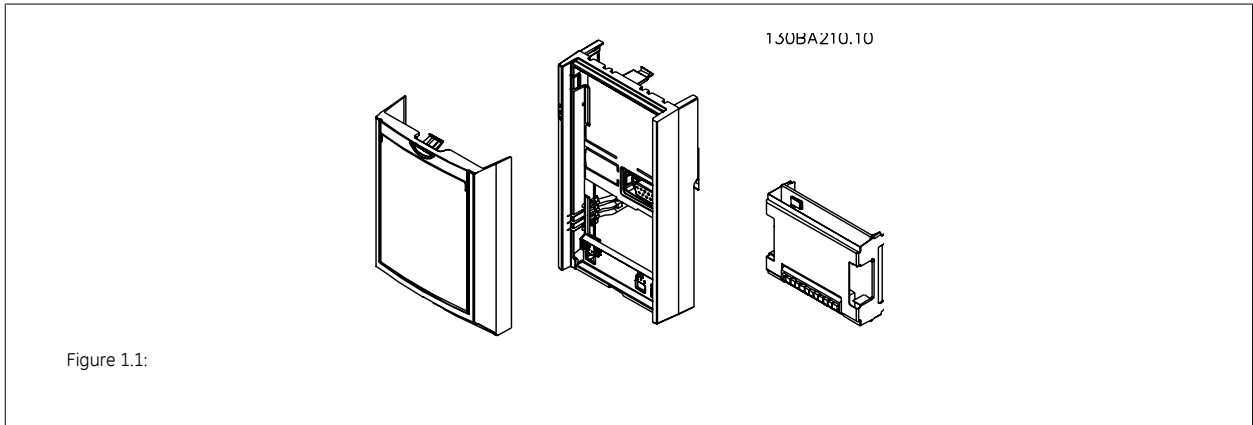



1.2.1 Galvanic Isolation in the OPCGPIO

1

Digital/analog inputs are galvanically isolated from other inputs/outputs on the OPCGPIO and in the control card of the adjustable frequency drive. Digital/analog outputs in the OPCGPIO are galvanically isolated from other inputs/outputs on the OPCGPIO, but not from these on the control card of the drive.

If digital inputs 7, 8 or 9 are to be switched using the internal 24 V power supply (terminal 9), the connection between terminal 1 and 5 illustrated in the drawing has to be established.

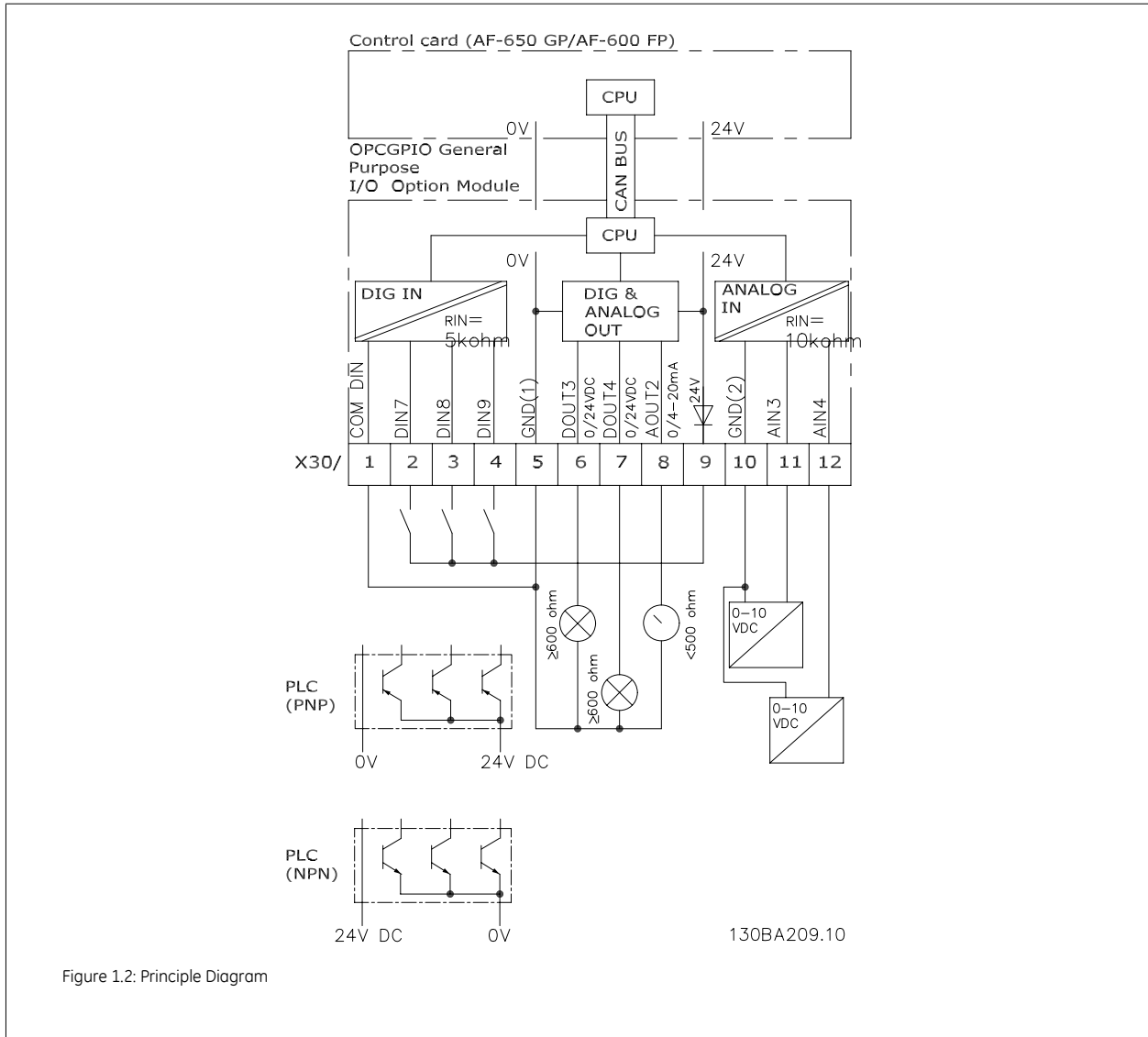

Figure 1.2: Principle Diagram



1.2.2 Digital inputs - Terminal X30/1-4

Parameters for set-up: E-53, E-54 and E-55				
Number of digital inputs	Voltage level	Voltage levels	Tolerance	Max. Input impedance
3	0-24 V DC	PNP type: Common = 0 V Logic "0": Input < 5 V DC Logic "0": Input > 10 V DC NPN type: Common = 24 V Logic "0": Input > 19 V DC Logic "0": Input < 14 V DC	± 28 V continuous ± 37 V in minimum 10 sec.	Approx. 5 k ohm

1

1.2.3 Analog voltage inputs - Terminal X30/10-12

Parameters for set-up: AN-3#, AN-4# and DR-76				
Number of analog voltage inputs	Standardized input signal	Tolerance	Resolution	Max. Input impedance
2	0-10 V DC	± 20 V continuously	10 bits	Approximately 5 K ohm

1.2.4 Digital outputs - Terminal X30/5-7

Parameters for set-up: E-56 and E-57			
Number of digital outputs	Output level	Tolerance	Max. impedance
2	0 or 24 V DC	± 4 V	≥ 600 ohm

1.2.5 Analog outputs - Terminal X30/5-8

Parameters for set-up: AN-6# and DR-77			
Number of analog outputs	Output signal level	Tolerance	Max. impedance
1	0/4-20 mA	± 0.1 mA	< 500 ohm



1

1.3.1 Mounting Option Modules in Slot B

The power to the adjustable frequency drive must be disconnected.

For Unit Sizes 12, 13 and 23:

- Remove the Keypad, the terminal cover, and the Keypad frame from the adjustable frequency drive.
- Fit the OPCGPIO option card into slot B.
- Connect the control cables and fasten the cables with the enclosed cable strips.
Remove the knock-out in the extended Keypad frame delivered in the option set so that the option will fit under the extended Keypad frame.
- Fit the extended Keypad frame and terminal cover.
- Fit the Keypad or blind cover in the extended Keypad frame.
- Connect power to the adjustable frequency drive.
- Set up the input/output functions in the corresponding parameters, as mentioned in this document.

For Unit Sizes 15, 21, 22, 24, 31, 32, 33, 34, 4X, 5X and 6X:

- Remove the Keypad and the Keypad cradle
- Fit the OPCGPIO option card into slot B
- Connect the control cables and relieve the cable by the enclosed cable strips.
- Fit the cradle.
- Fit the Keypad

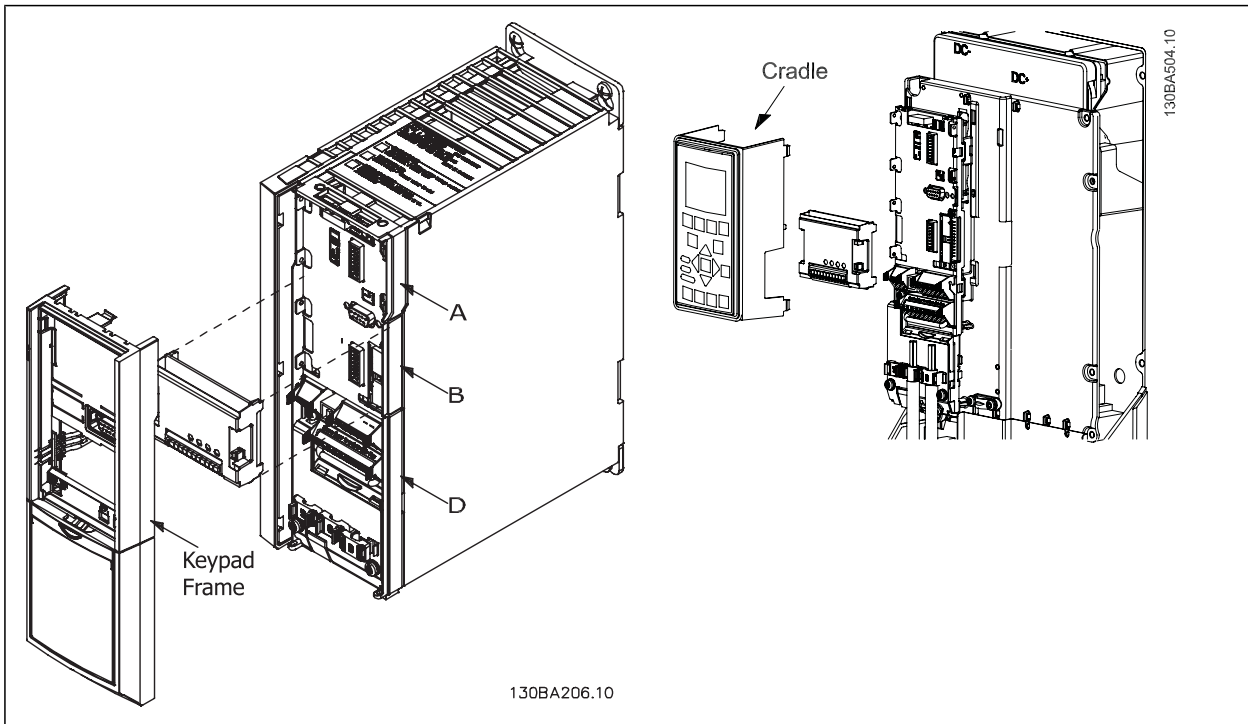

Unit Sizes 12, 13 and 23

Unit Sizes 15, 21, 22, 24, 31, 32, 33, 34, 4X, 5X and 6X



1.3.2 Mounting Guidelines - Step By Step

These step-by-step instructions describe how to mount the control cables:

- The power to the adjustable frequency drive must be disconnected.
- Remove the Keypad, the terminal cover, and the Keypad frame from the adjustable frequency drive.
- Fit the OPCGPIO option card into slot B.
- Connect the control cables and fasten the cables with the enclosed cable strips.
- Remove the knock-out in the extended Keypad frame, so that the option will fit under the extended Keypad frame.
- Fit the extended Keypad frame and terminal cover.
- Fit the Keypad or blind cover in the extended Keypad frame.
- Connect power to the adjustable frequency drive.
- Set up the input/output functions in the corresponding parameters, as mentioned in the *Programming Guide*.

1.3.3 How To Mount Cables

The graphic below illustrates how to mount the cables.

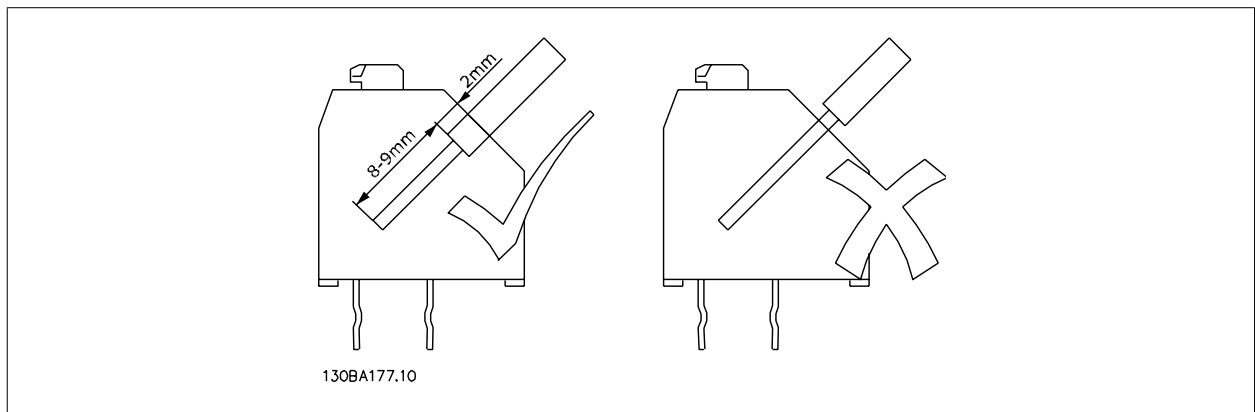

The instructions do not purport to cover all details or variations in equipment nor to provide for every possible contingency to be met in connection with installation, operation or maintenance. Should further information be desired or should particular problems arise which are not covered sufficiently for the purchaser's purposes, the matter should be referred to the GE company.

AF-650 GP and AF-600 FP are trademarks of the General Electric Company.

GE Consumer & Industrial
41 Woodford Avenue
Plainville, CT 06062

www.geelectrical.com/drives



imagination at work

130R0140



eDET-632a