

Installation Instructions

NEMA-3R for Non-Rittal Enclosure

D3h-D4h (FC Series FC 102, FC 202, and FC 302)

1.1 Description

The NEMA-3R kit is designed for a VLT® HVAC Drive FC 102, VLT® AQUA Drive FC 202, and VLT® AutomationDrive FC 302 D3h or D4h-size frequency converters that utilises the back-channel cooling (in-back/out-back) and is mounted in a non-Rittal enclosure. In addition to directing air in from and out of the back of the frequency converter, the NEMA-3R adds covers to the rear vents of the unit and provides a degree of protection against weather and hosed water. Refer to *Illustration 1.1*.

NOTICE

The current rating is derated by 3% when adding the NEMA-3R kit.

The kit contains the following parts:

Base duct assembly

- Duct enclosure (1)
- Gasket, left side enclosure (1)
- Gasket, right side enclosure (1)
- Gasket, top of enclosure (1)
- Gasket, back of enclosure(1)
- Gasket, base of enclosure (1)
- Grill (1)
- Gasket, grill (1)
- Cover, base of duct enclosure (1)
- Cover, back of duct enclosure (1)
- Nuts, M5 (21)
- Gasket, slot (1)
- Gasket, base cover of frequency converter (1)
- Cover, base of frequency converter (1)
- Screws, M5x12 (21) D3h or (24) D4h

Top plate assembly

- Top cover (1)
- Gasket, top cover (1)
- Gasket, cut out (1)
- Screws, M5x12 (11)

Enclosure mounting assembly

- Base mounting plate, 38 mm [1.5 in.] (2)
- Gasket, base mounting plate (2)
- Gasket, frequency converter exhaust vent (1)
- Screws, M5x12 (11)

Duct cover assemblies

- Cover, exhaust duct (1)
- Gasket, exhaust duct cover (1)
- Gasket, strip (1)
- Plate, exhaust cover (1)
- Cover, intake duct (1)
- Gasket, intake duct cover (1)
- Plate, intake cover (1)
- Screws, M5x12 (12)
- Screws, M5x18 (9) D3h or (10) D4h

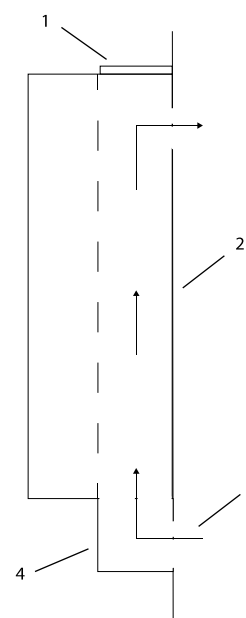

130BX518.10

1	Top plate assembly
2	Back panel of enclosure
3	Back-channel airflow
4	Base duct assembly

Illustration 1.1 Direction of Airflow with the Kit Installed

1.2 Kit Part Numbers

Part number	Kit description
176F3521	D3h, fabricated steel for a non-Rittal enclosure
176F3526	D4h, fabricated steel for a non-Rittal enclosure

Table 1.1 Part Numbers for all the D3h-D4h NEMA-3R Kits for Non-Rittal Enclosures

1.3 Preparing for Installation

⚠WARNING

DISCHARGE TIME

The frequency converter contains DC-link capacitors, which can remain charged even when the frequency converter is not powered. Failure to wait the specified time after power has been removed before performing service or repair work, could result in death or serious injury.

- Stop the motor.
- Disconnect the AC mains, permanent magnet type motors, and remote DC-link power supplies, including battery back-ups, UPS, and DC-link connections to other frequency converters.
- Wait for the capacitors to discharge fully, before performing any service or repair work. The duration of waiting time is specified in *Table 1.2*.
- Remove the frequency converter from the wall or panel.

Voltage [V]	Power range [kW]	Minimum waiting time (min)
3x400	90–250	20
3x400	110–315	20
3x500	110–315	20
3x500	132–355	20
3x525	75–250	20
3x525	90–315	20
3x690	90–250	20
3x690	110–315	20

Table 1.2 Discharge Time

1.4 Installation

This kit contains gaskets to ensure a proper seal between metal parts. Before adhering a gasket to a part, check that the part matches the gasket and that no holes are covered. Remove paper backing and place the sticky side on the part.

1.4.1 Assembling the Duct Enclosure

1. Place the left and right side gaskets (3, 6) against the side of the duct enclosure (7). Make sure the holes in the enclosure and gaskets line up. Refer to *Illustration 1.2*.
2. Place the grill (5) on top of the gaskets. The threaded studs in the grill go through the middle holes in the gasket and into the enclosure. Secure the grill to the enclosure using one nut on each stud. Torque to 2.3 N-m [20 in-lb].
3. Place the gasket (4) on top of the grill.
4. Place the gasket (8) and then the cover (10) on the enclosure base. Secure with 12 (D3h) or 14 (D4h) M5 nuts and torque to 2.3 N-m [20 in-lb].
5. Place the gasket (1) on the back side of the enclosure. Make sure the holes in the enclosure and gasket line up.
6. Place the gasket (2) on top of the duct enclosure.

NOTICE

The back cover (11) is left off until the duct assembly is attached to the frequency converter. The opening is necessary to secure the duct assembly to the frequency converter.

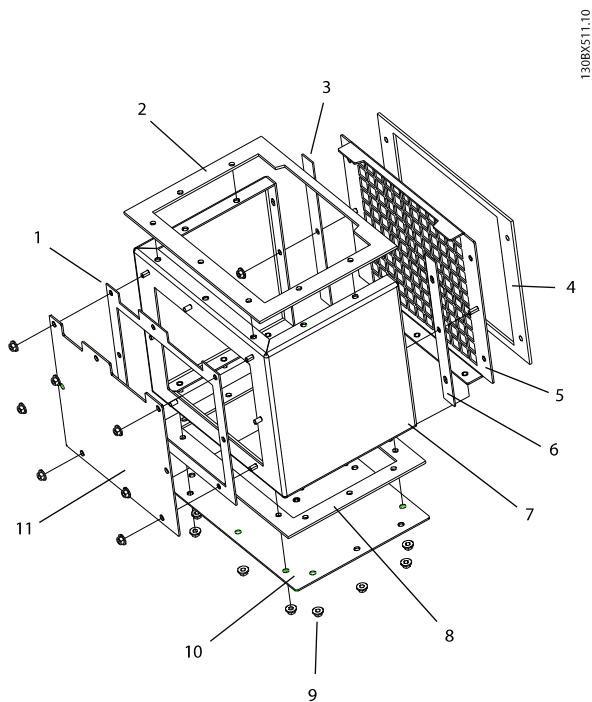

130BX5T1.10

1	Gasket, back of enclosure
2	Gasket, top of enclosure
3	Gasket, left side of enclosure
4	Gasket, grill
5	Grill
6	Gasket, right side of enclosure
7	Duct enclosure
8	Gasket, base of enclosure
9	M5 nuts
10	Cover, base of duct enclosure
11	Cover, back of duct enclosure

Illustration 1.2 Assembling the Bottom Duct

- Reinstall the gland plate (5) to the base cover using 6 M5x12 screws. Torque to 2.3 N-m [20 in-lb].
- Set aside the duct assembly. It is attached to the unit after the frequency converter is mounted to the enclosure.

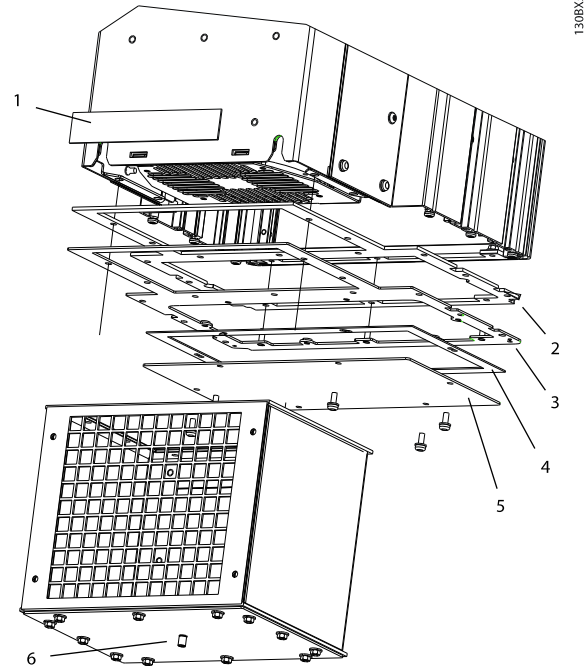

130BX5T1.2.10

1	Gasket, slot
2	Gasket, base cover of frequency converter
3	Cover, base of frequency converter
4	Gasket, gland plate
5	Gland plate
6	Drain hose fitting

Illustration 1.3 Installing Duct Assembly, Back View of Duct Shown

1.4.2 Installing the Duct Assembly

- Place the gasket (1) over the 2 slots at the bottom back of the frequency converter. Refer to *Illustration 1.3*.
- Remove the gland plate (5) from frequency converter base by removing 6 M5x12 screws.
- Remove base cover and gasket from frequency converter by removing 6 M4.8x19 screws and 3 M5x12 screws. Retain the screws, but discard old base cover and gasket.
- Place the gasket (2) onto the new base cover (3). Then place the new base cover onto the base of the frequency converter. Secure the new base cover using the screws from old base cover. Torque to 2.3 N-m [20 in-lb].

1.4.3 Installing the Top Plate Assembly

1. Place the gasket (3) over the grill opening on the top of the unit. Refer to *Illustration 1.4*.
2. Place the top cover (1) over the gasket. Secure it using the 11 screws included in the kit. Torque to 2.3 N-m [20 in-lb].

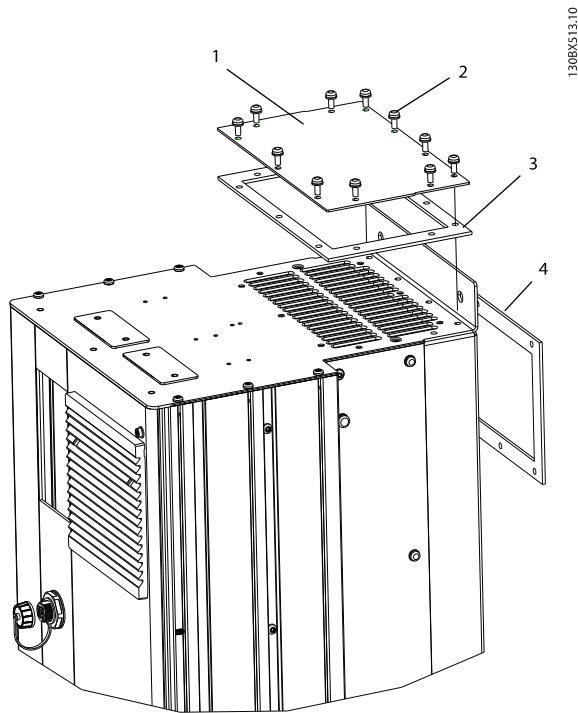

1	Top cover
2	M5x12 screws
3	Gasket, top cover
4	Gasket, cut out

Illustration 1.4 Installing the Top Plate Assembly

1.4.4 Creating Vent Openings

Before attaching the frequency converter to the back panel of the enclosure, modifications must be made to the back panel.

1. Determine where the vent openings and the screw holes are located in the back of the enclosure. Refer to the dimensions provided in *Illustration 1.5 - Illustration 1.6*.
2. Cut out the intake and exhaust openings in the back of the enclosure. The openings must match to the intake and exhaust vent openings of the frequency converter.
3. Drill 6 (D3h) or 8 (D4h) screw holes around the exhaust vent opening in the back panel of the enclosure.
4. Drill 4 screw holes around the intake vent opening in the back panel of the enclosure.

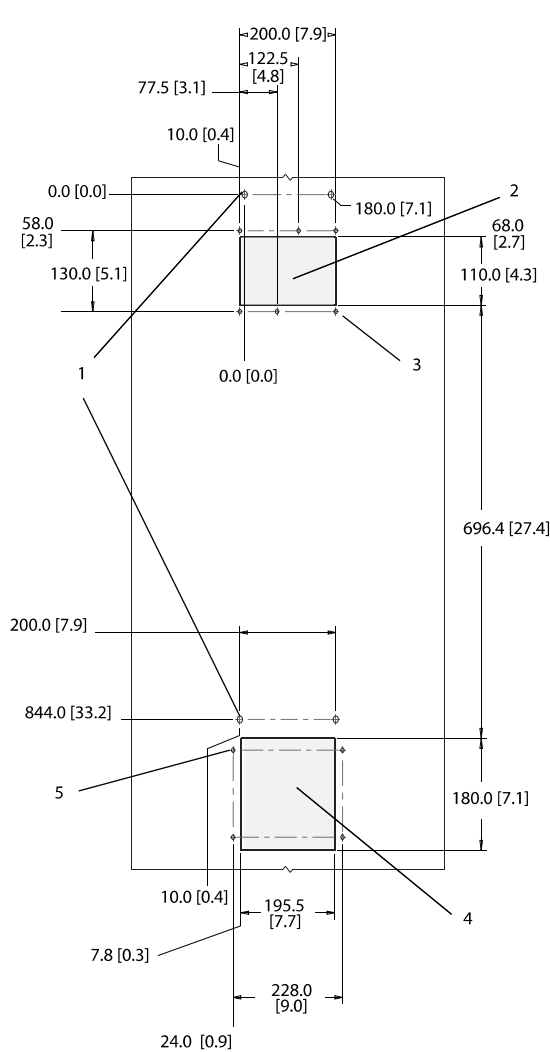

130BX631.10

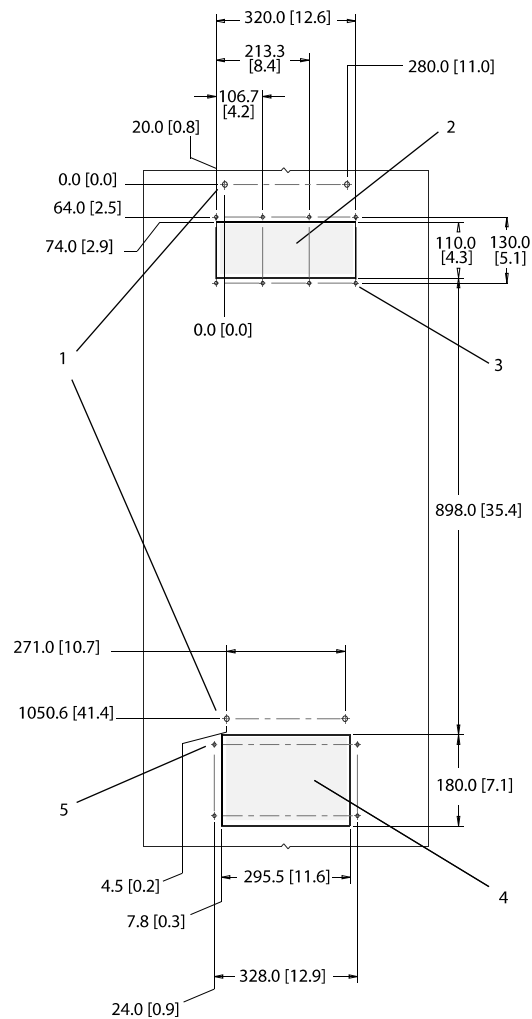

130BX632.10

1	Fastener locations to mount frequency converter to enclosure (4)
2	Rear exhaust vent opening
3	M5 screw holes around exhaust vent (6)
4	Rear intake vent opening
5	M5 screw holes around intake vent (4)

1	Fastener locations to mount frequency converter to enclosure (4)
2	Rear exhaust vent opening
3	M5 screw holes around exhaust vent (8)
4	Rear intake vent opening
5	M5 screw holes around intake vent (6)

Illustration 1.5 Vent Dimensions, D3h

Illustration 1.6 Vent Dimensions, D4h

1.4.5 Mounting the Unit in the Enclosure

Refer to *Illustration 1.7* for the following steps.

1. Place the gasket (1) around the exhaust vent opening (2) on the back panel of the enclosure. Make sure the enclosure and gasket screw holes line up.
2. Assemble the 2 base mounting plates by attaching the 38 mm [1.5 in] gasket (5) onto the 38 mm [1.5 in] base mounting plate (6). Put aside for later use.
3. Secure the top of the frequency converter to the enclosure using the previous fasteners.
4. Secure the base of the frequency converter to the enclosure. Place one base mounting plate on each mounting point, gasket side facing the frequency converter. Reattach using the previous fasteners.

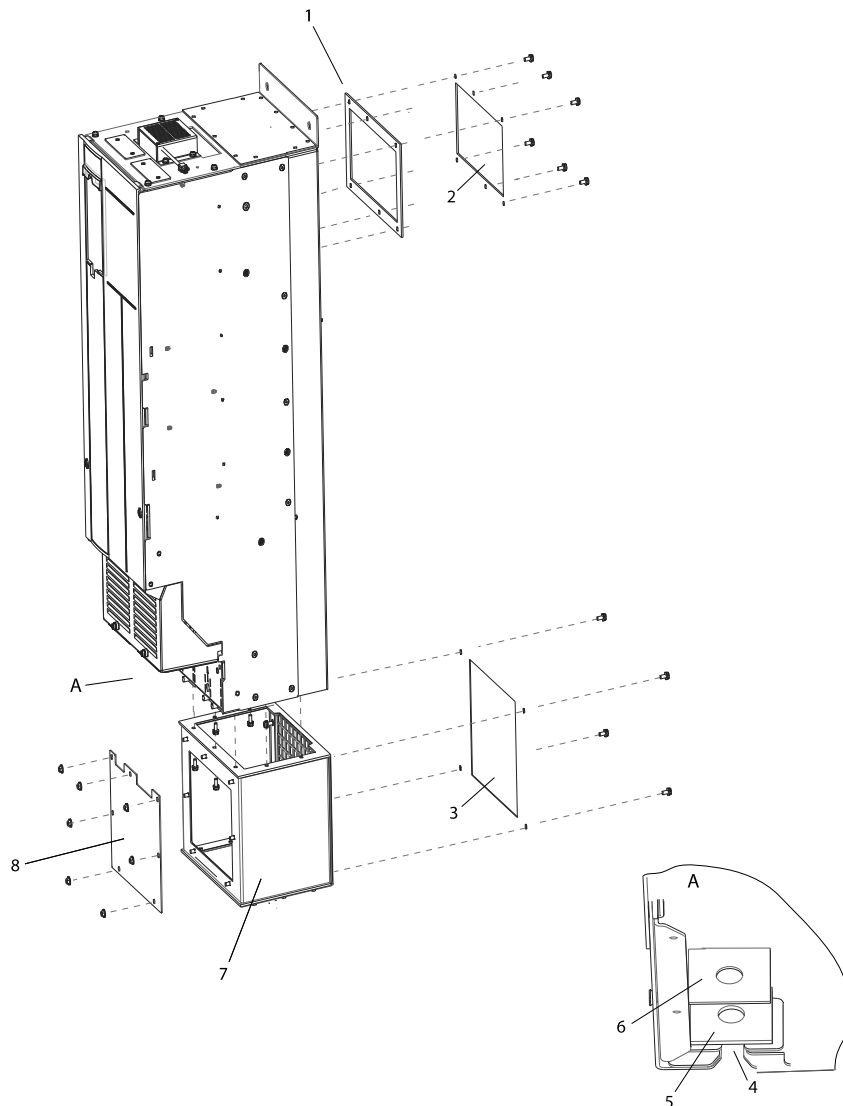

101EESX00E1

1	Gasket, between adapter plate and top of frequency converter	5	Gasket, base mounting plate, 38 mm [1.5 in]
2	Exhaust vent opening in back panel of enclosure	6	Base mounting plate, 38 mm [1.5 in]
3	Intake vent opening in back panel of enclosure	7	Duct assembly
4	Cut-out in base of frequency converter	8	Back cover for duct assembly

Illustration 1.7 Exploded View of Mounting Components

1.4.6 Installing the Duct Covers on the Enclosure

1. Place the sticky side of the exhaust cover gasket (1) on the back side of the exhaust duct cover (2). Make sure that the holes in the gasket and enclosure line up. Refer to *Illustration 1.4*.
2. Place the sticky side of the strip gasket (4) on the lower tab of the cover plate (3).
3. Secure the exhaust duct cover (2) to the enclosure with the 5 (D3h) or 6 (D4h) M5x18 screws. Torque to 2.3 N-m [20 in-lb].
4. Fasten the cover plate (3) to the exhaust duct cover using 6 M5x12 screws. Torque to 2.3 N-m [20 in-lb].
5. Place the sticky side of the exhaust cover gasket (5) on the back side of the intake duct cover. Refer to *Illustration 1.4*.
6. Secure the intake duct cover to the back of the enclosure and through the base duct assembly with 4 M5x18 screws. Secure the screws with M5 nuts (not included) from inside the base duct assembly. Torque to 2.3 N-m [20 in-lb]. Refer to *Illustration 1.7*.
7. Fasten the cover plate (7) to the intake duct cover using 6 M5x12 screws. Torque to 2.3 N-m [20 in-lb].
8. Attach the back cover plate to the base duct assembly. Secure with 7 (D3h) or 8 (D4h) M5 nuts. Torque to 2.3 N-m [20 in-lb]. Refer to *Illustration 1.7*.
9. Reconnect the wiring. For more set-up information, refer to the operating instructions.

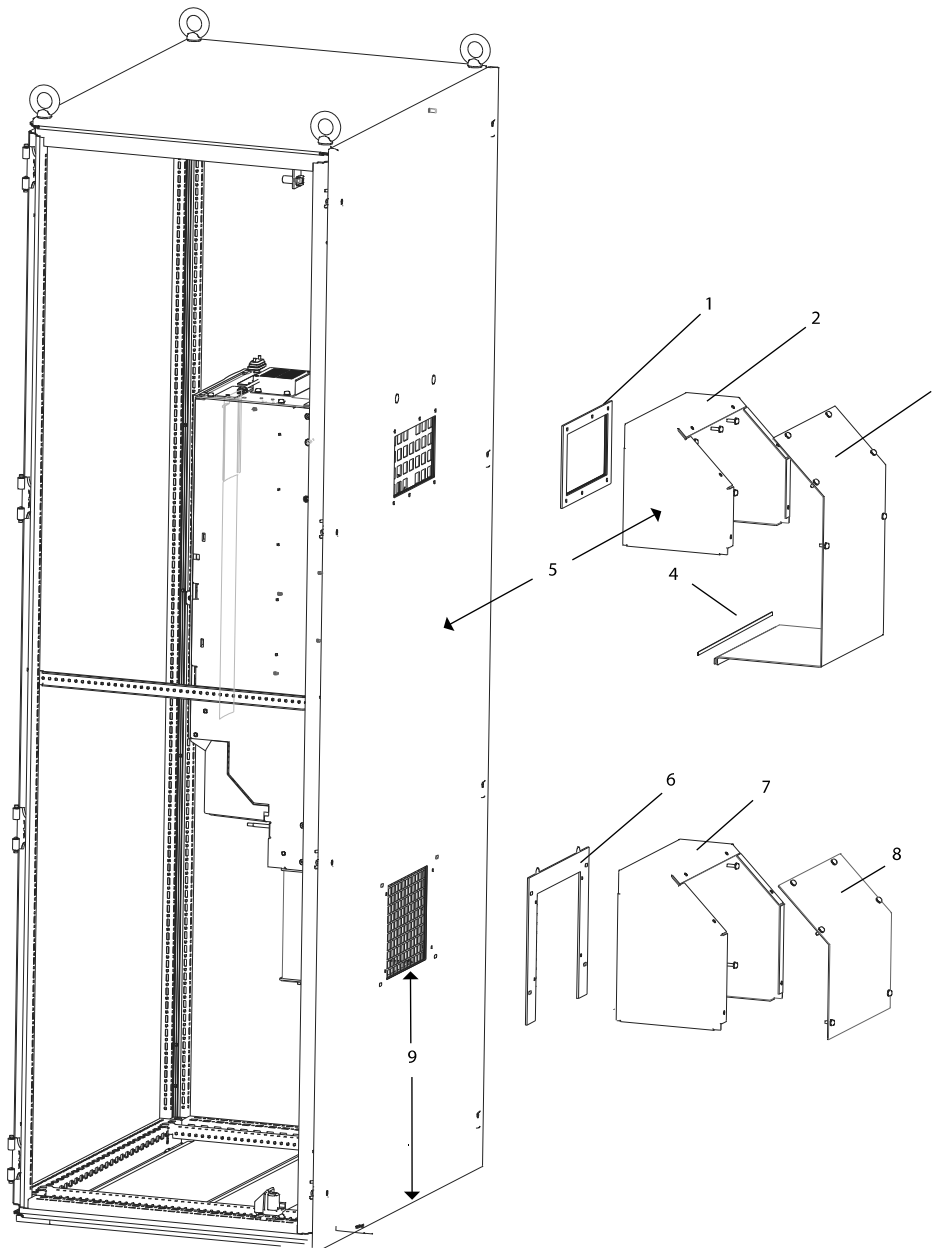

1	Gasket, exhaust duct cover	6	Gasket, intake duct cover
2	Cover, exhaust duct	7	Cover, intake duct
3	Plate, exhaust cover	8	Plate, intake cover
4	Gasket, strip	9	Minimum clearance from intake duct to floor, 225 mm [9 in.]
5	Minimum side clearance, 300 mm [12 in.]		

Illustration 1.8 Installing Duct Cover Assemblies on Enclosure

Danfoss can accept no responsibility for possible errors in catalogues, brochures and other printed material. Danfoss reserves the right to alter its products without notice. This also applies to products already on order provided that such alterations can be made without subsequential changes being necessary in specifications already agreed. All trademarks in this material are property of the respective companies. Danfoss and the Danfoss logotype are trademarks of Danfoss A/S. All rights reserved.

