

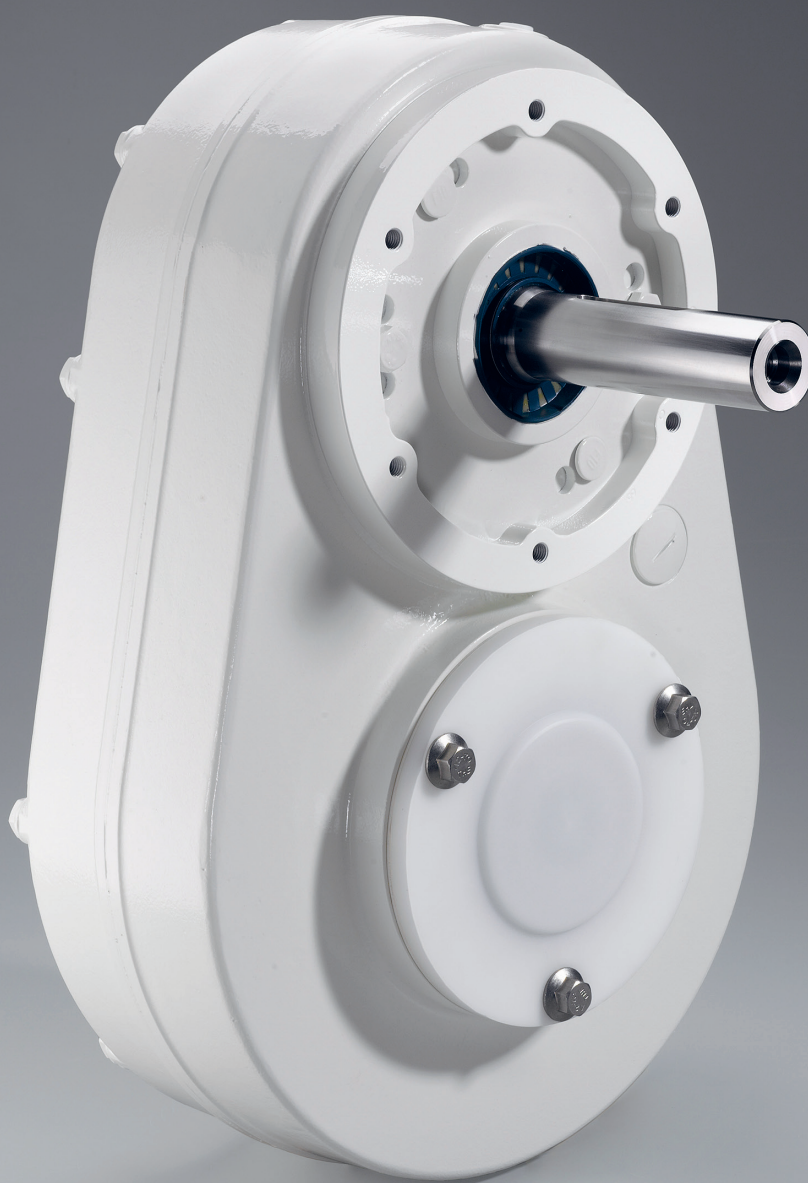

Installation Guide

VLT[®] OneGearDrive ExtensionBox[™]



Contents

1 Safety Warnings	2
1.1 Purpose of this Installation Guide	2
1.2 Safety Symbols	2
1.3 Intended Use	2
1.4 Qualified Personnel	2
1.5 Safety Precautions	2
1.6 Service and Support	2
2 Installation	3
2.1 Items Supplied	3
2.2 Mounting	3
2.2.1 Torque Arm	3
2.2.2 ExtensionBox	4
2.2.3 VLT® OneGearDrive	5
3 Specifications	8
3.1 General Specifications and Environmental Conditions	8
3.2 Dimensions	8
3.2.1 ExtensionBox	8
3.2.2 Adapter Flange	9
3.2.3 Torque Arm for ExtensionBox	9

1 Safety Warnings

1.1 Purpose of this Installation Guide

The purpose of this installation guide is to describe the installation of the VLT® OneGearDrive ExtensionBox.

NOTICE

The information is limited to that required for qualified personnel in normal working situations. Contact Danfoss for further assistance.

The full operating instructions with more detailed information are available on the Danfoss website: vlt-drives.danfoss.com/Support/Technical-Documentation/

Compliance with the information in this installation guide is a prerequisite for:

- Trouble-free operation.
- Recognition of product liability claims.

Therefore, read this manual before working on or with the OneGearDrive.

VLT® is a registered trademark.

1.2 Safety Symbols

The following symbols are used in this manual:

▲WARNING

Indicates a potentially hazardous situation that could result in death or serious injury.

▲CAUTION

Indicates a potentially hazardous situation that could result in minor or moderate injury. It can also be used to alert against unsafe practices.

NOTICE

Indicates important information, including situations that can result in damage to equipment or property.

1.3 Intended Use

The OneGearDrive is intended for commercial installations unless otherwise expressly agreed. It complies with the standards of the series EN 60034/DIN VDE 0530. Use in a potentially explosive atmosphere is forbidden if not expressly intended for this purpose. The OneGearDrive is

designed for ambient temperatures from –20 °C to 40 °C and for installation heights up to 1000 m above sea level.

Danfoss assumes no responsibility of any sort for damage attributable to improper use.

▲CAUTION

Low voltage machines are components for installation in machines in the sense of the machinery directive 2006/95/EC.

- Do not use the machine until conformity of the final product with this directive is established (refer to EN 60204-01).

1.4 Qualified Personnel

All necessary work on electric drive units must only be performed by adequately qualified personnel (for example, electrical engineers as specified in draft EN 50 110-1/DIN VDE 0105), who have the operating instructions provided and other product documentation available during any corresponding work, and who are obliged to abide by the instructions contained therein. Qualified personnel are persons who are authorised due to training, experience, and instruction, as well as their knowledge of relevant standards, rules, accident-prevention regulations, and operating conditions.

1.5 Safety Precautions

▲WARNING

HIGH VOLTAGE

High voltage, which can lead to death or serious injury, is present on the connectors.

- Before working on the power connectors (disconnecting or connecting the cable to the OneGearDrive), disconnect the supply to the frequency converter and wait for the discharge time to elapse (see the frequency converter operating instructions).
- Installation, start-up, maintenance, and decommissioning must only be performed by qualified personnel.

1.6 Service and Support

Contact the local service representative for service and support:

vlt-drives.danfoss.com/Support/Service/

2 Installation

2.1 Items Supplied

- VLT® OneGearDrive ExtensionBox
- Hollow shaft cover
- Accessory bag
 - Retaining ring
 - Disc
 - 3 screws for hollow shaft cover (M12 x 30)
 - 3 plastic discs
 - Plastic cap
- Adapter flange kit
 - Adapter flange
 - 6 adapter screws (M10 x 30)
 - 6 washers
 - 6 adapter screws (M12 x 25)
- Torque arm set
 - Torque arm
 - Mounting set
 - 6 torque arm screws (M12 x 30)

2.2.1 Torque Arm

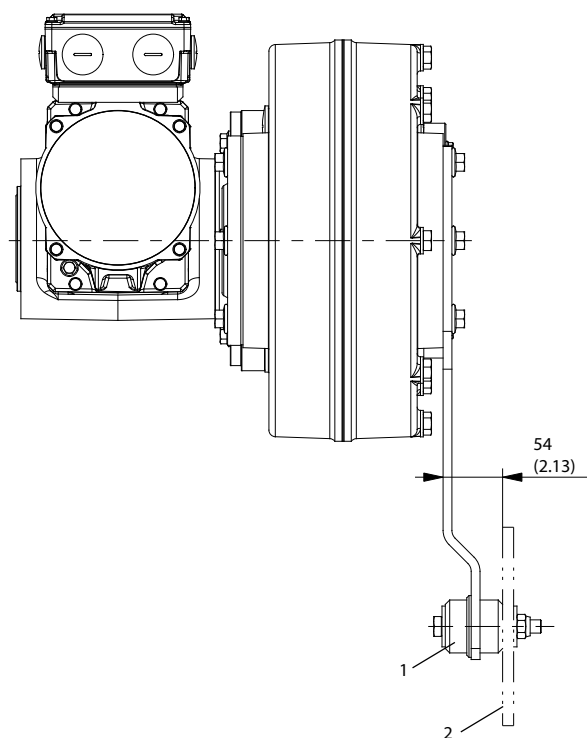

1	Torque arm fastening set
2	Customer support frame

Illustration 2.1 ExtensionBox with Torque Arm and OneGearDrive

2.2 Mounting

The ExtensionBox can only be adapted to 40 mm conveyor shafts and OneGearDrives with a 40 mm hollow shaft.

The minimum shaft length is 130 mm and the maximum shaft length is 150 mm.

All other specifications can be found in *chapter Assembly Kit* in the *VLT® OneGearDrive Operating Instructions*.

Take the dimensions from *chapter 3.2.3 Torque Arm for ExtensionBox* to determine the position of the fastening set. Also see *chapter 2.2.3 VLT® OneGearDrive* for optional mounting positions.

2

Assemble the torque arm as shown in *Illustration 2.2*.

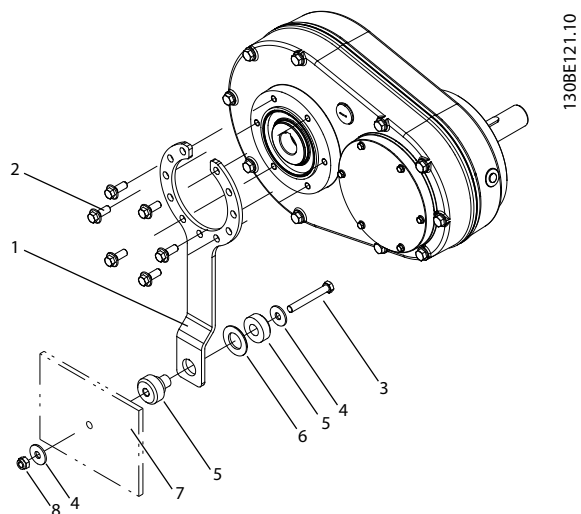

Position	Quantity	Item	Comments
1	1	Torque arm	–
2	6	Torque arm screw	DIN 6921, M12 x 30, tightening torque: 35 Nm
3	1	Screw	ISO 4017, M12 x 90
4	2	Washer	DIN 9021, A13
5	1	Damper	–
6	1	Washer	ISO 7090, M30
7	–	Customer support frame	–
8	1	Hexagon nut	DIN 985, M12, tightening torque: 43 Nm

Illustration 2.2 Assembly View of the ExtensionBox with Torque Arm

2.2.2 ExtensionBox

- Grease the conveyor shaft.
- Mount the ExtensionBox to the conveyor shaft and fix it with the delivered retaining ring and disc.

NOTICE

The screw [3] is not supplied and depends on the conveyor shaft length. Refer to the *chapter Assembly Kit* in the *VLT® OneGearDrive Operating Instructions* for further information.

- Assemble the ExtensionBox in 30° steps (see *chapter 2.2.3 VLT® OneGearDrive*).
- Close the hollow shafts with the cover (see *Illustration 2.4*).

2.2.3 VLT® OneGearDrive

1. Assemble the adapter flange to the OneGearDrive as shown in *Illustration 2.3*.

NOTICE

Table 2.1 shows the possible adapter flange positions for the various ExtensionBox mounting positions. Also use this table for mirror inverted mounting positions.

ExtensionBox mounting position	OneGearDrive mounting position	Adapter flange screw positions
		
		

Table 2.1 Possible Adapter Flange Positions

2. Tighten all 6 screws as shown in *Illustration 2.3*.
3. Grease the ExtensionBox shaft.
4. Mount the OneGearDrive to the ExtensionBox shaft as shown in *Illustration 2.4*.

2

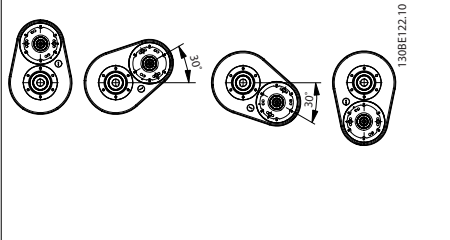
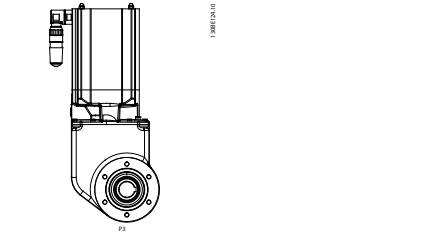
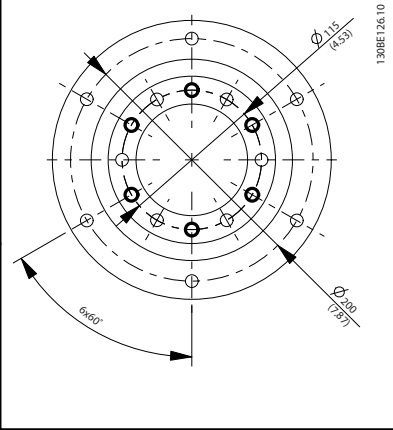
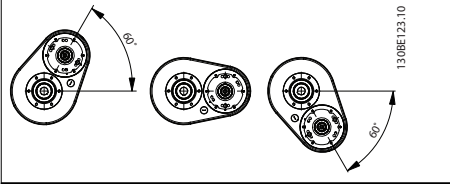
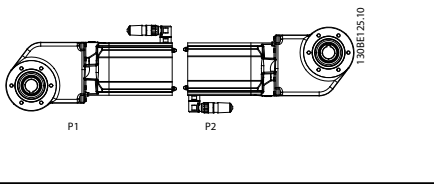
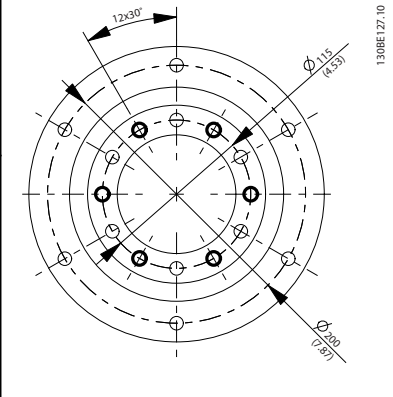
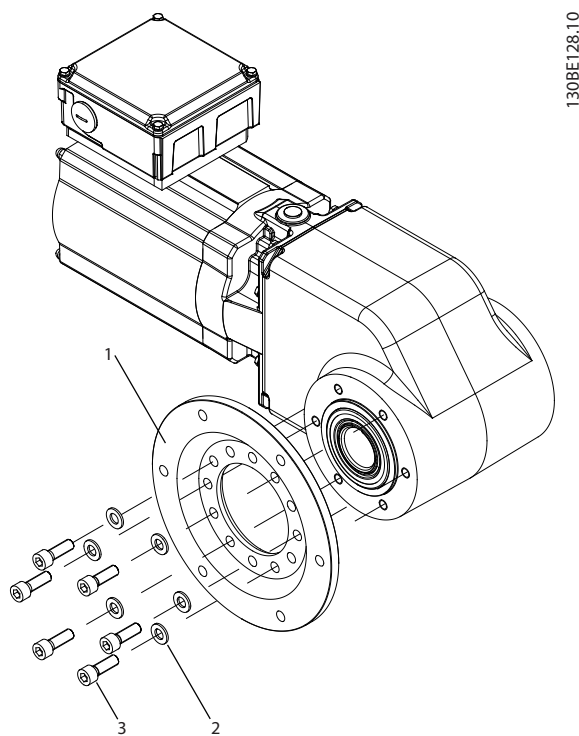

Position	Quantity	Item	Comments
1	1	Adapter	-
2	6	Washer	DIN 125, A10.5
3	6	Adapter screw	DIN 912, M10 x 30, tightening torque: 20 Nm

Illustration 2.3 Assembly of the Adapter Flange to the OneGearDrive

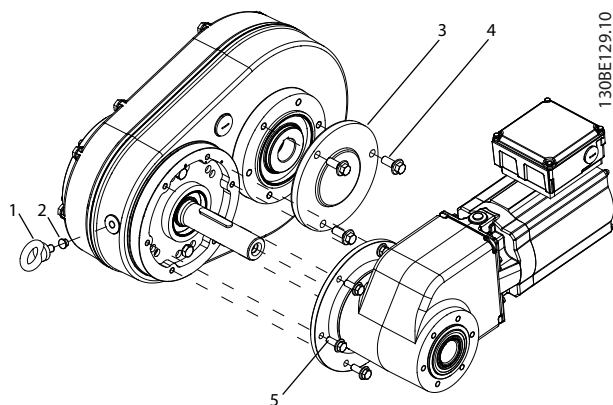

Position	Quantity	Item	Comments
1	1	Eyebolt	DIN 580, C15, M12
2	1	Plastic cap	–
3	1	Hollow shaft cover with seal	–
4	3	Cover screw	DIN 6921, M12 x 30, tightening torque: 6 Nm
5	1	Adapter flange (mounted to OneGearDrive)	–

Illustration 2.4 Assembly of the Adapter Flange to the ExtensionBox

5. Fasten the adapter flange [5] with the adapter screws (supplied).
6. Remove the eye bolt [1] from the ExtensionBox and the OneGearDrive.
7. Fit the plastic cap [2] (supplied) to close the hole on the ExtensionBox.
8. Fit the hollow shaft cover [3] to the ExtensionBox.

Refer to the *VLT® OneGearDrive Operating Instructions* for further information.

3 Specifications

3.1 General Specifications and Environmental Conditions

3

Ratio i	3.11
Protection rating	IP54
M _{LT} [Nm]	0–850
n _{LT} [RPM]	0–31
Weight [kg]	44

Table 3.1 General Specifications and Environmental Conditions

3.2 Dimensions

3.2.1 ExtensionBox

All dimensions are in mm (inch).

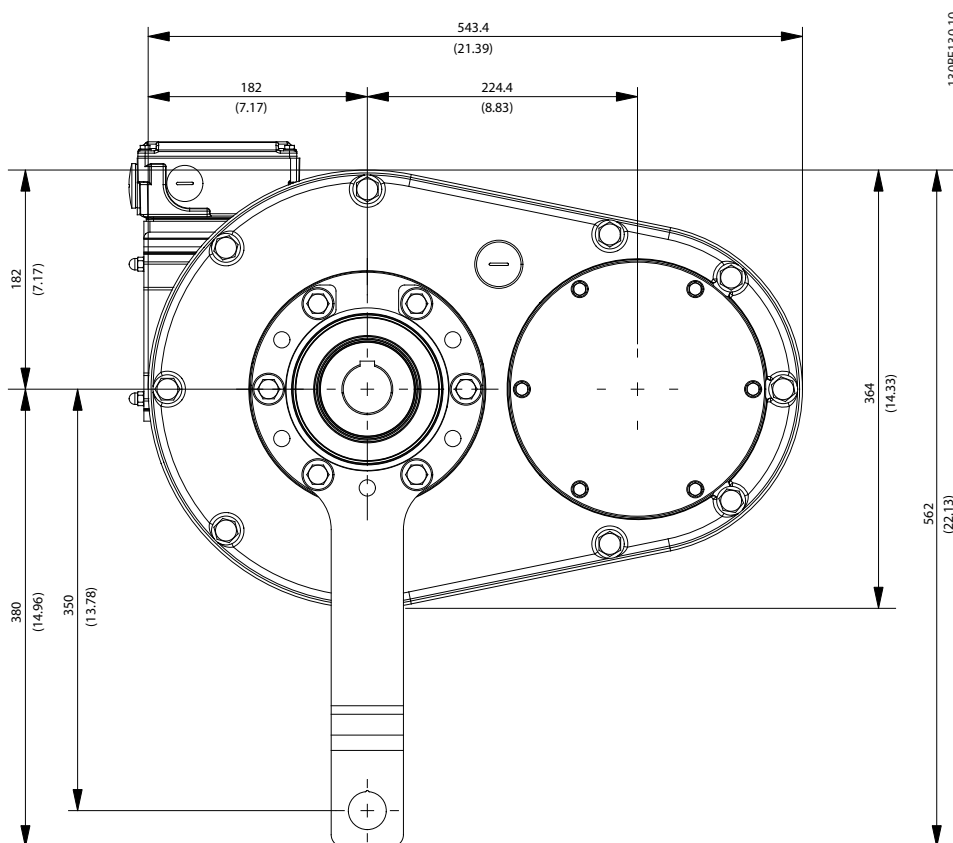

Illustration 3.1 ExtensionBox Dimensions

3.2.2 Adapter Flange

All dimensions are in mm (inch).

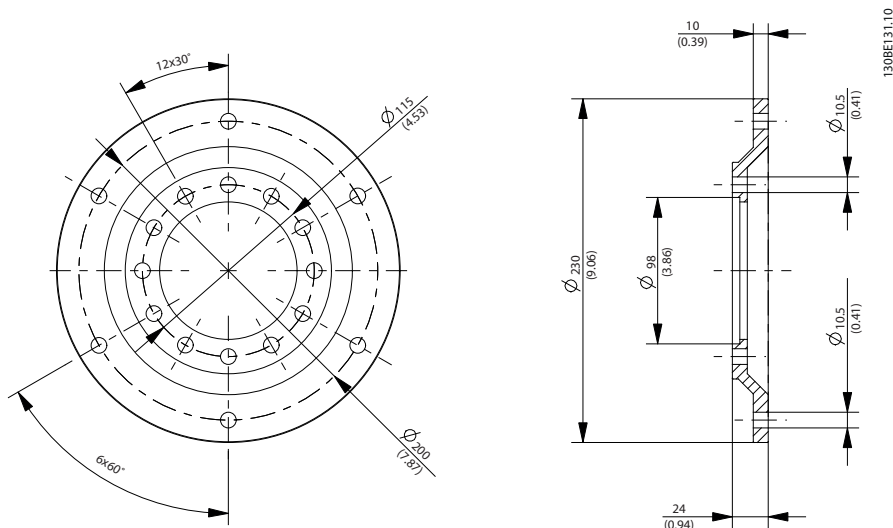

Illustration 3.2 Adapter Flange Dimensions

3.2.3 Torque Arm for ExtensionBox

All dimensions are in mm (inch).

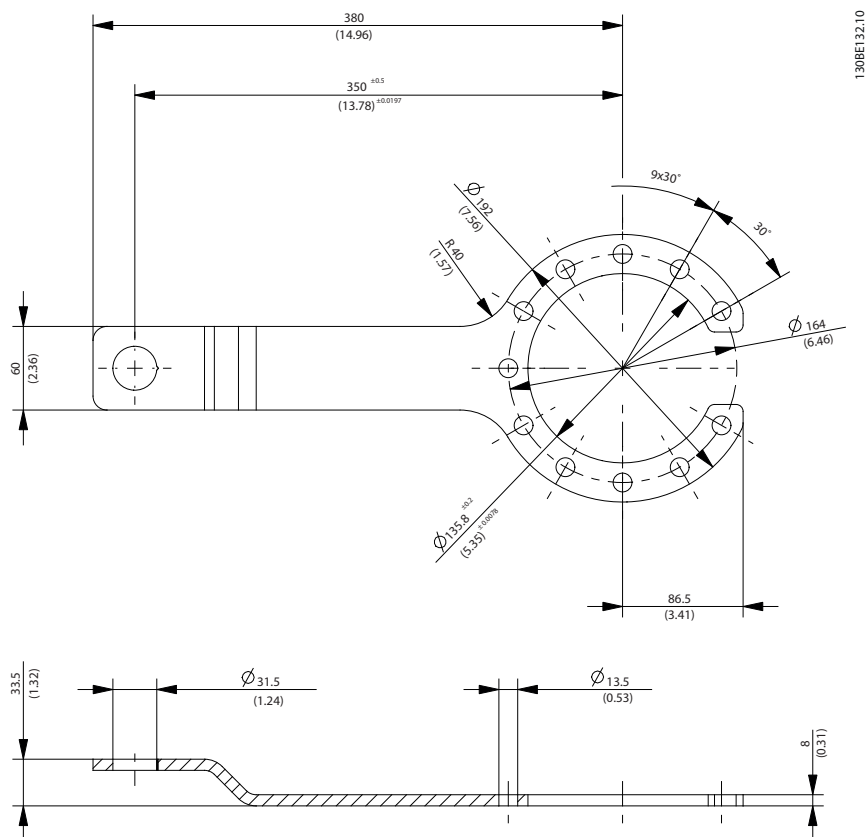

Illustration 3.3 Torque Arm Dimensions



.....
Danfoss can accept no responsibility for possible errors in catalogues, brochures and other printed material. Danfoss reserves the right to alter its products without notice. This also applies to products already on order provided that such alterations can be made without subsequential changes being necessary in specifications already agreed. All trademarks in this material are property of the respective companies. Danfoss and the Danfoss logotype are trademarks of Danfoss A/S. All rights reserved.
.....

Danfoss A/S
Ulsnaes 1
DK-6300 Graasten
vlt-drives.danfoss.com

