

# Installation Instructions

## In-back/Out-back Cooling Kit for VLT® Parallel Drive Modules

### VLT® Series FC 102, FC 202, and FC 302

#### Description

The in-back/out-back cooling kit is designed for the specific VLT® HVAC Drive FC 102, VLT® AQUA Drive FC 202, and VLT® AutomationDrive FC 302 D4h-size VLT® Parallel Drive Modules mounted in a Rittal TS8 enclosure. The kit directs air in from and out of the back of the unit. See *Illustration 1.1*.

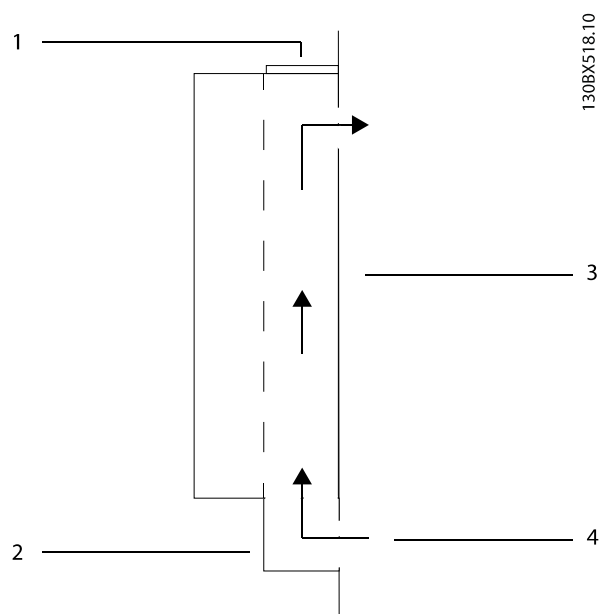

#### Items Supplied

##### Top plate assembly

- Top cover (1)
- Gasket, top cover (1)
- Gasket, cut out (1)
- Screws, M5x12 (11)

##### Enclosure mounting assembly

- Base mounting plate, 38 mm (1.5 in.) (2)
- Gasket, base mounting plate (2)
- Gasket, frequency converter exhaust vent (1)
- Screws, M5x12 (11)
- Nuts, M10 (4)
- Gasket, enclosure exhaust vent (1)
- Gasket, enclosure intake vent (1)
- Torx screws, M5x12 (14)

1	Top plate assembly
2	Base duct assembly
3	Mounting backplate
4	Back-channel airflow

Illustration 1.1 Direction of Airflow with the Kit Installed

#### Kit Part Number

Part number	Kit description
176F6493	In-back/Out-back Cooling Kit for the VLT® Parallel Drive Modules (2-drive system)

Table 1.1 Part Number for the VLT® Parallel Drive Modules In-back/Out-back Cooling Kit

Lower duct assembly

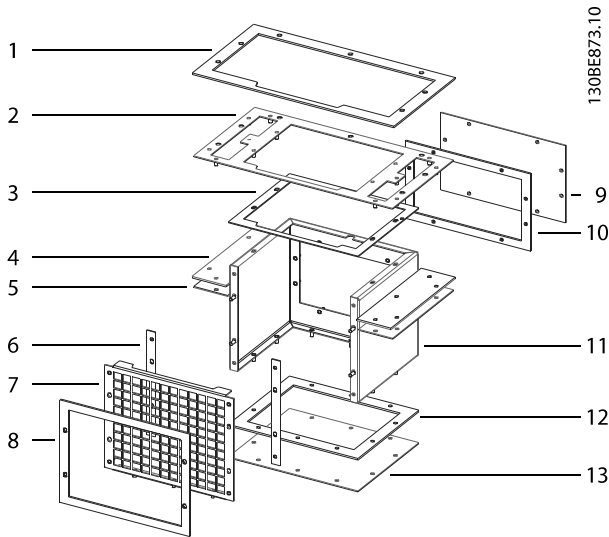

1	Gasket between drive module and top plate (1)
2	Top plate (1)
3	Gasket between duct enclosure and top plate (1)
4	Gasket, top side (2)
5	Top side, cover (2)
6	Gasket, side of grill (2)
7	Grill (1)
8	Gasket between grill and mounting backplate (1)
9	Front cover plate (1)
10	Gasket, between duct enclosure and front cover plate (1)
11	Duct enclosure (1)
12	Gasket between duct enclosure and base cover plate (1)
13	Base cover plate (1)
-	Screws, M5x12 (4)
-	Torx screws, M5x16 (7)
-	Nuts, M5 (36)

Illustration 1.2 Lower Duct Assembly for 1 Drive Module

Safety

**⚠ WARNING**

**DISCHARGE TIME**

The frequency converter contains DC-link capacitors, which can remain charged even when the unit is off. High voltage can be present even when the warning indicator lights are off. Failure to wait 20 minutes after power has been removed before performing service or repair work, could result in death or serious injury.

- Stop the motor.
- Disconnect the AC mains, permanent magnet type motors, and remote DC-link supplies, including battery back-ups, UPS, and DC-link connections to other frequency converters.
- Wait 20 minutes for the capacitors to discharge fully, before performing any service or repair work.
- Measure the voltage level to verify full discharge.

Installation

**NOTICE**

If both a bus bar kit and a back-channel cooling kit are being installed in the cabinet, install the back-channel cooling kit first.

**NOTICE**

**APPROVALS AND CERTIFICATIONS**

This VLT® Parallel Drive Modules back-channel cooling kit is UL 508C compliant. These installation instructions describe how to install the back-channel cooling kit which, if followed, meet specific agency approvals and certifications. Seek agency approvals or certifications apart from Danfoss if designing and building other configurations.

**NOTICE**

**APPLYING GASKETS**

This kit contains gaskets to ensure a proper seal between metal parts. Before adhering a gasket to a part, check that the part matches the gasket and that no holes are covered. Remove paper backing and place the sticky side on the part.

### Creating Vent Openings in the Mounting Backplate

Refer to *Illustration 1.3* for these steps.

1. Cut out the intake and exhaust openings in the mounting backplate. The openings must match the drive module vent openings.
2. Drill the 12 screw holes around the exhaust (top) vent openings and insert the 12 M5 X 12 pem studs.
3. Drill the 12 screw holes around the intake (bottom) vent openings and insert the 12 M5 X 12 pem studs.

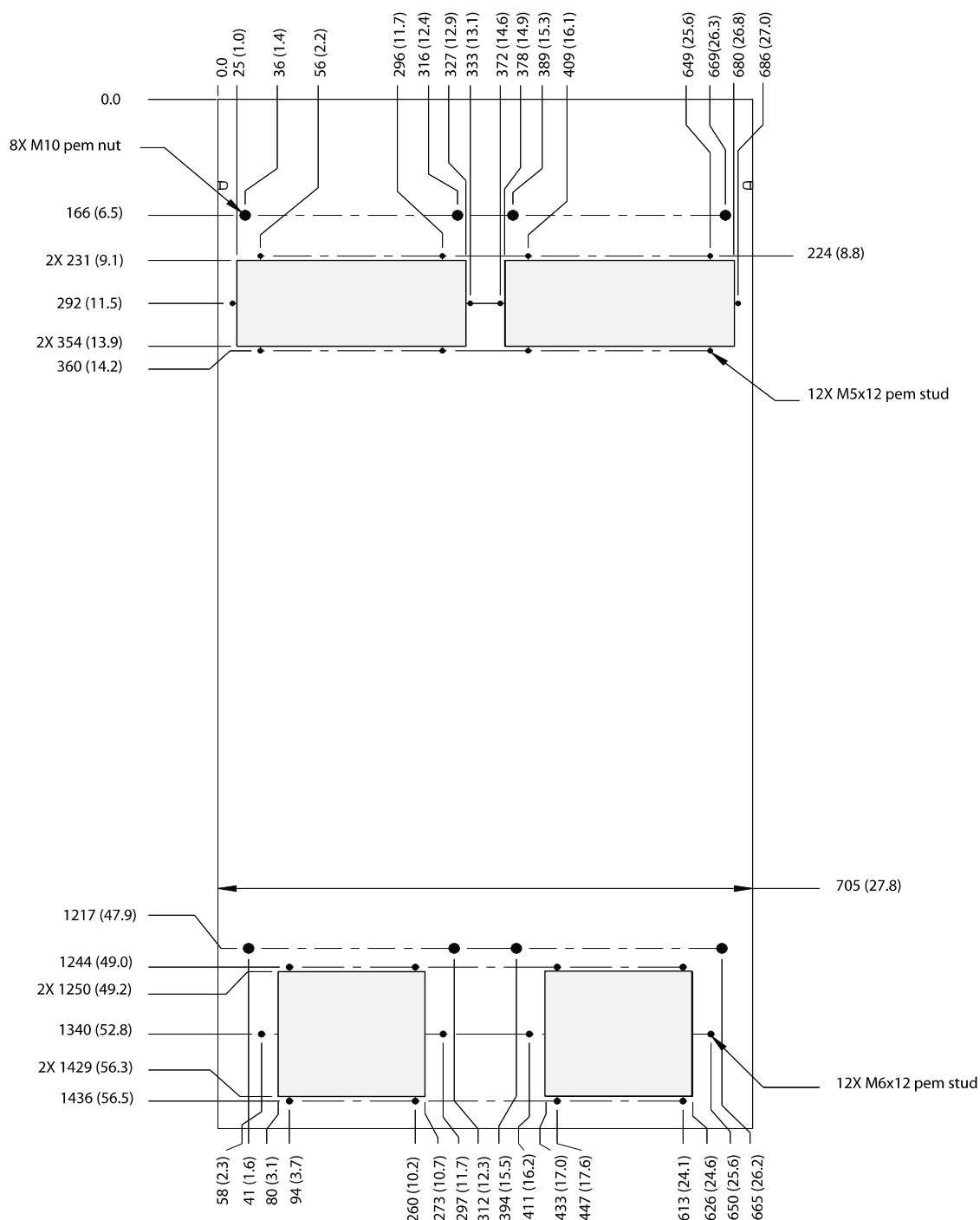

130BE811.10

Illustration 1.3 Vent Dimensions for Mounting Plate

## Assembling the Lower Duct Enclosure

The front cover gasket (10) and front cover plate (9) are not installed during the lower duct assembly. They are installed once the duct is attached to the mounting backplate.

1. Install the left and right side gaskets (6) against the back side of the duct enclosure (11).
2. Place the grill (7) on top of the gaskets. Secure the grill to the enclosure using 4 M5 nuts. Torque to 5.1 Nm (45 in-lb).
3. Install the gasket (8) on top of the grill.
4. On the base of the enclosure, install the gasket (12) and then the base cover plate (13) on the enclosure. Secure with 10 M5 nuts and torque to 5.1 Nm (45 in-lb).
5. On the top of the enclosure, install the gasket (3) and then the top plate (13) on the enclosure. Secure the top plate to the enclosure with 4 M5 nuts. Torque to 5.1 Nm (45 in-lb).
6. Install the gasket (1) on the top plate. Leave the paper backing on the adhesive until ready to install on the drive module.
7. Turn the duct enclosure over so the base of the enclosure is facing up. Install the top side gaskets (4) on the sides of the top plate (2).
8. Place a top side cover (5) on each gasket (4). Secure each cover with 5 M5 nuts and torque to 5.1 Nm (45 in-lb).

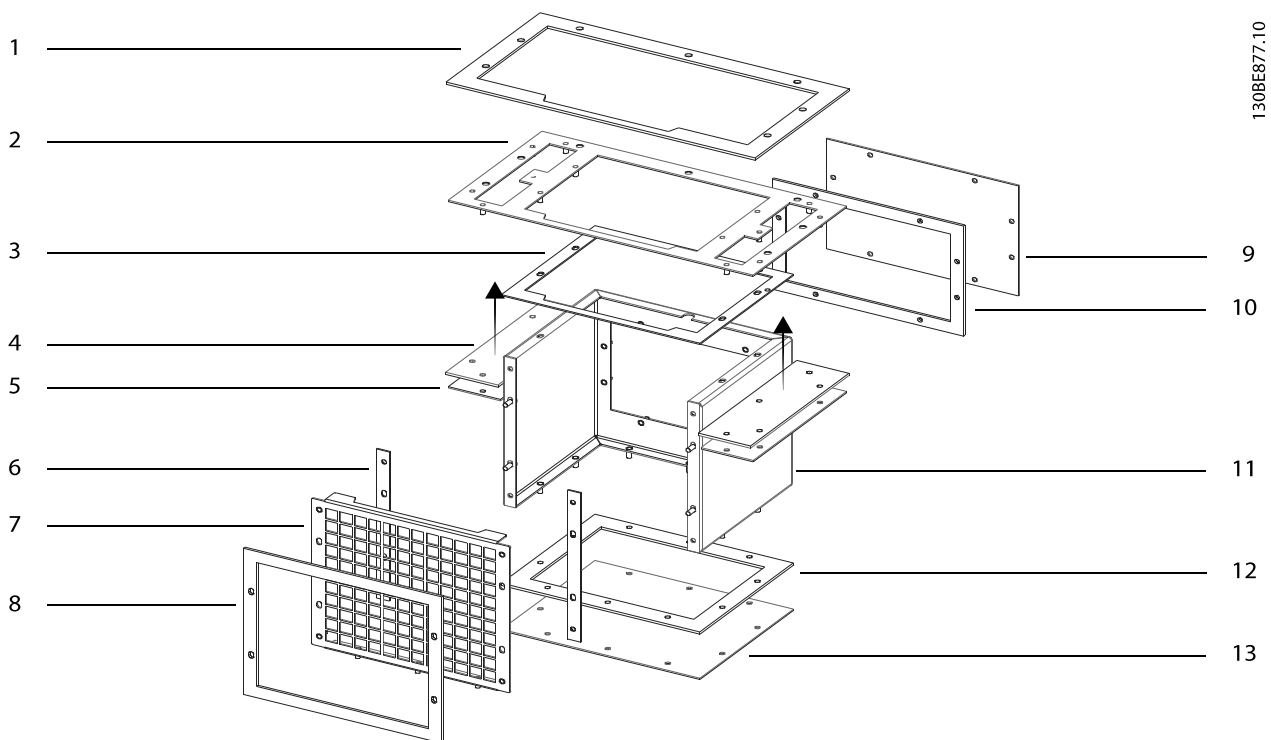

Illustration 1.4 Assembling the Lower Duct Enclosure

1	Gasket between drive module and top plate	8	Gasket between grill and cabinet
2	Top plate	9	Front cover plate
3	Gasket between duct enclosure and top plate	10	Gasket between duct enclosure and front cover plate
4	Gasket, top side	11	Duct enclosure
5	Top side, cover	12	Gasket between duct enclosure and base cover plate
6	Gasket, side of grill	13	Base cover plate
7	Grill	–	–

## Mounting the Drive Modules

1. Install the mounting backplate to the cabinet rails, making sure that the pem studs/nuts are facing toward the back of the enclosure.
2. Install gaskets to the back side of the drive module. Refer to *Illustration 1.5*.
  - 2a Install gasket (3) over the exhaust vent opening.
  - 2b Align the slot gasket (5) with the lower mounting holes in the drive module and install the gasket onto the drive module.
3. Install the base mounting plates. Refer to *Illustration 1.6*.
  - 3a Assemble the 2 base mounting plates by attaching the gasket (4) onto the base mounting plate (5).
  - 3b Insert an M10 screw (6) through the mounting plate/gasket assembly and loosely fasten into the mounting backplate. Perform this step again for the other mounting plate/gasket assembly. Make sure that the screws are secure since the base of the drive module rests on these screws.
4. Slightly lean the top of the drive module forward and set the cutouts in the base of the module onto the lower 2 M10 screws in the mounting backplate.
5. Slowly push the top of the drive module back against the mounting backplate until the top 2 holes on the module line up with the 2 mounting holes in the mounting backplate. Secure the top of the drive module using 2 M10 screws and torque to 19 Nm (170 in-lb).
6. Torque the M10 screws securing the base of the module to 19 Nm (170 in-lb).
7. Install the top plate assembly. Refer to *Illustration 1.5*.
  - 7a Place the gasket (3) over the grill opening on the top of the unit.
  - 7b Place the top cover (1) over the gasket. Secure it with the 11 screws included in the kit. Torque to 5.1 Nm (45 in-lb).

130BE810.11

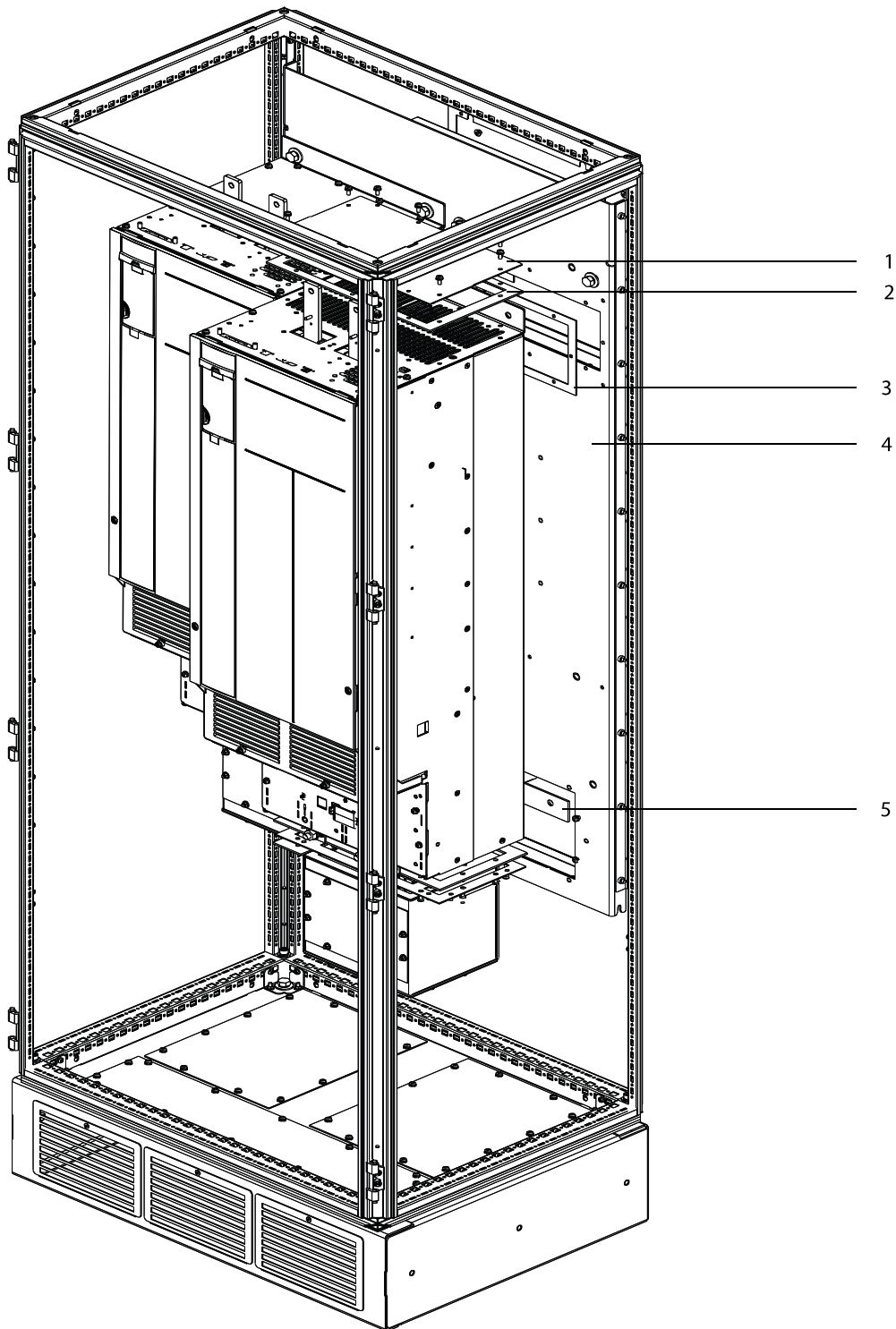

1	Top cover on drive module	4	Mounting backplate
2	Gasket between drive module exhaust and top cover	5	Gasket, slot
3	Gasket, between drive module exhaust and mounting backplate	-	-

Illustration 1.5 Installing the Drive Modules to the Mounting Back Plate

## Installing the Lower Duct Assembly to the Mounting Backplate

Refer to *Illustration 1.6* for the following steps.

1. Remove the paper backing from the top plate gasket.
2. Place the lower duct assembly up against the drive module base, making sure the mounting holes line up.
3. Secure the lower duct assembly to the base of the drive module using 7 M5x16 screws. Torque to 5.1 Nm (45 in-lb).
4. Secure the grill on the lower duct assembly to the mounting backplate using 4 M5x12 screws. Torque to 5.1 Nm (45 in-lb).
5. On the front side of the lower duct, install the front cover gasket (10) and then the front cover plate (9). Refer to *Illustration 1.4*. Secure with 8 M5 nuts and torque to 5.1 Nm (45 in-lb).
6. Install the lower duct assembly for the next drive module.

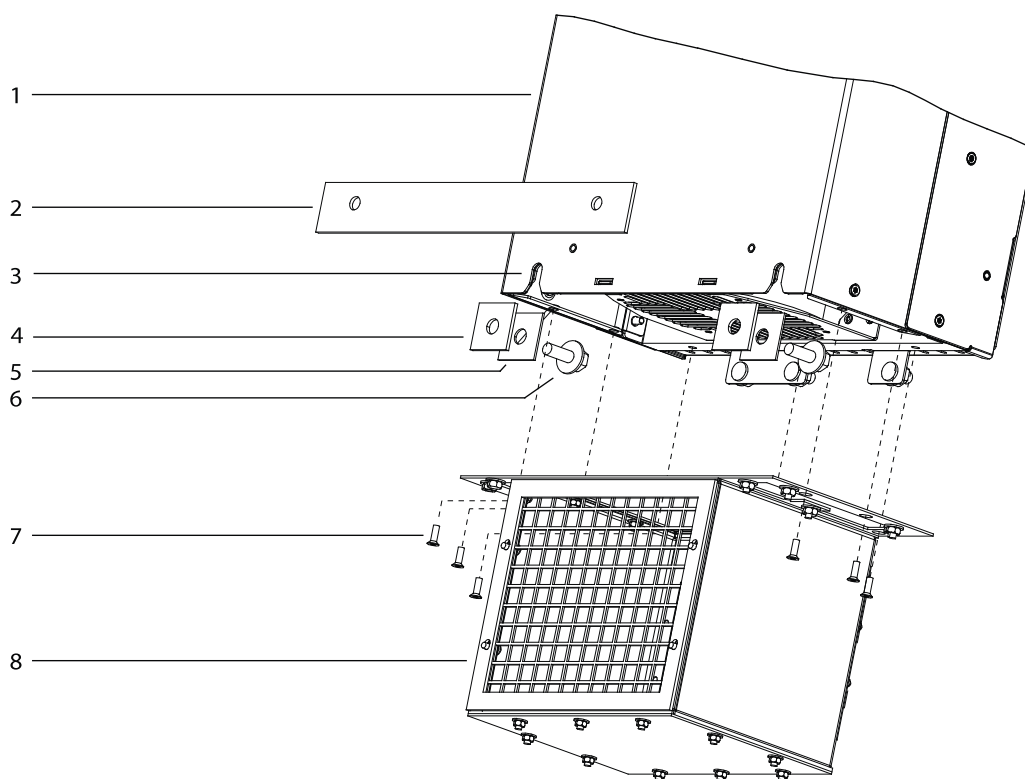

130BE875.11

1	Drive module	5	Base mounting plate, 38 mm (1.5 in)
2	Gasket, slot	6	M10 screw
3	Cutout in drive module base that rests on the M10 screw	7	M5x16 screw
4	Gasket, base mounting plate, 38 mm (1.5 in)	8	Lower duct assembly

Illustration 1.6 Installing the Lower Duct Assembly

## Installing the Back Panel Cover

1. Install a gasket (1) around each exhaust vent opening on the back side of the mounting backplate (4). Refer to *Illustration 1.7*.
2. Install a duct spacer (2) onto each exhaust gasket and secure with 4 M5 nuts. Torque to 5.1 Nm (45 in-lb).
3. Install a gasket (5) around each intake vent opening on the back side of the mounting backplate (4).
4. Install an intake duct spacer (6) onto each intake gasket and secure with 4 M5 nuts. Torque to 5.1 Nm (45 in-lb).
5. Place a gasket (3) onto each exhaust duct spacer.
6. Place a gasket (7) onto each intake duct spacer.
7. Prepare the back panel cover. Refer to *Illustration 1.8*.
  - 7a Cut out the 2 intake and 2 exhaust vent openings in the back panel. The openings must match to the intake and exhaust duct spacer openings.
  - 7b Drill the 16 screw holes around the vent openings.
8. Secure the back panel cover to the frame.
9. Secure the back panel cover to the duct spacers with 16 M5x16 screws. Torque to 5.1 Nm (45 in-lb).



130BE809.10

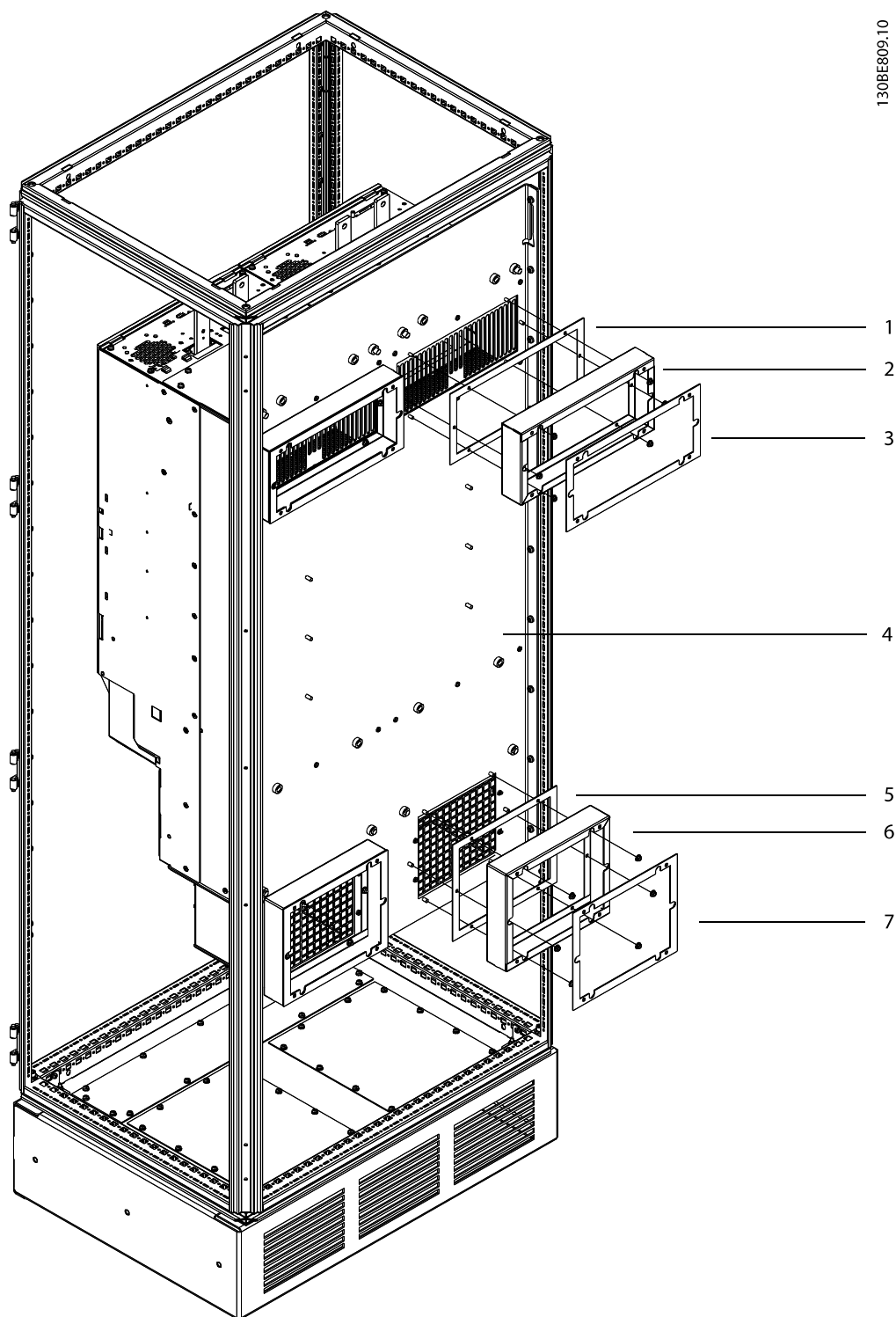

1	Gasket between the mounting backplate and the exhaust duct spacer	5	Gasket between the mounting backplate and the intake duct spacer
2	Duct spacer, exhaust	6	Duct spacer, intake
3	Gasket between the exhaust duct spacer and the back panel	7	Gasket between the intake duct spacer and the back panel
4	Mounting plate	-	-

Illustration 1.7 Installing the Duct Spacers

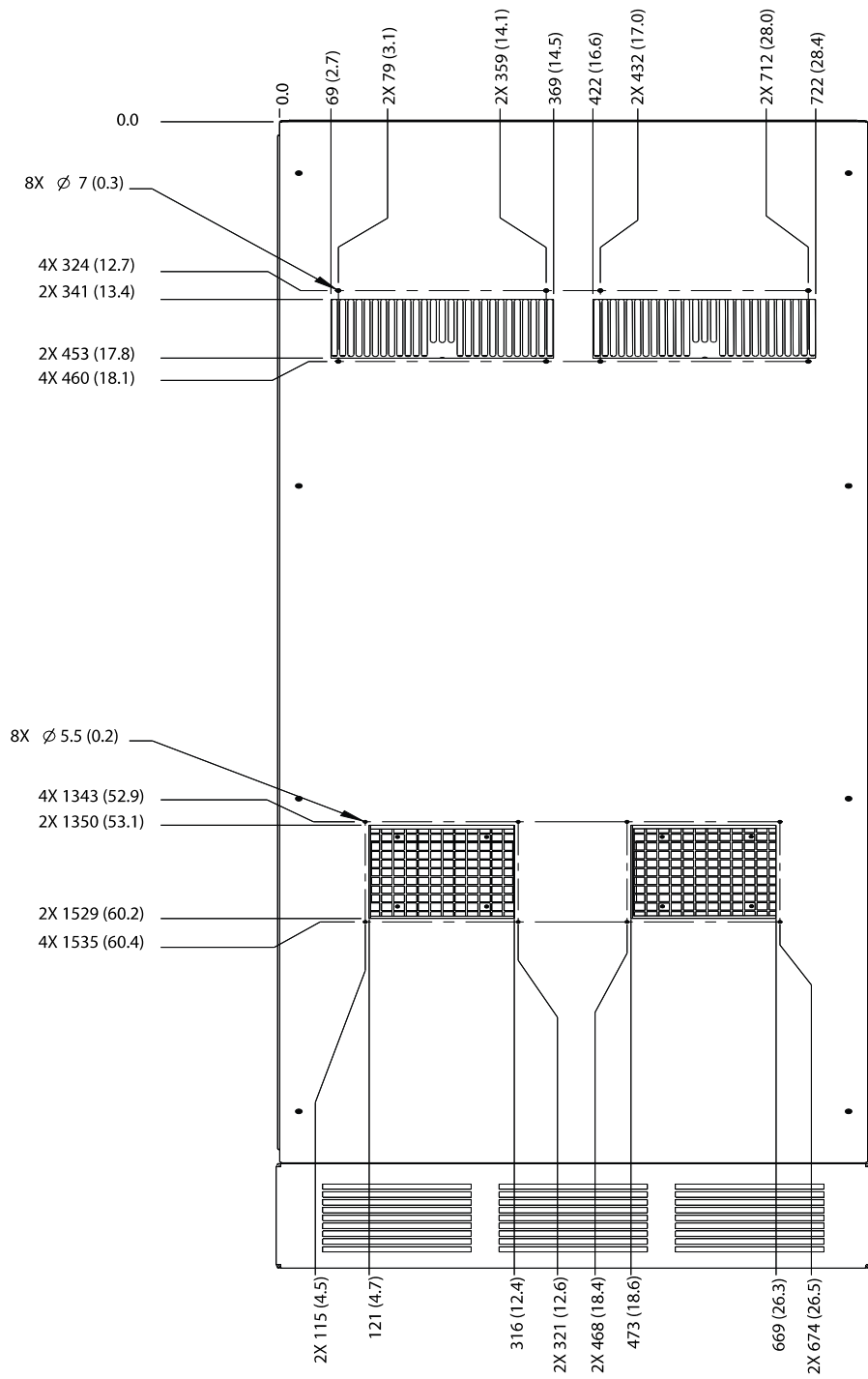

Illustration 1.8 Vent Dimensions for Back Panel Cover

Danfoss can accept no responsibility for possible errors in catalogues, brochures and other printed material. Danfoss reserves the right to alter its products without notice. This also applies to products already on order provided that such alterations can be made without subsequential changes being necessary in specifications already agreed. All trademarks in this material are property of the respective companies. Danfoss and the Danfoss logotype are trademarks of Danfoss A/S. All rights reserved.

