

Installation Instructions

Bus Bar Kit for 6-pulse, 4-drive System

VLT[®] Series FC 102, FC 202, and FC 302

Description

The bus bar kit is designed for the specific VLT[®] HVAC Drive FC 102, VLT[®] AQUA Drive FC 202, and VLT[®] AutomationDrive FC 302 D4h-size VLT[®] Parallel Drive Modules mounted in a Rittal TS8 enclosure. The bus bars in this kit link 4 drive modules in parallel.

Kit Part Number

Part number	Kit description
176F6488	Bus bar kit for the VLT [®] Parallel Drive Modules (6-pulse, 4-drive system)

Table 1.1 Part Number for the VLT[®] Parallel Drive Modules Bus Bar Kit

Items Supplied

The kit contains the following parts:

- Nut with integrated washer, M5 (20)
- Nut with integrated washer, M8 (30)
- Nut with integrated washer, M10 (24)
- Screw, M5 x 12 mm (80)
- Screw with integrated washer, M10 x 30 (24)
- Stand-off, M5 x 25 (48)
- Ground bus bar, 800 mm (2)
- Ground plate (2)
- Ground jumper plate (4)
- Ground jumper bus bar (4)
- Ground clamp (2)
- EMI/EMC bracket, left (4)
- EMI/EMC bracket, right (4)
- EMI/EMC bracket, front (4)
- EMC shield, lower (2)
- Cabinet-to-cabinet DC-link connector (2)
- Cabinet-to-cabinet ground connector (1)

DC bus assembly

- L-brackets (4)
- DC-link jumper bus bar (-) (4)
- Jumper bus bar (+) (4)
- DC bus support plate (2)
- DC-link bus bar (4)

AC bus bar assembly

- Brake terminal, left (4)
- Brake terminal, right (4)
- Brake terminal (4)
- Solid AC bus bar, (12)
- Mains bus bar support bracket (2)
- AC bus bar assembly bracket (2)
- Mains bus bar S-bracket (2)
- Flexible AC bus bars (24)
- Support for brake terminals (2)
- Side support (4)

Safety

⚠ WARNING

DISCHARGE TIME

The frequency converter contains DC-link capacitors, which can remain charged even when the unit is off. High voltage can be present even when the warning indicator lights are off. Failure to wait 20 minutes after power has been removed before performing service or repair work, could result in death or serious injury.

- Stop the motor.
- Disconnect the AC mains, permanent magnet type motors, and remote DC-link supplies, including battery back-ups, UPS, and DC-link connections to other frequency converters.
- Wait 20 minutes for the capacitors to discharge fully, before performing any service or repair work.
- Measure the voltage level to verify full discharge.

Installation

NOTICE

If both a bus bar kit and a back-channel cooling kit are being installed in the cabinets, install the back-channel cooling kit first.

NOTICE

APPROVALS AND CERTIFICATIONS

This VLT® Parallel Drive Modules bus bar kit is UL 508C compliant. These installation instructions describe how to install Danfoss-supplied bus bars which, if followed, meet specific agency approvals and certifications. Seek agency approvals or certifications apart from Danfoss if designing and building other configurations.

Installing DC-link Bus Bars

1. Install 1 L-bracket inside the top of the enclosure on each side. Secure each bracket with 3 M5 nuts and torque to 2.3 N · m (20 in-lb). See *Illustration 1.1*.

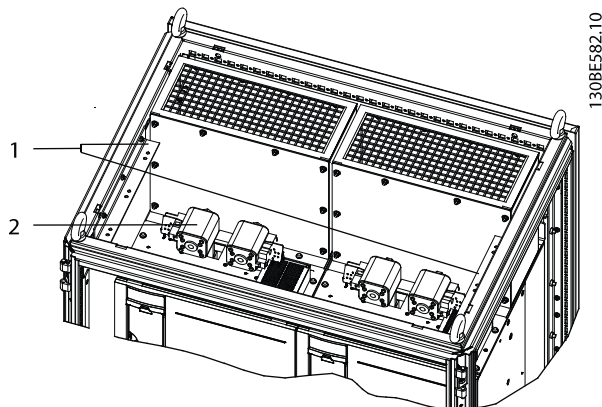

1	L-brackets	2	DC fuse with microswitch
---	------------	---	--------------------------

Illustration 1.1 Installation of DC Bus Bar L-brackets above the DC Fuses

2. Install the 6 stand-offs onto the support plate. Torque to 2.3 N · m (20 in-lb). Refer to *Illustration 1.2*.
3. Install the 2 DC-link bus bars onto the support plate using 3 M5 nuts per bus bar. Torque to 2.3 N · m (20 in-lb).
4. With the DC-link bus bars facing downward, slide the support plate onto the L-brackets. Secure the support plate with 6 M5 screws and torque to 2.3 N · m (20 in-lb). Refer to *Illustration 1.3*.

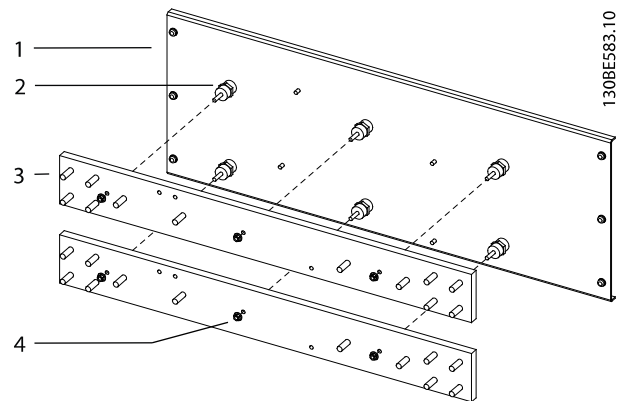

1	Support plate	3	DC-link bus bars
2	Stand-offs	4	M5 nut

Illustration 1.2 Installing DC-link Bus Bars onto Support Plate

5. Install the DC+ and DC- jumper bus bars between the DC fuses and the DC bus bars. Refer to *Illustration 1.4*.
6. Repeat this procedure to install DC-link bus bars into the 2nd cabinet.
7. To connect the DC-link bus bars in both cabinets, install the 2 cabinet-to-cabinet DC-link connectors. Refer to *Illustration 1.13*. Secure each DC-link connector with 4 M8 nuts and torque to 9.6 N · m (85 in-lb).

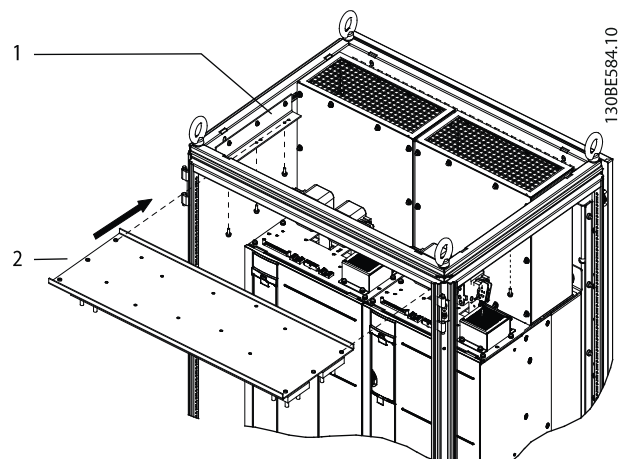

1	L-brackets
2	DC-link bus bar assembly (support plate and bus bars)

Illustration 1.3 Installation of DC Bus Bars onto L-brackets

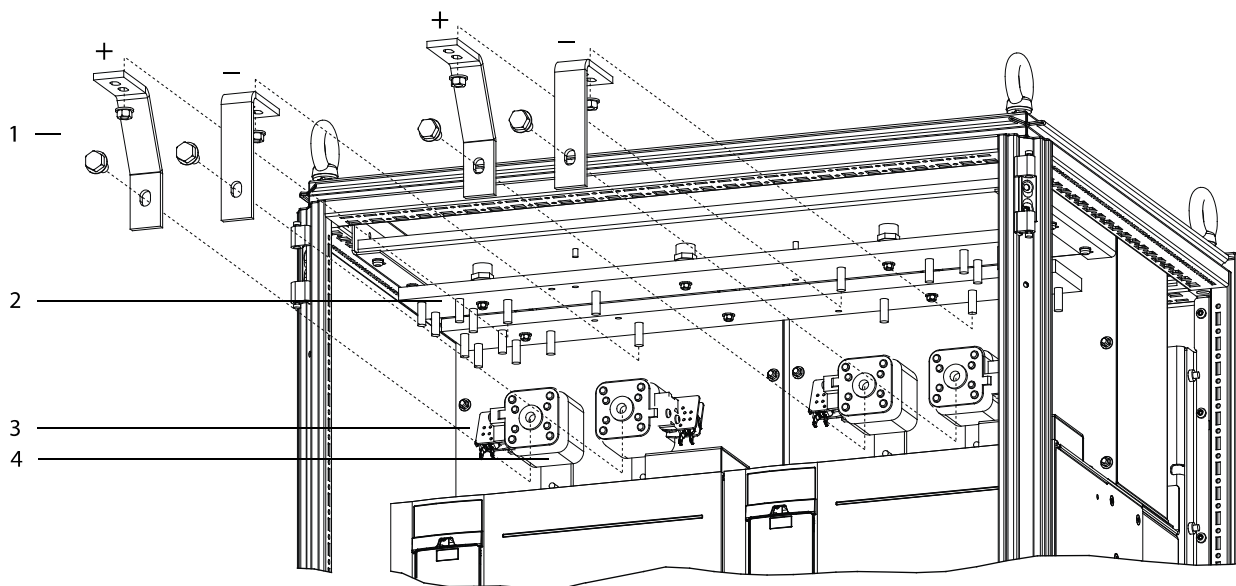

130BE585.10

1	DC-link jumper bus bars (+/- indicated in drawing)	3	Microswitch
2	DC-link bus bar	4	DC fuse

Illustration 1.4 Installation of DC Jumper Bus Bars

Assembling the AC Bus Bar Subassemblies

The AC bus bar assembly consists of the following 3 subassemblies, as shown in *Illustration 1.5*:

- Support subassembly consisting of 3 components
- Motor bus bar subassembly consisting of 3 components
- Mains bus bar subassembly consisting of 5 components

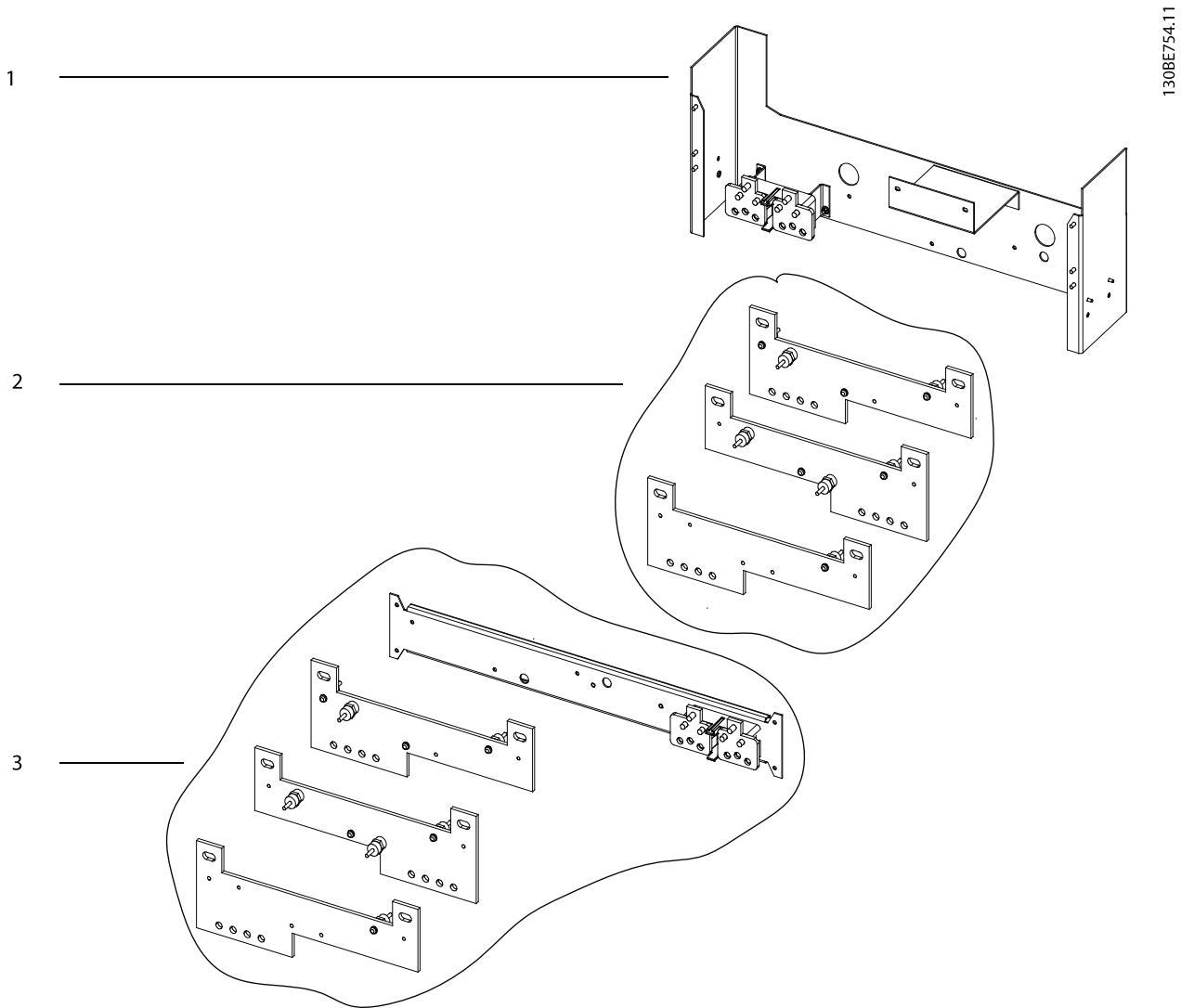

1	AC bus bar subassembly bracket	3	Mains bus bar subassembly
2	Motor bus bar subassembly	-	-

Illustration 1.5 Exploded View of the AC Bus Bar Assembly

1. Install the left and right brake terminals onto the brake terminal bracket using 4 M5 nuts. Torque to 2.3 N · m (20 in-lb).
2. Secure the brake terminal assembly to the AC bus bar assembly support with 2 M8 nuts. Torque to 9.6 N · m (85 in-lb). Refer to *Illustration 1.6*.
3. Install the mains bus bar S-bracket to the AC bus bar assembly support bracket using 2 M5 nuts. Torque to 2.3 N · m (20 in-lb).

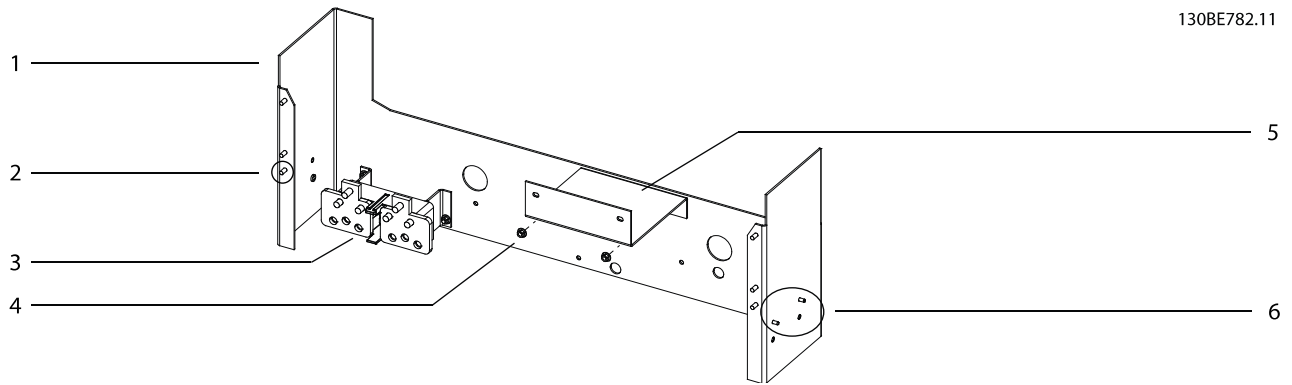

1	AC bus bar assembly support bracket	4	M5 nut
2	Mounting point for lower EMI/EMC shield	5	Mains bus bar S-bracket
3	Brake terminal assembly (terminals and bracket)	6	Studs that insert into the side support bracket

Illustration 1.6 Assembling the AC Bus Bar Subassembly Bracket

4. Assemble the motor bus bar subassembly using 9 stand-offs and 9 M5 nuts. Torque to 2.3 N · m (20 in-lb). Refer to *Illustration 1.7*.

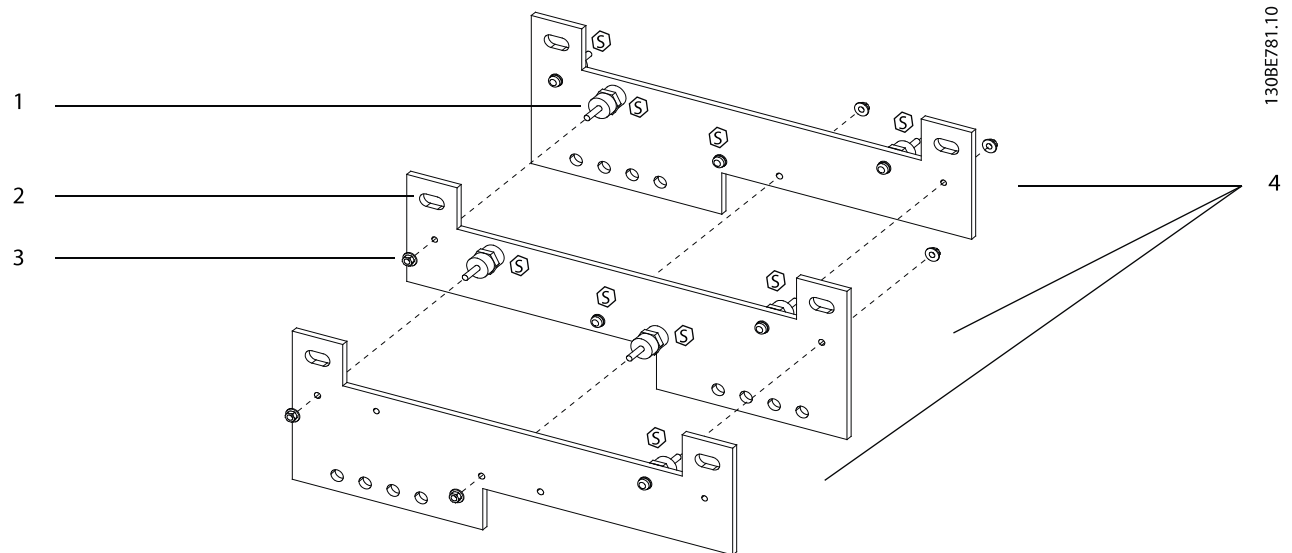

1	Slotted opening for M10 screw	3	M5 nut
2	Stand-offs (front and back side of bus bar), indicated by an S in the drawing	4	Solid motor bus bars

Illustration 1.7 Assembling the Motor Bus Bar Subassembly

5. Install the left and right brake terminals onto the brake terminal bracket using 4 M5 nuts. Torque to 2.3 N · m (20 in-lb).
6. Secure the brake terminal assembly to the mains bus bar support with 2 M8 nuts. Torque to 9.6 N · m (85 in-lb). Refer to *Illustration 1.6*.
7. Assemble the mains bus bar subassembly using 9 stand-offs and 9 M5 nuts. Torque to 2.3 N · m (20 in-lb). Refer to *Illustration 1.8*.

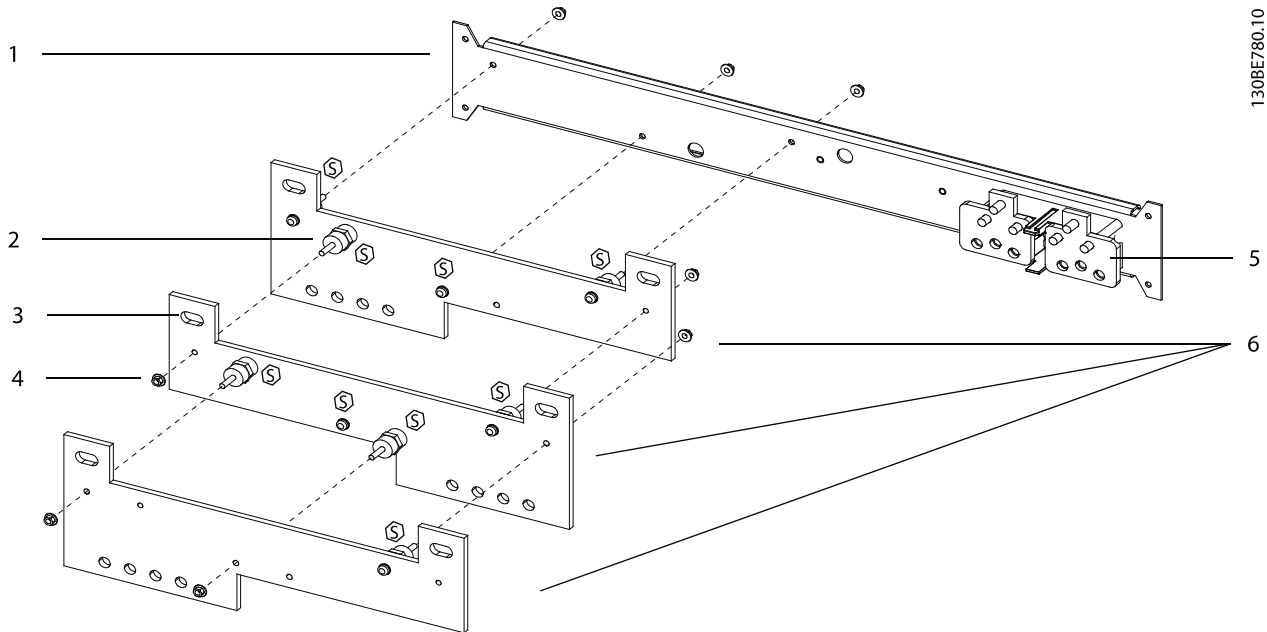

1	Mains bus bar support bracket	4	M5 nut
2	Stand-offs (front and back side of bus bar), indicated by an S in the drawing	5	Brake terminal assembly (terminals and bracket)
3	Slotted opening for M10 screw	6	Solid mains bus bars

Illustration 1.8 Assembling the Mains Bus Bar Subassembly

Installing the AC Bus Bar Assembly

1. Install 1 side support bracket inside the enclosure on each side. Secure each side support bracket with 4 M5 screws and torque to 2.3 N · m (20 in-lb). See *Illustration 1.9*.
2. Install ground plate assembly. See *Illustration 1.9*.
 - 2a Attach the ground support bracket to the inside of the enclosure. Secure with 4 M5 screws and torque to 2.3 N · m (20 in-lb).
 - 2b Install the ground plate onto the 5 studs on the ground support bar.
 - 2c Secure the bottom of the ground plate to the enclosure using 8 M5 screws. Torque to 2.3 N · m (20 in-lb).
 - 2d Install the ground bus bar onto the ground plate. Secure with 5 M8 nuts and torque to 9.6 N · m (85 in-lb).
 - 2e Install the 1 ground jumper plate per drive module. Secure the bottom of the ground jumper plate to the top of the ground plate using 1 M5 nut. Torque to 2.3 N · m (20 in-lb).
 - 2f Secure the top of the ground jumper plate to the bottom of the drive module reusing the 2 existing M10 nuts. Torque to 19 N · m (169 in-lb).
3. Install the ground jumper bus bars. Perform this step for each drive module.
 - 3a Secure the bottom of the ground jumper bus bar to the ground bus bar using 1 M5 nut. Torque to 2.3 N · m (20 in-lb). See *Illustration 1.9* for the mounting attachment points on the ground bus bar.
 - 3b Secure the other end of the ground jumper bus bar to the drive module ground terminal using 1 M5 nut. Torque to 2.3 N · m (20 in-lb).
4. Secure the motor bus bar subassembly (see *Illustration 1.7*) to the AC bus bar assembly bracket (*Illustration 1.6*) using 3 M5 nuts. Torque to 2.3 N · m (20 in-lb).
5. Install the AC bus bar bracket/motor bus bar subassembly to the side support brackets. Secure each side with 2 M5 nuts and torque to 2.3 N · m (20 in-lb).
6. Shape the flexible bus bars to fit.
7. Install the motor flexible bus bars for each drive module. Refer to *Illustration 1.10*.
 - 7a Insert 1 M10 screw into each of the slotted holes in the motor bus bar subassembly, with the screw shaft facing the front.
 - 7b Install 3 flexible motor bus bars per drive module, securing 1 end to the screw and the other end to the drive module terminal. Secure with 2 M10 nuts per bus bar. Torque to 19 N · m (169 in-lb).
 - 7c Verify that the proper U, V, W connections are made. Refer to the *Terminal Dimensions* section in the *VLT® Parallel Drive Modules Installation Guide*.
 - 7d Assemble the front EMI/EMC bracket assembly.
 - a. Attach the left EMI/EMC bracket to the front EMI/EMC bracket using 3 M5 screws. Torque to 2.3 N · m (20 in-lb).
 - b. Attach the right EMI/EMC bracket to the front EMI/EMC bracket using 3 M5 screws. Torque to 2.3 N · m (20 in-lb).
8. Install the front EMI/EMC bracket assembly over each set of flexible motor bus bars. Secure with 4 M5 nuts and torque to 2.3 N · m (20 in-lb). Refer to *Illustration 1.11*.
9. Fasten the mains bus bar subassembly (see *Illustration 1.8*) to the motor bus bar subassembly using 4 M5 nuts. Torque to 2.3 N · m (20 in-lb).
10. Install the flexible mains bus bars for each drive module. Refer to *Illustration 1.12*.
 - 10a Insert 1 M10 screw into each of the slotted holes in the mains bus bar subassembly, with the screw shaft facing the front.
 - 10b Install 3 flexible mains bus bars per drive module, securing 1 end to the screw and the other end to the drive module mains terminal. Secure with 2 M10 nuts per bus bar. Torque to 19 N · m (169 in-lb).
 - 10c Verify the proper R, S, T connections are made. Refer to the *Terminal Dimensions* section in the *VLT® Parallel Drive Modules Installation Guide*.
11. Install the lower EMI/EMC shield to the AC bus bar subassembly bracket. Secure with 2 M5 nuts. Torque to 2.3 N · m (20 in-lb). See *Illustration 1.13*.
12. Repeat this procedure for installing the AC bus bar assembly for the 2nd cabinet.

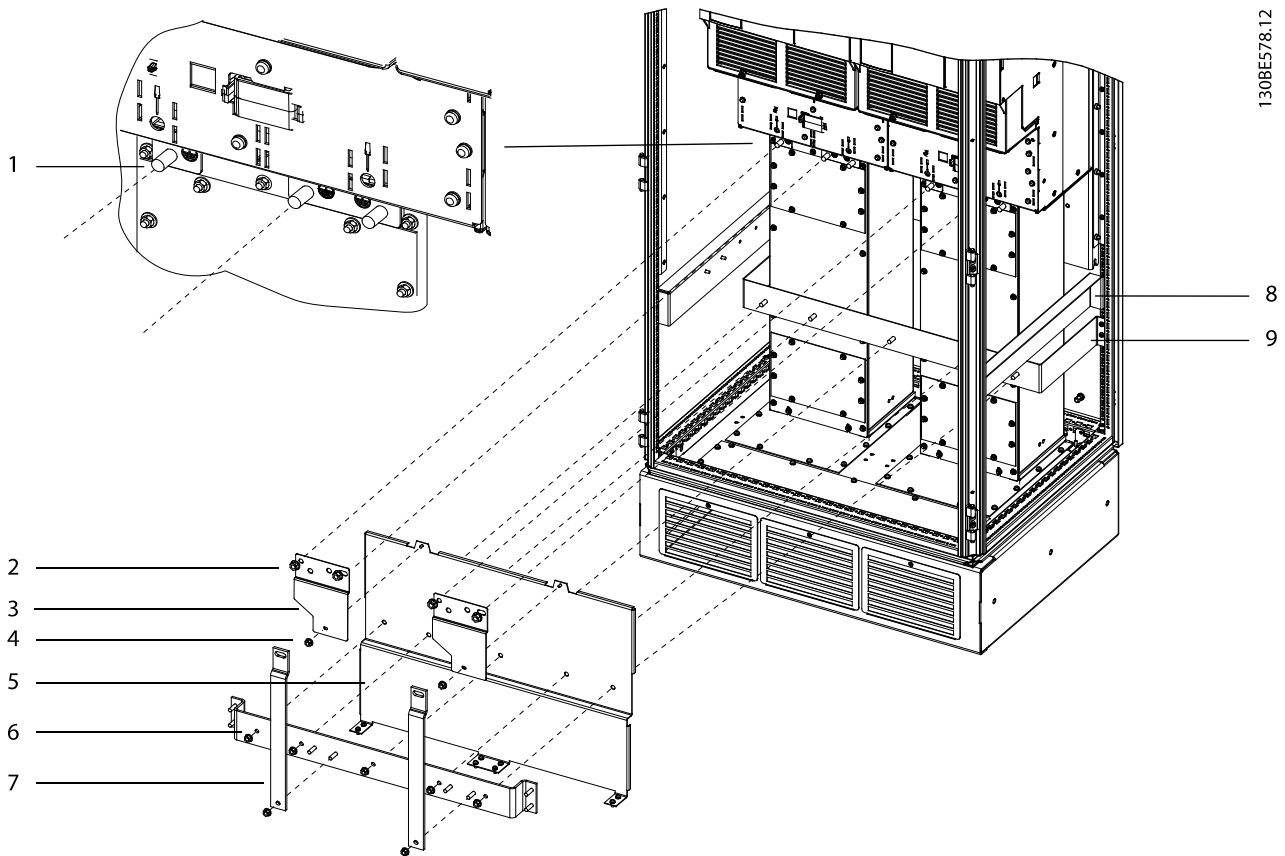

1	Screw at the bottom of the drive module that connects to the top of the ground jumper plate	6	Ground bus bar
2	M10 nut	7	Ground jumper bus bar
3	Ground jumper plate	8	Side support bracket
4	M5 nut	9	Ground support bracket
5	Ground plate	-	-

Illustration 1.9 Installation of Side Support Brackets and Ground Bus Bar Assembly

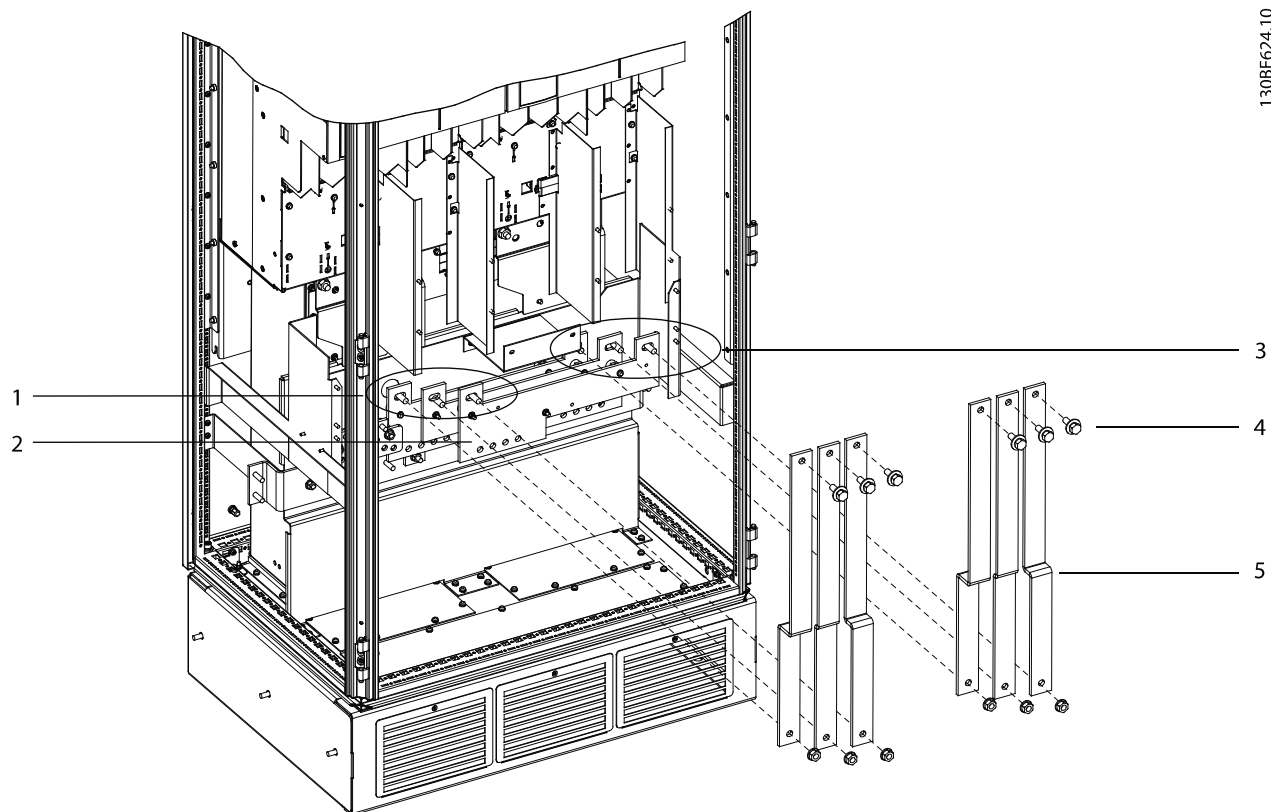

1	Motor bus bar screws for drive module 1	4	M10 nuts
2	Motor bus bar subassembly	5	Flexible motor bus bars
3	Motor bus bar screws for drive module 2	-	-

Illustration 1.10 Installation of Flexible Motor Bus Bars

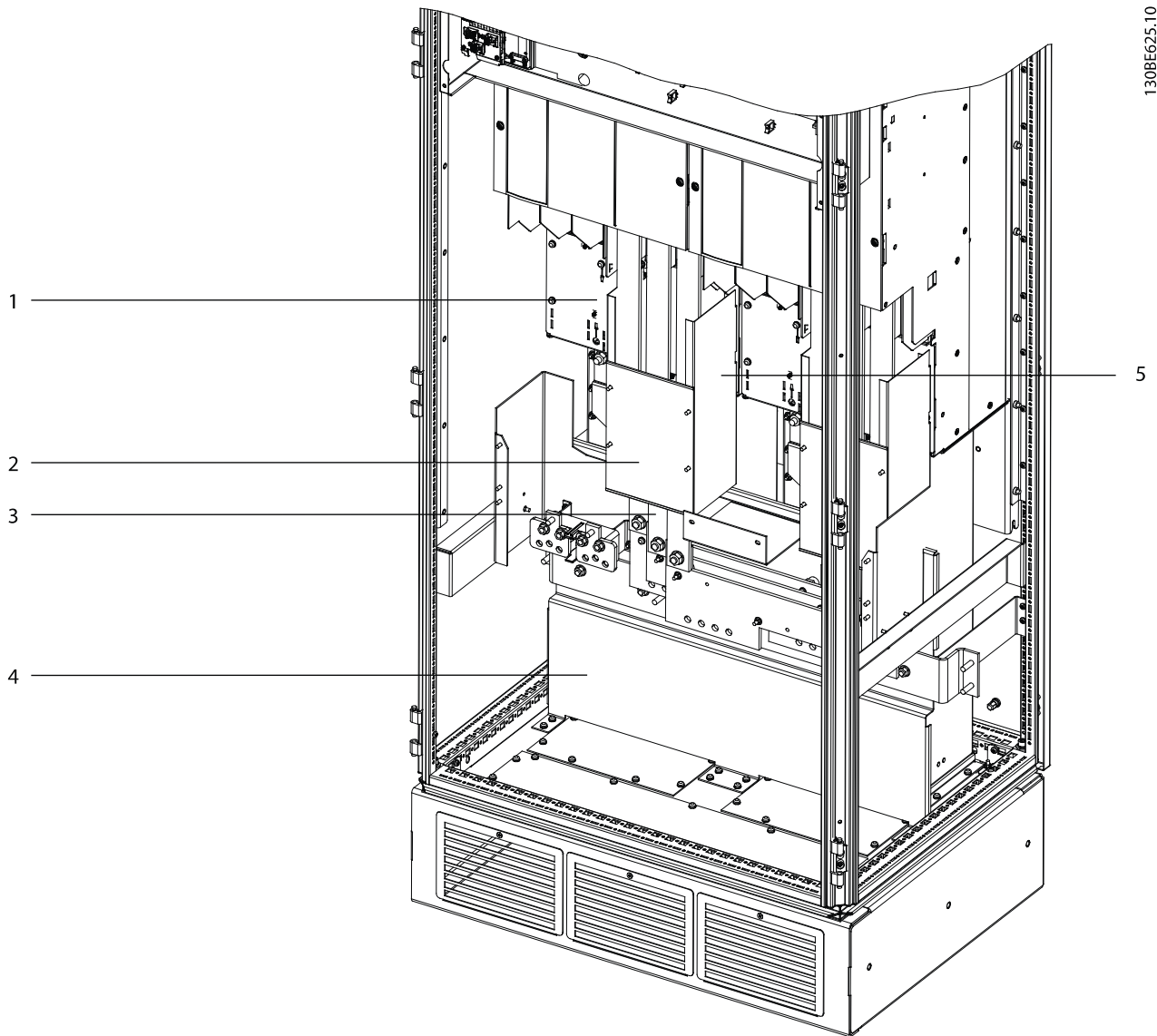

1308E625.10

1	Left EMI/EMC bracket (shown on drive module 1)	4	Ground plate
2	Front EMI/EMC bracket (shown on drive module 1)	5	Right EMI/EMC bracket (shown on drive module 1)
3	Flexible motor bus bars	-	-

Illustration 1.11 Installation of Front EMI/EMC Bracket Assembly

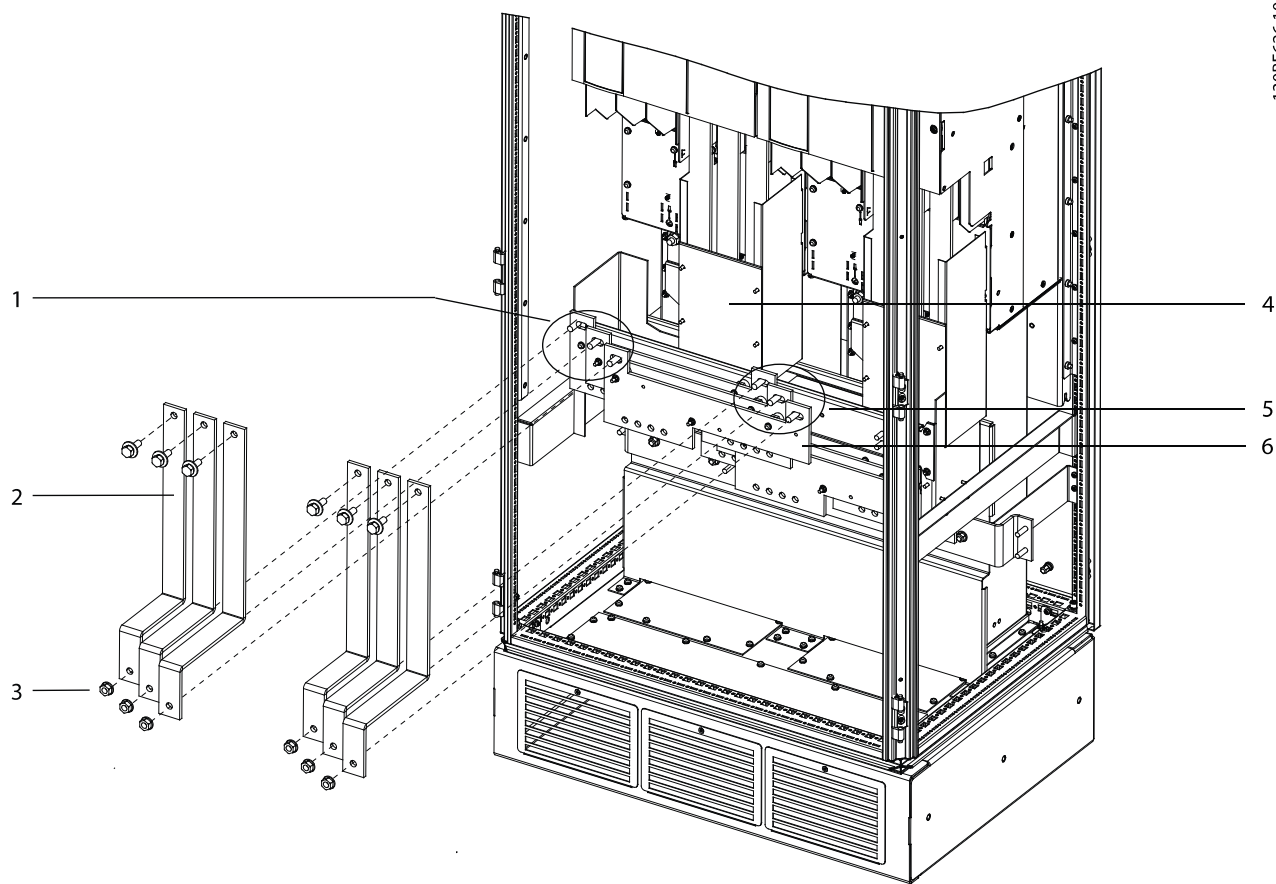

1	Mains bus bar screws for drive module 1	4	Front EMI/EMC bracket assembly
2	Flexible mains bus bars	5	Mains bus bar screws for drive module 2
3	M10 nuts	6	Mains bus bar subassembly

Illustration 1.12 Installation of Flexible Mains Bus Bars and Lower EMI/EMC Shield

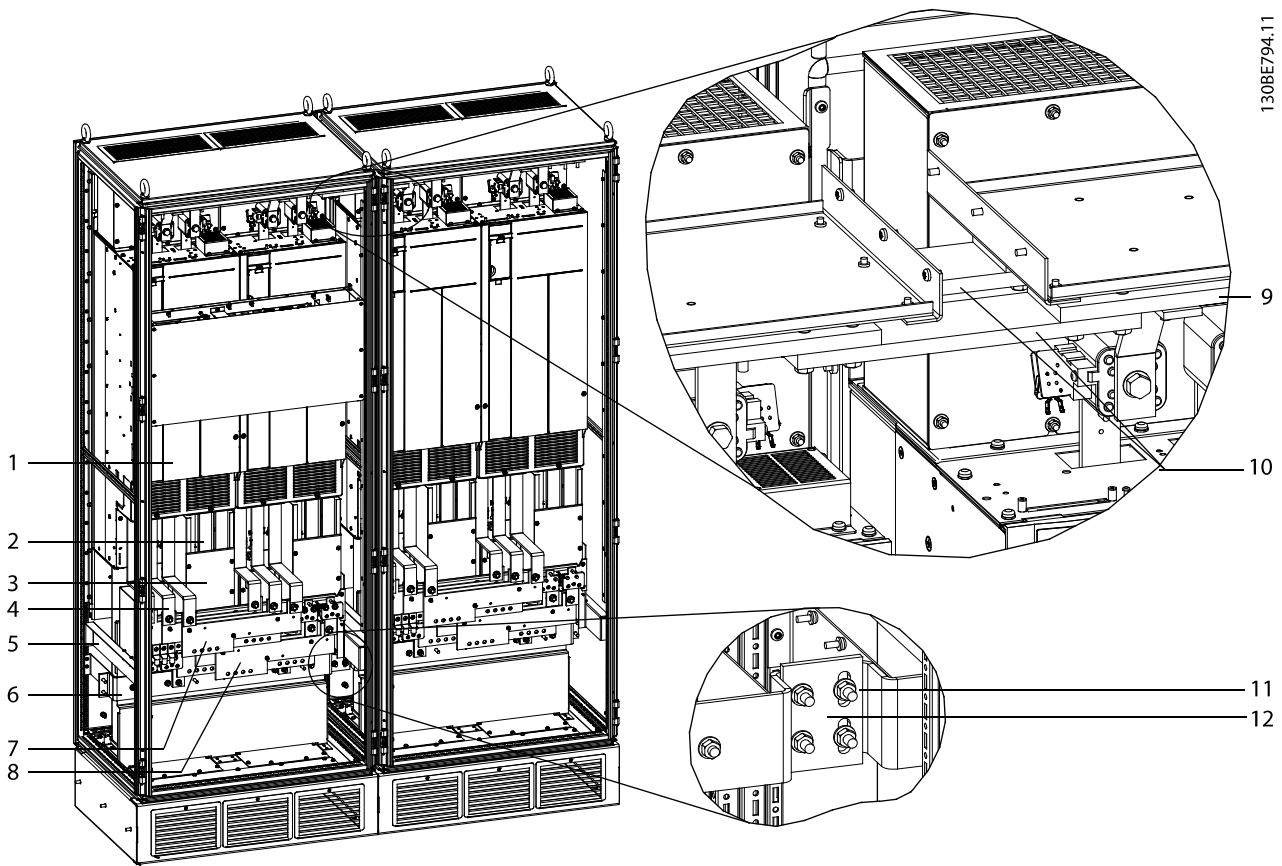

1	Drive module 1	7	Solid mains bus bar
2	Flexible motor bus bars for drive module 1	8	Solid motor bus bar
3	Front EMI/EMC bracket assembly (shown on module 1)	9	DC-link bus bar
4	Flexible mains bus bars for drive module 1	10	Cabinet-to-cabinet DC-link connectors
5	Side support bracket	11	M8 nut
6	Ground bus bar	12	Cabinet-to-cabinet ground connector

Illustration 1.13 Completed Bus Bar Assembly on a 4-drive System

.....
 Danfoss can accept no responsibility for possible errors in catalogues, brochures and other printed material. Danfoss reserves the right to alter its products without notice. This also applies to products already on order provided that such alterations can be made without subsequential changes being necessary in specifications already agreed. All trademarks in this material are property of the respective companies. Danfoss and the Danfoss logotype are trademarks of Danfoss A/S. All rights reserved.

Danfoss A/S
 Ulsnaes 1
 DK-6300 Graasten
 vlt-drives.danfoss.com

