

Installation Instructions

500 A Current Sensor Kit for F1–F4/F8–F13 Enclosure Sizes

VLT[®] Series FC 102, FC 202, and FC 302

1.1 Description

The 500 A current sensor kit is designed for F1–F4 and F8–F13 enclosure sizes in the power ranges shown in *Table 1.1*. To identify the power rating, see *Illustration 1.1*.

Product group and series	Voltage rating	Power rating
VLT [®] HVAC Drive FC 102 and VLT [®] AQUA Drive FC 202	(T4) 380–480 V	315–1000 kW (450–1350 hp)
	(T7) 525–690 V	450–1400 kW (450–1550 hp)
VLT [®] AutomationDrive FC 302	(T5) 380–500 V	250–800 kW (350–1200 hp)
	(T7) 525–690 V	355–1200 kW (400–1350 hp)

Table 1.1 Applicable Power Range for 500 A Current Sensor Kit

This 500 A current sensor kit contains all components required to upgrade the current sensors in F1–F4 and F8–F13 enclosure sizes.

1.1.1 Identifying the Power Rating

To find the frequency converter power rating, use the following steps:

1. Obtain the following information from the nameplate, which is on the frequency converter. Refer to *Illustration 1.1*.
 - 1a Product group and product series (characters 1–6)
 - 1b Power rating (characters 7–10)
 - 1c Voltage rating (phases and mains) (characters 11–12)
2. Check that the power rating is in *Table 1.1*.

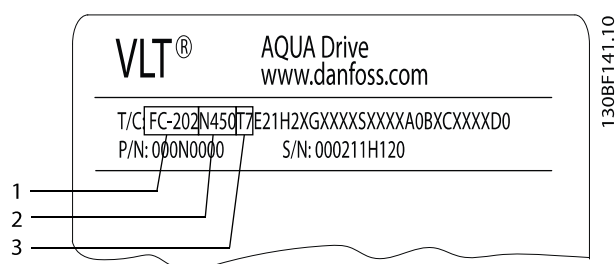

1	Product group and product series
2	Power rating
3	Voltage rating (phases and mains)

Illustration 1.1 Nameplate for a VLT[®] AQUA Drive FC 202

1.2 Kit Part Number

Part number	Kit description
176F3747	Current sensor kit for F1–F4/F8–F13 enclosures

Table 1.2 Part Number for the Current Sensor Kit

1.2.1 Items Supplied

The 500 A current sensor kit for F1–F4 and F8–F13 enclosure sizes contains the following parts.

Quantity	Item description
3	500 A current sensors
3	Busbars
1	Wire harness
3	Cable ties
6	Hex nuts (M4) and washers

Table 1.3 500 A Current Sensor Kit Parts List

1.3 Safety Instructions

CAUTION

TRAINING REQUIRED

Only certified technicians trained by Danfoss are allowed to replace the parts described in these installation instructions. Installation work done by non-qualified personnel can result in personal injury or equipment damage. Make sure to read and save these instructions.

WARNING

ELECTRICAL SHOCK HAZARD

VLT® frequency converters contain dangerous voltages when connected to mains voltage. Improper installation, and installing or servicing with power connected, can cause death, serious injury, or equipment failure.

To avoid death, serious injury, or equipment failure:

- Only use qualified electricians for the installation.
- Disconnect the frequency converter from all power sources before installation or service.
- Treat the frequency converter as live whenever the mains voltage is connected.
- Follow the guidelines in these instructions and local electrical safety codes.

WARNING

DISCHARGE TIME

The frequency converter contains DC-link capacitors, which can remain charged even when the unit is off. High voltage can be present even when the warning indicator lights are off. Failure to wait a minimum of 20 minutes after power is removed before performing service work can result in death or serious injury.

1. Stop the motor.
2. Disconnect AC mains and remote DC-link supplies, including battery back-ups, UPS, and DC-link connections to other frequency converters.
3. Disconnect or lock PM motor.
4. Wait 20 minutes for the capacitors to discharge.
5. To verify full discharge, measure the voltage level.

1.4 Disassembly Guidelines

NOTICE

The current sensor kit includes an extra set of fasteners in case any fasteners are missing or unusable. To make the disassembly/reassembly process easier, use these general guidelines:

1. Follow the disassembly instructions for each component.
2. Keep the component together with the removed fasteners.
3. Replace the old components with the new components provided in the kit.
4. If any fasteners are stripped or lost, replace with similar fastener from the kit.
5. Follow the installation instructions for replacing and securing each component.

1.4.1 Removing the Cover Plate

To remove the cover plate from the inverter module, use the following procedure. Refer to *Illustration 1.2*.

1. Remove the inverter module from the frequency converter. Refer to the *installation guide*.
2. Remove 4 nuts (M6), 1 from each corner of the cover plate.
3. Lift the cover plate from the module.

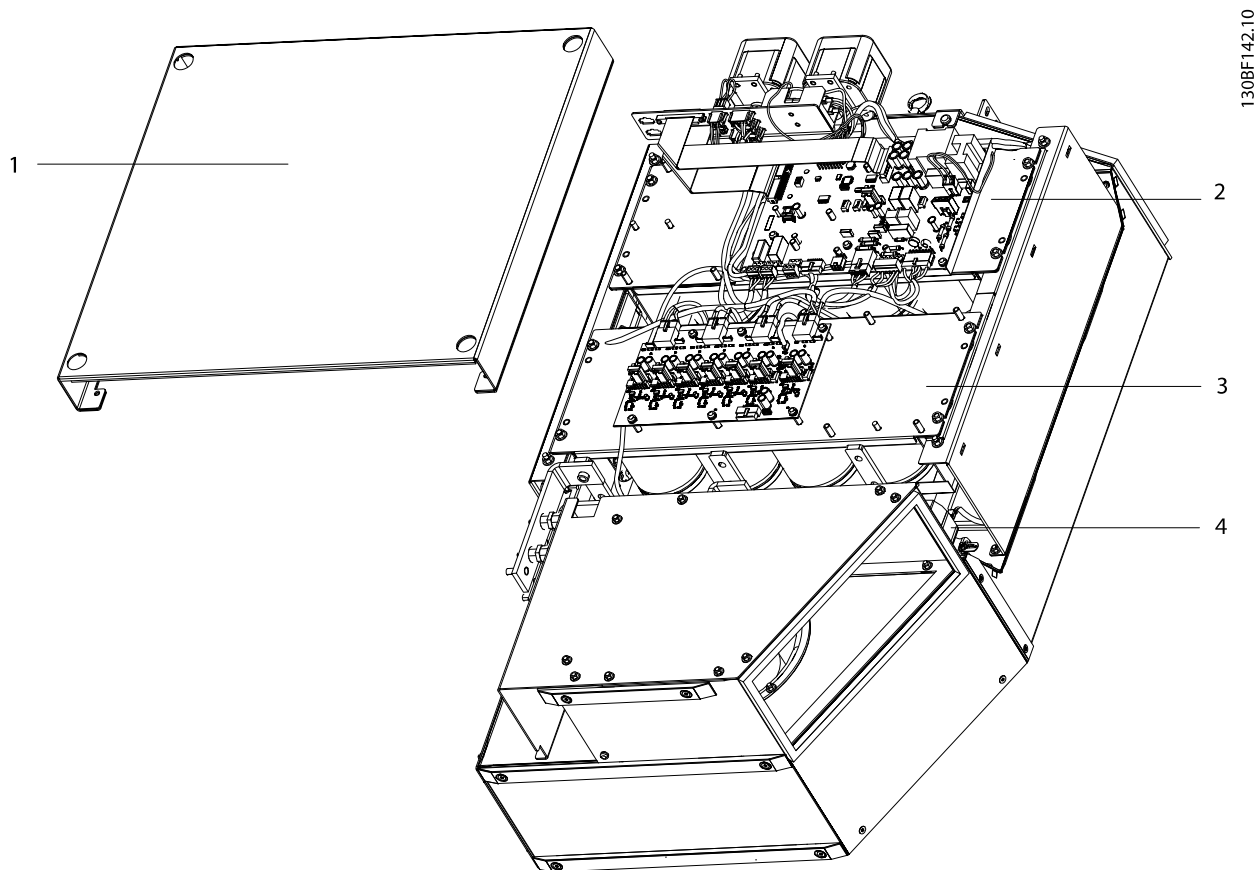

1	Cover plate	3	Lower capacitor bank assembly
2	Upper capacitor bank assembly	4	Current sensor

Illustration 1.2 Inverter Module

1.4.2 Removing the Lower Capacitor Bank

Remove the lower capacitor bank assembly using the following procedure. Refer to *Illustration 1.3*.

NOTICE

CAPACITOR ASSEMBLY WEIGHT

The lower capacitor bank weighs approximately 9 kg (20 lb).

- | | |
|--|--|
| <ol style="list-style-type: none"> 1. Disconnect the cables from the following gatedrive card connectors: <ul style="list-style-type: none"> 1a MK100 1b MK102 | <ol style="list-style-type: none"> 1c MK103 1d MK104 1e MK106 1f MK105 (if the unit has a brake option) <ol style="list-style-type: none"> 2. Remove the 6 recessed connection nuts (M5) that secure the capacitor bank assembly. These nuts are found in the gap between the upper and lower capacitor banks. 3. Remove the 4 retaining nuts (M6) securing the lower capacitor bank assembly. The gatedrive card can remain in place on the assembly. 4. Lift the capacitor bank assembly from the unit. |
|--|--|

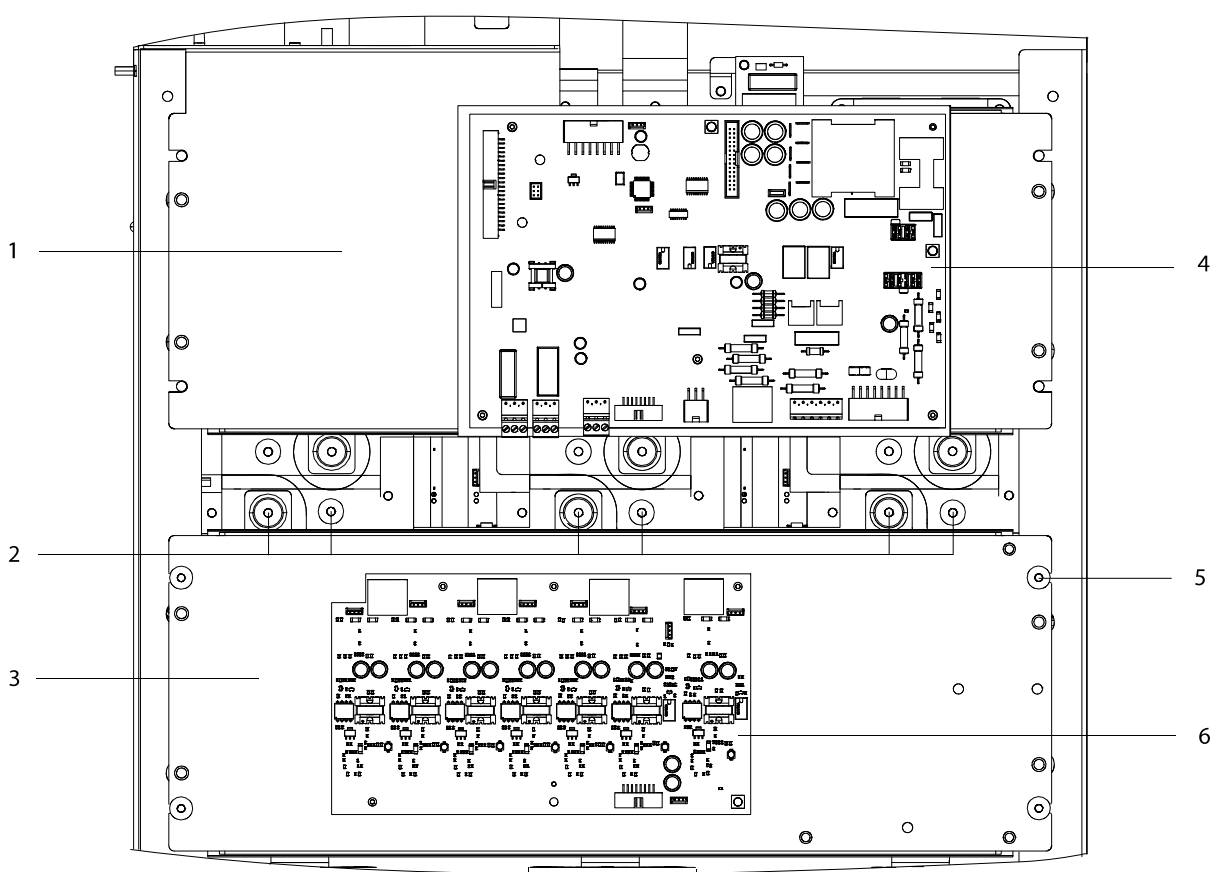

130BF143.10

1	Upper capacitor bank assembly	4	Power card
2	Recessed connection nuts (M5)	5	Retaining nut (M6)
3	Lower capacitor bank assembly	6	Gatedrive card

Illustration 1.3 Capacitor Bank Assembly, F1-F2

1.4.3 Removing the Current Sensor Wire Harness

Remove the current sensor wire harness using the following procedure. Refer to *Illustration 1.4*.

1. Unplug the 16-pin cable from the MK102 connector on the power card.
2. Remove the screw (M5) attaching the ring terminal ground to the power card.
3. Detach the cable from the 3-pin connector on the high frequency card.
4. Detach the wire from each current sensor.
5. Detach any cable ties that secure the wire harness in the unit.
6. Lift the wire harness from the unit.

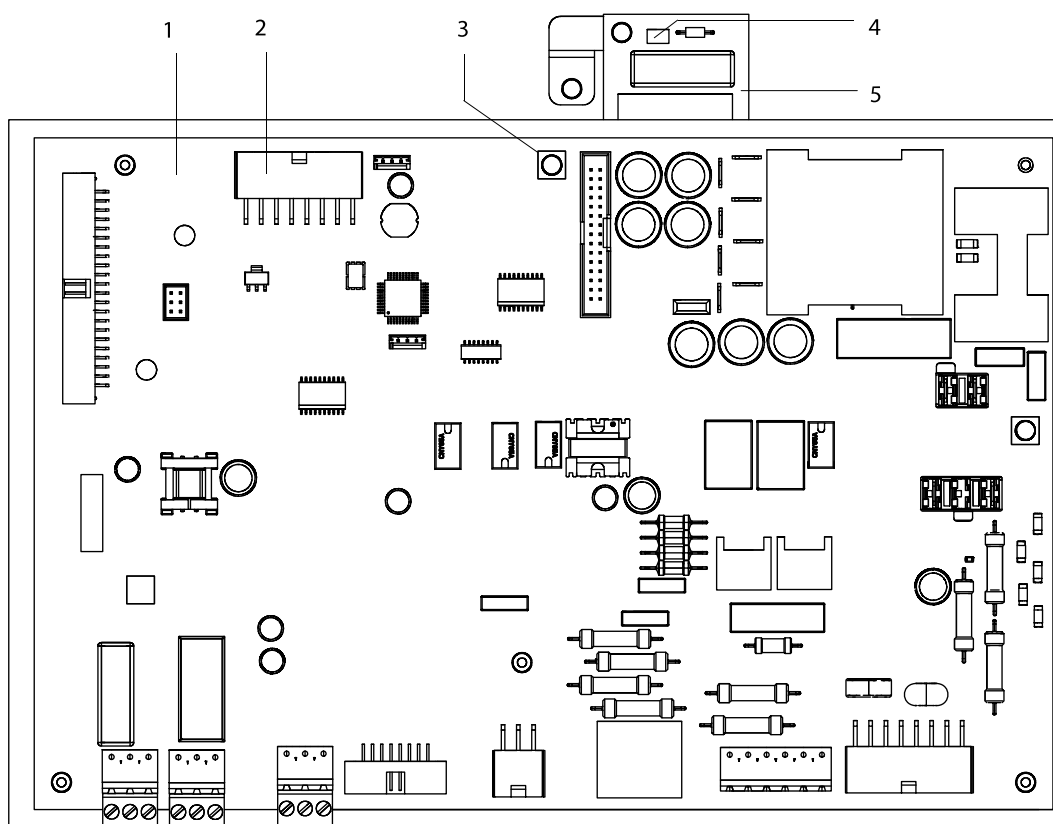

1308F201.10

1	Power card	4	3-pin connector
2	16-pin cable connector (MK102)	5	High frequency card
3	Ring terminal ground (M5)	-	-

Illustration 1.4 Power Card

1.4.4 Removing the Current Sensors with Busbars

To remove each current sensor and its busbar, use the following procedure. Refer to *Illustration 1.5*.

1. Remove 6 screws (M6) connecting the busbar to the IGBT module at the IGBT end of the busbar.
2. Remove 3 standoff nuts (M4) from the IGBT end of the busbar.
3. Remove 1 screw (M8) from the opposite end of the busbar where it connects to the output busbar.
4. Remove 2 nuts (M4) that attach the base of the current sensor to the back panel.
5. Remove the busbar and current sensor.

NOTICE

Retain the nuts and screws for reassembly of the current sensor and busbars.

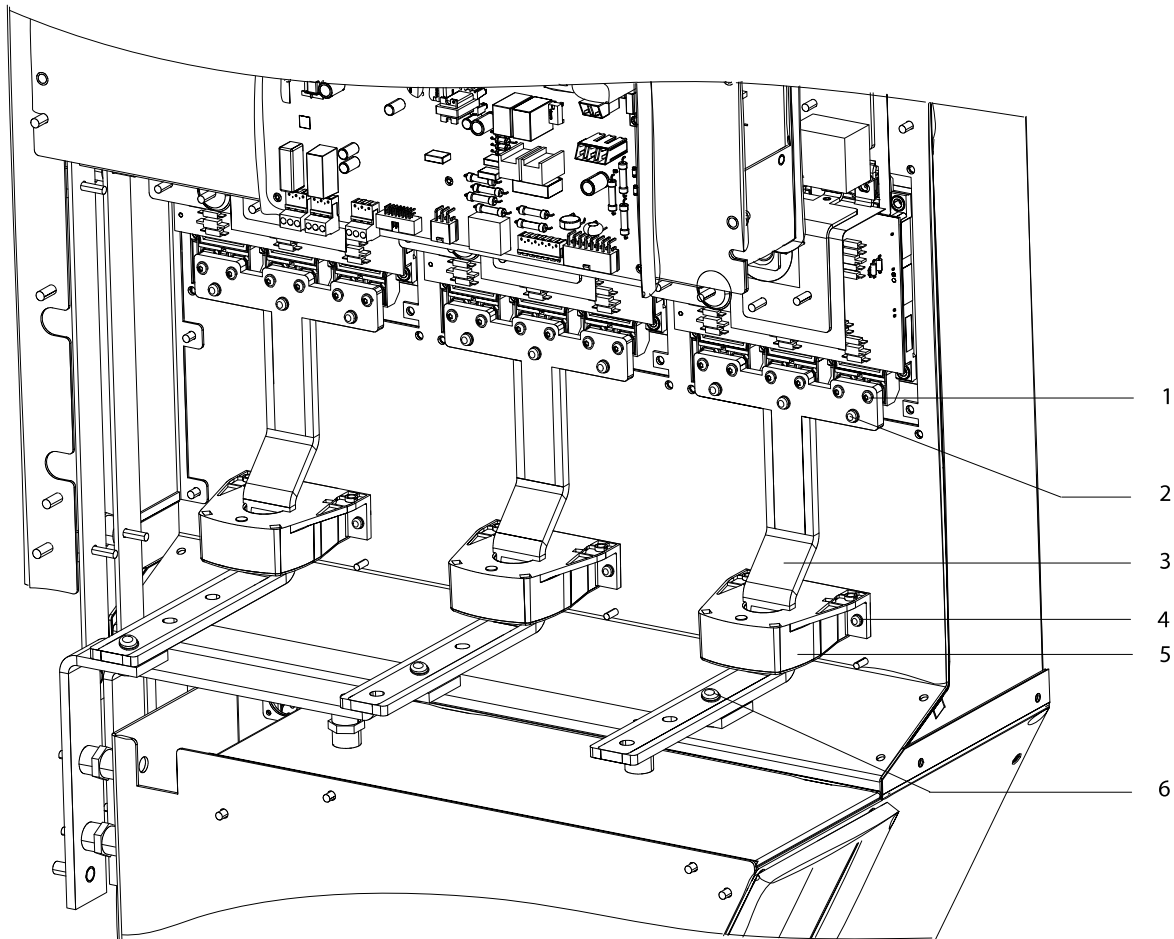

130BF200.10

1	Screw (M6)	4	Nut (M4)
2	Standoff nut (M4)	5	Current sensor
3	Busbar	6	Nut (M8)

Illustration 1.5 Current Sensor Assembly

1.5 Reassembly Guidelines

1.5.1 Installing the Current Sensor Wire Harness

Install the new current sensor wire harness using the following procedure. Refer to *Illustration 1.6*.

1. Plug the 16-pin cable into the MK102 connector on the power card.
2. Secure the screw (M5) attaching the ring terminal ground to the power card.
3. Attach the cable to the 3-pin connector on the high frequency card.
4. Attach cable ties securing the wire harness in the unit.

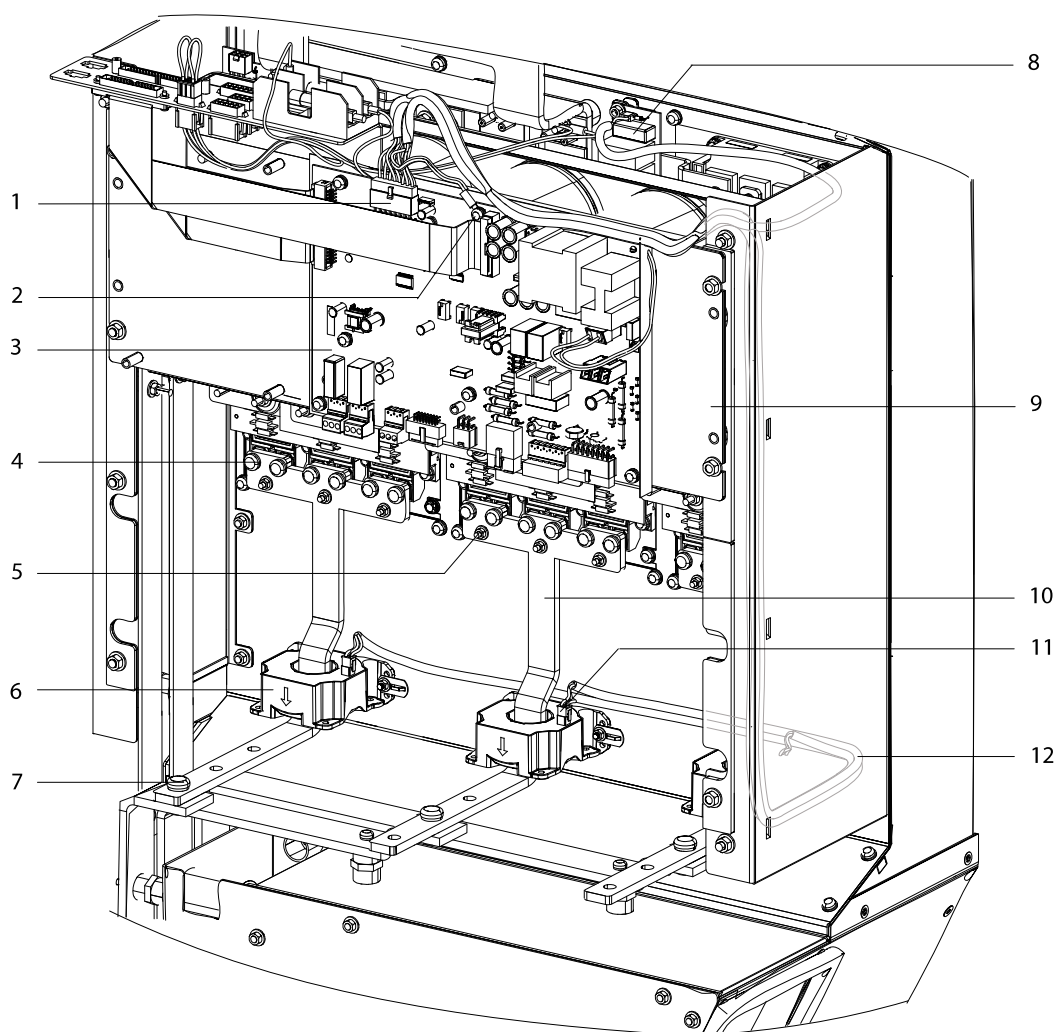

1	16-pin cable connector (MK102)	7	Nut (M8)
2	M5 ring terminal ground	8	3-pin connector on high frequency card
3	Power card	9	Upper capacitor bank assembly
4	Screw (M6)	10	Busbar
5	Nut (M4)	11	Current sensor cable connector
6	Current sensor	12	Current sensor wire harness

Illustration 1.6 300 A Current Sensors, Busbars, and Wire Harness

1.5.2 Installing the Current Sensors with Busbars

To install the 3 current sensors and their busbars, use the following procedure. Refer to *Illustration 1.6*.

1. Slide the new current sensor onto the new busbar and place it in the unit. Position the sensor with the arrow on the sensor facing away from the IGBTs. See *Illustration 1.6*.
2. Secure the current sensor base to the back panel using 2 nuts (M4).
3. Reconnect the wire harness to the current sensor.
4. Secure the output busbar to the current sensor busbar using 1 screw (M8).
5. Attach the IGBT end of the busbar to the 3 standoffs using 3 nuts (M4).
6. Secure the IGBT end of the busbar to the IGBT module using 6 screws (M6).
7. Repeat steps 1–6 for each current sensor.

1.5.3 Installing the Lower Capacitor Bank

Reinstall the lower capacitor bank assembly using the following procedure. Refer to *Illustration 1.3*.

NOTICE

CAPACITOR ASSEMBLY WEIGHT

The lower capacitor bank weighs approximately 9 kg (20 lb).

1. Place the lower capacitor bank assembly in its original position.
2. Secure the capacitor bank assembly using 4 retaining nuts (M6).
3. Secure the capacitor bank using 6 recessed connection nuts (M5).
4. Connect the cables to the following connectors on the gatedrive card:
 - 4a MK100
 - 4b MK102
 - 4c MK103
 - 4d MK104
 - 4e MK106
 - 4f MK105 (if the unit has a brake option)

.....
Danfoss can accept no responsibility for possible errors in catalogues, brochures and other printed material. Danfoss reserves the right to alter its products without notice. This also applies to products already on order provided that such alterations can be made without subsequential changes being necessary in specifications already agreed. All trademarks in this material are property of the respective companies. Danfoss and the Danfoss logotype are trademarks of Danfoss A/S. All rights reserved.
.....

