

Installation Instructions

MDCIC Spare Part Kit for F1–F4/F10–F13 Enclosure Sizes

1.1 Description

The MDCIC spare part kit contains all components required to replace the multi-drive control interface card (MDCIC) in F1–F4 and F10–F13 enclosure sizes.

1.2 Kit Part Number

Part number	Kit description
176F8773	MDCIC spare part kit for F1–F4/F10–F13

Table 1.1 Part Number

1.2.1 Items Supplied

Quantity	Description
1	Multi-drive control interface card
1	Jumper cable (178N0167)

Table 1.2 Parts List

1.3 Safety Instructions

1.3.1 Qualified Personnel

Correct and reliable transport, storage, installation, operation, and maintenance are required for the trouble-free and safe operation of the frequency converter. Only qualified personnel are allowed to install or operate this equipment.

Qualified personnel are defined as trained staff, who are authorized to install, commission, and maintain equipment, systems, and circuits in accordance with pertinent laws and regulations. Also, the qualified personnel must be familiar with the instructions and safety measures described in this installation guide.

⚠ WARNING

ELECTRICAL SHOCK HAZARD

VLT® frequency converters contain dangerous voltages when connected to mains voltage. Improper installation, and installing or servicing with power connected, can cause death, serious injury, or equipment failure.

To avoid death, serious injury, or equipment failure:

- Only use qualified electricians for the installation.
- Disconnect the frequency converter from all power sources before installation or service.
- Treat the frequency converter as live whenever the mains voltage is connected.
- Follow the guidelines in these instructions and local electrical safety codes.

⚠ WARNING

DISCHARGE TIME

The frequency converter contains DC-link capacitors that can remain charged even when the unit is off. High voltage can be present even when the warning indicator lights are off. Failure to wait a minimum of 40 minutes after power is removed before performing service work can result in death or serious injury.

1. Stop the motor.
2. Disconnect AC mains and remote DC-link supplies, including battery back-ups, UPS, and DC-link connections to other frequency converters.
3. Disconnect or lock PM motor.
4. Wait 40 minutes for the capacitors to discharge.
5. To verify full discharge, measure the voltage level.

1.4 Disassembly Guidelines

NOTICE

PARTS REUSE

Retain all fasteners and parts, except the old MDCIC, for reuse during installation. Replacement scaling cards are not included with the new MDCIC. Retain the scaling cards for reinstallation on the new MDCIC.

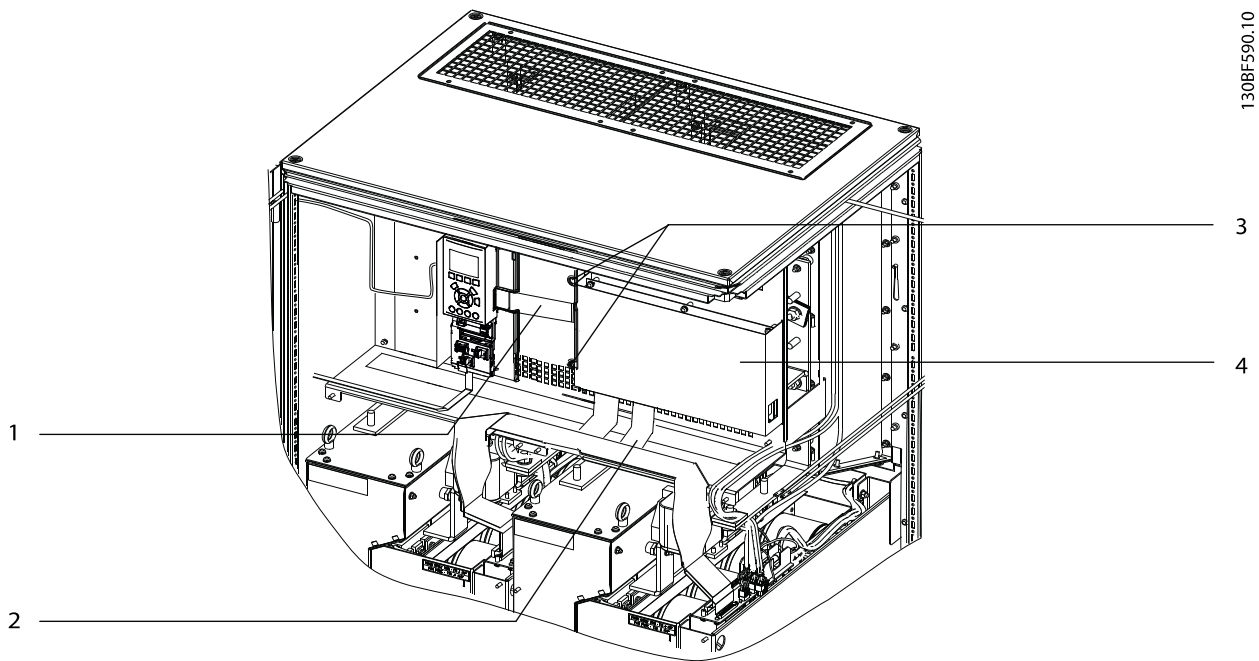

1	Control card ribbon cable	3	Retaining screw
2	Inverter module ribbon cables	4	MDCIC cover

Illustration 1.1 MDCIC Mounting Panel and Cables

1.4.1 Identifying the MDCIC Issue Number

Use these steps to find the issue number of the multi-drive control interface card (MDCIC) before removal. The issue number indicates whether to install the jumper cable included with this kit.

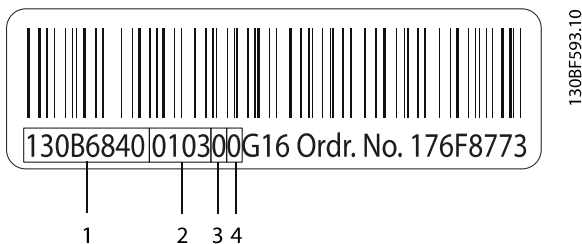

1	MDCIC assembly number	3	MDCIC issue number
2	MDCIC serial number	4	MDCIC revision number

Illustration 1.2 MDCIC Barcode Label

1. Detach 2 screws from the MDCIC cover and remove the cover. See *Illustration 1.1*.
2. Review the following information on the MDCIC barcode label. See *Illustration 1.2*.
 - 2a Assembly number (characters 1–8).
 - 2b Serial number (characters 9–12).
 - 2c Issue number (character 13).
 - 2d Revision number (character 14).
3. Note the MDCIC issue number (character 13).
 - 3a If this character is 1–5, connect the jumper cable provided with this kit to MK111 on the new MDCIC. See *Illustration 1.3* and *Illustration 1.5*.
 - 3b If this character is 0, disconnect the Safe Torque Off (STO) cable from MK111 on the old MDCIC and retain it.

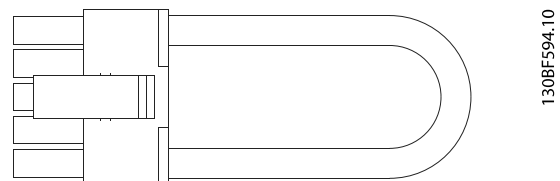
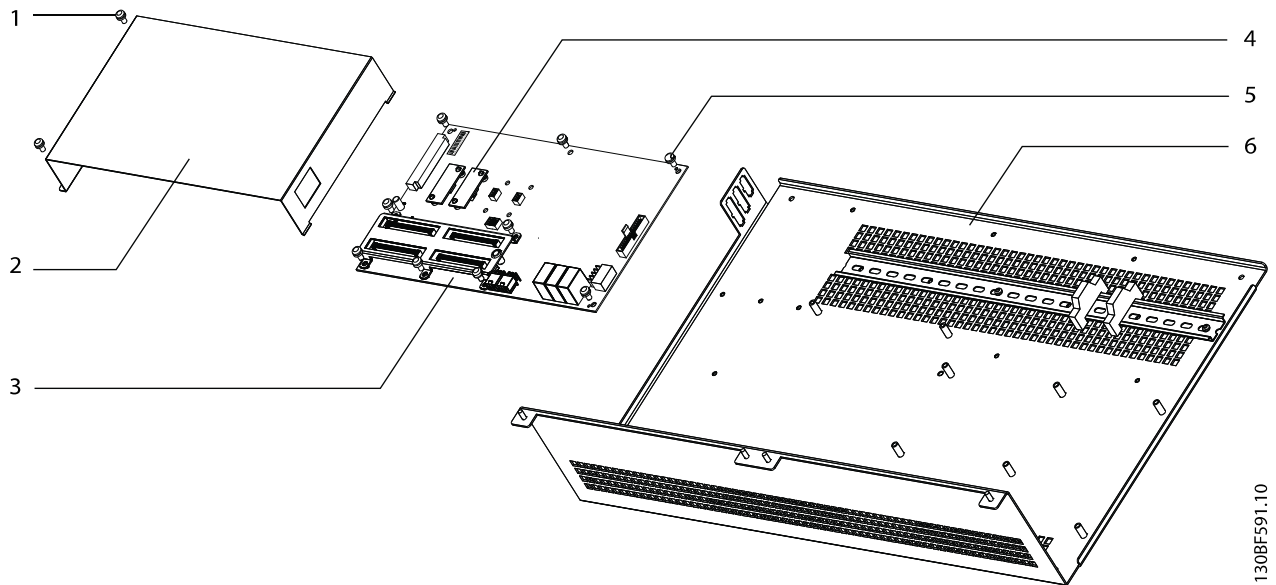

Illustration 1.3 Jumper Cable (178N0167)



1	Cover screw	4	Scaling card
2	MDCIC cover	5	MDCIC screw
3	MDCIC	6	MDCIC mounting panel

Illustration 1.4 Exploded View of MDCIC Mounting Panel

1.4.2 Removing the MDCIC

Use the following steps to remove the MDCIC from the mounting panel. Refer to *Illustration 1.4* and *Illustration 1.5*.

NOTICE

BEFORE DISASSEMBLY

To make cable reinstallation easier, note the position of the following cables before disassembly:

- Inverter module ribbon cables.
- Rectifier control cables.
- STO cable (if any).

1. Disconnect the control card ribbon cable from connector MK100 on the MDCIC by gently pulling the cable to the left.

2. Disconnect the inverter module ribbon cables from the MDCIC.
3. Unplug the rectifier control cables from connectors MK101 and MK102 on the MDCIC. There is 1 cable for F1–F4 enclosures, or 2 cables for F10–F13 enclosures.
4. Remove the MDCIC by detaching the 9 screws (T25) securing the card to the panel standoffs.
5. Remove the scaling cards from the MDCIC. Retain the scaling cards (1 per module) for reinstallation on the new MDCIC.

1.5 Installation Guidelines

1.5.1 Installing the MDCIC

Use the following procedure to install the new MDCIC. Refer to *Illustration 1.4* and *Illustration 1.5*.

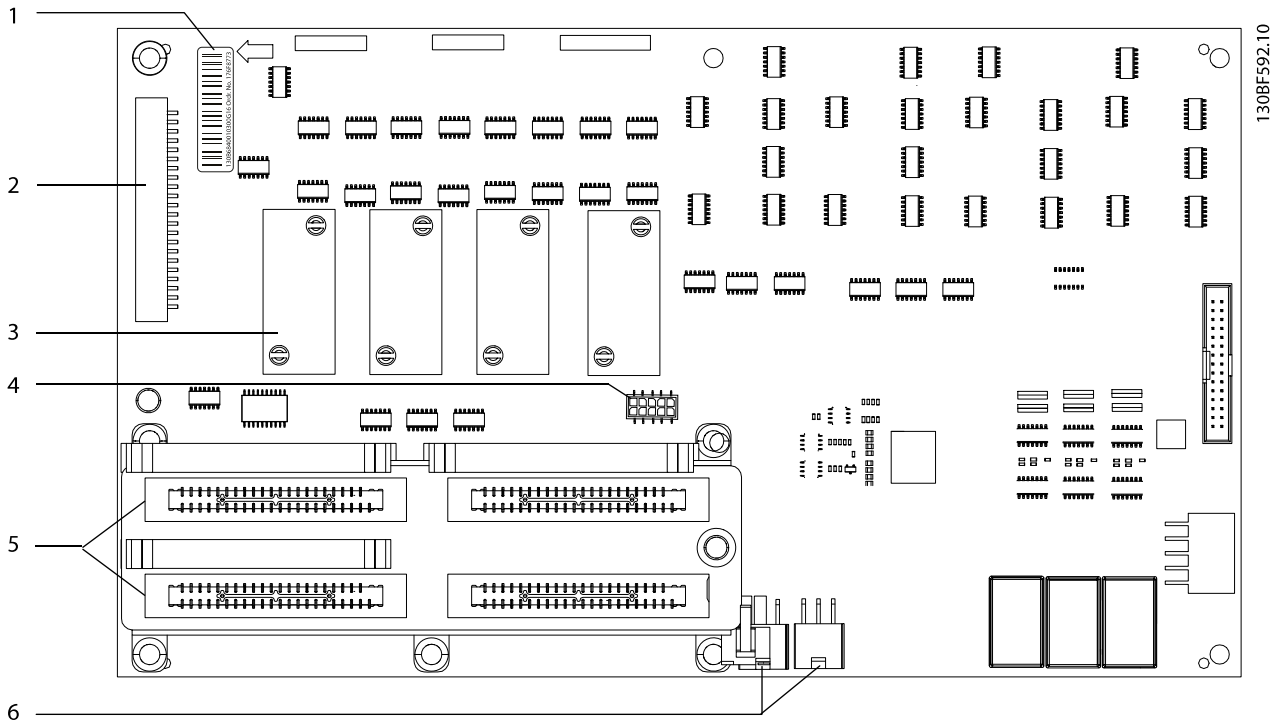

1	Barcode label	4	Safe Torque Off (STO) cable connector (MK111)
2	Control card cable connector (MK100)	5	Inverter module cable connectors (Inverter 1–4)
3	Scaling card	6	Rectifier cable connectors (MK101 and MK102)

Illustration 1.5 MDCIC Detail

1. Reinstall the old scaling cards on the new MDCIC.
2. Attach the new MDCIC to the panel standoffs using 9 screws (T25). Torque to 1.2 Nm (10 in-lb).
3. Connect the inverter module ribbon cables to their original positions (Inverter 1–4) on the MDCIC.
4. Attach the 6-pin rectifier control cables to connectors MK101 and MK102. There is 1 cable for F1–F4 enclosures, or 2 cables for F10–F13 enclosures.
5. Attach the control card ribbon cable to connector MK100.
6. Attach the STO cable to MK111. If no STO cable is present, check that the jumper cable is attached to MK111.
7. Reinstall the MDCIC cover using 2 screws (8 mm). Torque to 2.3 Nm (20 in-lb).

Danfoss can accept no responsibility for possible errors in catalogues, brochures and other printed material. Danfoss reserves the right to alter its products without notice. This also applies to products already on order provided that such alterations can be made without consequential changes being necessary in specifications already agreed. All trademarks in this material are property of the respective companies. Danfoss and the Danfoss logotype are trademarks of Danfoss A/S. All rights reserved.

