

Installation Guide

# Modbus TCP Card

VLT® Soft Starter MCD 600





## Contents

<b>1</b>	<b>Safety</b>	<b>5</b>
1.1	Disclaimer	5
1.2	Warnings	5
<b>2</b>	<b>Introduction</b>	<b>6</b>
2.1	Product Design	6
2.2	Compatibility	6
2.3	Network Connection	6
<b>3</b>	<b>Installation</b>	<b>7</b>
3.1	Installing the Expansion Card	7
3.2	Network Connections	7
3.2.1	Ethernet Ports	7
3.2.2	Cables	7
3.2.3	EMC Precautions	7
3.3	Network Establishment	7
3.4	Addressing	7
<b>4</b>	<b>Device Configuration</b>	<b>8</b>
4.1	Before Configuring the Device	8
4.2	Configuration Methods	8
4.3	Parameters for Configuring Network Settings	8
4.4	Enabling Network Control	8
4.5	On-board Web Server	9
4.5.1	Connect to the Device	9
4.5.2	Manage Users and Passwords	10
4.5.2.1	Adding a User	10
4.5.2.2	Deleting a User	10
4.5.3	Configuring the IP Address	11
4.5.4	Configure IoT Settings	11
4.5.4.1	Configuring MQTT Settings	12
4.5.4.2	Configuring OPC UA Settings	13
4.6	Scanning the Network	13
4.6.1	Identifying the Device with Ethernet Device Configuration Tool	13
<b>5</b>	<b>PLC Configuration</b>	<b>15</b>
5.1	Configuration Requirements for PLC	15

---

<b>6</b>	<b>Operation</b>	<b>16</b>
6.1	Requirements for Successful Operation	16
6.2	Device Classification	16
6.3	Ensuring Safe and Successful Control	16
6.4	Feedback LEDs	16
<b>7</b>	<b>Modbus Registers</b>	<b>17</b>
7.1	Important Information	17
7.2	Command and Configuration Registers (Read/Write)	17
7.3	Parameter Management	17
7.3.1	Writing Parameters to the Soft Starter	18
7.4	Status Reporting Registers (Read Only)	18
7.5	Legacy Mode	20
7.5.1	Initializing Legacy Mode	20
7.5.2	Registers	20
7.6	Trip Codes	24
<b>8</b>	<b>Network Design</b>	<b>26</b>
8.1	Star Topology	26
8.2	Line Topology	26
8.3	Ring Topology	27
8.4	Combined Topologies	27
<b>9</b>	<b>Specifications</b>	<b>29</b>
9.1	Connections	29
9.2	Settings	29
9.3	Network	29
9.4	Power	29
9.5	Certification	29



## 1 Safety

### 1.1 Disclaimer

The examples and diagrams in this manual are included solely for illustrative purposes. The information contained in this manual is subject to change at any time and without prior notice. Responsibility or liability is never accepted for direct, indirect, or consequential damage resulting from the use or application of this equipment.

### 1.2 Warnings

#### ⚠ W A R N I N G ⚠

##### SHOCK HAZARD

Attaching or removing accessories while the soft starter is connected to mains voltage may cause personal injury.

- Before attaching or removing accessories, isolate the soft starter from mains voltage.

#### ⚠ W A R N I N G ⚠

##### RISK OF PERSONAL INJURY AND EQUIPMENT DAMAGE

Inserting foreign objects or touching the inside of the soft starter while the expansion port cover is open may endanger personnel and can damage the soft starter.

- Do not insert foreign objects in the soft starter with the port cover open.
- Do not touch the inside of the soft starter with the port cover open.

## 2 Introduction

### 2.1 Product Design

The Modbus TCP Card allows the soft starter to connect to an Ethernet network and be controlled or monitored using an Ethernet communication model.

Familiarity with Ethernet protocols and networks is required to operate the device successfully. For difficulties arising from using this device with 3<sup>rd</sup>-party products, including PLCs, scanners, and commissioning tools, contact the relevant supplier.

### 2.2 Compatibility

This communication expansion card is suitable for use with VLT® Soft Starter MCD 600.

This Installation Guide is intended for use with version 2.x of the VLT® Soft Starter MCD 600 Modbus TCP Card. Version 1.x of the Modbus TCP Card does not support custom users, TCP connection, or IoT operation.

### 2.3 Network Connection

Table 1: Supported Protocols

Protocols	
Modbus TCP	Industrial Ethernet via Modbus TCP
TCP	Transmission control protocol to connect to port 4000 of a PC
MQTT	Message queue telemetry transport
OPC UA	Open platform communications unified architecture

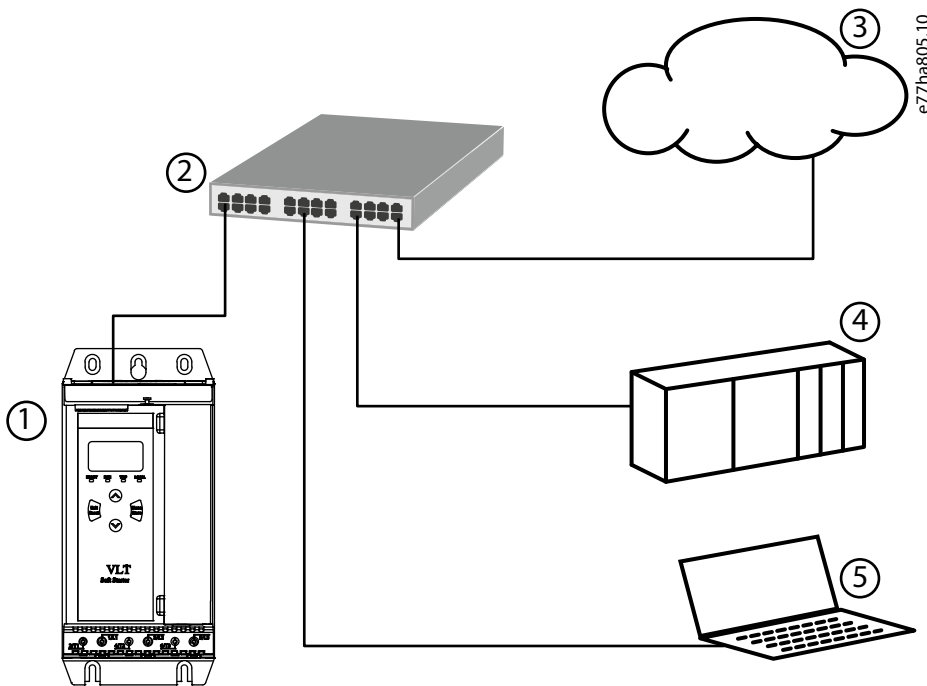
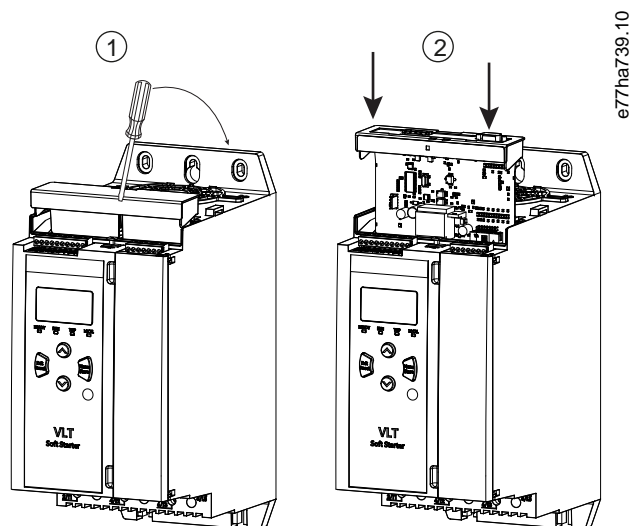

Illustration 1: Overview of Network Connections

1	Soft starter	4	Industrial Ethernet connection to programmable logic controller
2	Network switch	5	TCP connection to VLT® Motion Control Tool MCT 10. Refer to the VLT® Motion Control Tool MCT 10 Operating Guide for connection details.
3	IoT connection (MQTT/OPC UA)		

## 3 Installation

### 3.1 Installing the Expansion Card



#### Procedure

1. Push a small flat-bladed screwdriver into the slot in the center of the expansion port cover and ease the cover away from the soft starter.
2. Align the card with the expansion port. Gently push the card along the guide rails until it clicks into the soft starter.

### 3.2 Network Connections

#### 3.2.1 Ethernet Ports

The device has 2 Ethernet ports. If only 1 connection is required, either port can be used.

#### 3.2.2 Cables

When connecting to the device, make sure that the cables are of 1 of the following categories:

- Category 5
- Category 5e
- Category 6
- Category 6e

#### 3.2.3 EMC Precautions

To minimize electromagnetic interference, Ethernet cables should be separated from motor and mains cables by 200 mm (7.9 in). If the Ethernet cable must cross motor or mains cables, the crossing should be at an angle of 90°.

### 3.3 Network Establishment

The controller must establish communications directly with each device before the device can participate in the network.

### 3.4 Addressing

Each device in a network is addressed using a MAC address and an IP address.

- The device can be assigned a static IP address during configuration or can be configured to accept a dynamic IP address (via DHCP).
- The MAC address is fixed within the device and is printed on a label on the front of the device.

## 4 Device Configuration

### 4.1 Before Configuring the Device

#### NOTICE

The error LED flashes whenever the device is receiving power but is not connected to a network. The error LED will flash occasionally during the configuration process.

#### NOTICE

At power-up, the communication card loads the IP address stored in the soft starter.

### 4.2 Configuration Methods

Network communication parameters for the communication card can be set via the soft starter or via the on-board web server.

- The card uses a static IP address by default. To enable DHCP addressing, set *parameter 12–20 DHCP* to enable or change the setting via the on-board web server.
- The IP address can be set via the programmable parameters of the soft starter.
- The web server can configure the IP address and messaging settings for MQTT/OPC UA operation.

### 4.3 Parameters for Configuring Network Settings

Use *parameters 12-8 to 12-21* to configure the network address. The parameters can be set via the Main Menu, via the Setup Tools, or by uploading a configuration file via USB Save & Load.

Parameter	Default
12-8 Gateway Address	192
12-9 Gateway Address 2	168
12-10 Gateway Address 3	0
12-11 Gateway Address 4	100
12-12 IP Address	192
12-13 IP Address 2	168
12-14 IP Address 3	0
12-15 IP Address 4	2
12-16 Subnet Mask	255
12-17 Subnet Mask 2	255
12-18 Subnet Mask 3	255
12-19 Subnet Mask 4	0
12-20 DHCP	Disable
12-21 Location ID	0

### 4.4 Enabling Network Control

#### NOTICE

If the reset input is active, the soft starter does not operate. If a reset switch is not required, use *parameter 7-9* to set the reset input to normally open or fit a link across terminals RESET, COM+ on the soft starter.



Procedure

1. Set parameter 1-1 Command Source to Network for the soft starter to accept commands from the Modbus TCP Card.

## 4.5 On-board Web Server

### 4.5.1 Connect to the Device

To configure settings using the on-board web server, the Modbus TCP Card must be installed in a soft starter, control power must be available, and the card and computer must both be connected to the Ethernet network.

The computer must use a fixed IP address (not DHCP) and the same subnet mask as the card. The default IP address for the card is 192.168.0.2. The default subnet mask is 255.255.255.0.

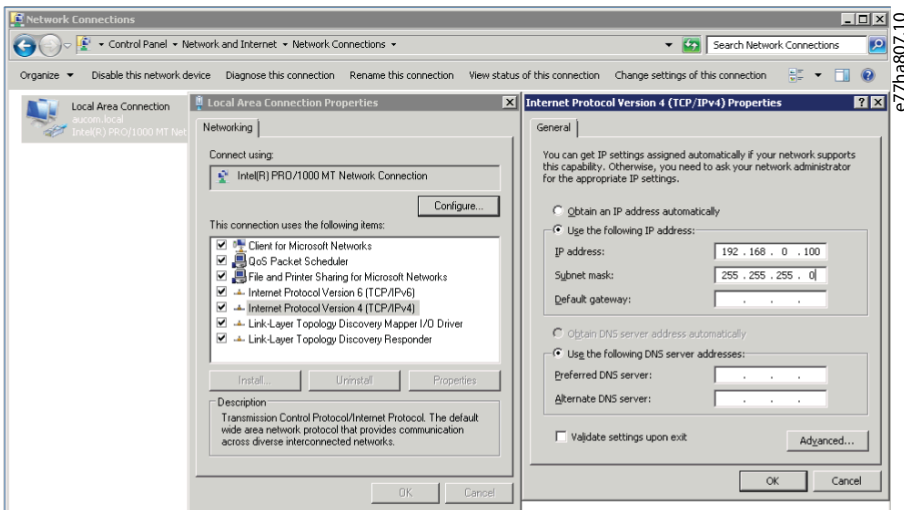

Once connected, the web server reports basic information about the card and the soft starter.

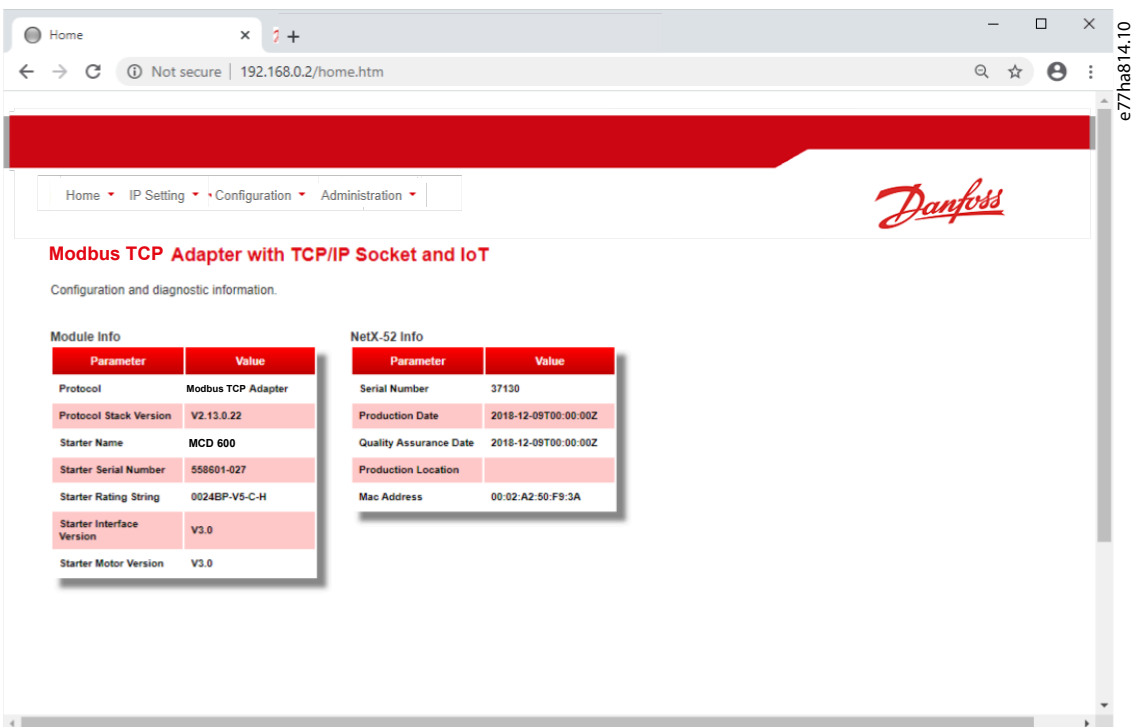

### 4.5.2 Manage Users and Passwords

#### NOTICE

For security reasons, define a custom administrator ID and password. The default username and password are:

- Username: danfoss\_admin
- Password: danfoss\_admin

#### NOTICE

Version 1.x of the Modbus TCP Card does not support custom users.

The Modbus TCP Card supports multiple users and levels of privilege.

- Users can view the home screen and IP settings.
- Supervisors can view the home screen and IP settings, and they can change configuration settings.
- Administrators can view the home screen, change configuration settings, and add or delete users.

#### 4.5.2.1 Adding a User

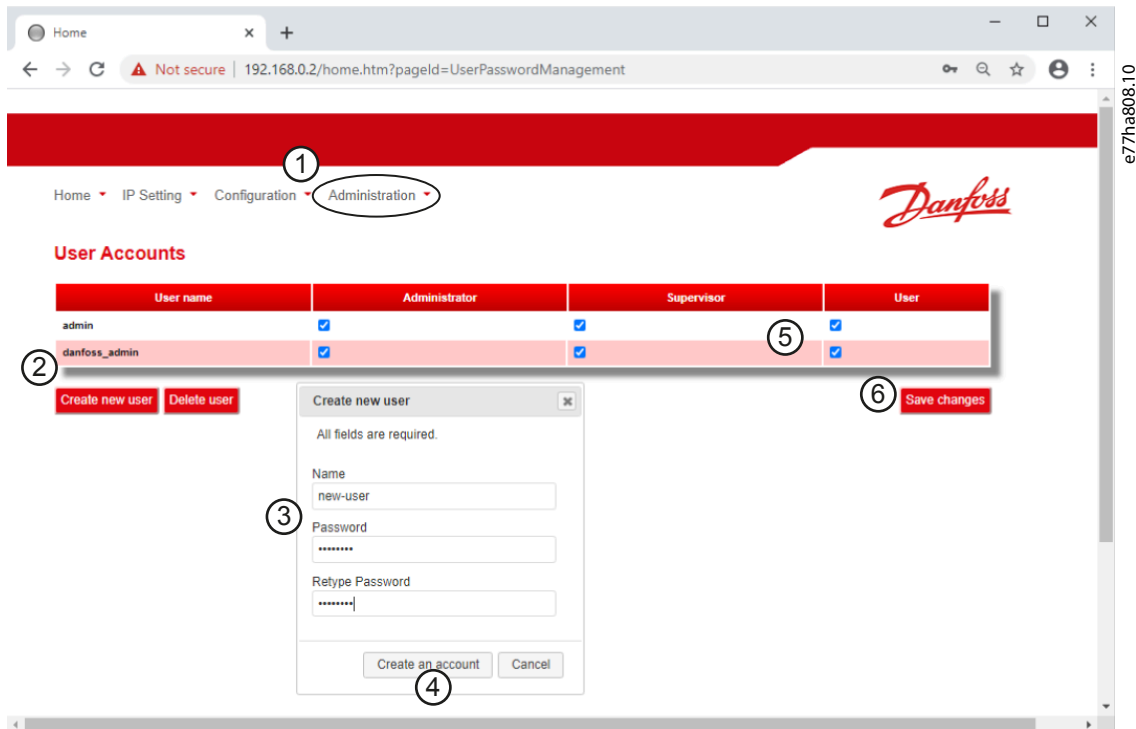

#### Procedure

1. Connect to the web server and click *Administration*.
2. Click *Create new user*.
3. Enter the new username and password.
4. Click *Create an account*.
5. Set privileges (user, supervisor, administrator) as appropriate.
6. Click *Save changes*.

#### 4.5.2.2 Deleting a User

#### Procedure

1. Connect to the web server and click *Administration*.
2. Select the required entry in the user list and click *Delete*.
3. Click *Delete* again to confirm the action.

### 4.5.3 Configuring the IP Address

#### NOTICE

For version 1.x of the Modbus TCP Card, changes made via the web server are not stored in the soft starter and will be lost when control power is cycled.

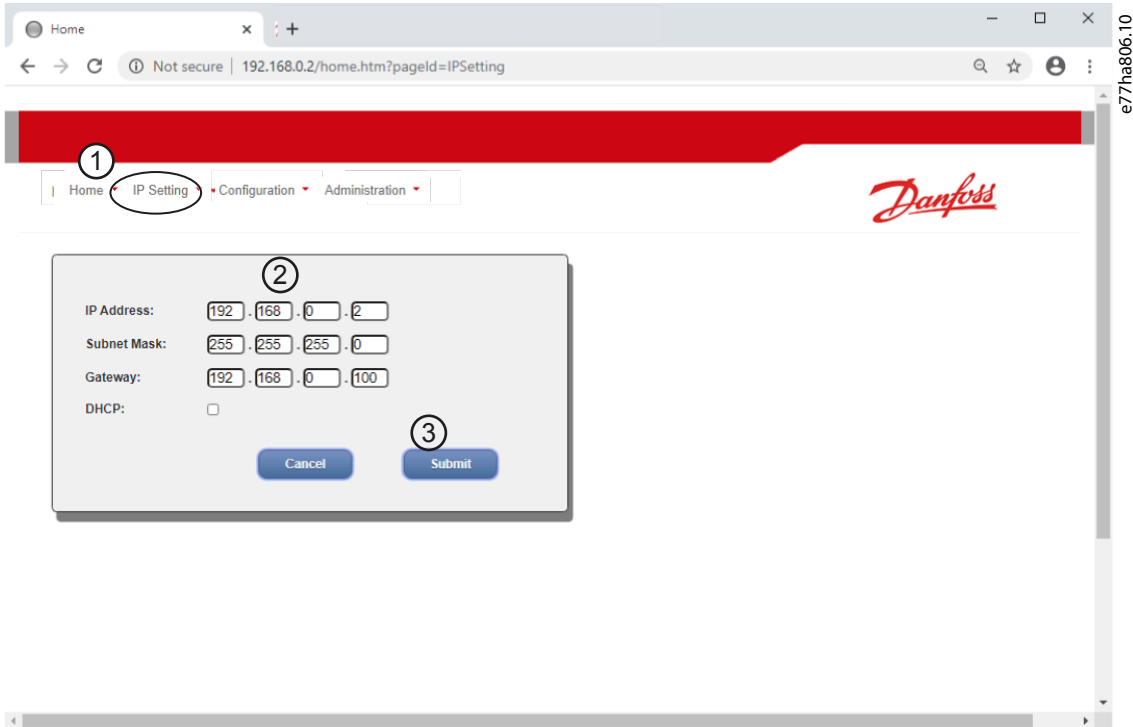

**Procedure**

1. Connect to the web server and click *IP Setting*.
2. Edit settings as required. To enable DHCP addressing, tick the DHCP checkbox.
3. Click *Submit* to send the new settings to the device.

### 4.5.4 Configure IoT Settings

The Modbus TCP Card supports soft starter status monitoring via IoT. The card cannot control or program the soft starter.

#### NOTICE

Version 1.x of the Modbus TCP Card does not support IoT operation.

### 4.5.4.1 Configuring MQTT Settings

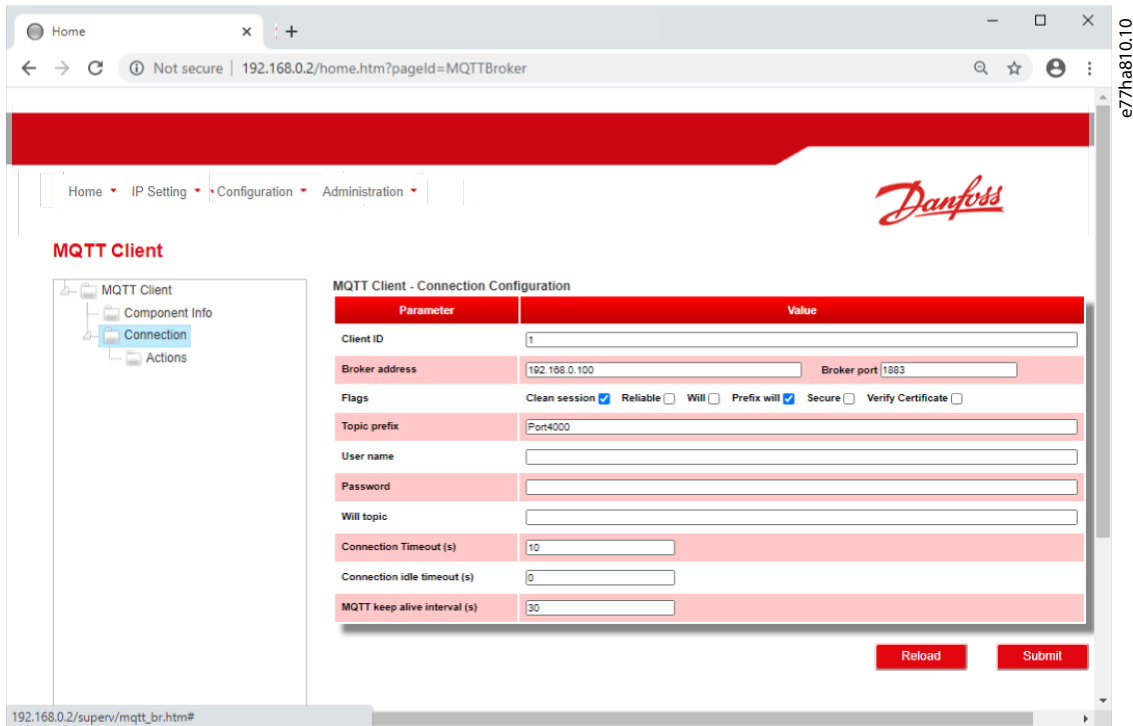

MQTT Client - Connection Configuration

Parameter	Value
Client ID	1
Broker address	192.168.0.100
Broker port	1883
Flags	Clean session <input checked="" type="checkbox"/> Reliable <input type="checkbox"/> Will <input type="checkbox"/> Prefix will <input checked="" type="checkbox"/> Secure <input type="checkbox"/> Verify Certificate <input type="checkbox"/>
Topic prefix	Port4000
User name	
Password	
Will topic	
Connection Timeout (s)	10
Connection idle timeout (s)	0
MQTT keep alive interval (s)	30

Reload Submit

#### Procedure

1. Connect to the web server and click *Configuration*.
2. Select *MQTT Client*.
3. Tick the *Enable* checkbox to enable MQTT client operation.

The MQTT client is enabled by default.

4. Click *Connection* and configure the settings as required.
5. Click *Connections* ⇒ *Actions* to select which information the card should publish.
6. Click *Submit* to save all settings in the card.



### 4.5.4.2 Configuring OPC UA Settings

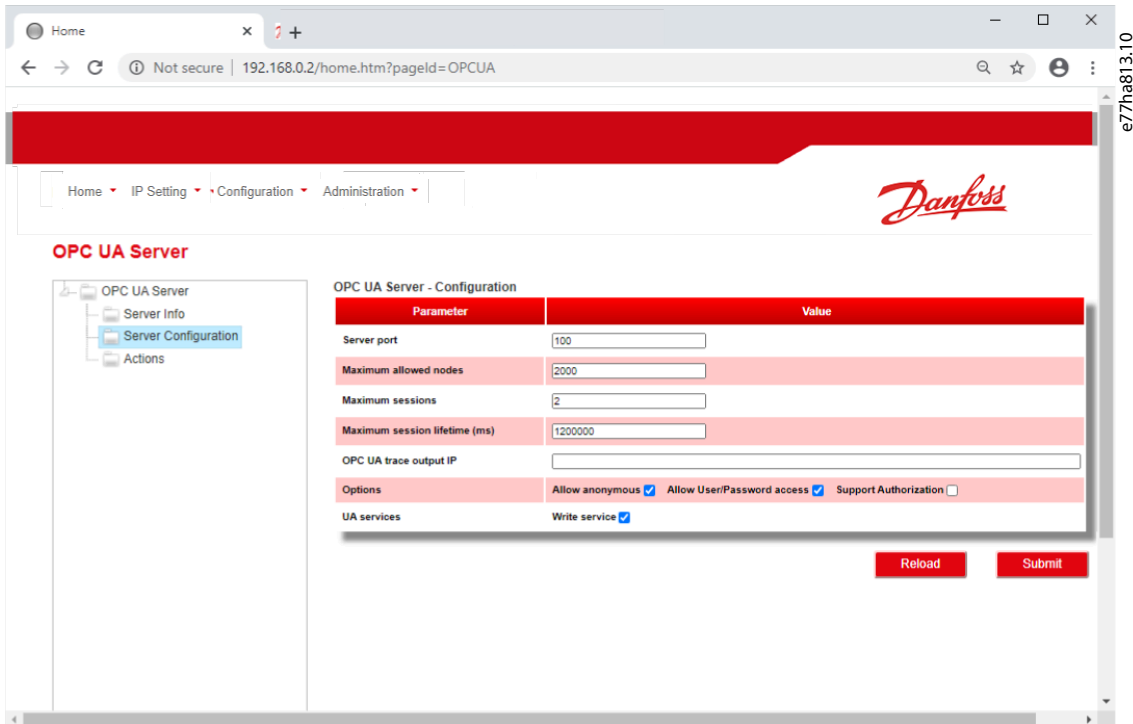

#### Procedure

1. Connect to the web server and click *Configuration*.
2. Select *OPC UA Server*.
3. Tick the *Enable* checkbox to enable OPC UA client operation.

The OPC UA client is enabled by default.

4. Click *Server Configuration* and configure the settings as required.
5. Select *Actions* to select the actions for different object instances.
6. Click *Submit* to save all settings in the card.

## 4.6 Scanning the Network

If there is no connection to the web server and the soft starter cannot be accessed physically, use the Ethernet Device Configuration Tool to scan the network and identify the device. Changes made via the Ethernet Device Configuration Tool cannot be stored permanently in the device and will be lost when the control power is cycled.

Download the Ethernet Device Configuration Tool from [www.danfoss.com](http://www.danfoss.com) under the sections Services/PC-tools.

### NOTICE

If the PC has a firewall enabled, add the tool to the list of authorized programs.

### 4.6.1 Identifying the Device with Ethernet Device Configuration Tool

#### Procedure

1. Start the Ethernet Device Configuration Tool.
2. Click *Search Devices*.

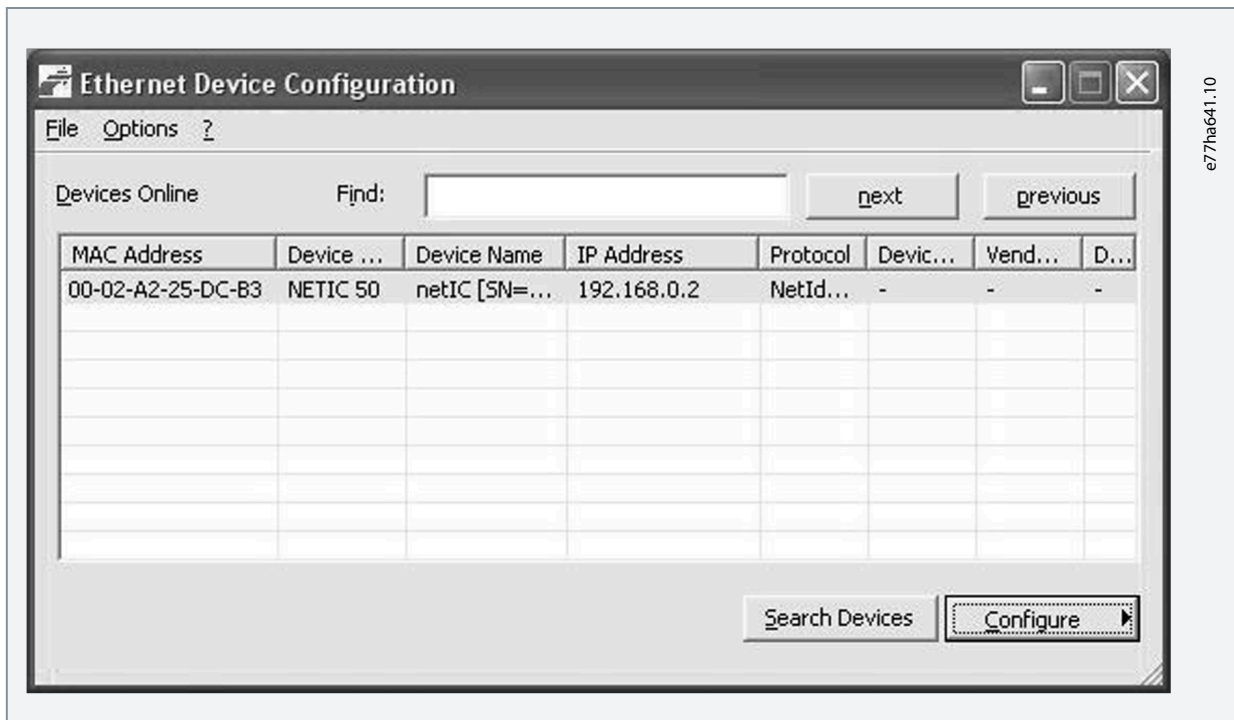

➡ The software searches for connected devices.

3. Use the IP address to connect to the device via the web server.

## 5 PLC Configuration

### 5.1 Configuration Requirements for PLC

The PLC must be configured to map registers within the communication card to addresses within the PLC.

The device must be configured directly in the PLC. No extra files are required.

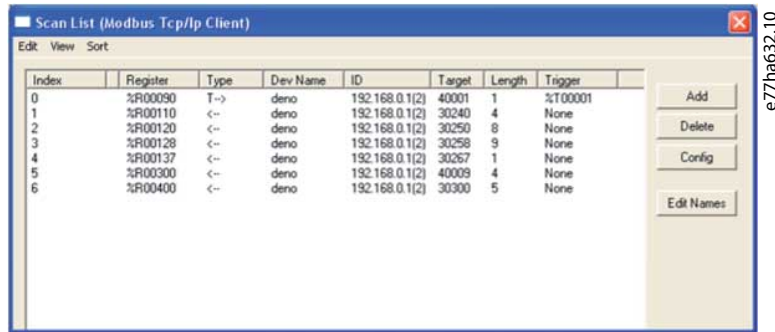

e77/ha632.10

## 6 Operation

### 6.1 Requirements for Successful Operation

The Modbus TCP Card must be controlled by a Modbus client (such as a PLC), which complies with the Modbus Protocol Specification. For successful operation, the client must also support all functions and interfaces described in this manual.

### NOTICE

The available features and parameter details may vary according to the model and software version of the soft starter. Refer to the VLT® Soft Starter MCD 600 Operating Guide for details of parameters and supported features.

### 6.2 Device Classification

The Modbus TCP Card is a Modbus server and must be managed by a Modbus client over Ethernet.

### 6.3 Ensuring Safe and Successful Control

Data written to the device remains in its registers until the data is overwritten or the device is reinitialized. If the soft starter is controlled via *parameter 7-1 Command Override* or is disabled via the reset input (terminals RESET, COM+), fieldbus commands should be cleared from the registers. If a command is not cleared, it is re-sent to the soft starter once fieldbus control resumes.

### 6.4 Feedback LEDs

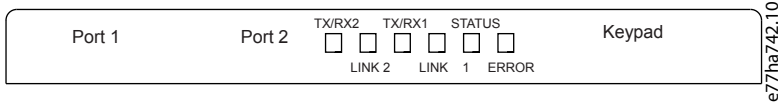

Table 2: LED Descriptions

LED name	LED state	Description
Error	Off	No error.
	Flashing	System error.
	On	Communication error.
Status	Off	The device is not powered up.
	Slow flash	The device is ready but not configured.
	Fast flash	Communication has been established.
Link x	Off	No network connection.
	On	Connected to a network.
TX/RX x	Flashing	Transmitting or receiving data.
	Off	No network connection.



## 7 Modbus Registers

### 7.1 Important Information

#### NOTICE

The available features and parameter details may vary according to the model and software version of the soft starter. Refer to the VLT® Soft Starter MCD 600 Operating Guide for details of parameters and supported features.

#### NOTICE

All references to registers mean the registers within the communication card unless otherwise stated.

### 7.2 Command and Configuration Registers (Read/Write)

Table 3: Details of Command and Configuration Registers

Register	Description	Bits	Details
40001	Command (single write)	0–7	To send a command to the soft starter, write the required value: 00000000 = Stop 00000001 = Start 00000010 = Reset 00000100 = Quick stop (coast to stop) 00001000 = Forced communication trip 00010000 = Start using Parameter Set 1 00100000 = Start using Parameter Set 2 01000000 = Reserved 10000000 = Reserved
		8–14	Reserved
		15	Must = 1
40002	Reserved		
40003	Reserved		
40004	Reserved		
40005	Reserved		
40006	Reserved		
40007	Reserved		
40008	Reserved		
40009–40xxx	Parameter management (single/multiple read or multiple write)	0–15	Manage soft starter programmable parameters.

### 7.3 Parameter Management

Parameters can be read from and written to the soft starter. When writing parameters to the soft starter, every parameter is updated to match the values in the PLC.

#### NOTICE

While parameters are being written, the soft starter cannot start/stop the motor.

The Modbus TCP protocol limits read/write operations to a maximum of 123 registers at one time. The registers must be consecutive.

To avoid loss of communications due to an unintentional change of network configuration, write the network address parameter settings before writing start/stop parameter settings.

### 7.3.1 Writing Parameters to the Soft Starter

#### N O T I C E

For reliable operation, the parameter block containing network configuration settings must be written first.

**Procedure**

1. Configure all soft starter parameter values in the PLC as required, including IP address, gateway address, subnet mask, and DHCP configuration.
2. Write the parameter block that includes the network parameter settings from the PLC to the soft starter.
3. Write the other parameter blocks from the PLC to the soft starter until all parameter values have been written.

### 7.4 Status Reporting Registers (Read Only)

#### N O T I C E

For models MCD6-0063B and smaller (soft starter model ID 1~4), the current reported via communications registers is 10 times greater than the actual value.

**Table 4: Description of Read Registers**

Register	Description	Bits	Details
30003	Reserved		
30004	Reserved		
30005	Reserved		
30006	Reserved		
30007	Reserved		
30008	Reserved		
30600	Product information	0–5	Binary protocol version
		6–8	Parameter list major version
		9–15	Product type code: 15 = MCD 600
30601	Model number	0–7	Reserved
		8–15	Soft starter model ID
30602	Reserved		
30603	Reserved		
30604	Starter state	0–4	0 = Reserved 1 = Ready 2 = Starting 3 = Running 4 = Stopping 5 = Not ready (restart delay, restart temperature check, run simulation, reset input is open) 6 = Tripped 7 = Programming mode

Register	Description	Bits	Details
			8 = Jog forward 9 = Jog reverse
		5	1 = Warning
		6	0 = Uninitialized 1 = Initialized
		7	Command source 0 = Remote LCP, Digital Input, Clock 1 = Network
		8	Reserved
		9	0 = Negative phase sequence 1 = Positive phase sequence
		10–15	Reserved
30605	Current	0–13	Average rms current across all 3 phases
		14–15	Reserved
30606	Current	0–9	Current (% motor FLC)
		10–15	Reserved
30607	Motor temperature	0–7	Motor thermal model (%)
		8–15	Reserved
30608	Power	0–11	Power
		12–13	Power scale 0 = Multiply power by 10 to get W 1 = Multiply power by 100 to get W 2 = Power (kW) 3 = Multiply power by 10 to get kW
		14–15	Reserved
30609	% Power factor	0–7	100% = power factor of 1
		8–15	Reserved
30610	Voltage	0–13	Average rms voltage across all 3 phases
		14–15	Reserved
30611	Current	0–13	Phase 1 current (rms)
		14–15	Reserved
30612	Current	0–13	Phase 2 current (rms)
		14–15	Reserved
30613	Current	0–13	Phase 3 current (rms)
		14–15	Reserved

Register	Description	Bits	Details
30614	Voltage	0–13	Phase 1 voltage
		14–15	Reserved
30615	Voltage	0–13	Phase 2 voltage
		14–15	Reserved
30616	Voltage	0–13	Phase 3 voltage
		14–15	Reserved
30617	Parameter list version number	0–7	Parameter list minor revision
		8–15	Parameter list major version
30618	Digital input state	0–15	For all inputs, 0 = open, 1 = closed (shorted) 0 = Start/Stop 1 = Reserved 2 = Reset 3 = Input A 4 = Input B 5–15 = Reserved
30619	Trip code	0–15	See the chapter Trip Codes.
		8–15	Reserved
30620–30631	Reserved		

## N O T I C E

The reset input is normally closed by default. If parameter 7-9 Reset/Enable Logic is set to normally open, the reported state is inverted (0 = closed, 1 = open).

## 7.5 Legacy Mode

The Modbus TCP Card can also operate in Legacy Mode, which uses the same registers as the clip-on Modbus RTU Module supplied by Danfoss for use with older soft starters. Some registers differ from those specified in the Modbus protocol specification.

### 7.5.1 Initializing Legacy Mode

If the card has been operating in Standard Mode, it must be reset before communicating in Legacy Mode. To initialize the card for Legacy Mode, either:

- cycle control power, or
- reset register 40001 to 0 (write 0 to bits 0–15).

### 7.5.2 Registers

## N O T I C E

For models MCD6-0063B and smaller, the current reported via communications registers is 10 times greater than the actual value.

## N O T I C E

Legacy Mode reports read-only status information in registers 40003 onwards to match the register definitions of the clip-on Modbus Module. Identical data is also available via registers 30003 onwards.



Table 5: Description of Registers in Legacy Mode

Register	Description	Bits	Details
40001	Reserved		
40002	Command (single write)	0–2	To send a command to the starter, write the required value: 1 = Start 2 = Stop 3 = Reset 4 = Quick stop (coast to stop) 5 = Forced communication trip 6 = Start using Parameter Set 1 7 = Start using Parameter Set 2
		3–15	Reserved
40003	Soft starter state	0–3	1 = Ready 2 = Starting 3 = Running 4 = Stopping (including braking) 5 = Restart delay (including temperature check) 6 = Tripped 7 = Programming mode 8 = Jog forward 9 = Jog reverse
		4	1 = Positive phase sequence (only valid if bit 6 = 1)
		5	1 = Current exceeds FLC
		6	0 = Uninitialized 1 = Initialized
		7–15	Reserved
40004	Reserved		
40005	Motor current	0–7	Average 3-phase motor current (A)
		8–15	Reserved
40006	Motor temperature	0–7	Motor thermal model (%)
		8–15	Reserved
40007	Reserved		
40008	Reserved		
40009–40xxx	Parameter management (single or multiple read/ write)	0–7	Manage soft starter programmable parameters. See the VLT® Soft Starter MCD 600 Operating Guide for a complete parameter list.
		8–15	Reserved
40600	Version	0–5	Binary protocol version
		6–8	Parameter list version number
		9–15	Product type code:

Register	Description	Bits	Details
			15 = MCD 600
40601	Model number	0–7	Reserved
		8–15	Soft starter model ID
40602	Reserved		
40603	Reserved		
40604	Starter state	0–4	0 = Reserved 1 = Ready 2 = Starting 3 = Running 4 = Stopping 5 = Not ready (restart delay, restart temperature check, run simulation, reset input is open) 6 = Tripped 7 = Programming mode 8 = Jog forward 9 = Jog reverse
		5	1 = Warning
		6	0 = Uninitialized 1 = Initialized
		7	Command source 0 = Remote LCP, Digital Input, Clock 1 = Network
		8	Reserved
		9	0 = Negative phase sequence 1 = Positive phase sequence
		10–15	Reserved
40605	Current	0–13	Average rms current across all 3 phases
		14–15	Reserved
40606	Current	0–9	Current (% motor FLC)
		10–15	Reserved
40607	Motor temperature	0–7	Motor thermal model (%)
		8–15	Reserved
40608	Power	0–11	Power
		12–13	Power scale 0 = Multiply power by 10 to get W 1 = Multiply power by 100 to get W 2 = Power (kW) 3 = Multiply power by 10 to get kW

Register	Description	Bits	Details
		14–15	Reserved
40609	% Power factor	0–7	100% = power factor of 1
		8–15	Reserved
40610	Voltage	0–13	Average rms voltage across all 3 phases
		14–15	Reserved
40611	Current	0–13	Phase 1 current (rms)
		14–15	Reserved
40612	Current	0–13	Phase 2 current (rms)
		14–15	Reserved
40613	Current	0–13	Phase 3 current (rms)
		14–15	Reserved
40614	Voltage	0–13	Phase 1 voltage
		14–15	Reserved
40615	Voltage	0–13	Phase 2 voltage
		14–15	Reserved
40616	Voltage	0–13	Phase 3 voltage
		14–15	Reserved
40617	Parameter list version number	0–7	Parameter list minor revision
		8–15	Parameter list major version
40618	Digital input state	0–15	For all inputs, 0 = open, 1 = closed (shorted) 0 = Start/Stop 1 = Reserved 2 = Reset 3 = Input A 4 = Input B 5–15 = Reserved
40619	Trip code	0–7	See the chapter Trip Codes
		8–15	Reserved
40620–40631	Reserved		

## N O T I C E

The reset input is normally closed by default. If parameter 7-9 Reset/Enable Logic is set to normally open, the reported state is inverted (0 = closed, 1 = open).

## 7.6 Trip Codes

Code	Description
255	No trip
1	Excess start time
2	Motor overload
3	Motor thermistor
4	Current imbalance
5	Frequency
6	Phase sequence
7	Overcurrent
8	Power loss
9	Undercurrent
10	Heat sink overtemperature
11	Motor connection
12	Input A trip
13	FLC too high
14	Unsupported option (function not available in inside delta)
15	Communications card fault
16	Network communication
18	Overvoltage
19	Undervoltage
23	Parameter out of range
20	Motor overload
24	Input B trip
26	L1 phase loss
27	L2 phase loss
28	L3 phase loss
29	L1-T1 shorted
30	L2-T2 shorted
31	L3-T3 shorted
33	Time-overcurrent (bypass overload)
34	SCR overtemperature
35	Battery/clock
36	Thermistor circuit

Code	Description
47	Overpower
48	Underpower
56	LCP disconnected
57	Zero speed detect
58	SCR Itsm
59	Instantaneous overcurrent
60	Rating capacity
70	Current Read Err L1
71	Current Read Err L2
72	Current Read Err L3
74	Motor connection T1
75	Motor connection T2
76	Motor connection T3
77	Firing fail P1
78	Firing fail P2
79	Firing fail P3
80	VZC fail P1
81	VZC fail P2
82	VZC fail P3
83	Low control volts
84–96	Internal fault x. Contact the local supplier with the fault code (x).

## 8 Network Design

### 8.1 Star Topology

In a star network, all controllers and devices connect to a central network switch.

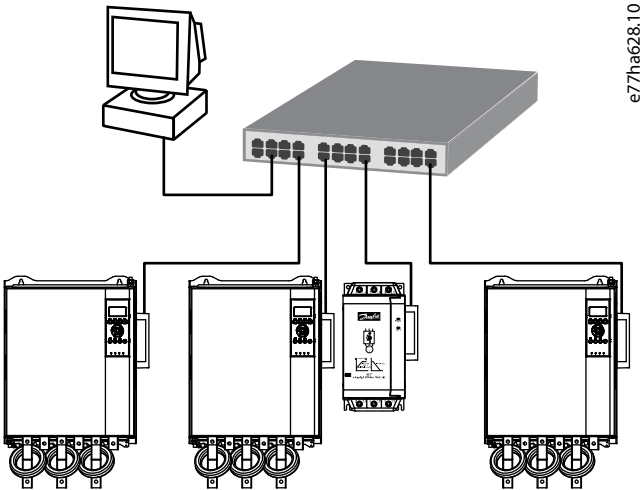

Illustration 2: Example of Star Topology

### 8.2 Line Topology

In a line network, the controller connects directly to 1 port of the 1<sup>st</sup> card. The 2<sup>nd</sup> Ethernet port connects to another card, which in turn connects to another device until all devices are connected.

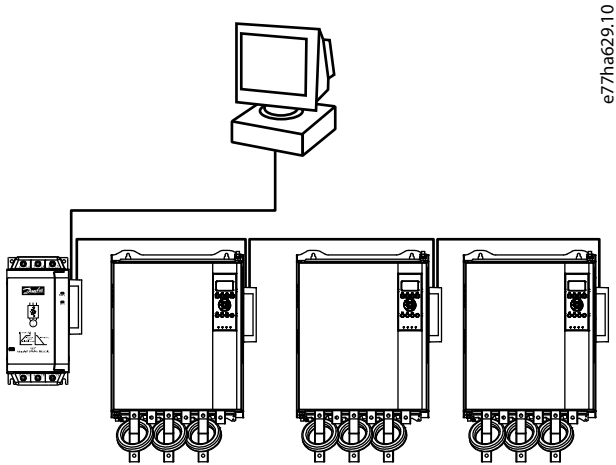

Illustration 3: Example of Line Topology

#### NOTICE

The device has an integrated switch to allow data to pass through in line topology. The device must be receiving control power from the soft starter for the switch to operate.

#### NOTICE

If the connection between 2 devices is interrupted, the controller cannot communicate with devices after the interruption point.

## NOTICE

Each connection adds a delay to the communication with the next device. The maximum number of devices in a line network is 32. Exceeding this number may reduce the reliability of the network.

### 8.3 Ring Topology

In a ring topology network, the controller connects to the 1<sup>st</sup> card via a network switch. The 2<sup>nd</sup> Ethernet port of the card connects to another device, which in turn connects to another device until all devices are connected. The final device connects back to the switch.

The device supports beacon-based ring node configuration.

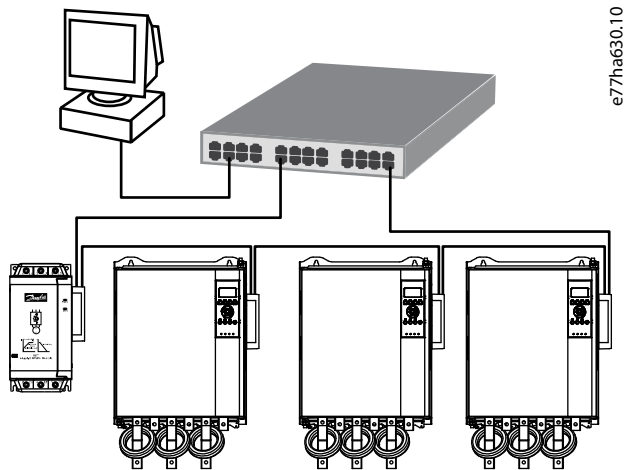

Illustration 4: Example of Ring Topology

## NOTICE

The network switch must support loss of line detection.

### 8.4 Combined Topologies

A single network can include both star and line components.

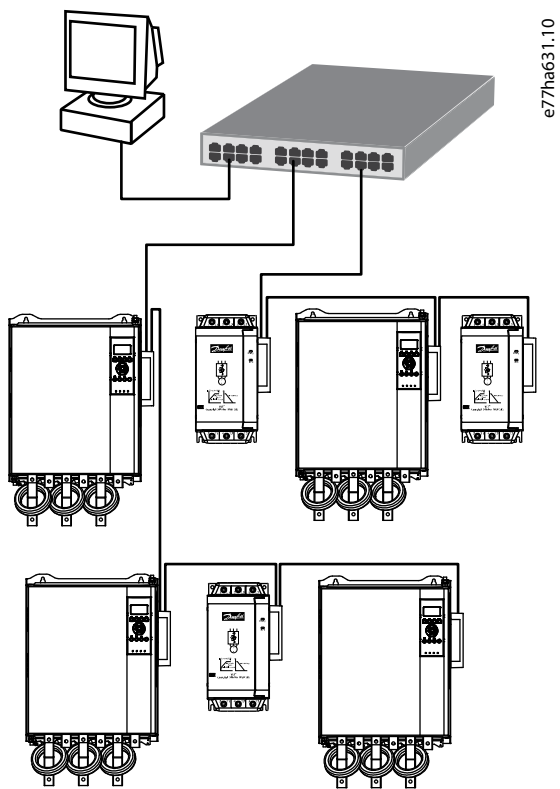

Illustration 5: Example of Combined Topologies



## 9 Specifications

### 9.1 Connections

Soft starter	6-way pin assembly
Contacts	Gold flash
Network	RJ45

### 9.2 Settings

IP address	Automatically assigned, configurable
Device name	Automatically assigned, configurable

### 9.3 Network

Link speed	10 Mbps, 100 Mbps (auto-detect)
Full duplex	
Auto crossover	

### 9.4 Power

Consumption (steady state, maximum)	35 mA@24 V DC
Reverse polarity protected	
Galvanically isolated	

### 9.5 Certification

RCM	IEC 60947-4-2
CE	EN 60947-4-2

**Danfoss A/S**  
Ulsnaes 1  
DK-6300 Graasten  
[vlt-drives.danfoss.com](http://vlt-drives.danfoss.com)

---

Danfoss can accept no responsibility for possible errors in catalogs, brochures and other printed material. Danfoss reserves the right to alter its products without notice. This also applies to products already on order provided that such alterations can be made without subsequential changes being necessary in specifications already agreed. All trademarks in this material are property of the respective companies. Danfoss and the Danfoss logotype are trademarks of Danfoss A/S. All rights reserved.

---

