

VACON[®] NXI
INVERTERS

FI4-FI8
USER MANUAL

VACON[®]

AT LEAST THE 10 FOLLOWING STEPS OF THE *START-UP QUICK GUIDE* MUST BE PERFORMED DURING THE INSTALLATION AND COMMISSIONING.

IF ANY PROBLEMS OCCUR, PLEASE CONTACT YOUR LOCAL DISTRIBUTOR.

Start-up Quick Guide

1. Check that the delivery corresponds to your order, see Chapter 3.
2. Before taking any commissioning actions, read carefully the safety instructions in Chapter 1.
3. Before the mechanical installation, check the minimum clearances around the unit and check the ambient conditions in Chapter 5.
4. Check the size of the motor cable, DC supply cable, and mains fuses, and check the cable connections. Read Chapters 6.1.1.1 – 6.1.1.6.
5. Follow the installation instructions, see Chapter 6.1.2.
6. The sizes and grounding of control connections are explained in Chapter 6.2.2.
7. If the Start-Up wizard is active, select the language you want the keypad and the application to use and confirm by pressing the enter button. If the Start-Up wizard is not active, follow the instructions in 7a and 7b below.
 - 7a. Select the language of the keypad from Menu M6, page 6.1. Instructions on using the keypad are given in Chapter 7.
 - 7b. Select the application you want to use from Menu M6, page 6.2. Instructions on using the keypad are given in Chapter 7.
8. All parameters have factory default values. To ensure proper operation, check the rating plate data for the values below and the corresponding parameters of parameter group G2.1.
 - nominal voltage of the motor
 - nominal frequency of the motor
 - nominal speed of the motor
 - nominal current of the motor
 - motor $\cos\phi$

All parameters are explained in the All in One Application Manual.
9. Follow the commissioning instructions, see Chapter 8.
10. The VACON[®] NX Inverter is now ready for use.

Vacon Ltd is not responsible for the use of the inverters against the instructions.

CONTENTS

VACON® NXI USER'S MANUAL

INDEX

1	SAFETY
2	EU DIRECTIVE
3	RECEIPT OF DELIVERY
4	TECHNICAL DATA
5	INSTALLATION
6	CABLING AND CONNECTIONS
7	CONTROL KEYPAD
8	COMMISSIONING
9	FAULT TRACING

ABOUT THE VACON® NXI USER'S MANUAL AND THE "All in One" APPLICATION MANUAL

Congratulations for choosing VACON® NX Inverters!

The User's Manual will provide you with the necessary information about the installation, commissioning and operation of VACON® NX Inverters. We recommend that you carefully study these instructions before powering up the inverter for the first time.

In the All in One Application Manual you will find information about the different applications included in the All in One Application Package. Should these applications not meet the requirements of your process, please contact the manufacturer for information on special applications.

This manual is available in both paper and electronic editions. We recommend you to use the electronic version if possible. If you have the **electronic version** at your disposal, you will be able to benefit from the following features:

The manual contains several links and cross-references to other locations in the manual, which makes it easier to move around in the manual. The reader can thus easily find and check things.

The manual also contains hyperlinks to web pages. To visit these web pages through the links, you must have an internet browser installed on your computer.

VACON® NX User's Manual

Document code: DPD00908C
Date: 22.3.2018

Index

1.	SAFETY	7
1.1	Warnings.....	7
1.2	Safety instructions.....	7
1.3	Grounding and earth fault protection.....	8
1.4	Running the motor.....	8
2.	EU DIRECTIVE	9
2.1	CE marking.....	9
2.2	EMC directive.....	9
2.2.1	Introduction.....	9
2.2.2	Technical criteria.....	9
2.2.3	VACON® inverter EMC classification.....	9
2.2.4	Manufacturer's declaration of conformity.....	9
3.	RECEIPT OF DELIVERY	11
3.1	Type designation code.....	11
3.1.1	FR4—FR8.....	11
3.1.2	The standard features of VACON® NX inverters.....	12
3.2	Storage.....	13
3.2.1	Capacitor reforming.....	13
3.3	Maintenance.....	13
3.4	Disposal.....	14
4.	TECHNICAL DATA	15
4.1	Introduction.....	15
4.2	Power ratings.....	17
4.2.1	Supply voltage 465-800 Vdc, Motor voltage 380—500 Vac.....	17
4.2.2	Supply voltage 640-1100 Vdc, Motor voltage 525—690 Vac.....	18
4.2.3	Overload capability.....	18
4.3	Technical information.....	20
4.4	Derating.....	22
4.4.1	Ambient temperature.....	22
4.4.2	High altitude installation.....	23
5.	INSTALLATION	25
5.1	Mounting.....	25
5.2	Fan cooling.....	31
5.2.1	Enclosure sizes FR4 to FR8.....	31
5.2.2	Power losses as function of switching frequency.....	32
6.	CABLING AND CONNECTIONS	33
6.1	Power unit.....	33
6.1.1	Power connections.....	34
6.1.1.1	DC supply and motor cables.....	34
6.1.1.2	Control cable.....	34
6.1.1.3	Fuses, NXI_xxxx 5.....	35

6.1.1.4	Fuses, NXI_xxxx 6.....	35
6.1.1.5	Cable sizes, NXI_xxxx 5.....	36
6.1.1.6	Cable sizes, NXI_xxxx 6.....	36
6.1.2	Installation instructions	37
6.1.2.1	Stripping lengths of motor and DC supply cables.....	39
6.1.2.2	VACON® NX enclosures.....	40
6.1.3	Cable installation and the UL standards	42
6.1.4	Cable and motor insulation checks	42
6.2	Control unit	43
6.2.1	Control voltage (+24V/EXT +24V).....	43
6.2.2	Control connections	44
6.2.2.1	Control cables	46
6.2.2.2	Galvanic isolation barriers.....	46
6.2.3	Control terminal signals	47
6.2.3.1	Digital input signal inversions.....	48
6.2.3.2	Jumper selections on the NXOPTA1 basic board.....	49
7.	CONTROL KEYPAD	51
7.1	Indicators on the keypad display.....	51
7.1.1	Drive status indications.....	51
7.1.2	Control place indicators.....	52
7.1.3	Status LEDs (green – green – red).....	52
7.1.4	Text lines.....	53
7.2	Keypad push-buttons.....	54
7.2.1	Button descriptions	54
7.3	Navigation on the control keypad.....	55
7.3.1	Monitoring menu (M1)	57
7.3.2	Parameter menu (M2)	58
7.3.3	Keypad control menu (M3)	60
7.3.3.1	Selection of control place	60
7.3.3.2	Keypad reference	60
7.3.3.3	Keypad direction.....	60
7.3.3.4	Stop button activated.....	61
7.3.4	Active faults menu (M4).....	62
7.3.4.1	Fault types	62
7.3.4.2	Fault codes	64
7.3.4.3	Fault time data record.....	67
7.3.5	Fault history menu (M5)	68
7.3.6	System menu (M6).....	69
7.3.6.1	Selection of language.....	72
7.3.6.2	Application selection	72
7.3.6.3	Copy parameters	73
7.3.6.4	Parameter comparison	75
7.3.6.5	Safety	76
7.3.6.6	Keypad settings	78
7.3.6.7	Hardware settings.....	80
7.3.6.8	System info	82
7.3.7	Expander board menu (M7).....	86
7.4	Further keypad functions	87
8.	COMMISSIONING.....	88
8.1	Safety.....	88

8.2	Commissioning the inverter	88
9.	FAULT TRACING.....	91

1. SAFETY



ONLY A COMPETENT ELECTRICIAN MAY CARRY OUT
THE ELECTRICAL INSTALLATION



1.1 Warnings

 WARNING	1	The components of the power unit of the inverter are live when the VACON® NX is connected to DC supply. Coming into contact with this voltage is extremely dangerous and may cause death or severe injury. The control unit is isolated from mains potential.
	2	The supply and motor terminals are live when the VACON® NX is connected to DC supply, even if the motor is not running.
	3	The control I/O-terminals are isolated from the mains potential. However, the relay outputs and other I/O-terminals may have dangerous control voltage present even when the VACON® NX is disconnected from the DC supply.
	4	The inverter has a large capacitive leakage current.
	5	If the inverter is used as a part of a machine, the machine manufacturer is responsible for providing the machine with a main switch (EN 60204-1).
	6	Only spare parts delivered by manufacturer can be used.

1.2 Safety instructions

	1	The VACON® NX inverter is meant for fixed installations only.
	2	Do not perform any measurements when the inverter is connected to the DC supply.
	3	After having disconnected the inverter from the DC supply, wait until the fan stops and the indicators on the keypad go out (if no keypad is attached see the indicator through the keypad base). Wait 5 more minutes before doing any work on VACON® NX connections. Do not even open the cover before this time has expired.
	4	Do not perform any voltage withstand tests on any part of VACON® NX. There is a certain procedure according to which the tests shall be performed. Ignoring this procedure may result in damaged product.
	5	Prior to measurements on the motor or the motor cable, disconnect the motor cable from the inverter.
	6	Do not touch the components on the circuit boards. Static voltage discharge may damage the components.
	7	Before connecting the inverter to DC supply, make sure that the VACON® NX front and cable covers are closed.

1.3 Grounding and earth fault protection

The VACON® NX inverter must always be earthed with a grounding conductor connected to the grounding terminal. 

The earth fault protection inside the inverter only protects the inverter against earth faults in the motor or the motor cable.

Due to the high capacitive currents present in the inverter, fault current protective switches may not function properly. If fault current protective switches are used, they need to be tested with earth fault currents present during possible fault situations.

1.4 Running the motor

Warning symbols

For your own safety, please pay special attention to the instructions marked with the following symbols:

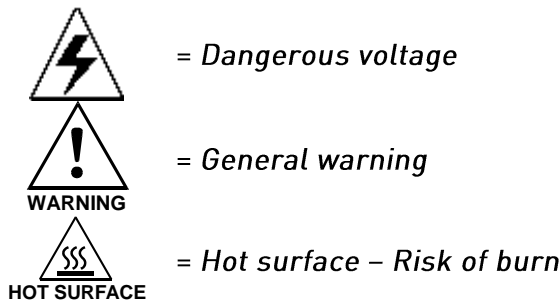

MOTOR RUN CHECK LIST

 WARNING	1	Before starting the motor, check that the motor is mounted properly and ensure that the machine connected to the motor allows the motor to be started.
	2	Set the maximum motor speed (frequency) according to the motor and the machine connected to it.
	3	Before reversing the motor, make sure that this can be done safely.
	4	Make sure that no power correction capacitors are connected to the motor cable.
	5	Make sure that the motor terminals are not connected to mains potential.

NOTE! You can download the English and French product manuals with applicable safety, warning and caution information from <http://drives.danfoss.com/knowledge-center/technical-documentation/>.

REMARQUE Vous pouvez télécharger les versions anglaise et française des manuels produit contenant l'ensemble des informations de sécurité, avertissements et mises en garde applicables sur le site <http://drives.danfoss.com/knowledge-center/technical-documentation/>.

2. EU DIRECTIVE

2.1 CE marking

The CE marking on the product guarantees the free movement of the product within the EEA (European Economic Area). It also guarantees that the product complies with applicable directives (for example, the EMC Directive and other possible so-called new method directives). VACON® NX Inverters carries the CE label as a proof of compliance with the Low Voltage Directive (LVD), Electro Magnetic Compatibility (EMC) Directive and RoHS Directive.

2.2 EMC directive

2.2.1 Introduction

The EMC Directive provides that the electrical apparatus must not excessively disturb the environment it is used in, and, on the other hand, it shall have an adequate level of immunity toward other disturbances from the same environment.

The compliance of VACON® NX inverters with the EMC directive is verified with Technical Construction Files (TCF) and checked and approved by SGS FIMKO, which is a Competent Body. The Technical Construction Files are used to authenticate the conformity of VACON® inverters with the Directive because it is impossible to test such a large product family in a laboratory environment and because the combinations of installation vary greatly.

2.2.2 Technical criteria

Our basic idea was to develop a range of inverters offering the best possible usability and cost-efficiency. EMC compliance was a major consideration from the outset of the design.

VACON® NX inverters are marketed throughout the world, a fact which makes the EMC requirements of customers different. As far as **immunity** is concerned, all VACON® NX inverters are designed to fulfil even the strictest requirements.

2.2.3 VACON® inverter EMC classification

Factory delivered VACON® NX inverters are Class T equipment, which fulfil all EMC immunity requirements (standards EN 50082-1, 50082-2 and EN 61800-3).

Class T:

Class T equipment have a small earth leakage current and can be used with floating DC input. If they are used with other supplies, no EMC requirements are complied with.

Warning: This product is of the restricted sales distribution class according to IEC 61800-3. In residential areas, this product may cause radio interference in which case the user may be required to take adequate measures.

2.2.4 Manufacturer's declaration of conformity

The following page presents the photocopy of the Manufacturer's Declaration of Conformity assuring the compliance of VACON® Inverters with the EMC-directives



Danfoss A/S

DK-1432 Nordborg
Denmark
CVR No. 20285941

Telephone: +45 78 88 44 77
Fax: +45 78 18 98 93

EU DECLARATION OF CONFORMITY

Danfoss A/S

Vacon Ltd

declares under our sole responsibility that the

Product(s) Vacon NX Common DC bus Products

Type(s) Vacon NX: 0004 5... to 2700 5
Vacon NX: 0004 6... to 2250 6
Vacon NXA 0004 5... to 2700 5
Vacon NXA 0004 6... to 2250 6
Vacon NXN 0400 5... to 0650 5
Vacon NXN 0400 6... to 0650 6
Vacon NXB 0004 5... to 2700 5
Vacon NXB 0004 6... to 2250 6

Covered by this declaration is in conformity with the following directive(s), standard(s) or other normative document(s), provided that the product is used in accordance with our instructions.

Safety: EN 61800-5-1:2007
EN 60204-1:2006+A1:2009 (as relevant)

EMC: EN 61800-3:2004+A1:2012

RoHS: EN 50581:2012

and conforms to the relevant safety provisions of Low Voltage Directive 2014/35/EU, EMC Directive 2014/30/EU and RoHS Directive 2011/65/EU.

The year the CE marking was affixed: 2005

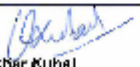
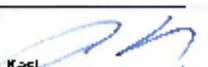
Date: 25 th Oct 2017	Issued by: Signature:  Name: Shakhir Kubaj Title: Head of Premium Drives	Date: 26 th Oct 2017	Approved by: Signature:  Name: Timo Kasi Title: VP, Design Center Finland and Italy
------------------------------------	--	------------------------------------	--

Danfoss only vouches for the correctness of the English version of its declaration. In the event of the declaration being translated into any other language, the translator concerned shall be liable for the correctness of the translation.

Document ID: 00736549 Revision, Sequence: A 1 Creator: Hautaniemi, Mikko #J016693#
File Origin Date: 2017-08-28 File Last Modified: 2017-10-11

3. RECEIPT OF DELIVERY

VACON® NX inverters have undergone scrupulous tests and quality checks at the factory before they are delivered to the customer. However, after unpacking the product, check that no signs of transportation damage is to be found on the product and that the delivery is complete (compare the type designation of the product to the code below, see Figure 3-1

Should the drive have been damaged during the shipping, please contact primarily the cargo insurance company or the carrier.

If the delivery does not correspond to your order, contact the supplier immediately.

3.1 Type designation code.

3.1.1 FR4—FR8

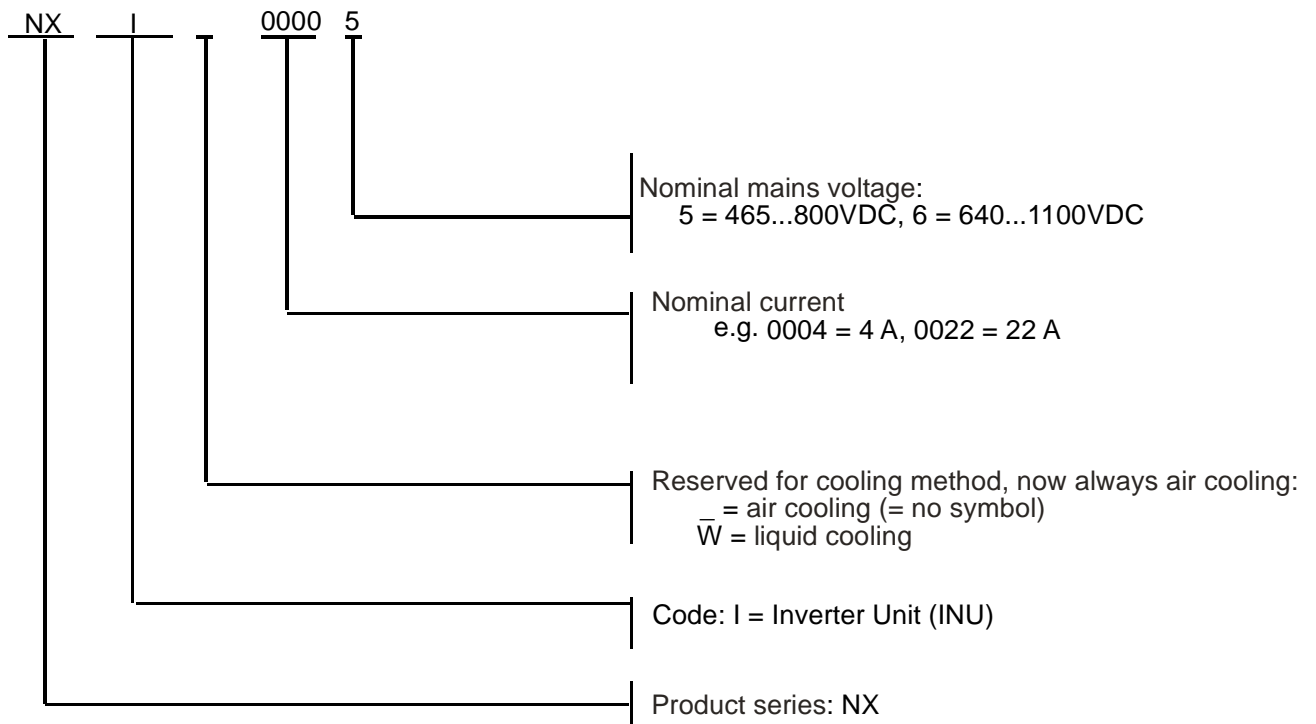

nxik2.fh8

Figure 3-1 VACON® NX type designation code, FR4—FR8

3.1.2 The standard features of VACON® NX inverters

	INU
Sales code	NXI_AAAA 5/6
Standard features FR4, FR6 and FR7	DC connection
	IP21
	Air cooling
	Integrated charging
	Alphanumeric control panel (in the front of the module)
	I/O modules A1 & A2
	Standard board
	Safety CE / UL
Sales code	NXI_AAAA 5/6
Standard features FR8	DC connection
	IP00
	Air cooling
	Integrated charging
	Alphanumeric control panel (in the front of the module)
	I/O modules A1 & A2
	Standard board
	Safety CE / UL

Table 3-1. The standard features of VACON® NX inverters

3.2 Storage

If VACON® NX Inverter is to be stored before use, make sure that the ambient conditions are acceptable:

Storage temperature: $-40...+70$ °C ($-40...+158$ °F)

Relative humidity: 0 to 95%, no condensation

If you must keep the VACON® NX Active Front End in storage for a long time, you must connect the power to the VACON® NX Active Front End each year. Keep the power on for a minimum of 2 hours. We do not recommend a long storage time. If the storage time is more than 12 months, you must charge the electrolytic DC capacitors with caution. To reform the capacitors, obey the instructions in Chapter 3.2.1 Capacitor reforming.

3.2.1 Capacitor reforming

After a long storage time, it is necessary to reform the capacitors to prevent damage to the capacitors. To make sure that the possible high leakage current through the capacitors stays in minimum, use a DC-power supply with an adjustable current limit.

1. Set the current limit to 300-800mA to agree with the size of the drive.
2. Connect the DC-power supply to the B+/Bterminals (DC+ to B+, DC- to B-) of the DC-link or directly to the capacitor terminals.
3. Set the DC-voltage to the nominal DC-voltage level of the Active Front End ($1.35 \cdot U_n$ AC) and keep the power on for 1 hour, at minimum. If the Active Front End was in store for much longer than 12 months and the capacitors were not charged, speak to the factory to get instructions before you connect the power.

3.3 Maintenance

All technical devices, drives as well, need a certain amount of care-taking and failure preventive maintenance. To maintain trouble-free operation of the drive, environmental conditions, as well as load, line power, process control, etc. have to be within specifications, determined by manufacturer.

If all conditions are in accordance with the manufacturer's specifications, there are no other concerns, but to provide a cooling capacity high enough for the power- and control circuits. This requirement can be met by making sure, that the cooling system works properly. Operation of cooling fans and cleanness of the heat sink should be verified regularly.

Regular maintenance is recommended to ensure trouble free operation and long lifetime of the drive. At least the issues listed in the following table should be included in the regular maintenance.

Interval	Maintenance
12 months (if unit stored)	Capacitor reforming, see Chapter 3.2.1
6 - 24 months (The interval is different in different environment.)	<p>Check tightening torque of the input and output terminals and I/O terminals.</p> <p>Clean the heat sink.</p> <p>Clean the cooling tunnel.</p> <p>Check operation of the cooling fan, check for corrosion on terminals, bus bars and other surfaces.</p> <p>Check the door filters.</p>
5 - 7 years	<p>Change the cooling fans.</p> <ul style="list-style-type: none"> • Main fan of the unit. • Fan of the LCL filter. • Internal IP54 (UL Type 12) fan. • Cabinet cooling fan/filter.
5 - 10 years	Change the DC bus capacitors if DC voltage ripple is high.

Table 3-2. Maintenance table

It is also recommended to record all actions and counter values with dates and time for follow up of maintenance.

3.4 Disposal

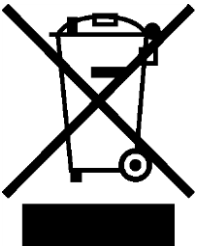
	<p>When the drive is at the end of its operation life, do not discard it as a part of municipal waste. You can recycle the primary components of the drive. You must disassemble some components before you can remove the different materials. Recycle the electrical and electronic components as waste.</p> <p>To make sure that the waste is recycled correctly, send the waste to a recycling centre. You can also send the waste back to the manufacturer. Obey the local and other applicable regulations.</p>
---	---

4. TECHNICAL DATA

4.1 Introduction

The figure below presents the block diagram of the VACON[®] NX inverter. The inverter mechanically consists of two units, the Power Unit and the Control Unit.

The Power Unit contains an inverter bridge which consists of IGBT switches and produces a symmetrical, 3-phase PWM-modulated AC voltage to the motor. To protect the DC-link capacitors, the Power Unit also contains a charging circuit for controlled DC-link charge. Use the B+ and DC- terminals in order to bypass the charging circuit.

The Motor and Application Control Block is based on microprocessor software. The microprocessor controls the motor based on the information it receives through measurements, parameter settings, control I/O and control keypad. The motor and application control block controls the motor control ASIC which, in turn, calculates the IGBT positions. Gate drivers amplify these signals for driving the IGBT inverter bridge.

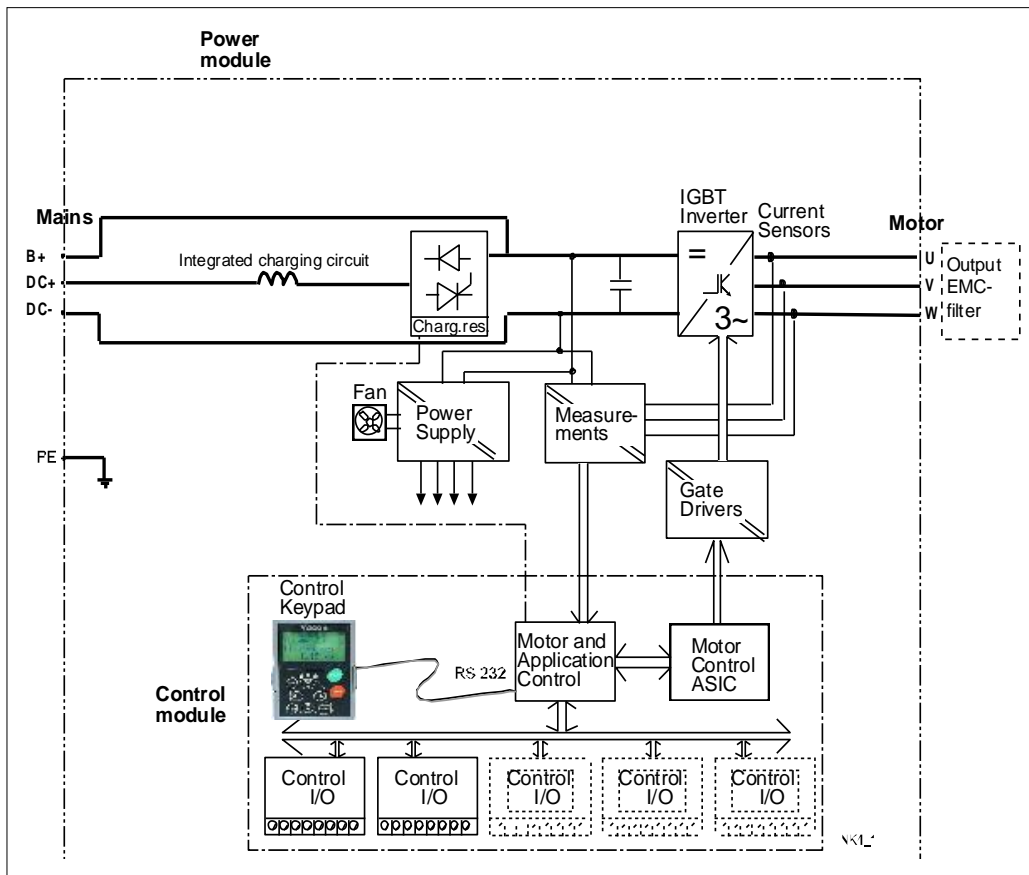

Figure 4-1. The block diagram of VACON[®] NX inverter

The control keypad constitutes a link between the user and the inverter. The control keypad is used for parameter setting, reading status data and giving control commands. It is detachable and can be operated externally and is connected via a cable to the inverter. Instead of the control keypad, a PC can be used to control the inverter if connected through a similar cable (VACON RS232PC -1.5M).

The basic control interface and the parameters (the Basic Application) are easy to use. If a more versatile interface or parameters are required, a more suitable application can be chosen from the "All in One+" Application Package. See the "All in One+" Application Manual for more information on the different applications.

Optional I/O expander boards that increase the number of inputs and outputs to be used are also available. For more information, contact the Manufacturer or your local distributor (see back cover).

4.2 Power ratings

4.2.1 Supply voltage 465-800 Vdc, Motor voltage 380—500 Vac

Enclosure sizes FR4...7 are available as IP21 and FR8 as IP 00

Motor voltage 380-500 Vac, 50/60 Hz, 3~											
Inverter type	Loadability @ 40 °C ambient temperature					Motor shaft power				Enclosure size	Dimensions and weight WxHxD/kg
	Low		High		Max current I _s	513Vdc supply		675Vdc supply			
	Rated continuous current I _L (A)	10% overload current (A)	Rated continuous current I _H (A)	50% overload current (A)		10% overload 40°C P(kW)	50% overload 50°C P(kW)	10% overload 40°C P(kW)	50% overload 50°C P(kW)		
NXI_0004 5	4.3	4.7	3.3	5	6.2	1.5	1.1	2.2	1.5	FR4	128x292x190/5
NXI_0009 5	9	9.9	7.6	11.4	14	4	3	5.5	4	FR4	128x292x190/5
NXI_0012 5	12	13.2	9	13.5	18	5.5	4	7.5	5.5	FR4	128x292x190/5
NXI_0016 5	16	17.6	12	18	24	7.5	5.5	11	7.5	FR6	195x519x237/16
NXI_0022 5	23	25.3	16	24	32	11	7.5	15	11	FR6	195x519x237/16
NXI_0031 5	31	34	23	35	46	15	11	18.5	15	FR6	195x519x237/16
NXI_0038 5	38	42	31	47	62	18.5	15	22	18.5	FR6	195x519x237/16
NXI_0045 5	46	51	38	57	76	22	18.5	30	22	FR6	195x519x237/16
NXI_0061 5	61	67	46	69	92	30	22	37	30	FR7	237x591x257/29
NXI_0072 5	72	79	61	92	122	37	30	45	37	FR7	237x591x257/29
NXI_0087 5	87	96	72	108	144	45	37	55	45	FR7	237x591x257/29
NXI_0105 5	105	116	87	131	174	55	45	75	55	FR7	237x591x257/29
NXI_0140 5	140	154	105	158	210	75	55	90	75	FR8	285x721x288/48

Table 4-1. Power ratings and dimensions of VACON® NX, supply voltage 465—800Vdc

Note: The rated currents in given ambient temperatures are achieved only when the switching frequency is equal to or less than the factory default.

4.2.2 Supply voltage 640-1100 Vdc, Motor voltage 525—690 Vac

Enclosure sizes FR4...7 are available as IP21 and FR8 as IP 00

Motor voltage 525-690 Vac, 50/60 Hz, 3~									
Inverter type	Loadability @ 40 °C ambient temperature					Motor shaft power		Enclosure size	Dimensions and weight WxHxD/kg
	Low		High		Max current I_s	930Vdc supply			
	Rated continuous current I_L (A)	10% overload current (A)	Rated continuous current I_H (A)	50% overload current (A)		10% overload 40°C P(kW)	50% overload 50°C P(kW)		
NXI_0004 6	4.5	5	3.2	5	6.7	3	2.2	FR6	195x519x237/16
NXI_0005 6	5.5	6.1	4.5	6.8	9	4	3	FR6	195x519x237/16
NXI_0007 6	7.5	8.3	5.5	8.3	11	5.5	4	FR6	195x519x237/16
NXI_0010 6	10	11	7.5	11.3	15	7.5	5.5	FR6	195x519x237/16
NXI_0013 6	13.5	14.9	10	15	20	11	7.5	FR6	195x519x237/16
NXI_0018 6	18	19.8	13.5	20.3	27	15	11	FR6	195x519x237/16
NXI_0022 6	22	24.2	18	27	36	18.5	15	FR6	195x519x237/16
NXI_0027 6	27	29.7	22	33	44	22	18.5	FR6	195x519x237/16
NXI_0034 6	34	37	27	41	54	30	22	FR6	195x519x237/16
NXI_0041 6	41	45	34	51	68	37.5	30	FR7	237x591x257/29
NXI_0052 6	52	57	41	62	82	45	37.5	FR7	237x591x257/29
NXI_0062 6	62	68	52	78	104	55	45	FR8	285x721x288/48
NXI_0080 6	80	88	62	93	124	75	55	FR8	285x721x288/48
NXI_0100 6	100	110	80	120	160	90	75	FR8	285x721x288/48

Table 4-2. Power ratings and dimensions of VACON® NX, supply voltage 640—1100Vdc

Note: The rated currents in given ambient temperatures are achieved only when the switching frequency is equal to or less than the factory default.

4.2.3 Overload capability

The low overload means that if 110% of the continuous current (I_L) is required for 1 minute every 10 minutes, the remaining 9 minutes must be approximately 98% of I_L or less. This is to make sure that the output current is not more than I_L during the duty cycle.

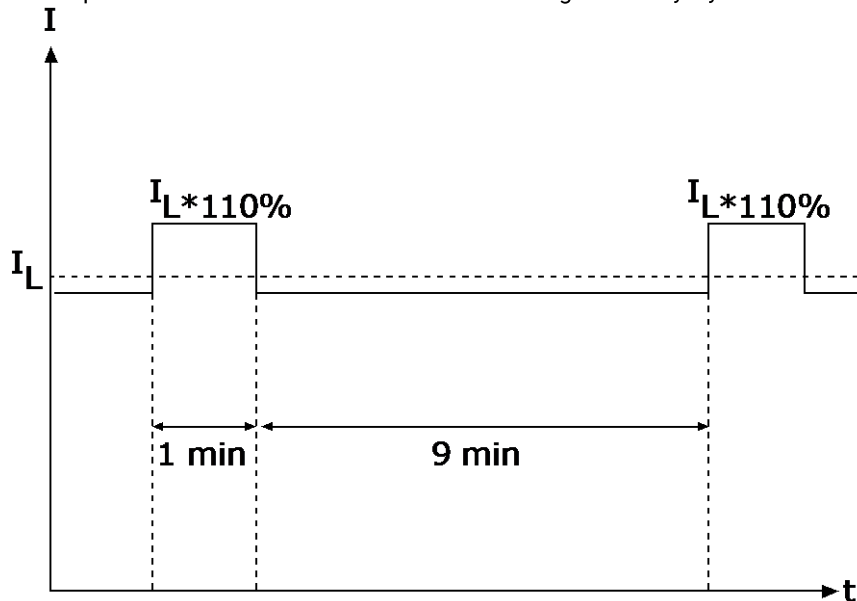

Figure 4-2. Low overload

The high overload means that if 150% of the continuous current (I_H) is required for 1 minute every 10 minutes, the remaining 9 minutes must be approximately 92% of I_H or less. This is to make sure that the output current is not more than I_H during the duty cycle.

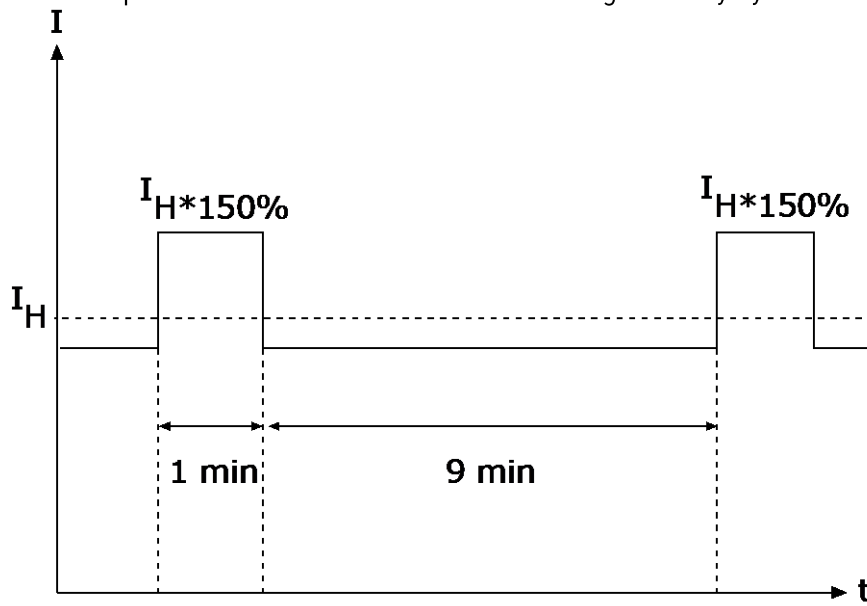

Figure 4-3. High overload

4.3 Technical information

DC connection	Input voltage U_{in}	465...800Vdc; 640...1100Vdc; -0%...+0% , the ripple voltage of the inverter supply voltage generated during the rectification of the fundamental frequency AC voltage must be less than 50Vp-p.
	Connection to DC supply	Once per minute or less (normal)
	Starting delay	FR4-FR8: 2 s
Motor connection	Output voltage	$3 \sim 0 - U_{in} / 1.4$
	Continuous output current	I_H : Ambient temperature max. +50°C (+122°F), overload 1.5 x I_H (1 min./10 min.) I_L : Ambient temperature max. +40°C (+104°F), overload 1.1 x I_L (1 min./10 min.)
	Starting torque	I_S for two seconds, depends on the motor
	Starting current	I_S for 2 s every 20 s
	Output frequency	0...320 Hz; 7200 Hz (special use)
	Frequency resolution	Depends on application
	Control characteristics	Control method
Switching frequency (see parameter 2.6.9)		NXI_xxxx 5 : 1...16 kHz; Factory default 10 kHz NXI_0072 and greater: 1...10 kHz; Factory default 3.6 kHz NXI_xxxx 6 : 1...6 kHz; Factory default 1.5 kHz
<u>Frequency reference</u> Analogue input Panel reference		Resolution 0.1% (10-bit), accuracy ±1% Resolution 0.01 Hz
Field weakening point		30...320 Hz
Acceleration time		0...3000 sec
Deceleration time		0...3000 sec
Ambient conditions		Ambient operating temperature
	Storage temperature	-40 °C (-40 °F)...+70 °C (158 °F)
	Relative humidity	0 to 95% RH, non-condensing, non-corrosive, no dripping water
	Air quality: - chemical vapours - mechanical particles	IEC 60721-3-3, unit in operation, class 3C2 IEC 60721-3-3, unit in operation, class 3S2
	Altitude	100% load capacity (no derating) up to 1,000 m 1-% derating for each 100m above 1000.; max. 3000m
	Vibration IEC/EN 60068-2-6 IEC/EN 61800-5-1	5-150 Hz Displacement amplitude 1 mm (peak) at 5-15.8 Hz Maximum acceleration amplitude 1 G at 15.8-150 Hz
	Shock EN50178, EN60068-2-27	UPS Drop Test (for applicable UPS weights) Storage and shipping: max. 15 G, 11 ms (in package)
	Enclosure class	FR4...7 IP21/NEMA1 standard FR8 IP00 standard/Open type standard size in the kW/HP range
	EMC (at default settings)	Immunity IEC/EN 61800-3
Safety standards	IEC/EN 61800-5-1, UL 508C, CSA C22.2 No.274	

Approvals		CE, cULus, RCM, KC, EAC, UA (see nameplate of the drive for more approvals.) Marine approvals: LR, BV, DNV, GL, ABS, RMRS, CCS, KR
Control connections	Analogue input voltage	0...+10V, $R_i = 200k\Omega$, [-10V...+10V joystick control] Resolution 0.1%, accuracy $\pm 1\%$
	Analogue input current	0(4)...20 mA, $R_i = 250\Omega$ differential
	Digital inputs (6)	Positive or negative logic; 18...30VDC
	Auxiliary voltage	+24V, $\pm 15\%$, max. 250mA
	Output reference voltage	+10V, +3%, max. load 10mA
	Analogue output	0(4)...20mA; R_L max. 500 Ω ; Resolution 10bit; Accuracy $\pm 2\%$
	Digital outputs	Open collector output, 50mA/48V
	Relay outputs	2 programmable change-over relay outputs Switching capacity 24VDC/8A, 250VAC/8A, 125VDC/0.4A Min.switching load: 5V/10mA
Protections	Overvoltage trip limit	NXI_5: 911VDC; NXI_6: 1200VDC
	Undervoltage trip limit	NXI_5: 333VDC; NXI_6: 460 VDC
	Earth fault protection	In case of earth fault in motor or motor cable, only the inverter is protected
	Output phase supervision	Trips if any of the output phases is missing
	Overcurrent protection	Yes. * The motor overload protection activates at 110% of the full load current.
	Unit overtemperature protection	Yes
	Motor overload protection	Yes
	Motor stall protection	Yes
	Motor underload protection	Yes
	Short-circuit protection of +24V and +10V reference voltages	Yes

Table 4-3. Technical information

* For the motor thermal memory and the memory retention function to obey the UL 508C requirements, you must use the system software version NXS00001V175, NXS00002V177 or NXP00002V186 or a newer version. If you use an older system software version, you must install a motor overtemperature protection to comply with the UL regulations.

Structure	Inom (output)	Motor cos	Idc (input)
FR4	4.3	0.79	4.4
	9	0.82	9.6
	12	0.83	1.0
FR6	16	0.84	17.5
	22	0.85	24.4
	31	0.85	34.3
	38	0.86	43
	45	0.86	50
FR7	61	0.86	68
	72	0.87	82
	87	0.87	99
	105	0.87	119
FR8	140	0.88	160

Table 4- 4 DC currents of VACON®NX, supply voltage 465 - 800Vdc

Structure	Inom (output)	Motor cos	Idc (input)
FR6	4.5	0.81	4.7
	5.5	0.82	5.9
	7.5	0.83	8.1
	10.0	0.84	10.9
	13.5	0.85	14.9
	18.0	0.85	19.9
	22.0	0.86	24.6
	27.0	0.86	30.2
	34.0	0.86	38.1
FR7	41.0	0.87	46
	52.0	0.87	59
FR8	62.0	0.87	70
	80.0	0.88	92
	100.0	0.88	115

Table 4- 5. DC currents of VACON® NX, supply voltage 640 - 1100Vdc

Structure	NXI_xxxx 5 / μ F	NXI_xxxx 6 / μ F
FR4 0003-0007	165	
FR4 0009-0012	235	
FR6	1000	500
FR7	1650	900
FR8	3300	1800

Table 4- 6.. DC-link capacitance by structure.

4.4 Derating

The output power has to be derated if one of following cases:

- Ambient temperature is more than 40 °C (104 °F).
- Installation altitude is more than 1000 m.

4.4.1 Ambient temperature

The power rating of the Active Front End unit is valid for an ambient temperature of 40 °C (104 °F). If the device is to be used in higher ambient temperatures, its power rating must be subjected to derating. The derating coefficient from 40 °C to 50 °C, use derating factor 1.5 %/1 °C, and from 50 °C to 55 °C, use derating factor 2.5 %/1 °C, for ambient temperatures not exceeding 55 °C (131 °F). The reduced power is calculated using the formula:

$$P_{de} = P_n * ((100\% - (t - 40\text{ °C}) * X) / 100)$$

P_n = nominal power of the unit

t = ambient temperature

x = derating coefficient

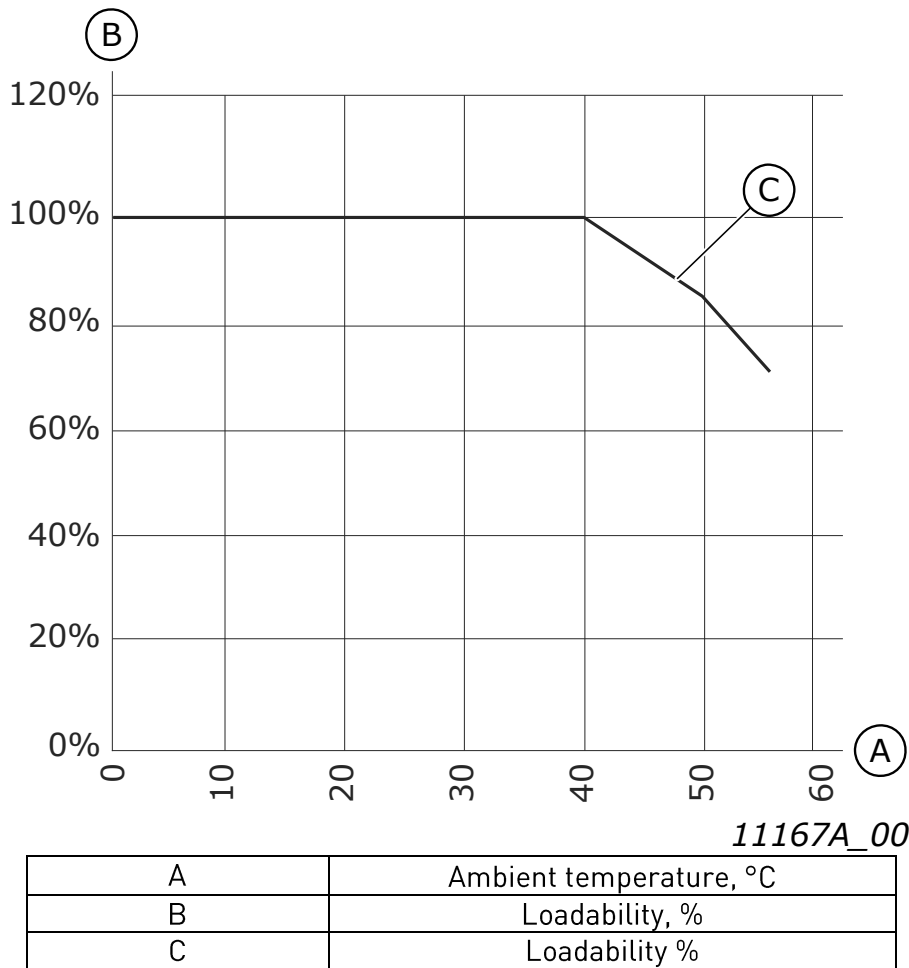

Figure 4-4. Derating as the ambient temperature

4.4.2 High altitude installation

The density of air decreases when the altitude increases and the pressure decreases. When the air density decreases, the thermal capacity decreases (i.e. less air removes less heat) and the resistance to electric field (breakdown voltage / distance) decreases.

The full thermal performance of VACON® NX AC drives is designed for installation up to 1000 m altitude and the electric insulation is designed for installations up to 2000 m altitude. Higher installation locations are possible, when you obey the derating guidelines in this chapter.

NOTE! 690V units maximum installation altitude is 2000m.

Above 1000 m, you must decrease the limited maximum load current by 1% for each 100 m. Thus, for example, at 2500 m altitude, you must decrease the load current down to 85% of the rated output current (100% - (2500 m - 1000 m) / 100 m x 1% = 85%).

When you use fuses at high altitudes, the cooling effect of the fuse decreases as the density of the atmosphere decreases.

When you use fuses above 2000 meters, the continuous rating of the fuse:

$$I = I_n * (1 - (h - 2000) / 100 * 0.5 / 100)$$

I = Current rating at high altitude

I_n = Rated current of a fuse

h = Altitude in meters

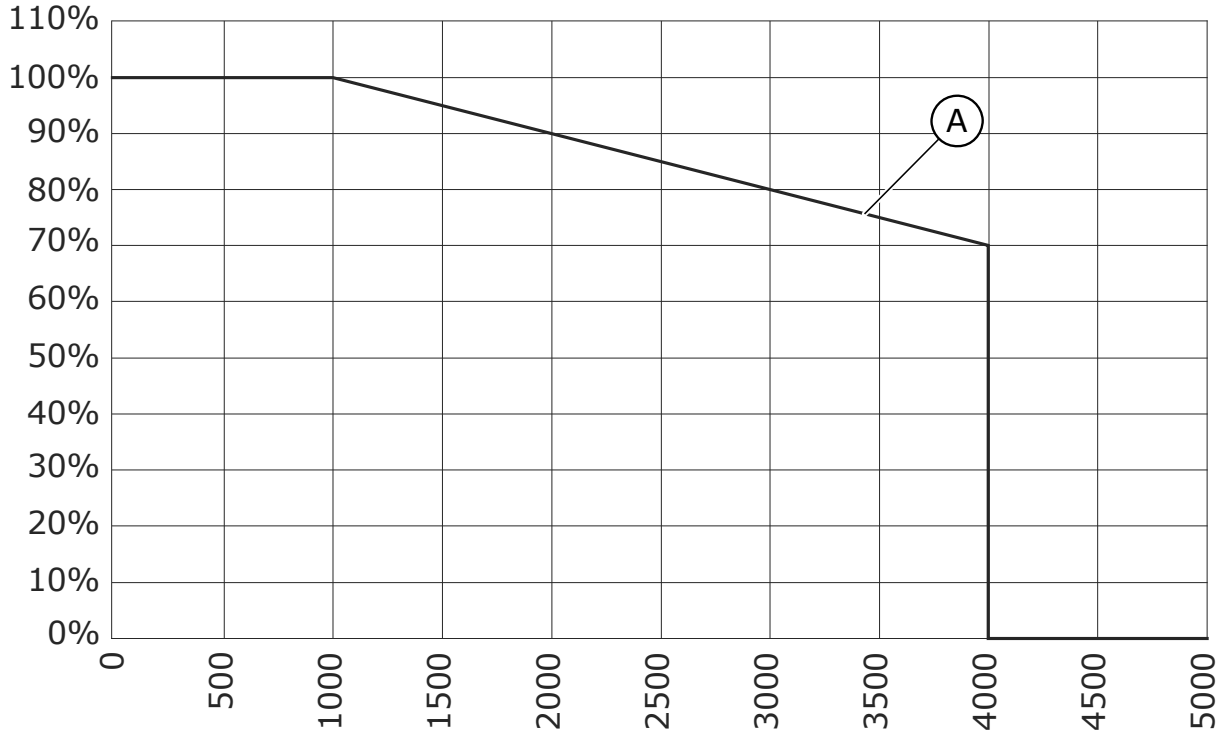

Figure 4-5. Loadability in high altitudes

For permitted maximum altitudes, see Table 4-3.

For information on option boards and I/O signals and relay outputs, see VACON® NX I/O Boards User Manual.

5. INSTALLATION

5.1 Mounting

The inverter can be mounted in either a vertical or horizontal position on a wall or on the back plane of a cubicle. Enough space must be reserved around the inverter to ensure sufficient cooling, see Figure 5-6. You must follow the minimum dimensions for installation, see Table 5-6 and Table 5-7. Also make sure that the mounting plane is relatively even.

The inverter is fixed with four screws (or bolts, depending on the unit size). The dimensions for installation are presented in Figure 5-6 and Table 5-6.

Lift units bigger than FR7 out of the package using a jib crane. Ask the factory or your local distributor for information on how to lift the unit safely.

The following pages show the dimensions for VACON® NX with a default enclosure in Figure 5-1, and with flange mounting in Figures 5-2 and Figure 5-4. Dimensions for the opening needed in flange mounting are given in Table 5-3 and Table 5-5.

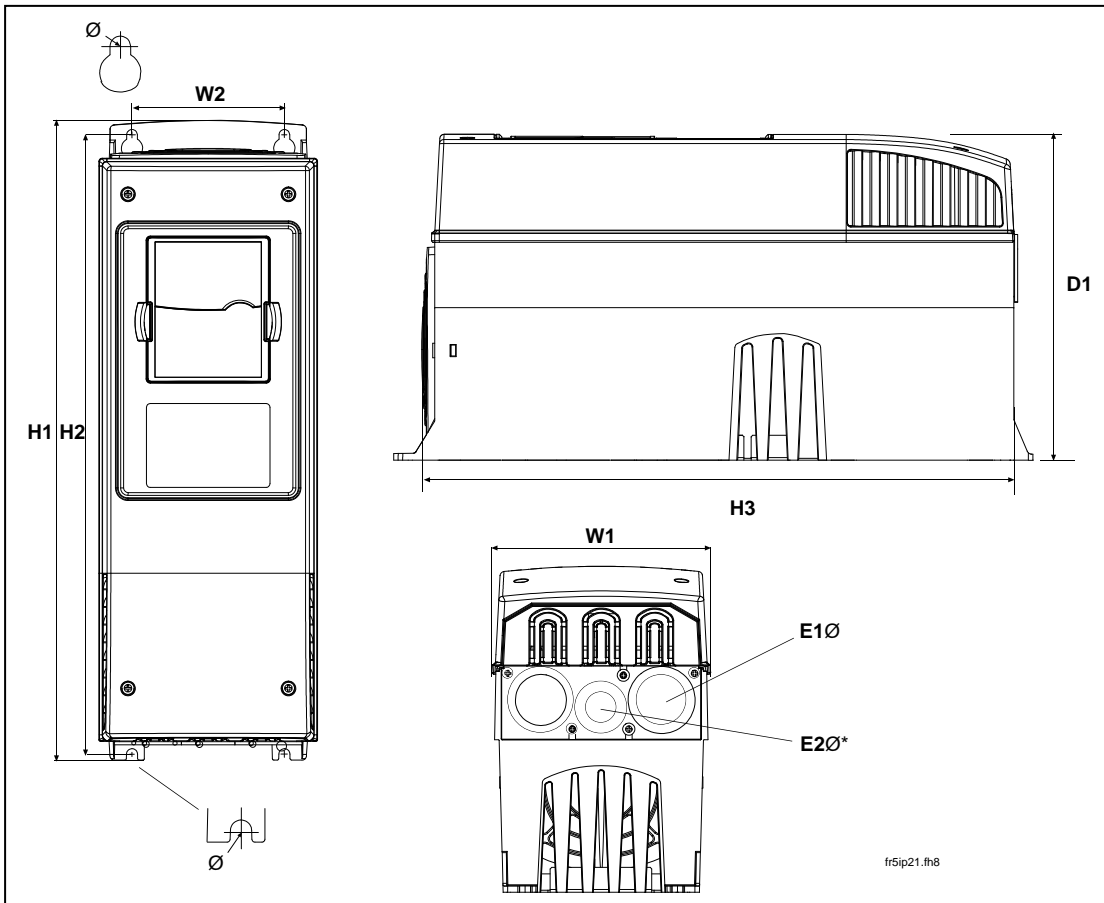

Figure 5-1. The dimensions of VACON® NX, IP21

Type	Dimensions [mm]							
	W1	W2	H1	H2	H3	D1	Ø	E1Ø
NXI_0004—0012 5	128	100	327	313	292	190	7	3 x 28.3
NXI_0016—0045 5 NXI_0004—0034 6	195	148	558	541	519	237	9	3 x 37
NXI_0061—0105 5 NXI_0041—0052 6	237	190	630	614	591	257	9	3 x 47
NXI_0140 5 NXI_0062—0100 6	285	255	755	732	721	312	9	3 x 59

Table 5-1. Dimensions for different inverter types, IP21

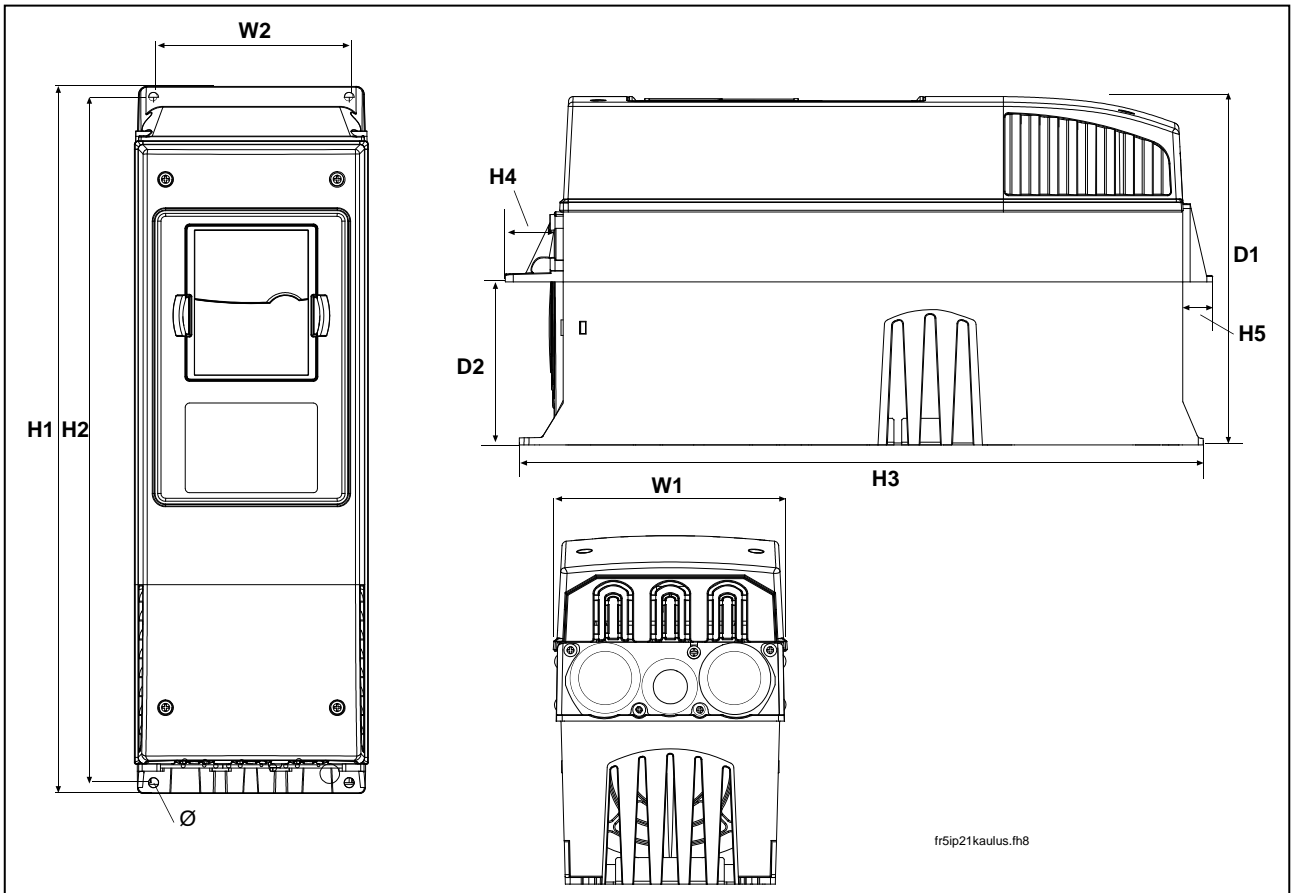

Figure 5-2. VACON® NX dimensions, IP21 with flange, FR4 and FR6

Type	Dimensions [mm]									
	W1	W2	H1	H2	H3	H4	H5	D1	D2	Ø
NXI_0004—0012 5	128	113	337	325	327	30	22	190	77	7
NXI_0016—0045 5 NXI_0004—0034 6	195	170	560	549	558	30	20	237	106	6.5

Table 5-2. Dimensions for inverter types FR4 and FR6, IP21 with flange

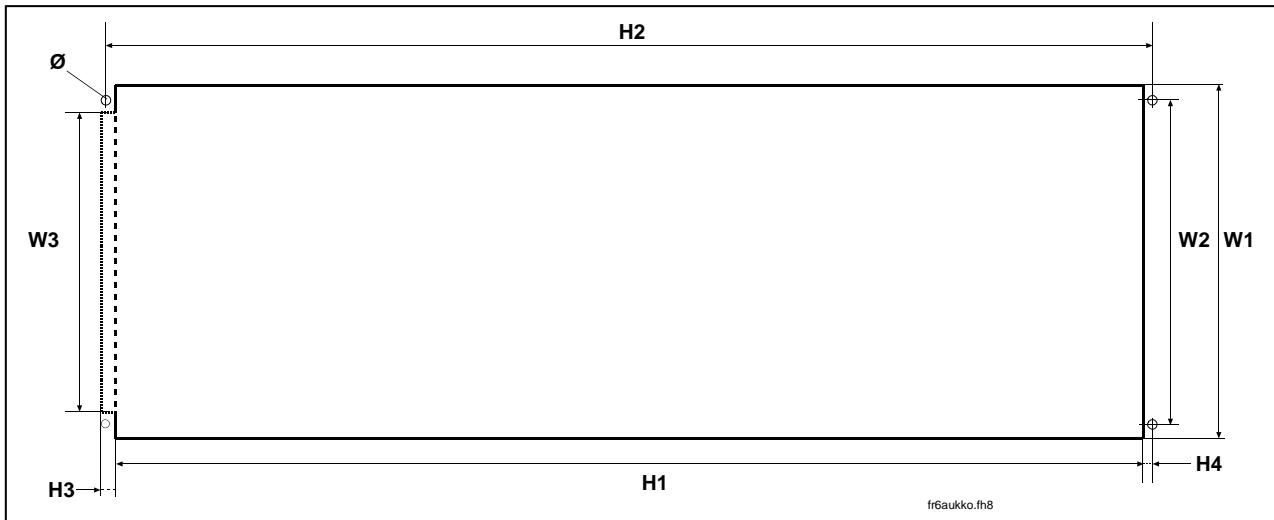

Figure 5-3. The opening needed for flange mounting, FR4 and FR6

Type	Dimensions [mm]							
	W1	W2	W3	H1	H2	H3	H4	Ø
NXI_0004—0012 5	123	113	–	315	325	–	5	6.5
NXI_0016—0045 5	185	170	157	539	549	7	5	6.5
NXI_0004—0034 6								

Table 5-3. Dimensions for the opening for flange mounting, FR4 and FR6

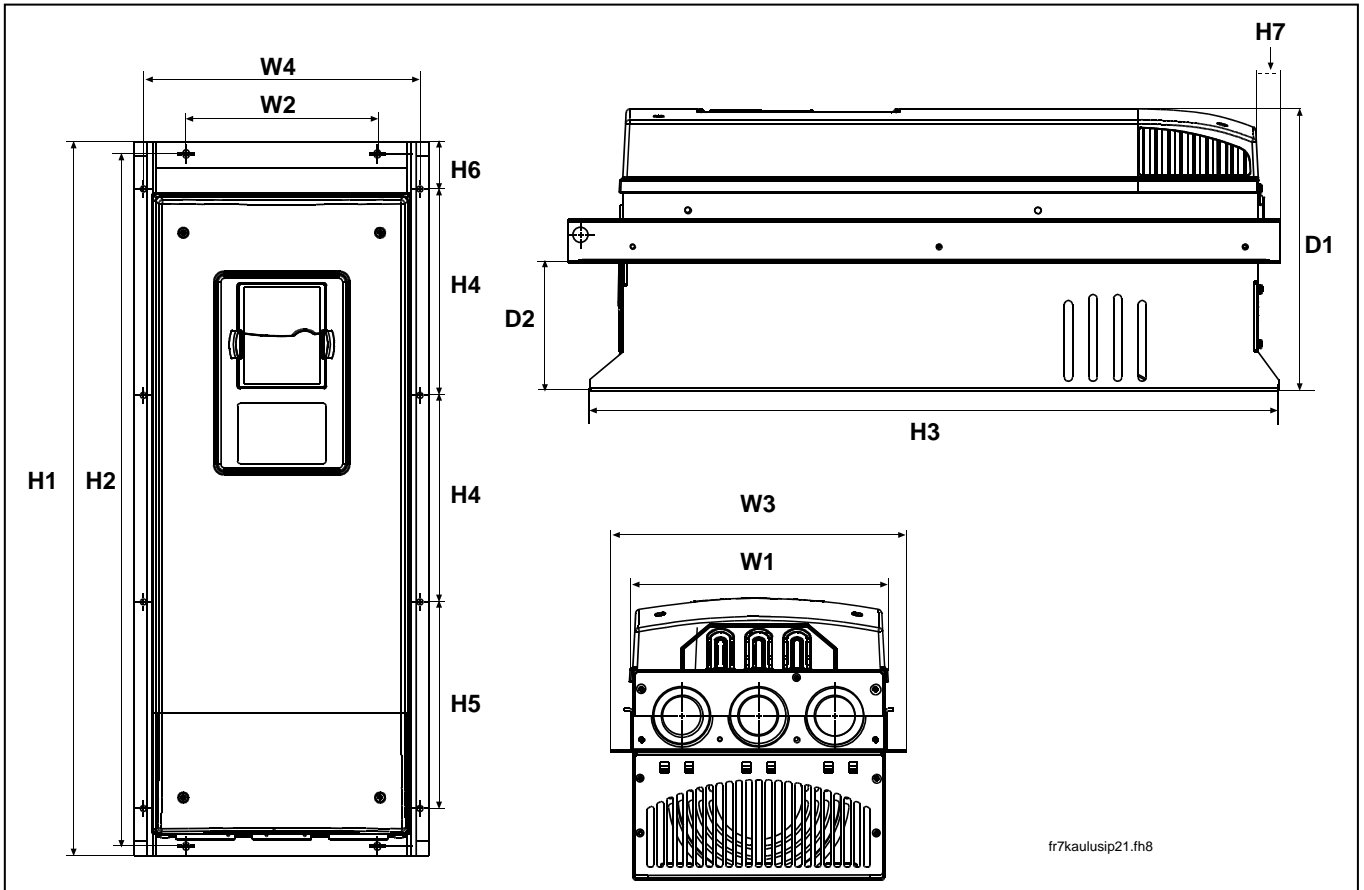

Figure 5-4. VACON® NX dimensions, IP21 with flange, FR4 and FR6

Type	Dimensions [mm]													
	W1	W2	W3	W4	H1	H2	H3	H4	H5	H6	H7	D1	D2	Ø
NXI_0061—0105 5 NXI_0041—0052 6	237	175	270	253	652	632	630	188.5	188.5	23	20	257	117	5.5
NXI_0140 5 NXI_0062—0100 6	285	-	355	330	755	-	745	258	265	43	57	288	110	9

Table 5-4. Dimensions for inverter types FR7 and FR8, IP21 with flange

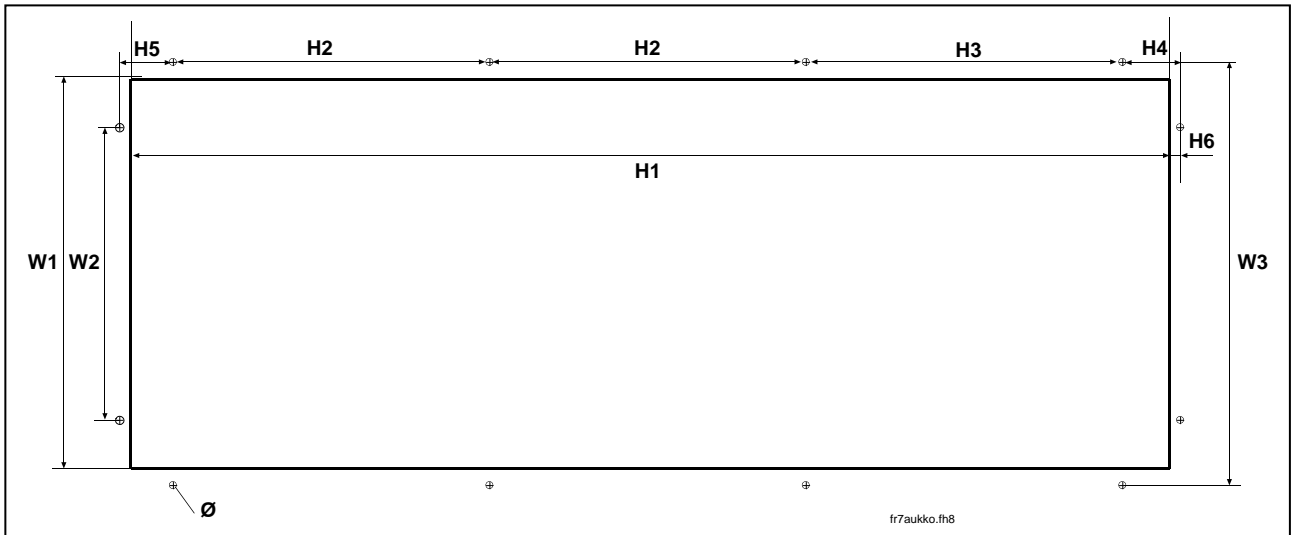

Figure 5-5. The opening needed for flange mounting, FR7/FR8

Type	Dimensions [mm]									
	W1	W2	W3	H1	H2	H3	H4	H5	H6	Ø
NXI_50061—0105 NXI_0041—0052 6	233	175	253	619	188.5	188.5	34.5	32	7	5.5
NXI_0140 5 NXI_0062—0100 6	301	-	330	810	258	265	-	-	-	9

Table 5-5. Dimensions for the opening for flange mounting, FR7/FR8

5.2 Fan cooling

5.2.1 Enclosure sizes FR4 to FR8

Enough free space must be left around the inverter to ensure sufficient air circulation and cooling. You will find the required dimensions for free space in the table below.

If several units are mounted on top of each other, the required free space equals C + D (see figure below). Moreover, the outlet air used for cooling by the lower unit must be directed away from the air intake of the upper unit. When planning the cooling for the space, take into consideration that the inverter's heat loss is 2.5% of the nominal capacity.

Type	Dimensions [mm]				
	A	A ₂	B	C	D
NXI_0004—0012 5	20		20	100	50
NXI_0016—0048 5	30		20	160	80
NXI_0004—0034 6					
NXI_0061—0105 5	80		80	300	100
NXI_0041—0052 6					
NXI_01405	80	150	80	300	200
NXI_0062—0100 6					

Table 5-6. Mounting space dimensions

- A = clearance around the inverter (see also A₂ and B)
- A₂ = clearance needed on either side of the inverter for fan change (without disconnecting the motor cables)
- ** = min. clearance for fan change
- B = distance from one inverter to another or distance to cabinet wall
- C = free space above the inverter
- D = free space underneath the inverter

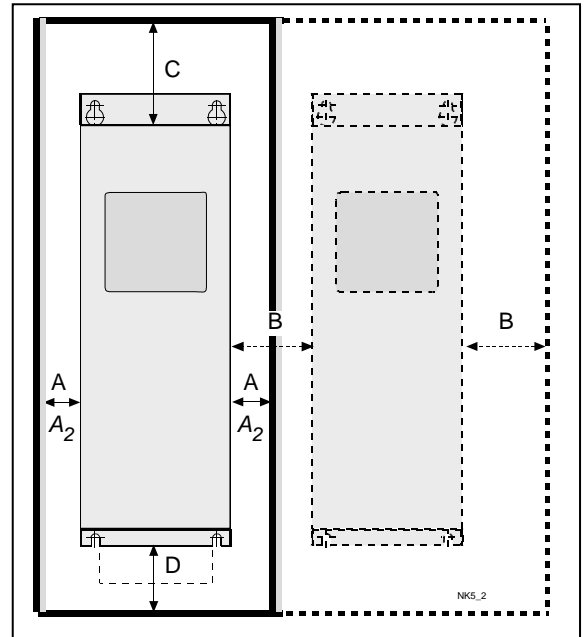

Figure 5-6. Installation space

Type	Greatest possible heat loss (kW)	Cooling air required [m ³ /h]
NXI_0004—0012 5	0.2	70
NXI_0016—0048 5	1	425
NXI_0004—0034 6	0.75	425
NXI_0061—0105 5	1.9	425
NXI_0041—0052 6	1.2	425
NXI_01405	3.3	650
NXI_0062—0100 6	2.25	650

Table 5-7. Required cooling air

5.2.2 Power losses as function of switching frequency

Raising the switching frequency of the drive, to reduce motor noise for example, inevitably affects the power losses and cooling requirements as shown in the Figure below. It illustrates the power loss FR7 as function of switching frequency. For more information, contact the Manufacturer or your local distributor (see back cover).

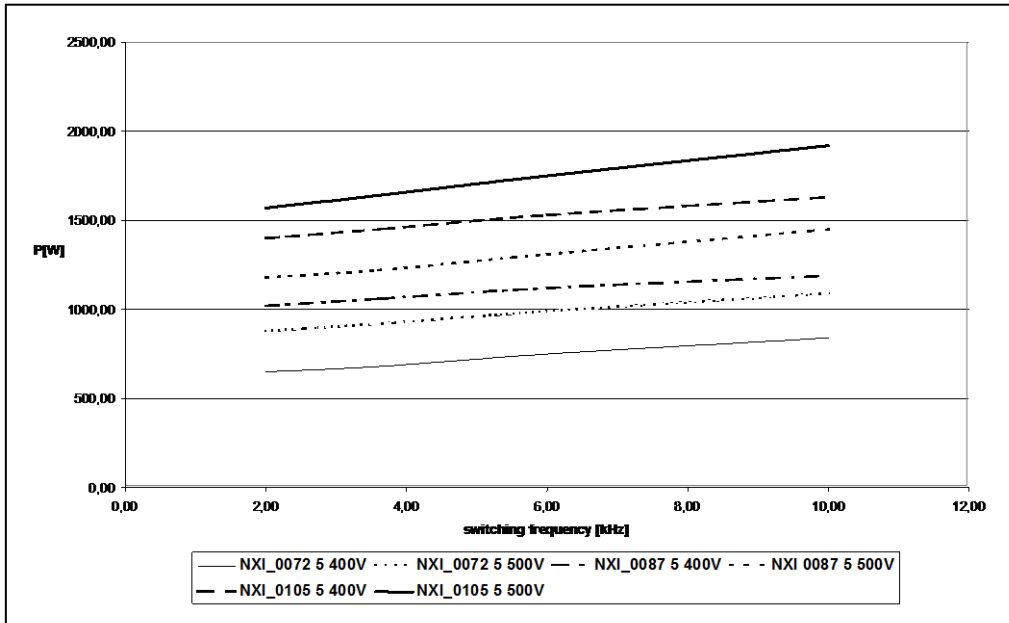

Figure 5-7. Power loss as a function of switching frequency; NXI 0061...0105 5

6. CABLING AND CONNECTIONS

6.1 Power unit

The following wiring diagrams show the supply and motor connections.

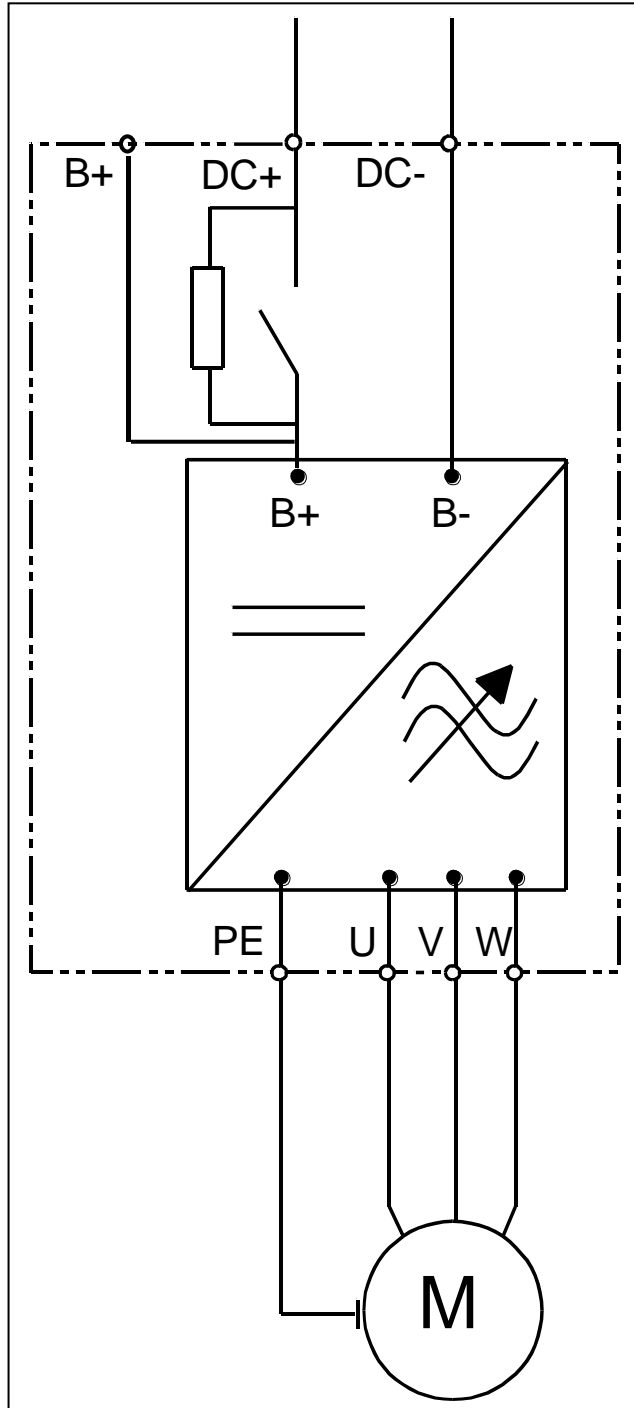

Figure 6-1. The basic wiring diagram

6.1.1 Power connections

6.1.1.1 DC supply and motor cables

The power cables are connected to terminals DC+ and DC- (R+/B+ and DC terminals when using an external charging circuit) and the motor cables to terminals U, V and W. A cable entry gland should be used at the motor cable end to reach the EMC levels, see Table 6-1.

Use cables with a heat resistance of at least +60C. The cables and the fuses must be sized according to the inverter nominal output current which you can find on the rating plate. Installation of cables according to UL regulations is presented in Chapter 6.1.3 and aR fuse sizes in Tables 6-2 and 6-3. The minimum dimensions of the Cu-cables are shown in Table 6-4.

If the motor temperature protection of the drive (see VACON® All in One Application Manual) is used as an overload protection, the cable shall be chosen accordingly. If three or more cables are used in parallel for bigger units, each cable requires a separate overload protection.

These instructions apply only to installations with one motor and one cable connection from the inverter to the motor. In any other case, ask the factory for more information.

Cable type	Level T
Supply cable	Power cable intended for fixed installation and the specific DC voltage. Shielded cable not required. (NKCABLES/MCMK or similar recommended)
Motor cable	Power cable equipped with concentric protection wire and intended for the specific mains voltage. (NKCABLES/MCMK or similar recommended).
Control cable	Screened cable equipped with compact low-impedance shield (NKCABLES/jamak, SAB/ÖZCuY-0 or similar).

Table 6-1. Cable types required to meet standards

6.1.1.2 Control cable

For information on control cables, see Chapter 6.2.2.1 and Table 6-1.

6.1.1.3 Fuses, NXI xxxx 5

Enclosure size	Type	I _L [A]	Bussman aR fuse type	Fuse size	Fuse U _n [V]	Fuse I _n [A]	No. of fuses
FR4	NXI_0004	4.3	170M1560	000	690	20	2
FR4	NXI_0009	9	170M1562	000	690	63	2
FR4	NXI_0012	12	170M1562	000	690	63	2
FR6	NXI_0016	16	170M1565	000	690	63	2
FR6	NXI_0022	22	170M1565	000	690	63	2
FR6	NXI_0031	31	170M1565	000	690	63	2
FR6	NXI_0038	38	170M1567	000	690	100	2
FR6	NXI_0045	45	170M1567	000	690	100	2
FR7	NXI_0061	61	170M1568	000	690	125	2
FR7	NXI_0072	72	170M1570	000	690	200	2
FR7	NXI_0087	87	170M1570	000	690	200	2
FR7	NXI_0105	105	170M1571	000	690	250	2
FR8	NXI_0140	140	170M3819	1	690	400	2

Table 6-2. Fuses used in VACON® NX (465 - 800V)

6.1.1.4 Fuses, NXI xxxx 6

Enclosure size	Type	I _L [A]	Bussman aR fuse type	Fuse size	Fuse U _n [V]	Fuse I _n [A]	No. of fuses
FR6	NXI_0004	4.5	170M2673	00	1000	20	2
FR6	NXI_0005	5.5	170M2673	00	1000	20	2
FR6	NXI_0007	7.5	170M2673	00	1000	20	2
FR6	NXI_0010	10	170M2673	00	1000	20	2
FR6	NXI_0013	13.5	170M2679	00	1000	63	2
FR6	NXI_0018	18	170M2679	00	1000	63	2
FR6	NXI_0022	22	170M2679	00	1000	63	2
FR6	NXI_0027	27	170M2679	00	1000	63	2
FR6	NXI_0034	34	170M2680	00	1000	160	2
FR7	NXI_0041	41	170M2683	00	1000	160	2
FR7	NXI_0052	52	170M2683	00	1000	160	2
FR8	NXI_0062	62	170M4199	1SHT	1250	400	2
FR8	NXI_0080	80	170M4199	1SHT	1250	400	2
FR8	NXI_0100	100	170M4199	1SHT	1250	400	2

Table 6-3. Fuses used in VACON® NX (640 - 1100V)

Information about fuses

aR fuses protect the cables of the device against short-circuits.

gR fuses are designed to protect the device against both overcurrent and short-circuits.

gG fuses are generally used to protect cables against overcurrent and short-circuits.

6.1.1.5 *Cable sizes, NXI xxxx 5*

Enclosure size	Type	I _L [A]	Supply cable Cu [mm ²]	Motor cable Cu [mm ²]	Terminal cable size	
					Main terminal [mm ²]	Earth terminal [mm ²]
FR4	NXI_0004 5—0009 5	3—9	2*1.5	3*1.5+1.5	1—4	1—2.5
	NXI_0012 5	12	2*2.5	3*2.5+2.5	1—4	1—2.5
FR6	NXI_0016 5—0045 5	16—45	2*10	3*10+10	2.5—50 Cu 6—50 Al	2.5—35
FR7	NXI_0061 5	61	2*16	3*16+16	2.5—50 Cu 6—50 Al	2.5—35
	NXI_0072 5	72	2*25	3*25+16	2.5—50 Cu 6—50 Al	6—70
	NXI_0087 5	87	2*35	3*35+16	2.5—50 Cu 6—50 Al	6—70
	NXI_0105 5	105	2*50	3*50+25	2.5—50 Cu 6—50 Al	6—70
FR8	NXI_0140 5	140	2*70	3*70+35	25—95 Cu/Al	25—95

Table 6-4. Cable sizes for VACON® NX_5

6.1.1.6 *Cable sizes, NXI xxxx 6*

Enclosure size	Type	I _L [A]	Supply cable Cu [mm ²]	Motor cable Cu [mm ²]	Terminal cable size	
					Main terminal [mm ²]	Earth terminal [mm ²]
FR6	NXI_0004 6—0007 6	3—7	2*2.5	3*2.5+2.5	2.5—50 Cu 6—50 Al	2.5—35
	NXI_0010 6—0013 6	10-13	2*2.5	3*2.5+2.5	2.5—50 Cu 6—50 Al	2.5—35
	NXI_0018 6	18	2*4	3*4+4	2.5—50 Cu 6—50 Al	2.5—35
	NXI_0022 6	22	2*6	3*6+6	2.5—50 Cu 6—50 Al	2.5—35
	NXI_0027 6—0034 6	27-34	2*10	3*10+10	2.5—50 Cu 6—50 Al	2.5—35
FR7	NXI_0041 6	41	2*100	3*10+10	2.5—50 Cu 6—50 Al	6—50
	NXI_0052 6	52	2*16	3*16+16	2.5—50 Cu 6—50 Al	6—50
FR8	NXI_0062—0080 6	62-80	2*25	3*25+16	25—95 Cu/Al	25—95
	NXI_0100 6	100	2*35	3*35+16		

Table 6-5. Cable sizes for VACON® NX_6

6.1.2 Installation instructions

1	Before starting the installation, check that none of the components of the inverter are live.						
2	If the inverter is installed outside the cubicle, cabinet or device space, you need to install a separate inverter cover (see, for example Figure 6-3) in accordance with protection class IP21 requirements. There is no need to install the inverter cover if the inverter is installed in a cubicle, separate cabinet or device space.						
3	<p>Place the motor cables sufficiently far from other cables:</p> <ul style="list-style-type: none"> ▪ Avoid placing the motor cables in long parallel lines with other cables ▪ If the motor cables runs in parallel with other cables, note the minimum distances between the motor cables and other cables given in the table below. ▪ The given distances also apply between the motor cables and signal cables of other systems. ▪ The maximum length of the motor cables is 300 m (units with power greater than 1.5 kW) and 100 m (units with power from 0.75 to 1.5 kW). ▪ The motor cables should cross other cables at an angle of 90 degrees. <table border="1" style="margin-left: auto; margin-right: auto;"> <thead> <tr> <th style="text-align: center;">Distance between cables [m]</th> <th style="text-align: center;">Shielded cable [m]</th> </tr> </thead> <tbody> <tr> <td style="text-align: center;">0.3</td> <td style="text-align: center;">≤50</td> </tr> <tr> <td style="text-align: center;">1.0</td> <td style="text-align: center;">≤200</td> </tr> </tbody> </table>	Distance between cables [m]	Shielded cable [m]	0.3	≤50	1.0	≤200
Distance between cables [m]	Shielded cable [m]						
0.3	≤50						
1.0	≤200						
4	If cable insulation checks are needed, see Chapter .						

	5	<p>Connect the cables:</p> <ul style="list-style-type: none">▪ Strip the motor and DC supply cables as advised in Figure 6-2 and Table 6-6.▪ Remove the screws of the cable protection plate. Do not open the cover of the power unit!▪ Make holes into and pass the cables through the rubber grommets on the bottom of the power unit. The rubber grommets are delivered in a separate bag.▪ Connect the DC supply, motor and control cables into their respective terminals.▪ For information on the installation of greater units, please contact the factory or your local distributor.▪ For Information on cable installation according to UL regulations, see Chapter 6.1.3.▪ For information on cable installation according to EMC regulations, see Chapter 6.1.3.▪ Make sure that the control cable wires do not come in contact with the electronic components of the unit.▪ If an external brake resistor (optional) is used, connect its cable to the appropriate terminal.▪ Check the connection of the earth cable to the motor and the inverter terminals marked with .▪ Connect the separate shield of the power cable to the earth terminals of the inverter, motor and the supply centre.▪ Attach the cable protection plate with the screws.▪ Ensure that the control cables or the cables of the unit are not trapped between the frame and the protection plate.
--	----------	---

6.1.2.1 *Stripping lengths of motor and DC supply cables*

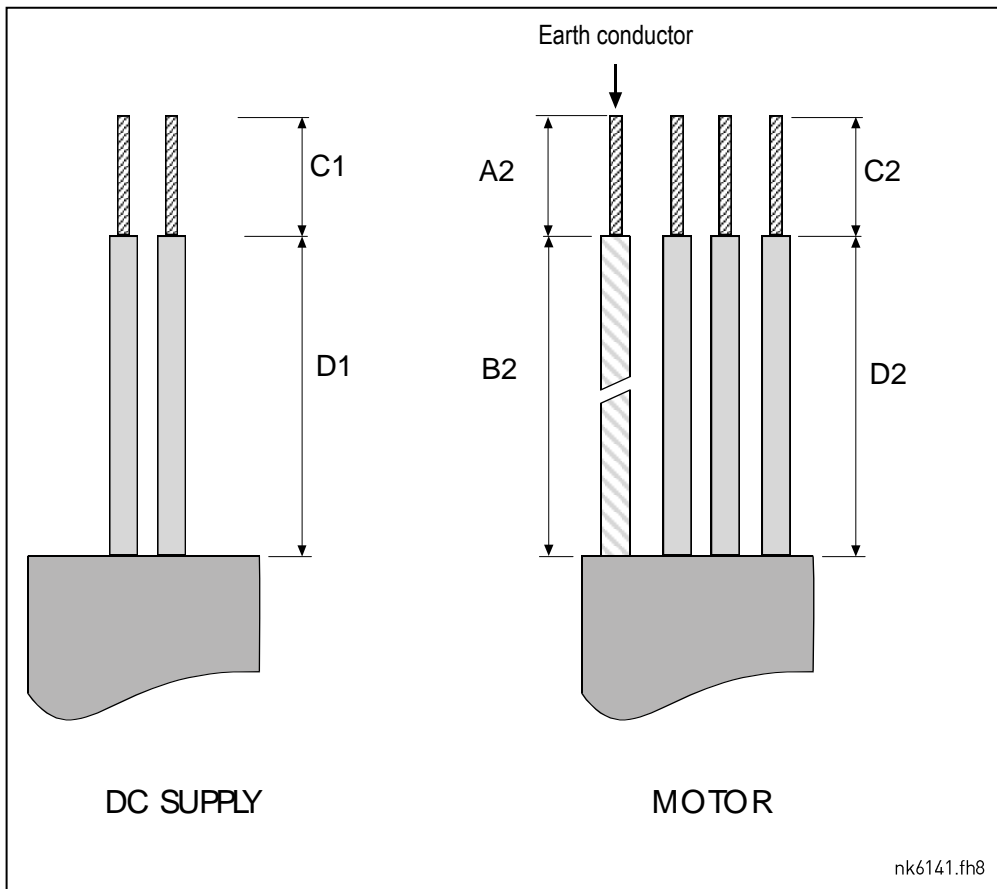

Figure 6-2. Stripping of cables

Enclosure size	C1	D1	A2	B2	C2	D2
FR4	10	20/70	7	50	7	35
FR6	15	60/80	20	90	15	60
FR7	25	120/140	25	120	25	120
FR8 0140	30	150	23	240	23	240

Table 6-6. Cable stripping lengths [mm]

6.1.2.2 VACON® NX enclosures

Figure 6-3. VACON® NXI, FR4



Figure 6-4. VACON® NXI, FR6, protection class IP21



Figure 6-5. VACON® NXI, FR7. Protection class IP21



Figure 6-6. VACON® NXI, FR8. Protection class IP00

6.1.3 Cable installation and the UL standards

To meet the UL (Underwriters Laboratories) regulations, a UL-approved copper cable with a minimum heat-resistance of +60/75°C must be used.

The integral solid state short circuit protection does not provide branch circuit protection. To supply the branch circuit protection, refer to the National Electric Code and the local regulations.

Use Class 1 wire only.

The tightening torques of the terminals are given below in Table 6-7.

Type	Enclosure size	Tightening torque [Nm]
NXI_0003 - 0012 5	FR4	0.5—0.6
NXI_0038 - 0061 5 NXI_0004 - 0034 6	FR6	10
NXI_0072 - 0105 5 NXI_0041 - 0080 6	FR7	10
NXI_0140 5 NXI_0062 - 0100 6	FR8	20/9*

Table 6-7. Tightening torques of terminals

* Tightening torque of terminal connection to the isolative base in Nm.

6.1.4 Cable and motor insulation checks

1. Motor cable insulation checks

Disconnect the motor cable from terminals U, V, and W of the inverter and from the motor.

Measure the insulation resistance of the motor cable between each phase conductor as well as between each phase conductor and the protective ground conductor.

The insulation resistance must be $>1\text{M}\Omega$.

2. DC supply cable insulation checks

Disconnect the DC supply cable from terminals B- and B+ of the inverter and from DC supply.

Measure the insulation resistance between each conductor and ground.

The insulation resistance must be $>1\text{M}\Omega$.

3. Motor insulation checks

Disconnect the motor cable from the motor and open the bridging connections in the motor connection box. Measure the insulation resistance of each motor winding. The measurement voltage must equal at least the motor nominal voltage but not exceed 1,000 V.

The insulation resistance must be $>1\text{M}\Omega$.

6.2 Control unit

The control unit of the inverter consists of the control board and option boards (see Figure 6-7 and Figure 6-20) connected to the five slot connectors (A to E) on the control board. The control board is connected to the power unit through a D connector (1).

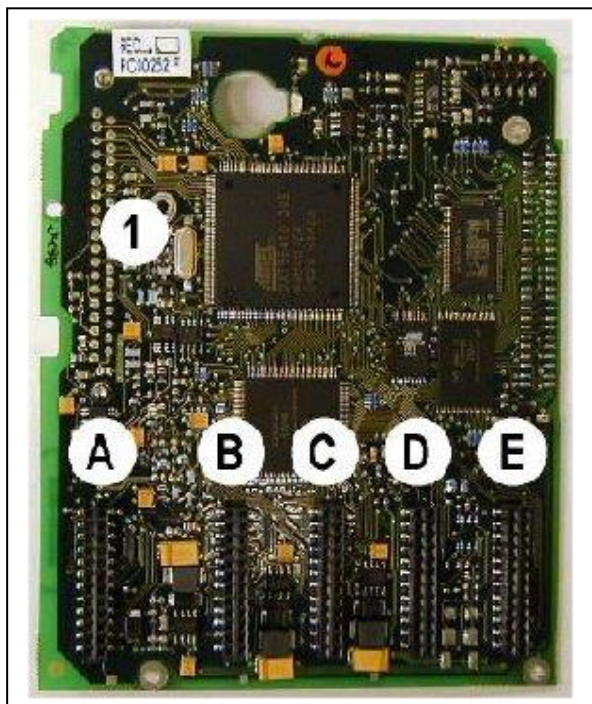

Figure 6-7. control board

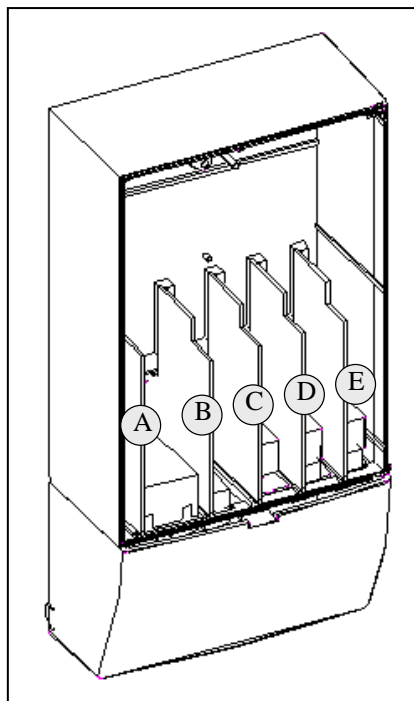

Figure 6-8. Basic and option board connections on the control board

When the inverter is delivered from the factory, the control unit usually includes two basic boards (I/O board and relay board), which are normally installed in slots A and B. On the next pages you will find the arrangement of the control I/O and the relay terminals of the two basic boards, the general wiring diagram and the control signal descriptions. The I/O boards mounted at the factory are indicated in the type code. For more information on the option boards, see VACON® NX option board manual.

6.2.1 Control voltage (+24V/EXT +24V)

It is possible to use the drive with an external power source with these properties: +24 VDC $\pm 10\%$, minimum 1000 mA. You can use it to externally power-up the control board, and the basic and expander boards.

Connect the external power source to one of the 2 bidirectional terminals (#6 or #12), see Figure 48. With this voltage, the control unit stays on and you can set the parameters. The measurements of the main circuit (for example, the DC link voltage, and the unit temperature) are not available when the drive is not connected to mains.

NOTE! If you supply the AC drive with external 24 V DC power, you must use a diode in terminal #6 (or #12) to prevent the current to flow in opposite direction. Put a 1 A fuse in 24 V DC line for each AC drive. The maximum current consumption of each drive is 1 A from the external power supply.

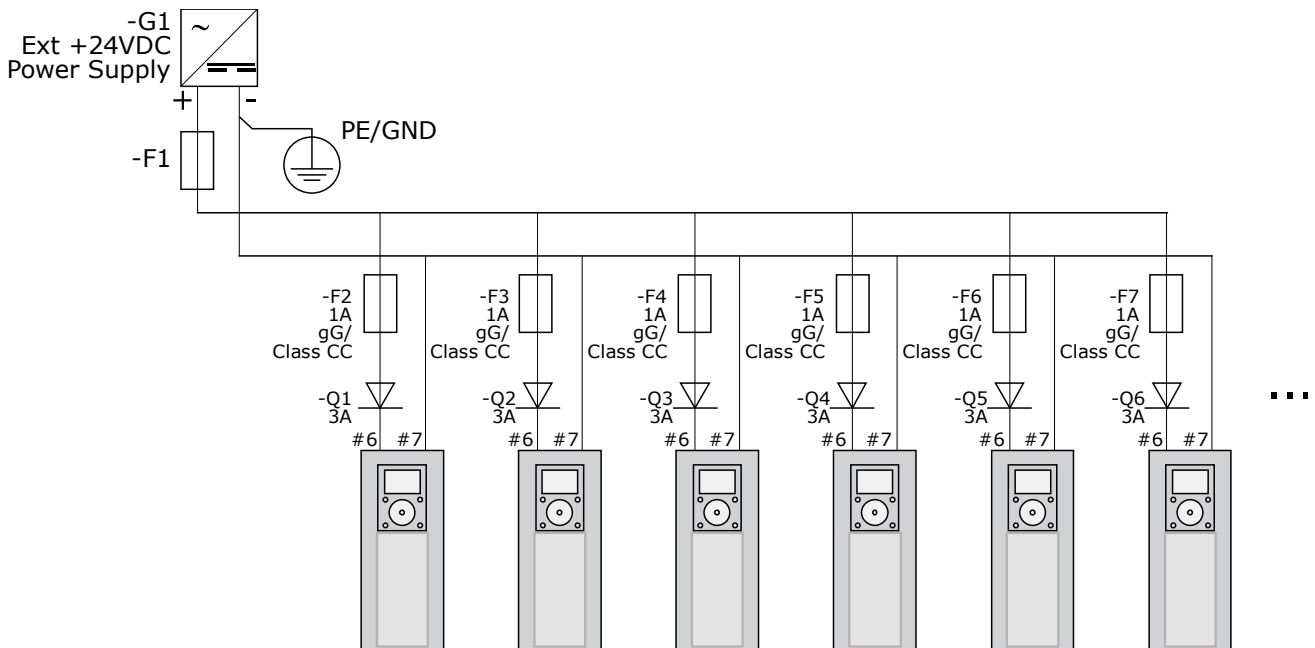

Figure 6-9. Parallel connection of 24 V inputs with many AC drives

NOTE! The control unit I/O ground is not isolated from the chassis ground / protective earth. In the installation, take into account the potential differences between the grounding points. We recommend that you use galvanic isolation in the I/O and 24V circuitry.

NOTE! Analogue outputs and inputs do not work with only +24V supplied to the control unit.

If there is a +24V/EXT+24V output on the board, it is locally short-circuit protected. If one of the +24V/EXT+24V outputs short-circuits, the others remain powered because of the local protection.

6.2.2 Control connections

The basic control connections for boards A1 and A2/A3 are shown in Chapter 6.2.3.

The signal descriptions for the standard application are presented in Chapter 2 of the All in One Application Manual. You can find the signal descriptions for **other applications** in the VACON® NX Application Manual.

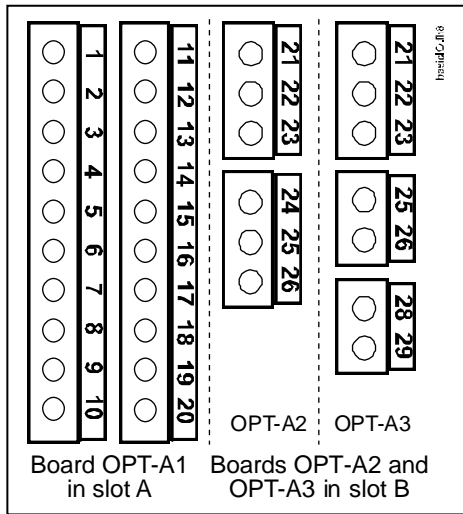

Figure 6-10. The I/O terminals of the two basic boards

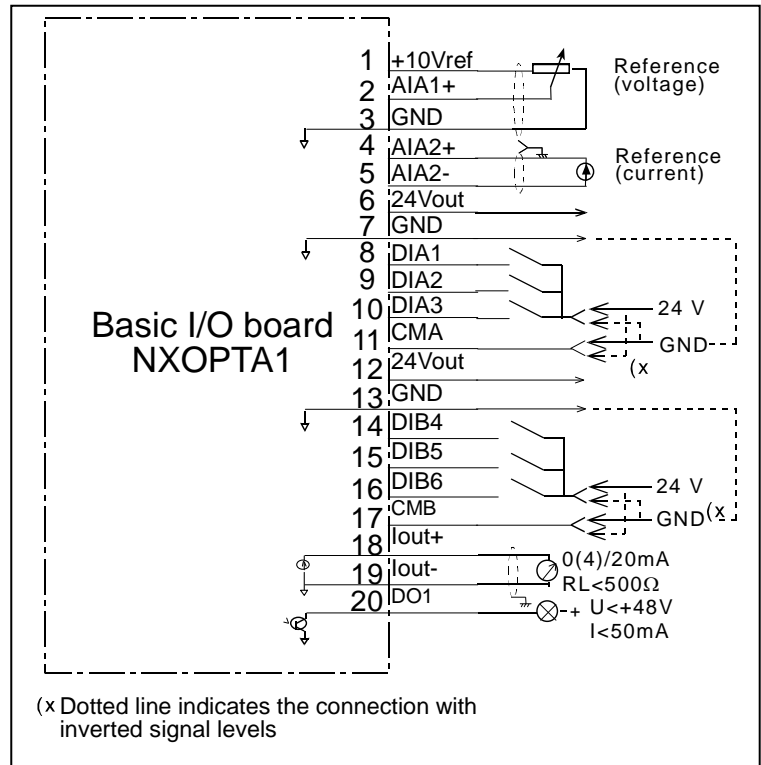

Figure 6-11. General wiring diagram of the basic I/O board (NXOPTA1)

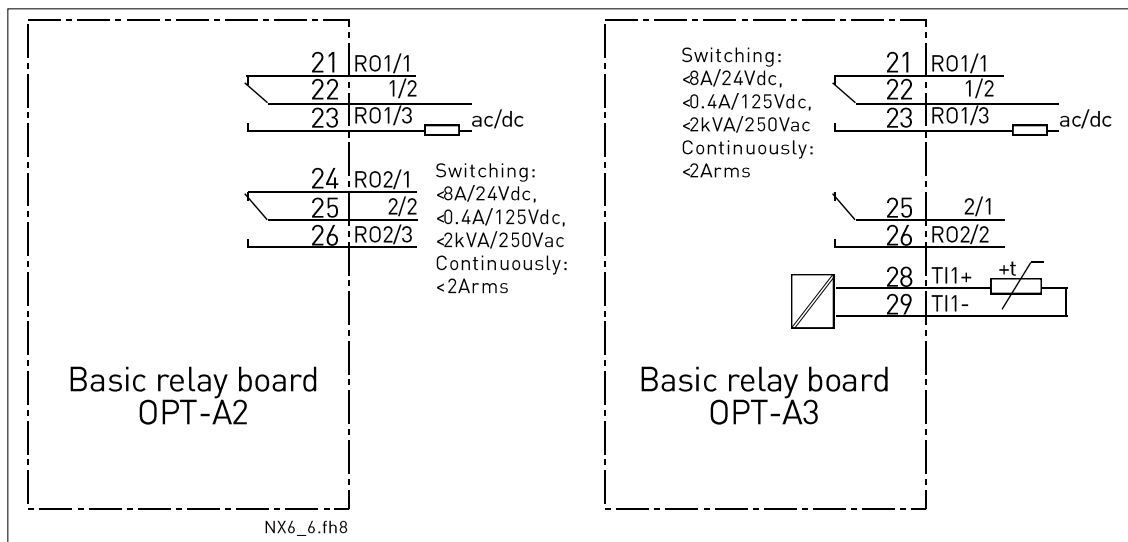

Figure 6-12. General wiring diagram of the basic relay boards (NXOPTA2/NXOPTA3)

6.2.2.1 Control cables

The control cables shall be at least 0.5 mm² screened multicore cables, see Table 6–8. The maximum terminal wire size is 2.5 mm² for the relay terminals and 1.5 mm² for other terminals.

You can find the tightening torques of the option board terminals below.

Terminal screw	Tightening torque	
	Nm	lb-in.
Relay and thermistor terminals (screw M3)	0.5	4.5
Other terminals (screw M2.6)	0.2	1.8

Table 6–8. Tightening torques of terminals

6.2.2.2 Galvanic isolation barriers

The control connections are isolated from the mains potential and the GND terminals are permanently connected to ground. See below.

The digital inputs are galvanically isolated from the I/O ground. The relay outputs are additionally double-isolated from each other at 300VAC (EN-50178).

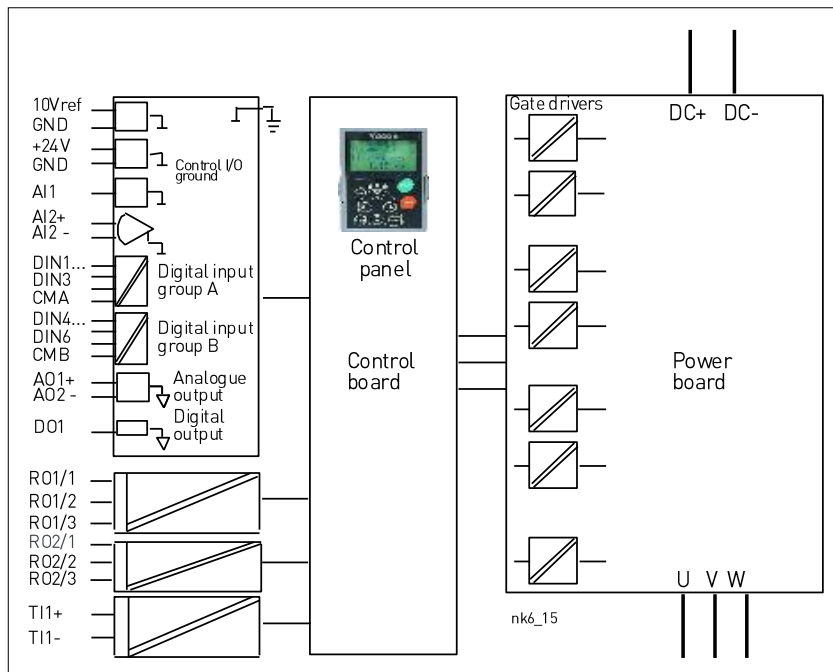

Figure 6-13. Galvanic isolation barriers

6.2.3 Control terminal signals

Terminal	Signal	Technical information
1	+10 Vref	Reference voltage Maximum current 10 mA
2	AI1+	Analogue input, voltage or current Selection V or mA with jumper block X1 (see page 50): Default: 0– +10V (R _i = 200 kΩ) (-10V.....+10V Joy-stick control, selected with a jumper) 0– 20mA (R _i = 250 Ω)
3	GND/AI1–	Analogue input common Differential input if not connected to ground; Allows ±20V differential mode voltage to GND
4	AI2+	Analogue input, voltage or current Selection V or mA with jumper block X1 (see page 50): Default: 0– 20mA (R _i = 250 Ω) 0– +10V (R _i = 200 kΩ) (-10V.....+10V Joy-stick control, selected with a jumper)
5	GND/AI2–	Analogue input common Differential input if not connected to ground; Allows ±20V differential mode voltage to GND
6	24 Vout (bidirectional)	24V auxiliary voltage ±15%; maximum current 250 mA all boards total; 150 mA from single board. Can also be used as external power backup for the control unit (and fieldbus).
7	GND	I/O ground Ground for reference and controls
8	DIN1	Digital input 1
9	DIN2	Digital input 2
10	DIN3	Digital input 3
11	CMA	Digital input common A for DIN1, DIN2 and DIN3. Must be connected to GND or 24V of I/O terminal or to external 24V or GND Selection with jumper block X3 (see page 50):
12	24 Vout (bidirectional)	24V auxiliary voltage Same as terminal #6
13	GND	I/O ground Same as terminal #7
14	DIN4	Digital input 4
15	DIN5	Digital input 5
16	DIN6	Digital input 6
17	CMB	Digital input common B for DIN4, DIN5 and DIN6 Must be connected to GND or 24V of I/O terminal or to external 24V or GND Selection with jumper block X3 (see page 50):
18	AO1+	Analogue signal (+output)
19	AO1–	Analogue output common Output signal range: Current 0(4)–20mA, R _L max. 500Ω or Voltage 0–10V, R _L >1kΩ Selection with jumper block X3 (see page 50):
20	DO1	Open collector output Maximum U _{in} = 48VDC Maximum current = 50 mA

Table 6–9. Control I/O terminal signals on basic I/O board NXOPTA1

NXOPTA2					
21	R01/1		Relay output 1	Switching capacity	24VDC/8A
22	R01/2				250VAC/8A
23	R01/3				125VDC/0.4A
24	R02/1		Relay output 2	Switching capacity	24VDC/8A
25	R02/2				250VAC/8A
26	R02/3				125VDC/0.4A
				Min.switching load	5V/10mA

Table 6-10. Control I/O terminal signals on basic relay board NXOPTA2

NXOPTA3					
21	R01/1		Relay output 1	Switching capacity	24VDC/8A
22	R01/2				250VAC/8A
23	R01/3				125VDC/0.4A
25	R02/1		Relay output 2	Switching capacity	24VDC/8A
26	R02/2				250VAC/8A
					125VDC/0.4A
				Min.switching load	5V/10mA
28	TI1+		Thermistor input		
29	TI1-				

Table 6-11. Control I/O terminal signals on basic relay board NXOPTA3

6.2.3.1 Digital input signal inversions

The active signal level depends on which potential the common inputs CMA and CMB (terminals 11 and 17) are connected to. The alternatives are either +24V or ground (0 V). See Figure 6-14. We recommend the use of positive logic in all control connections of the inverter. If negative logic is used, additional appropriate measures are needed to meet the safety regulation requirements.

The 24 volt control voltage and the ground for the digital inputs and the common inputs (CMA, CMB) can be either internal or external.

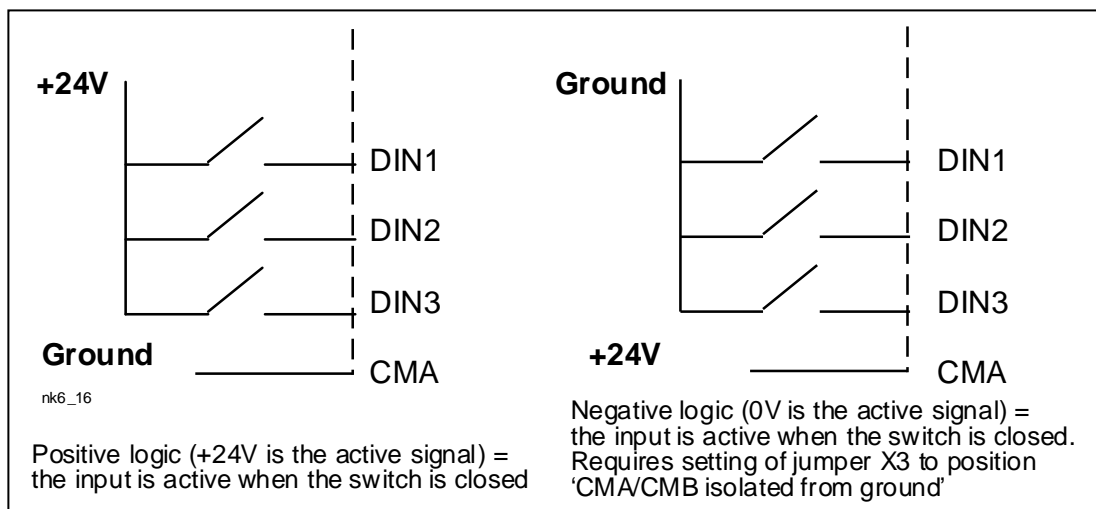

Figure 6-14. Positive/Negative logic

6.2.3.2 Jumper selections on the NXOPTA1 basic board

The user can customise the functions of the inverter to better suit his needs by selecting certain positions for the jumpers on the NXOPTA1 board. The positions of the jumpers determine the signal type of analogue and digital inputs.

On the A1 basic board, there are four jumper blocks (X1, X2, X3 and X6) each containing eight pins and two jumpers. The selection possibilities of the jumpers are shown on page 50 (Figure 6-16).

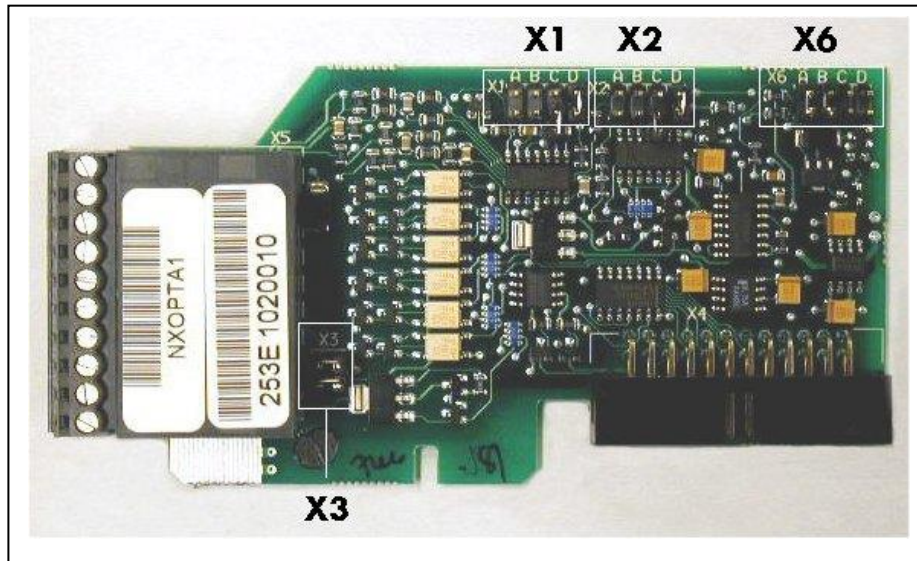

Figure 6-15. Jumper blocks on NXOPTA1

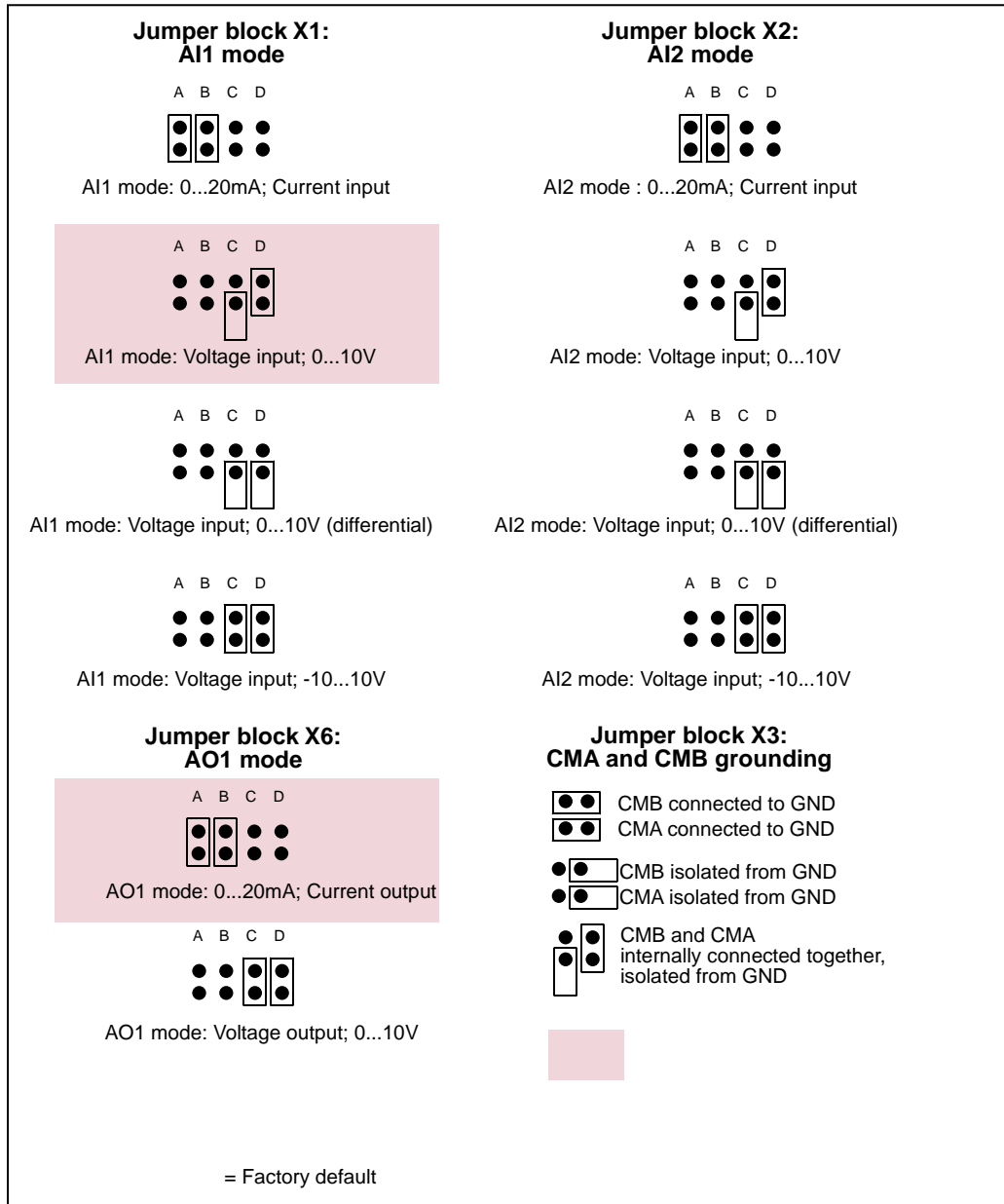

Figure 6-16. Jumper selection for NXOPTA1

 WARNING	<p>Ensure that the jumper positions are correct. Running the motor with signal settings that differ from the jumper positions will not harm the inverter but may harm the motor.</p>
NOTE!	<p>If you change the AI/AO signal content also remember to change the corresponding board parameter in menu M7.</p>

7. CONTROL KEYPAD

The control keypad is the link between the VACON® inverter and the user. The VACON® NX control keypad features an alphanumeric display with seven indicators for the Run status (RUN, ↻, ↻, READY, STOP, ALARM, FAULT) and three indicators for the control place (I/O term/Keypad/BusComm). There are also three Status Indicator LEDs (green – green – red), see section 7.1.3.

The control information, i.e. the menu number, description of the menu or the displayed value and the numeric information are presented on three text lines.

The inverter is operable through the nine push-buttons of the control keypad. Furthermore, the buttons can be used in setting parameters and monitoring values.

The keypad is detachable and isolated from the input line potential.

7.1 Indicators on the keypad display

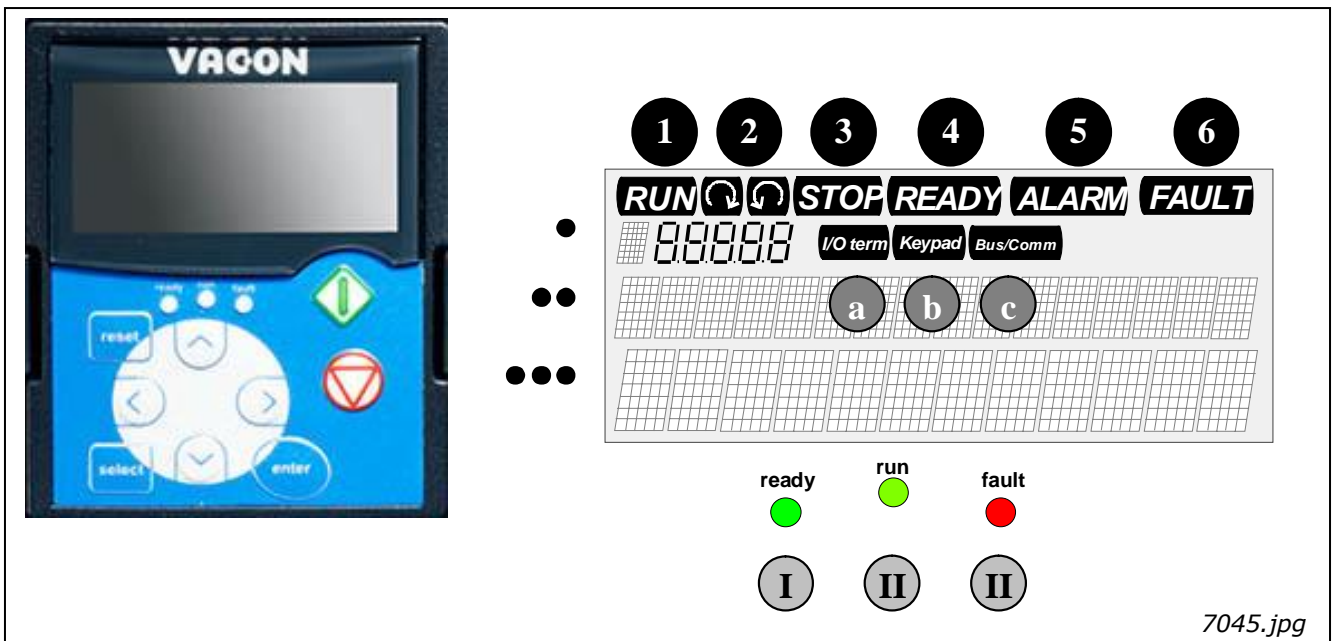

Figure 7-1. VACON® control keypad and drive status indications

7.1.1 Drive status indications

The drive status symbols tell the user the status of the motor and the inverter. In addition, they tell about possible irregularities detected by the motor control software in motor or inverter functions.

- 1 RUN = Motor is running; Blinks when the stop command has been given but the frequency is still ramping down.
- 2 ↻ ↻ = Indicates the direction of motor rotation.
- 3 STOP = Indicates that the drive is not running.

- 4 READY = Lights up when AC power is on. In case of a trip, the symbol will not light up.
- 5 ALARM = Indicates that the drive is running outside a certain limit and a warning is given.
- 6 FAULT = Indicates that unsafe operating conditions were encountered due to which the drive was stopped.

7.1.2 Control place indicators

The symbols *I/O term*, *Keypad* and *Bus/Comm* (see Figure 7-1) indicate the choice of control place made in the Keypad control menu (M3) (see Chapter 7.3.3).

- a *I/O term* = I/O terminals are selected as the control place i.e. START/STOP commands or reference values etc. are given through the I/O terminals.
- b *Keypad* = Control keypad is selected as the control place i.e. the motor can be started or stopped, or its reference values etc. altered from the keypad.
- c *Bus/Comm* = The inverter is controlled through a fieldbus.

7.1.3 Status LEDs (green – green – red)

The status LEDs light up in connection with the READY, RUN and FAULT drive status indicators.

- I ● = lights up with the AC power connected to the drive. Simultaneously, the drive status indicator READY is lit up.
- II ● = Lights up when the drive is running. Blinks when the STOP button has been pushed and the drive is ramping down.
- III ● = Lights up when unsafe operating conditions were encountered due to which the drive was stopped (Fault Trip). Simultaneously, the drive status indicator FAULT blinks on the display and the fault description can be seen, see Chapter 7.3.3.4, Active faults.

7.1.4 Text lines

The three text lines (●, ●●, ●●●) provide the users with information on their present location in the keypad menu structure as well as with information related to the operation of the drive.

- = Location indicator; displays the symbol and number of the menu, parameter, etc.
Example: **M2** = Menu 2 (Parameters); **P2.1.3** = Acceleration time
- = Description line; Displays the description of the menu, value or fault.
- = Value line; Displays the numerical and textual values of references, parameters, etc. and the number of submenus available in each menu.

7.2 Keypad push-buttons

The VACON® alphanumeric control keypad has 9 push-buttons that are used for controlling the inverter (and motor), setting parameters, and monitoring values.

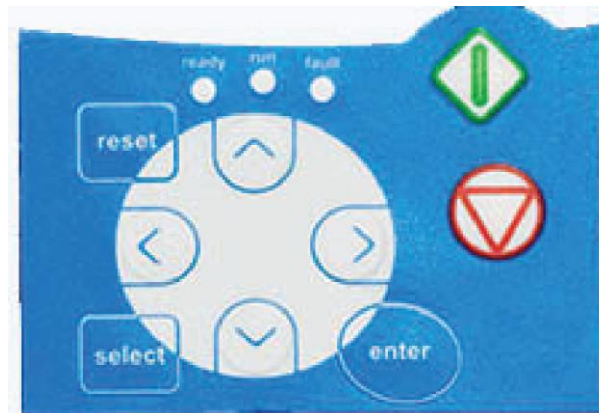











Figure 7-2 Keypad push-buttons

7.2.1 Button descriptions

-  = This button is used to reset active faults (see Chapter 7.3.3.4).
-  = This button is used to switch between the two latest displays. This may be useful when you want to see how the changed new value influences some other value.
-  = The enter button is used for:
 - 1) confirmation of selections
 - 2) fault history reset (2...3 seconds)
-  = Browser button up
Browse the main menu and the pages of different submenus.
Edit values.
-  = Browser button down
Browse the main menu and the pages of different submenus.
Edit values.
-  = Menu button left
Move backward in menu.
Move cursor left (in parameter menu).
Exit edit mode.
Press for 2 to 3 seconds to return to main menu.

-  = Menu button right
 Move forward in menu.
 Move cursor right (in parameter menu).
 Enter edit mode.
-  = Start button
 Pressing this button starts the motor if the keypad is the active control place. See Chapter 7.3.3.
-  = Stop button
 Pressing this button stops the motor (unless disabled by parameter R3.4/R3.6). See Chapter 7.3.3.

7.3 Navigation on the control keypad

The data on the control keypad is arranged in menus and submenus. The menus are used for the display and editing of measurement and control signals, parameter settings (see Chapter 7.3.2) and reference value and fault displays (see Chapter 7.3.3.4). Through the menus, you can also adjust the contrast of the display (see Chapter 7.3.6.6).

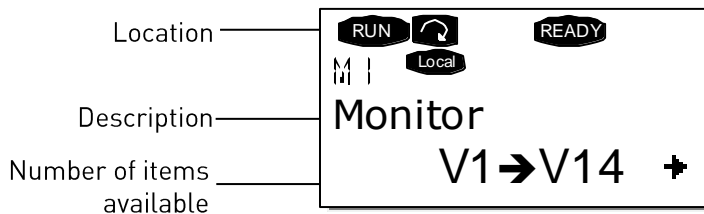

The first menu level consists of menus M1 to M7 and is called the *Main menu*. The user can navigate in the main menu with the *Browser buttons* up and down. The desired submenu can be entered from the main menu with the *Menu buttons*. When there still are pages to enter under the currently displayed menu or page, you can see an arrow (➔) in the lower right corner of the display and can reach the next menu level by pressing *Menu button right*.

The control keypad navigation chart is shown on the next page. Please note that menu **M1** is located in the lower left corner. From there you will be able to navigate your way up to the desired menu using the menu and browser buttons.

You will find more detailed descriptions of the menus later in this chapter.

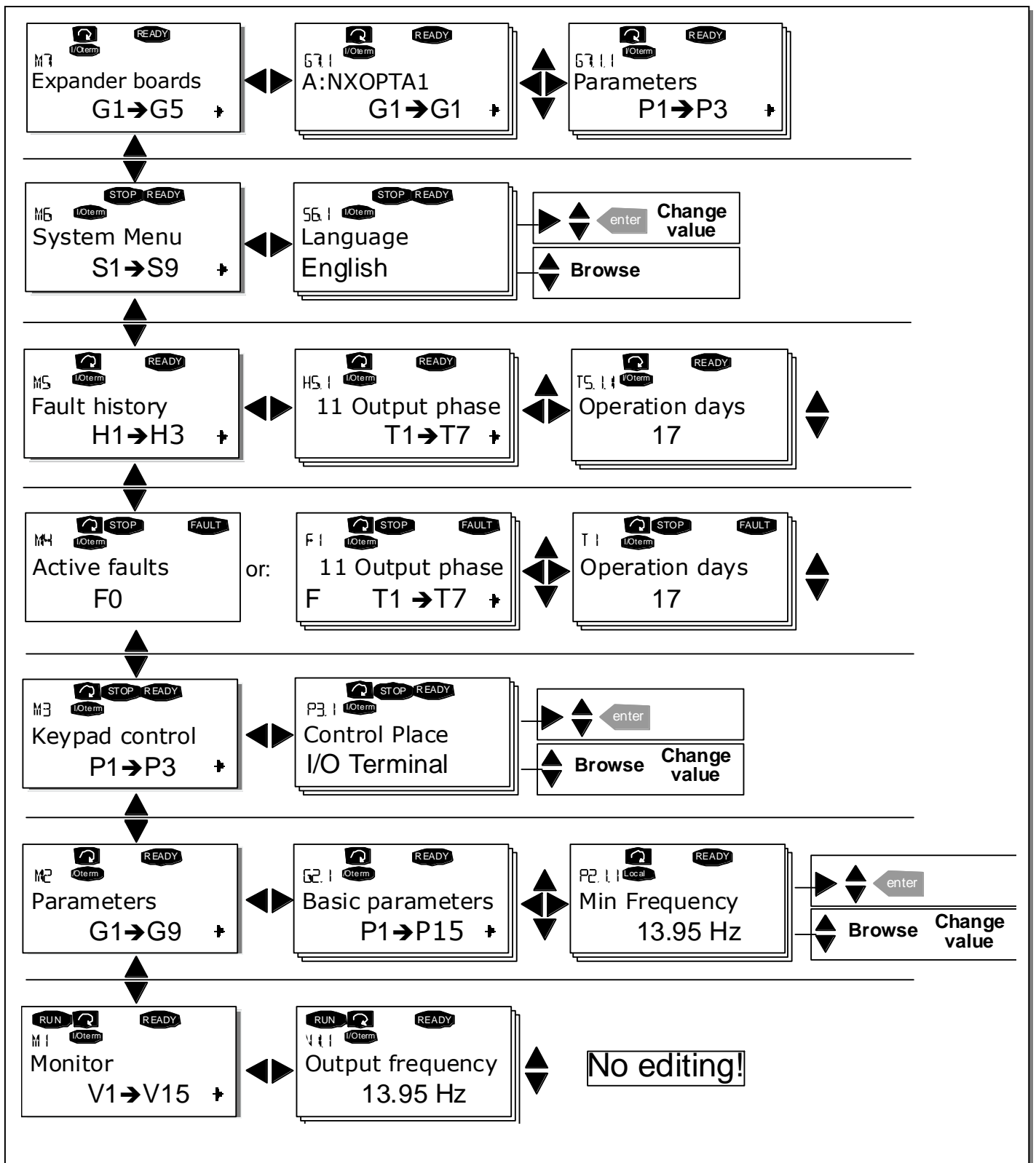

Figure 7-3 Keypad navigation chart

7.3.1 Monitoring menu (M1)

You can enter the Monitoring menu from the Main menu by pressing *Menu button right* when the location indication **M1** is visible on the first line of the display. Figure 3-1 shows how to browse through the monitored values.

The monitored signals carry the indication **V#. #** and they are listed in Table 7-1. The values are updated once every 0.3 seconds.

This menu is meant only for signal checking. The values cannot be altered here. For changing values of parameters, see Chapter 7.3.2.

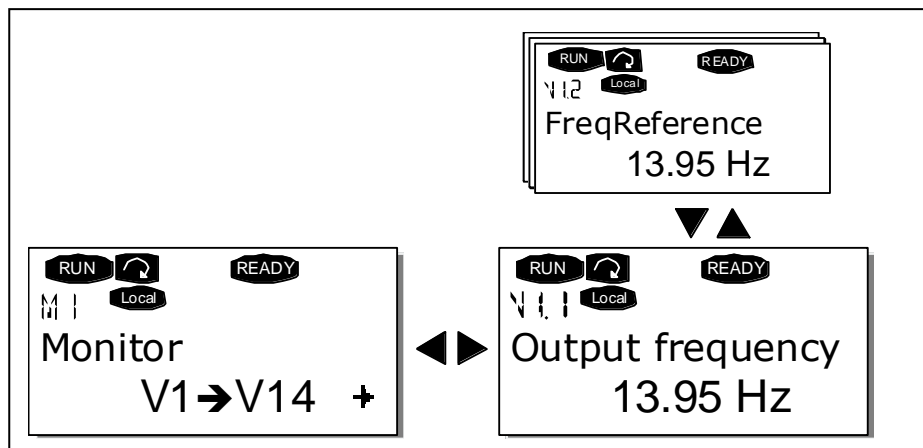

Figure 7-4 Monitoring menu

Code	Signal name	Unit	Description
V1.1	Output frequency	Hz	Frequency to the motor
V1.2	Frequency reference	Hz	
V1.3	Motor speed	rpm	Calculated motor speed
V1.4	Motor current	A	Measured motor current
V1.5	Motor torque	%	Calculated actual torque/nominal torque of the unit
V1.6	Motor power	%	Calculated actual power/nominal power of the unit
V1.7	Motor voltage	V	Calculated motor voltage
V1.8	DC-link voltage	V	Measured DC-link voltage
V1.9	Unit temperature	°C	Heat sink temperature
V1.10	Motor temperature	%	Calculated motor temperature
V1.11	Voltage input	V	AI1
V1.12	Current input	mA	AI2
V1.13	DIN1, DIN2, DIN3		Digital input statuses
V1.14	DIN4, DIN5, DIN6		Digital input statuses
V1.15	DO1, RO1, RO2		Digital and relay output statuses
V1.16	Analogue output	mA	AO1
M1.17	Multimonitoring items		Displays three selectable monitoring values. See chapter 7.3.6.5.

Table 7-1. Monitored signals

Note! All in One applications may embody more monitoring values.

7.3.2 Parameter menu (M2)

Parameters are the way of conveying the commands of the user to the inverter. Parameter values can be edited by entering the *Parameter Menu* from the *Main Menu* when the location indication **M2** is visible on the first line of the display. The value editing procedure is presented in Figure 7-1.

Pressing *Menu button right* once takes you to the Parameter Group Menu (*G#*). Locate the desired parameter group by using the *Browser buttons* and press *Menu button right* again to see the group and its parameters. Use the *Browser buttons* to find the parameter (*P#*) you want to edit. Pressing *Menu button right* takes you to the edit mode. As a sign of this, the parameter value starts to blink. You can now change the value in two different ways:

- Set the desired value with the *Browser buttons* and confirm the change with the *enter* button. Consequently, the blinking stops and the new value is visible in the value field.
- Press *Menu button right* once more. Now you will be able to edit the value digit by digit. This may come in handy, when a relatively greater or smaller value than that on the display is desired. Confirm the change with the *enter* button.

The value will not change unless the Enter button is pressed. Pressing *Menu button left* takes you back to the previous menu.

Several parameters are locked, i.e. cannot be edited, when the drive is in RUN status. If you try to change the value of such a parameter the text **Locked** will appear on the display. The inverter must be stopped to edit these parameters.

The parameter values can also be locked using the function in menu **M6** (see Chapter 6.5.2)).

You can return to the Main menu any time by pressing *Menu button left* for 1 to 2 seconds.

The basic application package "All in One+" includes seven applications with different sets of parameters. You will find the parameter lists in the Application Section of this manual.

Once in the last parameter of a parameter group, you can move directly to the first parameter of that group by pressing *Browser button up*.

See the diagram for parameter value change procedure on page 59.

Note: You can connect power to the control board by connecting the external power source to the bidirectional terminal #6 on the NXOPTA1 board (see page 47). The external power source can also be connected to the corresponding +24V terminal on any option board. This voltage is sufficient for parameter setting and for keeping the fieldbus active.

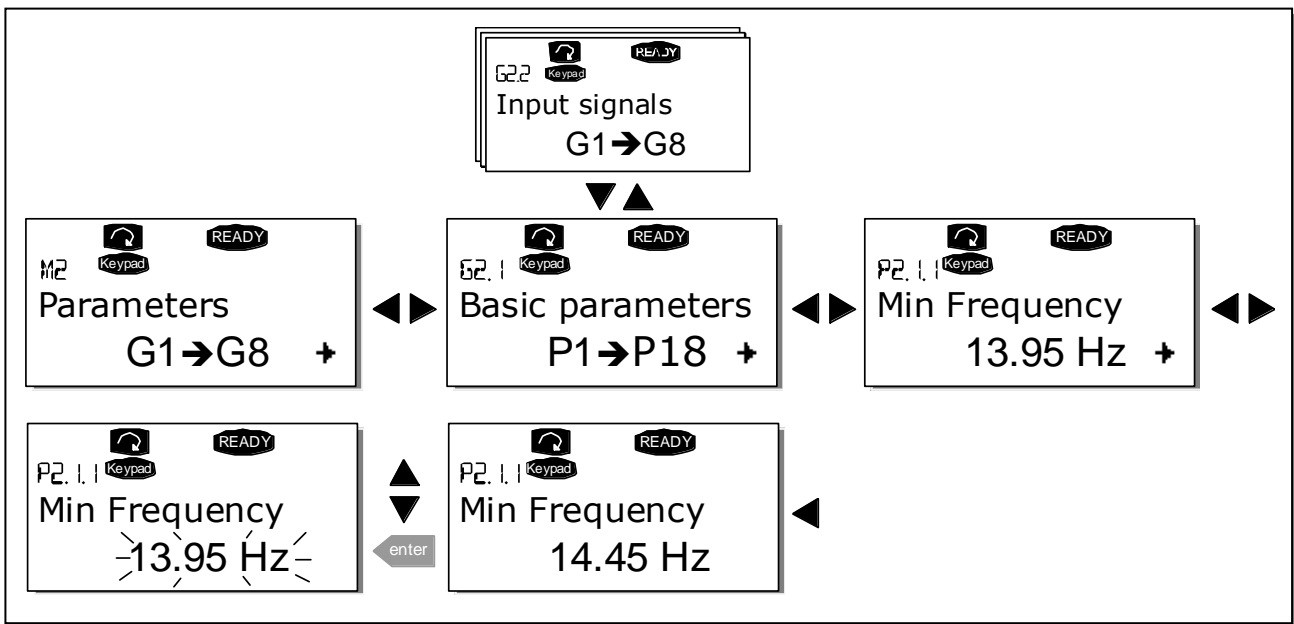

Figure 7-5. Parameter value change procedure

7.3.3 Keypad control menu (M3)

In the *Keypad Control Menu*, you can choose the control place, edit the frequency reference and change the direction of the motor. You can enter the submenu level by pressing *Menu button right*.

7.3.3.1 Selection of control place

There are three different places (sources) where the inverter can be controlled from. For each control place, a different symbol will appear on the alphanumeric display:

Control place	Symbol
I/O terminals	I/O term
Keypad (panel)	Keypad
Fieldbus	Bus/Comm

You can change the control place by entering the edit mode with *Menu button right*. The options can then be browsed with the *Browser buttons*. Select the desired control place with the *enter* button. See the diagram on the next page. See also Chapter 7.3.3. above.

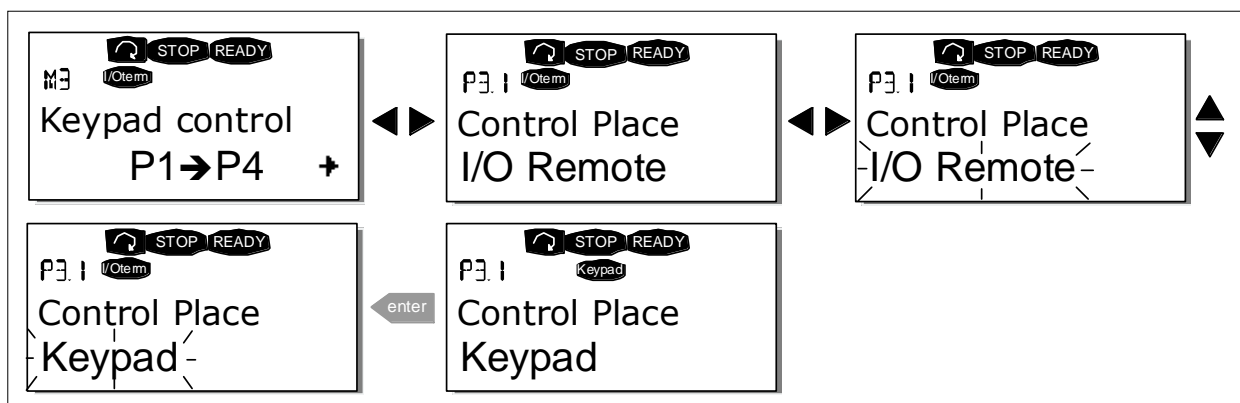

Figure 7-6. Selection of control place

7.3.3.2 Keypad reference

The keypad reference submenu (P3.2) displays and allows the operator to edit the frequency reference. The changes will take place immediately. **This reference value will not, however, influence the rotation speed of the motor unless the keypad has been selected as the active control place.**

NOTE: The maximum difference in RUN mode between the output frequency and the keypad reference is 6 Hz. The program automatically monitors the keypad reference value. See also Chapter 7.3.3.

Figure 7-1 shows how to edit the reference value (pressing the *enter* button is not necessary).

7.3.3.3 Keypad direction

The keypad direction submenu (P3.3) displays and allows the operator to change the rotating direction of the motor. **This setting will not, however, influence the rotation direction of the motor unless the keypad has been selected as the active control place.**

See also Chapter 7.3.3.

Note: For additional information on controlling the motor with the keypad, see Chapters 7.2.1, 7.3.3 and 8.2.

7.3.3.4 Stop button activated

By default, pushing the STOP button will **always** stop the motor regardless of the selected control place. You can disable this function by giving parameter 3.4 the value **0**. If the value of this parameter is **0**, the STOP button will stop the motor only **when the keypad has been selected as the active control place**.

NOTE! *There are some special functions that can be performed in menu M3:*
Select the keypad as the active control place by pressing START for 3 seconds **when the motor is running**. The keypad will become the active control place and the current frequency reference and direction will be copied to the keypad.
Select the keypad as the active control place by pressing STOP for 3 seconds **when the motor is stopped**. The keypad will become the active control place and the current frequency reference and direction will be copied to the keypad.

Copy the frequency reference set elsewhere (I/O, fieldbus) to the panel by pressing

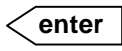
 for 3 seconds.

Note that if you are in any other than menu **M3** these functions will not work.
If you are in some other than menu **M3** and try to start the motor by pressing the START button when the keypad is not selected as the active control place, you will get an error message: *Keypad Control NOT ACTIVE*.

7.3.4 Active faults menu (M4)

You can enter the Active faults menu from the Main menu by pressing *Menu button right* when the location indication **M4** is visible on the first line of the keypad display.

When a fault brings the inverter to a stop, the location indication **F1**, the fault code, a short description of the fault, and the **fault type symbol** (see Chapter 7.3.4.1) will appear on the display. In addition, the indication **FAULT** or **ALARM** (see Figure 7-1 or Chapter 7.1.1) is displayed and, in case of a **FAULT**, the red LED on the keypad starts to blink. If several faults occur simultaneously, the list of active faults can be browsed with the *Browser buttons*.

The memory of active faults can store a maximum of 10 faults in the order of appearance. The display can be cleared with the *reset* button and the read-out will return to the same state it was in before the fault trip. The fault remains active until it is cleared with the *reset button* or with a reset signal from the I/O terminal.

Note! Remove external Start signal before resetting the fault to prevent unintentional restart of the drive.



7.3.4.1 Fault types

The NX inverter has four types of faults. These types differ from each other on the basis of the subsequent behaviour of the drive. See Table 7-3.

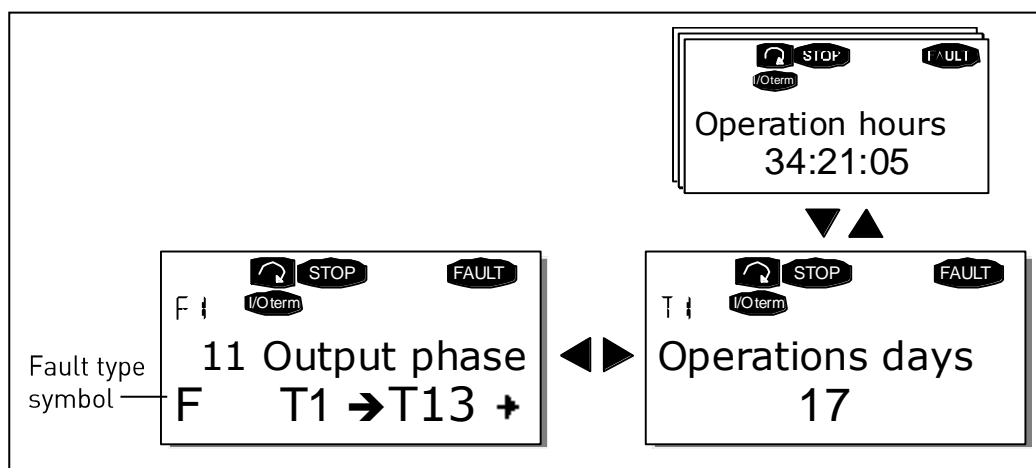

Figure 7-7. Fault display

Fault type symbol	Meaning
A (Alarm)	This type of fault is a sign of an unusual operating condition. It does not cause the drive to stop, nor does it require any special actions. The 'A fault' remains in the display for about 30 seconds.
F (Fault)	An 'F fault' makes the drive stop. Actions need to be taken to restart the drive.
AR (Fault Autoreset)	If an 'AR fault' occurs the drive will stop immediately. The fault is reset automatically and the drive tries to restart the motor. Finally, if the restart is not successful, a fault trip (FT, see below) occurs.
FT (Fault Trip)	If the drive is unable to restart the motor after an AR fault an FT fault occurs. The 'FT fault' has basically the same effect as the F fault: the drive is stopped.

Table 7-2. Fault types

7.3.4.2 *Fault codes*

The fault codes, their causes and correcting actions are presented in the table below. The shadowed faults are A faults only. The items in white on black background are faults for which you can program different responses in the application. See parameter group Protections.

Note! When contacting the distributor or factory because of a fault condition, always write down all texts and codes visible on the keypad display.

Fault code	Fault	Possible cause	Correcting measures
1	Overcurrent	Inverter has detected too high a current ($>4 \cdot I_n$) in the motor cable: sudden heavy load increase short circuit in motor cables unsuitable motor	Check loading. Check motor. Check cables.
2	Overvoltage	The DC-link voltage has exceeded the limits defined in Table 4-3 too short a deceleration time high overvoltage spikes in supply	Set the deceleration time longer. Add a brake chopper or a brake resistor.
3	Earth fault	Current measurement has detected that the sum of motor phase current is not zero. insulation failure in cables or motor	Check motor cable and motor.
5	Charging switch	The charging switch is open, when the START command has been given. faulty operation component failure	Reset the fault and restart. Should the fault re-occur, contact the distributor near to you. For local contacts, go to: http://drives.danfoss.com/danfoss-drives/local-contacts/
6	Emergency stop	Stop signal has been given from the option board.	
7	Saturation trip	Various causes: component failure brake resistor short-circuit or overload	Cannot be reset from the keypad. Switch off power. DO NOT RE-CONNECT POWER! Contact factory. If this fault appears simultaneously with Fault 1, check motor cables and motor
8	System fault	component failure faulty operation Note the exceptional Fault data record. See 7.3.4.3.	Reset the fault and restart. Should the fault re-occur, contact the distributor near to you. For local contacts, go to: http://drives.danfoss.com/danfoss-drives/local-contacts/
9	Undervoltage	DC-link voltage is under the voltage limits defined in Table 4-3. most probable cause: too low a supply voltage inverter internal fault	In case of temporary supply voltage break, reset the fault and restart the inverter. Check the supply voltage. If it is adequate, an internal failure has occurred. Contact the distributor near to you. For local contacts, go to: http://drives.danfoss.com/danfoss-drives/local-contacts/
11	Output phase supervision	Current measurement has detected that there is no current in one motor phase.	Check motor cable and motor.

Fault code	Fault	Possible cause	Correcting measures
12	Brake chopper supervision	No brake resistor installed brake resistor is broken brake chopper failure	Check brake resistor. If the resistor is ok, the chopper is faulty. Contact the distributor near to you.
13	Inverter undertemperature	Heatsink temperature is under -10°C	
14	Inverter overtemperature	Heatsink temperature is over 90°C or 77°C (NX_6, FR6). Overtemperature warning is issued when the heatsink temperature exceeds 85°C (72°C).	Check the correct amount and flow of cooling air. Check the heatsink for dust. Check the ambient temperature. Make sure that the switching frequency is not too high in relation to ambient temperature and motor load.
15	Motor stalled	Motor stall protection has tripped.	Check motor.
16	Motor over-temperature	Motor overheating has been detected by inverter motor temperature model. Motor is overloaded.	Decrease the motor load. If no motor overload exists, check the temperature model parameters.
17	Motor underload	Motor underload protection has tripped.	
22	EEPROM checksum fault	Parameter save fault faulty operation component failure	
24	Counter fault	Values displayed on counters are incorrect	
25	Microprocessor watchdog fault	faulty operation component failure	Reset the fault and restart. Should the fault re-occur, contact the distributor near to you. For local contacts, go to: http://drives.danfoss.com/danfoss-drives/local-contacts/
26	Start-up prevented	Start-up of the drive has been prevented.	Cancel prevention of start-up.
29	Thermistor fault	The thermistor input of option board has detected increase of the motor temperature	Check motor cooling and loading Check thermistor connection (If thermistor input of the option board is not in use it has to be short circuited)
31	IGBT temperature (hardware)	IGBT Inverter Bridge overtemperature protection has detected too high a short term overload current	Check loading. Check motor size.
32	Fan cooling	Cooling fan of the inverter does not start, when ON command is given.	Contact the distributor near to you. For local contacts, go to: http://drives.danfoss.com/danfoss-drives/local-contacts/
34	CAN bus communication	Sent message not acknowledged.	Ensure that there is another device on the bus with the same configuration.
36	Control unit	NXS Control Unit can not control NXP Power Unit and vice versa	Change control unit
37	Device changed (same type)	Option board or control unit changed. Same type of board or same power rating of drive.	Reset Note: No fault time data record!
38	Device added (same type)	Option board or drive added. Drive of same power rating or same type of board added.	Reset Note: No fault time data record!

Fault code	Fault	Possible cause	Correcting measures
39	Device removed	Option board removed. Drive removed.	Reset Note: No fault time data record!
40	Device unknown	Unknown option board or drive.	Contact the distributor near to you. For local contacts, go to: http://drives.danfoss.com/danfoss-drives/local-contacts/
41	IGBT temperature	IGBT Inverter Bridge overtemperature protection has detected too high a short term overload current	Check loading. Check motor size.
42	Brake resistor overtemperature	Brake resistor overtemperature protection has detected too heavy braking	Set the deceleration time longer. Use external brake resistor.
43	Encoder fault	Note the exceptional Fault data record. See 7.3.4.3. Additional codes: 1 = Encoder 1 channel A is missing 2 = Encoder 1 channel B is missing 3 = Both encoder 1 channels are missing 4 = Encoder reversed	Check encoder channel connections. Check the encoder board.
44	Device changed (different type)	Option board or control unit changed. Option board of different type or different power rating of drive.	Reset Note: No fault time data record! Note: Application parameter values restored to default.
45	Device added (different type)	Option board or drive added. Option board of different type or drive of different power rating added.	Reset Note: No fault time data record! Note: Application parameter values restored to default.
50	Analogue input (sel. signal range 4 to 20 mA)	Current at the analogue input is < 4mA. control cable is broken or loose signal source has failed	Check the current loop circuitry.
51	External fault	Digital input fault.	
52	Keypad communication fault	There is no connection between the control keypad and the inverter.	Check keypad connection and possible keypad cable.
53	Fieldbus fault	The data connection between the fieldbus Master and the fieldbus board is broken	Check installation. If installation is correct, contact the distributor near to you. For local contacts, go to: http://drives.danfoss.com/danfoss-drives/local-contacts/
54	Slot fault	Defective option board or slot	Check board and slot. Contact the distributor near to you. For local contacts, go to: http://drives.danfoss.com/danfoss-drives/local-contacts/
56	PT100 board temp. fault	Temperature limit values set for the PT100 board parameters have been exceeded	Find the cause of temperature rise

Table 7-3. Fault codes

7.3.4.3 Fault time data record

When a fault occurs, the information described in Chapter 7.3.3.4 is displayed. By pressing *Menu button right*, you will enter the *Fault time data record menu* indicated by T.1→T.#. In this menu, some selected important data valid at the time of the fault are recorded. This feature will help the user or the service person in determining the cause of the fault.

The data available are:

T.1	Counted operation days (Fault 43: Additional code)	(d)
T.2	Counted operation hours (Fault 43: Counted operation days)	(hh:mm:ss) (d)
T.3	Output frequency (Fault 43: Counted operation hours)	Hz (hh:mm:ss)
T.4	Motor current	A
T.5	Motor voltage	V
T.6	Motor power	%
T.7	Motor torque	%
T.8	DC voltage	V
T.9	Unit temperature	°C
T.10	Run status	
T.11	Direction	
T.12	Warnings	
T.13	0-speed*	

Table 7-4. Fault time recorded data

* Tells the user if the drive was at zero speed (< 0.01 Hz) when the fault occurred

Real time record

If real time is set to run on the inverter, the data items T1 and T2 will appear as follows:

T.1	Counted operation days	yyyy-mm-dd
T.2	Counted operation hours	hh:mm:ss,sss

7.3.5 Fault history menu (M5)

You can enter the *Fault history menu* from the *Main menu* by pressing *Menu button right* when the location indication **M5** is visible on the first line of the keypad display.

All faults are stored in the *Fault history menu* where you can browse them with the *Browser buttons*. Additionally, the *Fault time data record* pages (see Chapter 7.3.4.3) are accessible for each fault. You can return to the previous menu any time by pressing *Menu button left*.

The memory of the inverter can store a maximum of 30 faults in order of appearance. The number of faults currently in the fault history is shown on the value line of the main page (**H1→H#**). The order of the faults is indicated by the location indication in the upper left corner of the display. The latest fault is indicated by F5.1, the one before that by F5.2 and so on. If there are 30 uncleared faults in the memory, the next fault will erase the oldest fault from the memory.

Pressing the *enter* button for about 2 to 3 seconds resets the whole fault history. The symbol **H#** will change to **0**.

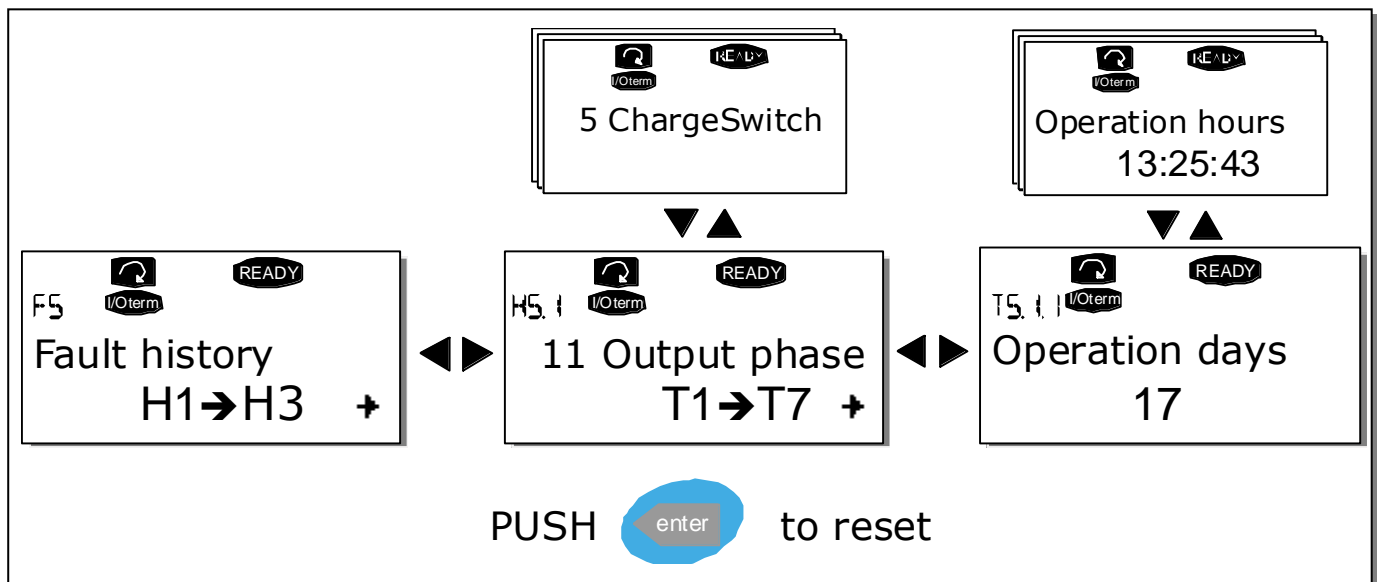

Figure 7-8. Fault history menu

7.3.6 System menu (M6)

You can enter the *System menu* from the *Main menu* by pressing *Menu button right* when the location indication **M6** is visible on the first line of the keypad display.

The controls associated with the general use of the inverter, such as application selection, customised parameter sets or information about the hardware and software are located under the *System menu*. The number of submenus and subpages is shown with the symbol S (or P) on the value line.

Page 70 has a table of the functions available in the System menu.

System menu functions

Code	Function	Min	Max	Unit	Default	Cust	Selections
S6.1	Selection of language				English		English Deutsch Suomi Svenska Italiano
S6.2	Application selection				Basic Application		Basic Application Standard Application Local/Remote control Appl. Multi-Step Application PID Control Application Multi-Purpose Control Appl. Pump and Fan Control Appl.
S6.3	Copy parameters						
S6.3.1	Parameter sets						Load factory defaults Store set 1 Load set 1 Store set 2 Load set 2
S6.3.2	Load to keypad						All parameters
S6.3.3	Load from keypad						All parameters All but motor parameters Application parameters
P6.3.4	Parameter backup				Yes		No Yes
S6.4	Parameter comparison						
S6.4.1	Set1				Not used		
S6.4.2	Set2				Not used		
S6.4.3	Factory settings						
S6.4.4	Keypad set						
S6.5	Safety						
S6.5.1	Password				Not used		0=Not used
P6.5.2	Parameter locking				Change Enabled		Change Enabled Change Disabled
S6.5.3	Start-up wizard						No Yes
S6.5.4	Multimonitoring items				Change Enabled		Change Enabled Change Disabled
S6.6	Keypad settings						
P6.6.1	Default page						
P6.6.2	Default page/OM						
P6.6.3	Timeout time	0	65535	s	30		
P6.6.4	Contrast	0	31		18		
P6.6.5	Backlight time	Always	65535	min	10		
S6.7	Hardware settings						
P6.7.1	Internal brake resistor				Connected		Not connected Connected
P6.7.2	Fan control function				Continuous		Continuous Temperature
P6.7.3	HMI acknowledg.	200	5000	ms	200		
P6.7.4	HMI: no. of retries	1	10		5		
S6.8	System information						
S6.8.1	Total counters						
C6.8.1.1.	MWh counter			kWh			
C6.8.1.2.	Operation day counter						
C6.8.1.3.	Operation hour						

	counter						
S6.8.2	Trip counters						
T6.8.2.1	MWh counter			kWh			
T6.8.2.2	Clear MWh counter						
T6.8.2.3	Operation day counter						
T6.8.2.4	Operation hour counter						
T6.8.2.5	Clear operation hour counter						
S6.8.3	Software information						
S6.8.3.1	Software package						
S6.8.3.2	System software version						
S6.8.3.3	Firmware interface						
S6.8.3.4	System load						
S6.8.4	Applications						
S6.8.4.#	<i>Name of application</i>						
D6.8.4.#.1	Application ID						
D6.8.4.#.2	Applications: version						
D6.8.4.#.3	Applications: firmware interface						
S6.8.5	Hardware						
I6.8.5.1	Unit power						
I6.8.5.2	Unit voltage						
E6.8.5.3	Brake chopper						
E6.8.5.4	Brake resistor						
S6.8.6	Expander boards						
S6.8.7	Debug menu						For Application programming only. Contact the factory to get instructions.

Table 7-5. System menu functions

7.3.6.1 Selection of language

The VACON® control keypad offers you the possibility to control the inverter through the keypad in the language of your choice.

Locate the language selection page under the *System menu*. Its location indication is **S6.1**. Press *Menu button right* once to enter the edit mode. As the name of the language starts to blink you can select another language for the keypad texts. Confirm with the *enter* button. The blinking stops and all text information on the keypad is presented in the selected language.

You can return to the previous menu any time by pressing *Menu button left*.

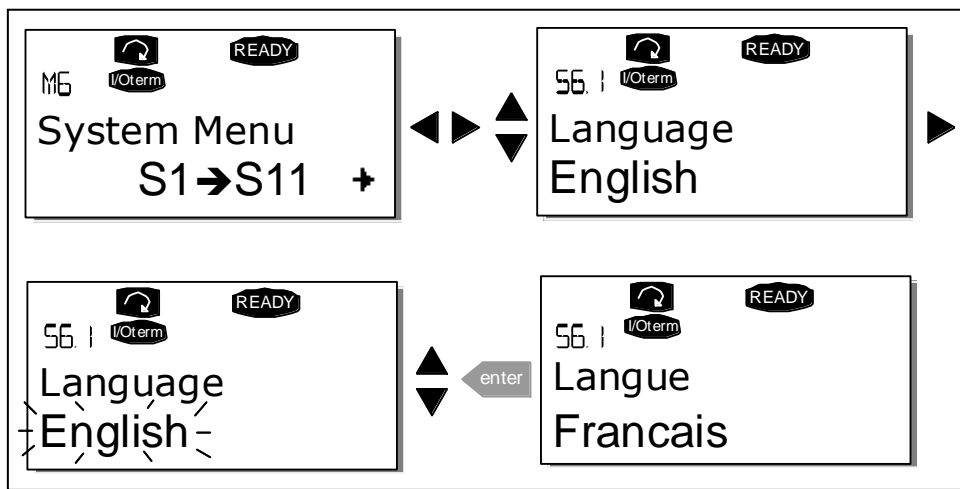

Figure 7-9. Selection of language

7.3.6.2 Application selection

The user can select the desired application on the *Application selection page (S6.2)*. To enter the page, press *Menu button right* on the first page of the *System menu*. To change the application, press *Menu button right* once more. The name of the application starts to blink. Now you can browse the applications with the *Browser buttons* and select the desired application with the *enter* button.

After application change, you will be asked if you want the parameters of the **new** application to be uploaded to the keypad. If you want to do this, press the *enter* button. Pressing any other button leaves the parameters of the **previously** used application saved in the keypad. For more information, see Chapter .

For more information about the Application Package, see VACON® NX Application Manual.

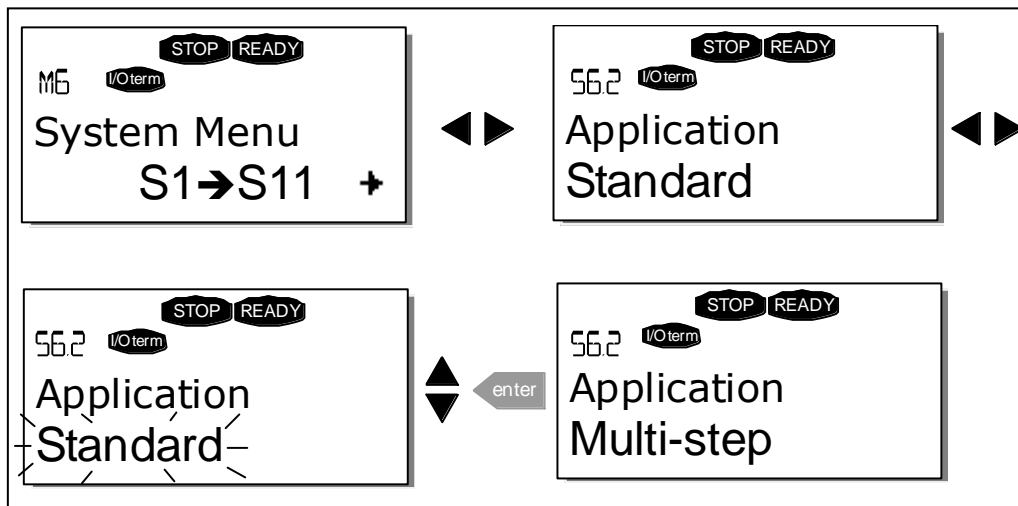

Figure 7-10. Change of application

7.3.6.3 Copy parameters

The parameter copy function is used when the operator wants to copy one or all parameter groups from one drive to another. All the parameter groups are first *uploaded* to the keypad, then the keypad is connected to another drive and then the parameter groups are *downloaded* to it (or possibly back to the same drive). For more information, see page 74.

Before any parameters can be successfully copied from one drive to another, the **drive** has to be **stopped** when the parameters are downloaded to it:

The parameter copy menu (S6.3) contains four functions:

Parameter sets (S6.3.1)

The user can reload the factory default parameter values and store and load two customised parameter sets (all parameters included in the application).

On the *Parameter sets* page (S6.3.1), press *Menu button right* to enter the *edit mode*. The text *LoadFactDef* begins to blink and you can confirm the loading of factory defaults by pressing the *enter* button. The drive resets automatically.

Alternatively, you can choose any other storing or loading functions with the *Browser buttons*. Confirm with the *enter* button. Wait until 'OK' appears on the display.

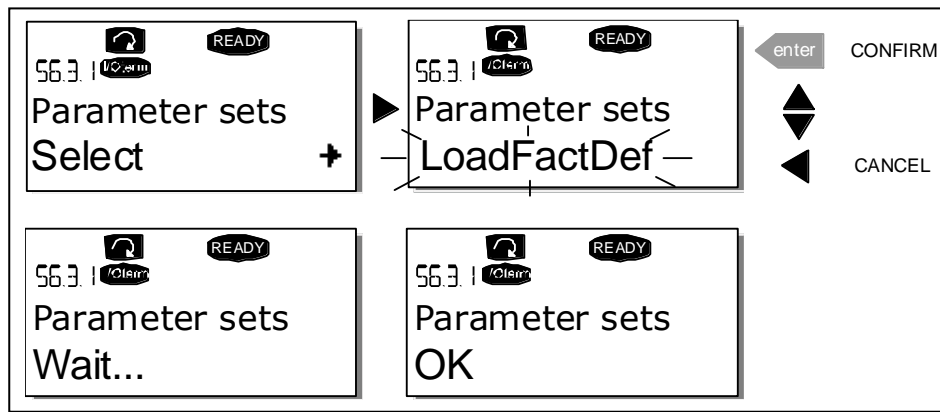

Figure 7-11. Storing and loading of parameter sets

Upload parameters to keypad (To keypad, S6.3.2)

This function uploads **all** existing parameter groups to the keypad provided that the drive is stopped.

Enter the *To keypad* page (S6.3.2) from the *Parameter copy menu*. Pressing *Menu button right* takes you to the edit mode. Use the *Browser buttons* to select the option *All parameters* and press the *enter* button. Wait until 'OK' appears on the display.

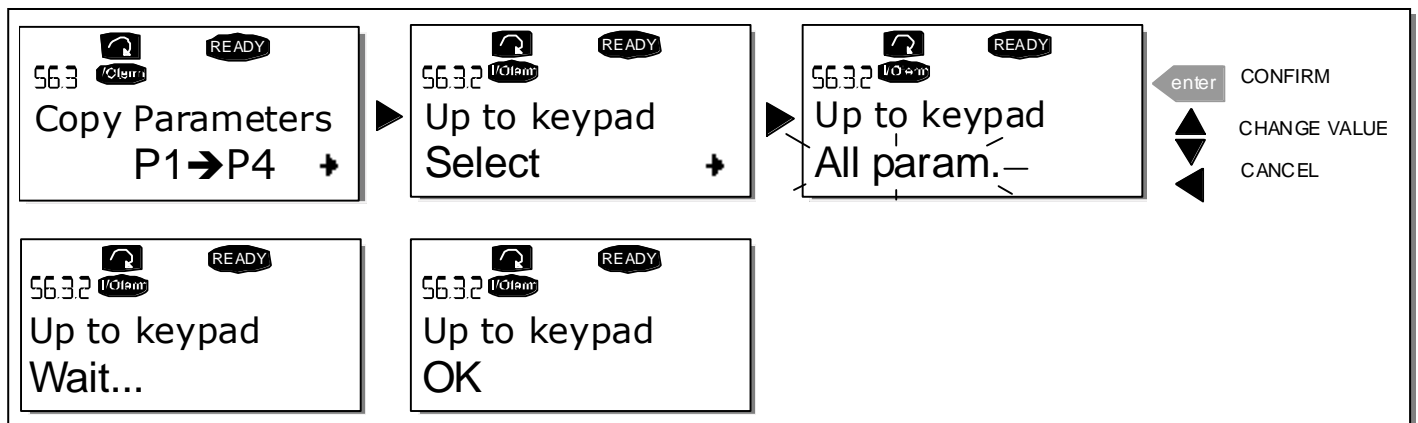

Figure 7-12. Parameter copy to keypad

Download parameters to drive (From keypad, S6.3.3)

This function downloads **one or all** parameter groups uploaded to the keypad to a drive provided that the drive is in STOP status.

Enter the *To keypad* page (S6.3.2) from the *Parameter copy menu*. Pressing the *Menu button right* takes you to the edit mode. Use the *Browser buttons* to select either *All parameters*, *All but motor parameters* or *Application parameters* and press the *Enter button*. Wait until 'OK' appears on the display.

The procedure to download the parameters from keypad to drive is similar to that of from drive to keypad. See Figure 7-12.

Automatic parameter backup (P6.3.4)

On this page you can activate or inactivate the parameter backup function. Enter the edit mode by pressing *Menu button right*. Select *Yes* or *No* with the *Browser buttons*.

When the Parameter backup function is activated VACON® NX control keypad makes a copy of the parameters of the presently used application. When applications are changed, you will be asked if you wish the parameters of the **new** application to be uploaded to the keypad. If you want to do this, press the *enter* button. If you wish to keep the copy of the parameters of the **previously used** application saved in the keypad, press any other button. Now you will be able to download these parameters to the drive following the instructions given in Chapter 7.3.6.3.

If you want the parameters of the new application to be automatically uploaded to the keypad you have to do this for the parameters of the new application once on page 6.3.2 as instructed. **Otherwise the panel will always ask for the permission to upload the parameters.**

Note: Parameters saved in the parameter settings on page S6.3.1 will be deleted when applications are changed. If you want to transfer the parameters from one application to another, you have to upload them first to the keypad.

7.3.6.4 Parameter comparison

In the *Parameter comparison* submenu (S6.4), you can compare the **actual parameter values** to the values of your customised parameter sets and those loaded to the control keypad.

You can compare the parameter by pressing *Menu button right* in the *Compare parameters submenu*. The actual parameter values are first compared to those of the customised parameter Set1. If no differences are detected, '0' is displayed on the lowermost line. If any of the parameter values differ from those of Set1, the number of the deviations is displayed together with symbol P (for example, P1→P5 = five deviating values). By pressing *Menu button right* once more, you can enter pages where you can see both the actual value and the value it was compared to. In this display, the value on the description line (in the middle) is the default value and the one on the value line (lowermost) is the edited value. Furthermore, you can also edit the actual value with the *Browser buttons* in the *edit mode* which you can enter by pressing *Menu button right* once.

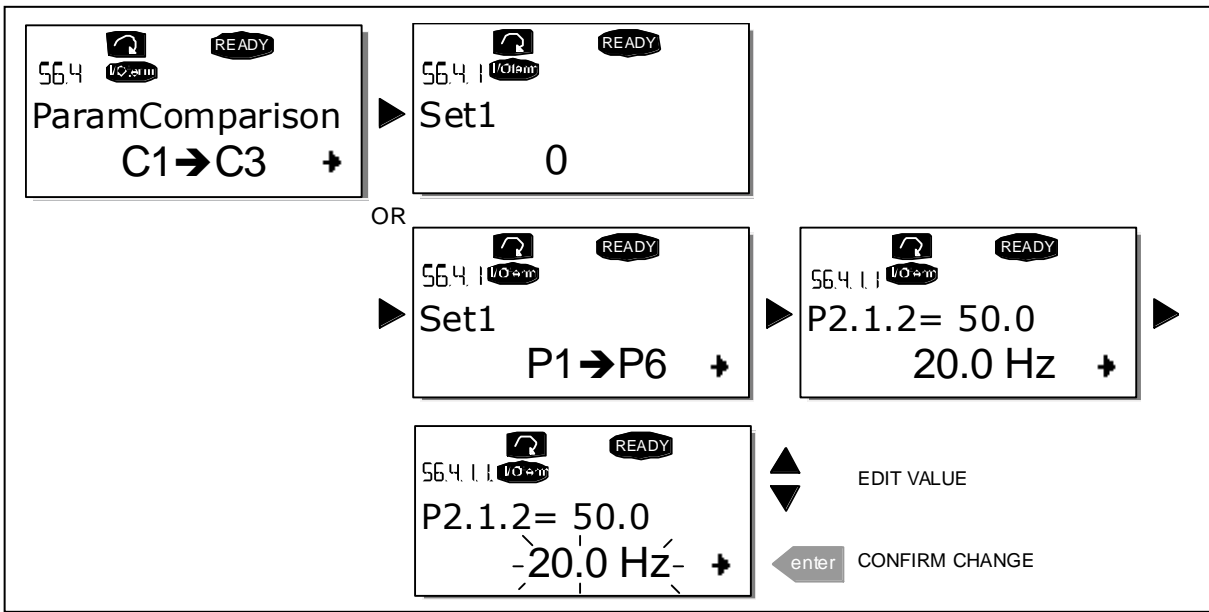

Figure 7-13. Parameter comparison

7.3.6.5 Safety

NOTE: The *Security submenu* is protected with a password. Store the password in a safe place!

Password (S6.5.1)

The application selection can be protected against unauthorised changes with the Password function (S6.5.1).

By default, the password function is not in use. If you want to activate the function, enter the edit mode by pressing *Menu button right*. A blinking zero appears in the display and you can set a password with the *Browser buttons*. The password can be any number between 1 and 65535.

Note that you can also set the password by digits. In the edit mode, push *Menu button right* again and another zero appears on the display. Set ones first. To set the tens, press *Menu button right*, and so on. Confirm the password with the *enter* button. After this, you have to wait until the *Timeout time* (P6.6.3) (see page 79) has expired before the password function is activated.

If you try to change applications or the password itself, you will be prompted for the current password. Enter the password with the *Browser buttons*.

You can deactivate the password function by entering the value 0.

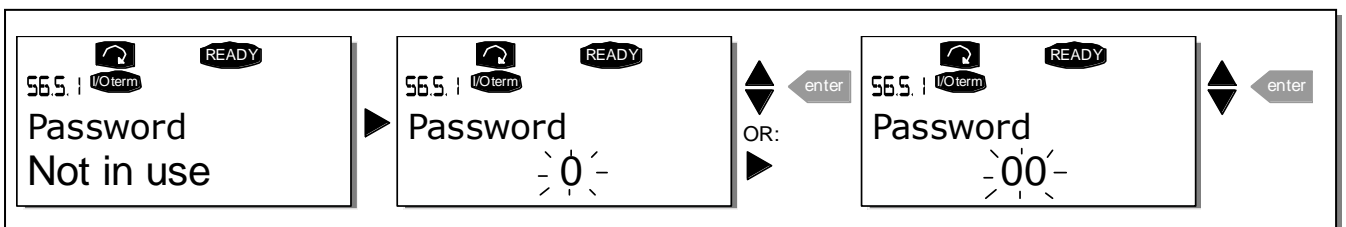

Figure 7-14. Password setting

Note! Store the password in a safe place! No changes can be made unless a valid password is entered.

Parameter lock (P6.5.2)

This function allows the user to prohibit changes to the parameters.

If the parameter lock is activated, the text **locked** will appear on the display if you try to edit a parameter value.

NOTE: This function does not prevent unauthorised editing of parameter values.

Enter the edit mode by pressing *Menu button right*. Use the *Browser buttons* to change the parameter lock status. Confirm the change with the *enter* button or go back to the previous level by pressing *Menu button left*.

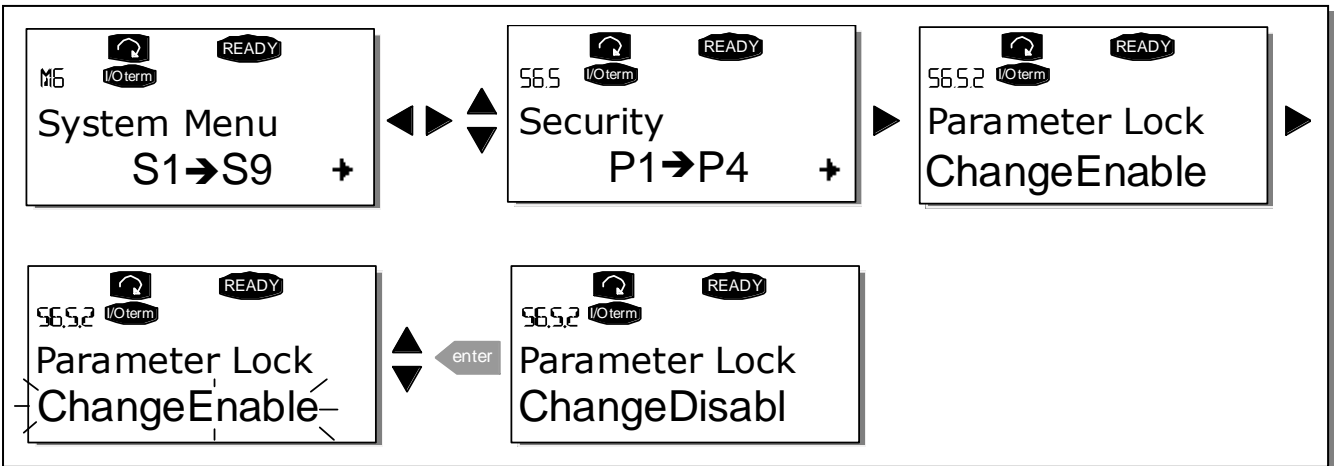

Figure 7-15. Parameter locking

Start-up wizard (P6.5.3)

The Start-up wizard facilitates the commissioning of the inverter. If active, the Start-up wizard prompts the operator for the language and application of his/her choice and then displays the first menu or page.

Activating the Start-up wizard: In the System Menu, find page P6.5.3. Press *Menu button right* once to enter the edit mode. Use the *Browser buttons* to select *Yes* and confirm the selection with the *enter* button. If you want to deactivate the function, follow the same procedure and give the parameter value *No*.



Figure 7-16. Activation of Start-up wizard

Multimonitoring items (P6.5.4)

VACON® alphanumeric keypad features a display where you can monitor up to three actual values at the same time (see Chapter 7.3.1 and Chapter *Monitoring values* in the manual of the application you are using). On page P6.5.4 of the System Menu, you can define whether the operator can replace the values monitored with other values. See below.

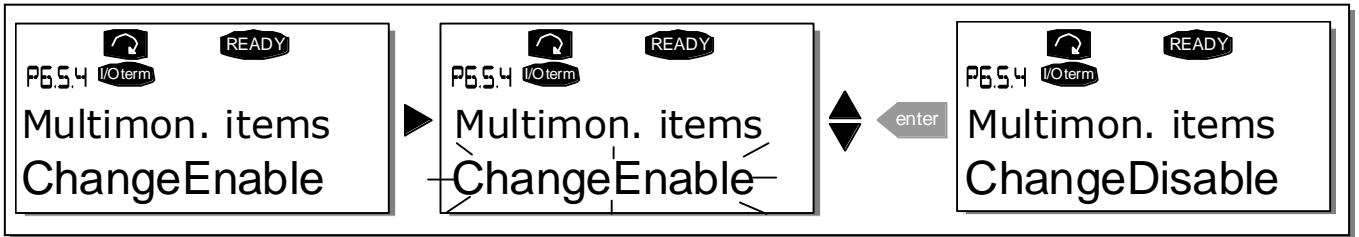

Figure 7-17. Disabling the change of multimonitoring items

7.3.6.6 Keypad settings

In the Keypad settings submenu under the System menu, you can further customise your inverter operator interface.

Locate the Keypad setting submenu (S6.6). Under the submenu, there are four pages (P#) associated with the keypad operation:

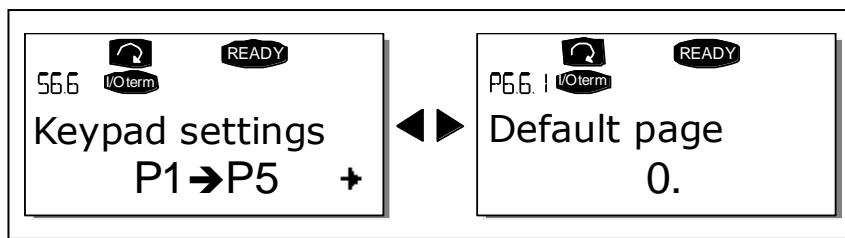

Figure 7-18. Keypad settings submenu

Default page (P6.6.1)

Here you can set the location (page) to which the display automatically moves when the *Timeout time* (see below) has expired or the power is switched on to the keypad.

If the *Default page* is 0, the function is not activated i.e. the latest displayed page remains on the keypad display. Pressing *Menu button right* takes you to the edit mode. Change the number of the Main menu with the *Browser buttons*. To edit the number of the submenu/page, press *Menu button right*. If the page you want to move to by default is at the third level, repeat the procedure. Confirm the new default page with the *enter* button. You can return to the previous menu at any time by pressing *Menu button left*.

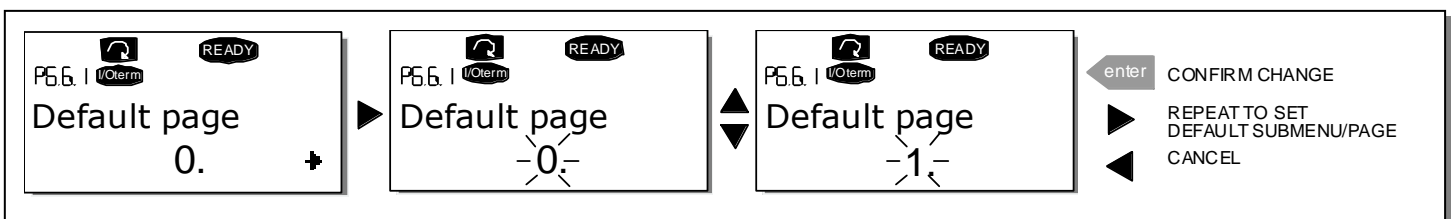

Figure 7-19. Default page function

Default page in the operating menu (P6.6.2)

Here you can set the location (page) in the *Operating menu* (in special applications only) to which the display automatically moves to when the set *Timeout time* (see below) has expired or the power is switched on to the keypad.

See how to set the Default page in the above figure.

Timeout time (P6.6.3)

The Timeout time setting defines the time after which the keypad display returns to the Default page (P6.6.1). (See previous page.)

Enter the edit mode by pressing *Menu button right*. Set the desired timeout time and confirm it with the *enter* button. You can return to the previous menu at any time by pressing *Menu button left*.

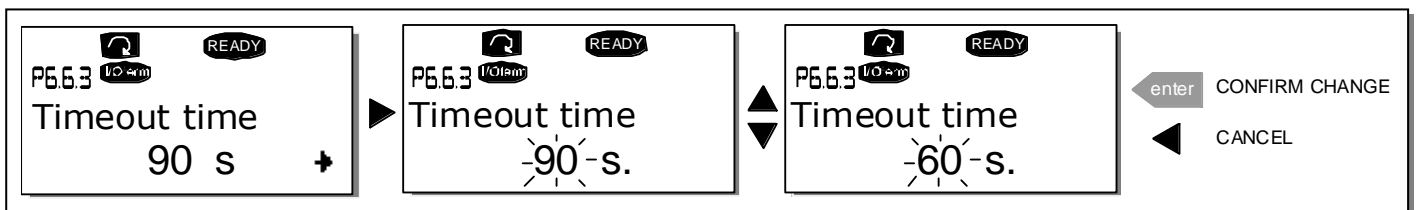

Figure 7-20. Timeout time setting

Note: If the *Default page* value is 0 the *Timeout time* setting has no effect.

Contrast adjustment (P6.6.4)

In case the display is unclear, you can adjust its contrast through the same procedure as for the timeout time setting (see above).

Backlight time (P6.6.5)

By giving a value for the *Backlight time*, you can determine how long the backlight stays on before going out. You can select any time between 1 and 65535 minutes or 'Forever'. For the value setting procedure, see Timeout time (P6.6.3).

7.3.6.7 Hardware settings

NOTE: *The Hardware settings submenu is protected with a password. Store the password in a safe place!*

In the *Hardware settings* submenu (S6.7) under the System menu, you can further control some functions of the hardware in your inverter. The functions available in this menu are **Internal brake resistor connection**, **Fan control**, **HMI acknowledge timeout** and **HMI retry**.

Internal brake resistor connection (P6.7.1)

This function tells the inverter, whether the internal brake resistor is connected or not. If you have ordered the inverter with an internal brake resistor, the default value of this parameter is *Connected*. However, if it is necessary to increase braking capacity by installing an external brake resistor, or if the internal brake resistor is disconnected for another reason, it is advisable to change the value of this function to *Not conn.* in order to avoid unnecessary fault trips.

Enter the edit mode by pressing *Menu button right*. You can change the brake resistor information with the *Browser buttons*. Confirm the change with the *enter* button or return to the previous level with *Menu button left*.

Note! The brake resistor is available as optional equipment for all classes. It can be installed internally in classes FR4 to FR6.

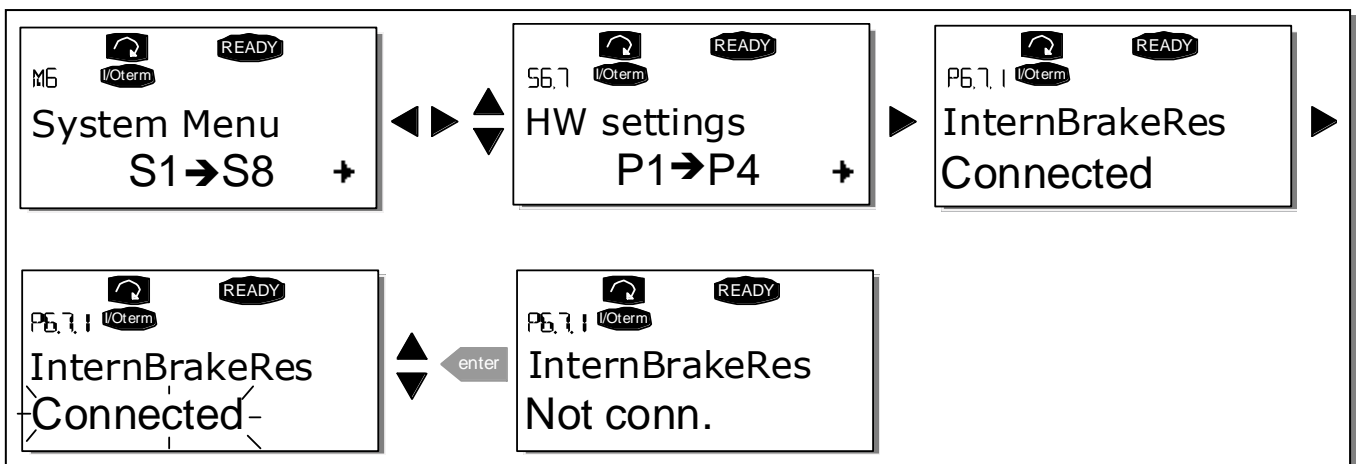

Figure 7-21. Internal brake resistor connection

Fan control (P6.7.2)

This function allows you to control the cooling fan of the inverter. You can set the fan to run continuously when the power is switched on or depending on the temperature of the unit. If the latter function has been selected, the fan is switched on automatically when the heatsink temperature reaches 60°C. The fan receives a stop command when the heatsink temperature falls to 55°C. After the command, the fan runs for approximately 1 minute before stopping. The same happens after switching on the power and after changing the value from *Continuous* to *Temperature*.

Note! The fan runs always when the drive is in RUN state.

To change the value: Enter the edit mode by pressing *Menu button right*. The value starts blinking. Use the *Browser buttons* to change the fan mode and confirm the change with the *enter* button. If you do not want to change the value, return to the previous level with *Menu button left*. See Figure 7.21 .

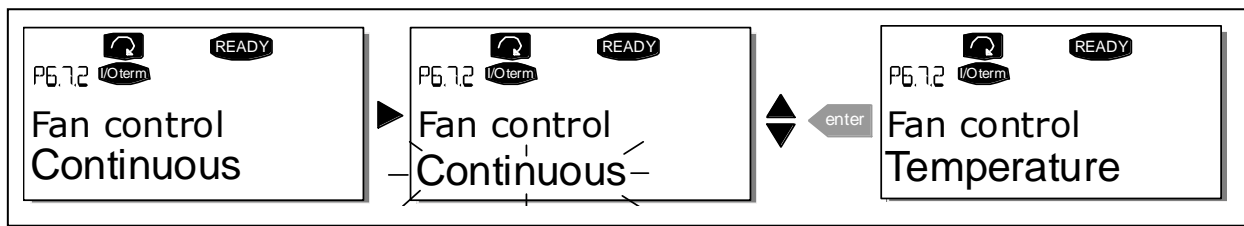

Figure 7-22. Fan control function

HMI acknowledge timeout (P6.7.3)

This function allows the user to change the timeout of the HMI acknowledgement time. The inverter waits for the HMI acknowledgment in accordance with the value of this parameter.

Note! If the inverter has been connected to the PC **with a normal cable**, the **default values** of parameters 6.7.3 and 6.7.4 (200 and 5) **must not be changed**.

If the inverter has been connected to the PC via a modem and there is a delay in transferring messages, the value of parameter 6.7.3 must be set according to the delay as follows:

Example:

- Transfer delay between the inverter and the PC = 600 ms
- The value of par. 6.7.3 is set to 1200 ms (2 x 600, sending delay + receiving delay)
- The corresponding setting shall be entered in the [Misc] part of the file NCDrive.ini:
 - Retries = 5
 - AckTimeOut = 1200
 - TimeOut = 6000
- It must also be considered that intervals shorter than the AckTimeOut time cannot be used in NC-Drive monitoring.

Enter the edit mode by pressing *Menu button right*. The current value starts to blink. Use the *Browser buttons* to change the acknowledgement time. Confirm the change with the *enter* button or return to the previous level with *Menu button left*.

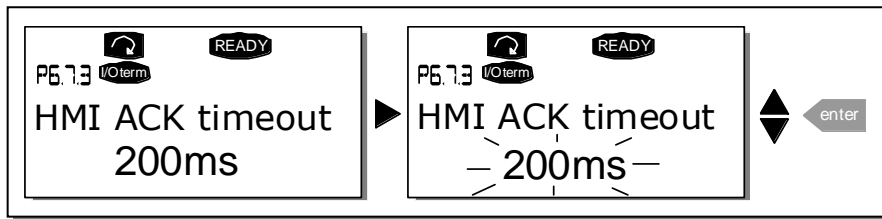

Figure 7-23. HMI acknowledge timeout

Number of retries to receive HMI acknowledgement (P6.7.4)

With this parameter you can set the number of times the drive will try to receive acknowledgement if it does not receive acknowledgement within the acknowledgement time (P6.7.3) or if the received acknowledgement is faulty.

You can change value through the same procedure as for P6.7.3 (see above).

Note! Changes to P6.7.3 and P6.7.4 become effective after the next start-up.

7.3.6.8 System info

In the *System info* submenu (S6.8) you can find inverter-related hardware and software information.

You can enter the *System info* submenu by pressing *Menu button right*. You can now browse the submenu pages with the *Browser buttons*.

Total counters

The *Total counters menu* (S6.8.1) contains information on the inverter operation times i.e. the total number of MWh, operation days and operation hours. Unlike the counters in the *Trip counters menu*, these counters cannot be reset.

Note! The *Power On time counter* (days and hours) runs always when the power is on.

Page	Counter
C6.8.10.1.	MWh counter
C6.8.10.2.	Operation day counter
C6.8.1.3.	Operation hour counter

Table 7-6. Counter pages

Trip counters

Trip counters (menu S6.8.2) are counters the values of which can be reset i.e. restored to zero. You can use the following resettable counters:

Note! The trip counters run only when the motor is running.

Page	Counter
T6.8.2.1	MWh counter
T6.8.2.3	Operation day counter
T6.8.2.4	Operation hour counter

Table 7-7. Resettable counters

The counters can be reset on pages 6.8.2.2 (Clear MWh counter) and 6.8.2.5 (Clear Operation time counter).

Example: When you want to reset the operation counters you should do the following:

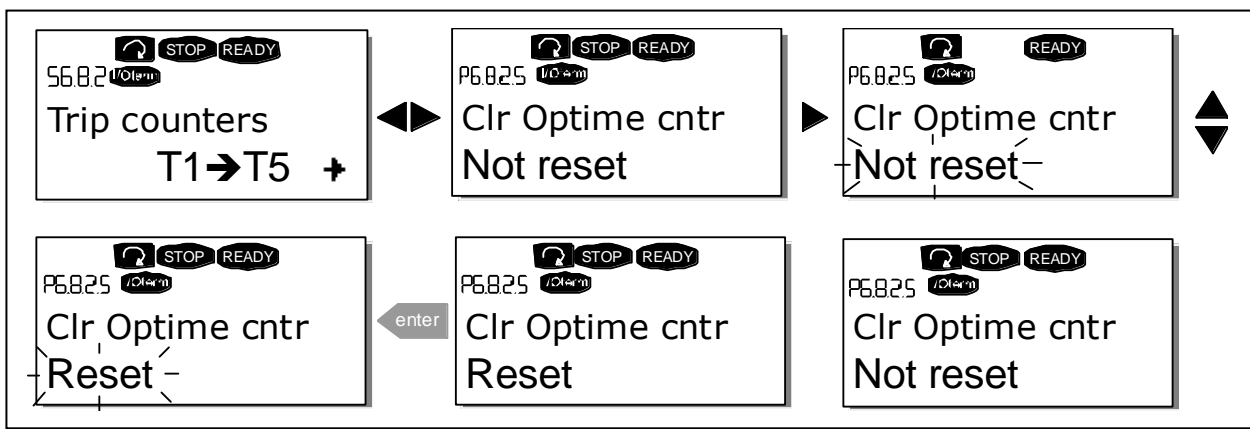

Figure 7-24. Counter reset

Software (S6.8.3)

The Software information page includes information on the following inverter software related topics:

Page	Content
6.8.3.1	Software package
6.8.3.2	System software version
6.8.3.3	Firmware interface
6.8.3.4	System load

Table 7-8. Software information pages

Applications (S6.8.4)

At location S6.8.4, you can find the Applications submenu containing information on the application currently in use and all other applications loaded into the inverter. The following information is available:

Page	Content
6.8.4.#	Name of application
6.8.4.#.1	Application ID
6.8.4.#.2	Version
6.8.4.#.3	Firmware interface

Table 7-9. Applications information pages

In the Applications information page, press *Menu button right* to enter the Application pages of which there are as many as there are applications loaded into the inverter. Locate the desired application with the *Browser buttons* and then enter the Information pages with *Menu button right*. Use the *Browser buttons* to see the different pages.

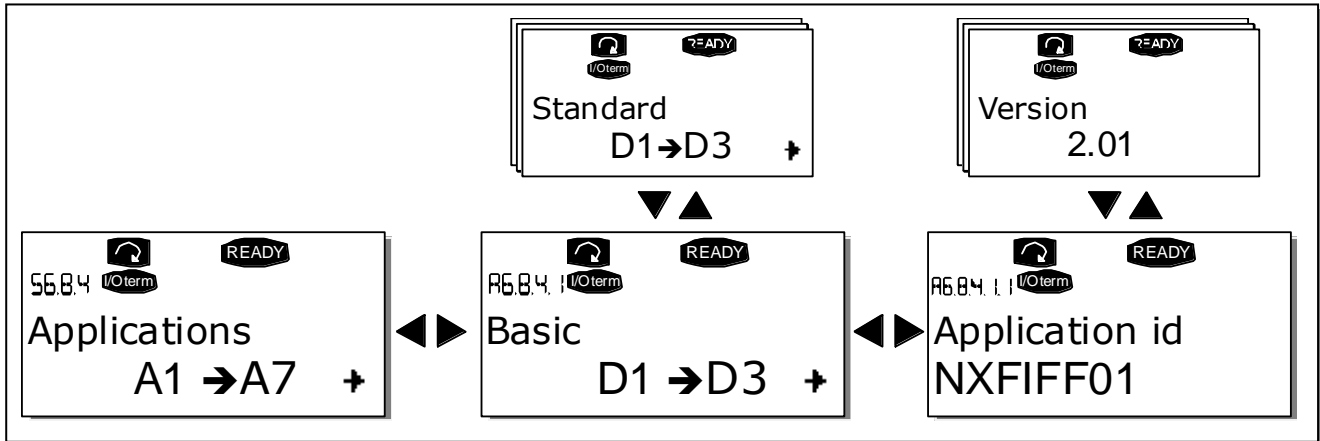

Figure 7-25. Applications info submenu

Hardware (S6.8.5)

The *Hardware* information page provides information on the following hardware-related topics:

Page	Content
6.8.5.1	Nominal power of the unit
6.8.5.2	Nominal voltage of the unit
6.8.5.3	Brake chopper
6.8.5.4	Brake resistor

Table 7-10. Hardware information pages

Expander boards (S6.8.6)

The *Expander boards* submenu contains information about the basic and option boards. (See Chapter 6.2)

You can check the status of each board slot by entering the Expander boards page with *Menu button right*. Use the *Browser buttons* to view the status of each board slot. The description line of the keypad will display the type of the expansion board and the text 'Run' is shown below it. If no board is connected to the slot the text 'no board' will be shown. If a board is connected to a slot but the connection is lost for some reason, the text 'no conn.' is displayed. For more information, see Chapter 6.2, Figure 6-7.

For more information on expander board related parameters, see Chapter 7.3.7.

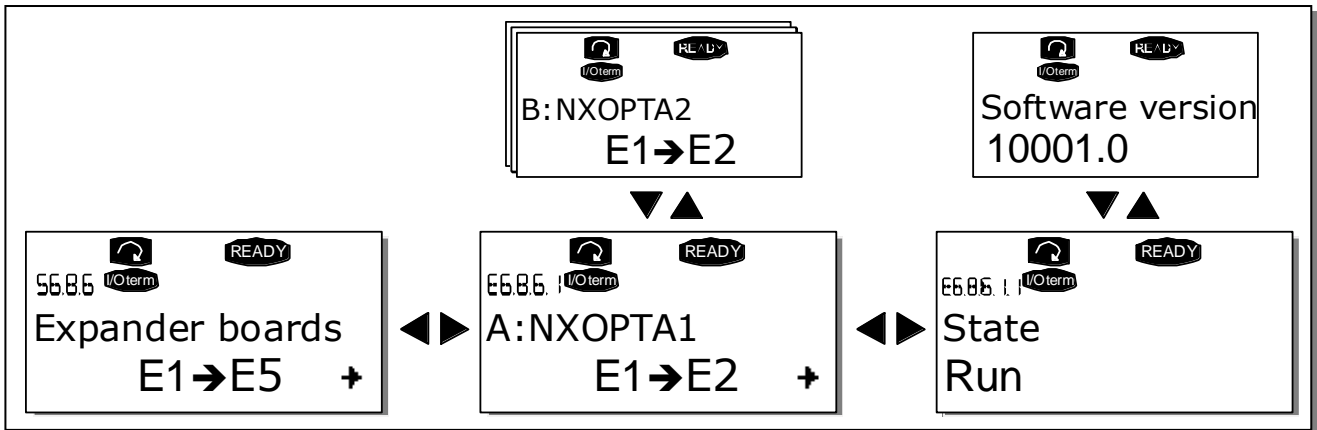

Figure 7-26. Expander board information menus

7.3.7 Expander board menu (M7)

In the *Expander board menu* the user can 1) see the expander boards connected to the control board and 2) see and edit the parameters associated with the expander boards.

Go to the next menu level (G#) with *Menu button right*. At this level, you can browse through slots A to E (see page 43) with the *Browser buttons* to see which expander boards are connected to the control board. On the lowermost line of the display, you will also see the number of parameters associated with the board. You can view and edit the parameter values as described in Chapter 7.3.2. See Table 7-11 and Figure 7-27.

Expander board parameters

Code	Parameter	Min	Max	Default	Cust	Selections
P7.1.1.1	AI1 mode	1	5	3		1=0...20 mA 2=4...20 mA 3=0...10 V 4=2...10 V 5=-10...+10 V
P7.1.1.2	AI2 mode	1	5	1		See P7.1.1.1
P7.1.1.3	AO1 mode	1	4	1		1=0...20 mA 2=4...20 mA 3=0...10 V 4=2...10 V

Table 7-11. Expander board parameters (board NXOPTA1)

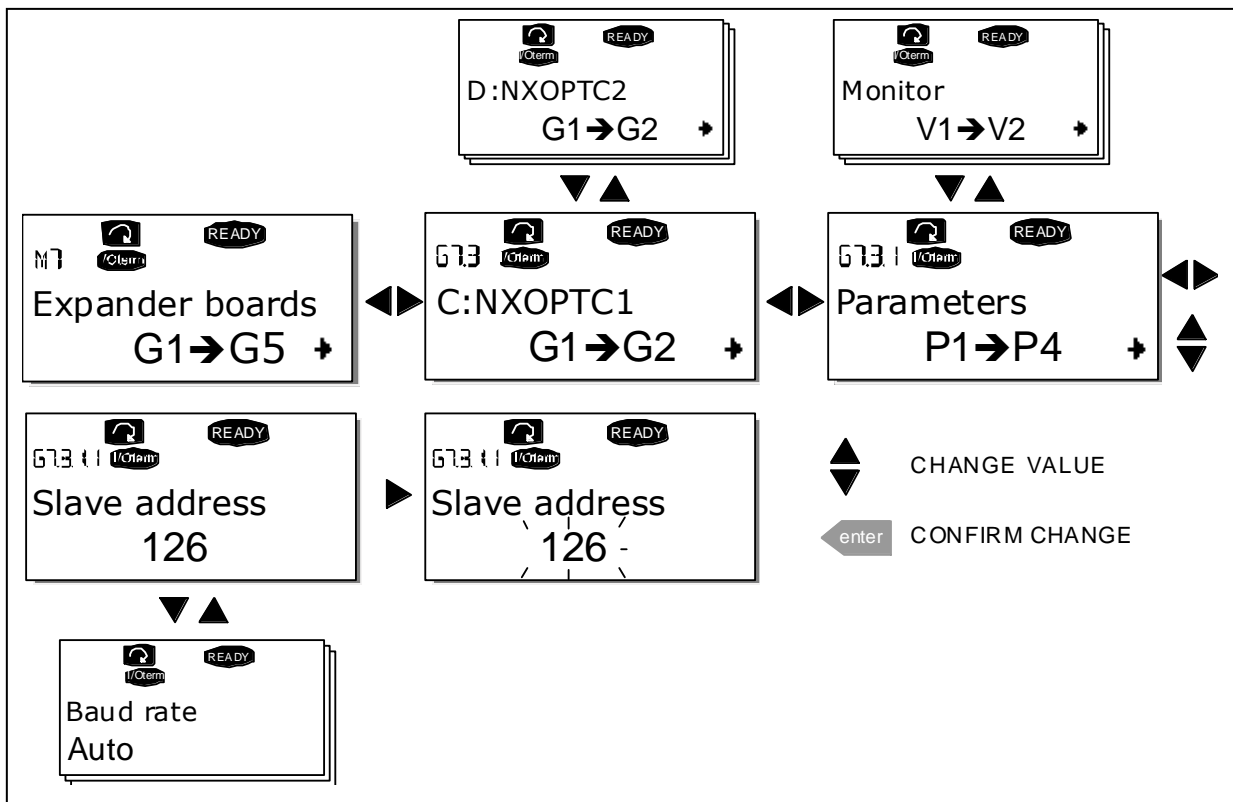

Figure 7-27. Expander board information menu



7.4 Further keypad functions

The VACON® NX control keypad contains additional application-related functions. See VACON® NX Application Package for more information.

8. COMMISSIONING

8.1 Safety

Before commissioning, note the following directions and warnings:

	1	Internal components and circuit boards of the inverter (except for the galvanically isolated I/O terminals) are live when VACON® NX is connected to mains potential. Coming into contact with this voltage is extremely dangerous and may cause death or severe injury.
	2	The motor terminals U, V, W and the DC-link/brake resistor terminals+/- are live when VACON® NX inverter is connected to DC supply, even if the motor is not running.
	3	The control I/O-terminals are isolated from the mains potential. However, the relay outputs and other I/O-terminals may have a dangerous control voltage present even when VACON® NX is disconnected from DC supply.
	4	Do not make any connections when the inverter is connected to the DC supply.
	5	After having disconnected the inverter, wait until the fan stops and the indicators on the keypad go out (if no keypad is attached see the indicator through the keypad base). Wait 5 more minutes before doing any work on VACON® NX connections. Do not open the cover before the time has expired.
	6	Before connecting the inverter to DC supply make sure that the VACON® NX front cover is closed.
	7	When running, the side of inverter FR8 is burning hot. Do not touch it with bare hands!
	8	When running, the back of inverter FR6 is burning hot. Therefore it MUST NOT be mounted onto a surface which is not fireproof.

8.2 Commissioning the inverter

- 1 Read carefully the safety instructions in Chapter 1 and above and follow them.
- 2 After the installation, make sure that:
 - both the inverter and the motor are grounded
 - the DC supply and motor cables comply with the requirements given in Chapter 6.1.1.
 - the control cables are located as far as possible from the power cables (see Chapter 6.1.2, step 2) and the shields of the shielded cables are connected to protective earth (⊥). The wires may not touch the electrical components of the inverter.
 - the common inputs of digital input groups are connected to +24V or ground of the I/O terminal or the external supply.
- 3 Check the quality and quantity of cooling air (See Chapter 5.2 and Table 5-6).
- 4 Check the inside of the inverter for condensation.
- 5 Check that all Start/Stop switches connected to the I/O terminals are in **Stop** position.

- 6 Connect the inverter to DC supply.
- 7 Set the parameters of group 1 according to the requirements of your application (See VACON® All in One Application Manual). At least the following parameters should be set:
 - motor nominal voltage
 - motor nominal frequency
 - motor nominal speed
 - motor nominal current

You will find the values needed for the parameters on the motor rating plate.

- 8 Perform run test **without motor**

Perform either Test A or Test B:

A Controls from the I/O terminals:

Turn the Start/Stop switch to ON position.

Change the frequency reference (potentiometer)

*Check in the Monitoring menu **M1** that the value of Output frequency changes according to the change of frequency reference.*

Turn the Start/Stop switch to OFF position.

B Control from the control keypad:

Change the control from the I/O terminals to the keypad as advised in Chapter 7.3.3.1.

Press the START button on the keypad START.

Move over to the Keypad control menu M3 and Keypad Reference submenu (see Chapter

7.3.3.2) and change the frequency reference with the Browser buttons  .

*Check in Monitoring menu **M1** that the value of Output frequency changes according to the change of frequency reference.*

Press the STOP button on the keypad STOP.

- 9 Run the start-up tests without the motor being connected to the process. If this is not possible, make sure that running each test is safe prior to running it. Inform your co-workers of the tests.
 - a) *Switch off the DC supply voltage and wait until the drive has stopped as advised in Chapter 8.1, step 5.*
 - b) *Connect the motor cable to the motor and to the motor cable terminals of the inverter.*
 - c) *Make sure that all Start/Stop switches are in Stop positions.*
 - d) *Switch the supply voltage ON*
 - e) *Repeat test 8A or 8B.*

- 10 Connect the motor to the process (if the start-up test was run without the motor being connected)
 - a) *Before running the tests, make sure that this can be done safely.*
 - b) *Inform your co-workers of the tests.*
 - c) *Repeat test 8A or 8B.*

9. FAULT TRACING

When a fault is detected by the inverter control electronics, the drive is stopped and the symbol F together with the ordinal number of the fault, the fault code and a short fault description appear on the display. The fault can be reset with the *reset* button on the control keypad or via the I/O terminal. The faults are stored in the Fault history menu M5, which can be browsed. The table below contains all the fault codes.

The fault codes, their causes and correcting actions are presented in the table below. Shaded faults are A faults only. The items in white on black background present faults for which you can program different responses in the application, see parameter group Protections.

Fault code	Fault	Possible cause	Correcting measures
1	Overcurrent S1 = Hardware trip S3 = Current controller supervision S4 = User configured overcurrent limit exceeded	Inverter has detected too high a current ($>4 \cdot I_n$) in the motor cable: sudden heavy load increase short circuit in motor cables unsuitable motor	Check loading. Check motor. Check cables. Make an identification run.
2	Overvoltage S1 = Hardware trip S2 = Overvoltage control supervision	The DC-link voltage has exceeded the limits defined in too short a deceleration time high overvoltage spikes in supply Start/Stop sequence too fast	Set the deceleration time longer. Add a brake chopper or a brake resistor. Activate the overvoltage controller. Check the input voltage.
3	Earth fault	Current measurement has detected that the sum of motor phase current is not zero. insulation failure in cables or motor	Check motor cable and motor.
5	Charging switch	The charging switch is open, when the START command has been given. faulty operation component failure	Reset the fault and restart. Should the fault re-occur, contact the distributor near to you. For local contacts, go to: http://drives.danfoss.com/danfoss-drives/local-contacts/
6	Emergency stop	Stop signal has been given from the option board.	Check the emergency stop circuit.
7	Saturation trip	Various causes: component failure brake resistor short-circuit or overload	Cannot be reset from the keypad. Switch off power. DO NOT RE-CONNECT POWER! Contact factory. If this fault appears simultaneously with Fault 1, check motor cables and motor

Fault code	Fault	Possible cause	Correcting measures
8	System fault S7 = Charging switch S8 = No power to driver card S9 = Power unit communication (TX) S10 = Power unit communication (Trip) S11 = Power unit comm. (Measurement)	component failure faulty operation Note the exceptional Fault data record. See 7.3.4.3.	Reset the fault and restart. Should the fault re-occur, contact the distributor near to you. For local contacts, go to: http://drives.danfoss.com/danfoss-drives/local-contacts/
9	Undervoltage S1 = DClk too low during run S2 = No data from power unit S3 = Undervoltage control supervision	DC-link voltage is under the voltage limits defined in most probable cause: too low a supply voltage inverter internal fault a defective input fuse the external charge switch is not closed	In case of temporary supply voltage break, reset the fault and restart the inverter. Check the supply voltage. If it is adequate, an internal failure has occurred. Contact the nearest distributor. For local contacts, go to:
10	Input line supervision	The input line phase is missing.	Check the supply voltage, the fuses and supply cable.
11	Output phase supervision	Current measurement has detected that there is no current in one motor phase.	Check motor cable and motor.
12	Brake chopper supervision	No brake resistor installed brake resistor is broken brake chopper failure	Check brake resistor. If the resistor is ok, the chopper is faulty. Contact the distributor near to you. For local contacts, go to: http://drives.danfoss.com/danfoss-drives/local-contacts/
13	Inverter undertemperature	Heatsink temperature is under -10°C	
14	Inverter overtemperature	Heatsink temperature is over 90°C or 77°C (NX_6, FR6). Overtemperature warning is issued when the heatsink temperature exceeds 85°C (72°C).	Check the correct amount and flow of cooling air. Check the heatsink for dust. Check the ambient temperature. Make sure that the switching frequency is not too high in relation to ambient temperature and motor load.
15	Motor stalled	Motor stall protection has tripped.	Check motor.

Fault code	Fault	Possible cause	Correcting measures
16	Motor over-temperature	Motor overheating has been detected by inverter motor temperature model. Motor is overloaded.	Decrease the motor load. If no motor overload exists, check the temperature model parameters.
17	Motor underload	Motor underload protection has tripped.	Check the load.
18	Unbalance S1 = Current unbalance S2 = DC voltage unbalance	Unbalance between power modules in paralleled power units.	Should the fault re-occur, contact the distributor near to you. For local contacts, go to: http://drives.danfoss.com/danfoss-drives/local-contacts/
22	EEPROM checksum fault	Parameter save fault faulty operation component failure	Should the fault re-occur, contact the distributor near to you. For local contacts, go to: http://drives.danfoss.com/danfoss-drives/local-contacts/
24	Counter fault	Values displayed on counters are incorrect	
25	Microprocessor watchdog fault	faulty operation component failure	Reset the fault and restart. Should the fault re-occur, contact the distributor near to you. For local contacts, go to: http://drives.danfoss.com/danfoss-drives/local-contacts/
26	Start-up prevented	Start-up of the drive has been prevented. Run request in ON when new application is downloaded to the drive.	Cancel prevention of start-up. Remove Run request.
29	Thermistor fault	The thermistor input of option board has detected increase of the motor temperature	Check motor cooling and loading Check thermistor connection (If thermistor input of the option board is not in use it has to be short circuited)
30	Safe Torque Off	The input on OPTAF board has opened.	Cancel Safe Torque Off if this can be done safely.
31	IGBT temperature (hardware)	IGBT Inverter Bridge overtemperature protection has detected too high a short term overload current	Check loading. Check motor size.
32	Fan cooling	Cooling fan of the inverter does not start, when ON command is given.	Contact the nearest distributor. For local contacts, go to: http://drives.danfoss.com/danfoss-drives/local-contacts/
34	CAN bus communication	Sent message not acknowledged.	Ensure that there is another device on the bus with the same configuration.

Fault code	Fault	Possible cause	Correcting measures
35	Application	Problem in application software.	Contact the nearest distributor. For local contacts, go to: http://drives.danfoss.com/danfoss-drives/local-contacts/ If you are an application programmer, check the application program.
36	Control unit	Software function requires newer control board.	Change control unit
37	Device changed (same type)	Option board or control unit changed. Same type of board or same power rating of drive. The parameters are available in the drive.	Reset. The device is ready for use. The drive starts to use the old parameter settings. Note: No fault time data record!
38	Device added (same type)	Option board or drive added. Drive of same power rating or same type of board added. The parameters are available in the drive.	Reset The device is ready for use. The drive starts to use the old parameter settings. Note: No fault time data record!
39	Device removed	Option board removed. Drive removed.	The device is not available. Reset Note: No fault time data record!
40	Device unknown S1 = Unknown device S2 = Power1 not same type as Power2	Unknown option board or drive.	Contact the nearest distributor. For local contacts, go to: http://drives.danfoss.com/danfoss-drives/local-contacts/
41	IGBT temperature	IGBT Inverter Bridge overtemperature protection has detected too high a short term overload current	Check loading. Check motor size. Make an identification run.
42	Internal brake resistor overtemperature	Internal brake resistor overtemperature protection has detected too heavy braking	Set the deceleration time longer. Use external brake resistor.
43	Encoder fault 1 = Encoder 1 channel A is missing 2 = Encoder 1 channel B is missing 3 = Both encoder 1 channels are missing 4 = Encoder reversed 5 = Encoder board missing	Note the exceptional Fault data record. See 7.3.4.3. Additional codes: 1 = Encoder 1 channel A is missing 2 = Encoder 1 channel B is missing 3 = Both encoder 1 channels are missing 4 = Encoder reversed	Check encoder channel connections. Check the encoder board. Check the encoder frequency in the open loop.

Fault code	Fault	Possible cause	Correcting measures
44	Device changed (different type)	Option board or control unit changed. Option board of different type or different power rating of drive.	Reset Set the option board parameters again if option board was changed. Note: No fault time data record! Note: Application parameter values restored to default.
45	Device added (different type)	Option board or drive added. Option board of different type or drive of different power rating added.	Reset Set the power unit parameters again. Note: No fault time data record! Note: Application parameter values restored to default.
49	Division by zero in application	Division by zero has occurred in application program.	Should the fault re-occur while the AC drive is in run state, contact the distributor near to you. For local contacts, go to: http://drives.danfoss.com/danfoss-drives/local-contacts/ If you are an application programmer, check the application program.
50	Analogue input (sel. signal range 4 to 20 mA)	Current at the analogue input is < 4mA. control cable is broken or loose signal source has failed	Check the current loop circuitry.
51	External fault	Digital input fault.	Remove fault situation on external device.
52	Keypad communication fault	There is no connection between the control keypad and the inverter.	Check keypad connection and possible keypad cable.
53	Fieldbus fault	The data connection between the fieldbus Master and the fieldbus board is broken	Check installation. If installation is correct contact the nearest distributor. For local contacts, go to: http://drives.danfoss.com/danfoss-drives/local-contacts/
54	Slot fault	Defective option board or slot	Check board and slot. Contact the nearest distributor. For local contacts, go to: http://drives.danfoss.com/danfoss-drives/local-contacts/
56	PT100 board temp. fault	Temperature limit values set for the PT100 board parameters have been exceeded	Find the cause of temperature rise
57	Identification	Identification run has failed	Run command was removed before completion of identification run. The motor is not connected to the AC drive. There is load on motor shaft.

Fault code	Fault	Possible cause	Correcting measures
58	Brake	Actual status of the brake is different from the control signal.	Check the mechanical brake state and connections.
59	Follower communication	SystemBus or CAN communication is broken between Master and Follower.	Check the option board parameters. Check the optical fibre cable or CAN cable.
60	Cooling	Coolant circulation on liquid-cooled drive has failed.	Check the reason for the failure on the external system.
61	Speed error	Motor speed is unequal to reference.	Check of the encoder connection. PMS motor has exceeded the pull out torque.
62	Run disable	Run enable signal is low.	Check of the reason for the Run enable signal.
63	Quick stop	Command for quick stop received from digital input or fieldbus.	New run command is accepted after reset.
64	Input switch open	Drive input switch is open.	Check the main power switch of the drive.
65	Over Temp.	Temperature exceeded set limit. Sensor disconnected. Short circuit.	Find the cause of temperature rise.
70	Active filter fault	Fault triggered by dig. input (see param. P2.2.7.33). Remove fault situation on active filter	
74	Follower fault	When using normal Master Follower function this fault code is given if one or more follower drives trip to fault.	

Table 9-1. Fault codes

VACON[®]

www.danfoss.com

Vacon Ltd
Member of the Danfoss Group
Runsorintie 7
65380 Vaasa
Finland

Document ID:



DPD00908C

Rev. C

Sales code: DOC-USERFI4FI8+DLUK