

NX
AC DRIVES

DC FAN RETROFIT KIT INSTALLATION INSTRUCTIONS

TABLE OF CONTENTS

Document ID: DPD01124

Revision: V002

Revision release date: 21.01.2013

1. Introduction	1
1.1 Reason for the fan change.....	1
1.2 Compatibility.....	1
1.3 Safety notes.....	2
2. FR8 retrofit kit installation	3
2.1 Retrofit kit contents.....	3
2.2 Removing the AC fan and fan inverter.....	4
2.3 DC fan and DC power supply installation.....	9
3. FI9, NFE G2 and NFE G1 retrofit kit installation	11
3.1 Retrofit kit contents.....	11
3.2 Removing the AC fan and fan inverter.....	13
3.2.1 Instructions for FI9.....	13
3.2.2 Instructions for NFE G2.....	19
3.2.3 Instructions for NFE G1.....	21
3.3 DC fan and DC power supply installation.....	22
3.3.1 Instructions for FI9.....	22
3.3.2 Instructions for NFE G2.....	24
3.3.3 Instructions for NFE G1.....	25
4. FR9 retrofit kit installation	28
4.1 Retrofit kit contents.....	28
4.2 Removing the AC fan and fan inverter.....	29
4.3 DC fan and DC power supply installation.....	33
5. FI10 and FI12 retrofit kit installation	35
5.1 Retrofit kit contents.....	35
5.2 Removing the AC fan and fan inverter.....	36
5.3 DC fan and DC power supply installation.....	38
6. FR10 and FR12 retrofit kit installation	39
6.1 Retrofit kit contents.....	39
6.2 Removing the AC fan and fan inverter.....	40
6.3 DC fan and DC power supply installation.....	42
7. FR11 retrofit kit installation	43
7.1 Retrofit kit contents.....	43
7.2 Removing the AC fan and fan inverter.....	44
7.3 DC fan and DC power supply installation.....	47
8. FI13-14 and FR13-14 retrofit kit installation	48
8.1 Retrofit kit contents.....	48
8.2 Removing the AC fan and fan inverter.....	52
8.2.1 Instructions for FI13 and FI14.....	52
8.2.2 Instructions for FR13 and FR14.....	55
8.3 DC fan and DC power supply installation.....	56
8.3.1 Instructions for FI13 and FI14.....	56
8.3.2 Instructions for FR13 and FR14.....	57
9. Testing the DC fan and power supply	58

1. INTRODUCTION

This document introduces new fan cooling systems to existing NX drives in the range of FR8-14. The AC main fans will be updated to DC fan cooling systems. The efficiency of the fans is stated in the European Union directive (ErP) which all products now fulfill.

1.1 REASON FOR THE FAN CHANGE

The aim of the ErP Directive (Energy related Products Directive) is to protect the environment by increasing the total share of renewable energy in the EU to 20% by 2020 and by increasing energy efficiency by 20%. The ErP implementation measure for fans defines the minimum efficiency for fans in the 125W to 500kW power range.

The ErP Directive is being implemented in 2 steps: in 2013 Step 1, and in 2015 Step 2 become effective. The minimum efficiency requirement placed on the system efficiency is the prerequisite for a CE mark and is thus mandatory for utilisation in EU member states.

The directive does not require replacement of systems put into operation before the ErP start date. There is a period of transition for replacement fans, meaning, non-compliant fans may be installed as retrofits up to 31.12.2014. Starting from 01.01.2015 however, these also have to comply with the ErP requirements.

The ErP Directive is limited to the EU member states. However, importers in these countries are also required to meet the requirements.

All new drives with AC main fans which are affected by the ErP directive will be changed to DC fan cooling systems by the end of year 2012. Current AC fan spare part kits have been replaced by fully compatible DC fan kits. AC fan kits will still be available for a limited time but no longer than 2014.

1.2 COMPATIBILITY

The DC fan retrofit kits are available for NX drives in the range of FR8-FR14. Kits for inverter and NFE units in this range are also available. See Table 1.1 on page 2 for a complete list of available DC fan retrofit kits and their corresponding spare part numbers.

Retrofitting a DC fan supply system requires replacing the AC fan and fan inverter with a DC fan and DC power supply. Both the DC fan and DC power supply must be installed at the same time, neither of them is compatible with the AC fan or fan inverter. Do not install DC and AC fans in the same drive!

Table 1.1. DC fan retrofit kits

Spare part number	Retrofit kit
60S00965	DC fan retrofit assembly kit for FR8, 500/690V
60S01053	DC fan retrofit assembly kit for FR8, 230V
60S00966	DC fan retrofit assembly kit for FR9, 500/690V
60S01054	DC fan retrofit assembly kit for FR9, 230V
60S00967	DC fan retrofit assembly kit for FR10
60S00971	DC fan retrofit assembly kit for FR11
60S00970	DC fan retrofit assembly kit for FR12
60S00979	DC fan retrofit assembly kit for FR13 (FI13+2xNFE)
60S00980	DC fan retrofit assembly kit for FR13 (FI13+3xNFE)
60S00981	DC fan retrofit assembly kit for FR13 (FI13+4xNFE)
60S00982	DC fan retrofit assembly kit for FR14 (FI14+3xNFE)
60S00983	DC fan retrofit assembly kit for FR14 (FI14+4xNFE)
60S00976	DC fan retrofit assembly kit for NFE
60S00968	DC fan retrofit assembly kit for FI9/NFE G2
60S00969	DC fan retrofit assembly kit for FI10
60S00972	DC fan retrofit assembly kit for FI12
60S00973	DC fan retrofit assembly kit for FI13
60S00974	DC fan retrofit assembly kit for FI14

1.3 SAFETY NOTES



Only qualified trained service personnel are allowed to use this material and perform any of the service actions mentioned. The personnel performing local service work on the drives must have qualifications that are in accordance with their national laws.



After disconnecting the AC drive from the mains, **wait** until the fan stops and the indicators on the keypad go out (if no keypad is attached see the indicators on the cover). Wait 5 more minutes before doing any work on the connections of drive. Do not open the cover before this time has expired. After expiration of this time, use measuring equipment to absolutely ensure that no voltage is present. **Always ensure the absence of voltage before starting any electrical work!**



Make sure that the AC drive is not connected to mains while the cover is open and the drive is being worked on.



Remember to use ESD protection at all times when working with electronic components of the AC drive.

2. FR8 RETROFIT KIT INSTALLATION

2.1 RETROFIT KIT CONTENTS

Table 2.1. FR8 DC fan retrofit assembly kit for 500/690V and 230V drives (spare part numbers: 60S00965 and 60S01053)

#	Item number	Item description	Pcs
1	70CPA00550	FR8 Maintenance DC fan assembly	1
2	70CPA00549	DC fan supply assembly, 48V, 105W (in 500/690V kit)	1
	70CPA00859	DC fan supply assembly, 48V, 105W (in 230V kit)	
3	70CMC00407	M4x6-DIN7500CE-Thread Forming-Zn-Tx screw	4
4	MC00109	M6-DIN985-8-Zn-Nylock nut	2
5	MC00068	2.4x112 cable tie	10
6	70CPL00062	'Product modified'-sticker	1

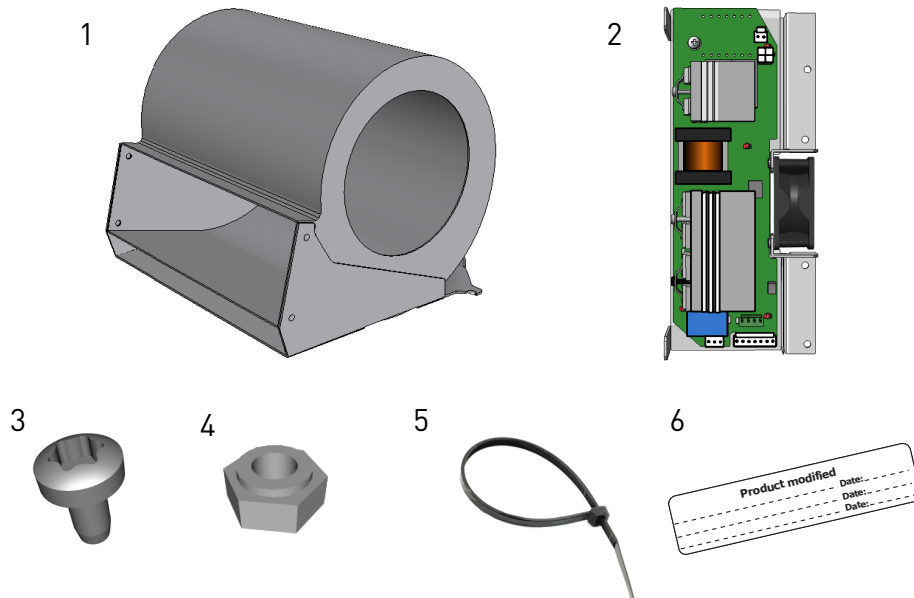

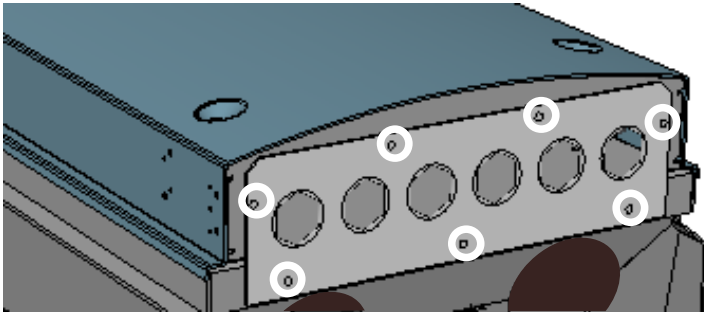

Figure 2.1. FR8 DC fan retrofit assembly kit for 500/690V and 230V drives (spare part numbers: 60S00965 and 60S01053)

2.2 REMOVING THE AC FAN AND FAN INVERTER

Before installing the new DC fan and DC power supply, remove the old AC fan and fan inverter.

Parts to remove:

- AC fan
- Fan inverter and fan capacitor assembly
- Isolation transformer

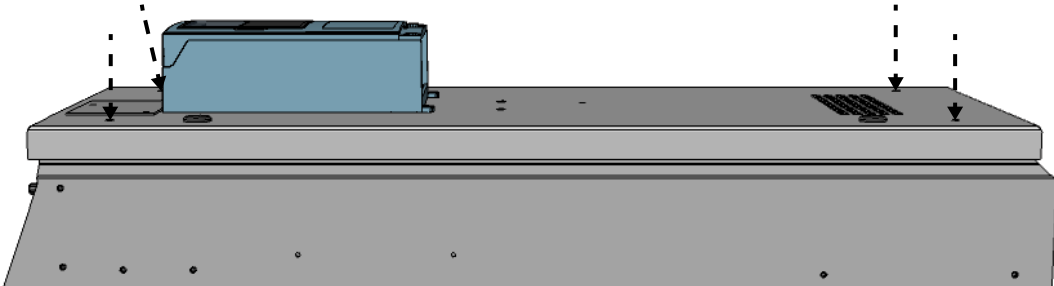
1	<p>Release the conduit plate from the main cover. Remove the seven M4x8 mounting screws. Use bit Pz2 and torque 2.4Nm.</p>  <p><i>Figure 2.2. Removing the conduit plate</i></p>
2	<p>Take off the drive main cover. Remove the four M4x60 mounting screws. Use bit Pz2 and torque 0.8Nm.</p>  <p><i>Figure 2.3. Releasing the main cover</i></p>
3	<p>Open the power unit cover. Remove the four M4x16 mounting screws. Use bit Pz2 and torque 0.82Nm.</p>  <p><i>Figure 2.4. Power unit cover mounting screws</i></p>

4

To access the fan inverter and fan capacitor, the main terminal assembly needs to be removed.

First release the input cables and motor output busbars from the main terminal connectors. Remove the six M8 nuts. Use a 13mm bit and torque 20Nm.

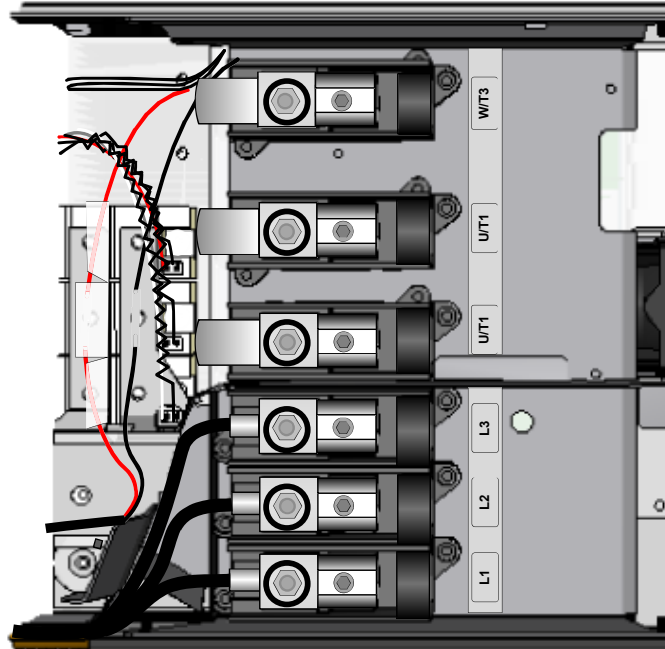

Figure 2.5. Main terminal mounting nuts

5

Release the main terminal assembly. Loosen the five M4 nylock nuts with a 7mm bit and torque 1.35Nm, and the M4x8 screw with bit Pz2 and torque 2.4Nm.

Lift off the main terminal assembly.

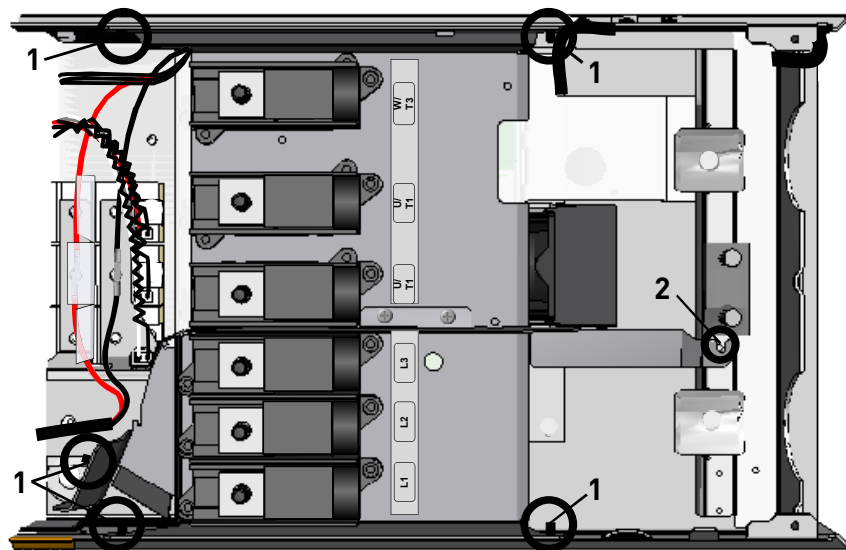

Figure 2.6. Releasing the main terminal assembly: M4 nuts (1) and M4x8 screw (2)

6

Disconnect:

1. brown and blue capacitor wires from the insulation transformer connector,
2. black, brown and blue fan wires from the insulation transformer connector,
3. blue and black insulation transformer wires from the fan inverter,
4. yellow/green fan grounding wire from the frame, use bit Pz2 and torque 2.4Nm to remove the screw.

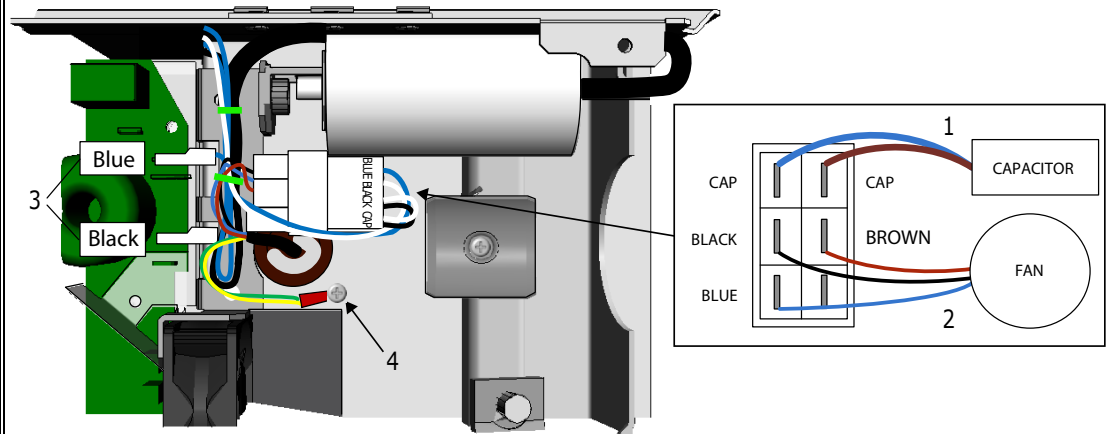

Figure 2.7. Fan and fan inverter wiring

7

1. Disconnect the DC supply wire from fan inverter connector X2,
2. Disconnect the fan control wire from fan inverter connector X8,
3. Disconnect the internal fan supply wire from the internal fan,
4. Cut off the cable tie holding the internal fan supply wire.

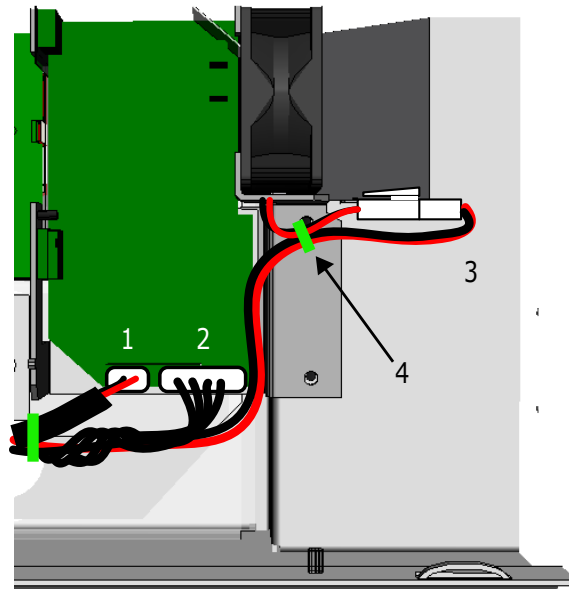

Figure 2.8. Fan inverter and internal fan wiring

8

Remove the four M4x6 fan inverter assembly mounting screws. Use bit Pz2 and torque 2.4Nm.

Take off the fan inverter and fan capacitor assembly.

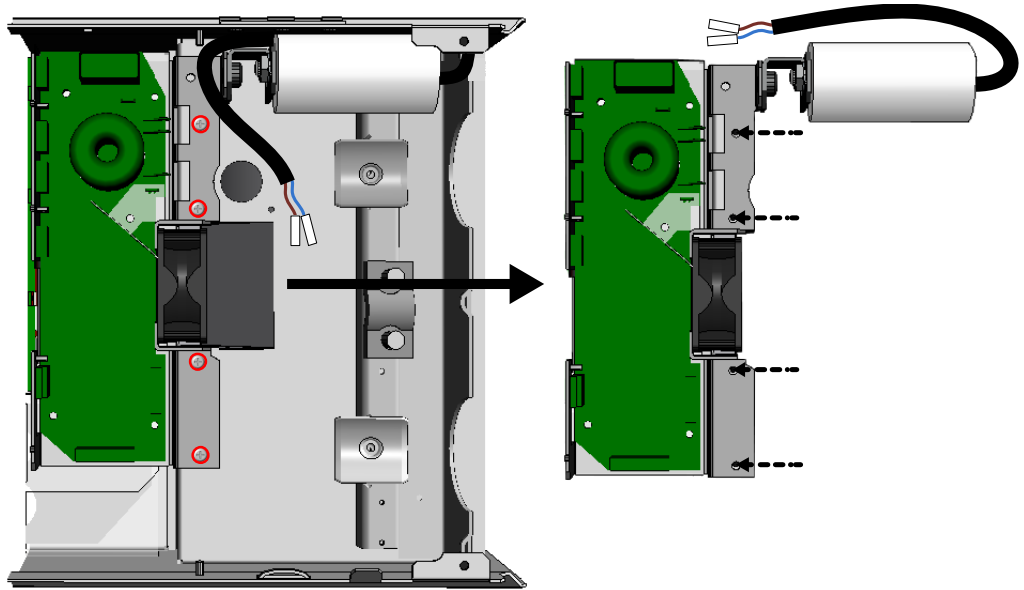

Figure 2.9. Removing the fan inverter assembly

9

Remove the cable ties holding the isolation transformer wires to the power-control cable.

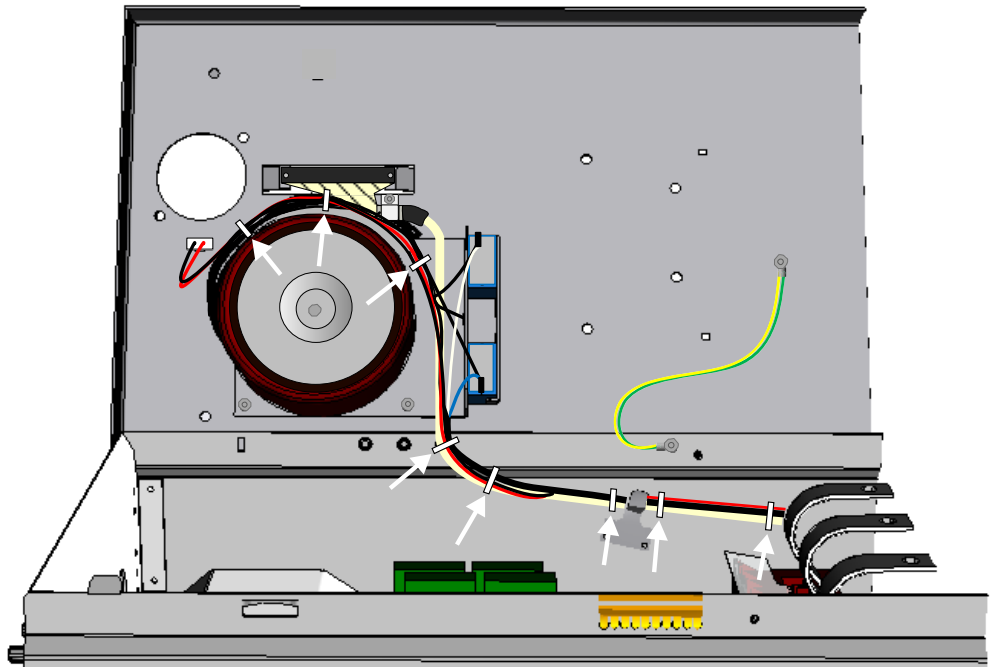

Figure 2.10. Cable ties holding the isolation transformer wires

10

Remove the four M4 nylock nuts. Use a 7mm bit and torque 1.4Nm.
Take off the isolation transformer assembly and wires.

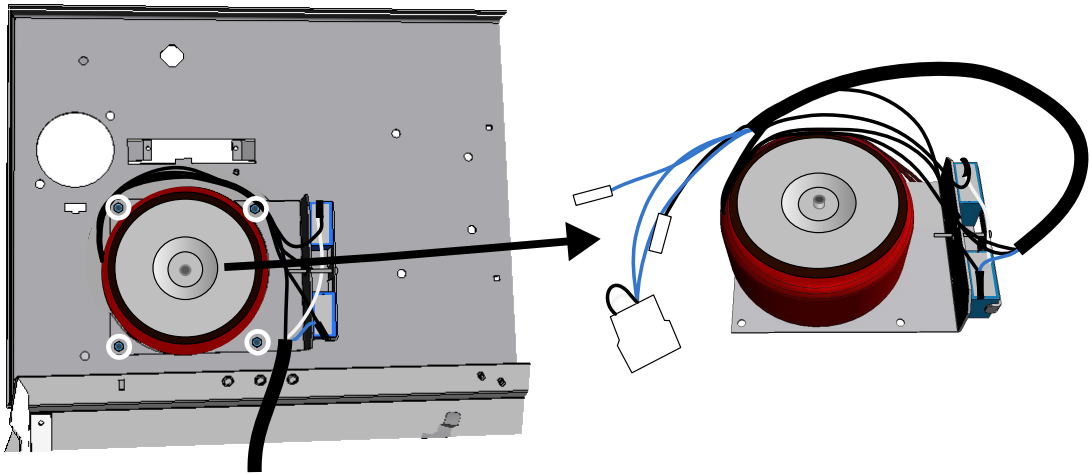

Figure 2.11. Removing the isolation transformer

11

Remove the AC fan. Release the two M6 nuts with a 10mm bit.
Pull out the fan assembly. **NOTE!** Also take out the fan supply cable and grommet.

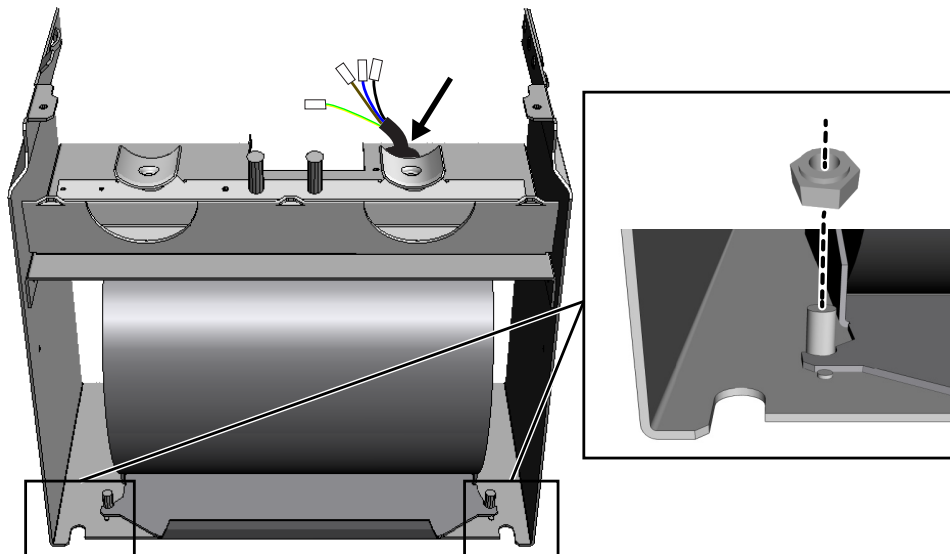

Figure 2.12. Removing the AC fan

2.3 DC FAN AND DC POWER SUPPLY INSTALLATION

Once the AC fan and other old parts have been removed (see Chapter 2.2), install the new DC fan and DC power supply.

1	<p>Install the DC fan. The fan is mounted in the same way as the old AC fan (see Figure 2.12 on page 8). Use the two M6 nylock nuts (MC00109) supplied in the retrofit kit.</p> <p>NOTE! Lead in the fan supply cable before mounting the fan and close the hole with the grommet.</p>
2	<p>Install the DC power supply. Use the four M4x6 screws (MC00043) supplied in the retrofit kit. Use bit Pz2 and torque 2.4Nm.</p> <p>Connect the fan power supply wire on fan power supply connector X81.</p> 
3	<ol style="list-style-type: none"> 1. Connect the DC supply wire to power supply connector X2, 2. Connect the fan control wire to power supply connector X8, 3. Connect the internal fan supply wire to the internal fan, 4. Place a cable tie (MC00068, supplied in the retrofit kit) on the internal fan supply wire. <p>See Figure 2.8 on page 6.</p>
4	<p>Check that the power supply and DC fan function. See the testing instructions in Chapter 9.</p> <p>If the fan and power supply work properly, re-assemble the drive. See the instructions below.</p>

Figure 2.13. Installing the fan power supply

5

Use the cable ties (MC00068) supplied in the retrofit kit to tie together the internal fan wire and control-power cable.

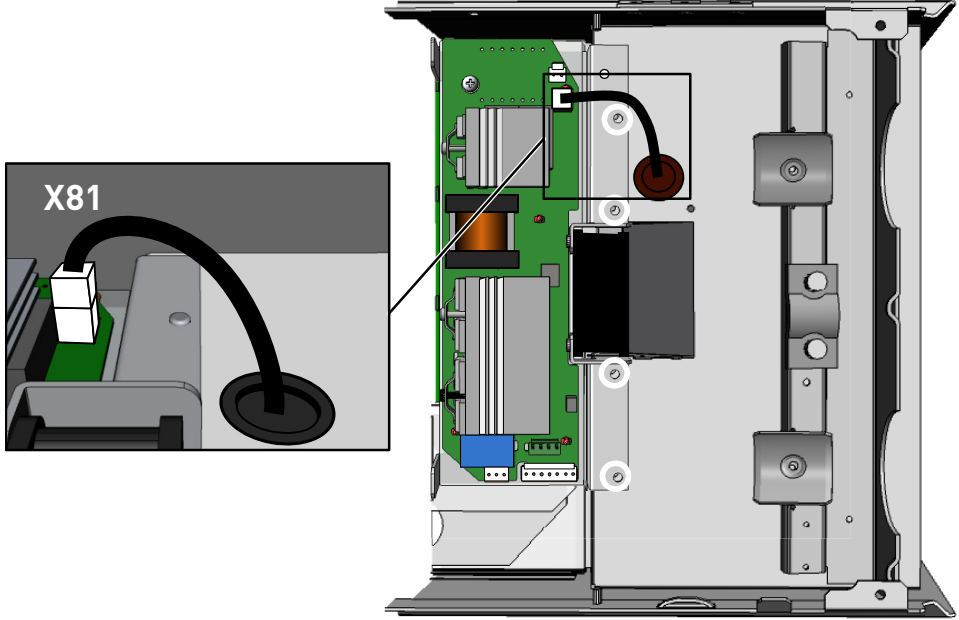
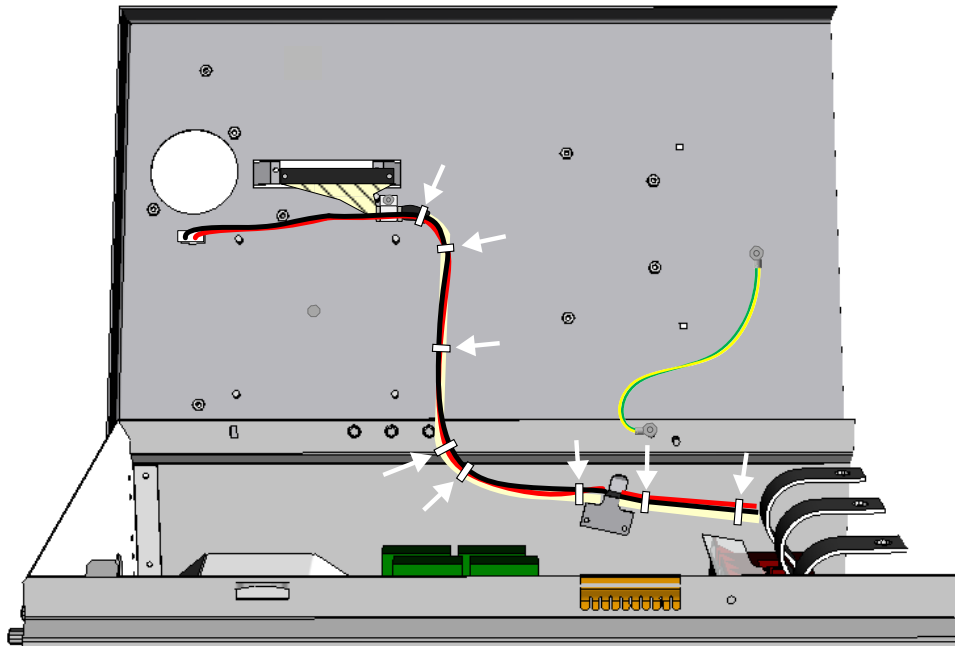

Figure 2.14. Control-power cable and internal fan wire routing

6

Re-attach the main terminal assembly. See the instructions in Step 5 on page 5.

7

Re-connect the input cables and motor output busbars on the main terminal connectors. See the instructions in Step 4 on page 5.

8

Close the power unit cover. See the instructions in Step 3 on page 4.

9

Re-attach the main cover. See the instructions in Step 2 on page 4.

10

Re-attach the conduit plate. See the instructions in Step 1 on page 4.

11

Attach the 'Product modified'-sticker (70CPL00062) supplied in the retrofit kit in a visible place on the front side of the drive. On the sticker, write "DC fan retrofit" and the installation date.

3. FI9, NFE G2 AND NFE G1 RETROFIT KIT INSTALLATION

NFE G1 units are only used in FR13 and FR14 drives, whereas NFE G2 units can be installed individually. The NFE G2 unit is also visually different from NFE G1, as NFE G2 has an API control panel on the front cover.

3.1 RETROFIT KIT CONTENTS

Table 3.1. FI9/NFE G2 DC fan retrofit assembly kit (spare part number: 60S00968)

#	Item number	Item description	Pcs
1	70CPA00556	FI9 Maintenance DC fan assembly	1
2	70CMC03903	DC/DC fan supply assembly, 48V full-bridge 240W	1
3	70CMR00188	48V _{DC} fan extension wire	1
4	MC00031	M4x8-DIN7500CE-Thread Forming-Zn-Pz	3
5	MC00046	M5x10-DIN7500CE-Thread Forming-Zn-Pz	4
6	MC00178	3.6x205 white/black cable tie	4
7	MC00705	Holder TA1S8 M4	1
8	70CPL00062	'Product modified'-sticker	1

Table 3.2. NFE G1 DC fan retrofit assembly kit (spare part number: 60S00976)

#	Item number	Item description	Pcs
1	70CPA00556	FI9 Maintenance DC fan assembly	1
2	70CMC03903	DC/DC fan supply assembly, 48V full-bridge 240W	1
3	70CMR00188	48V _{DC} fan extension wire	1
4	MC00031	M4x8-DIN7500CE-Thread Forming-Zn-Pz	2
5	MC00046	M5x10-DIN7500CE-Thread Forming-Zn-Pz	4
6	MC00178	3.6x205 white/black cable tie	6
7	MC00705	Holder TA1S8 M4	1
8	70CPL00062	'Product modified'-sticker	1
9	70CPE05112	DC- additional wire kit	1

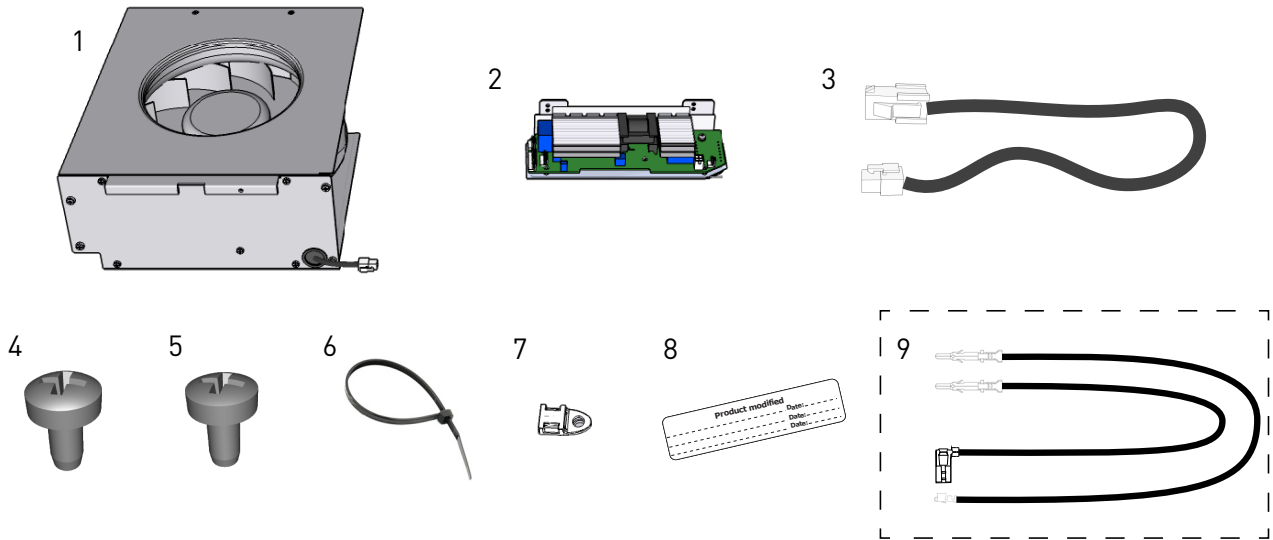

Figure 3.1. FI9, NFE G2 and NFE G1 DC fan retrofit assembly kits (spare part numbers: 60S00968 and 60S00976). Part 9 is included only in kit 60S00976.

3.2 REMOVING THE AC FAN AND FAN INVERTER

Before installing the new DC fan and DC power supply, remove the old AC fan and fan inverter. Parts to remove:

- AC fan
- Fan inverter
- Fan capacitor and bracket
- Isolation transformer
- Fan extension cable

3.2.1 INSTRUCTIONS FOR FI9

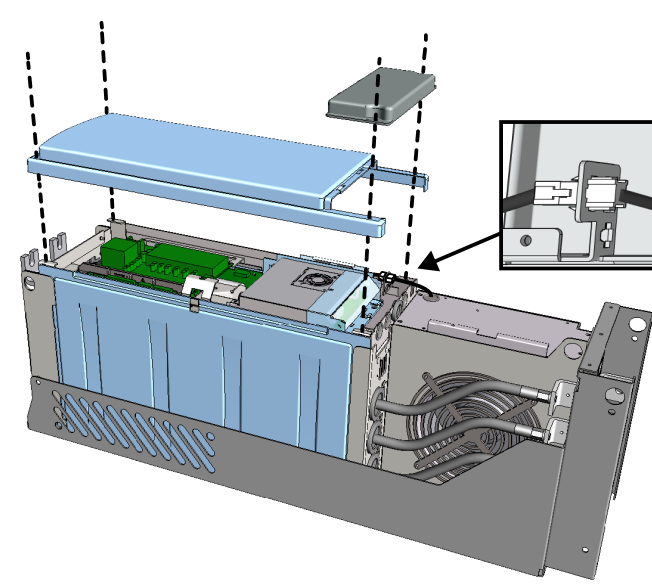
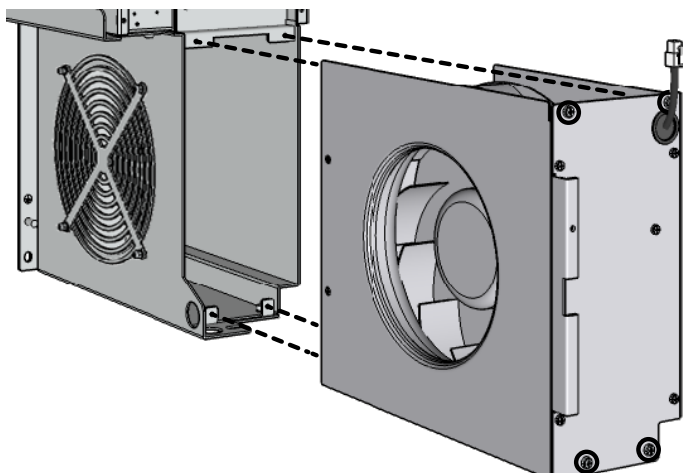
1	<p>Remove the connection and front covers. Release the four M5x16 mounting screws. Use bit Pz2 and torque 2Nm.</p> <p>Also disconnect the fan supply cable.</p>  <p><i>Figure 3.2. Removing the covers and disconnecting the fan supply cable</i></p>
2	<p>Release the AC fan. Remove the four M5x10 mounting screws with bit Pz2 and torque 3.5Nm and pull out the fan.</p>  <p><i>Figure 3.3. Removing the main fan</i></p>

3

Remove the ASIC assembly covers. Release it by removing the M4x8 combi screws. Use bitTx20 and torque 1.1Nm.

NOTE! Notice the earthing wire under one of the cover mounting screws (marked with arrow in the figure below).

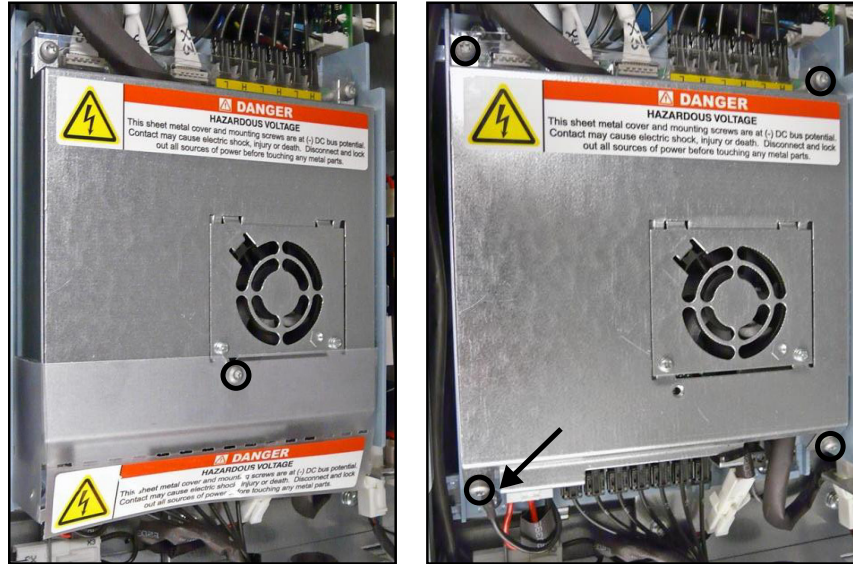

Figure 3.4. Removing the ASIC assembly covers

4

Remove the cable connector press from on top of the current measurement wires and driver-ASIC optical fibers.

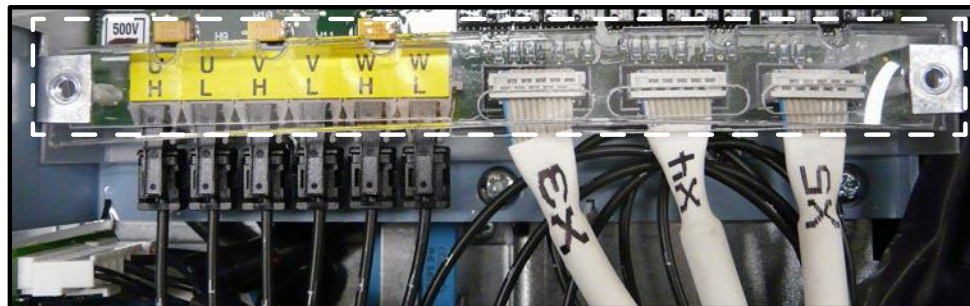

Figure 3.5. Cable connector press

Disconnect all wires from the asic board:

- control optical fibers (1-7)
- driver optical fibers (UH, UL, VH, VL, WH, WL)
- control 24V_{DC} supply cable, connector X10
- asic internal fan wire, connector X1
- asic wire set, connector X6
- fan control wire, connector X11
- testing cable, connector X2
- current measurement cables, connectors X3, X4 and X5

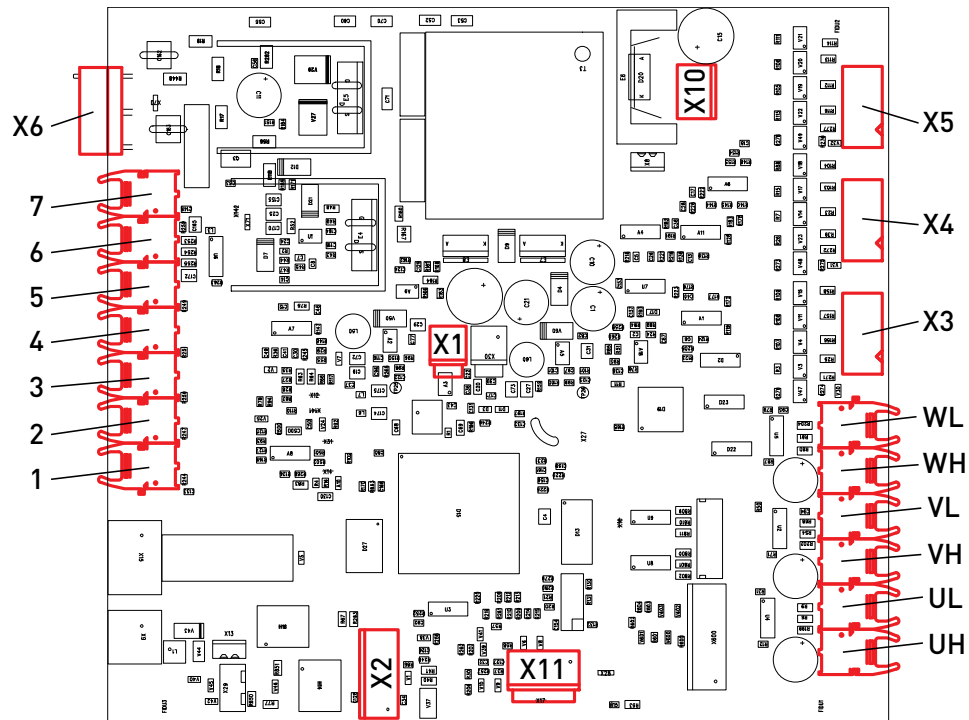

Figure 3.6. ASIC board connectors

Remove the asic assembly from the drive. Release the four M4x8 mounting screws. Use bit Pz2 and torque 3.5Nm.

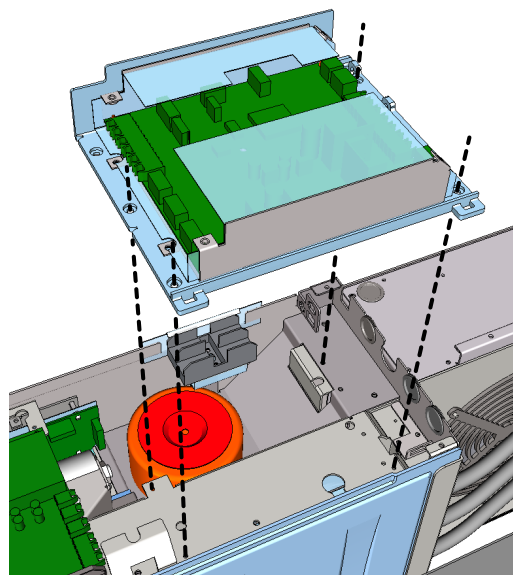

Figure 3.7. Removing the asic assembly

7

Disconnect all wires from the driver board:

- Optical fibers (UL, VL, WL, UH, VH, WH)
- Current measurement cable, connectors X13, X14, X15 and X32
- Measurement board flat cable, connectors X30 and X31
- Gate driver wire top transistor, connector X28
- Gate driver wire bottom transistor connector X29
- Driver power supply wires, connector X1

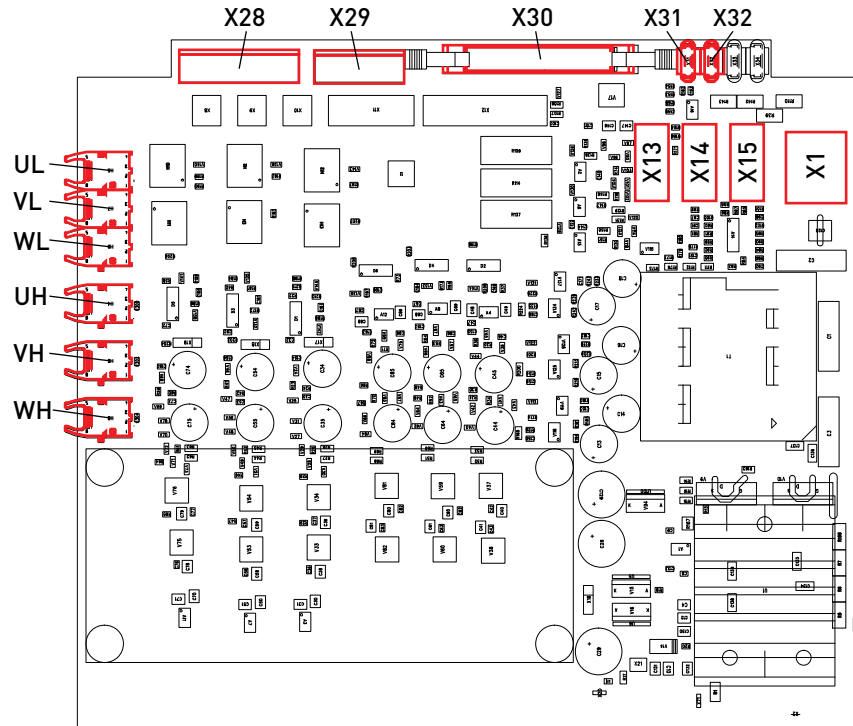

Figure 3.8. FI9 driver board connectors

8

Remove the four M4x12 mounting screws. Use bit Tx20 and torque 0.69Nm. Take off the connector holder and lift off the driver board.

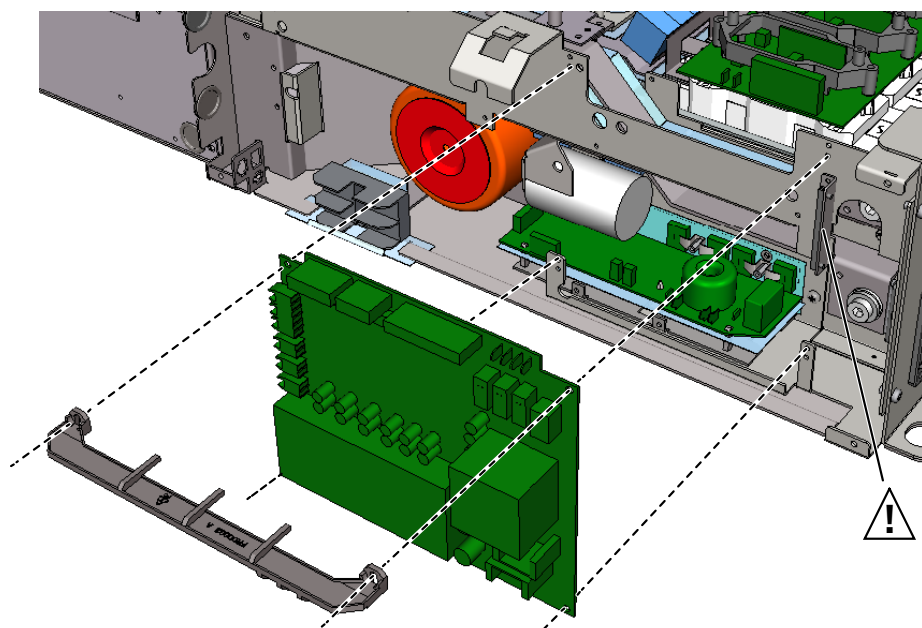

Figure 3.9. Driver board mounting. Notice the board holder.

9	<p>Disconnect all wires from the fan inverter:</p> <ul style="list-style-type: none"> • supply cable from connector X2 • fan inverter control cable from connector X8 • fan control FB wire from connector X3 • black and blue isolation transformer wires from connectors X4 and X7 <p style="text-align: center;"><i>Figure 3.10. Fan inverter connectors</i></p>
10	<p>Take out the fan inverter. Remove the two M4x8 mounting screws. Use bit Pz2 and torque 3.5Nm.</p> <p style="text-align: center;"><i>Figure 3.11. Removing the fan inverter</i></p>

11

Release the fan capacitor from the capacitor bracket. Remove the mounting nut with a 19mm bit and torque 5Nm.

Take off the capacitor bracket. Remove the M8x12 mounting screw. Use torque 20Nm.

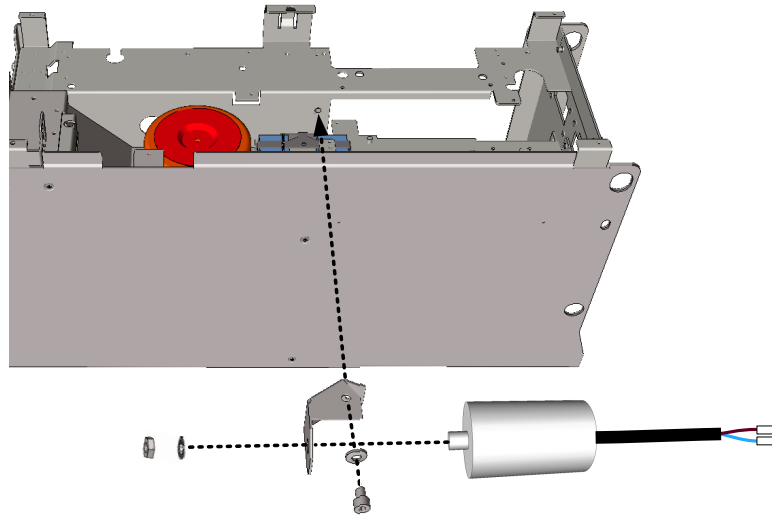

Figure 3.12. Removing the fan capacitor and bracket

12

Take out the isolation transformer capacitors. Remove the M4x8 grounding screw (1) and the M4x25 mounting screw (2). Use bit Pz2 and torque 1.1Nm for both screws.

Disconnect the isolation transformer wire from the fan extension wire and take off the isolation transformer. Remove the M8x70 mounting screw (3). Use bit HOP 6x100 and torque 10Nm.

Remove the fan extension wire (4).

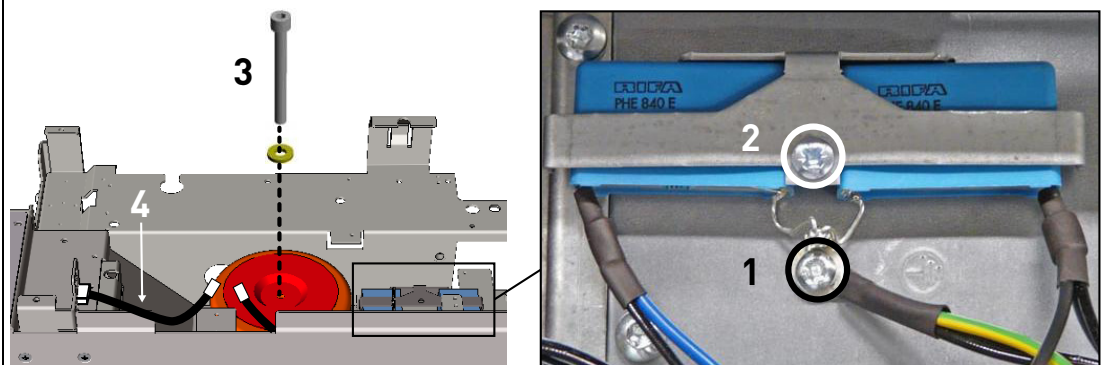
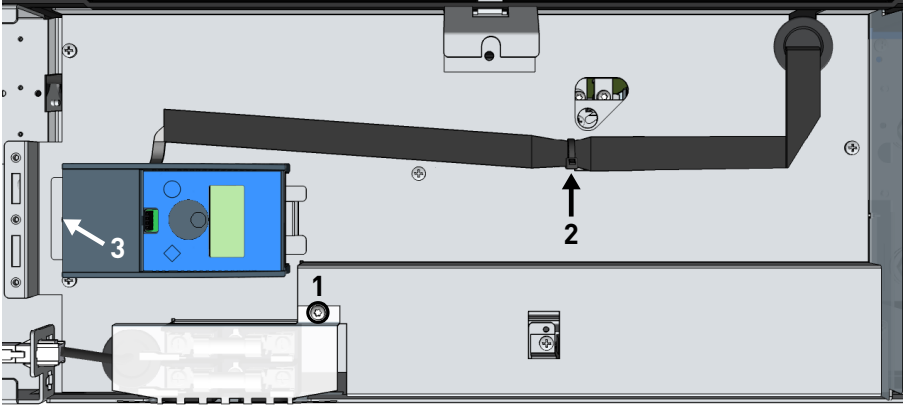
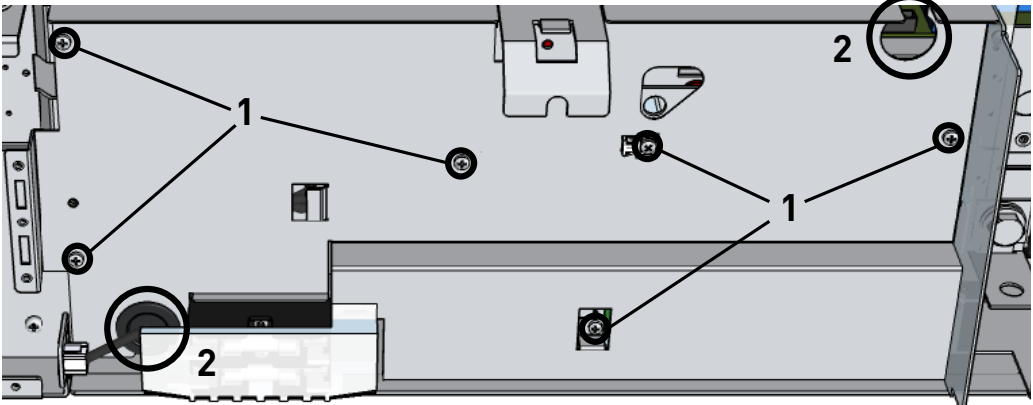
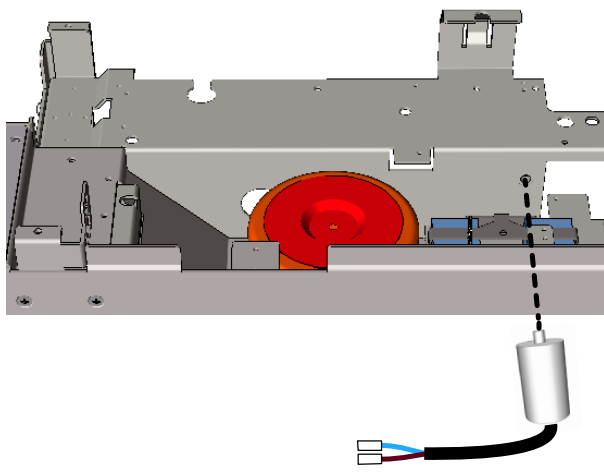

Figure 3.13. Removing the isolation transformer, capacitors and fan extension wire

3.2.2 INSTRUCTIONS FOR NFE G2

<p>1</p>	<p>Remove the connection and front covers and disconnect the fan supply cable. See Figure 3.2 on page 13.</p>
<p>2</p>	<p>Remove the AC fan. See Figure 3.3 on page 13.</p>
<p>3</p>	<p>1. Remove the M4x8 screw holding the fuse base insulator. Use bit Tx20 and torque 0.8Nm, 2. Cut the cable tie holding the API control flat cable, 3. Remove the M4x8 screw holding the API support. Use bit Pz2 and torque 3.5Nm.</p>  <p style="text-align: center;"><i>Figure 3.14. Remove two screws and a cable tie</i></p>
<p>4</p>	<p>Move the API control unit out of the way and remove the six M4x8 sheet cover mounting screws (1). Use bit Pz2 and torque 3.5Nm. When lifting off the cover, carefully release the grommets and cables from the cover lead-in holes (2).</p>  <p style="text-align: center;"><i>Figure 3.15. Removing the sheet cover</i></p>
<p>5</p>	<p>Disconnect all wires from the fan inverter. See Figure 3.10 on page 17. NOTE! Also take off the jumper from connector X3.</p>
<p>6</p>	<p>Take out the fan inverter. See Figure 3.11 on page 17.</p>

7	<p>Remove the fan capacitor.</p> <div style="text-align: center;">  </div> <p style="text-align: center;"><i>Figure 3.16. Removing the fan capacitor</i></p>
8	<p>Take out the isolation transformer, capacitors and fan extension wire. See Figure 3.13 on page 18.</p>

3.2.3 INSTRUCTIONS FOR NFE G1

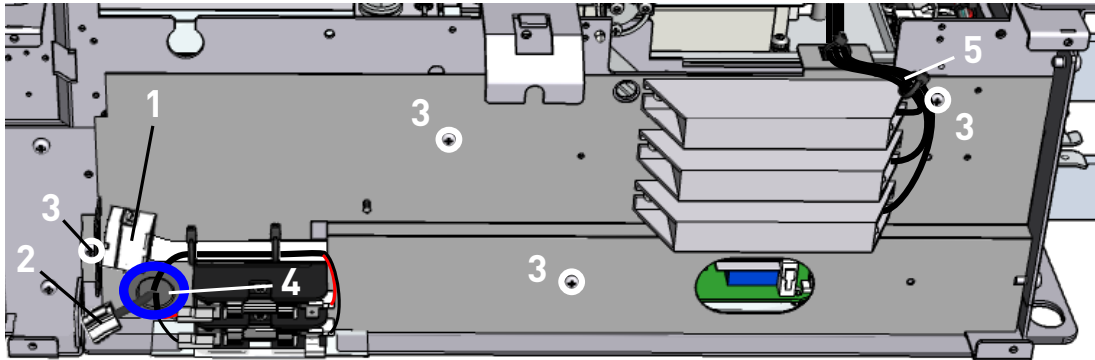
1	Remove the connection and front covers and disconnect the fan supply cable. See Figure 3.2 on page 13.
2	Remove the AC fan. See Figure 3.3 on page 13.
3	<p>To remove the sheet cover:</p> <ol style="list-style-type: none"> 1. Disconnect the NFE wire harness from the connector holder on the sheet cover, 2. Disconnect the fan extension wire from the connector holder on the sheet cover, 3. Remove the four M4x8 mounting screws. Use bit Pz2 and torque 3.5Nm, 4. Carefully release the grommet and cables from the cover lead-in hole, 5. Lift off the sheet cover. NOTE! Notice the charging resistor wires.  <p style="text-align: center;"><i>Figure 3.17. Removing the NFE sheet cover</i></p>
4	Disconnect all wires from the fan inverter. See Figure 3.10 on page 17.
5	Take out the fan inverter. See Figure 3.11 on page 17.
6	Remove the fan capacitor. See Figure 3.16 on page 20.
7	Take out the isolation transformer, capacitors and fan extension wire. See Figure 3.13 on page 18.

3.3 DC FAN AND DC POWER SUPPLY INSTALLATION

Once the AC fan and other old parts have been removed (see Chapter 3.2), install the new DC fan and DC power supply.

3.3.1 INSTRUCTIONS FOR FI9

1	Install the DC fan. The fan is mounted in the same way as the old AC fan (see Figure 3.3 on page 13). Use the four M5x10 mounting screws (MC00046) supplied in the retrofit kit.
2	<p>Install the DC power supply. Use the two M4x8 mounting screws (MC00031) supplied in the retrofit kit. Use bit Pz2 and torque 3.5Nm.</p> 

Figure 3.18. Installing the fan power supply

<p>3</p>	<p>Connect the following wires:</p> <ol style="list-style-type: none"> 1. fan power supply wire to connector X81 on the fan power supply, 2. DC supply wire to connector X2 on the fan power supply, 3. fan control wire to connector X8 on the fan power supply, 4. fan control FB wire to connector X3 on the fan power supply, 5. 48V_{DC} fan extension wire (70CMR00188) supplied in the retrofit kit to fan supply cable, 6. Use two of the cable ties (MC00178) supplied in the retrofit kit to tie together the excess 48V_{DC} fan extension wire and the FI9 wire harness.  <p style="text-align: center;"><i>Figure 3.19. Fan power supply wiring</i></p>
<p>4</p>	<p>Check that the power supply and DC fan function. See the testing instructions in Chapter 9.</p> <p>If the fan and power supply work properly, re-assemble the drive. See the instructions below.</p>
<p>5</p>	<p>Re-attach the parts (driver board, asic assembly, covers) and re-assemble the drive by following the instructions in Step 1 to Step 8 in Chapter 3.2.1 in reversed order.</p>
<p>6</p>	<p>Attach the 'Product modified'-sticker (70CPL00062) supplied in the retrofit kit in a visible place on the front side of the drive. On the sticker, write "DC fan retrofit" and the installation date.</p>

3.3.2 INSTRUCTIONS FOR NFE G2

1	Install the DC fan. The fan is mounted in the same way as the old AC fan (see Figure 3.3 on page 13). Use the four M5x10 mounting screws (MC00046) supplied in the retrofit kit.
2	Install the DC power supply. Use the two M4x8 mounting screws (MC00031) supplied in the retrofit kit. Use bit Pz2 and torque 3.5Nm. See Figure 3.18 on page 22.
3	<p>Connect the following wires:</p> <ol style="list-style-type: none"> 1. 48V_{DC} fan extension wire (70CMR00188) supplied in the retrofit kit to connector X81 on the fan power supply, 2. DC supply wire to connector X2 on the fan power supply, 3. fan control wire to connector X8 on the fan power supply, 4. jumper to connector X3 on the fan power supply, 5. 48V_{DC} fan extension wire to fan supply cable, 6. Use two of the cable ties (MC00178) supplied in the retrofit kit to tie together the excess 48V_{DC} fan extension wire.  <p style="text-align: center;"><i>Figure 3.20. Wire connections and routing</i></p>
4	<p>Check that the power supply and DC fan function. See the testing instructions in Chapter 9.</p> <p>If the fan and power supply work properly, re-assemble the drive. See the instructions below.</p>
5	Re-attach the sheet cover. See the instructions in Step 4 on page 19.
6	Re-attach the API control unit and fuse base insulator and route the control flat cable as shown in Step 3 on page 19.
7	Re-attach the covers. See the instructions in Step 1 on page 13.
8	Attach the 'Product modified'-sticker (70CPL00062) supplied in the retrofit kit in a visible place on the front side of the drive. On the sticker, write "DC fan retrofit" and the installation date.

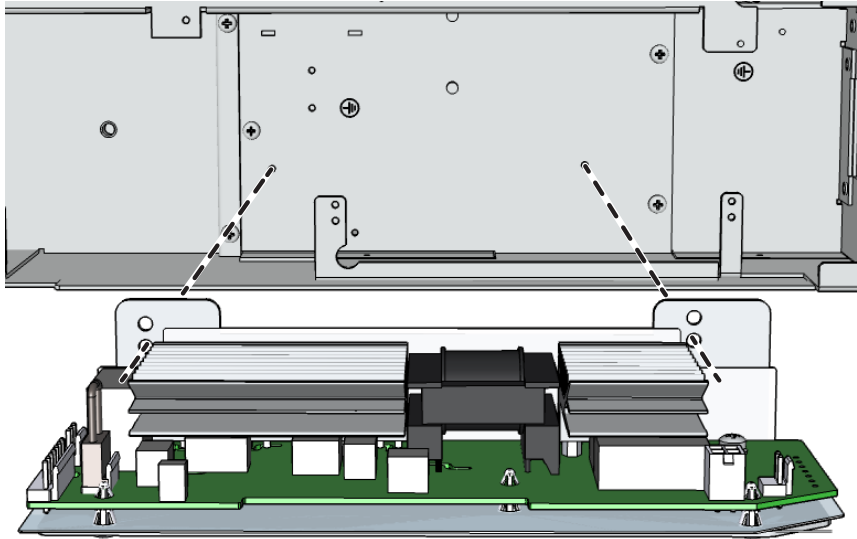
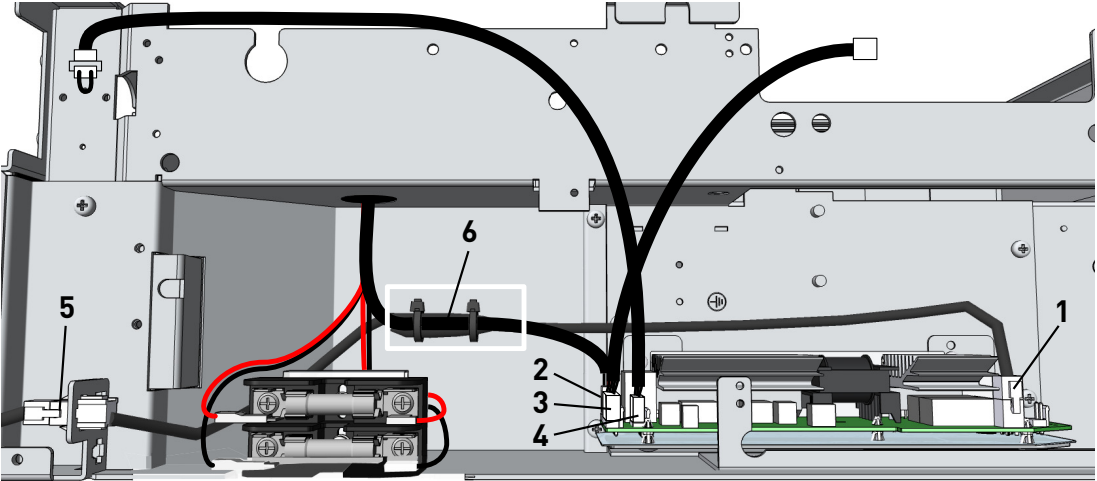
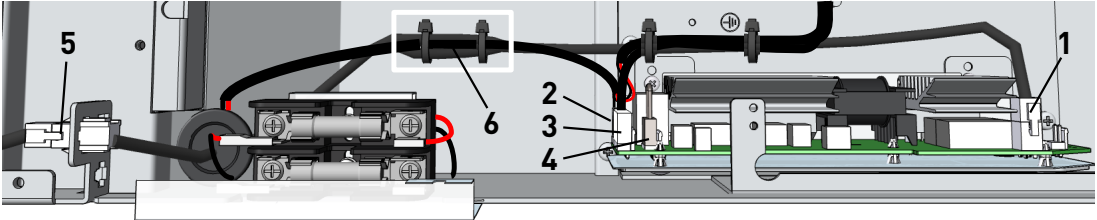
3.3.3 INSTRUCTIONS FOR NFE G1

1	Install the DC fan. The fan is mounted in the same way as the old AC fan (see Figure 3.3 on page 13). Use the four M5x10 mounting screws (MC00046) supplied in the retrofit kit.
2	Install the DC power supply. Use the two M4x8 mounting screws (MC00031) supplied in the retrofit kit. Use bit Pz2 and torque 3.5Nm. See Figure 3.18 on page 22.
3	<p>The NFE wire harness needs to be modified by adding the two DC- wires (70CPE05112) supplied in the retrofit kit:</p> <ol style="list-style-type: none"> 1. Connect the 300mm long DC- wire between connector X1 pin 15 and connector X8 pin 5, 2. Connect the 210mm long DC- wire to connector X1 pin 1. <p style="text-align: center;"><i>Figure 3.21. NFE wire harness modification</i></p>

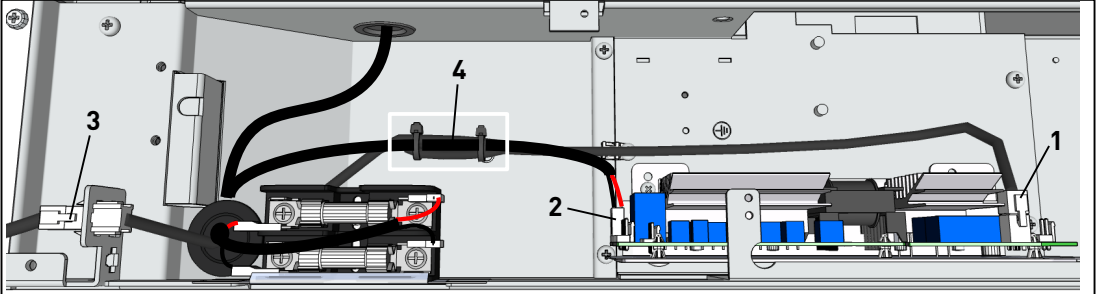
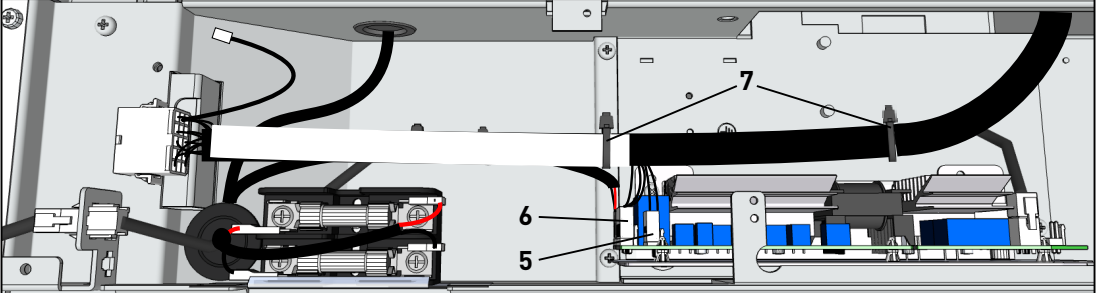
<p>4</p>	<ol style="list-style-type: none"> 1. Connect the 48V_{DC} fan extension wire (70CMR00188) supplied in the retrofit kit to connector X81 on the fan power supply, 2. Connect the DC supply wire to connector X2 on the fan power supply, 3. Connect the 48V_{DC} fan extension wire to the fan supply cable, 4. Use two of the cable ties (MC00178) supplied in the retrofit kit to tie together the excess 48V_{DC} fan extension wire. 5. Connect the fan control FB wire to connector X3 on the fan power supply, 6. Connect the fan control wire to connector X8 on the fan power supply, 7. Use two of the cable ties (MC00178) supplied in the retrofit kit to tie together the wire harness and fan power supply wire. <div style="display: flex; justify-content: space-between;">   </div> <p style="text-align: center;"><i>Figure 3.22. Connecting wires</i></p>
<p>5</p>	<p>Check that the power supply and DC fan function. See the testing instructions in Chapter 9.</p> <p>If the fan and power supply work properly, re-assemble the drive. See the instructions below.</p>
<p>6</p>	<p>Re-attach the sheet cover. See the instructions in Step 3 on page 21.</p>

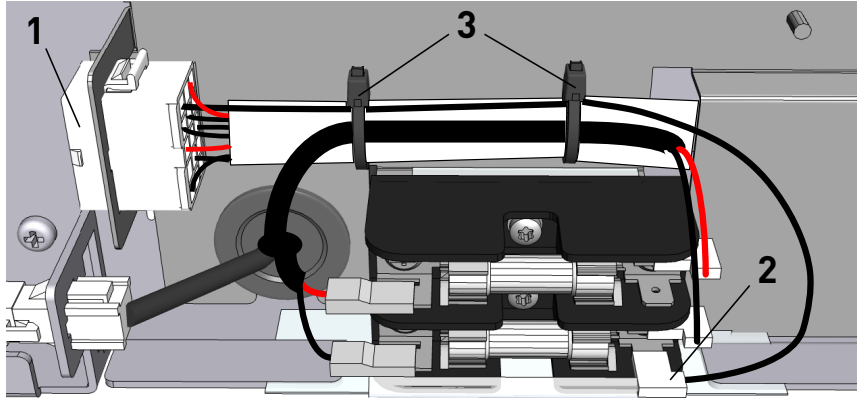
<p>7</p>	<ol style="list-style-type: none"> 1. Place the NFE wire harness connector X1 on the sheet cover connector holder, 2. Connect the wire harness DC- wire on the fuse base, 3. Use two of the cable ties (MC00178) supplied in the retrofit kit to tie together the wire harness and DC wires.  <p style="text-align: center;"><i>Figure 3.23. NFE wire harness and DC wiring</i></p>
<p>8</p>	<p>Re-attach the covers. See the instructions in Step 1 on page 13.</p>
<p>9</p>	<p>Attach the 'Product modified'-sticker (70CPL00062) supplied in the retrofit kit in a visible place on the front side of the drive. On the sticker, write "DC fan retrofit" and the installation date.</p> <p>If there are parallel NFE units, place a sticker on all of them.</p>

4. FR9 RETROFIT KIT INSTALLATION

4.1 RETROFIT KIT CONTENTS

Table 4.1. FR9 DC fan retrofit assembly kits for 500/690V and 230V drives (spare part numbers: 60S00966 and 60S01054)

#	Item number	Item description	Pcs
1	70CPA00551	FR9 Maintenance DC fan assembly	1
2	70CMC03903	DC/DC fan supply assembly, 48V full-bridge 240W (in 500/690V kit)	1
	70CMC05042	DC/DC fan supply assembly, 48V full-bridge 240W (in 230V kit)	
3	MC00031	M4x8-DIN7500CE-Thread Forming-Zn-Pz	2
4	MC00046	M5x10-DIN7500CE-Thread Forming-Zn-Pz	4
5	70CPL00062	'Product modified'-sticker	1

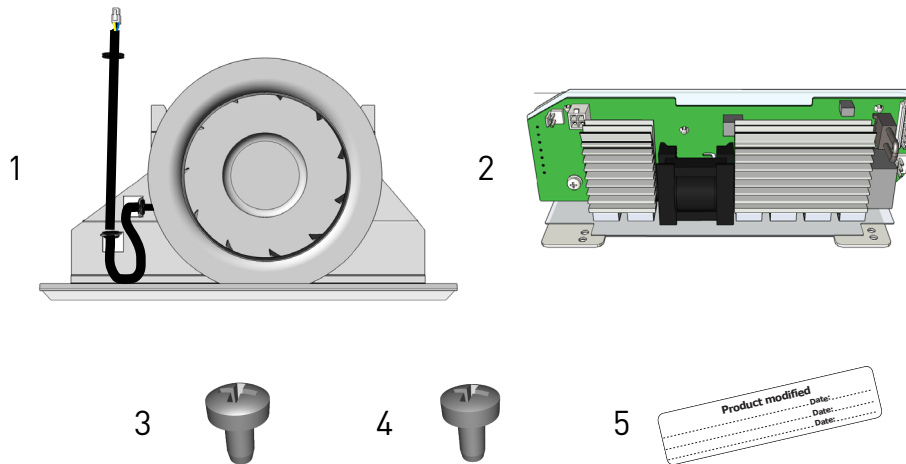

Figure 4.1. FR9 DC fan retrofit assembly kit for 500/690V and 230V drives (spare part numbers: 60S00966 and 60S01054)

4.2 REMOVING THE AC FAN AND FAN INVERTER

Before installing the new DC fan and DC power supply, remove the old AC fan and fan inverter.

Parts to remove:

- AC fan
- Fan inverter
- Fan capacitor
- Isolation transformer assembly

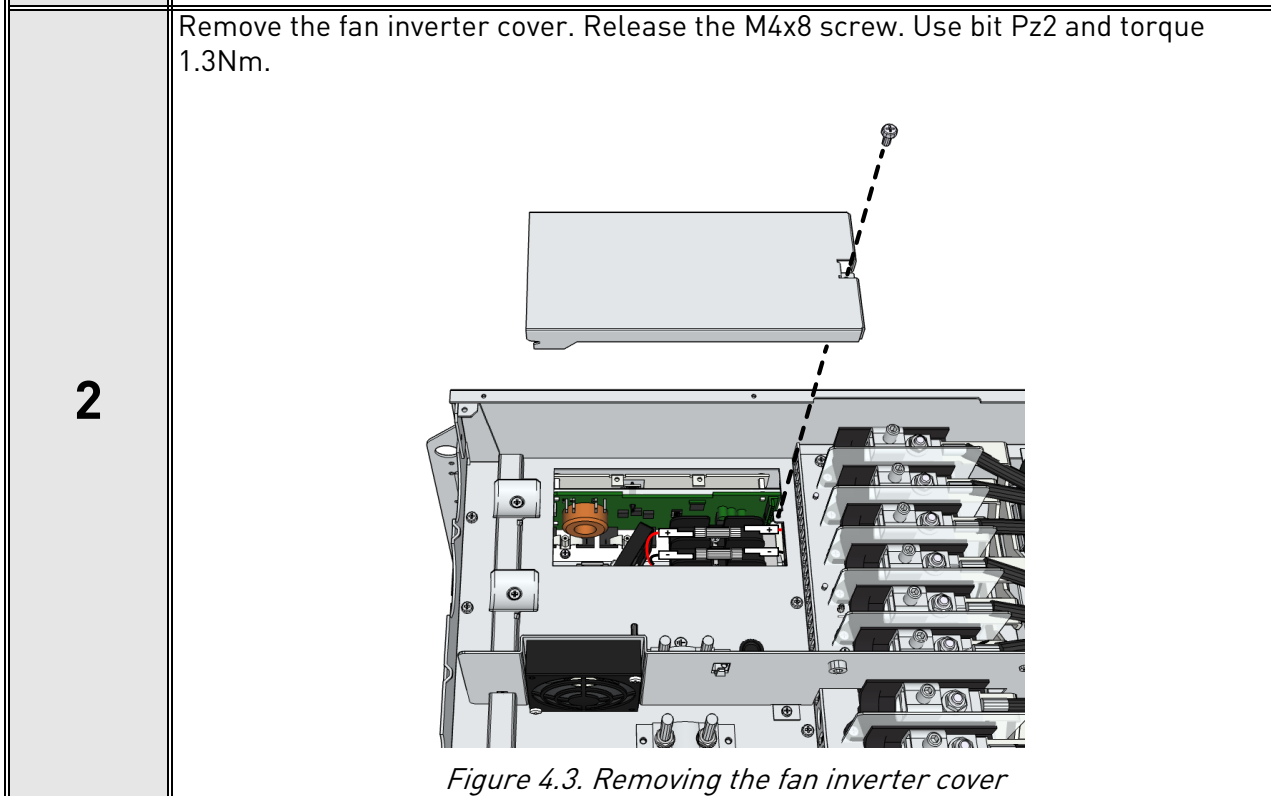
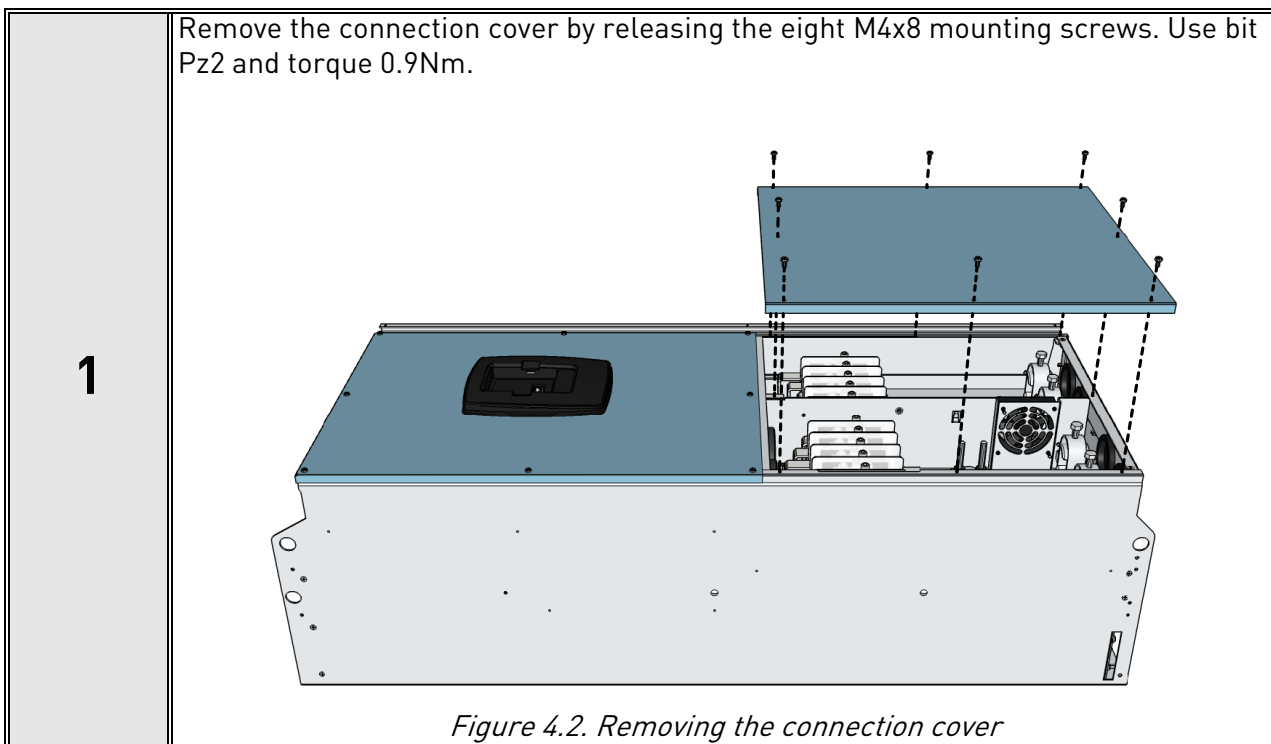

3

Disconnect the isolation transformer wires:

1. Black and Blue from the fan inverter,
2. Brown and Blue from the fan capacitor wires.

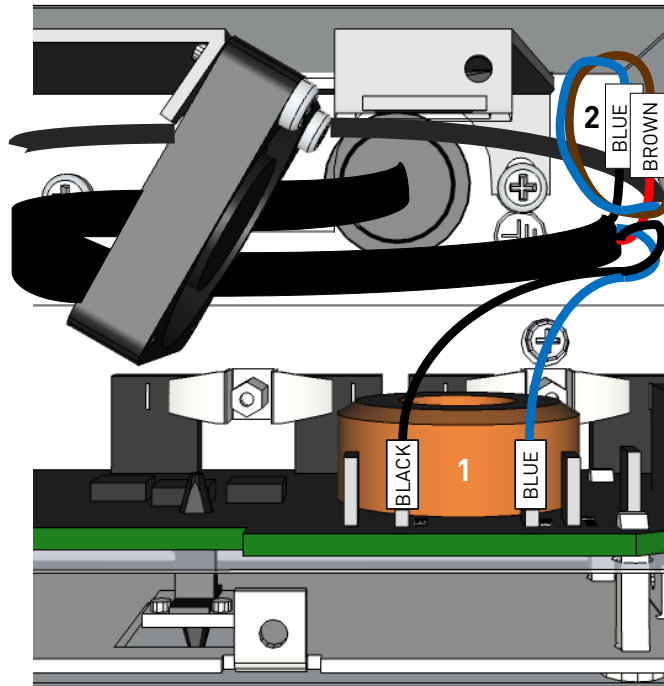

Figure 4.4. Isolation transformer wires

4

1. Disconnect the internal fan supply wire,
2. Disconnect the DC supply wire from fan inverter connector X2,
3. Disconnect the fan supply wire from fan inverter connector X8,
4. Disconnect the DC wires from the fuse base.

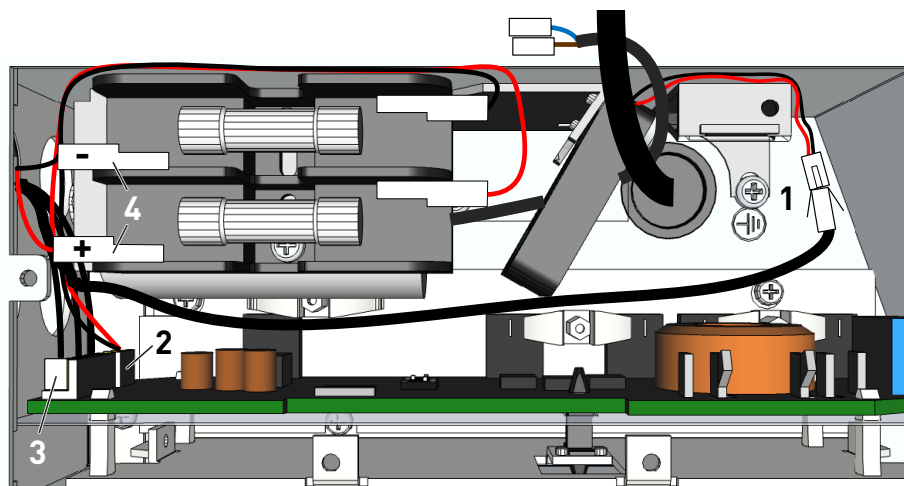

Figure 4.5. Fan inverter, internal fan and fuse base wires

5

Remove the fuse base assembly. Release the two M5x10 mounting screws. Use bit Pz2 and torque 2.3Nm.

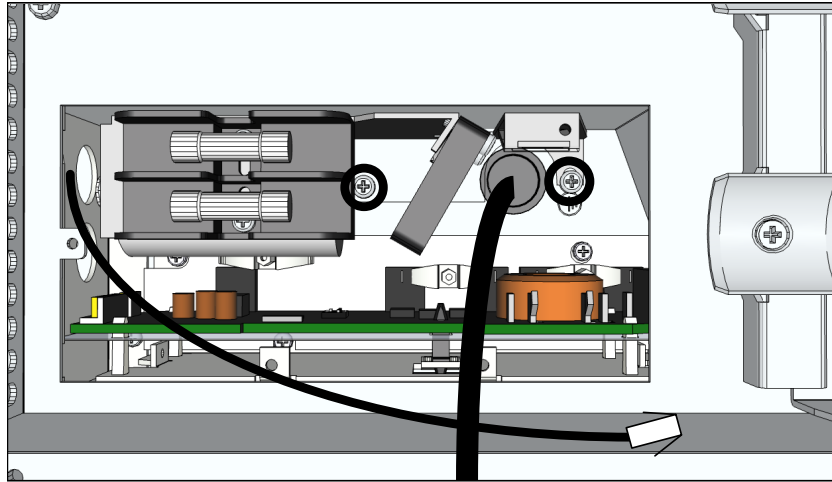

Figure 4.6. Removing the fuse base assembly

6

Remove the fan capacitor from the fuse base assembly. Release the mounting nut. Use a 19mm bit and torque 5Nm.

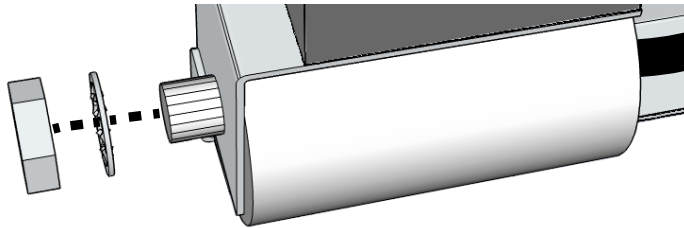

Figure 4.7. Removing the fan capacitor from the fuse base assembly

7

Remove the three M4x8 fan inverter mounting screws. Use bit Pz2 and torque 2.3Nm. Turn the fan inverter slightly sideways and take it out.

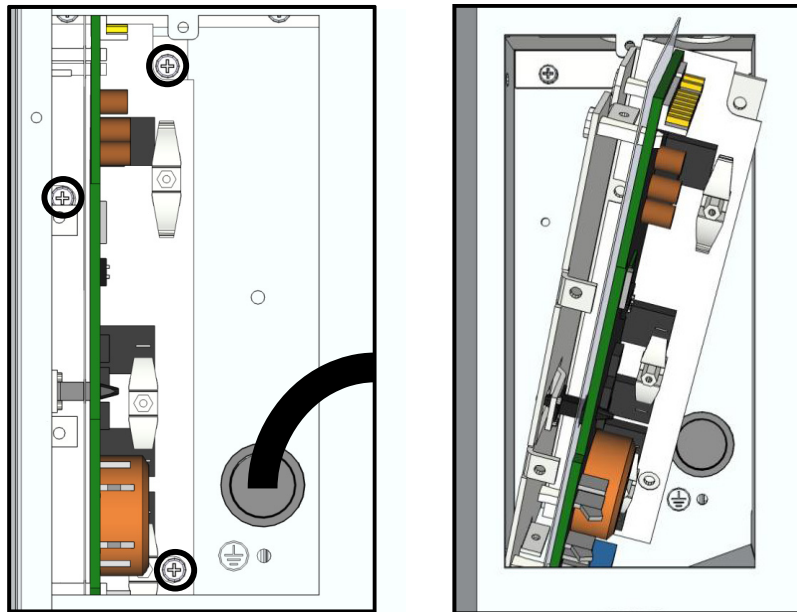

Figure 4.8. Removing the fan inverter

8

Disconnect the fan power supply cable. Carefully release the grommet, pull out the AC fan supply cable and disconnect it from the connector.

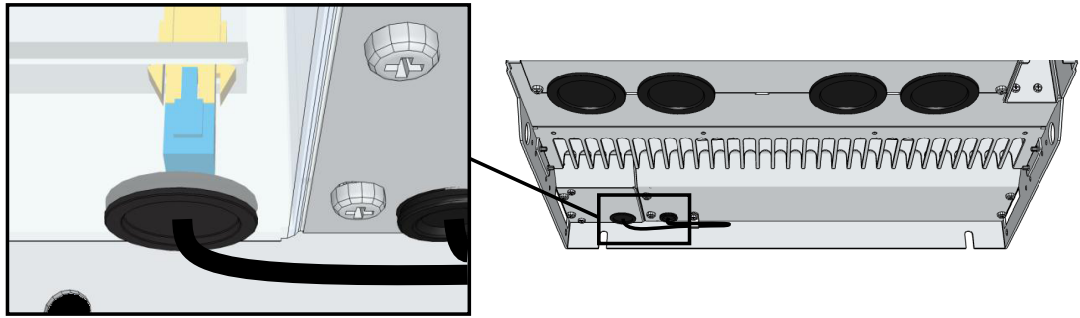

Figure 4.9. AC fan supply cable

9

Remove the four M5x10 fan mounting screws. Use bit Pz2 and torque 3.2Nm. Pull out the AC fan.

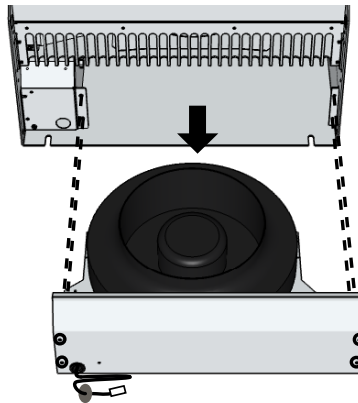

Figure 4.10. Removing the AC fan

10

Remove the isolation transformer assembly. Pull out the isolation transformer cable and grommet and release the two M5x10 mounting screws. Use bit Pz2 and torque 3.2Nm.

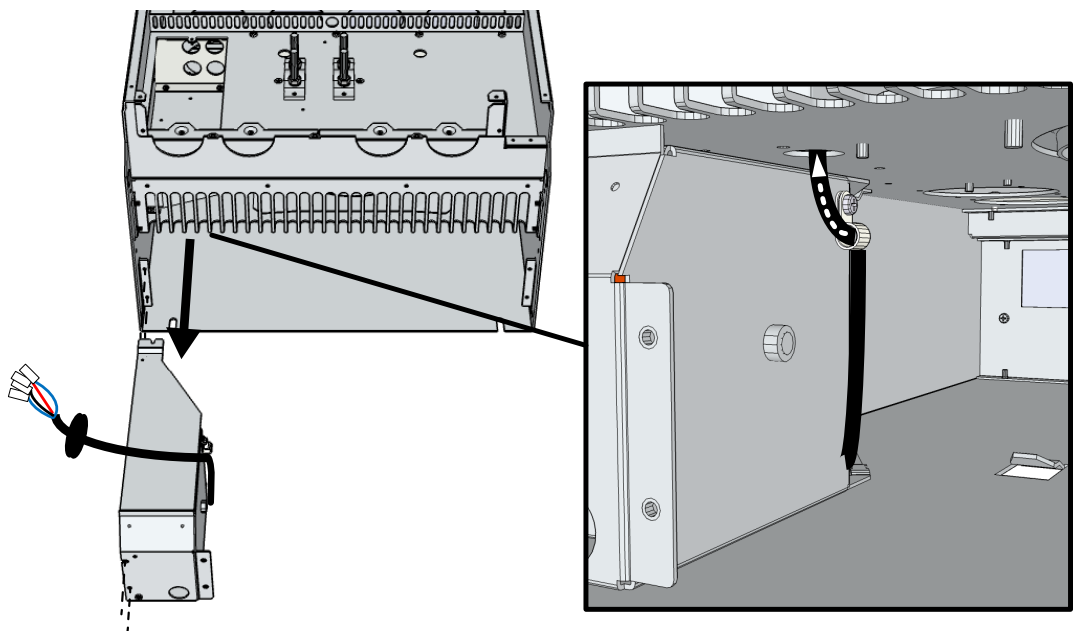
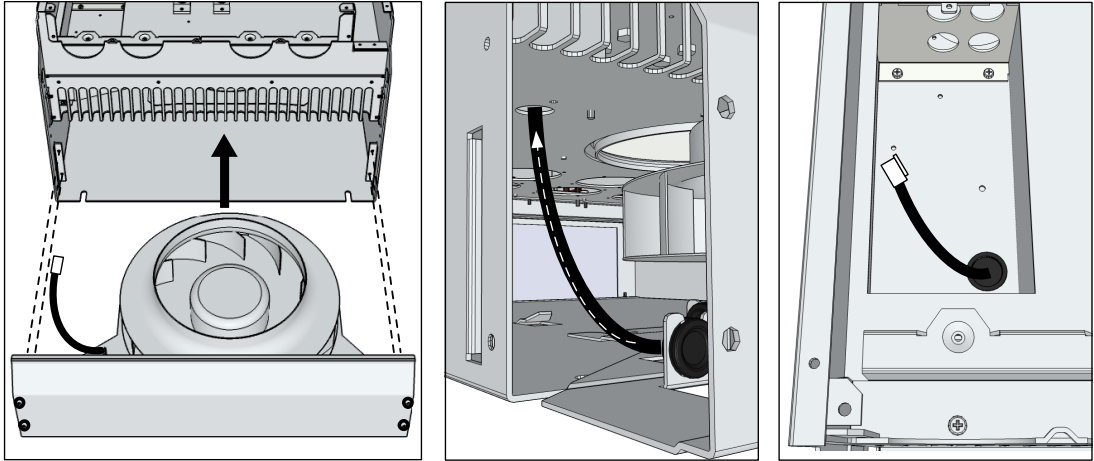
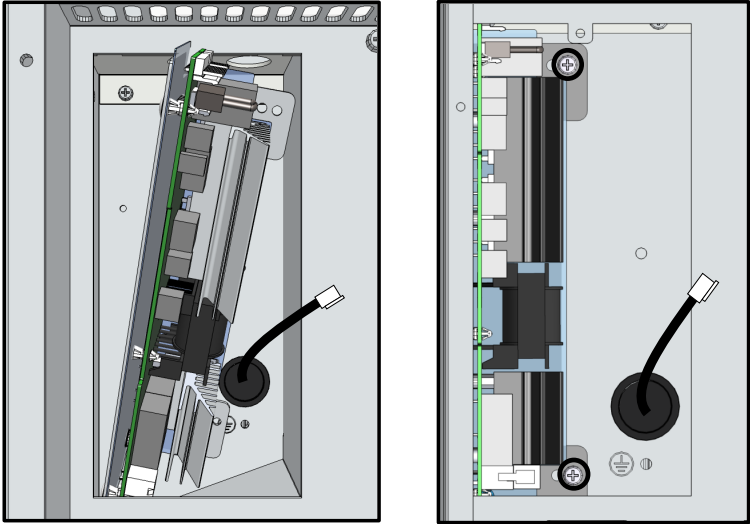
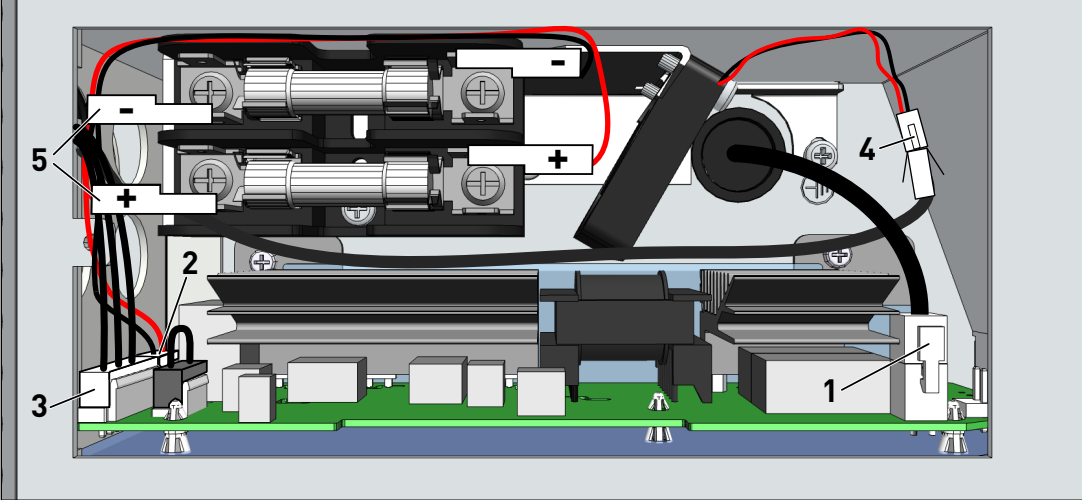

Figure 4.11. Removing the isolation transformer assembly

4.3 DC FAN AND DC POWER SUPPLY INSTALLATION

Once the AC fan and other old parts have been removed (see Chapter 4.2), install the new DC fan and DC power supply.

<p style="text-align: center; font-size: 2em; font-weight: bold;">1</p>	<p>Install the DC fan. Use the four M5x10 mounting screws (MC00046) supplied in the retrofit kit to mount the fan. Use bit Pz2 and torque 3.2Nm.</p> <p>NOTE! Lead in the fan supply cable before mounting the fan and close the hole with the grommet.</p>  <p style="text-align: center;"><i>Figure 4.12. DC fan mounting and fan supply cable routing</i></p>
<p style="text-align: center; font-size: 2em; font-weight: bold;">2</p>	<p>Install the DC power supply. Use the two M4x8 screws (MC00031) supplied in the retrofit kit. Use bit Pz2 and torque 2.3Nm.</p>  <p style="text-align: center;"><i>Figure 4.13. Installing the fan power supply</i></p>
<p style="text-align: center; font-size: 2em; font-weight: bold;">3</p>	<p>Re-attach the fuse base assembly. See the instructions in Step 5 on page 31.</p>

<p>4</p>	<ol style="list-style-type: none"> 1. Connect the DC fan power supply wire to power supply connector X81, 2. Connect the DC supply wire to power supply connector X2, 3. Connect the fan control wire to power supply connector X8, 4. Connect the internal fan supply wire to the internal fan, 5. Connect the fuse base wires.  <p style="text-align: center;"><i>Figure 4.14. Fan power supply, fuse base and internal fan wiring</i></p>
<p>5</p>	<p>Check that the power supply and DC fan function. See the testing instructions in Chapter 9.</p> <p>If the fan and power supply work properly, re-assemble the drive. See the instructions below.</p>
<p>6</p>	<p>Close the fan inverter cover. See the instructions in Step 2 on page 29.</p>
<p>7</p>	<p>Re-attach the connection cover. See the instructions in Step 1 on page 29.</p>
<p>8</p>	<p>Attach the 'Product modified'-sticker (70CPL00062) supplied in the retrofit kit in a visible place on the front side of the drive. On the sticker, write "DC fan retrofit" and the installation date.</p>

5. FI10 AND FI12 RETROFIT KIT INSTALLATION

5.1 RETROFIT KIT CONTENTS

Table 5.1. FI10 DC fan retrofit assembly kit (spare part number: 60S00969)

#	Item number	Item description	Pcs
1	70CPA00556	FI9 Maintenance DC fan assembly	1
2	70CPA00557	DC fan supply assembly, 48V, 240W	1
3	MC00046	M5x10-DIN7500CE-Thread Forming-Zn-Pz	8
4	MC00178	3.6x205 white/black cable tie	3
5	70CPL00062	'Product modified'-sticker	1

Table 5.2. FI12 DC fan retrofit assembly kit (spare part number: 60S00972)

#	Item number	Item description	Pcs
1	70CPA00556	FI9 Maintenance DC fan assembly	2
2	70CPA00557	DC fan supply assembly, 48V, 240W	2
3	MC00046	M5x10-DIN7500CE-Thread Forming-Zn-Pz	16
4	MC00178	3.6x205 white/black cable tie	6
5	70CPL00062	'Product modified'-sticker	2

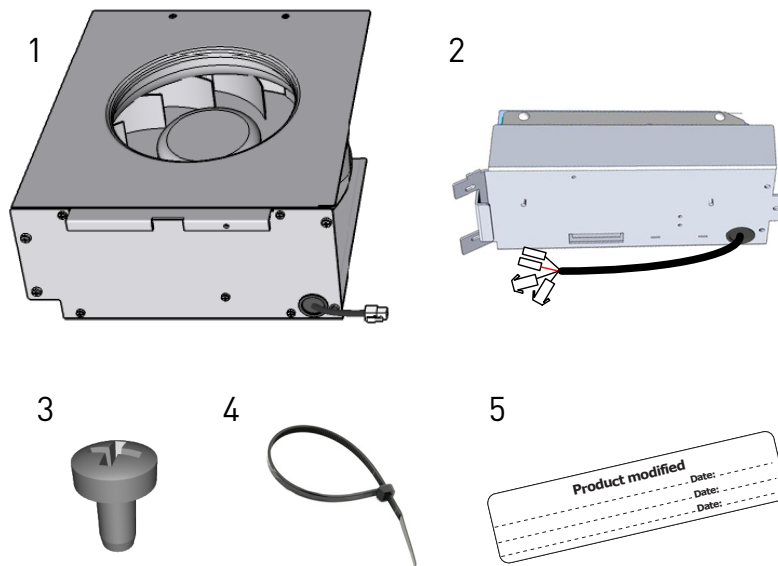

Figure 5.1. FI10 and FI12 DC fan retrofit assembly kits (spare part numbers: 60S00969 and 60S00972)

5.2 REMOVING THE AC FAN AND FAN INVERTER

Before installing the new DC fan and DC power supply, remove the old AC fan and fan inverter. Parts to remove:

- AC fan
- Fan inverter assembly

NOTE! The following instructions apply to both FI10 and FI12, since the FI12 unit consists of two FI10 units.

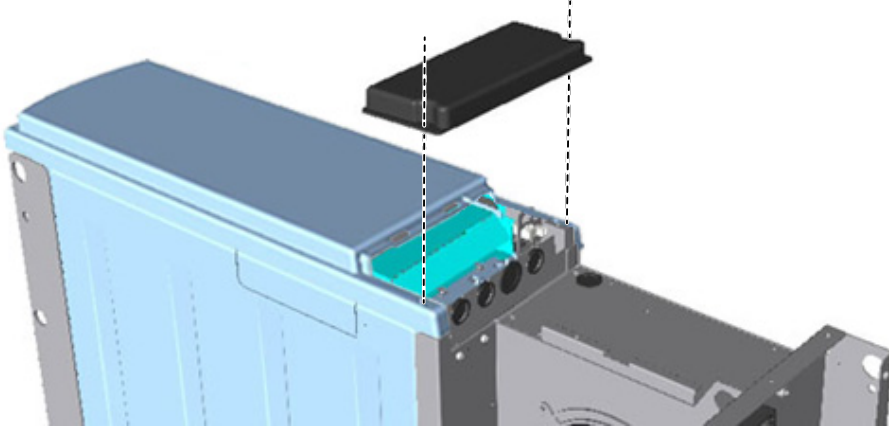
1	<p>Take off the connection cover. Remove the two M5x16 mounting screws. Use torque 3Nm.</p>  <p style="text-align: center;"><i>Figure 5.2. Removing the connection cover</i></p>
---	---

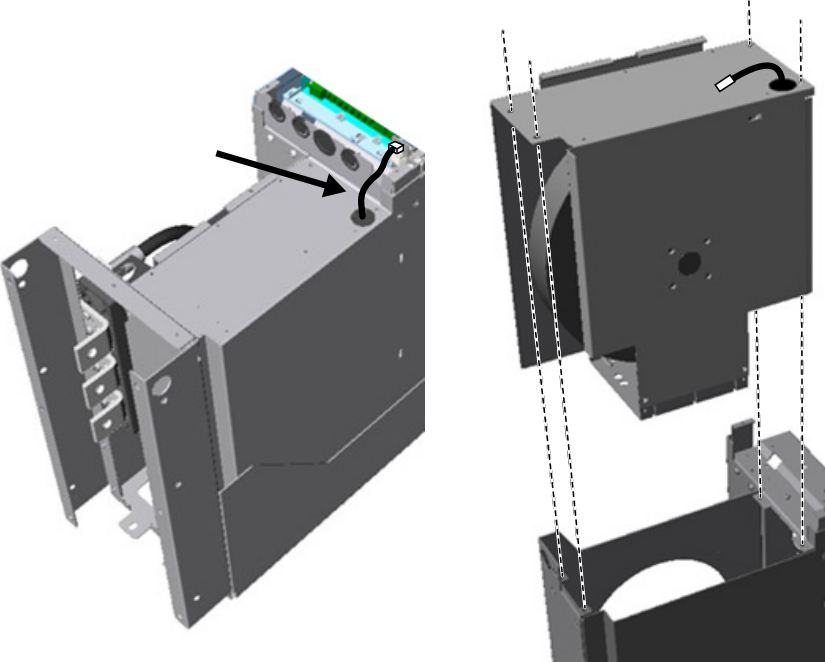
2	<p>Disconnect the fan supply wire from the connector. Release the AC fan. Remove the four M5x10 mounting screws with bit Pz2 and torque 3.5Nm and pull out the fan.</p>  <p style="text-align: center;"><i>Figure 5.3. Removing the AC fan</i></p>
---	--

3

Disconnect the fan supply inverter wires from the connector holder and fuse base.

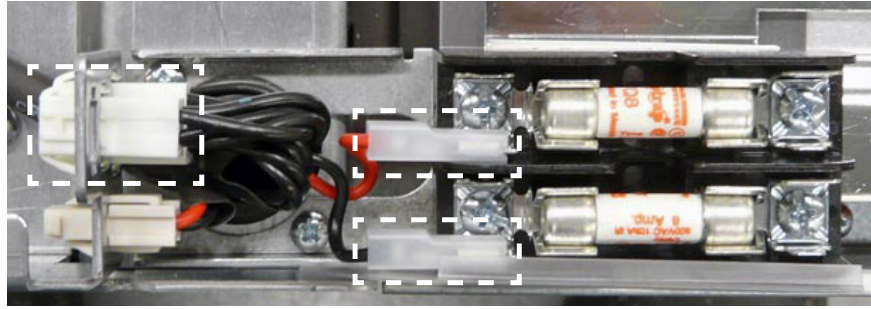

Figure 5.4. Fan inverter wires

4

Cut off the cable ties holding the fan inverter cable and pull the cable and grommet out through the lead-in hole.

Remove the four M5x10 fan inverter mounting screws. Use bit Pz2 and torque 3.5Nm. Pull out the fan inverter assembly.

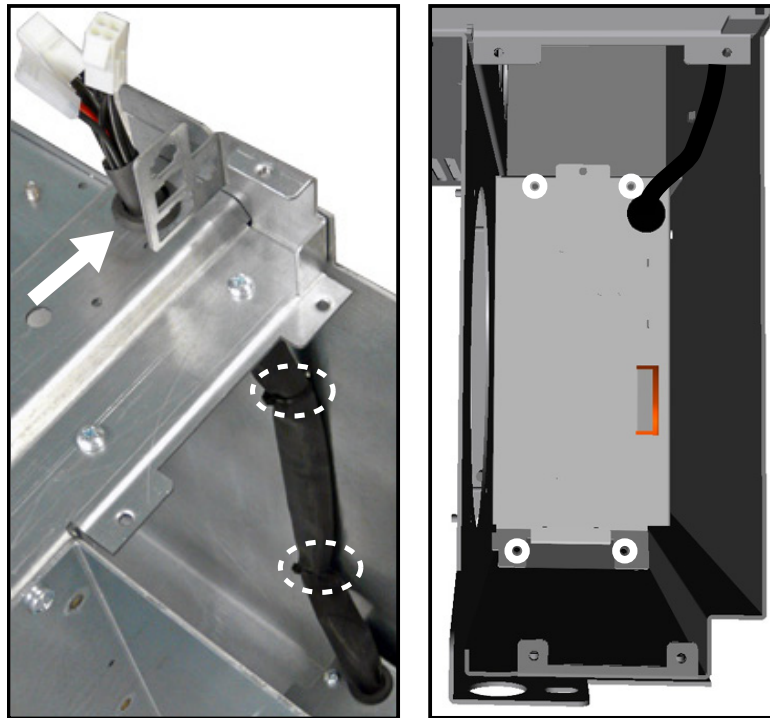

Figure 5.5. Removing the fan inverter assembly

5.3 DC FAN AND DC POWER SUPPLY INSTALLATION

Once the AC fan and other old parts have been removed (see Chapter 5.2), install the new DC fan and DC power supply.

NOTE! The following instructions apply to both FI10 and FI12, since the FI12 unit consists of two FI10 units.

1	<p>Install the DC power supply assembly. The power supply is mounted in the same way as the old fan inverter assembly (see Figure 5.5 on page 37). Use the four M5x10 mounting screws (MC00046) supplied in the retrofit kit.</p> <p>Use the cable ties (MC00178) supplied in the retrofit kit to attach the cable to the frame.</p>
2	<p>Connect the fan power supply wires to the connector holder and fuse base as shown in Figure 5.4 on page 37.</p>
3	<p>Install the DC fan. The fan is mounted in the same way as the old AC fan (see Figure 5.3 on page 36). Use the four M5x10 mounting screws (MC00046) supplied in the retrofit kit.</p>
4	<p>Check that the power supply and DC fan function. See the testing instructions in Chapter 9.</p>
5	<p>If the fan and power supply work properly, re-attach the connection cover. See Figure 5.2 on page 36.</p>
6	<p>Attach the 'Product modified'-sticker (70CPL00062) supplied in the retrofit kit in a visible place on the front side of the drive. On the sticker, write "DC fan retrofit" and the installation date.</p> <p>In FI12, place a sticker on both units.</p>

6. FR10 AND FR12 RETROFIT KIT INSTALLATION

6.1 RETROFIT KIT CONTENTS

Table 6.1. FR10 DC fan retrofit assembly kit (spare part number: 60S00967)

#	Item number	Item description	Pcs
1	70CPA00553	FR10 Maintenance DC fan assembly	2
2	70CPA00552	DC fan supply assembly, 48V, 240W	1
3	MC00042	M6x20-DIN6900-3-Combi-Delta-Tx	4
4	MC00046	M5x10-DIN7500CE-Thread Forming-Zn-Pz	12
5	70CPL00062	'Product modified'-sticker	1

Table 6.2. FR12 DC fan retrofit assembly kit (spare part number: 60S00970)

#	Item number	Item description	Pcs
1	70CPA00553	FR10 Maintenance DC fan assembly	4
2	70CPA00552	DC fan supply assembly, 48V, 240W	2
3	MC00042	M6x20-DIN6900-3-Combi-Delta-Tx	8
4	MC00046	M5x10-DIN7500CE-Thread Forming-Zn-Pz	24
5	70CPL00062	'Product modified'-sticker	2

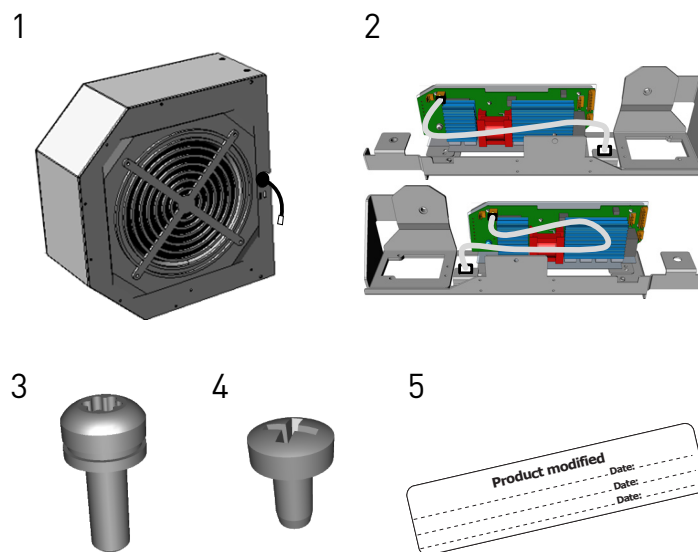

Figure 6.1. FR10 and FR12 DC fan retrofit assembly kits (spare part numbers: 60S00967 and 60S00970)

6.2 REMOVING THE AC FAN AND FAN INVERTER

Before installing the new DC fans and DC power supplies, remove the old AC fans and fan inverters. Parts to remove:

- AC fans
- Fan inverter assemblies

NOTE! The following instructions apply to both FR10 and FR12, since the FR12 unit consists of two FR10 units.

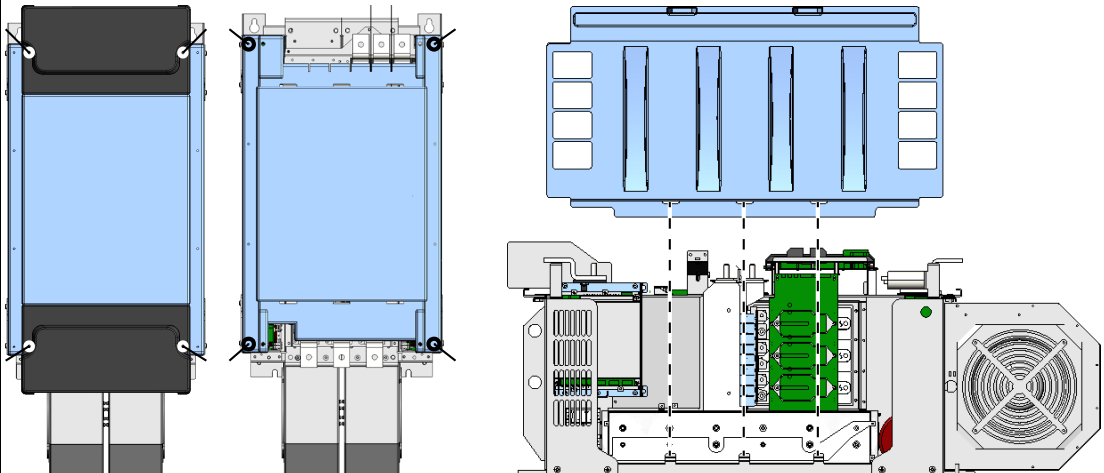
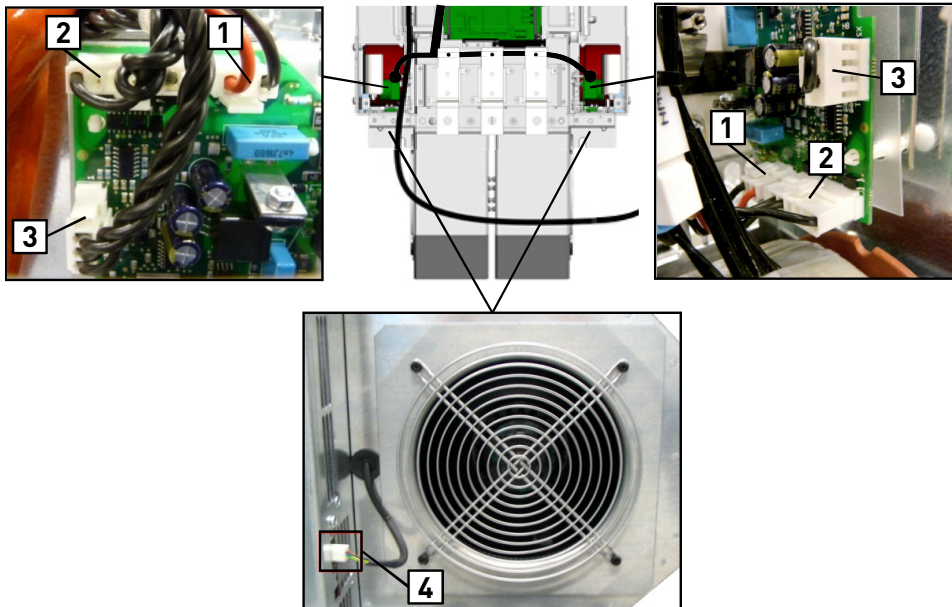
1	<p>Take off the main covers. Remove the M5x16 mounting screws from the connection covers and then the main cover. Use bit Pz2 and torque 2.3Nm. Also take off the side covers.</p>  <p style="text-align: center;"><i>Figure 6.2. Removing the covers</i></p>
2	<p>Disconnect the following wires from the fan inverters:</p> <ol style="list-style-type: none"> 1. DC supply wire from connector X2 2. fan control wire from connector X8 3. fan control FB wire/jumper from connector X3 4. fan supply wire from isolation transformer connector  <p style="text-align: center;"><i>Figure 6.3. Fan inverter wiring</i></p>

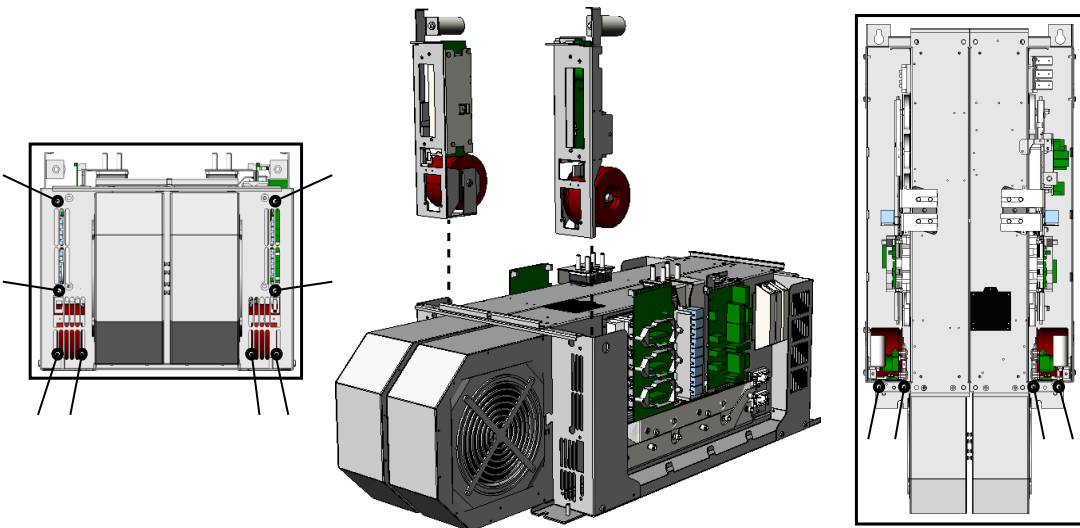
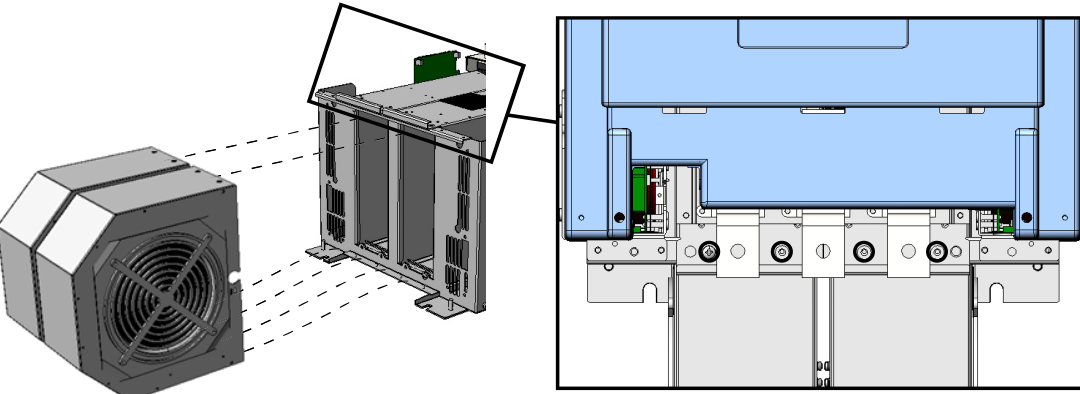
<p style="text-align: center; font-size: 2em; font-weight: bold;">3</p>	<p>Release the fan inverter assemblies. Remove the twelve M5x10 mounting screws. Use bit Pz2 and torque 3Nm. Lift out the fan inverter assemblies.</p>  <p style="text-align: center;"><i>Figure 6.4. Removing the fan inverter assemblies</i></p>
<p style="text-align: center; font-size: 2em; font-weight: bold;">4</p>	<p>Release the AC fans. Remove the four M6x20 mounting screws with bit Tx30 and torque 3Nm and take off the fans.</p>  <p style="text-align: center;"><i>Figure 6.5. Removing the main fans</i></p>

6.3 DC FAN AND DC POWER SUPPLY INSTALLATION

Once the AC fans and other old parts have been removed (see Chapter 6.2), install the new DC fans and DC power supplies.

NOTE! The following instructions apply to both FR10 and FR12, since the FR12 unit consists of two FR10 units.

1	Install the two DC fans. The fans are mounted in the same way as the old AC fans (see Figure 6.5 on page 41). Use the four M6x20 mounting screws (MC00042) supplied in the retrofit kit.
2	Install the two DC power supply assemblies. The power supplies are mounted in the same way as the old fan inverter assemblies (see Figure 6.4 on page 41). Use the M5x10 screws (MC00046) supplied in the retrofit kit.
3	<p>Connect the FR10 wires on the power supplies:</p> <ol style="list-style-type: none"> 1. DC supply wire to connector X2 2. fan control wire to connector X8 3. fan control FB wire/jumper to connector X3 4. fan supply wire to DC fan extension wire connector <div style="text-align: center;"> </div> <p style="text-align: center;"><i>Figure 6.6. Fan power supply wiring</i></p>
4	Check that the power supplies and DC fans function. See the testing instructions in Chapter 9.
5	If the fans and power supplies work properly, re-attach the covers. See Figure 6.2 on page 40.
6	<p>Attach the 'Product modified' -sticker (70CPL00062) supplied in the retrofit kit in a visible place on the front side of the drive. On the sticker, write "DC fan retrofit" and the installation date.</p> <p>In FR12, place a sticker on both units.</p>

7. FR11 RETROFIT KIT INSTALLATION

7.1 RETROFIT KIT CONTENTS

Table 7.1. FR11 DC fan retrofit assembly kit (spare part number: 60S00971)

#	Item number	Item description	Pcs
1	70CPA00553	FR10 Maintenance DC fan assembly	3
2	70CPA00560	FR11 DC fan supply assembly, 48V, 240W	3
3	MC00042	M6x20-DIN6900-3-Combi-Delta-Tx	6
4	MC00046	M5x10-DIN7500CE-Thread Forming-Zn-Pz	12
5	MC00058	M8-DIN 6796-Zn-Conical spring washer	1
6	MC00392	M8x16-DIN912-8.8-Zn-Socket Head Cap	1
7	70CPL00062	'Product modified' -sticker	1

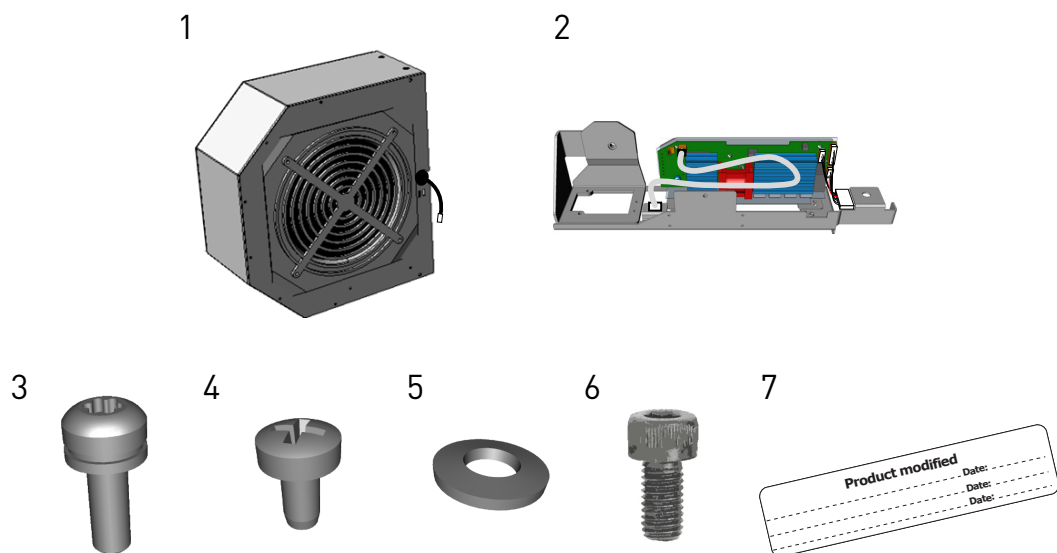

Figure 7.1. FR11 DC fan retrofit assembly kit (spare part number: 60S00971)

7.2 REMOVING THE AC FAN AND FAN INVERTER

Before installing the new DC fans and DC power supplies, remove the old AC fans and fan inverters. Parts to remove:

- AC fans
- Fan inverter assemblies

1	<p>Take off the main covers. Remove the M5x16 mounting screws from the connection covers and then the main cover. Use bit Pz2 and torque 1.9Nm for the connection covers and 2.6Nm for the main cover.</p> <div data-bbox="523 600 1230 1126" data-label="Image"> </div> <p style="text-align: center;"><i>Figure 7.2. Removing the covers</i></p>
2	<ol style="list-style-type: none"> 1. Disconnect the fan supply wires from the fan inverter connectors. 2. Release the AC fans. Remove the M6x20 fan mounting screws with bit Tx30 and torque 4.5Nm and pull out the fans. <div data-bbox="504 1341 1254 1832" data-label="Image"> </div> <p style="text-align: center;"><i>Figure 7.3. Removing the main fans</i></p>

3 Disconnect the DC wires from the fuse base and the three fan inverter connectors.

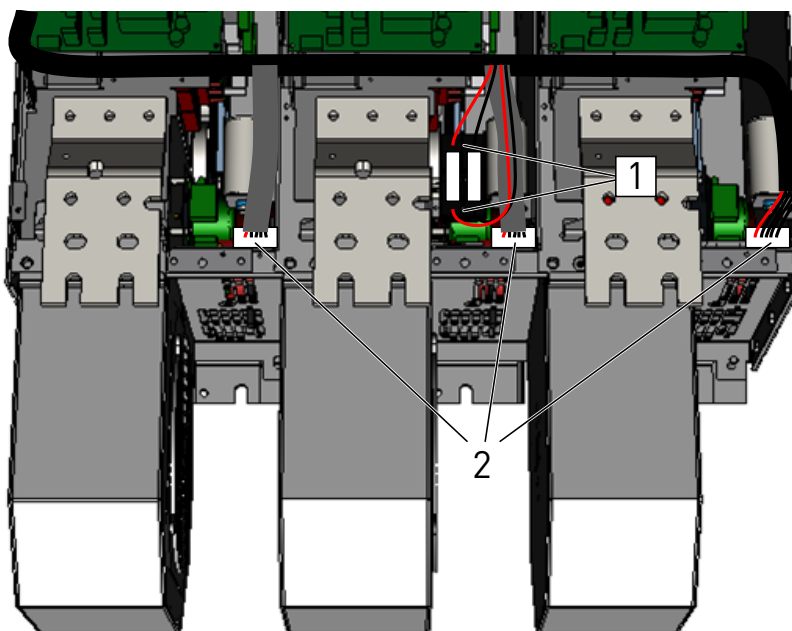

Figure 7.4. Fan inverter assembly wiring

4 Release the fan inverter assemblies. Remove the M5x10 mounting screws. Use bit Pz2 and torque 4.5Nm.

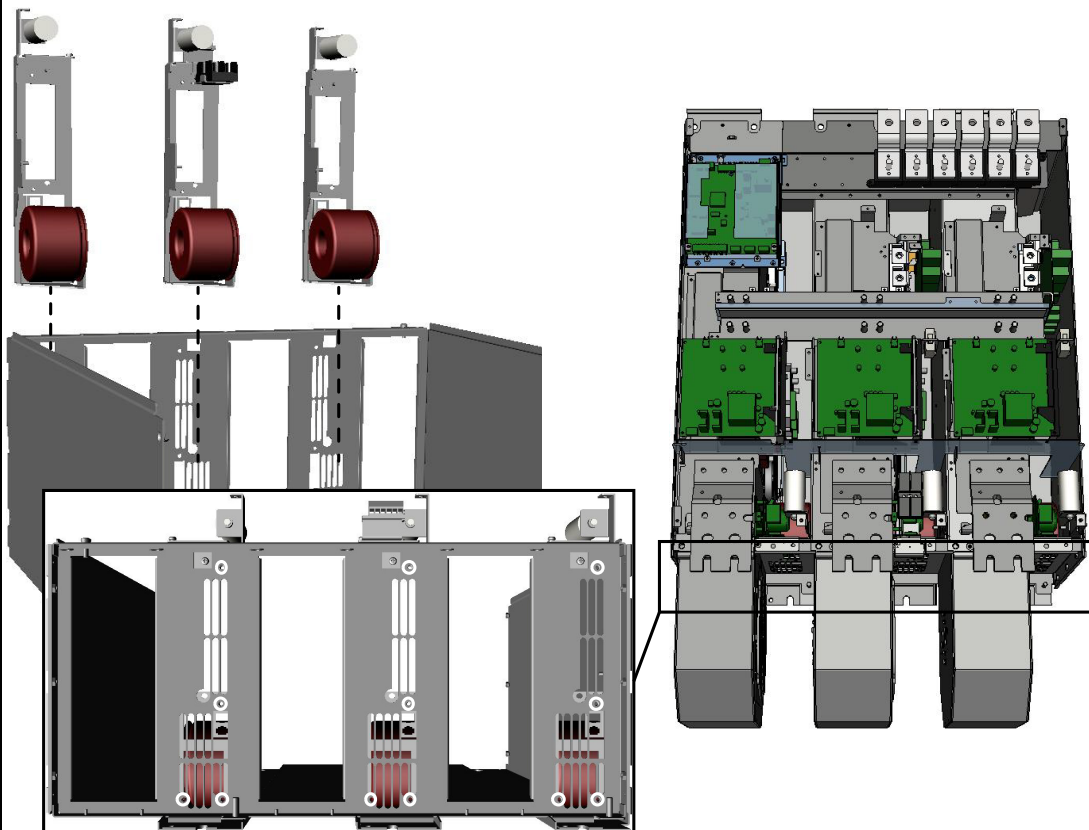

Figure 7.5. Removing the fan inverter assemblies

5

Release the fuse base bracket assembly from the phase V fan inverter assembly. Remove the M8x12 mounting screw. Use a HOP6 bit and torque 5Nm.

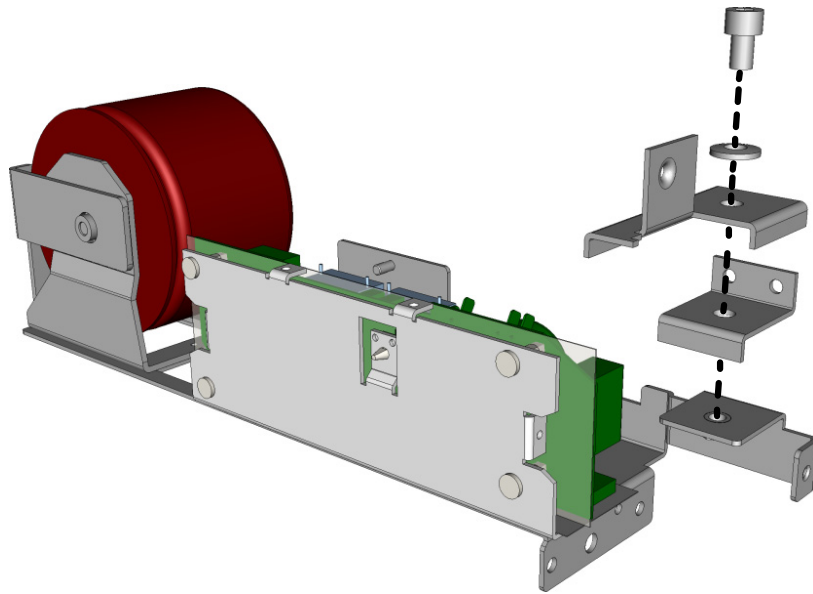

Figure 7.6. Removing the fuse base bracket

7.3 DC FAN AND DC POWER SUPPLY INSTALLATION

Once the AC fans and other old parts have been removed (see Chapter 7.2), install the new DC fans and DC power supplies.

1	Mount the fuse base bracket assembly on one of the DC power supply assemblies as shown in Figure 7.6 on page 46. Use the M8x16 screw (MC00392) and M8 spring washer (MC00058) supplied in the retrofit kit.
2	Install the three DC power supply assemblies. The power supplies are mounted in the same way as the old fan inverter assemblies (see Figure 7.5 on page 45). Use the M5x10 screws (MC00046) supplied in the retrofit kit. NOTE! Mount the DC supply assembly with the fuse base in phase V.
3	Connect the the FR11 wire harness flat cables on the fan power supply connectors and the DC wires on the fuse base. See Figure 7.4 on page 45.
4	Install the three DC fans. The fans are mounted in the same way as the old AC fans (see Figure 7.3 on page 44). Use the four M5x10 mounting screws (MC00046) supplied in the retrofit kit.
5	Check that the power supplies and DC fans function. See the testing instructions in Chapter 9.
6	If the fans and power supplies work properly, re-attach the covers. See Figure 7.2 on page 44.
7	Attach the 'Product modified'-sticker (70CPL00062) supplied in the retrofit kit in a visible place on the front side of the drive. On the sticker, write "DC fan retrofit" and the installation date.

8. FI13-14 AND FR13-14 RETROFIT KIT INSTALLATION

8.1 RETROFIT KIT CONTENTS

Table 8.1. FI13 DC fan retrofit assembly kit (spare part number: 60S00973)

#	Item number	Item description	Pcs
1	70CPA00556	FI9 Maintenance DC fan assembly	3
2	70CPA00557	DC fan supply assembly, 48V, 240W	3
3	70CPE05207	FI13 DC minus chaining wire set	1
4	MC00046	M5x10-DIN7500CE-Thread Forming-Zn-Pz	24
5	MC00178	3.6x205 white/black cable tie	9
6	70CPL00062	'Product modified'-sticker	1

Table 8.2. FI14 DC fan retrofit assembly kit (spare part number: 60S00974)

#	Item number	Item description	Pcs
1	70CPA00556	FI9 Maintenance DC fan assembly	6
2	70CPA00557	DC fan supply assembly, 48V, 240W	6
3	70CPE05207	FI13 DC minus chaining wire set	2
4	MC00046	M5x10-DIN7500CE-Thread Forming-Zn-Pz	48
5	MC00178	3.6x205 white/black cable tie	18
6	70CPL00062	'Product modified'-sticker	2

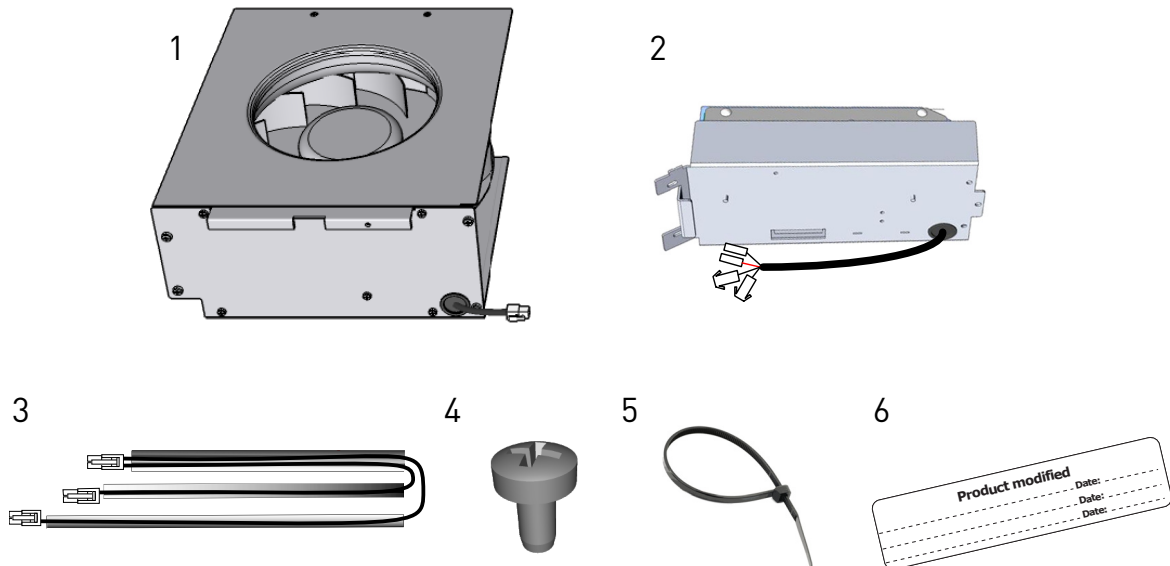

Figure 8.1. FI13 and FI14 DC fan retrofit assembly kits (spare part numbers: 60S00973 and 60S00974)

Table 8.3. FR13 (FI13+2NFE) DC fan retrofit assembly kit (spare part number: 60S00979)

#	Item number	Item description	Pcs
1	70CPA00556	FI9 Maintenance DC fan assembly	5
2	70CPA00557	FI10 DC fan supply assembly, 48V, 240W	3
3	70CMC03903	DC fan supply assembly, 48V full-bridge 240W	2
4	70CMR00188	48V _{DC} fan extension wire	2
5	70CPE05112	DC- additional wire kit	2
6	70CPE05207	FI13 DC minus chaining wire set	1
7	MC00031	M4x8-DIN7500CE-Thread Forming-Zn-Pz	4
8	MC00046	M5x10-DIN7500CE-Thread Forming-Zn-Pz	32
9	MC00178	3.6x205 white/black cable tie	21
10	MC00705	Holder TA1S8 M4	2
11	70CPL00062	'Product modified'-sticker	3
12	PP13101	FR13 wire harness for 2-NFE	1

Table 8.4. FR13 (FI13+3NFE) DC fan retrofit assembly kit (spare part number: 60S00980)

#	Item number	Item description	Pcs
1	70CPA00556	FI9 Maintenance DC fan assembly	6
2	70CPA00557	FI10 DC fan supply assembly, 48V, 240W	3
3	70CMC03903	DC fan supply assembly, 48V full-bridge 240W	3
4	70CMR00188	48V _{DC} fan extension wire	3
5	70CPE05112	DC- additional wire kit	3
6	70CPE05207	FI13 DC minus chaining wire set	1
7	MC00031	M4x8-DIN7500CE-Thread Forming-Zn-Pz	6
8	MC00046	M5x10-DIN7500CE-Thread Forming-Zn-Pz	36
9	MC00178	3.6x205 white/black cable tie	27
10	MC00705	Holder TA1S8 M4	3
11	70CPL00062	'Product modified'-sticker	4
13	PP13100	FR13 wire harness for 3-NFE	1

Table 8.5. FR13 (FI13+4NFE) DC fan retrofit assembly kit (spare part number: 60S00981)

#	Item number	Item description	Pcs
1	70CPA00556	FI9 Maintenance DC fan assembly	7
2	70CPA00557	FI10 DC fan supply assembly, 48V, 240W	3
3	70CMC03903	DC fan supply assembly, 48V full-bridge 240W	4
4	70CMR00188	48V _{DC} fan extension wire	4
5	70CPE05112	DC- additional wire kit	4
6	70CPE05207	FI13 DC minus chaining wire set	1
7	MC00031	M4x8-DIN7500CE-Thread Forming-Zn-Pz	8
8	MC00046	M5x10-DIN7500CE-Thread Forming-Zn-Pz	40
9	MC00178	3.6x205 white/black cable tie	33
10	MC00705	Holder TA1S8 M4	4
11	70CPL00062	'Product modified'-sticker	5
14	PP13108	FR13 wire set 12-pulse	1

Table 8.6. FR14 (FI14+3NFE) DC fan retrofit assembly kit (spare part number: 60S00982)

#	Item number	Item description	Pcs
1	70CPA00556	FI9 Maintenance DC fan assembly	9
2	70CPA00557	FI10 DC fan supply assembly, 48V, 240W	6
3	70CMC03903	DC fan supply assembly, 48V full-bridge 240W	3
4	70CMR00188	48V _{DC} fan extension wire	3
5	70CPE05112	DC- additional wire kit	3
6	70CPE05207	FI13 DC minus chaining wire set	2
7	MC00031	M4x8-DIN7500CE-Thread Forming-Zn-Pz	6
8	MC00046	M5x10-DIN7500CE-Thread Forming-Zn-Pz	60
9	MC00178	3.6x205 white/black cable tie	36
10	MC00705	Holder TA1S8 M4	3
11	70CPL00062	'Product modified'-sticker	5
13	PP13100	FR13 wire harness for 3-NFE	1

Table 8.7. FR14 (FI14+4NFE) DC fan retrofit assembly kit (spare part number: 60S00983)

#	Item number	Item description	Pcs
1	70CPA00556	FI9 Maintenance DC fan assembly	10
2	70CPA00557	FI10 DC fan supply assembly, 48V, 240W	6
3	70CMC03903	DC fan supply assembly, 48V full-bridge 240W	4
4	70CMR00188	48V _{DC} fan extension wire	4
5	70CPE05112	DC- additional wire kit	4
6	70CPE05207	FI13 DC minus chaining wire set	2
7	MC00031	M4x8-DIN7500CE-Thread Forming-Zn-Pz	8
8	MC00046	M5x10-DIN7500CE-Thread Forming-Zn-Pz	64
9	MC00178	3.6x205 white/black cable tie	42
10	MC00705	Holder TA1S8 M4	4
11	70CPL00062	'Product modified'-sticker	6
12	PP13101	FR13 wire harness for 2-NFE	2

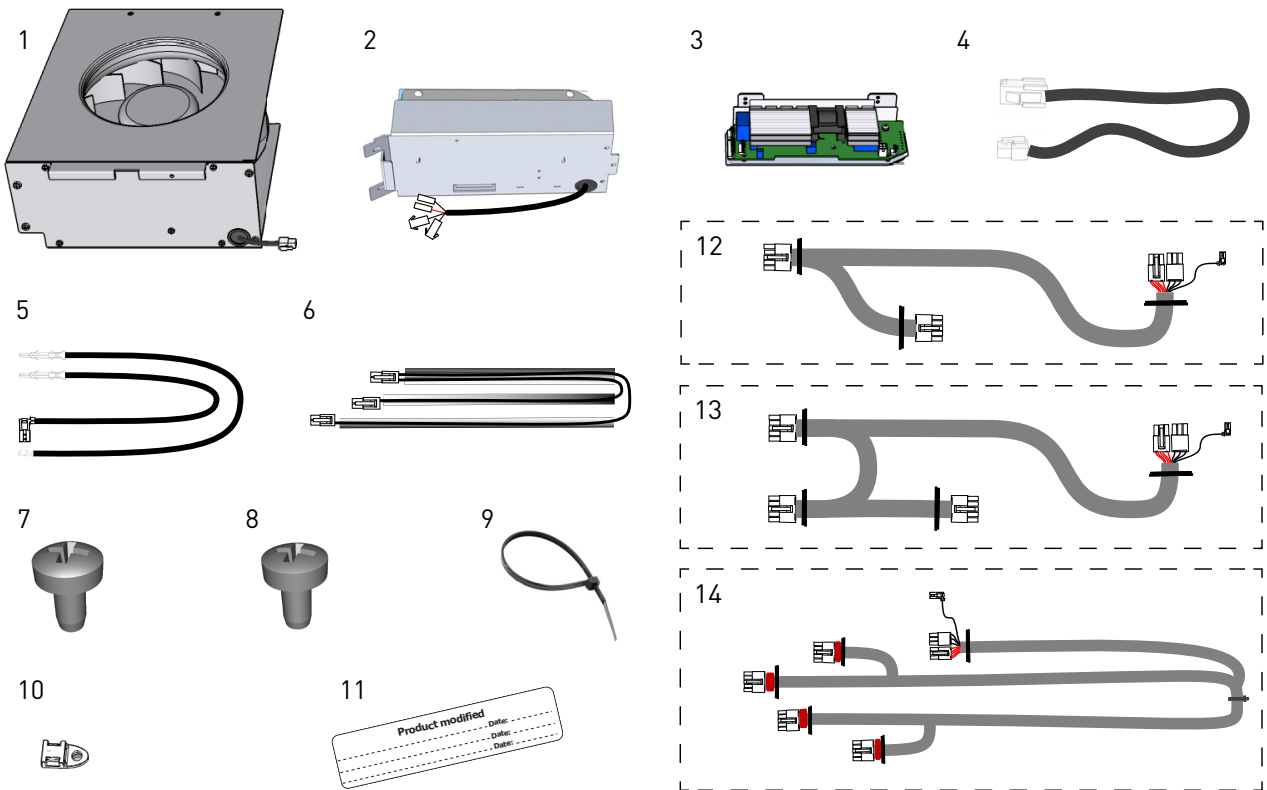

Figure 8.2. FR13 and FR14 DC fan retrofit assembly kits (spare part numbers: 60S00979-60S00983). Part 12 is included only in kits 60S00979 and 60S00983; part 13 is included only in kits 60S00980 and 60S00982; part 14 is included only in kit 60S00981.

8.2 REMOVING THE AC FAN AND FAN INVERTER

Before installing the new DC fans and DC power supplies, remove the old AC fans and fan inverters. Parts to remove:

- AC fans
- Fan inverter assemblies

8.2.1 INSTRUCTIONS FOR FI13 AND FI14

NOTE! The following instructions apply to both FI13 and FI14, since the FI14 unit consists of two FI13 units.

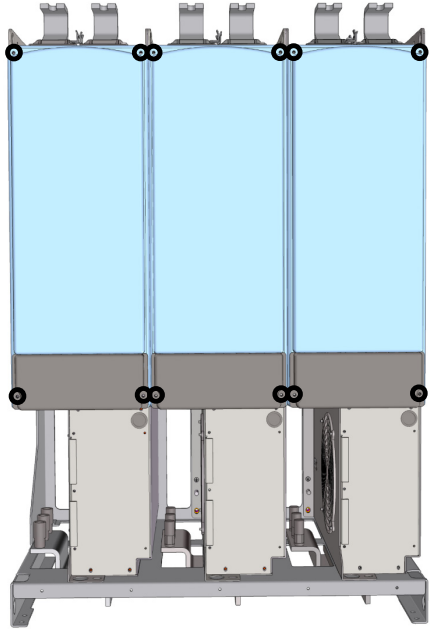
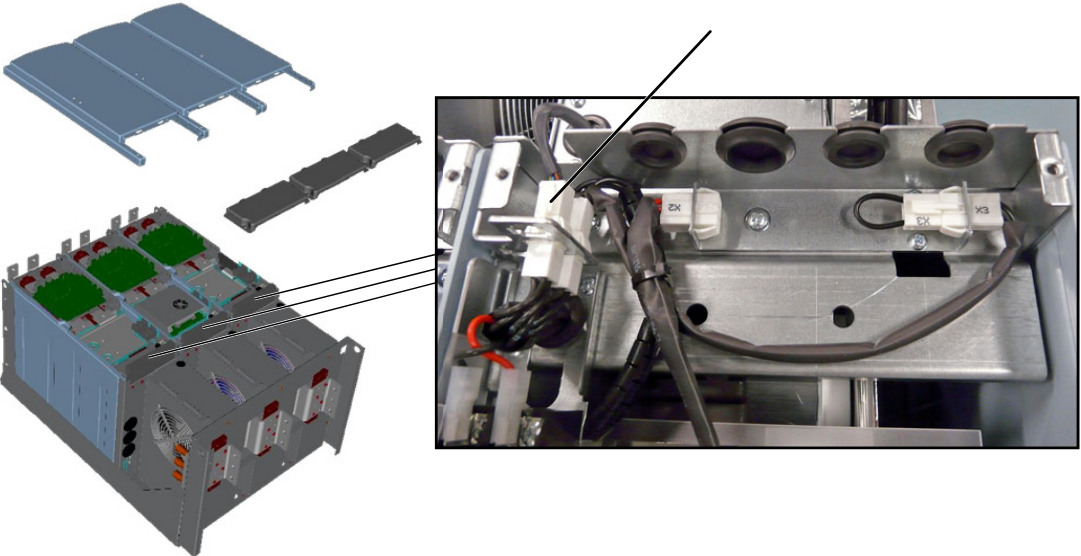
<h1>1</h1>	<p>Take off the front and connection covers. Remove the M5x16 mounting screws. Use bit Pz2 and torque 1.65Nm.</p>  <p style="text-align: center;"><i>Figure 8.3. Removing the covers</i></p>
<h1>2</h1>	<p>Disconnect the fan supply wires from the connectors.</p>  <p style="text-align: center;"><i>Figure 8.4. Fan supply wires</i></p>

3

Release the AC fans. Remove the mounting screws:

- M5x10 screws, bit Pz2, torque 3.5Nm [1 in figure below]
- M8x20 screws, bit HOP6, torque 20Nm [2 in figure below]

Pull out the fans.

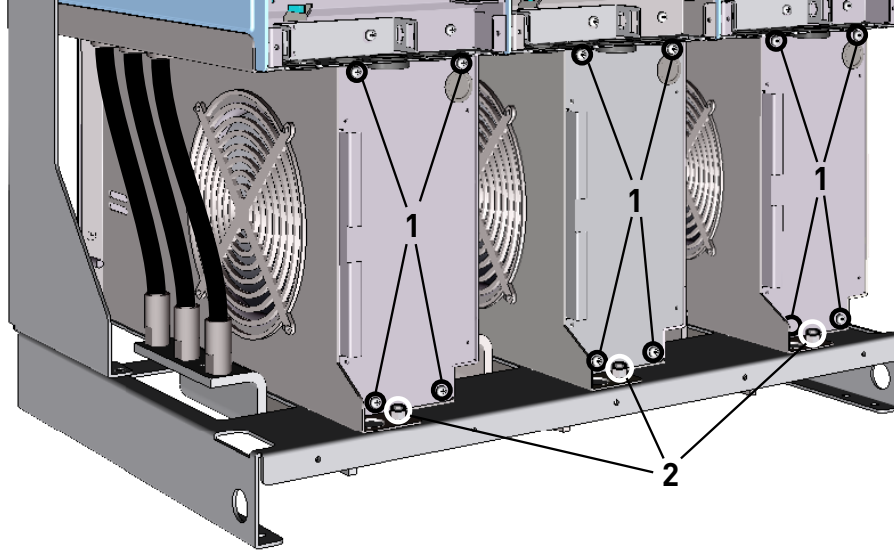

Figure 8.5. Removing the AC fans

4

Disconnect the two fan inverter cables (1) from the connector holders and the two DC wires (2) from the fuse base.

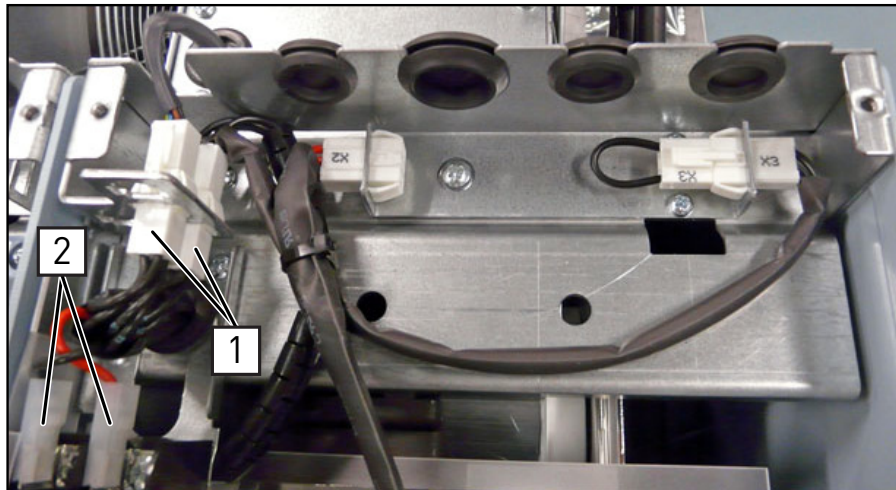

Figure 8.6. Fan inverter wiring

5

Cut off the cable ties holding the fan inverter cables to the frame and pull the cables and grommets out through the lead-in holes.

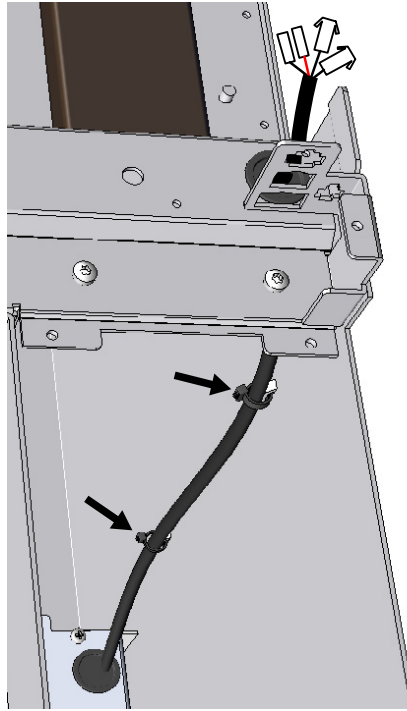

Figure 8.7. Fan inverter cable routing

6

Remove the M5x10 mounting screws. Use bit Pz2 and torque 3.5Nm. Take out the fan inverter assemblies.

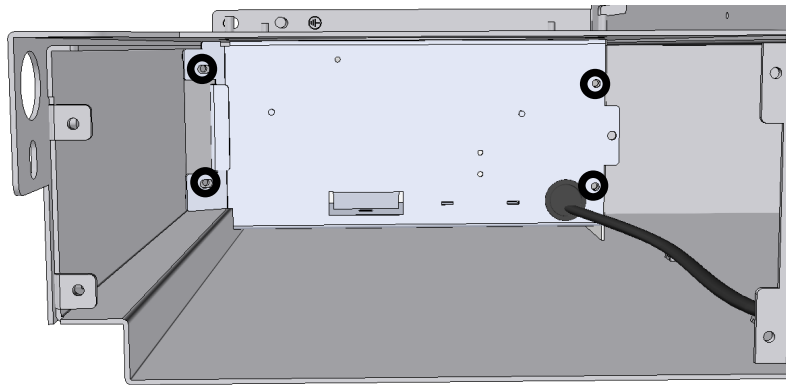

Figure 8.8. Removing the fan inverter assemblies

8.2.2 INSTRUCTIONS FOR FR13 AND FR14

FR13 and FR14 consist of FI13 and NFE units.

- Instructions for FI13, see Chapter 8.2.1
- Instructions for NFE, see Chapter 3.2.3

Remove the FR13 wire harness from between the FI13 and NFE units.

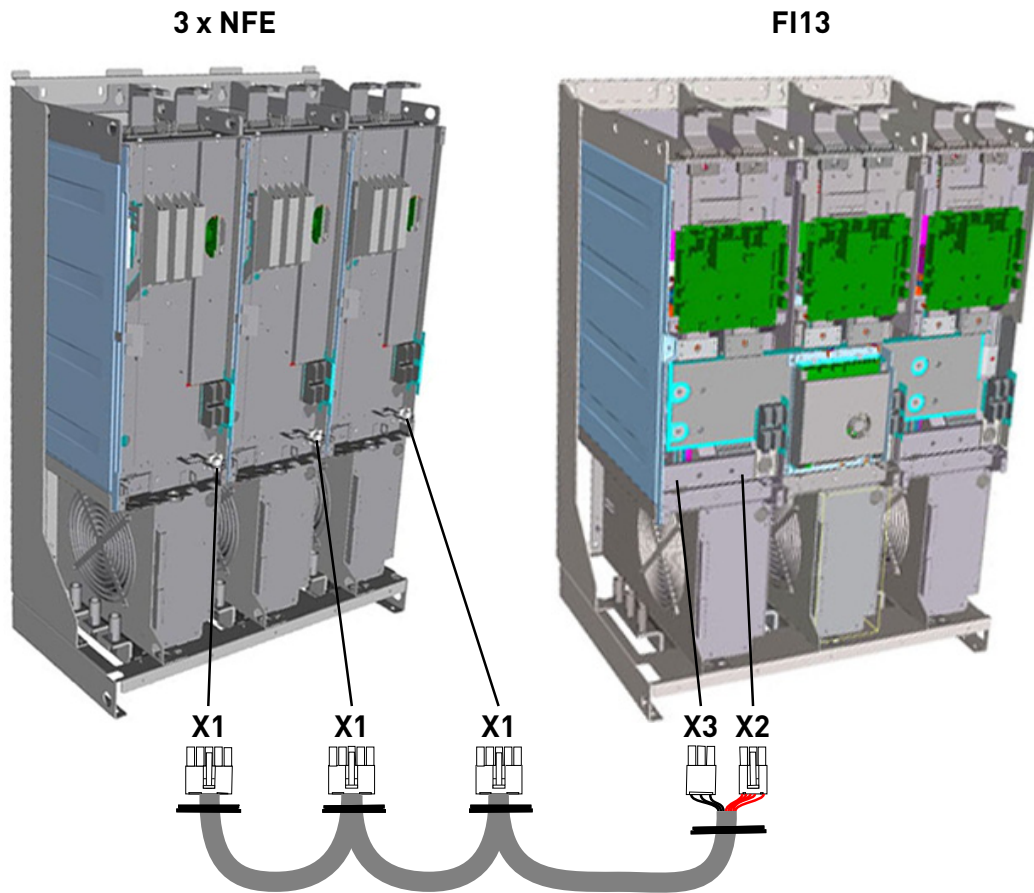

Figure 8.9. FR13 wire harness

8.3 DC FAN AND DC POWER SUPPLY INSTALLATION

Once the AC fans and other old parts have been removed (see Chapter 8.2), install the new DC fans and DC power supplies.

8.3.1 INSTRUCTIONS FOR FI13 AND FI14

NOTE! The following instructions apply to both FI13 and FI14, since FI14 consists of two FI13 units.

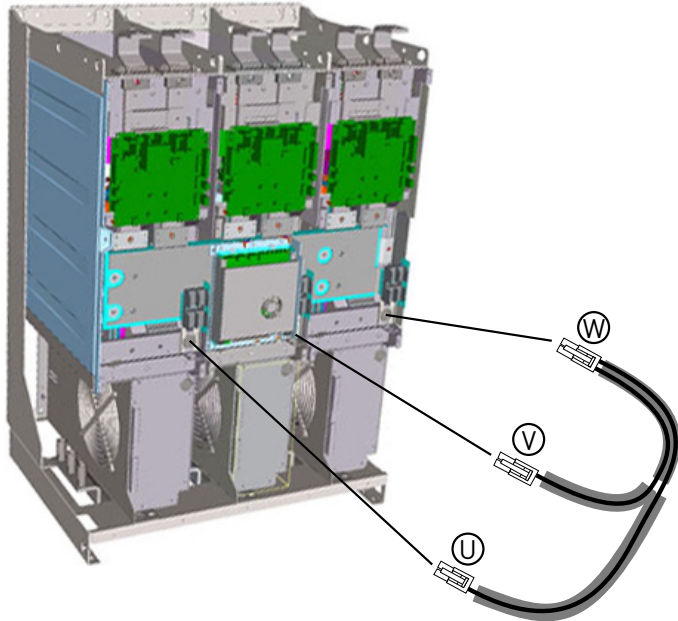
1	Install the three DC power supply assemblies. The assemblies are mounted in the same way as the old fan inverter assemblies. Use the M5x10 mounting screws (MC00046) supplied in the retrofit kit. See Figure 8.8 on page 54.
2	Use the cable ties (MC00178) supplied in the retrofit kit to attach the power supply cables to the frame. See Figure 8.7 on page 54.
3	Connect the fan power supply wires to the connector holder and fuse base as shown in Figure 8.6 on page 53.
4	Install the three DC fans. The fans are mounted in the same way as the old AC fans. Use the M5x10 mounting screws (MC00046) supplied in the retrofit kit. See Figure 8.5 on page 53. NOTE! Do not forget to re-attach the three M8x20 screws on the frame.
5	Connect the three fan supply wires. See Figure 8.4 on page 52.
6	<p>Connect the DC minus chaining wire set (70CPE05207) provided in the retrofit kit between the DC power supply DC minus connectors.</p> <p>NOTE! Notice the phase markings (U, V, W) on the DC minus chaining wire connectors and make sure they are connected to the right phases.</p>  <p style="text-align: center;"><i>Figure 8.10. DC minus chaining wire set connection</i></p>
7	Check that the power supplies and DC fans function. See the testing instructions in Chapter 9.
8	If the fans and power supplies work properly, re-attach the covers. See Figure 8.3 on page 52.
9	Attach the 'Product modified'-sticker (70CPL00062) supplied in the retrofit kit in a visible place on the front side of the drive. On the sticker, write "DC fan retrofit" and the installation date. In FI14, place a sticker on both units.

8.3.2 INSTRUCTIONS FOR FR13 AND FR14

FR13 and FR14 consist of FI13 and NFE units.

- Instructions for FI13, see Chapter 8.3.1
- Instructions for NFE, see Chapter 3.3.3

Connect the FR13 wire harness supplied in the retrofit kit (PP13100, PP13101 or PP13108) between the FI13 and NFE units. The harness is connected as shown in Figure 8.9 on page 55, except the new wire harness has an additional DC- wire, which needs to be connected on the FI13 fuse base (see 1 in figure below).

Use two cable ties (MC00178, see 2 in figure below) supplied in the retrofit kit to tie the DC- wire on the FI13 wire harness.

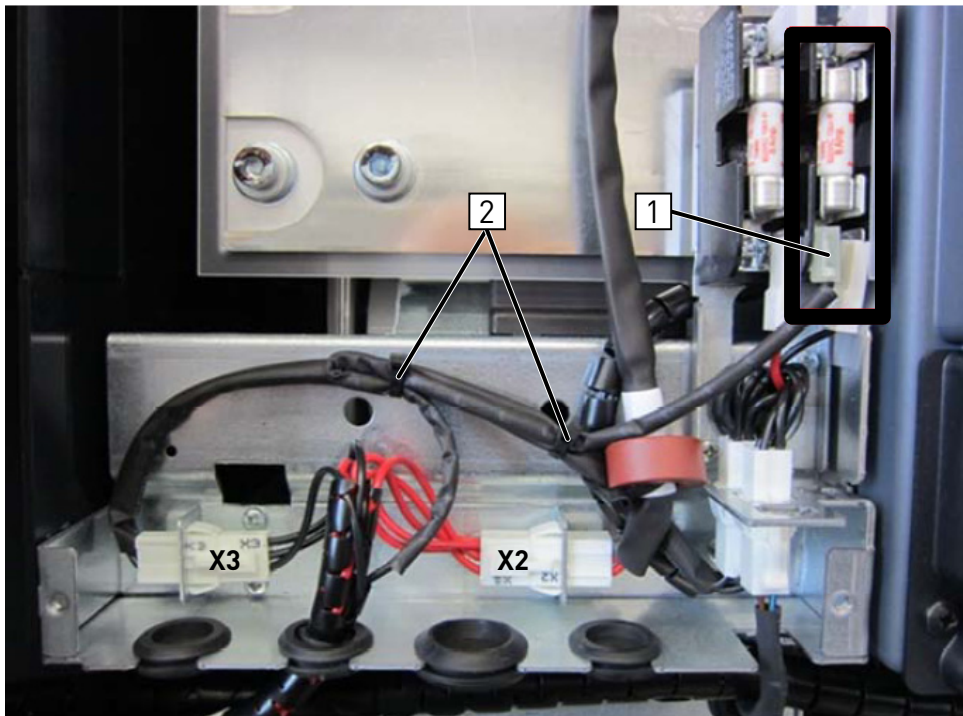

Figure 8.11. FR13 wire harness additional DC- wire

9. TESTING THE DC FAN AND POWER SUPPLY

- Power up the fan power supply with an external DC power supply through connector X2. Connect the DC- to pin 1 and DC+ to pin 3. Use nominal voltage and a 1A current limit. **NOTE!** In drives with more than one fan and power supply, power up and test the supplies one at a time.
- Check that the power supply and fan are running. See the three LED's on the fan power supply. The LED's are explained in the table below.
- If the power supply and fan are working properly, turn off the external power supply and re-assemble the drive according to the instructions given in previous chapters.

Table 9.1. LED's on the fan power supply

Color	Component	Meaning
Green	H6	Power ON
Yellow	H8	Fan control enable
Red	H9	Alarm, if minimum rotation speed is not reached

- If the fan power supply does not run, check that the fan power supply fuses are not burned.
- If the fuses are OK, measure the resistance from fan power supply board connector X2 (Figure 9.1), between pin 1 (DC-) and pin 3 (DC+). If the pins are in short circuit, the board is broken and needs to be replaced.

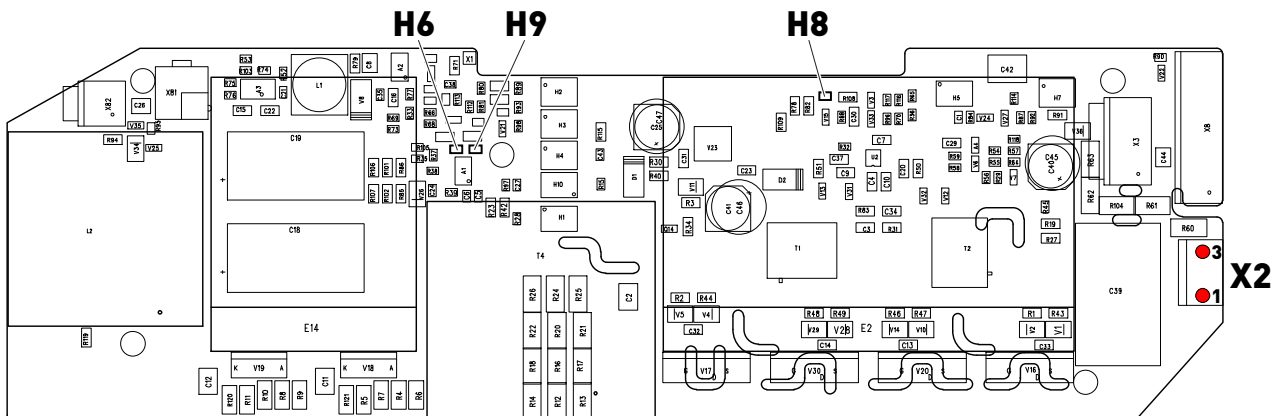

Figure 9.1. Fan power supply top side layout

Document ID:



Rev. V002