

**VACON<sup>®</sup> 100 X**  
AC DRIVES

**INSTALLATION MANUAL**

**VACON<sup>®</sup>**



**INDEX**

Document code (Original Instructions): DPD00534L

Revision release date: 5.2.2021

|   |           |
|---|-----------|
| <b>1. Safety</b> .....  | <b>6</b>  |
| 1.1 Signs.....  | 6         |
| 1.2 Units.....  | 6         |
| 1.3 Danger.....   | 7         |
| 1.4 Warnings.....   | 7         |
| 1.5 Grounding and earth fault protection.....                         | 9         |
| 1.6 Insulation system.....  | 12        |
| 1.7 Compatibility with RCDs.....                                      | 13        |
| 1.8 Extended temperature range.....                                   | 13        |
| 1.9 Electro-magnetic compatibility (EMC).....                         | 13        |
| 1.10 Marine environment.....  | 14        |
| <b>2. Receiving the delivery</b> .....                                | <b>15</b> |
| 2.1 Type designation code.....  | 16        |
| 2.2 order codes.....  | 17        |
| 2.3 Unpacking and lifting the AC drive.....                           | 18        |
| 2.4 Accessories.....  | 18        |
| 2.4.1 Enclosure MM4.....  | 18        |
| 2.4.2 Enclosure MM5.....  | 19        |
| 2.4.3 Enclosure MM6.....  | 19        |
| 2.4.4 STO terminal connector.....                                     | 20        |
| 2.4.5 'Product modified' sticker.....                                 | 20        |
| 2.4.6 Disposal.....   | 20        |
| <b>3. Mounting</b> .....  | <b>21</b> |
| 3.1 Dimensions MM4.....   | 21        |
| 3.2 Dimensions MM5.....   | 22        |
| 3.3 Dimensions MM6.....   | 23        |
| 3.4 Introduction of modules.....                                      | 24        |
| 3.5 Mounting.....   | 25        |
| 3.5.1 Wall-mounting.....  | 26        |
| 3.5.2 Motor-mounting.....   | 26        |
| 3.5.3 Segregated modules.....   | 26        |
| 3.6 Cooling.....  | 27        |
| <b>4. Power cabling</b> .....   | <b>28</b> |
| 4.1 Circuit breaker.....  | 30        |
| 4.2 UL standards on cabling.....                                      | 30        |
| 4.3 Description of the terminals.....                                 | 31        |
| 4.4 Cable dimensioning and selection.....                             | 34        |
| 4.4.1 Cable and fuse sizes, enclosures MM4 to MM6.....                | 34        |
| 4.4.2 Cable and fuse sizes, enclosures MM4 to MM6, North America..... | 35        |
| 4.4.3 Brake resistor cables.....                                      | 36        |
| 4.4.4 Control cables.....   | 36        |
| 4.5 Cable installation.....   | 37        |
| <b>5. Control unit</b> .....  | <b>45</b> |
| 5.1 Control unit cabling.....   | 46        |
| 5.1.1 Control cable sizing.....                                       | 46        |
| 5.1.2 Standard I/O terminals.....                                     | 47        |
| 5.1.3 Relay and thermistor input terminals.....                       | 48        |
| 5.1.4 Safe Torque off (STO) terminals.....                            | 48        |
| 5.1.5 Selection of terminal functions with DIP switches.....          | 49        |
| 5.1.6 Isolating digital inputs from ground.....                       | 49        |

|           |  |            |
|-----------|--|------------|
| 5.1.7     | Bus termination of the RS485 connection .....        | 50         |
| 5.2       | I/O cabling and fieldbus connection .....            | 51         |
| 5.2.1     | Prepare for use through Ethernet .....               | 51         |
| 5.2.2     | Prepare for use through RS485 .....                  | 52         |
| 5.2.3     | RS485 cable data .....                               | 53         |
| 5.3       | Battery installation for Real Time Clock (RTC) ..... | 54         |
| <b>6.</b> | <b>Commissioning .....</b>                           | <b>57</b>  |
| 6.1       | Commissioning of the drive .....                     | 58         |
| 6.2       | Changing EMC protection class .....                  | 59         |
| 6.3       | Running the motor .....                              | 61         |
| 6.3.1     | Cable and motor insulation checks .....              | 61         |
| 6.3.2     | Motor overload protection .....                      | 61         |
| 6.4       | Maintenance .....                                    | 64         |
| <b>7.</b> | <b>Technical data .....</b>                          | <b>65</b>  |
| 7.1       | AC drive power ratings .....                         | 65         |
| 7.1.1     | Mains voltage 3AC 208-240V .....                     | 65         |
| 7.1.2     | Mains voltage 3AC 380-480/500V .....                 | 66         |
| 7.1.3     | Definitions of overloadability .....                 | 67         |
| 7.2       | Brake resistor ratings .....                         | 68         |
| 7.3       | VACON® 100 X - technical data .....                  | 69         |
| 7.3.1     | Technical information on control connections .....   | 72         |
| <b>8.</b> | <b>Options .....</b>                                 | <b>74</b>  |
| 8.1       | Mains switch .....                                   | 74         |
| 8.1.1     | Installation .....                                   | 75         |
| 8.2       | Control Keypad .....                                 | 79         |
| 8.2.1     | Mounting onto the drive .....                        | 79         |
| 8.2.2     | Installation .....                                   | 80         |
| 8.2.3     | Wall-mounting .....                                  | 82         |
| 8.2.4     | Graphical and Text keypad .....                      | 85         |
| 8.2.5     | VACON® keypad with graphical display .....           | 86         |
| 8.2.6     | VACON® keypad with text segment display .....        | 93         |
| 8.2.7     | Fault Tracing .....                                  | 97         |
| 8.3       | Heater (arctic option) .....                         | 106        |
| 8.3.1     | Safety .....   | 106        |
| 8.3.2     | Dangers .....  | 106        |
| 8.3.3     | Technical data .....                                 | 106        |
| 8.3.4     | Fuses .....  | 107        |
| 8.3.5     | Mounting instructions: MM4 Example .....             | 107        |
| 8.4       | Option boards .....                                  | 110        |
| 8.5       | Flange adapter .....                                 | 111        |
| 8.5.1     | Mounting instructions: MM4 Example .....             | 114        |
| <b>9.</b> | <b>Safe Torque Off .....</b>                         | <b>116</b> |
| 9.1       | General description .....                            | 116        |
| 9.2       | Warnings .....                                       | 116        |
| 9.3       | Standards .....                                      | 117        |
| 9.4       | The principle of STO .....                           | 118        |
| 9.4.1     | Technical details .....                              | 119        |
| 9.5       | Connections .....                                    | 119        |
| 9.5.1     | Safety Capability Cat. 4 / PL e / SIL 3 .....        | 120        |
| 9.5.2     | Safety Capability Cat. 3 / PL e / SIL 3 .....        | 122        |
| 9.5.3     | Safety Capability Cat. 2 / PL d / SIL 2 .....        | 123        |
| 9.5.4     | Safety Capability Cat. 1 / PL c / SIL 1 .....        | 124        |
| 9.6       | Commissioning .....                                  | 125        |
| 9.6.1     | General wiring instructions .....                    | 125        |

|   |     |
|---|-----|
| 9.6.2 Checklist for commissioning ..... | 126 |
| 9.7 Parameters and fault tracing .....  | 127 |
| 9.8 Maintenance and diagnostics .....   | 127 |

# 1. SAFETY

This manual contains clearly marked warning information which is intended for your personal safety and to avoid any unintentional damage to the product or connected appliances.

**Please read the warning information carefully.**



**VACON® 100 X is a drive designed to control asynchronous AC motors and permanent magnet motors. The product is intended to be installed in a restricted access location and for a general purpose use.**

**Only trained and qualified personnel authorized by the manufacturer are allowed to install, operate and maintain the drive.**

## 1.1 SIGNS

The cautions and warnings are marked as follows:

Table 1. Warning signs.

|   |                      |
|---|----------------------|
|    | = DANGEROUS VOLTAGE! |
|   | = HOT SURFACE        |
|  | = WARNING or CAUTION |

## 1.2 UNITS

The dimensions used in this manual conform to International Metric System units, otherwise known as SI (Système International d’Unités) units. For the purpose of the equipment’s UL certification, some of these dimensions are accompanied by their imperial equivalents.

Table 2. Unit conversion table.

| Physical dimension | SI value            | US value     | Conversion factor  | US designation        |
|--------------------|---------------------|--------------|--------------------|-----------------------|
| length             | 1 mm                | 0.0394 inch  | 25.4               | inch                  |
| Weight             | 1 kg                | 2.205 lb     | 0.4536             | pound                 |
| Speed              | 1 min <sup>-1</sup> | 1 rpm        | 1                  | revolution per minute |
| Temperature        | 1 °C (T1)           | 33.8 °F (T2) | T2 = T1 x 9/5 + 32 | Fahrenheit            |
| Torque             | 1 Nm                | 8.851 lbf in | 0.113              | pound-force inches    |
| Power              | 1 kW                | 1.341 HP     | 0.7457             | horsepower            |

### 1.3 DANGER



The **components of the power unit of VACON<sup>®</sup> 100 X drives are live** when the drive is connected to mains potential. Coming into contact with this voltage is **extremely dangerous** and may cause death or severe injury.



The **motor terminals (U, V, W), the brake resistor terminals and the DC-terminals are live** when VACON<sup>®</sup> 100 X Drive is connected to the mains, even if the motor is not running.



**After disconnecting** the AC drive from the mains, **wait** until the indicators on the keypad go out (if no keypad is connected, see the indicators on the cover). Wait an additional 30 seconds before doing any work on the connections of VACON<sup>®</sup> 100 X Drive. Do not open the unit before this time has expired. After expiration of this time, use measuring equipment to absolutely ensure that no voltage is present. **Always ensure absence of voltage before starting any electrical work!**



The control I/O-terminals are isolated from the mains potential. However, the **relay outputs and other I/O-terminals may have a dangerous control voltage** present even when VACON<sup>®</sup> 100 X drive is disconnected from the mains.



**Before connecting** the AC drive to mains make sure that the powerhead of VACON<sup>®</sup> 100 X Drive is mounted firmly on the terminal box.



During a coast stop (see the Application Manual), the motor is still generating voltage to the drive. Therefore, do not touch the components of the AC drive before the motor has completely stopped and wait until the indicators on the keypad go out (if no keypad is connected, see the indicators on the cover). Wait an additional 30 seconds before starting any work on the drive.



**The terminals are live** when the VACON<sup>®</sup>100X Drive is connected to a photovoltaic system. **Photovoltaic cells generate DC voltage even at low intensity of sunlight.**

### 1.4 WARNINGS



VACON<sup>®</sup> 100 X AC drive is meant for **fixed installations** (on the motor or on the wall) **only**.



**Only DVC A circuits (Decisive Voltage Class A, according to IEC 61800-5-1) are allowed to be connected to the control unit.** This advice aims to protect both the drive and the client-application. The manufacturer is not responsible for direct or consequential damages resulting from unsafe connections of external circuits to the drive. See paragraph 1.6 for more details.



**Do not perform any measurements** when the AC drive is connected to the mains.



The **touch current** of VACON<sup>®</sup> 100 X AC drives exceeds 3.5mA AC. According to standard EN61800-5-1, **a reinforced protective ground connection** must be ensured. See paragraph 1.5 for more details.



If the AC drive is used as a part of a machine, the **machine manufacturer is responsible** for providing the machine with a **supply disconnecting device** (EN 60204-1). See paragraph 4.1 for more details.



Only **spare parts** delivered by the manufacturer can be used.



At power-up or fault reset, **the motor will start immediately** if the start signal is active, (unless the pulse control for Start/Stop logic has been selected) and the STO inputs are ready to be used (normal operation). The I/O functionalities (including start inputs) may change if parameters, applications or software are changed. Disconnect, therefore, the motor if an unexpected start can cause danger. This is valid only if STO inputs are energized. For prevention on unexpected restart, use appropriate safety relay connected to the STO inputs.



The **motor starts automatically** after automatic fault reset if the autoreset function is activated. See the Application Manual for more detailed information. This is valid only if STO inputs are energized. For prevention on unexpected restart, use appropriate safety relay connected to the STO inputs.



**Before performing any measurement on the motor or on the motor cable**, disconnect the motor cable from the AC drive.



Do not perform any voltage withstand test on any part of VACON® 100 X. The tests must be performed according to a specific procedure. Ignoring this procedure may damage the product.



**Do not touch the components on the circuit boards**. Static voltage discharge may damage the components.



Check that the **EMC level** of the AC drive corresponds to the requirements of your supply network. See paragraph 6.2 for more details.



In a domestic environment, this product may cause radio interference in which case supplementary mitigation measures may be required.



Optional keypad is IP66/Type 4X outdoor rated. Strong exposure to direct sunlight or to heavy temperatures might cause the degradation of display LCD.



Do not remove the EMC screws in the solar pump application. IT (impedance-grounded) AC supply network is not allowed in the solar pump application.



If a service switch is used on the motor output, parameter P3.1.2.6 Motor Switch must be enabled. Otherwise turning the service switch on while the drive is modulating can cause damage to the equipment. Notice also that the parameter Motor Switch is designed for a service switch or similar, not for repeated daily use.



## 1.5 GROUNDING AND EARTH FAULT PROTECTION



### CAUTION!

---

The VACON® 100 X AC drive must always be earthed with a grounding conductor connected to the grounding terminal marked with .

See Table 16 and Table 17 for the required cross-section of phase conductor and protective grounding conductor (both made of copper).

Since the touch current exceeds 3.5 mA AC, according to EN61800-5-1, the MM4 and MM5 must have a fixed connection and provision of an **additional terminal for a second protective grounding conductor** of the same cross-sectional area as the original protective grounding conductor. MM6 must have a fixed installation and a cross-section of the protective grounding conductor of at least 10 mm<sup>2</sup> Cu.

On the terminal-box, **three screws** (for MM4 and MM5) and **two screws** (for MM6) are provided for ORIGINAL and MOTOR protective grounding conductors: the customer can choose the screw for each one.

The cross-sectional area of every protective grounding conductor which does not form a part of the supply cable or cable enclosure must, in any case, be not less than:

- 2.5 mm<sup>2</sup> if mechanical protection is provided or
- 4 mm<sup>2</sup> if mechanical protection is not provided. For cord-connected equipment, provisions must be made so that the protective grounding conductor in the cord is, in the case of failure of the strain-relief mechanism, the last conductor to be interrupted.

The power-head is earthed through metal aglets, located on the terminal-box, which fit into spring baskets on the powerhead. See Figure 1, Figure 2 and Figure 3 for the location of the screws (three for MM4 and MM5, two for MM6) and the metal aglets (one for MM4 and MM5, two for MM6). Please, pay attention not to damage or remove these aglets.

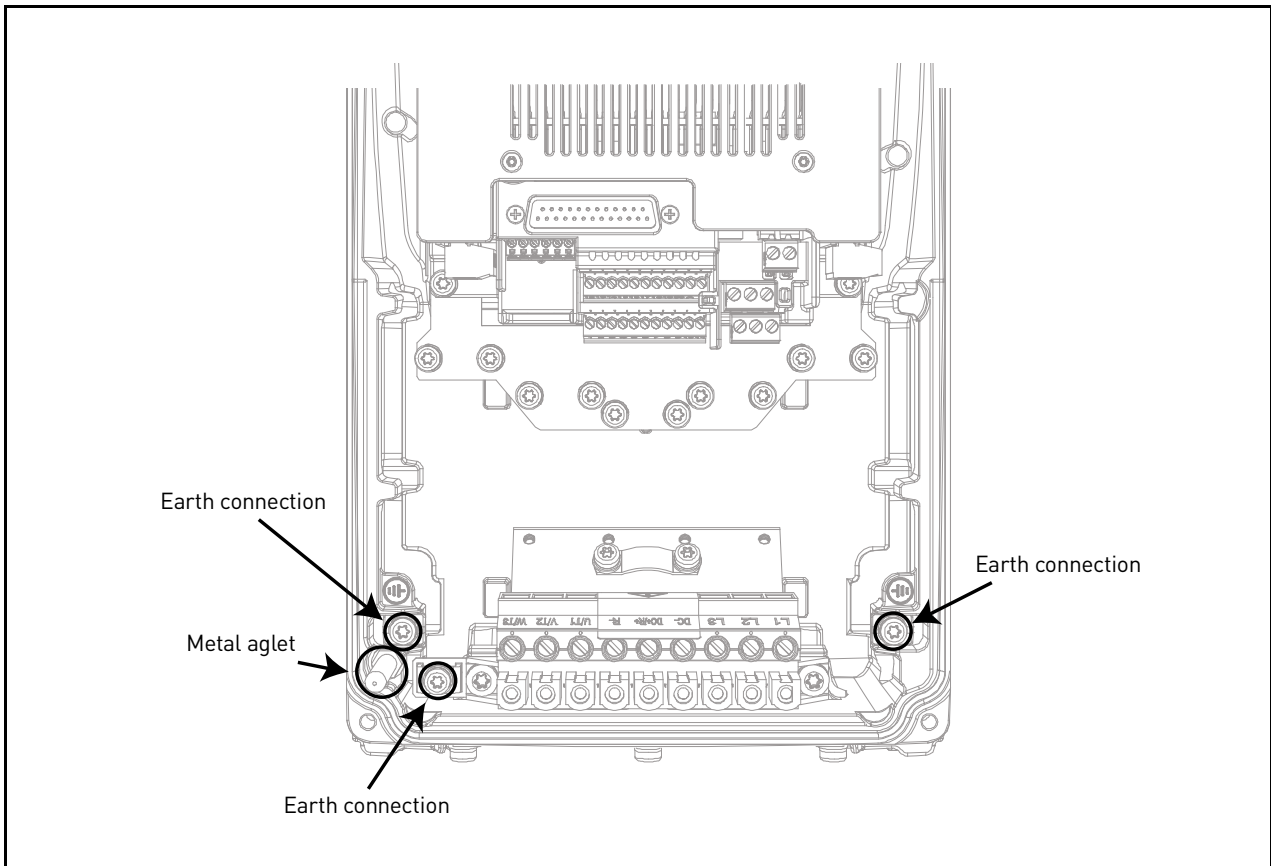

Figure 1. Earth connections and metal aglet in MM4

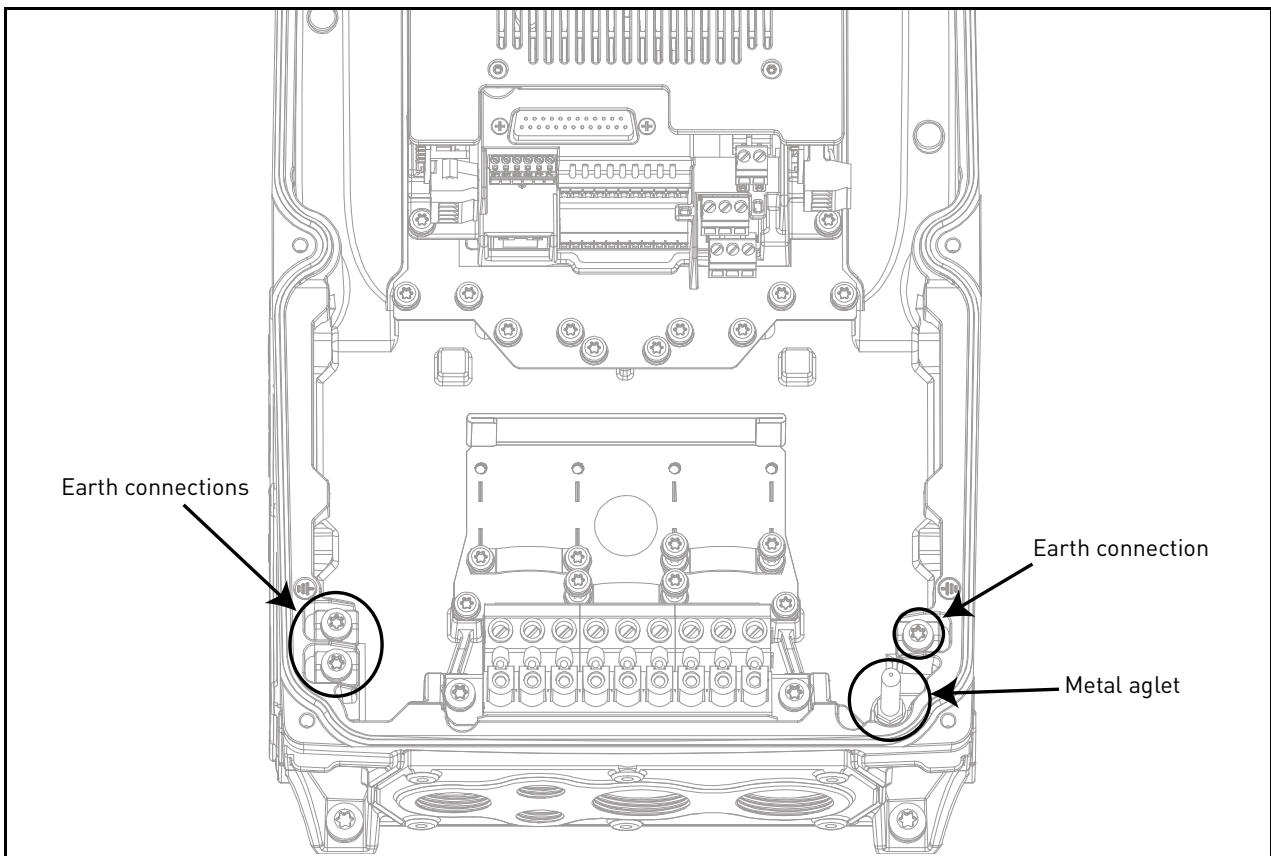

Figure 2. Earth connections and metal aglet in MM5

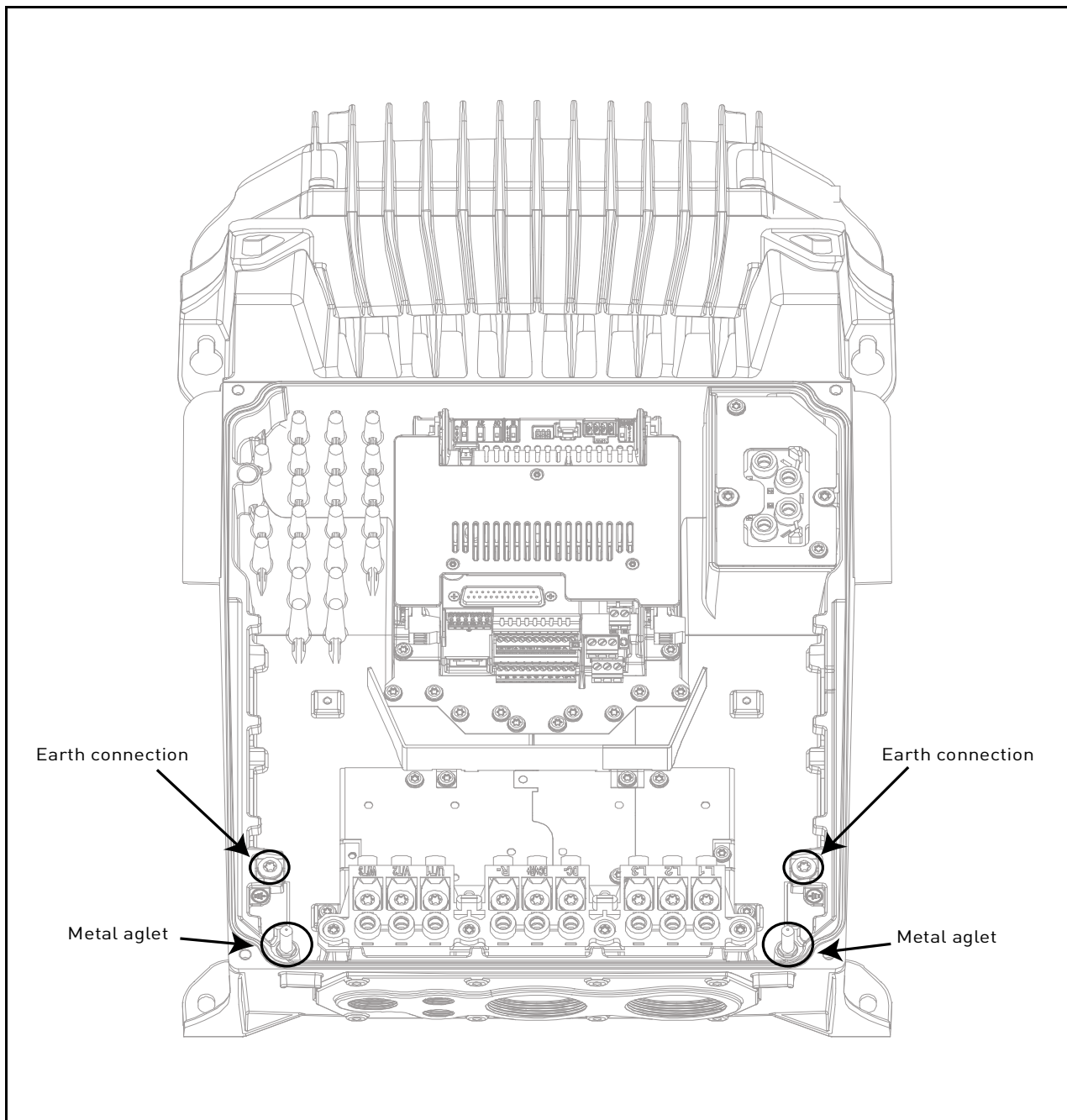

Figure 3. Earth connections and metal aglet in MM6

**However, always follow the local regulations for the minimum size of the protective grounding conductor.**

**NOTE:** Due to the high capacitive currents present in the AC drive, fault current protective switches may not function properly.

1.6 INSULATION SYSTEM



Please, consider carefully the insulation system depicted in Figure 4 before connecting any circuit to the unit.

A distinction has to be made for the following three groups of terminals, according the insulation system of VACON® 100 X:

- Mains and motor connections (L1, L2, L3, U, V, W)
- Relays (R01, R02)<sup>(\*)</sup>
- Thermistor-input
- Control terminals (I/Os, RS485, Ethernet, STO)

The Control terminals (I/Os, RS485, Ethernet, STO) are isolated from the Mains (the insulation is reinforced, according to IEC 61800-5-1) and **the GND terminals are referred to PE.**

This is important when you need to connect other circuits to the drive and test the complete assembly. Should you have any doubt or question, please contact your local distributor.

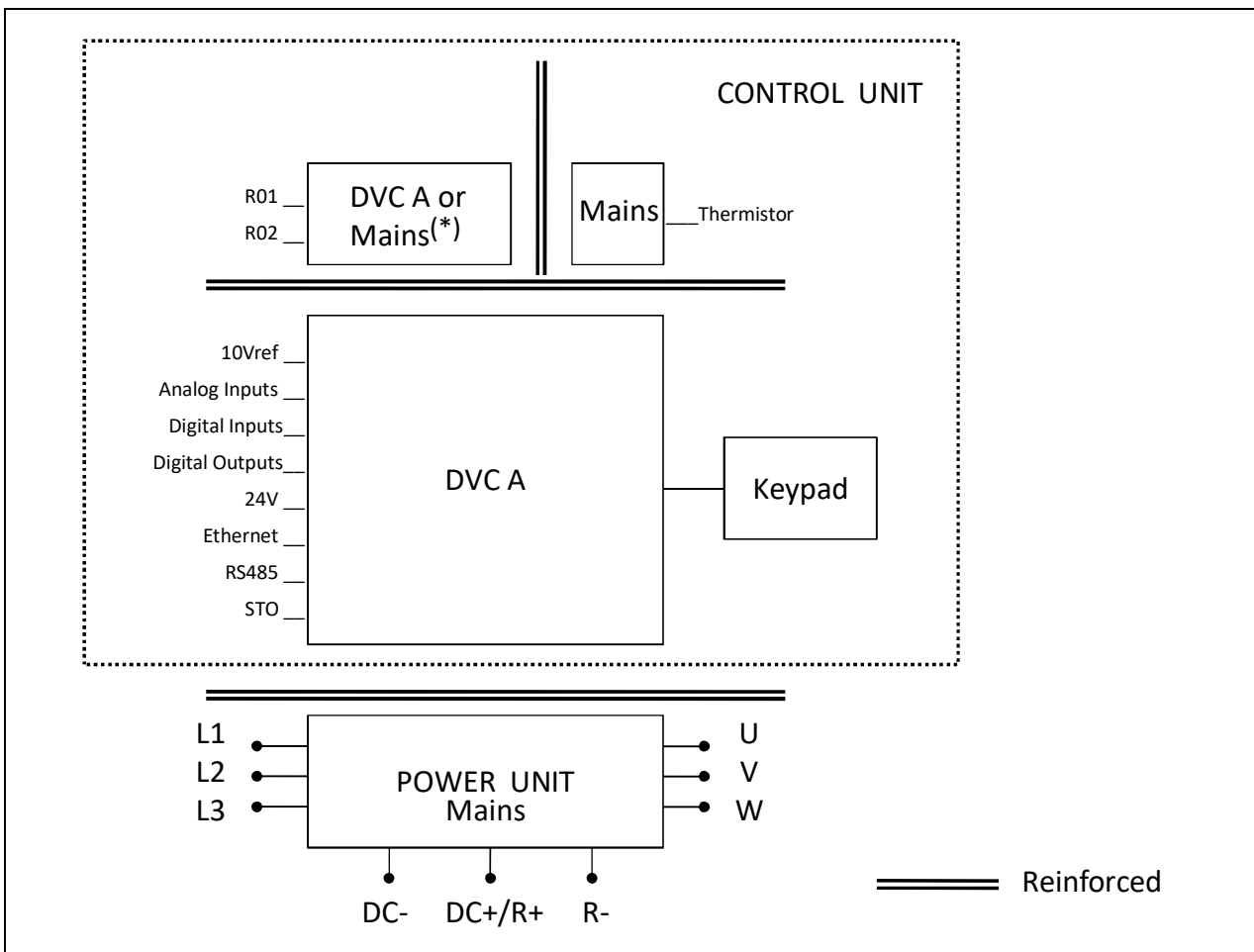

Figure 4. Insulation system



<sup>(\*)</sup> The relays may be used also with DVC A circuits. This is possible only if both relays are used with DVC A circuit: **to mix Mains and DVC A is not allowed.**

### 1.7 COMPATIBILITY WITH RCDs



This product can cause a d.c. current in the protective grounding conductor. Where a residual current-operated protective (RCD) or monitoring (RCM) device is used for protection in case of direct or indirect contact, only an RCD or RCM of **Type B** is allowed on the supply side of this product.

### 1.8 EXTENDED TEMPERATURE RANGE

VACON® 100 X has **an integrated cooling system**, independent from the motor fan. Under maximum operating conditions, the ambient temperature cannot exceed **40 °C**. See Table and Table 31 for the output rated current. Higher temperatures are allowed only with derating of the output current. With derating the unit can **operate up to 60°C**. See the Figure 5.

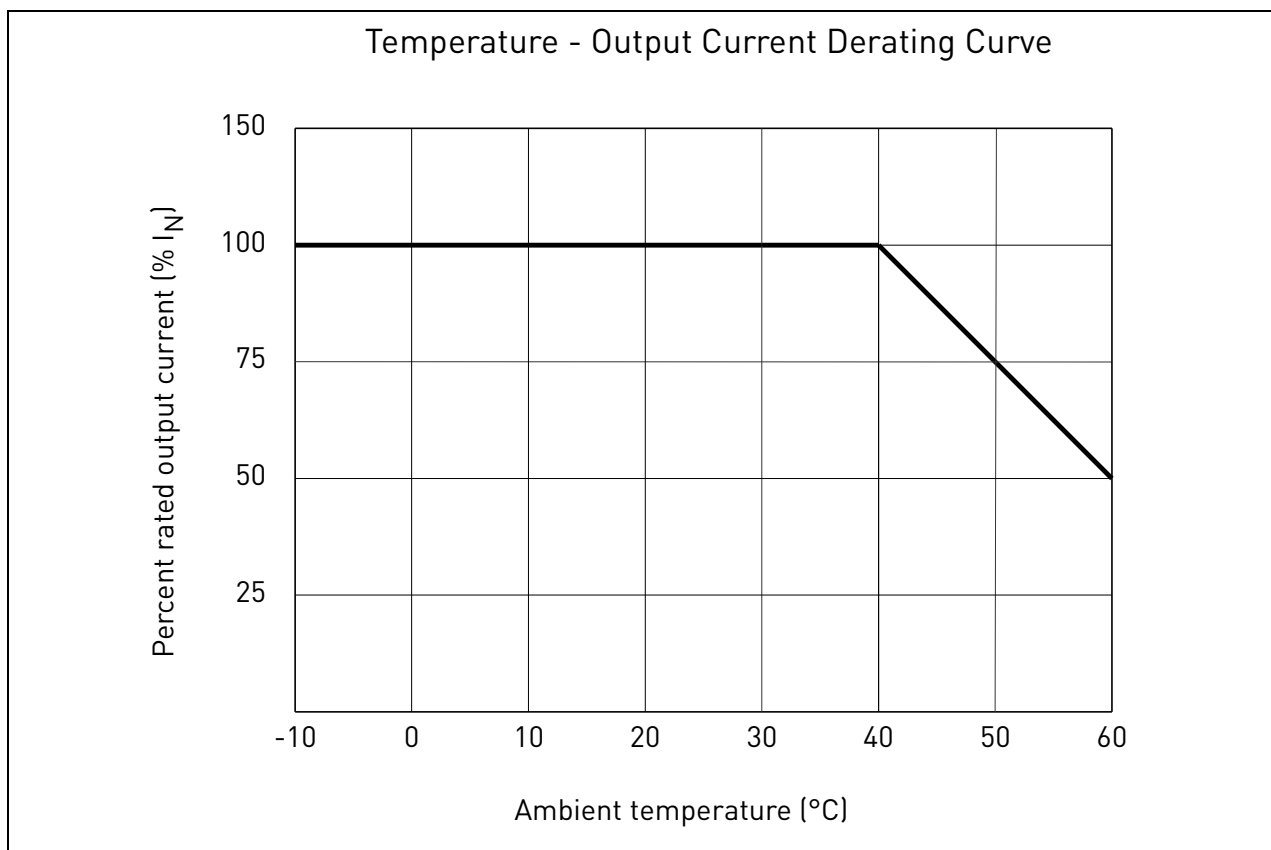

Figure 5. Temperature-output current derating curve

**NOTE:** the maximum allowed switching frequency above 50°C is 1.5 kHz.

The AC drive is cooled down by air-ventilation. Therefore, make sure that enough free space is left around the AC drive to ensure sufficient air circulation (see for more details the mounting instructions on chapter 3).

### 1.9 ELECTRO-MAGNETIC COMPATIBILITY (EMC)

The VACON® 100 X complies with IEC 61000-3-12, provided that the short circuit ratio ( $R_{SCE}$ ) is greater than or equal to 120 at the interface point between the user's supply and the public system. It is the responsibility of the installer or user of the equipment to ensure, by consultation with the distribution network operator if necessary, that the equipment is connected only to a supply with a short-circuit ratio  $R_{SCE}$  greater than or equal to 120.

### 1.10 MARINE ENVIRONMENT

For installation, safety and EMC requirements in a marine environment download and read the Marine Installation Guide.

**NOTE!** You can download the English and French product manuals with applicable safety, warning and caution information from <https://www.danfoss.com/en/service-and-support/>.

**REMARQUE** Vous pouvez télécharger les versions anglaise et française des manuels produit contenant l'ensemble des informations de sécurité, avertissements et mises en garde applicables sur le site <https://www.danfoss.com/en/service-and-support/>.

## 2. RECEIVING THE DELIVERY

Check the correctness of delivery by comparing your order data to the drive information found on the package label. If the delivery does not correspond to your order, contact the supplier immediately. See chapter 2.4.

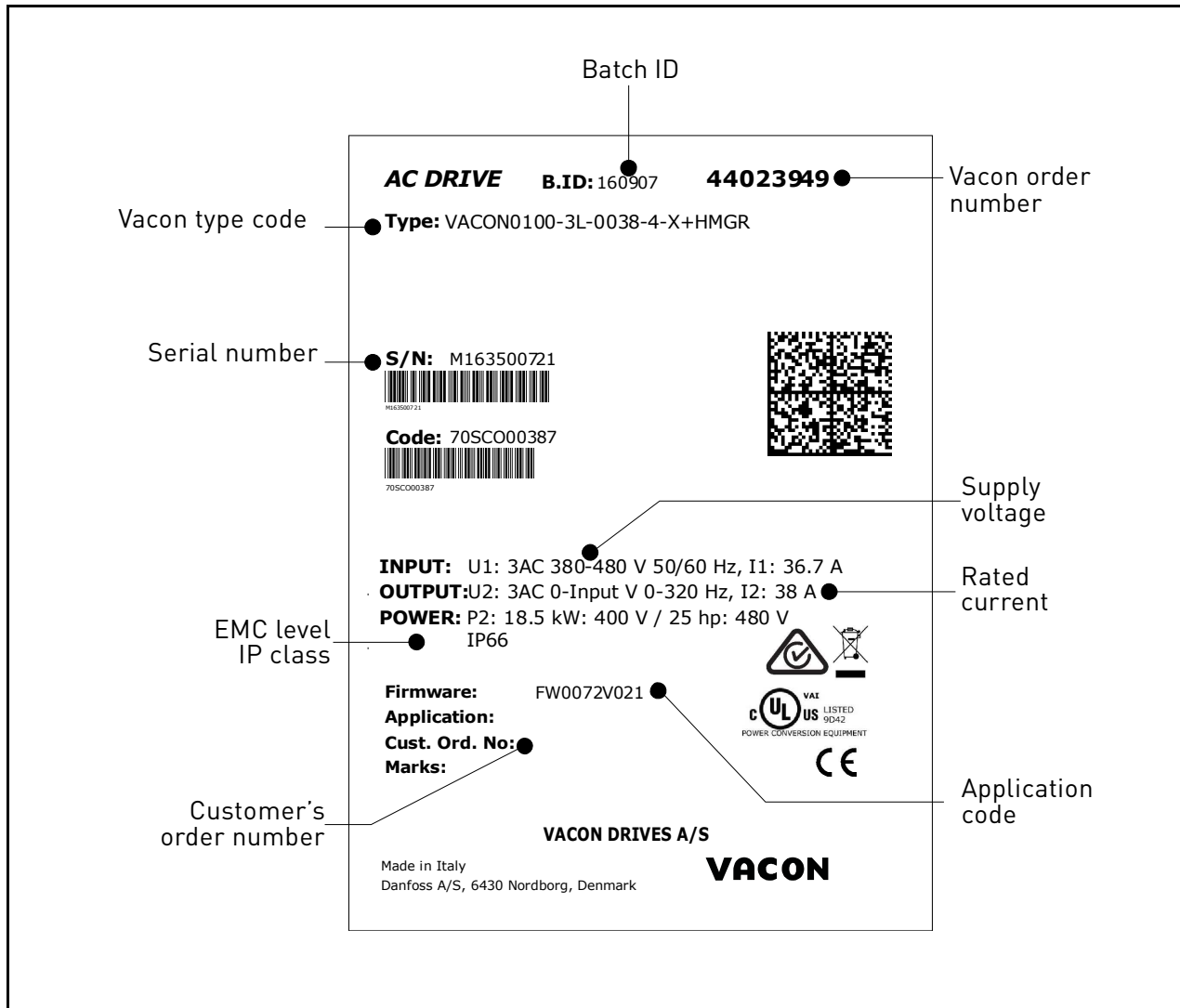

Figure 6. VACON® package label

## 2.1 TYPE DESIGNATION CODE

VACON® type designation code is formed of a nine-segment code and optional +codes. Each segment of the type designation code uniquely corresponds to the product and options you have ordered. The code is of the following format:

**VACON0100-3L-0061-4-X +xxxx +yyyy**

### VACON

This segment is common for all products.

### 0100

Product range:

0100 = VACON® 100 Product family

### 3L

Input/Function:

3L = Three-phase input

### 0061

Drive rating in ampere; e.g. 0061 = 61 A

See Table 30, Table 31 and Table 32 for all the drive ratings.

### 4

Supply voltage:

2 = 208-240 V

4 = 380-480 V

5 = 380-500 V

### X

-IP66/ Type 4X

-EMC-level C2

-Two relay outputs

-One thermistor input

-STO function

-GP software package installed

### R02

+EMC4

+LS60

+LSUS

+QGLC

### +xxxx +yyyy

Additional codes (Several options possible).

Examples of additional codes:

+HMGR

Graphical keypad IP66

+SRBT

Integrated battery for real time clock

+FBIE

Onboard fieldbus protocols activated (EtherNet/IP and PROFINET IO)

+A1181

Solar pump application



## 2.2 ORDER CODES

The order codes for VACON® 100 X drive family are shown in the following table:

Table 3. Order codes of VACON® 100 X. See chapter 7 for more details.

| Enclosure size                     | Order code            | Description             |
|------------------------------------|-----------------------|-------------------------|
| <b>Supply voltage 3AC 208-240V</b> |                       |                         |
| <b>MM4</b>                         | VACON0100-3L-0006-2-X | 1.1 kW - 1.5 HP drive   |
|                                    | VACON0100-3L-0008-2-X | 1.5 kW - 2.0 HP drive   |
|                                    | VACON0100-3L-0011-2-X | 2.2 kW - 3.0 HP drive   |
|                                    | VACON0100-3L-0012-2-X | 3.0 kW - 4.0 HP drive   |
| <b>MM5</b>                         | VACON0100-3L-0018-2-X | 4.0 kW - 5.0 HP drive   |
|                                    | VACON0100-3L-0024-2-X | 5.5 kW - 7.5 HP drive   |
|                                    | VACON0100-3L-0031-2-X | 7.5 kW - 10.0 HP drive  |
| <b>MM6</b>                         | VACON0100-3L-0048-2-X | 11.0 kW - 15.0 HP drive |
|                                    | VACON0100-3L-0062-2-X | 15.0 kW - 20.0 HP drive |
| <b>Supply voltage 3AC 380-480V</b> |                       |                         |
| <b>MM4</b>                         | VACON0100-3L-0003-4-X | 1.1 kW - 1.5 HP drive   |
|                                    | VACON0100-3L-0004-4-X | 1.5 kW - 2.0 HP drive   |
|                                    | VACON0100-3L-0005-4-X | 2.2 kW - 3.0 HP drive   |
|                                    | VACON0100-3L-0008-4-X | 3.0 kW - 4.0 HP drive   |
|                                    | VACON0100-3L-0009-4-X | 4.0 kW - 5.0 HP drive   |
|                                    | VACON0100-3L-0012-4-X | 5.5 kW - 7.5 HP drive   |
| <b>MM5</b>                         | VACON0100-3L-0016-4-X | 7.5 kW - 10.0 HP drive  |
|                                    | VACON0100-3L-0023-4-X | 11.0 kW - 15.0 HP drive |
|                                    | VACON0100-3L-0031-4-X | 15.0 kW - 20.0 HP drive |
| <b>MM6</b>                         | VACON0100-3L-0038-4-X | 18.5 kW - 25.0 HP drive |
|                                    | VACON0100-3L-0046-4-X | 22.0 kW - 30.0 HP drive |
|                                    | VACON0100-3L-0061-4-X | 30.0 kW - 40.0 HP drive |
|                                    | VACON0100-3L-0072-4-X | 37.0 kW - 50.0 HP drive |
| <b>Supply voltage 3AC 380-500V</b> |                       |                         |
| <b>MM4</b>                         | VACON0100-3L-0003-5-X | 1.1 kW - 1.5 HP drive   |
|                                    | VACON0100-3L-0004-5-X | 1.5 kW - 2.0 HP drive   |
|                                    | VACON0100-3L-0005-5-X | 2.2 kW - 3.0 HP drive   |
|                                    | VACON0100-3L-0008-5-X | 3.0 kW - 4.0 HP drive   |
|                                    | VACON0100-3L-0009-5-X | 4.0 kW - 5.0 HP drive   |
|                                    | VACON0100-3L-0012-5-X | 5.5 kW - 7.5 HP drive   |
| <b>MM5</b>                         | VACON0100-3L-0016-5-X | 7.5 kW - 10.0 HP drive  |
|                                    | VACON0100-3L-0023-5-X | 11.0 kW - 15.0 HP drive |
|                                    | VACON0100-3L-0031-5-X | 15.0 kW - 20.0 HP drive |
| <b>MM6</b>                         | VACON0100-3L-0038-5-X | 18.5 kW - 25.0 HP drive |
|                                    | VACON0100-3L-0046-5-X | 22.0 kW - 30.0 HP drive |
|                                    | VACON0100-3L-0061-5-X | 30.0 kW - 40.0 HP drive |
|                                    | VACON0100-3L-0072-5-X | 37.0 kW - 50.0 HP drive |

### 2.3 UNPACKING AND LIFTING THE AC DRIVE

The weights of the AC drives vary according to enclosure size. You may need to use a piece of special lifting equipment to move the drive from its package. Note the weights of each individual enclosure size in Table below.

Table 4. Enclosure weights.

| Enclosure size | Weight |      |
|----------------|--------|------|
|                | [kg]   | [lb] |
| MM4            | 8.8    | 19.4 |
| MM5            | 14.9   | 32.8 |
| MM6            | 31.5   | 69.4 |

VACON® 100 X drives have undergone scrupulous tests and quality checks at the factory before they are delivered to the customer. However, after unpacking the product, check that no signs of transport damage are to be found on the product and that the delivery is complete.

Should the drive have been damaged during shipping, please contact the cargo insurance company or the carrier in the first instance.

### 2.4 ACCESSORIES

After having opened the transport package and lifted the drive out, check immediately that these various accessories were included in the delivery. The contents of the accessories bag differ by drive size:

#### 2.4.1 ENCLOSURE MM4

Table 5. Content of accessory bag, MM4.

| Item                                   | Quantity | Purpose  |
|--|----------|--|
| STO terminal connector                 | 1        | Six pin black connector (see Figure 7) to use STO function |
| M4 x 12 DIN6900-3-Combi-Delta-Tx screw | 10       | Screws for control cable clamps                            |
| M1-3 Cable clamp                       | 5        | Clamping control cables                                    |
| M4 x 12 DIN6900-3-Combi-Delta-Tx screw | 6        | Screws for power cable clamps                              |
| M25 Cable clamp                        | 3        | Clamping power cables                                      |
| 'Product modified' sticker             | 1        | Information about modifications                            |
| HMI cap*                               | 1        | Closing cap for the HMI connector                          |

\*. Provided only if the drive is delivered with the keypad.

## 2.4.2 ENCLOSURE MM5

Table 6. Content of accessory bag, MM5.

| Item                                   | Quantity | Purpose  |
|--|----------|--|
| STO terminal connector                 | 1        | Six pin black connector (see Figure 7) to use STO function |
| M4 x 12 DIN6900-3-Combi-Delta-Tx screw | 10       | Screws for control cable clamps                            |
| M1-3 Cable clamp                       | 5        | Clamping control cables                                    |
| M4 x 12 DIN6900-3-Combi-Delta-Tx screw | 6        | Screws for power cable clamps                              |
| M32 Cable clamp                        | 3        | Clamping power cables                                      |
| 'Product modified' sticker             | 1        | Information about modifications                            |
| HMI cap*                               | 1        | Closing cap for the HMI connector                          |

\*. Provided only if the drive is delivered with the keypad.

## 2.4.3 ENCLOSURE MM6

Table 7. Content of accessory bag, MM6.

| Item                                   | Quantity | Purpose  |
|--|----------|--|
| STO terminal connector                 | 1        | Six pin black connector (see Figure 7) to use STO function |
| M4 x 12 DIN6900-3-Combi-Delta-Tx screw | 10       | Screws for control cable clamps                            |
| M1-3 Cable clamp                       | 5        | Clamping control cables                                    |
| M4 x 25 DIN6900-3-Combi-Delta-Tx screw | 6        | Screws for power cable clamps                              |
| M40 Cable clamp                        | 3        | Clamping power cables                                      |
| 'Product modified' sticker             | 1        | Information about modifications                            |
| HMI cap*                               | 1        | Closing cap for the HMI connector                          |

\*. Provided only if the drive is delivered with the keypad mounted.

2.4.4 ST0 TERMINAL CONNECTOR

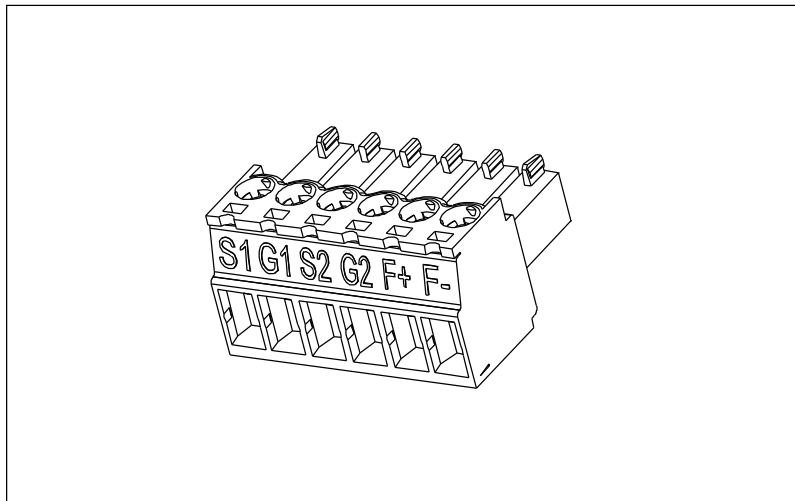

Figure 7. ST0 connector

2.4.5 ‘PRODUCT MODIFIED’ STICKER

In the small plastic bag included in the delivery you will find a silver *Product modified* sticker. The purpose of the sticker is to notify the service personnel about the modifications made in the AC drive. Attach the sticker on the side of the AC drive to avoid losing it. Should the AC drive be later modified, mark the change on the sticker.

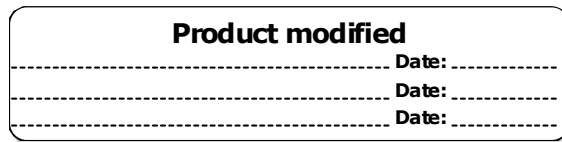

Figure 8. 'Product modified' sticker

2.4.6 DISPOSAL

|  |  |
|--|--|
|  | <p>When the device reaches the end of its operating life do not dispose of it as a part of standard household garbage. Main components of the product can be recycled, but some need to be fragmented to separate different types of materials and components that need to be treated as special waste from electrical and electronic components. To ensure environmentally sound and safe recycling treatment, the product can be taken to appropriate recycling center or returned to the manufacturer. Observe local and other applicable laws as they may mandate special treatment for specific components or special treatment may be ecologically sensible.</p> |
|--|--|

### 3. MOUNTING

VACON® 100 X is the ideal solution for a decentralised installation. It is conceived to be mounted on a wall or directly on the motor, saving space and reducing the cabling complexity. In both cases, it must be ensured that the mounting plane is even.

#### 3.1 DIMENSIONS MM4

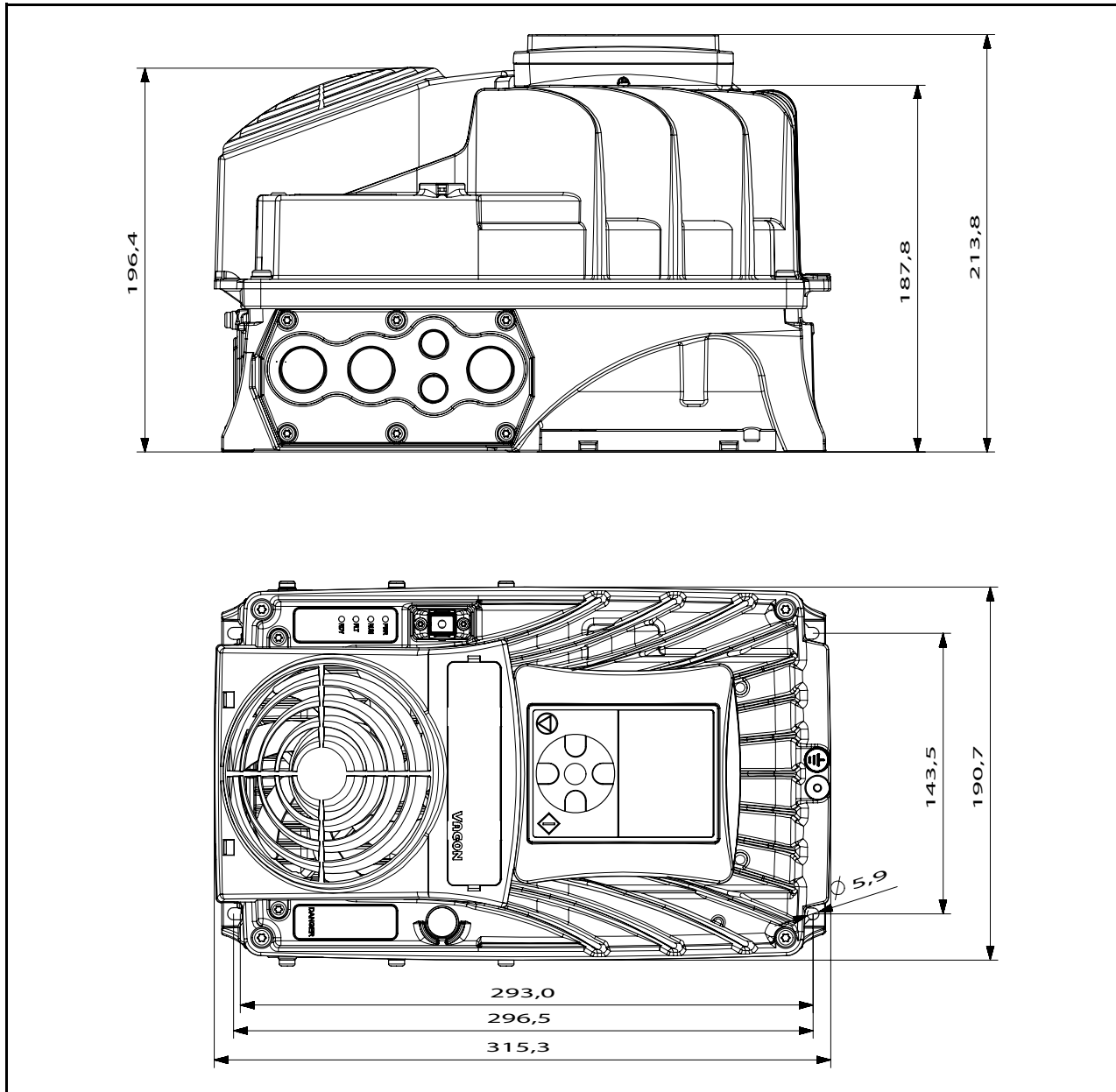

Figure 9. VACON® 100 X drive dimensions, MM4

| Enclosure size | Dimensions W x H x D  |                     |
|----------------|-----------------------|---------------------|
|                | [mm]                  | [in]                |
| MM4            | 190.7 x 315.3 x 196.4 | 7.51 x 12.41 x 7.73 |
| MM4 +HMGR      | 190.7 x 315.3 x 213.8 | 7.51 x 12.41 x 8.42 |

3.2 DIMENSIONS MM5

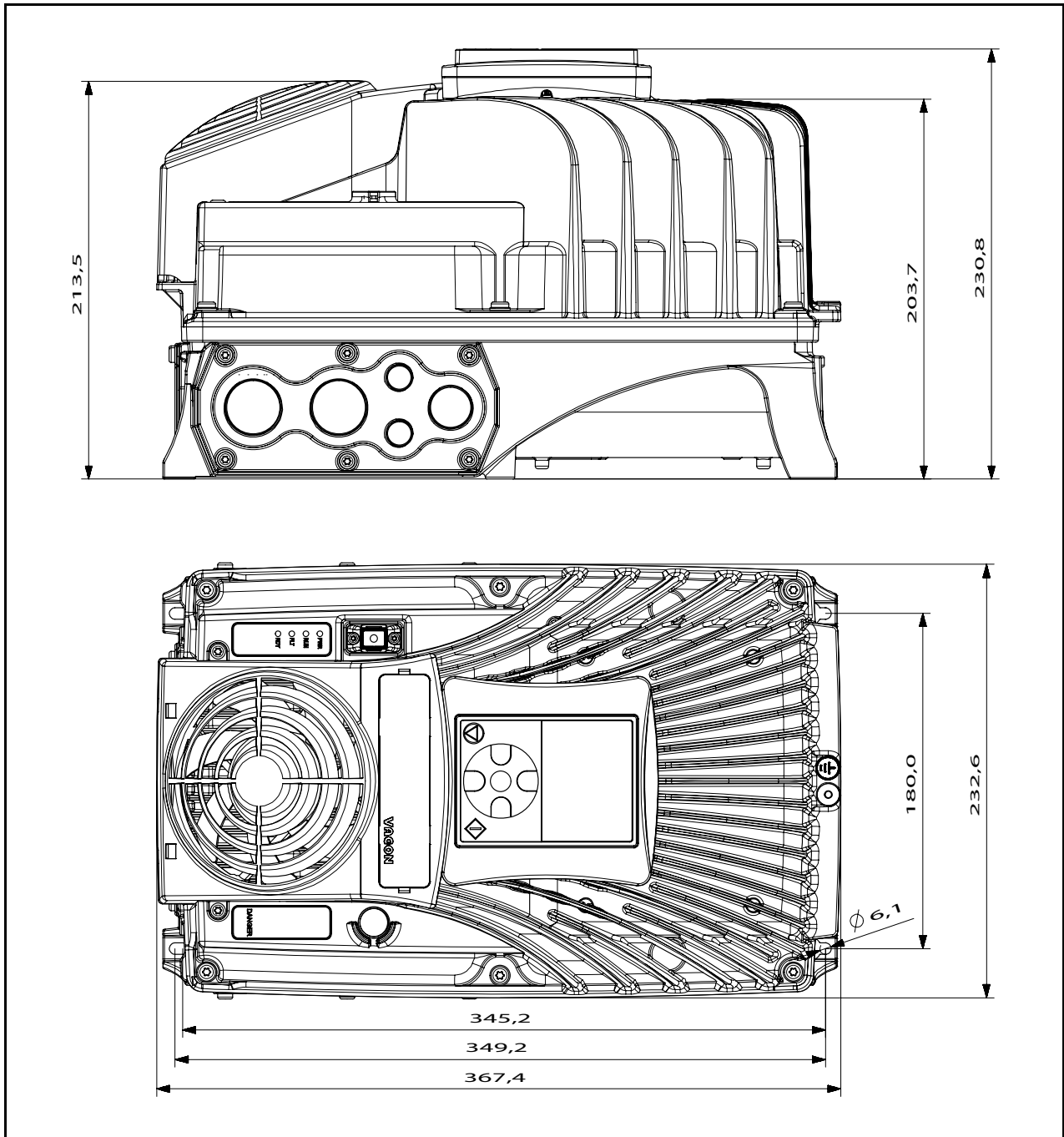

Figure 10. VACON<sup>®</sup> 100 X drive dimensions, MM5

| Enclosure size | Dimensions W x H x D  |                     |
|----------------|-----------------------|---------------------|
|                | [mm]                  | [in]                |
| MM5            | 232.6 x 367.4 x 213.5 | 9.16 x 14.46 x 8.41 |
| MM5 +HMGR      | 232.6 x 367.4 x 230.8 | 9.16 x 14.46 x 9.08 |

## 3.3 DIMENSIONS MM6

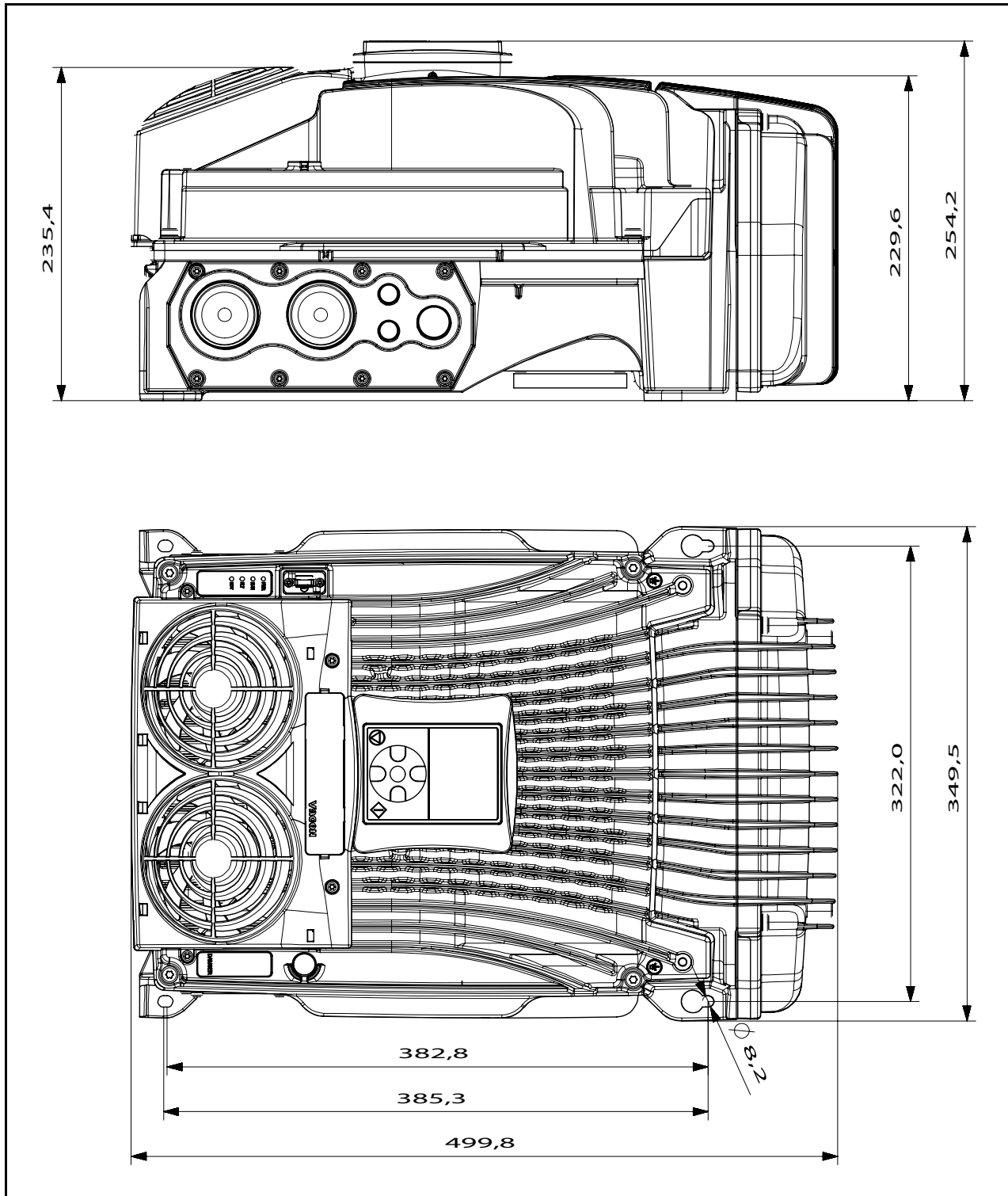

Figure 11. VACON® 100 X drive dimensions, MM6

| Enclosure size | Dimensions W x H x D  |                       |
|----------------|-----------------------|-----------------------|
|                | [mm]                  | [in]                  |
| MM6            | 349.5 x 499.8 x 235.4 | 13.76 x 19.68 x 9.27  |
| MM6 +HMGR      | 349.5 x 499.8 x 254.2 | 13.76 x 19.68 x 10.00 |

### 3.4 INTRODUCTION OF MODULES

The mechanical concept of VACON® 100 X drive is based on two segregated parts, power and control, connected to each other by pluggable terminals. The power unit, called powerhead, includes all the power electronics such as the EMC-filter, IGBTs, capacitors, choke or power boards while the control board and the control terminals are located in the terminal box.

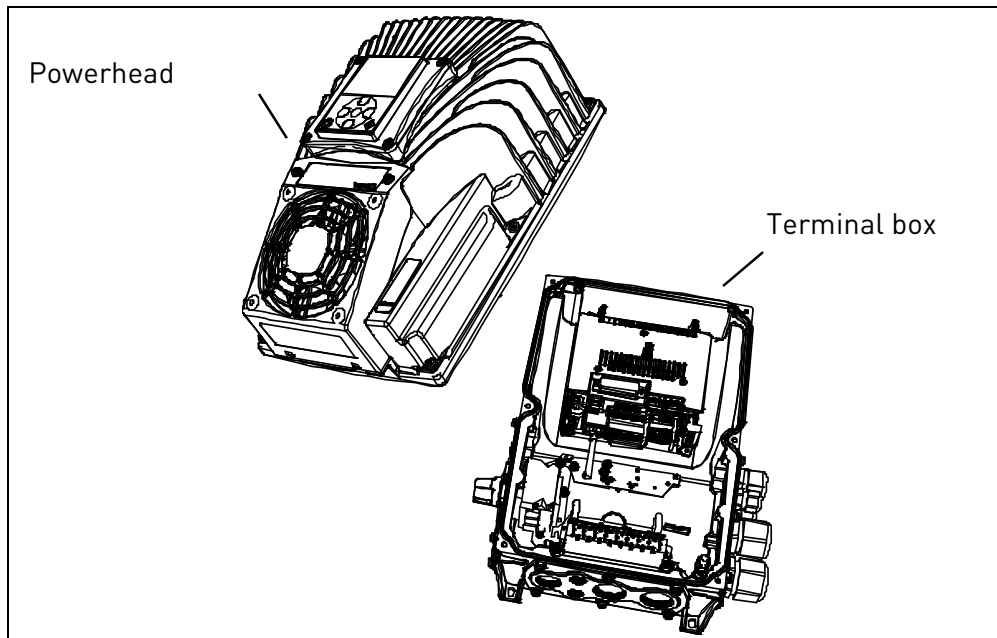

Figure 12. VACON® 100 X drive modules



### 3.5 MOUNTING

The drive consists of two main elements:

1. The terminal box that includes the power terminals and control board with the control terminals and
2. The powerhead containing all the power electronics.

To install the drive, both parts need to be separated. The terminal box must be fixed first and all cabling done. After this, the powerhead will be plugged on the terminal box and fixed with 4 (MM4 and MM6) or 6 (MM5) dedicated screws located on top side of the powerhead (see Figure 13.). In order to guarantee specified IP protection, recommended fastening torque is 2-3 Nm. The screws must be tightened crosswise.

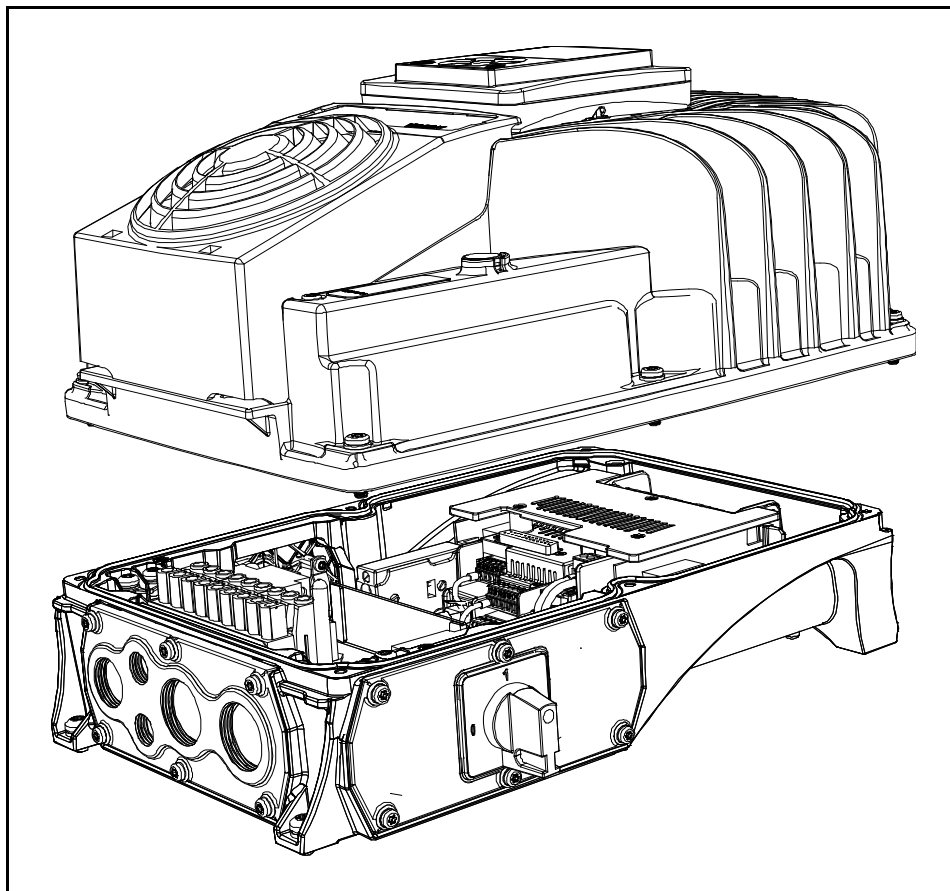

Figure 13. Separation of modules (MM5 example)

### 3.5.1 WALL-MOUNTING

The drive can be mounted in vertical or horizontal position on the wall or any other relatively even mounting plane or machine frame and fixed with the screws recommended in Table 8.

Recommended screw or bolt size for MM4 is M5, for MM5 M6 and MM6 is M8.

Table 8. Screws for wall mounting.

| Enclosure size | Screw number | Screw size |
|----------------|--------------|------------|
| MM4            | 4            | M5         |
| MM5            | 4            | M6         |
| MM6            | 4            | M8         |

### 3.5.2 MOTOR-MOUNTING

The drive can also be mounted on a motor (on top or on any side of the motor). The drive is equipped with a cooling system independent of the motor. Motor-mounting requires special adapting components. Contact your local distributor for additional information.

### 3.5.3 SEGREGATED MODULES

In order to ease replacements in case of failure, the power and the control sub-systems are enclosed in two segregated parts, connected together through pluggable terminals:

- Power-head: heat-sink enclosing all power electronics
- Terminal-box: block containing unit control and power terminals

Firstly, the terminal-box has to be fixed and the cabling has to be done. Secondly, the power-head has to be plugged and fixed to the terminal-box with dedicated screws (see Table 9). In order to preserve the specified IP protection class, **the recommended fastening torque is 2-3 Nm.**

Table 9. Screws for fixing the powerhead to the terminal box.

| Enclosure size | Screw number | Screw size |
|----------------|--------------|------------|
| MM4            | 4            | M5         |
| MM5            | 6            | M5         |
| MM6            | 4            | M6         |

### 3.6 COOLING

The AC drive produces heat in operation and is cooled down by air circulated by a fan. The cooling concept is independent of the motor fan.

Enough free space must be left around the AC drive to ensure sufficient air circulation and cooling. Different acts of maintenance may also require a certain amount of free space.

The minimum clearances given in Table 10 must not be exceeded. It is also important to ensure that the temperature of the cooling air does not exceed the maximum ambient temperature of the drive.

Contact local distributor for more information on required clearances in different installations.

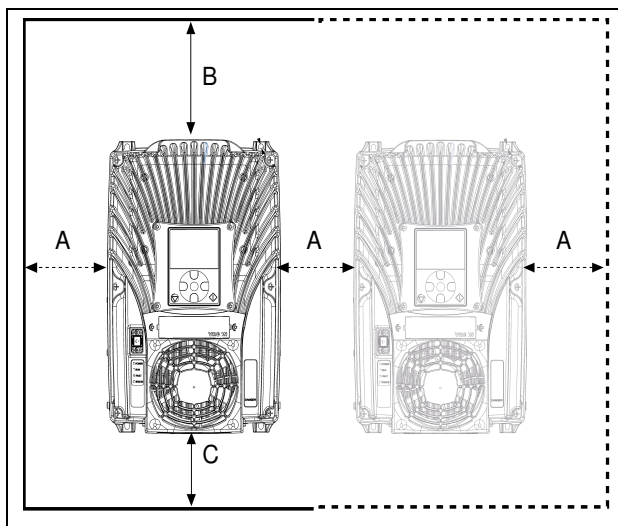

| Min clearance [mm] |    |     |    |
|--------------------|----|-----|----|
| Type               | A  | B   | C  |
| All types          | 80 | 160 | 60 |

Table 10. Min. clearances around AC drive.

- A = Clearance left and right from the drive
- B = Clearance above the drive
- C = Clearance underneath the AC drive

Figure 14. Installation space

Table 11. Required cooling air.

| Type | Cooling air required [m³/h] |
|------|-----------------------------|
| MM4  | 140                         |
| MM5  | 140                         |
| MM6  | 280                         |

Should you need further details on the cooling system of the VACON® 100 X, please contact your local distributor.

## 4. POWER CABLING

The mains cables are connected to terminals L1, L2 and L3 and the motor cables to terminals marked with U, V and W. See principal connection diagram in Figure 15. See also Table 12 for the cable recommendations for different EMC levels.

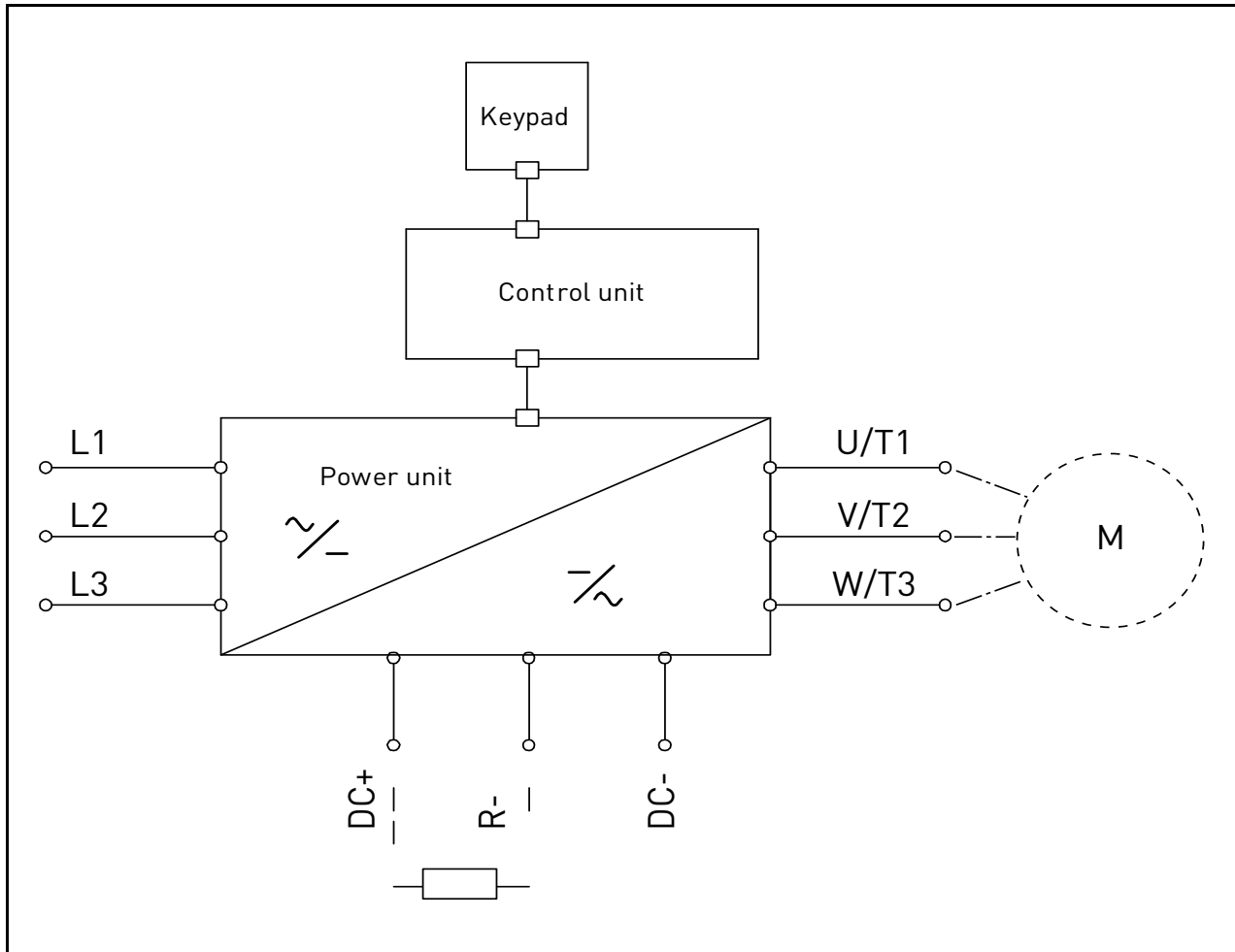

Figure 15. Principal connection diagram

Use cables with heat resistance in accordance with the application requirements. The cables and the fuses must be dimensioned according to the AC drive nominal OUTPUT current which you can find on the rating plate.

Table 12. Cable types required to meet standards.

| Cable type    | EMC levels                  |                             |             |
|---------------|-----------------------------|-----------------------------|-------------|
|               | 1 <sup>st</sup> environment | 2 <sup>nd</sup> environment |             |
|               | Category C2                 | Category C3                 | Category C4 |
| Mains cable   | 1                           | 1                           | 1           |
| Motor cable   | 3*                          | 2                           | 2           |
| Control cable | 4                           | 4                           | 4           |

- 1 = Power cable intended for fixed installation and the specific mains voltage. Shielded cable not required. (MCMK or similar recommended).
- 2 = Symmetrical power cable equipped with concentric protection wire and intended for the specific mains voltage. (MCMK or similar recommended). See Figure 16.
- 3 = Symmetrical power cable equipped with compact low-impedance shield and intended for the specific mains voltage. [MCCMK, EMCMK or similar recommended. See Figure 16.  
\*360° grounding of the shield with cable glands in motor end needed for EMC level C2.
- 4 = Screened cable equipped with compact low-impedance shield (JAMAK, SAB/ÖZCuY-0 or similar).

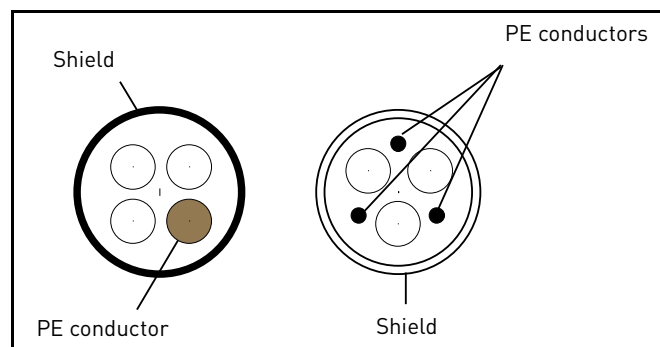

Figure 16.

**NOTE:** The EMC requirements are fulfilled at factory defaults of switching frequencies (all frames).  
**NOTE:** If safety switch is connected, the EMC protection must be continuous over the whole cable installation.

#### 4.1 CIRCUIT BREAKER

Please disconnect the drive via an external circuit breaker. You have to provide a switching device between supply and main connection terminals.

When connecting the input terminals to the power supply using a circuit breaker, observe that this is of **type B or type C** and ensure it has a **capacity of 1.5 to 2 times of the inverter's rated current** (see Table and Table 31).

**NOTE:** circuit breaker is not allowed in installations where C-UL is required. Only fuses are recommended.

#### 4.2 UL STANDARDS ON CABLING

To meet the UL (Underwriters Laboratories) regulations, use a UL-approved copper cable with a minimum heat-resistance of +75°C. Use Class 1 wire only.

The units are suitable for use on a circuit capable of delivering not more than 100,000 rms symmetrical amperes, 500V AC maximum, when protected by T or J class fuses.



Integral solid state short circuit protection does not provide branch circuit protection. Branch circuit protection must be provided in accordance with the **National Electrical Code** and any additional local codes.

---

### 4.3 DESCRIPTION OF THE TERMINALS

The following pictures describe the power terminals and the typical connections in VACON® 100 X drives.

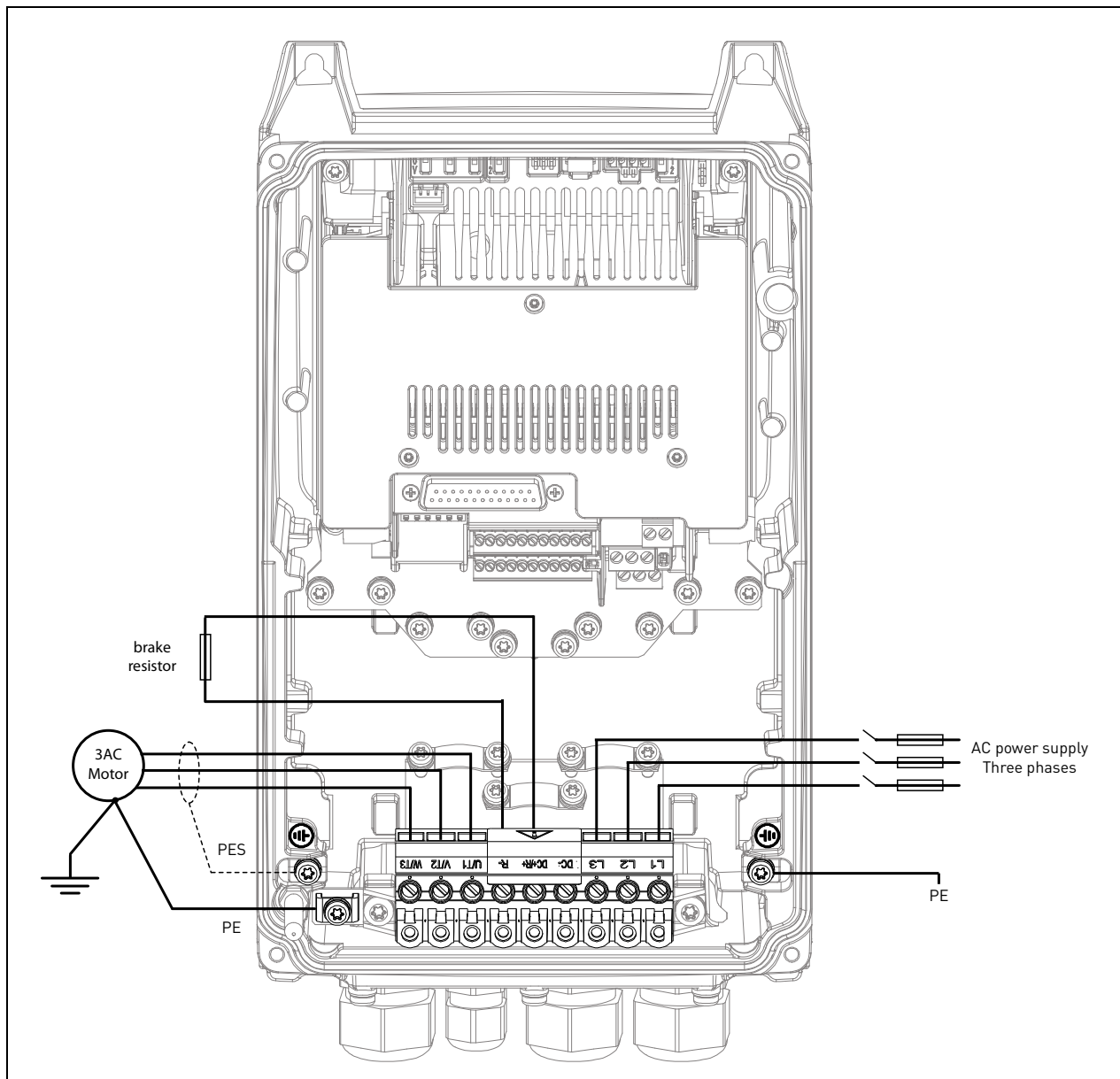

Figure 17. Power connections, MM4

Table 13. Terminal description.

| Terminal             | Description   |
|----------------------|---|
| L1<br>L2<br>L3       | These terminals are the input connections for the power supply. |
| DC-<br>DC+/R+<br>R-  | DC bus terminals (DC- DC+) and Brake resistor terminals (R+ R-) |
| U/T1<br>V/T2<br>W/T3 | These terminals are for motor connections.                      |

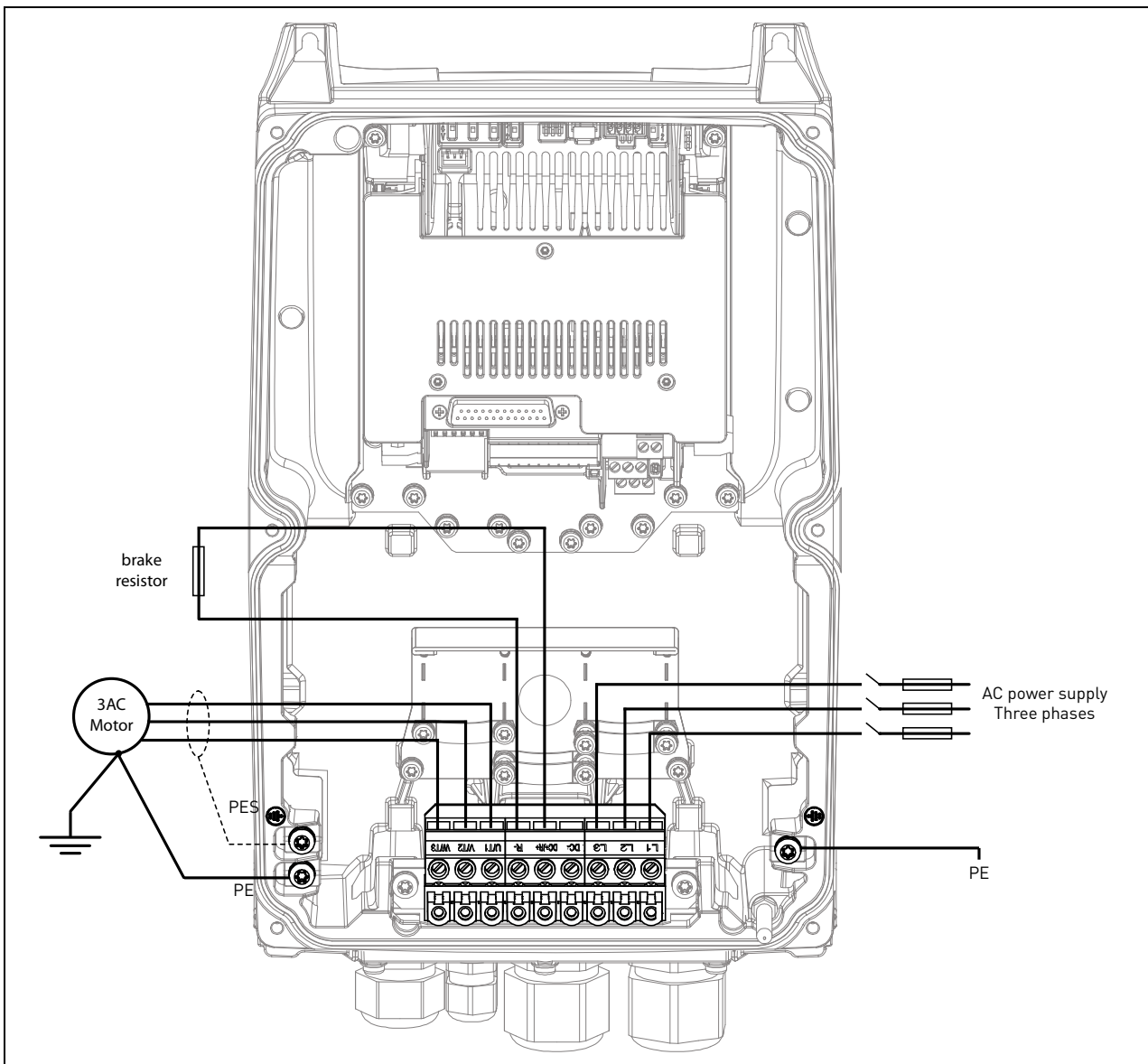

Figure 18. Power connections, MM5

Table 14. Terminal description.

| Terminal             | Description   |
|----------------------|---|
| L1<br>L2<br>L3       | These terminals are the input connections for the power supply. |
| DC-<br>DC+/R+<br>R-  | DC bus terminals (DC- DC+) and Brake resistor terminals (R+ R-) |
| U/T1<br>V/T2<br>W/T3 | These terminals are for motor connections.                      |



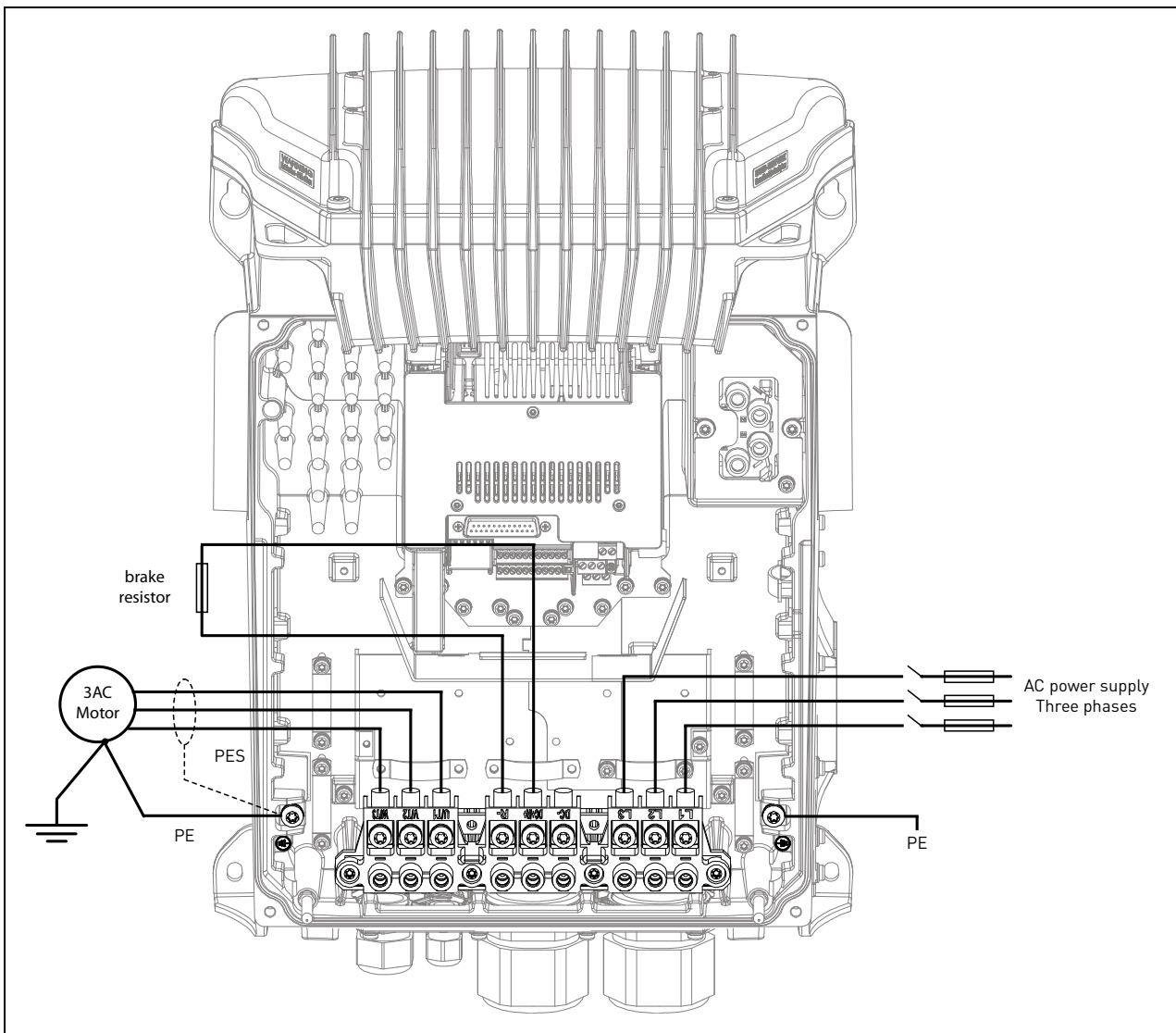

Figure 19. Power connections, MM6

Table 15. Terminal description.

| Terminal             | Description   |
|----------------------|---|
| L1<br>L2<br>L3       | These terminals are the input connections for the power supply. |
| DC-<br>DC+/R+<br>R-  | DC bus terminals (DC- DC+) and Brake resistor terminals (R+ R-) |
| U/T1<br>V/T2<br>W/T3 | These terminals are for motor connections.                      |

**4.4 CABLE DIMENSIONING AND SELECTION**

Table 16 and Table 17 show the minimum dimensions of the Cu-cables and the corresponding fuse sizes.

These instructions apply only to cases with one motor and one cable connection from the AC drive to the motor. In any other case, ask the factory for more information.

**4.4.1 CABLE AND FUSE SIZES, ENCLOSURES MM4 TO MM6**

The recommended fuse type is gG/gL (IEC 60269-1). The fuse voltage rating must be selected according to the supply network. The final selection must be made according to local regulations, cable installation conditions and cable specification. Bigger fuses than those recommended below must not be used.

Check that the fuse operating time is less than 0.4 seconds. Operating time depends on used fuse type and impedance of the supply circuit. Consult the factory about faster fuses. The manufacturer also recommends high speed gS (IEC 60269-4) fuse ranges.

Table 16. Cable and fuse sizes for VACON® 100 X.

| Enclosure size | Type  | I <sub>INPUT</sub> [A]   | Fuse (gG/gL) [A] | Mains, motor and brake resistor* cable Cu [mm <sup>2</sup> ] | Terminal cable size              |                                   |
|----------------|---|--------------------------|------------------|--|----------------------------------|-----------------------------------|
|                |   |                          |                  |  | Main terminal [mm <sup>2</sup> ] | Earth terminal [mm <sup>2</sup> ] |
| MM4            | 0003 4 - 0004 4<br>0003 5 - 0004 5                    | 3.4 - 4.6                | 6                | 3*1.5+1.5  | 0.5—10 solid<br>0.5—6 stranded   | M4 ring terminal<br>or 1—6        |
|                | 0006 2 - 0008 2<br>0005 4 - 0008 4<br>0005 5 - 0008 5 | 6.0 - 7.2<br>5.4 - 8.1   | 10               | 3*1.5+1.5  | 0.5—10 solid<br>0.5—6 stranded   | M4 ring terminal<br>or 1—6        |
|                | 0011 2 - 0012 2<br>0009 4 - 0012 4<br>0009 5 - 0012 5 | 9.7 - 10.9<br>9.3 - 11.3 | 16               | 3*2.5+2.5  | 0.5—10 solid<br>0.5—6 stranded   | M4 ring terminal<br>or 1—6        |
| MM5            | 0018 2<br>0016 4<br>0016 5                            | 16.1<br>15.4             | 20               | 3*6+6  | 0.5—16 solid<br>or stranded      | M5 ring terminal<br>or 1—10       |
|                | 0024 2<br>0023 4<br>0023 5                            | 21.7<br>21.3             | 25               | 3*6+6  | 0.5—16 solid<br>or stranded      | M5 ring terminal<br>or 1—10       |
|                | 0031 2<br>0031 4<br>0031 5                            | 27.7<br>28.4             | 32               | 3*10+10  | 0.5—16 solid or<br>stranded      | M5 ring terminal<br>or 1—10       |
| MM6            | 0038 4<br>0038 5                                      | 36.7                     | 40               | 3*10+10  | M6 ring terminal                 | M6 ring terminal                  |
|                | 0048 2<br>0046 4<br>0046 5                            | 43.8<br>43.6             | 50               | 3*16+16  | M6 ring terminal                 | M6 ring terminal                  |
|                | 0062 2<br>0061 4<br>0061 5                            | 57.0<br>58.2             | 63               | 3*25+16  | M6 ring terminal                 | M6 ring terminal                  |
|                | 0072 4<br>0072 5                                      | 67.5                     | 80               | 3*35+16  | M6 ring terminal                 | M6 ring terminal                  |

The terminal sizes are intended for 1 conductor. For MM6, the max. diameter of the ring terminal is 14 mm. The cable dimensioning is based on the criteria of the International Standard **IEC60364-5-52**: Cables must be PVC-isolated; Max number of parallel cables is 9.

When using cables in parallel, **NOTE HOWEVER** that the requirements of both the cross-sectional area and the max number of cables must be observed.

For important information on the requirements of the grounding conductor, see chapter Grounding and earth fault protection of the standard.

For the correction factors for each temperature, see International Standard **IEC60364-5-52**.

#### 4.4.2 CABLE AND FUSE SIZES, ENCLOSURES MM4 TO MM6, NORTH AMERICA

The recommended fuse type is class T (UL & CSA). The fuse voltage rating must be selected according to the supply network. The final selection must be made according to local regulations, cable installation conditions and cable specification. Bigger fuses than those recommended below must not be used.

Check that the fuse operating time is less than 0.4 seconds. Operating time depends on used fuse type and impedance of the supply circuit. Consult the factory about faster fuses. The manufacturer also recommends high speed J (UL & CSA) fuse ranges.

Table 17. Cable and fuse sizes for VACON® 100 X.

| Enclosure size | Type  | I <sub>INPUT</sub> [A] | Fuse (class T) [A] | Mains and motor cable Cu | Terminal cable size |                                 |
|----------------|---|------------------------|--------------------|--------------------------|---------------------|---------------------------------|
|                |   |                        |                    |                          | Main terminal       | Earth terminal                  |
| MM4            | 0003 4 - 0004 4<br>0003 5 - 0004 5                    | 3.4 - 4.6              | 6                  | AWG14                    | AWG24-AWG10         | AWG17-AWG10<br>M4 ring terminal |
|                | 0006 2 - 0008 2<br>0005 4 - 0008 4<br>0005 5 - 0008 5 | 6.0 - 7.2<br>5.4 - 8.1 | 10                 | AWG14                    | AWG24-AWG10         | AWG17-AWG10<br>M4 ring terminal |
|                | 0011 2<br>0009 4<br>0009 5                            | 9.7<br>9.3             | 15                 | AWG14                    | AWG24-AWG10         | AWG17-AWG10<br>M4 ring terminal |
|                | 0012 2<br>0012 4<br>0012 5                            | 10.9<br>11.3           | 20                 | AWG14                    | AWG24-AWG10         | AWG17-AWG10<br>M4 ring terminal |
| MM5            | 0018 2<br>0016 4<br>0016 5                            | 16.1<br>15.4           | 25                 | AWG10                    | AWG20-AWG5          | AWG17-AWG8<br>M5 ring terminal  |
|                | 0024 2<br>0023 4<br>0023 5                            | 21.7<br>21.3           | 30                 | AWG10                    | AWG20-AWG5          | AWG17-AWG8<br>M5 ring terminal  |
|                | 0031 2<br>0031 4<br>0031 5                            | 27.7<br>28.4           | 40                 | AWG8                     | AWG20-AWG5          | AWG17-AWG8<br>M5 ring terminal  |

Table 17. Cable and fuse sizes for VACON® 100 X.

| Enclosure size | Type     | I <sub>INPUT</sub> [A] | Fuse (class T) [A] | Mains and motor cable Cu | Terminal cable size |                  |
|----------------|----------|------------------------|--------------------|--------------------------|---------------------|------------------|
|                |          |                        |                    |                          | Main terminal       | Earth terminal   |
| MM6            | 0038 4*  | 36.7                   | 50                 | AWG4                     | AWG13-AWG0          | AWG13-AWG2       |
|                | 0038 5*  |                        |                    |                          | M6 ring terminal    | M6 ring terminal |
|                | 0048 2*  | 43.8                   | 60                 | AWG4                     | AWG13-AWG0          | AWG13-AWG2       |
|                | 0046 4*  |                        |                    |                          | M6 ring terminal    | M6 ring terminal |
|                | 0046 5*  |                        |                    |                          | 43.6                |                  |
|                | 0062 2** | 57.0                   | 80                 | AWG4                     | AWG13-AWG0          | AWG13-AWG2       |
|                | 0061 4** |                        |                    |                          | M6 ring terminal    | M6 ring terminal |
|                | 0061 5** |                        |                    |                          | 58.2                |                  |
|                | 0072 4** | 67.5                   | 100                | AWG2                     | AWG9-AWG2/0         | AWG9-AWG2/0      |
|                | 0072 5** |                        |                    |                          | M6 ring terminal    | M6 ring terminal |

\* With the optional mains switch, the mains cable must be rated AWG6 (minimum 75°C, Cu). The motor cable must be rated AWG4 (minimum 75°C, Cu).

\*\* The optional mains switch cannot be used with these models, unless current derating is applied. The input current cannot exceed 52 A at 30°C ambient temperature and 45 A at 40°C ambient temperature. With the optional main switch, use a maximum 60 A fuse.

The cable dimensioning is based on the criteria of the **Underwriters' Laboratories UL508C**: Cables must be PVC-isolated; Max ambient temperature +40 °C (104 °F), max temperature of cable surface +75 °C (167 °F); Use only cables with concentric copper shield; Max number of parallel cables is 9.

When using cables in parallel, **NOTE HOWEVER** that the requirements of both the cross-sectional area and the max number of cables must be observed. For important information on the requirements of the grounding conductor, see standard Underwriters' Laboratories UL508C.

For the correction factors for each temperature, see the instructions of standard **Underwriters' Laboratories UL508C**.

**4.4.3 BRAKE RESISTOR CABLES**

VACON® 100 X AC drives are equipped with terminals for an optional external brake resistor. These terminals are marked with **DC+/R+** and **R-**. See Table 33 and Table 34 for the resistor ratings and Table 16 for cable sizing.

**4.4.4 CONTROL CABLES**

For information on control cables see chapter Control unit.

#### 4.5 CABLE INSTALLATION

- Before starting, check that none of the components of the AC drive is live. Read carefully the warnings in chapter 1.
- Place the motor cables sufficiently far from other cables.
- Avoid placing the motor cables in long parallel lines with other cables.
- If the motor cables run in parallel with other cables note the minimum distances between the motor cables and other cables given in table below.

| Distance between cables, [m] | Shielded cable, [m] |
|------------------------------|---------------------|
| 0.3                          | ≤ 50                |
| 1.0                          | ≤ 200               |

- The given distances also apply between the motor cables and signal cables of other systems.
- The **maximum lengths of motor cables** (shielded) are 100 m (MM4) and 150 m (MM5 and MM6).
- The motor cables should cross other cables at an angle of 90 degrees.
- If cable insulation checks are needed, see chapter Cable and motor insulation checks.

Start the cable installation according to the instructions below:

**1**

Strip the motor and mains cables as recommended below.

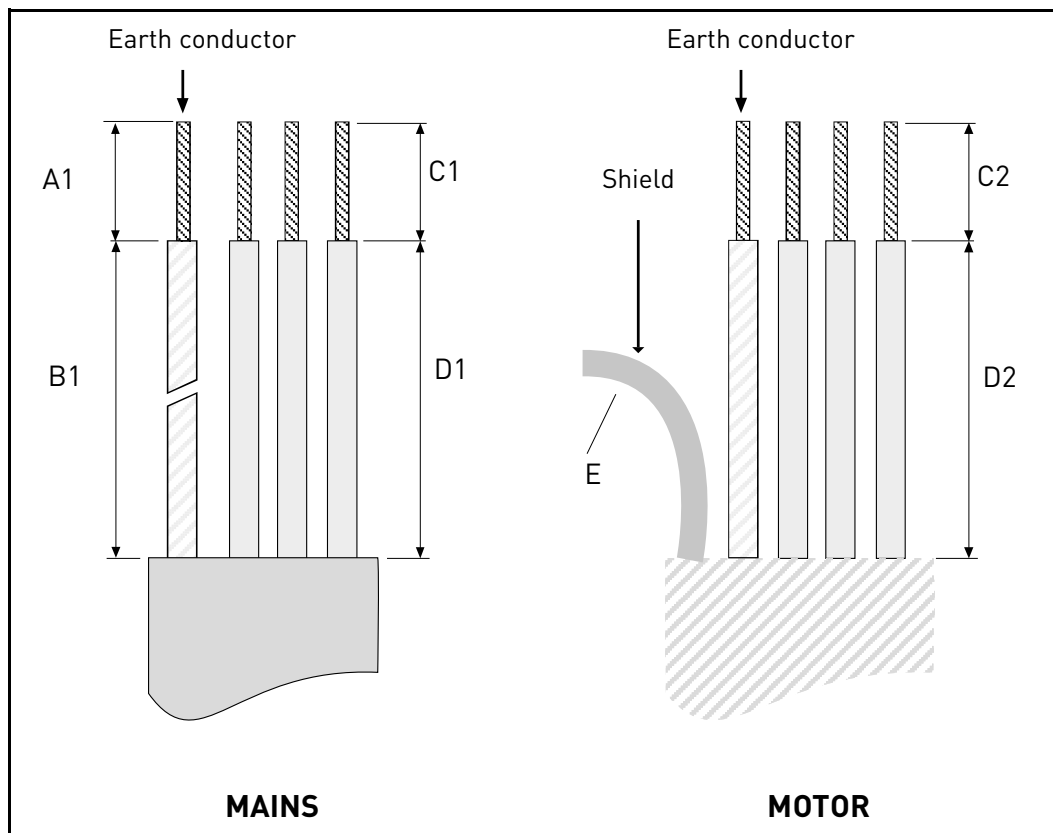

Figure 20. Stripping of cables

Table 18. Cables stripping lengths [mm].

| Enclosure size | A1 | B1 | C1 | D1 | C2 | D2 | E                    |
|----------------|----|----|----|----|----|----|----------------------|
| MM4            | 15 | 70 | 10 | 30 | 7  | 30 | as short as possible |
| MM5            | 20 | 70 | 10 | 40 | 10 | 40 |                      |
| MM6            | 20 | 90 | 15 | 60 | 15 | 60 |                      |

**IEC installation:**

|          |   |
|----------|---|
| <b>2</b> | <ul style="list-style-type: none"> <li>Remove the cable entry plate. The cable entry system is a combination of a cable entry plate (see the figure below) and cable glands. In the cable entry plate there are several openings available for the cables with ISO metric thread.</li> <li>Open only the inlet holes where you need to run the cables.</li> </ul> |
| <b>3</b> | <ul style="list-style-type: none"> <li>Choose the correct cable glands according to drive and cable size as shown in the following pictures.</li> </ul>   |

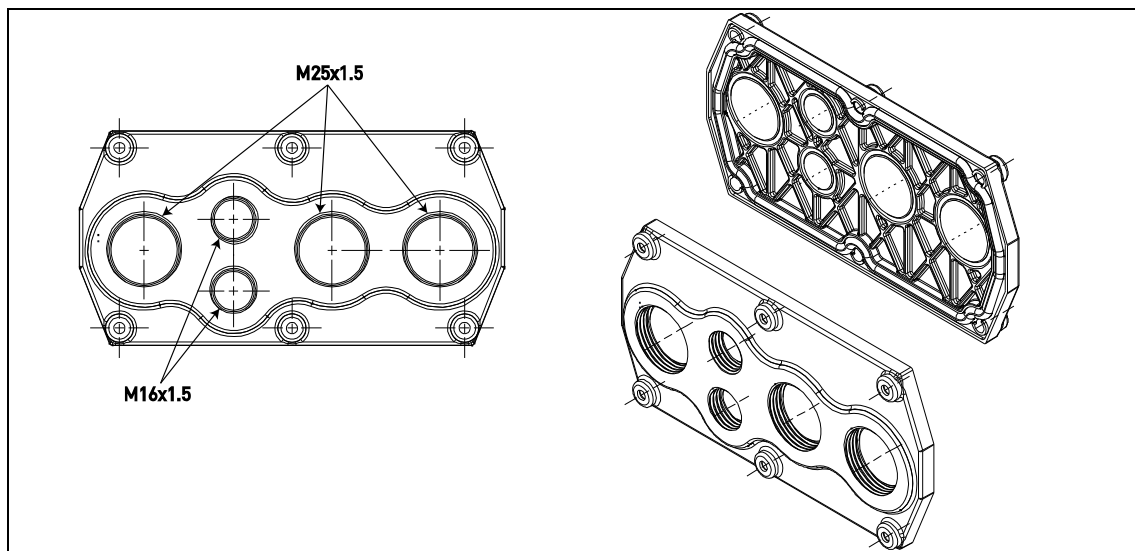

Figure 21. Cable entry plate, MM4

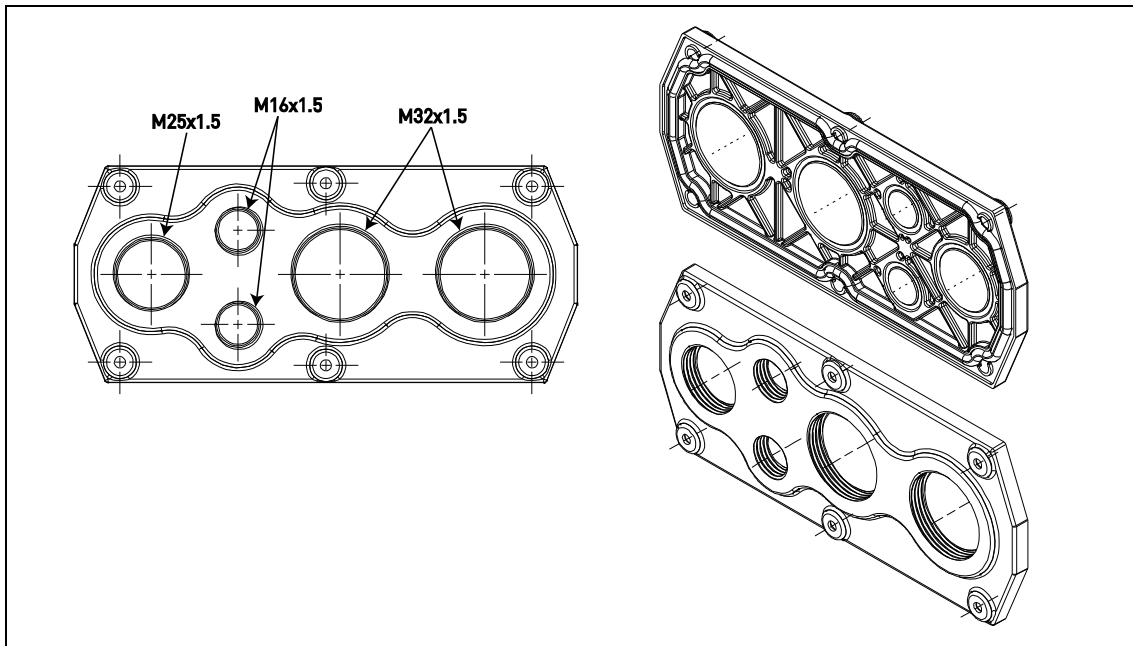

Figure 22. Cable entry plate, MM5

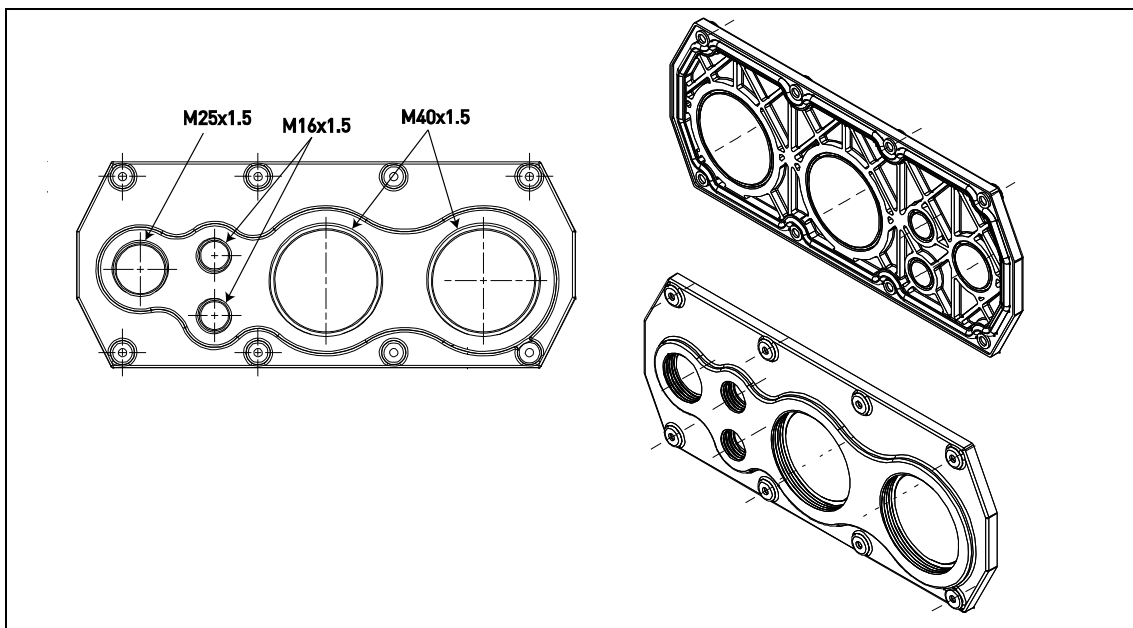

Figure 23. Cable entry plate, MM6

- |          |  |
|----------|--|
| <b>4</b> | <ul style="list-style-type: none"> <li>• Cable glands must be made of plastic materials. They are used for sealing cables passing through cable entries to ensure the characteristics of the enclosure.</li> </ul> |
|----------|--|

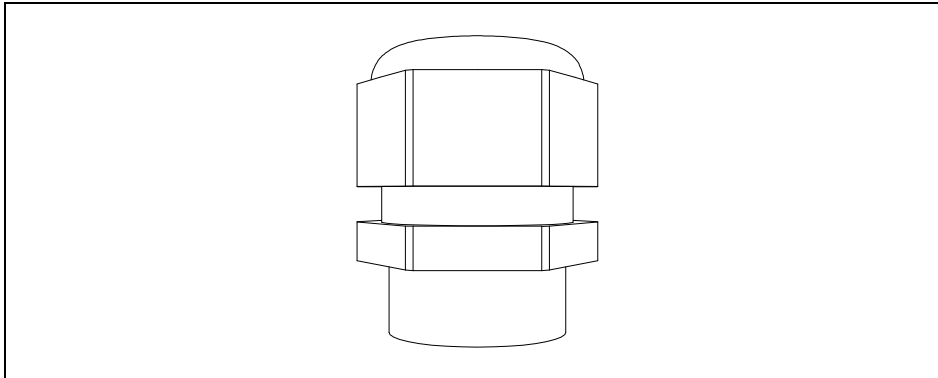

Figure 24. Cable gland



Plastic cable glands are recommend. If metal cable glands are needed, all insulation system requirements and all protective grounding requirements have to be fulfilled in accordance with the national electrical regulations and IEC 61800-5-1.

- |          |  |
|----------|--|
| <b>5</b> | <ul style="list-style-type: none"> <li>• Screw the cable glands on the cable entry holes using the proper tightening torque as shown in Table 19.</li> </ul> |
|----------|--|

**Tightening torques of cable glands:**

Table 19. Tightening torque and dimension of cable glands.

| Enclosure size | Gland screw type [metric] | Tightening torque [Nm]/[lb-in.] |        |
|----------------|---------------------------|---------------------------------|--------|
|                |                           | [Nm]                            | lb-in. |
| <b>MM4</b>     | M16                       | 1.0                             | 8.9    |
|                | M25                       | 4.0                             | 35.5   |
| <b>MM5</b>     | M16                       | 1.0                             | 8.9    |
|                | M25                       | 4.0                             | 35.5   |
|                | M32                       | 7.0                             | 62.1   |
| <b>MM6</b>     | M16                       | 1.0                             | 8.9    |
|                | M25                       | 4.0                             | 35.5   |
|                | M40                       | 10.0                            | 88.7   |



## UL installation:

6

- To connect NPT pipes to VACON<sup>®</sup> 100 X, use the optional metal cable entry plate (included in -R02 option) to meet UL installation rules.
- One metal conduit plate with accessories (screws and gasket) is delivered in a separate bag together with the drive. See the following figures for more details.

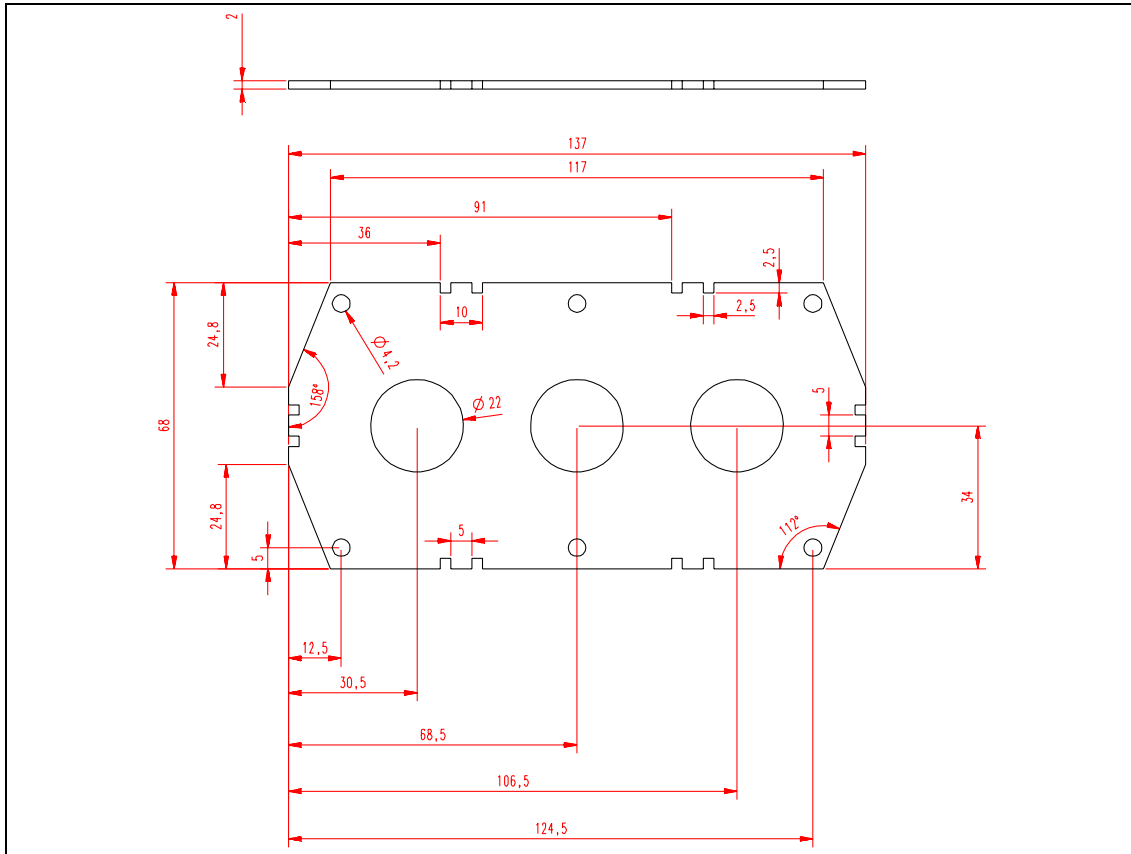

Figure 25. Cable entry plate, MM4 UL installation

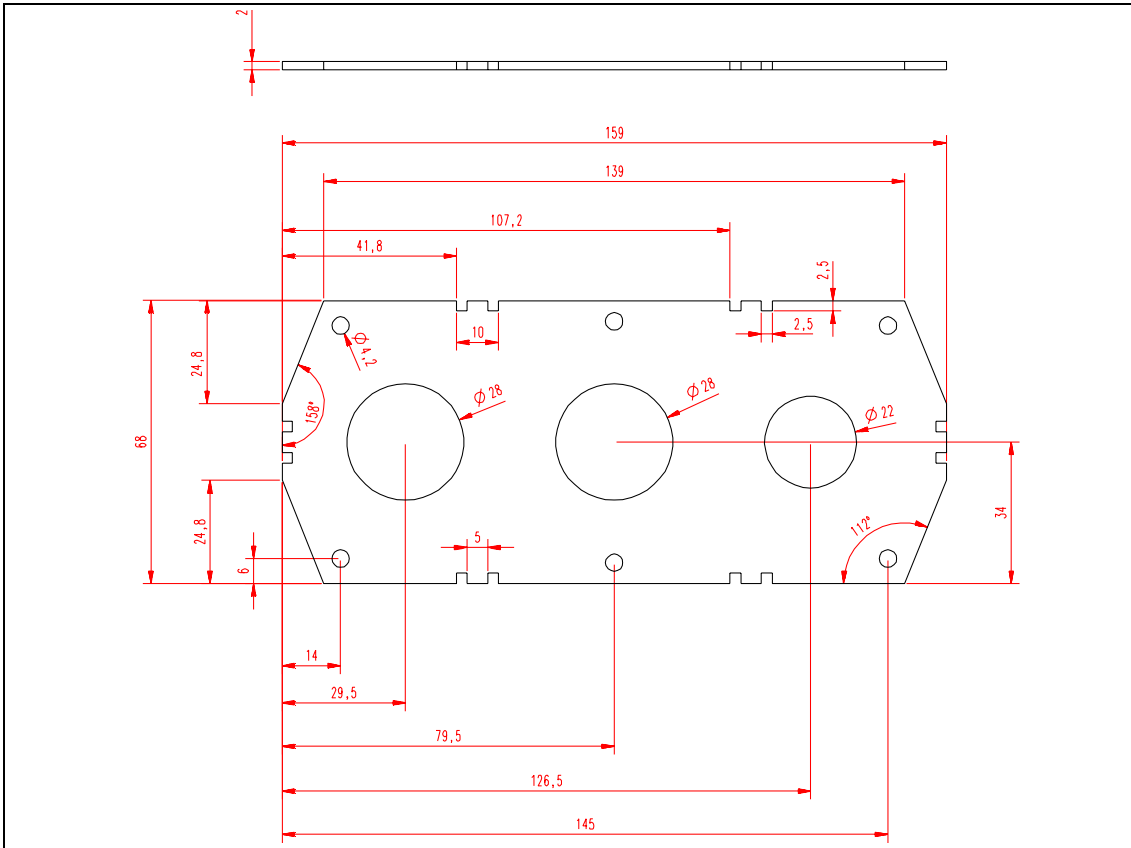

Figure 26. Cable entry plate, MM5 UL installation

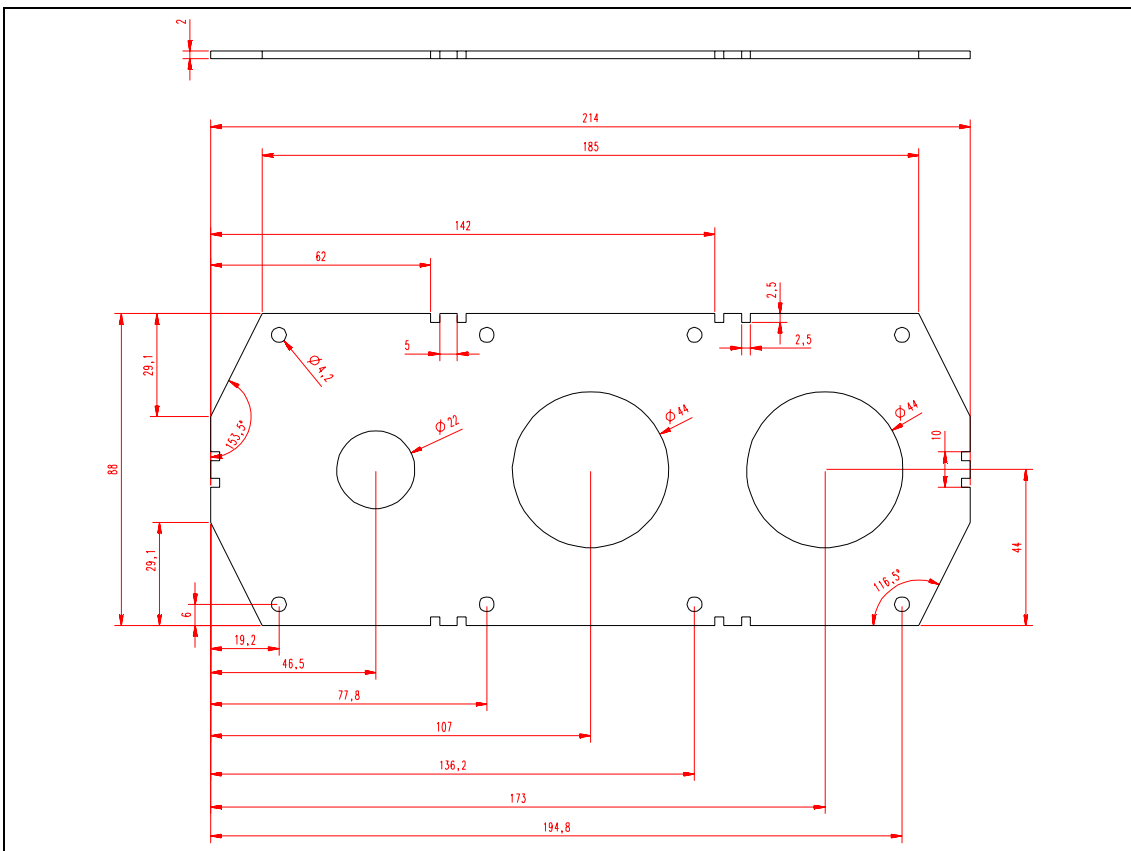

Figure 27. Cable entry plate, MM6 UL installation

|           |   |
|-----------|---|
| <b>7</b>  | <ul style="list-style-type: none"> <li>All the (3) terminal box openings are closed with the standard plastic plates with the metric threads.</li> </ul>  |
| <b>8</b>  | <ul style="list-style-type: none"> <li>The metal cable entry plate for UL installation has to be installed in place of one of standard plastic cable entries provided with the default package. The tightening torque of cable entry plate screws: 1.5 -2.0 Nm (13.2-17.7 lb-in). The metal cable entry plate has three not-threaded openings: input line, motor and I/Os and can be mounted only on left or right-hand side of the drive.</li> </ul> |
| <b>9</b>  | <ul style="list-style-type: none"> <li>Flexible or rigid cable conduit can be used.</li> <li>Use proper fittings to join and terminate rigid conduit tubing, and protect it from damage too.</li> <li>The proper selection of electrical conduit materials, fittings, and installation are important for safe electrical wiring.</li> </ul>   |
| <b>10</b> | <ul style="list-style-type: none"> <li>Setscrew fittings are commonly used with conduit; they provide weather tight joints that are firm to keep the IP degree of the drive.</li> </ul>   |

**Cable installation:**

|           |   |
|-----------|---|
| <b>11</b> | <ul style="list-style-type: none"> <li>Pass the cables (supply cable, motor cable, brake cable and I/O cables) through the conduits (UL connections) or through the cable glands (IEC connections) and cable entries.</li> </ul>  |
| <b>12</b> | <ul style="list-style-type: none"> <li>Detach the cable clamps and the grounding clamps.</li> </ul>   |
| <b>13</b> | <p>Connect the stripped cables:</p> <ul style="list-style-type: none"> <li>Expose the shield of both cables in order to make a 360-degree connection with the cable clamp (reverse the shield over the plastic cover of the cable and fix all together).</li> <li>Connect the phase conductors of the supply and motor cables into their respective terminals.</li> <li>Form the rest of the cable shield of both cables into "pigtailes" and make a grounding connection with the clamp. Make the pigtailes just long enough to reach and be fixed to the terminal - no longer.</li> </ul> |

**Tightening torques of cable terminals:**

*Table 20. Tightening torques of terminals.*

| Enclosure size | Type            | Tightening torque [Nm]/[lb-in.] Power and motor terminals |           | Tightening torque [Nm]/[lb-in.] EMC grounding clamps |        | Tightening torque, [Nm]/[lb-in.] Grounding terminals |        |
|----------------|-----------------|---|-----------|--|--------|--|--------|
|                |                 | [Nm]  | lb-in.    | [Nm]   | lb-in. | [Nm]   | lb-in. |
| <b>MM4</b>     | 0006 2 - 0012 2 | 1.2—1.5   | 10.6—13.3 | 1.5  | 13.3   | 2.0  | 17.7   |
|                | 0003 4 - 0012 4 |   |           |  |        |  |        |
|                | 0003 5 - 0012 5 |   |           |  |        |  |        |
| <b>MM5</b>     | 0018 2 - 0031 2 | 1.2—1.5   | 10.6—13.3 | 1.5  | 13.3   | 2.0  | 17.7   |
|                | 0016 4 - 0031 4 |   |           |  |        |  |        |
|                | 0016 5 - 0031 5 |   |           |  |        |  |        |
| <b>MM6</b>     | 0048 2 - 0062 2 | 4—5   | 35.4—44.3 | 1.5  | 13.3   | 2.0  | 17.7   |
|                | 0038 4 - 0072 4 |   |           |  |        |  |        |
|                | 0038 5 - 0072 5 |   |           |  |        |  |        |

|           |  |
|-----------|--|
| <b>14</b> | <ul style="list-style-type: none"> <li>Check the connection of the earth cable to the motor and the AC drive terminals marked with .</li> </ul> |
|-----------|--|

## 5. CONTROL UNIT

Remove the powerhead of the drive to reveal the terminal box with the control terminals.

The control unit of the AC drive consists of the control board and additional boards (option boards) connected to the slot connectors of the control board. The locations of boards, terminals and switches are presented in Figure 28 below.

Table 21. Locations of components in control unit.

| Number | Meaning  |
|--------|--|
| 1      | Control terminals 1-11 (see chapter 5.1.2)       |
| 2      | Control terminals 12-30, A-B (see chapter 5.1.2) |
| 3      | Relay terminals (see chapter 5.1.2)              |
| 4      | Thermistor input (see chapter 5.1.2)             |
| 5      | STO terminals                                    |
| 6      | DIP switches                                     |
| 7      | Ethernet terminal (see chapter 5.2.1)            |
| 8      | Option boards                                    |

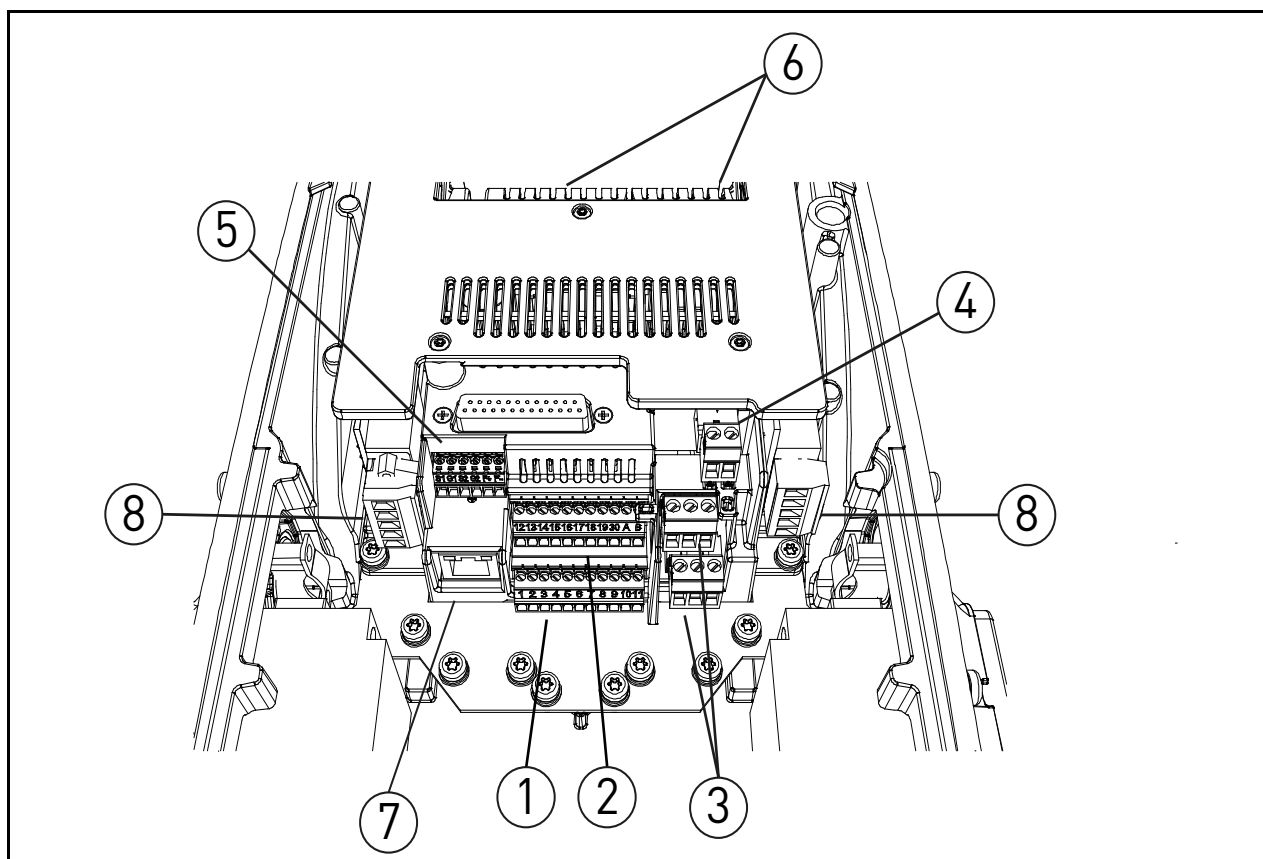

Figure 28. Locations of components in control unit

When delivered from the factory, the control unit of the AC drive contains the standard controlling interface - the control and relay terminals of the control unit - unless otherwise specifically ordered. On the next pages you will find the arrangement of the control I/O and the relay terminals, the general wiring diagram and the control signal descriptions.

The control board can be powered externally (+24VDC, max. 1000mA, ±10%) by connecting the external power source to terminal #30, see chapter 5.1.2. This voltage is sufficient for parameter setting and for keeping the control unit active. Note however that the measurements of the main circuit (e.g. DC-link voltage, unit temperature) are not available when the mains is not connected.

**5.1 CONTROL UNIT CABLING**

The principal terminal block placement is presented in Figure 29 below. The control board is equipped with 22 fixed control I/O terminals and the relay board with 6+2. Additionally, the terminals for the Safe Torque Off (STO) function (see chapter 9.) can be seen in the picture below. All signal descriptions are also given in Table 23.

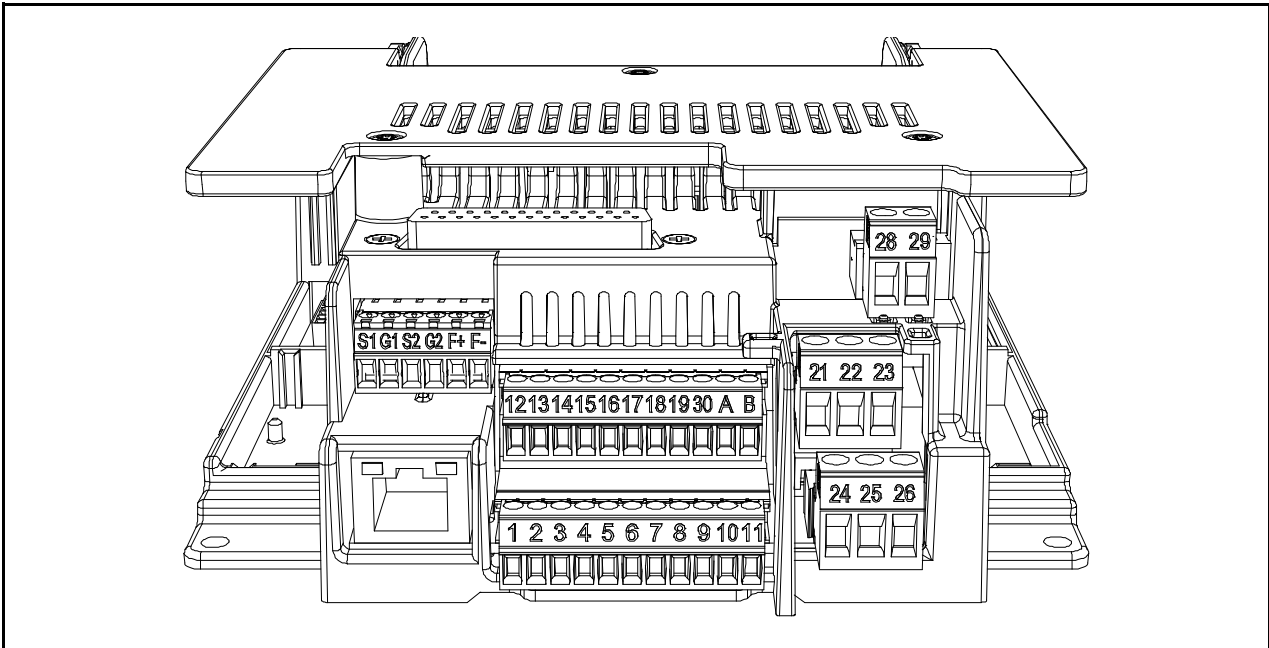

Figure 29. Control terminals

**5.1.1 CONTROL CABLE SIZING**

The control cables shall be at least 0.5 mm<sup>2</sup> screened multicore cables, see Table 22. The maximum terminal wire size is 2.5 mm<sup>2</sup> for the relay terminals and 1.5 mm<sup>2</sup> for other terminals.

Find the tightening torques of the control and relay board terminals in Table 22.

Table 22. Control cable tightening torques.

| Terminal screw                             | Tightening torque |         |
|--|-------------------|---------|
|  | Nm                | lb-in.  |
| I/O terminals and STO terminals (screw M2) | 0.22-0.25         | 2.0-2.2 |
| Relay terminals (screw M3)                 | 0.22-0.25         | 2.0-2.2 |

### 5.1.2 STANDARD I/O TERMINALS

The terminals of the *Standard I/Os* and the *Relays* are described below. For more information on the connections, see chapter 7.

The terminals shown on shadowed background are assigned for signals with optional functions selectable with DIP switches. See more information in chapter 5.1.5 and in chapter 5.1.6.

Table 23. Control I/O terminal signals and connection example.

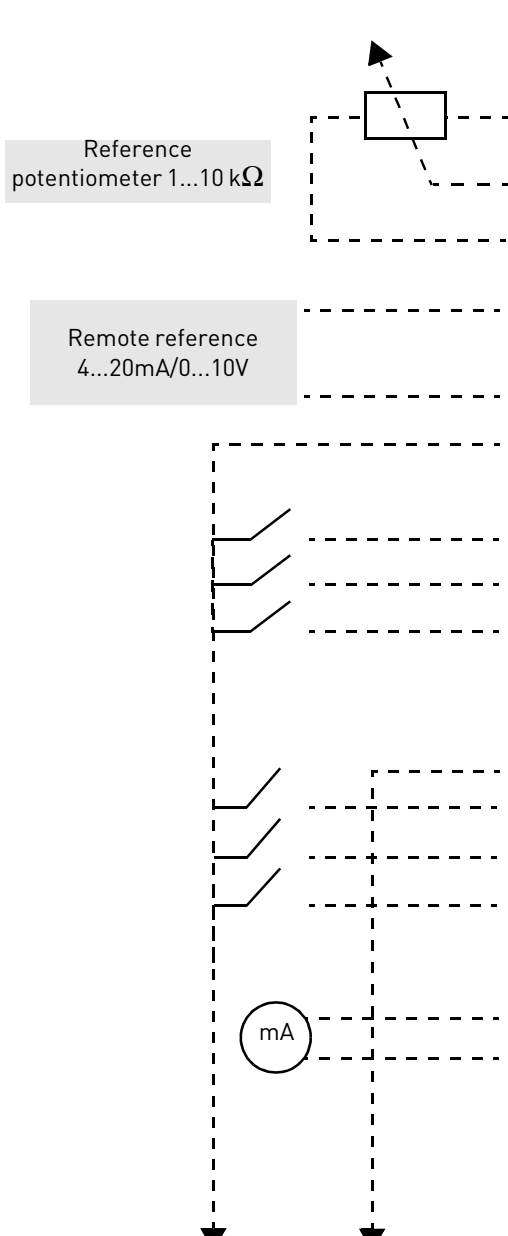

| Standard I/O |          |                                     |
|--------------|----------|-------------------------------------|
| Terminal     | Terminal | Signal                              |
| 1            | +10 Vref | Reference output                    |
| 2            | AI1+     | Analogue input, voltage or current  |
| 3            | AI1-     | Analogue input common               |
| 4            | AI2+     | Analogue input, voltage or current  |
| 5            | AI2-     | Analogue input common               |
| 6            | 24Vout   | 24V aux. voltage                    |
| 7            | GND      | I/O ground                          |
| 8            | DI1      | Digital input 1                     |
| 9            | DI2      | Digital input 2                     |
| 10           | DI3      | Digital input 3                     |
| 11           | CM       | Common for DI1-DI6*                 |
| 12           | 24Vout   | 24V aux. voltage                    |
| 13           | GND      | I/O ground                          |
| 14           | DI4      | Digital input 4                     |
| 15           | DI5      | Digital input 5                     |
| 16           | DI6      | Digital input 6                     |
| 17           | CM       | Common for DI1-DI6*                 |
| 18           | AO1+     | Analogue output, voltage or current |
| 19           | AO-/GND  | Analogue output common              |
| 30           | +24 Vin  | 24V auxiliary input voltage         |
| A            | RS485    | Serial bus, negative                |
| B            | RS485    | Serial bus, positive                |

\*. Can be isolated from ground, see chapter 5.1.6.

5.1.3 RELAY AND THERMISTOR INPUT TERMINALS

Table 24. I/O terminal signals for relay and thermistor terminals and connection example.

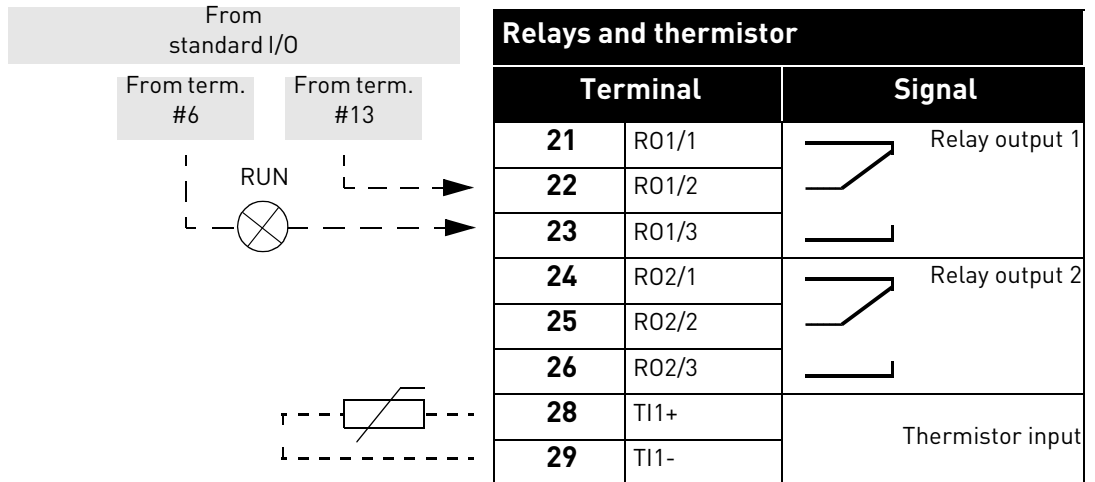

5.1.4 SAFE TORQUE OFF (STO) TERMINALS

For more information on the functionalities of the Safe Torque Off (STO), see chapter 9.

Table 25. I/O terminal signals for the STO functions.

| Safe Torque Off terminals |   |
|---------------------------|---|
| Terminal                  | Signal  |
| S1                        | Isolated digital input 1 (interchangeable polarity);<br>+24V ±20% 10...15mA |
| G1                        |   |
| S2                        | Isolated digital input 2 (interchangeable polarity);<br>+24V ±20% 10...15mA |
| G2                        |   |
| F+                        | Isolated feedback (CAUTION! Polarity to be respected);<br>+24V ±20%         |
| F-                        | Isolated feedback (CAUTION! Polarity to be respected);<br>GND               |



### 5.1.5 SELECTION OF TERMINAL FUNCTIONS WITH DIP SWITCHES

The VACON® 100 X drive embodies five so-called *DIP switches* that allow for three functional selections each. The shadowed terminals in Table 23 can be functionally modified with the DIP switches. The switches have three positions: C, 0 and V. The switch in the position “C” means that the input or the output has been set in current mode. The switch in the position “V” means voltage mode. The middle position “0” is for *Test mode*. See Figure 30 to locate the switches and make appropriate selections for your requirements. Factory defaults are: AI1 = V; AI2 = C, AO = C.

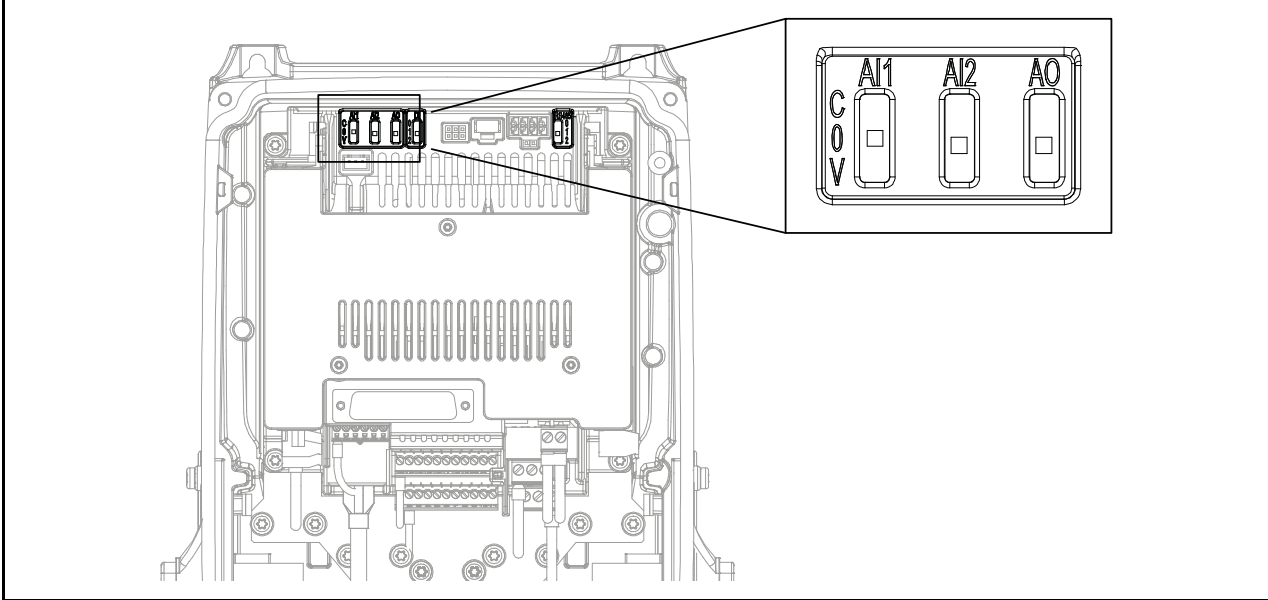

Figure 30. DIP switches for analogue inputs and analogue output

### 5.1.6 ISOLATING DIGITAL INPUTS FROM GROUND

The digital inputs (terminals 8-10 and 14-16) on the standard I/O board can be **isolated** from ground by setting the *DIP switch* to position ‘0’. The switch in the position “1” means that the common of digital input has been connected to 24 V (negative logic). The switch in the position “2” means that the common of digital inputs has been connected to ground (positive logic). See Figure 31. Locate the switch and set it in desired position. Factory default is 2.

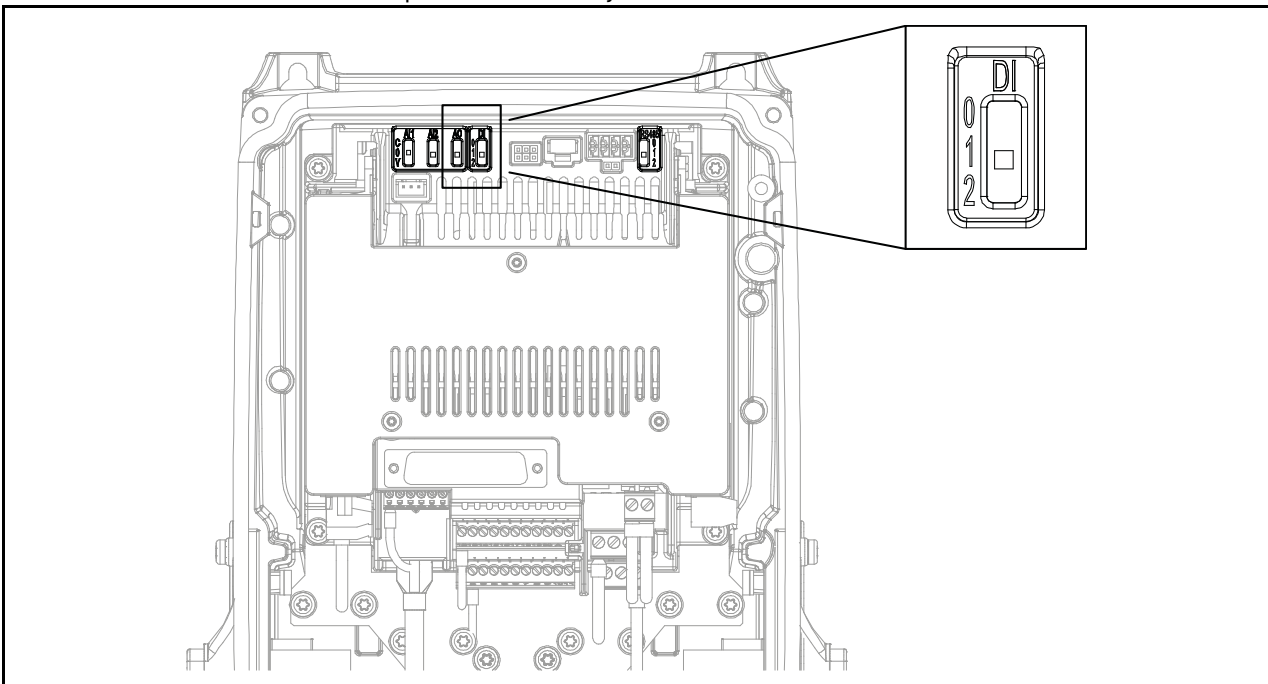

Figure 31. Digital inputs DIP switch

### 5.1.7 BUS TERMINATION OF THE RS485 CONNECTION

This DIP switch is related to the RS485 connection. It is used for bus termination. The bus termination must be set to the first and to the last device on the network. This switch in position "0" means that a termination resistor of 120 ohm is connected and the termination of the bus has been set. This switch in the position "1" means that a pull-up and a pull-down resistors of 10 kOhm have been connected for biasing purpose. The switch in the position "2" means no termination and no biasing resistors have been connected. Factory default is 2. See Figure 32.

In case other termination or biasing values are needed, use the advanced connector. Biasing resistors (for example 390 ohm) can be connected between terminals 1 (+5V) to 2 (RS485\_A) and 3 (RS485\_B) to 4(GND). Termination resistor (for example 220 ohm) can be connected between terminals 2 (RS485\_A) to 3 (RS485\_B). When the advanced connector is used, the DIP switch must be set to "2".

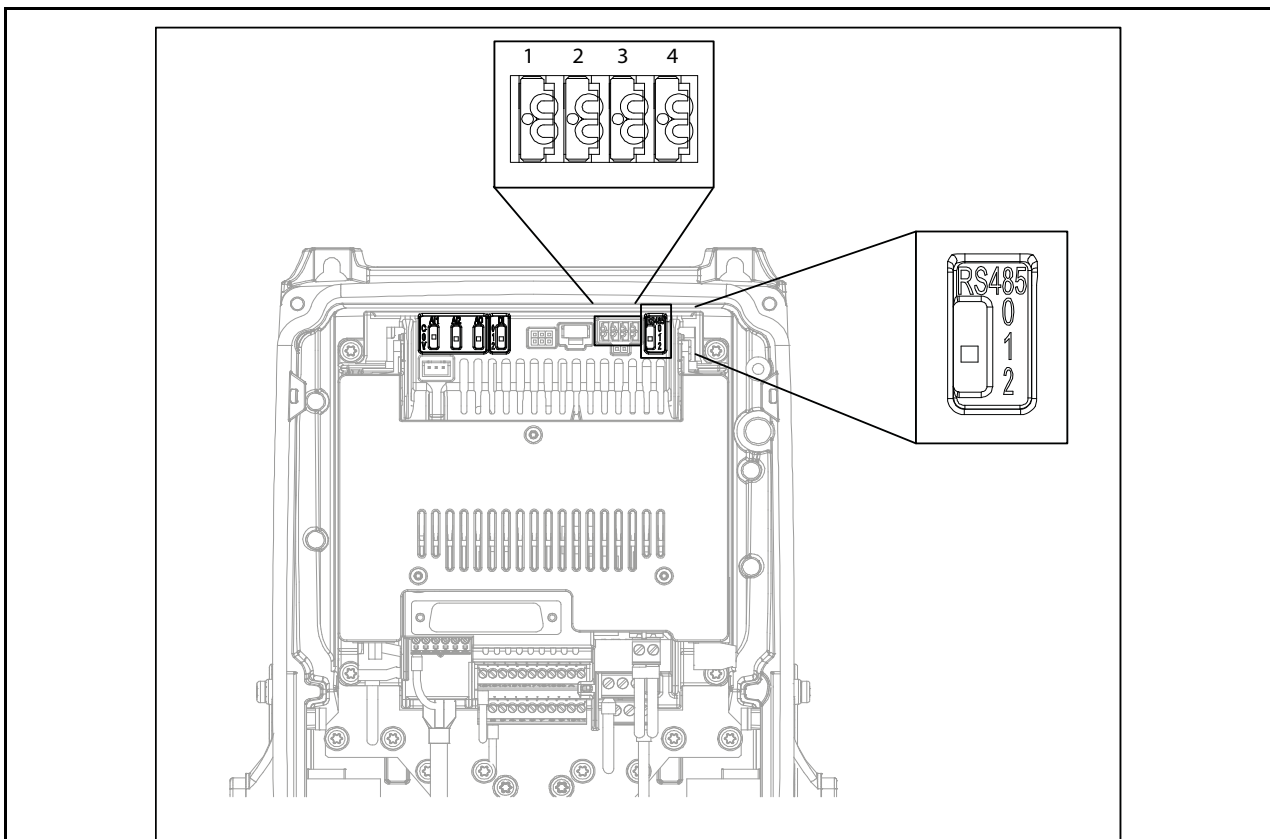

Figure 32. RS485 DIP switch and advanced connector

## 5.2 I/O CABLING AND FIELDBUS CONNECTION

The AC drive can be connected to fieldbus either through RS485 or Ethernet. The connection for RS485 is on the standard I/O terminals (A and B) and the connection for Ethernet is left to the control terminals. See Figure 33.

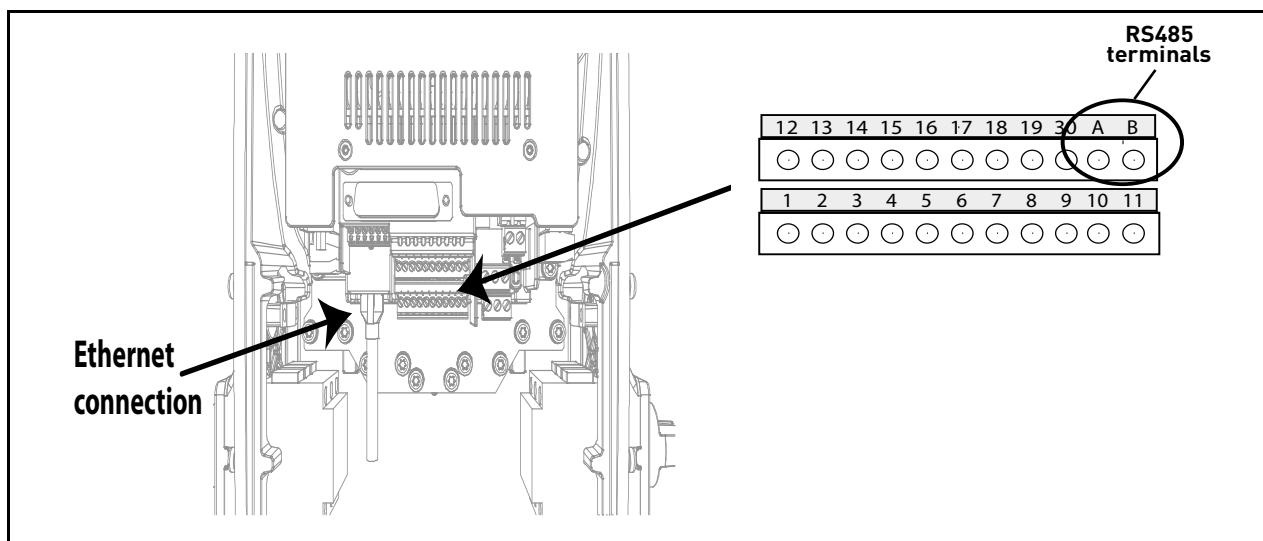

Figure 33.

### 5.2.1 PREPARE FOR USE THROUGH ETHERNET

|          |  |
|----------|--|
| <b>1</b> | Connect the Ethernet cable (see specification on page 51) to its terminal and run the cable through the conduit plate.   |
| <b>2</b> | Remount the powerhead. <b>NOTE:</b> When planning the cable runs, remember to keep the distance between the Ethernet cable and the motor cable at a <b>minimum of 30 cm.</b> |

For more detailed information, see the user’s manual of the fieldbus you are using.

#### 5.2.1.1 Ethernet cable data

Table 26. Ethernet cable data.

|              |   |
|--------------|---|
| Connector    | Shielded RJ45 connector. Note: max length of the connector 40 mm. |
| Cable type   | CAT5e STP   |
| Cable length | Max. 100m   |

5.2.2 PREPARE FOR USE THROUGH RS485

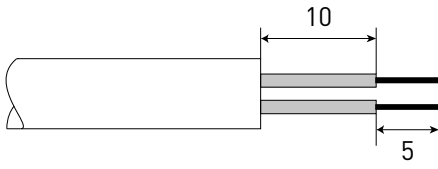
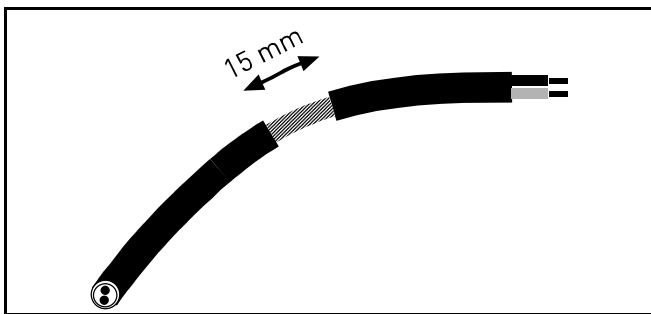
|          |  |
|----------|--|
| <b>1</b> | <p>Strip about 15 mm of the RS485 cable (see specification on page 53) and cut off the grey cable shield. Remember to do this for both bus cables (except for the last device).</p> <p>Leave no more than 10 mm of the cable outside the terminal block and strip the cables at about 5 mm to fit in the terminals. See picture below.</p> <div style="text-align: center;">  </div> <p>Also strip the cable now at such a distance from the terminal that you can fix it to the frame with the grounding clamp. Strip the cable at a maximum length of 15 mm. <b>Do not strip the aluminum cable shield!</b></p> <div style="text-align: center;">  </div> |
|----------|--|

|          |  |
|----------|--|
| <b>2</b> | <p>Then connect the cable to its appropriate terminals on VACON® 100 X AC drive standard terminal block, terminals <b>A and B</b> (A = negative, B = positive). See Figure 33.</p> |
|----------|--|

|          |  |
|----------|--|
| <b>3</b> | <p>Using the cable clamp included in the delivery of the drive, ground the shield of the RS485 cable to the frame of the AC drive.</p> |
|----------|--|

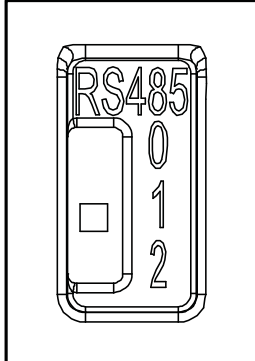
|          |   |
|----------|---|
| <b>4</b> | <p><b>If VACON® 100 X AC drive is the last device on the bus</b>, the bus termination must be set. Locate the DIP switches to the top of the control unit (see Figure 32) and turn the right most switch to position "0". This setting creates a 120 ohm termination. In case something else is needed and/or biasing is needed, use the advanced connector to add external resistors (see Figure 32). See also step 6.</p> <div style="text-align: right;">  </div> |
|----------|---|

|          |  |
|----------|--|
| <b>5</b> | <p><b>NOTE:</b> When planning the cable runs, remember to keep the distance between the fieldbus cable and the motor cable at a <b>minimum of 30 cm</b>.</p> |
|----------|--|

6

The bus termination must be set for the first and the last device of the fieldbus line. See picture below and step 4. We recommend that the first device on the bus and, thus, terminated, was the Master device.

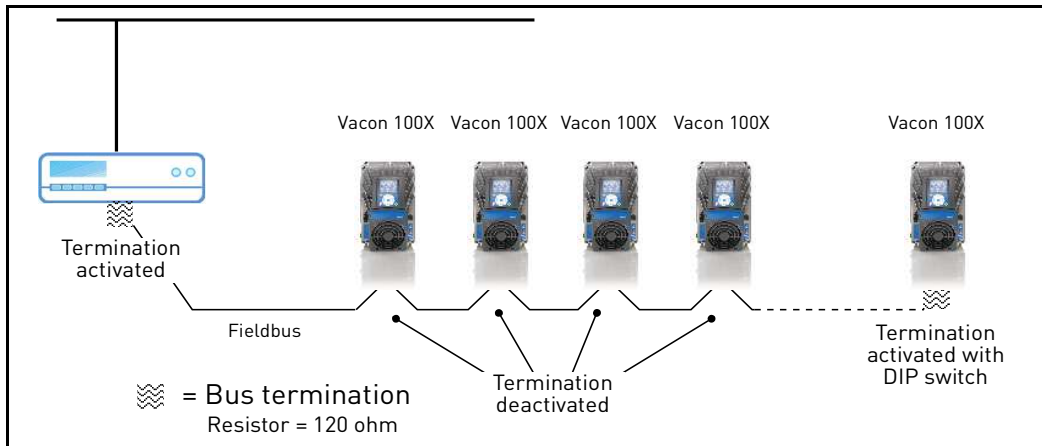

5.2.3 RS485 CABLE DATA

Table 27. RS485 cable data.

|              |  |
|--------------|--|
| Connector    | 2.5 mm <sup>2</sup>                                      |
| Cable type   | STP (Shielded Twisted Pair), type Belden 9841 or similar |
| Cable length | Depends on the used fieldbus. See respective bus manual. |

### 5.3 BATTERY INSTALLATION FOR REAL TIME CLOCK (RTC)

Enabling the functions of the Real Time Clock (RTC) requires that an optional battery is installed in the VACON® 100 X drive.

Detailed information on the functions of the *Real Time Clock (RTC)* can be found in the Application Manual. See the following figures to install the battery on the control box of VACON® 100 X AC drive.

**1**

Remove the three screws on the control box as shown in Figure 34.

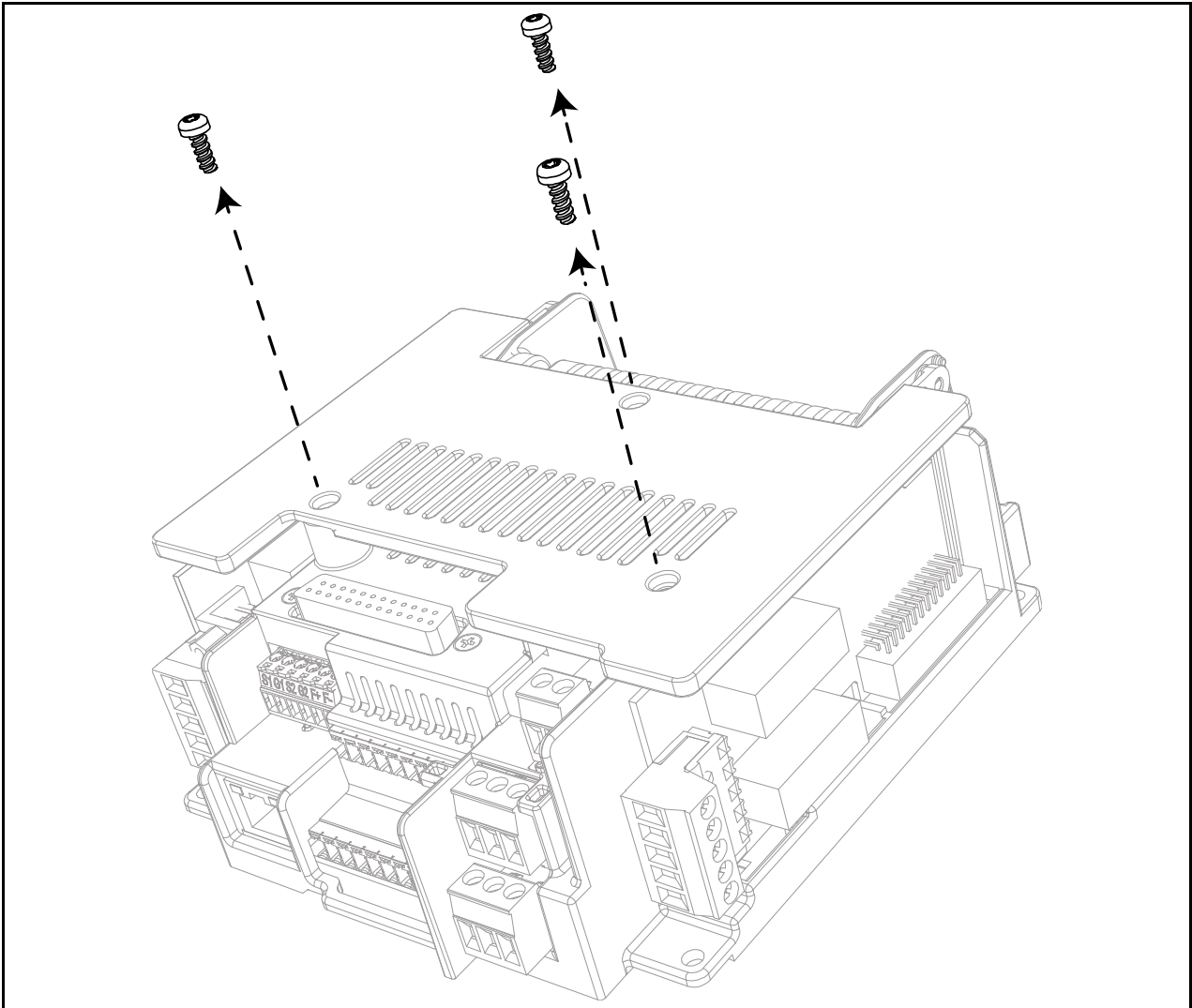

Figure 34. Remove the three screws on the control box

**2**

Rotate and open the cover of the control box as shown in Figure 35.

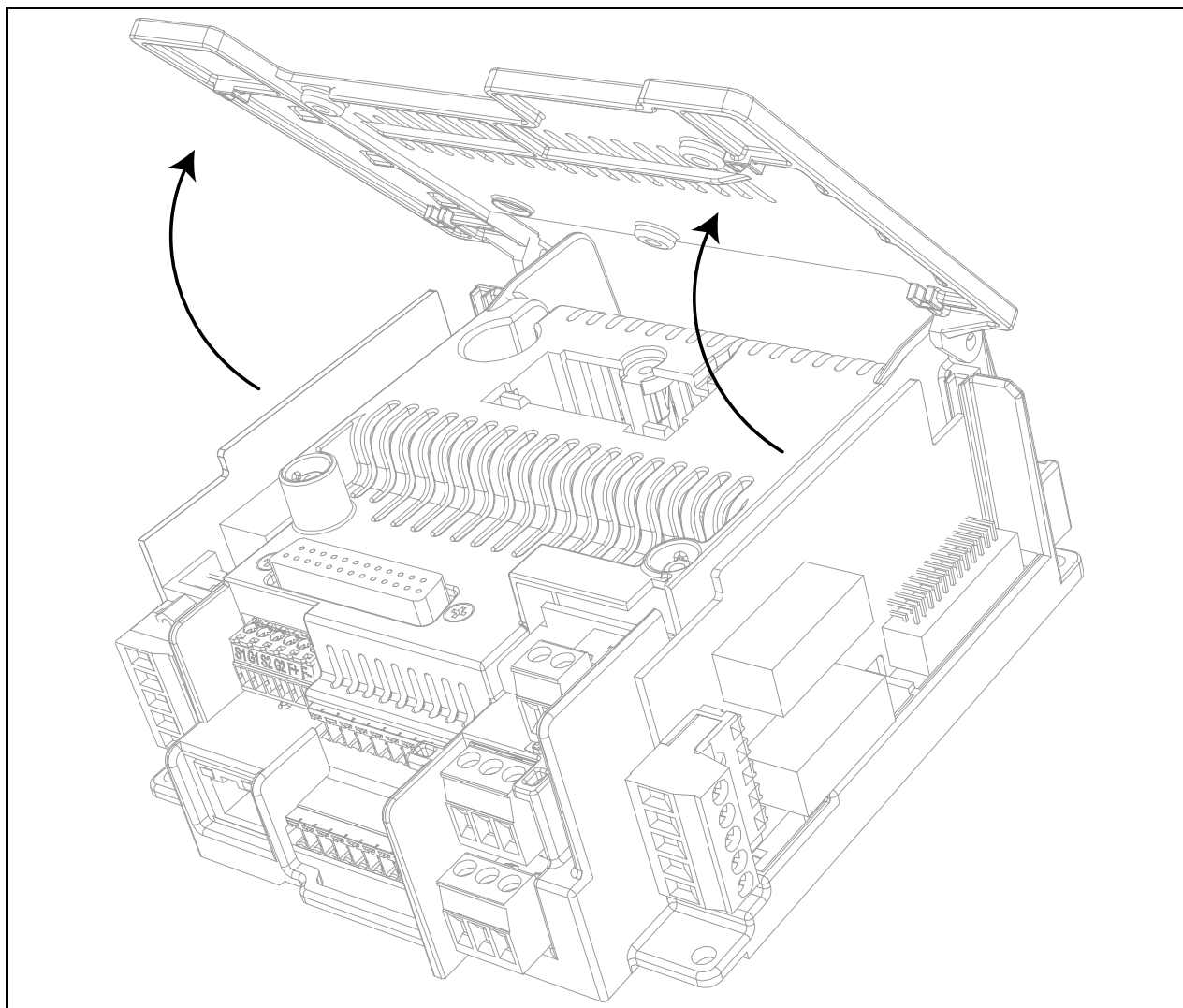

Figure 35. Open the cover of control box

**3**

Install the battery in the correct place and connect it to the control box. See Figure 36 for battery location and connector.

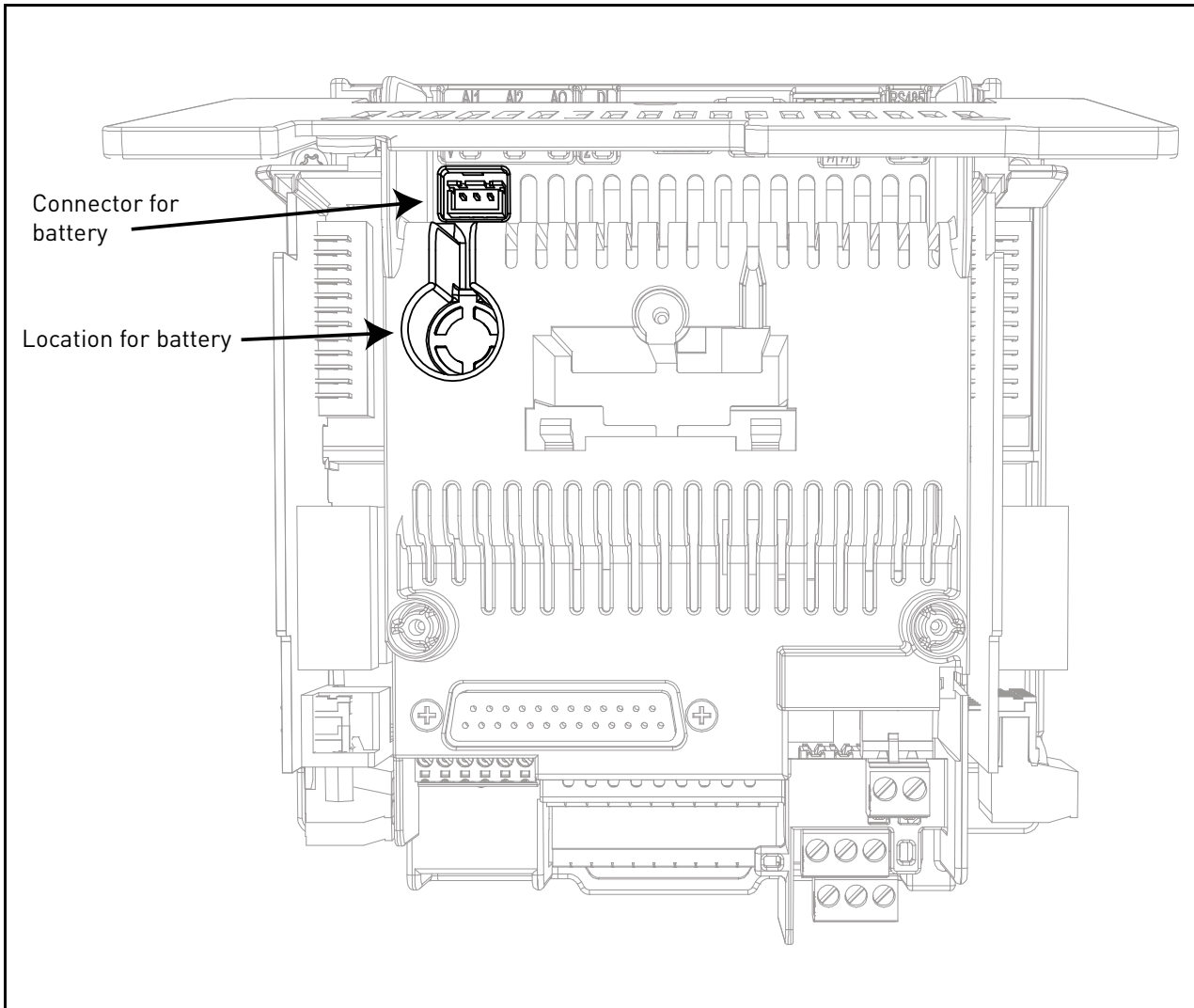

Figure 36. Location and connector for the battery on the control box



## 6. COMMISSIONING

Before commissioning, note the following directions and warnings:



Internal components and circuit boards of VACON® 100 X drive (except for the galvanically isolated I/O terminals) are live when it is connected to the mains potential. **Coming into contact with this voltage is extremely dangerous and may cause death or severe injury.**



The motor terminals **U, V, W** and the brake resistor terminals **R-/R+** are live when VACON® 100 X drive is connected to the mains, **even if the motor is not running.**



The control I/O-terminals are isolated from the mains potential. However, the **relay outputs and other I/O-terminals may have a dangerous control voltage** present even when VACON® 100 X drive is disconnected from the mains.



Do not make any connections to or from the AC drive when it is connected to the mains.



**After disconnecting** the AC drive from the mains, **wait** until the fan stops and the indicators on the powerhead go out. Wait an additional 30 seconds before doing any work on the connections of VACON® 100 X Drive. Do not open the unit before this time has expired. After expiration of this time, use a measuring equipment to absolutely ensure that no voltage is present. **Always ensure absence of voltage before starting any electrical work!**



**Before connecting** the AC drive to mains make sure that the powerhead VACON® 100 X Drive is mounted firmly on the terminal box.

## 6.1 COMMISSIONING OF THE DRIVE

Read carefully the safety instructions in Chapter 1 and above and follow them.

After the installation:

|                          |   |
|--------------------------|---|
| <input type="checkbox"/> | Check that both the AC drive and the motor are grounded.  |
| <input type="checkbox"/> | Check that the mains and motor cables comply with the requirements given in chapter 5.  |
| <input type="checkbox"/> | Check that the control cables are located as far as possible from the power cables.   |
| <input type="checkbox"/> | Check that the shields of the shielded cables are connected to protective earth marked with  . |
| <input type="checkbox"/> | Check the tightening torques of all terminals.  |
| <input type="checkbox"/> | Check that the wires do not touch the electrical components of the drive.   |
| <input type="checkbox"/> | Check that the common inputs of digital input groups are connected to +24V or ground of the I/O terminal.   |
| <input type="checkbox"/> | Check the quality and quantity of cooling air.  |
| <input type="checkbox"/> | Check the inside of the AC drive for condensation.  |
| <input type="checkbox"/> | Check that all Start/Stop switches connected to the I/O terminals are in the Stop-position.   |
| <input type="checkbox"/> | Before connecting the AC drive to mains: Check mounting and condition of all fuses and other protective devices.  |
| <input type="checkbox"/> | Run the Startup Wizard (see the Application Manual).  |

### 6.2 CHANGING EMC PROTECTION CLASS

If your supply network is an IT (impedance-grounded) system but your AC drive is EMC-protected according to class C1 or C2 you need to modify the EMC protection of the AC drive to EMC-level T (C4). This is done by removing the EMC screws as described below:

|  |   |
|--|---|
|  | Warning! Do not perform any modifications on the AC drive when it is connected to mains.  |
|  | Do not remove the EMC screws in the solar pump application. IT (impedance-grounded) AC supply network is not allowed in the solar pump application. |

|          |  |
|----------|--|
| <b>1</b> | Separate the powerhead and the terminal box. Turn the powerhead upside down and remove the two screws marked in Figure 37 (for MM4), Figure 38 (for MM5) and in Figure 40 (for MM6). |
|----------|--|

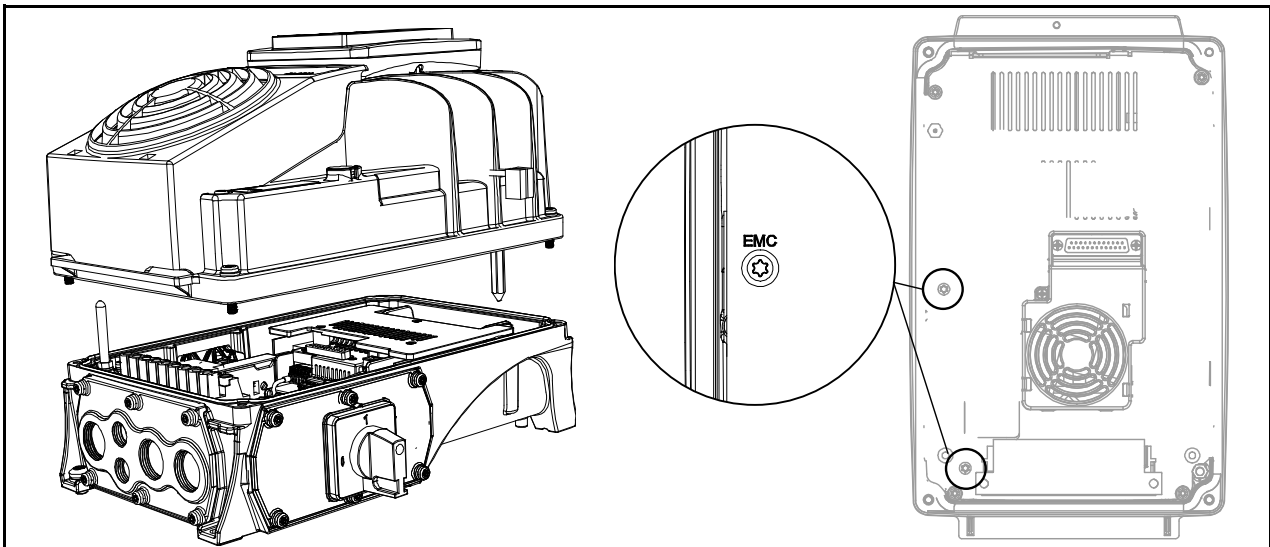

Figure 37. Locations of EMC screws in MM4

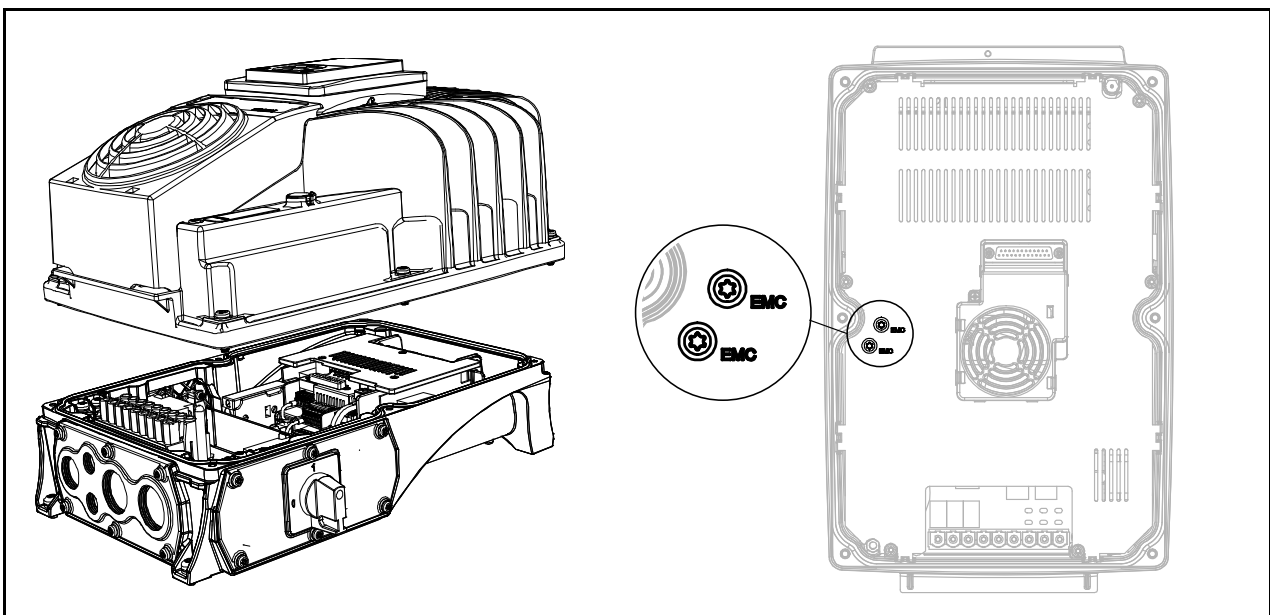

Figure 38. Locations of EMC screws in MM5

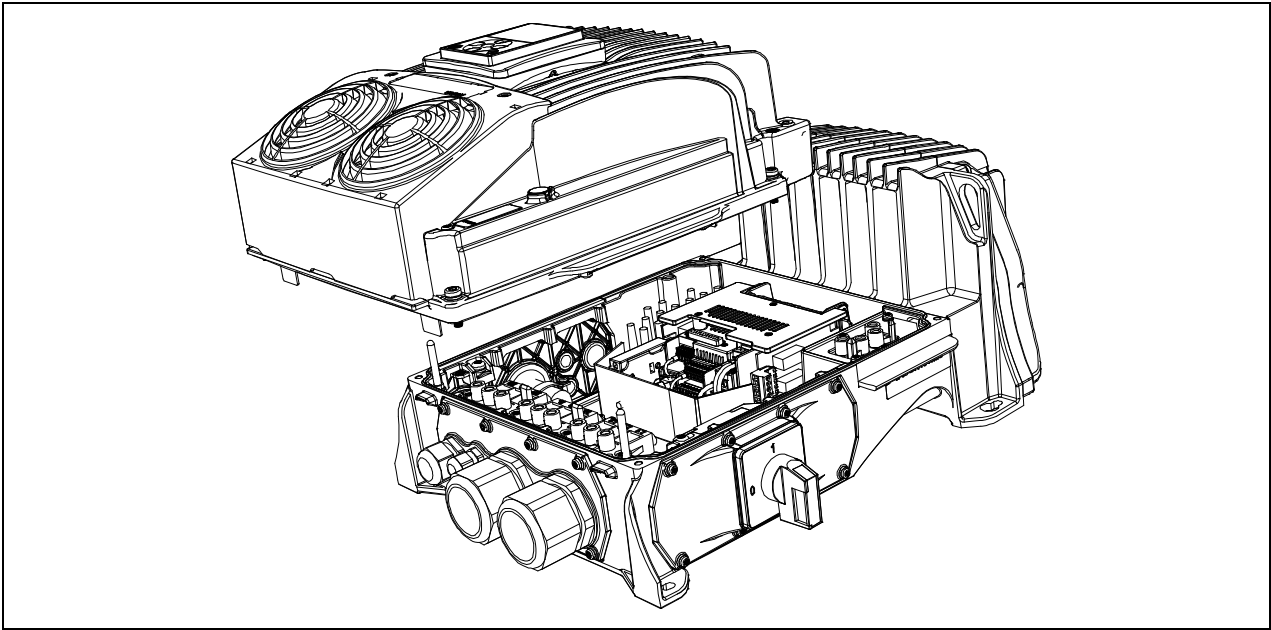

Figure 39. Powerhead separated from the terminal box in MM6

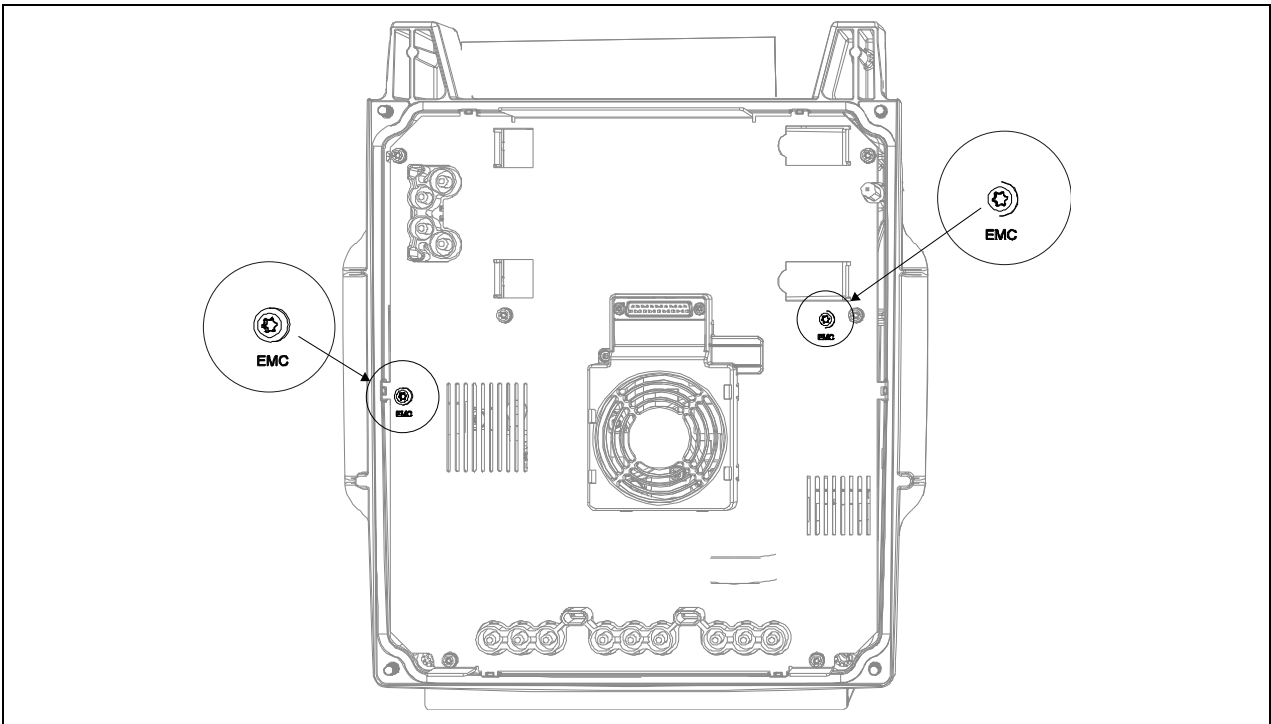



Figure 40. Locations of EMC screws in MM6

**2**

**CAUTION!** Before connecting the AC drive to mains make sure that the EMC protection class settings of the drive are appropriately made.

3

**NOTE!** After having performed the change write 'EMC level modified' on the sticker included in the VACON® 100 X delivery (see below) and note the date. Unless already done, attach the sticker close to the name plate of the AC drive.

| Product modified          |  |
|---------------------------|--|
| Date: .....               |  |
| Date: .....               |  |
| EMC-level modified C1->C4 | Date: DDMMYY  |

### 6.3 RUNNING THE MOTOR

#### MOTOR RUN CHECK LIST



**Before starting the motor**, check that the motor is **mounted properly** and ensure that the machine connected to the motor allows the motor to be started.



Set the maximum motor speed (frequency) according to the motor and the machine connected to it.



**Before reversing the motor** make sure that this can be done safely.



Make sure that no power correction capacitors are connected to the motor cable.



Make sure that the motor terminals are not connected to mains potential.

#### 6.3.1 CABLE AND MOTOR INSULATION CHECKS

- Motor cable insulation checks  
Disconnect the motor cable from terminals U, V and W of the AC drive and from the motor. Measure the insulation resistance of the motor cable between each phase conductor as well as between each phase conductor and the protective ground conductor. The insulation resistance must be  $>1\text{M}\Omega$  at ambient temperature of  $20^\circ\text{C}$ .
- Mains cable insulation checks  
Disconnect the mains cable from terminals L1, L2 and L3 of the AC drive and from the mains. Measure the insulation resistance of the mains cable between each phase conductor as well as between each phase conductor and the protective ground conductor. The insulation resistance must be  $>1\text{M}\Omega$  at ambient temperature of  $20^\circ\text{C}$ .
- Motor insulation checks  
Disconnect the motor cable from the motor and open the bridging connections in the motor connection box. Measure the insulation resistance of each motor winding. The measurement voltage must equal at least the motor nominal voltage but not exceed 1000 V. The insulation resistance must be  $>1\text{M}\Omega$  at ambient temperature of  $20^\circ\text{C}$ .

#### 6.3.2 MOTOR OVERLOAD PROTECTION

On VACON® 100 X, the motor temperature can be measured with sensors in the motor or be calculated by the electronic motor overload protection. The AC drive provides an input for an external

temperature sensor, which must be embedded in the motor. This is a standard feature of VACON® 100 X.

The electronic motor overload protection is based on a temperature model and algorithms to estimate the motor temperature from the operating conditions. The internal electronic motor overload protection implemented in VACON® 100 X has thermal memory retention and speed sensitivity.

According to EN 61800-5-1:2007/A1:2017, the electronic motor overload protection shall comply with Table 28.

Table 28. Multiplier values for current settings

| Multiplier                                 | Maximum trip time |
|--|-------------------|
| 7.2 (trip at a lower overload could occur) | 20 s              |
| 1.5  | 8 min             |
| 1.2  | 2 h               |

To guarantee a thermal protection in accordance with the standard, set the following parameters for VACON® 100 X.

Table 29. Parameter settings

| Index    | Parameter                | Description   | Value |
|----------|--------------------------|---|-------|
| P3.9.2.6 | MotorThermMemoryAdjust   | The estimated temperature rise is added to a motor ambient temperature set by the parameter P3.9.2.2 MotAmbientTemp.<br>0 = Disabled<br>1 = Constant<br>2 = Last value<br>3 = Real time clock | 100   |
| P3.9.2.4 | Motor Thermal Time Const | The time constant is the time within which the calculated thermal stage has reached 63% of its final value  | 3     |

For more parameters related to the motor overload protection, see the Application Manual.



Internal motor overload protection operates at 105% of the motor full load current.



Instruct the AC drives with nominal motor current (full load current according to the motor technical label) in order to use the protection properly.



Parameters other than those previously described may not be changed. If further parameters related to the motor overload protection are changed, the protection function of the motor model can no longer be guaranteed.



The thermal model cannot protect the motor in the event of incorrect installation or parameter assignment. Follow the instructions for installation and commissioning.

---

## 6.4 MAINTENANCE

In normal conditions, the AC drive is maintenance-free. However, regular maintenance is recommended to ensure trouble-free operation and longevity of the drive. We recommend the table below is followed for maintenance intervals.

**NOTE:** Because of capacitor type (thin film capacitors), reforming of capacitors is not necessary.

| Maintenance interval                                    | Maintenance action   |
|---|--|
| Regularly and according to general maintenance interval | <ul style="list-style-type: none"> <li>• Check the tightening torques of terminals.</li> </ul>   |
| 6...24 months (depending on environment)                | <ul style="list-style-type: none"> <li>• Check the input and output terminals and the control I/O terminals.</li> <li>• Check the operation of the cooling fan.</li> <li>• Clean the fan and the fan housing if necessary.</li> <li>• Check the heatsink for dust, and clean it if necessary.</li> </ul> |
| 6...20 years  | <ul style="list-style-type: none"> <li>• Change the main fan.</li> </ul>   |
| 10 years  | <ul style="list-style-type: none"> <li>• Replace the battery of the RTC.</li> </ul>  |



## 7. TECHNICAL DATA

### 7.1 AC DRIVE POWER RATINGS

#### 7.1.1 MAINS VOLTAGE 3AC 208-240V

Table 30. Power ratings of VACON® 100 X, supply voltage 3AC 208-240V.

| Mains voltage 3AC 208-240V, 50/60 Hz |               |                   |   |                          |                            |                   |             |
|--------------------------------------|---------------|-------------------|---|--------------------------|----------------------------|-------------------|-------------|
|                                      | AC drive type | Input current [A] | Loadability                                 |                          |                            | Motor shaft power |             |
|                                      |               |                   | Rated continuous current I <sub>N</sub> [A] | 50% overload current [A] | Max current I <sub>S</sub> | 230V supply       |             |
|                                      |               |                   |   |                          |                            | [kW]              | [HP]        |
| <b>MM4</b>                           | 0006          | 6.0               | <b>6.6</b>                                  | 9.9                      | 13.2                       | <b>1.1</b>        | <b>1.5</b>  |
|                                      | 0008          | 7.2               | <b>8.0</b>                                  | 12.0                     | 16.0                       | <b>1.5</b>        | <b>2.0</b>  |
|                                      | 0011          | 9.7               | <b>11.0</b>                                 | 16.5                     | 22.0                       | <b>2.2</b>        | <b>3.0</b>  |
|                                      | 0012          | 10.9              | <b>12.5</b>                                 | 18.8                     | 25.0                       | <b>3.0</b>        | <b>4.0</b>  |
| <b>MM5</b>                           | 0018          | 16.1              | <b>18.0</b>                                 | 27.0                     | 36.0                       | <b>4.0</b>        | <b>5.0</b>  |
|                                      | 0024          | 21.7              | <b>24.2</b>                                 | 36.3                     | 48.4                       | <b>5.5</b>        | <b>7.5</b>  |
|                                      | 0031          | 27.7              | <b>31.0</b>                                 | 46.5                     | 62.0                       | <b>7.5</b>        | <b>10.0</b> |
| <b>MM6</b>                           | 0048          | 43.8              | <b>48.0</b>                                 | 72.0                     | 96.0                       | <b>11.0</b>       | <b>15.0</b> |
|                                      | 0062          | 57.0              | <b>62.0</b>                                 | 93.0                     | 124.0                      | <b>15.0</b>       | <b>20.0</b> |

**NOTE:** The rated currents in given ambient temperatures (in Table 30) are achieved only when the switching frequency is equal to or less than the factory default.

7.1.2 MAINS VOLTAGE 3AC 380-480/500V

Table 31. Power ratings of VACON® 100 X, supply voltage 3AC 380-480/500V, high overload.

| Mains voltage 3AC 380-480/500V, 50/60 Hz |               |                   |   |                          |                            |                   |             |
|--|---------------|-------------------|---|--------------------------|----------------------------|-------------------|-------------|
|  | AC drive type | Input current [A] | Loadability                                 |                          |                            | Motor shaft power |             |
|  |               |                   | Rated continuous current I <sub>N</sub> [A] | 50% overload current [A] | Max current I <sub>S</sub> | 400V              | 480V        |
|  |               |                   |   |                          |                            | [kW]              | [HP]        |
| <b>MM4</b>                               | 0003          | 3.4               | <b>3.4</b>                                  | 5.1                      | 6.8                        | <b>1.1</b>        | <b>1.5</b>  |
|  | 0004          | 4.6               | <b>4.8</b>                                  | 7.2                      | 9.6                        | <b>1.5</b>        | <b>2.0</b>  |
|  | 0005          | 5.4               | <b>5.6</b>                                  | 8.4                      | 11.2                       | <b>2.2</b>        | <b>3.0</b>  |
|  | 0008          | 8.1               | <b>8.0</b>                                  | 12.0                     | 16.0                       | <b>3.0</b>        | <b>5.0</b>  |
|  | 0009          | 9.3               | <b>9.6</b>                                  | 14.4                     | 19.2                       | <b>4.0</b>        | <b>5.0</b>  |
|  | 0012          | 11.3              | <b>12.0</b>                                 | 18.0                     | 24.0                       | <b>5.5</b>        | <b>7.5</b>  |
| <b>MM5</b>                               | 0016          | 15.4              | <b>16.0</b>                                 | 24.0                     | 32.0                       | <b>7.5</b>        | <b>10.0</b> |
|  | 0023          | 21.3              | <b>23.0</b>                                 | 34.5                     | 46.0                       | <b>11.0</b>       | <b>15.0</b> |
|  | 0031          | 28.4              | <b>31.0</b>                                 | 46.5                     | 62.0                       | <b>15.0</b>       | <b>20.0</b> |
| <b>MM6</b>                               | 0038          | 36.7              | <b>38.0</b>                                 | 57.0                     | 76.0                       | <b>18.5</b>       | <b>25.0</b> |
|  | 0046          | 43.6              | <b>46.0</b>                                 | 69.0                     | 92.0                       | <b>22.0</b>       | <b>30.0</b> |
|  | 0061          | 58,2              | <b>61.0</b>                                 | 91.5                     | 122.0                      | <b>30.0</b>       | <b>40.0</b> |

Table 32. Power ratings of VACON® 100 X, supply voltage 3AC 380-480/500V, low overload.

| Mains voltage 3AC 380-480/500V, 50/60 Hz |               |                   |   |                          |                            |                   |             |
|--|---------------|-------------------|---|--------------------------|----------------------------|-------------------|-------------|
|  | AC drive type | Input current [A] | Loadability                                 |                          |                            | Motor shaft power |             |
|  |               |                   | Rated continuous current I <sub>N</sub> [A] | 10% overload current [A] | Max current I <sub>S</sub> | 400V              | 480V        |
|  |               |                   |   |                          |                            | [kW]              | [HP]        |
| <b>MM6</b>                               | 0072          | 67.5              | <b>72.0</b>                                 | 80.0                     | 108.0                      | <b>37.0</b>       | <b>50.0</b> |

**NOTE:** The rated currents in given ambient temperatures (in Table 31 and Table 32) are achieved only when the switching frequency is equal to or less than the factory default.

7.1.3 DEFINITIONS OF OVERLOADABILITY

**High overload**= Following continuous operation at rated output current  $I_N$ , the drive supplies  $150\% \cdot I_N$  for 1 min, followed by a period of at least 9 min at  $I_N$  or below.

Example: If the duty cycle requires  $150\%$  rated current for 1 min in every 10 min, the remaining 9 min must be at rated current  $I_N$  or less.

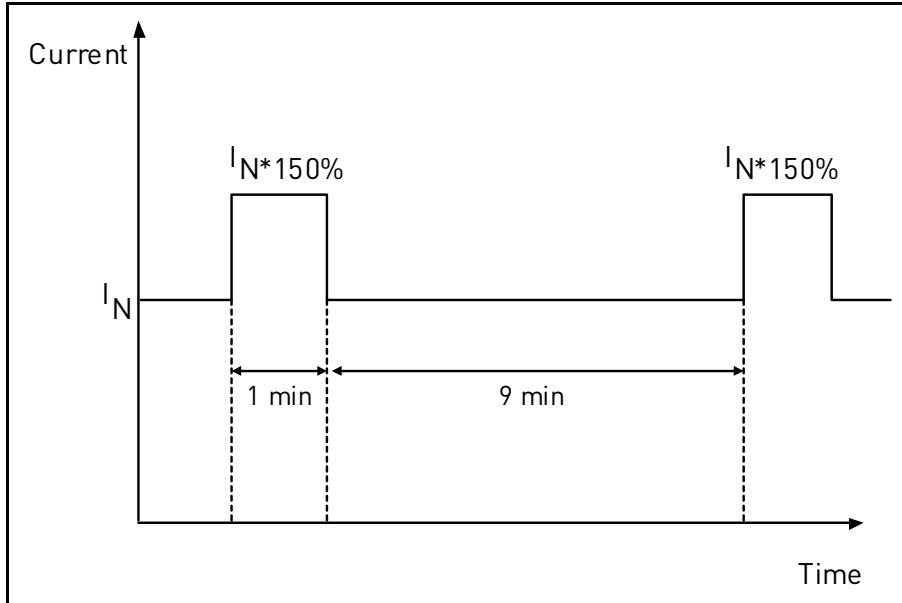

Figure 41. High overload

**Low overload**= Following continuous operation at rated output current  $I_N$ , the drive supplies  $110\% \cdot I_N$  for 1 min, followed by a period of at least 9 min at  $I_N$  or below.

Example: If the duty cycle requires  $110\%$  rated current for 1 min in every 10 min, the remaining 9 min must be at rated current  $I_N$  or less.

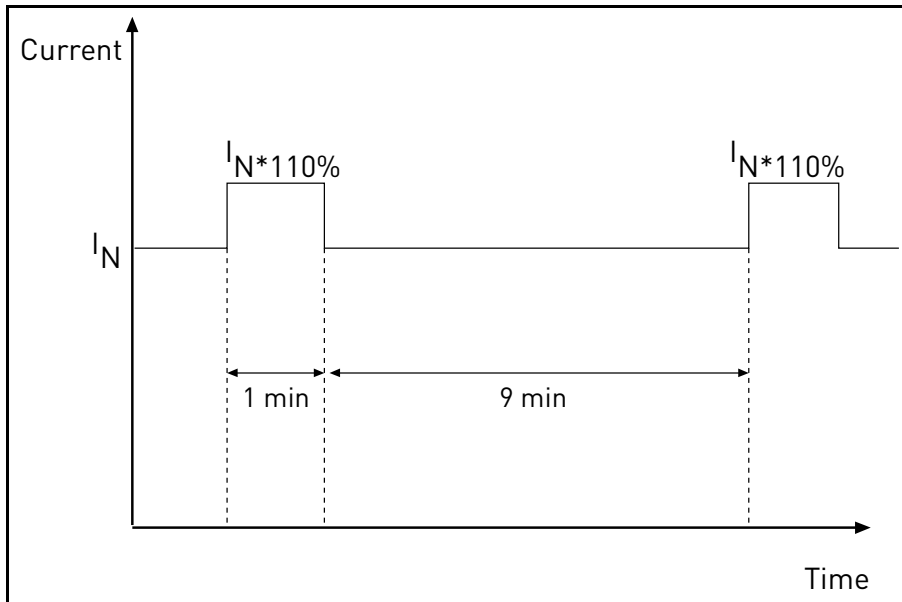

Figure 42. Low overload

**NOTE!** For more information, refer to IEC61800-2 (IEC:1998) Standard.

## 7.2 BRAKE RESISTOR RATINGS

Make sure that the resistance is higher than the minimum resistance defined. The power handling capacity must be sufficient for the application.

Recommended minimum brake resistor values for VACON® 100 X AC drives:

Table 33. Brake resistor ratings, 208-240V.

| Mains Voltage 3AC 208-240V, 50/60 Hz |      |                                      |                           |
|--------------------------------------|------|--------------------------------------|---------------------------|
| Enclosure size                       | Type | Minimum Resistance recommended [ohm] | Brake power @405 VDC [kW] |
| MM4                                  | 0006 | 25                                   | 6.6                       |
|                                      | 0008 | 25                                   | 6.6                       |
|                                      | 0011 | 25                                   | 6.6                       |
|                                      | 0012 | 25                                   | 6.6                       |
| MM5                                  | 0018 | 15                                   | 10.9                      |
|                                      | 0024 | 15                                   | 10.9                      |
|                                      | 0031 | 10                                   | 16.4                      |
| MM6                                  | 0048 | 8                                    | 20.5                      |
|                                      | 0062 | 8                                    | 20.5                      |

Table 34. Brake resistor ratings, 380-480/500V.

| Mains Voltage 3AC 380-480/500V, 50/60 Hz |      |                                      |                           |
|--|------|--------------------------------------|---------------------------|
| Enclosure size                           | Type | Minimum Resistance recommended [ohm] | Brake power @845 VDC [kW] |
| MM4                                      | 0003 | 50                                   | 14.3                      |
|  | 0004 | 50                                   | 14.3                      |
|  | 0005 | 50                                   | 14.3                      |
|  | 0008 | 50                                   | 14.3                      |
|  | 0009 | 50                                   | 14.3                      |
|  | 0012 | 50                                   | 14.3                      |
| MM5                                      | 0016 | 30                                   | 23.8                      |
|  | 0023 | 30                                   | 23.8                      |
|  | 0031 | 20                                   | 35.7                      |
| MM6                                      | 0038 | 15                                   | 47.6                      |
|  | 0046 | 15                                   | 47.6                      |
|  | 0061 | 15                                   | 47.6                      |
|  | 0072 | 15                                   | 47.6                      |

## 7.3 VACON® 100 X - TECHNICAL DATA

Table 35. VACON® 100 X technical data.

|                         |  |  |
|-------------------------|--|--|
| <b>Mains connection</b> | Input voltage $U_{in}$                     | 3 AC 208...240 V<br>3 AC 380...480 V<br>3 AC 380...500 V   |
|                         | Input voltage tolerance                    | -15%...+10%  |
|                         | Input frequency                            | 50/60 Hz   |
|                         | Protection class                           | I  |
|                         | Input frequency tolerance                  | 47.5...66 Hz   |
|                         | Connection to mains                        | Once per minute or less  |
|                         | Starting delay                             | <7 s   |
|                         | Supply network                             | TN- and IT-network (cannot be used with corner earthed network)  |
|                         | Short-circuit current                      | Max. short-circuit current has to be < 100 kA (with optional mains switch < 5 kA)                                    |
| <b>DC connection</b>    | Input Voltage $U_{DC}$ :                   | 234 ... 400 VDC<br>436 ... 800 VDC<br><br>Input voltage tolerance: No tolerance permissible, 0%                      |
|                         |  |  |
| <b>Motor connection</b> | Output voltage                             | 3 AC 0... $U_{in}$   |
|                         | Rated output current                       | $I_N$ : Ambient temperature max. +40°C. See Table 30, Table 31 and Table 32.   |
|                         | Overload output current                    | 1.5 x $I_N$ (1 min/10 min);<br>1.1 x $I_N$ (1 min/10 min) only for MM6 0072.<br>See Table 30, Table 31 and Table 32. |
|                         | Starting output current                    | $I_S$ for 2 s every 20 s.<br>See Table 30, Table 31 and Table 32.  |
|                         | Output frequency                           | 0...320 Hz (standard)  |
|                         | Frequency resolution                       | 0.01 Hz  |
|                         | Protection class                           | I  |
|                         | Motor characteristics                      | AC squirrel cage motors<br>Permanent magnet motors<br>Synchronous Reluctance Motors                                  |
|                         | Cable type                                 | Screened motor cable   |
|                         | Cable maximum length (full EMC compliance) | C2: 5 m  |

Table 35. VACON® 100 X technical data.

|                                |  |   |
|--------------------------------|--|---|
| <b>Control characteristics</b> | Switching frequency                                      | Programmable 1.5...16 kHz;<br>Default: 6 kHz (MM4 and MM5); 4 kHz (MM6)<br>Automatic switching frequency derating in case of overheating                            |
|                                | Frequency reference<br>Analogue input<br>Panel reference | Resolution 0.1% (10-bit), accuracy $\pm 1\%$<br>Resolution 0.01 Hz  |
|                                | Field weakening point                                    | 8...320 Hz  |
|                                | Acceleration time  | 0.1...3000 s  |
|                                | Deceleration time  | 0.1...3000 s  |
|                                | Braking  | Brake chopper standard in all frames<br>External brake resistor optional  |
| <b>Control connections</b>     | See chapter 5.   |   |
| <b>Communication interface</b> | Fieldbus   | Standard: Serial communication (RS485/Modbus); EtherNet/IP, PROFINET IO, Modbus TCP, BACnet IP<br>Optional: CANOpen; PROFIBUS DP, DeviceNet, LonWorks, AS-interface |
|                                | Status indicators  | Drive status indicators (LED) on top side (POWER, RUN, FAULT, READY)  |
| <b>Ambient conditions</b>      | Ambient operating temperature                            | -10°C ...+40°C  |
|                                | Extended temperature range                               | up to 60°C with current derating (see chapter 1.8)  |
|                                | Storage temperature                                      | -40°C...+70°C   |
|                                | Relative humidity  | 0 to 100% R <sub>H</sub>  |
|                                | Pollution degree   | PD2 used for PCB design.<br>However the drives are suitable for outdoor use because of dust-tight enclosure to numeral 6 [acc. to IEC 60529].                       |
|                                | Altitude   | 100% load capacity (no derating) up to 1,000m;<br>derating 1%/100m at 1,000...3,000m  |
|                                | Stationary vibration:<br>sinusoidal                      | 3 Hz $\leq$ f $\leq$ 8.72 Hz: 10 mm<br>8.72 Hz $\leq$ f $\leq$ 200 Hz: 3g<br>[3M7 acc. to IEC 60721-3-3]  |
|                                | Shock/Bump   | 25g / 6 ms<br>[3M7 acc. to IEC 60721-3-3]   |
|                                | Degree of protection                                     | IP66/Type 4X  |
| <b>Noise Level</b>             | Average noise level (min-max) in dB (A)                  | The sound pressure depends on the cooling fan speed, which is controlled in accordance with the drive temperature.<br>MM4: 45-56<br>MM5: 57-65<br>MM6: 63-72        |

Table 35. VACON® 100 X technical data.

|                                  |  |   |
|----------------------------------|--|---|
| <b>Directives</b>                | EMC  | 2014/30/EU  |
|                                  | Low Voltage Directive  | 2014/35/EU  |
|                                  | RoHS   | 2011/65/EU, amended 2015/863/EU   |
|                                  | WEEE   | 2012/19/EU  |
| <b>Standards</b>                 | Immunity   | EN61800-3, 1 <sup>st</sup> and 2 <sup>nd</sup> environment  |
|                                  | Emissions  | EN61800-3, Category C2<br>The drive can be modified for IT-networks.  |
|                                  | THD  | EN61000-3-12 (see chapter 1.9)  |
|                                  | Safety   | EN 61800-5-1  |
| <b>Production quality</b>        | ISO 9001   |   |
| <b>Approvals</b>                 | Functional Safety  | TÜV - Tested  |
|                                  | Electrical Safety  | TÜV - Tested  |
|                                  | EMC  | TÜV - Tested  |
|                                  | USA, Canada  | cULus approval, file number E171278   |
| <b>Declaration of Conformity</b> | Korea  | KC mark   |
|                                  | Australia  | RCM Declaration of Conformity<br>Registration number E2204  |
|                                  | Europe   | EC Declaration of Conformity  |
| <b>Protections</b>               | Undervoltage trip limit                                      | Depends on supply voltage (0.8775*supply voltage):<br>Supply voltage 240 V: Trip limit <b>211 V</b><br>Supply voltage 400 V: Trip limit <b>351 V</b><br>Supply voltage 480 V: Trip limit <b>421 V</b> |
|                                  | Overtoltage fault protection                                 | Yes   |
|                                  | Earth fault protection                                       | Yes   |
|                                  | Mains supervision  | Yes   |
|                                  | Motor phase supervision                                      | Yes   |
|                                  | Overcurrent protection                                       | Yes   |
|                                  | Unit overtemperature protection                              | Yes   |
|                                  | Motor overload protection                                    | Yes. These devices provide motor overload protection at 105% of full load amperes.  |
|                                  | Motor stall protection                                       | Yes   |
|                                  | Motor underload protection                                   | Yes   |
|                                  | Short-circuit protection of +24V and +10V reference voltages | Yes   |
|                                  | Thermal motor protection                                     | Yes (by PTC)  |
|                                  | DC-link absolute maximum voltage                             | Supply voltage 240 V: absolute maximum 450 V <sub>DC</sub><br>Supply voltage 400 V: 900 V <sub>DC</sub>   |

## 7.3.1 TECHNICAL INFORMATION ON CONTROL CONNECTIONS

Table 36. Technical information on standard I/O terminals.

| Standard I/O |                                     |   |
|--------------|-------------------------------------|---|
| Terminal     | Signal                              | Technical information   |
| 1            | Reference output                    | +10V, +3%; Maximum current 10 mA  |
| 2            | Analogue input, voltage or current  | Analogue input channel 1<br>0-20 mA ( $R_i = 250 \Omega$ )<br>0-10 V ( $R_i = 200k\Omega$ )<br>Resolution 0.1%, accuracy $\pm 1\%$<br>Selection V/mA with DIP switches (see chapter 5).<br>Default 0-10V<br>Short-circuited protected.  |
| 3            | Analogue input common               | Differential input if not connected to ground;<br>Allows $\pm 20V$ differential mode voltage to GND   |
| 4            | Analogue input, voltage or current  | Analogue input channel 2<br>0-20 mA ( $R_i = 250 \Omega$ )<br>0-10 V ( $R_i = 200k\Omega$ )<br>Resolution 0.1%, accuracy $\pm 1\%$<br>Selection V/mA with DIP switches (see chapter 5).<br>Default 0-20mA<br>Short-circuited protected. |
| 5            | Analogue input common               | Differential input if not connected to ground;<br>Allows 20V differential mode voltage to GND   |
| 6            | 24V aux. voltage                    | +24V, $\pm 10\%$ , max volt. ripple < 100mVrms; max. 250mA<br>Short-circuit protected   |
| 7            | I/O ground                          | Ground for reference and controls (connected internally to frame earth through $1M\Omega$ )   |
| 8            | Digital input 1                     | Positive or negative logic<br>$R_i = \text{min. } 5k\Omega$<br>18...30V = "1"<br>0...5V = "0"   |
| 9            | Digital input 2                     |   |
| 10           | Digital input 3                     |   |
| 11           | Common A for DIN1-DIN6.             | Digital inputs can be isolated from ground, see chapter 5.<br>Default: connected to ground.   |
| 12           | 24V aux. voltage                    | Same as terminal 6.   |
| 13           | I/O ground                          | Ground for reference and controls (connected internally to frame earth through $1M\Omega$ )   |
| 14           | Digital input 4                     | Positive or negative logic<br>$R_i = \text{min. } 5k\Omega$<br>18...30V = "1"<br>0...5V = "0"   |
| 15           | Digital input 5                     |   |
| 16           | Digital input 6                     |   |
| 17           | Common A for DIN1-DIN6.             | Digital inputs can be isolated from ground, see chapter 5.<br>Default: connected to ground.   |
| 18           | Analogue output, voltage or current | Analogue output channel 1<br>0-20 mA ( $R_L < 500 \Omega$ )<br>0-10 V ( $R_L > 1k\Omega$ )<br>Resolution 0.1%, accuracy $\pm 2\%$<br>Selection V/mA with DIP switches (see chapter 5).<br>Default 0-20mA<br>Short-circuited protected.  |
| 19           | Analogue output common              |   |
| 30           | 24V auxiliary input voltage         | Can be used with an external power supply (with a current limiter or fuse protected) to supply the control unit and fieldbus for backup purposes.<br>Dimensioning: max. 1000mA/control unit.  |



Table 36. Technical information on standard I/O terminals.

| Standard I/O |        |   |
|--------------|--------|---|
| Terminal     | Signal | Technical information   |
| A            | RS485  | Differential receiver/transmitter<br>Set bus termination with DIP switches (see page 49).<br>Default: but termination disconnected. |
| B            | RS485  |   |

Table 37. Technical information on Relay and thermistor terminals.

| Relays   |                  |  |
|--|------------------|--|
| Relays with two change-over contact (SPDT) and a PTC thermistor input.<br>5.5 mm isolation between channels. |                  |  |
| Terminal   | Signal           | Technical information                        |
| 21   | Relay output 1*  | Switching capacity                           |
| 22   |                  | 24VDC/8A                                     |
| 23   |                  | 250VAC/8A<br>125VDC/0.4A                     |
| 24   | Relay output 2*  | Min.switching load                           |
| 25   |                  | 5V/10mA                                      |
| 26   |                  | Switching capacity                           |
| 28   | Thermistor input | 24VDC/8A                                     |
| 29   |                  | 250VAC/8A<br>125VDC/0.4A                     |
|  |                  | Min.switching load                           |
|  |                  | 5V/10mA                                      |
|  |                  | Rtrip = 4.7 kΩ (PTC); Measuring voltage 3.5V |

\* If 230VAC is used as control voltage from the output relays, the control circuitry must be powered with a separate isolation transformer to limit short circuit current and overvoltage spikes. This is to prevent welding on the relay contacts. Refer to standard EN 60204-1, section 7.2.9

## 8. OPTIONS

The options available for VACON® 100 X are described below.

### 8.1 MAINS SWITCH

The mains switch can be used for service or urgency stop. The purpose of the mains switch is to disconnect the VACON® 100 X from the mains when, for example, service actions are needed. The mains switch color is red/yellow. The mains switch is available as option and it can be integrated in the drive. The mains switch can be mounted on either side of the drive. See Figure 43.

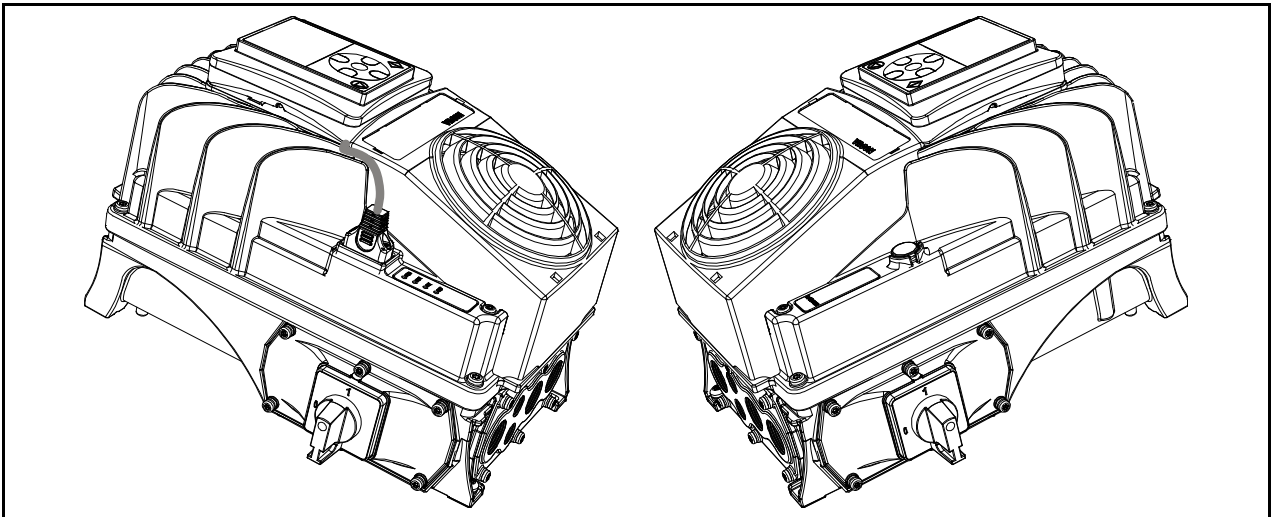

Figure 43. The mains switch mounted on either side of the drive, MM4 example

**NOTE!** If the cULus mark is required, the use of the optional mains switch is not allowed with the models 0062-2, 0061-4, 0061-5, 0072-4, and 0072-5, unless current derating is applied. The input current cannot exceed 52 A at 30°C ambient temperature and 45 A at 40°C ambient temperature.

**NOTE!** Mains switch only for AC voltage. Do not use for DC voltage.

**NOTE!** Braided cable types recommended for mains switch cabling.

Table 38. Order codes for VACON® 100 X Mains Switch

| Order code    | Description                         | Option type  |
|---------------|-------------------------------------|--------------|
| POW-QDSS-MM04 | VACON®100 X MM4 Mains Switch Option | Loose Option |
| POW-QDSS-MM05 | VACON®100 X MM5 Mains Switch Option | Loose Option |
| POW-QDSS-MM06 | VACON®100 X MM6 Mains Switch Option | Loose Option |

8.1.1 INSTALLATION

- |          |   |
|----------|---|
| <b>1</b> | <ul style="list-style-type: none"> <li>Remove the cable entry plate from the drive on the left-hand-side if the mains switch must be mounted on this side. Otherwise remove the cable entry plate from the right-hand-side. See the Figure 44.</li> </ul> |
|----------|---|

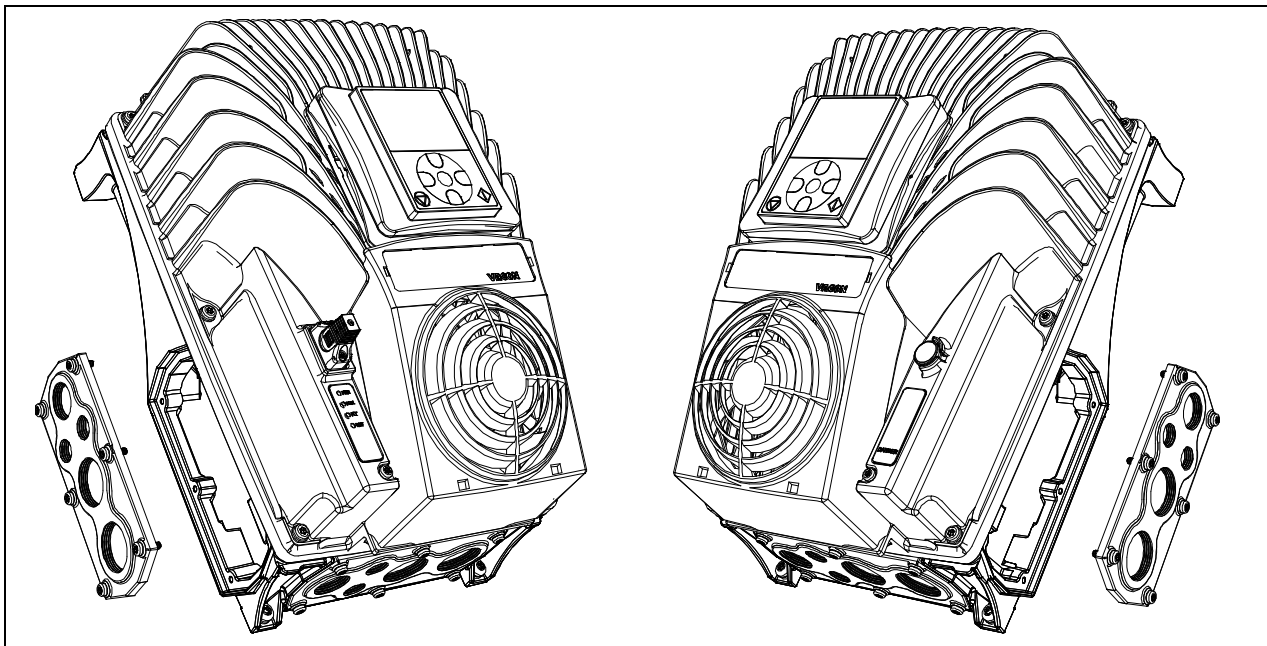

Figure 44. Disconnect the cable entry plate: example for MM5

- |          |   |
|----------|---|
| <b>2</b> | <ul style="list-style-type: none"> <li>Remove the cable entry plate from the bottom side of the terminal box by loosening the six screws. Cables pass through this inlet hole.</li> </ul> |
|----------|---|

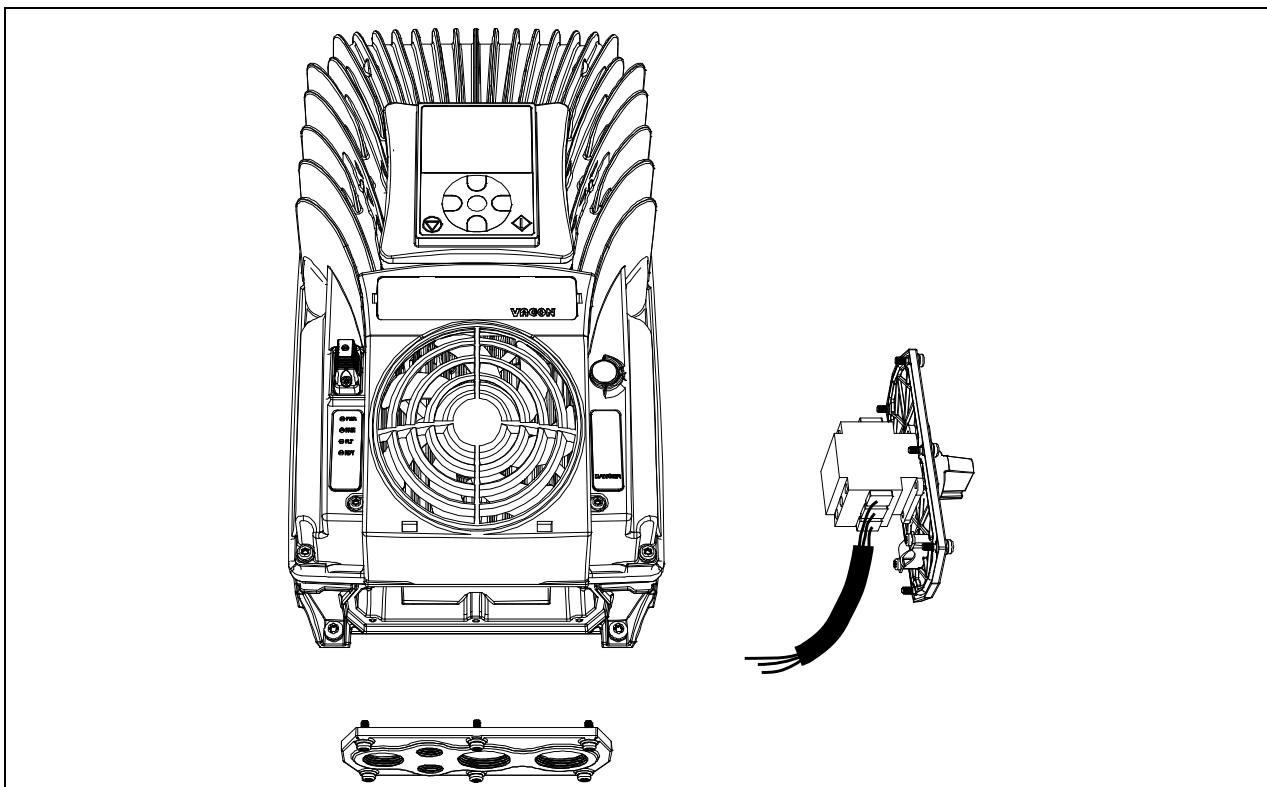

Figure 45. Cable entry plate from the bottom side of the drive

**3**

- Remove the powerhead from the terminal box by loosening the screws on the top side of the drive.

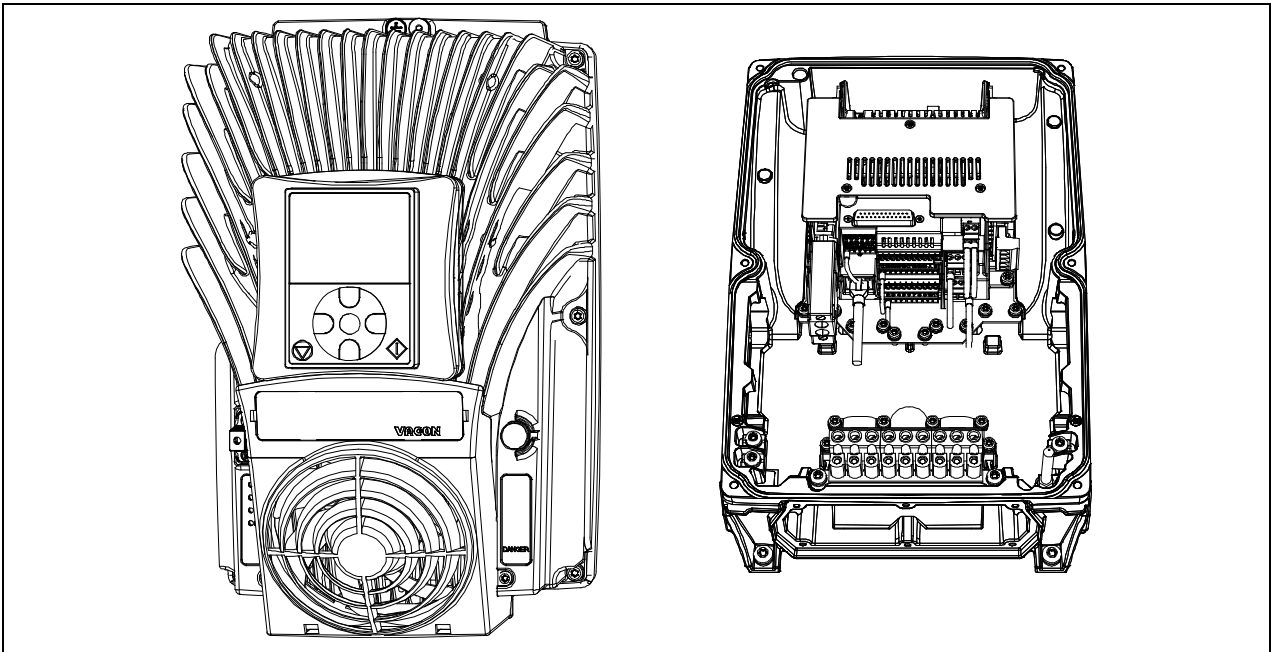

Figure 46. Powerhead separated from the terminal box

**4**

- Connect the supply cable to the Mains switch passing through the cable entry plate of the bottom side (use the cable gland for sealing the cable to the gland plate) and then through the terminal box as shown in the figure below.

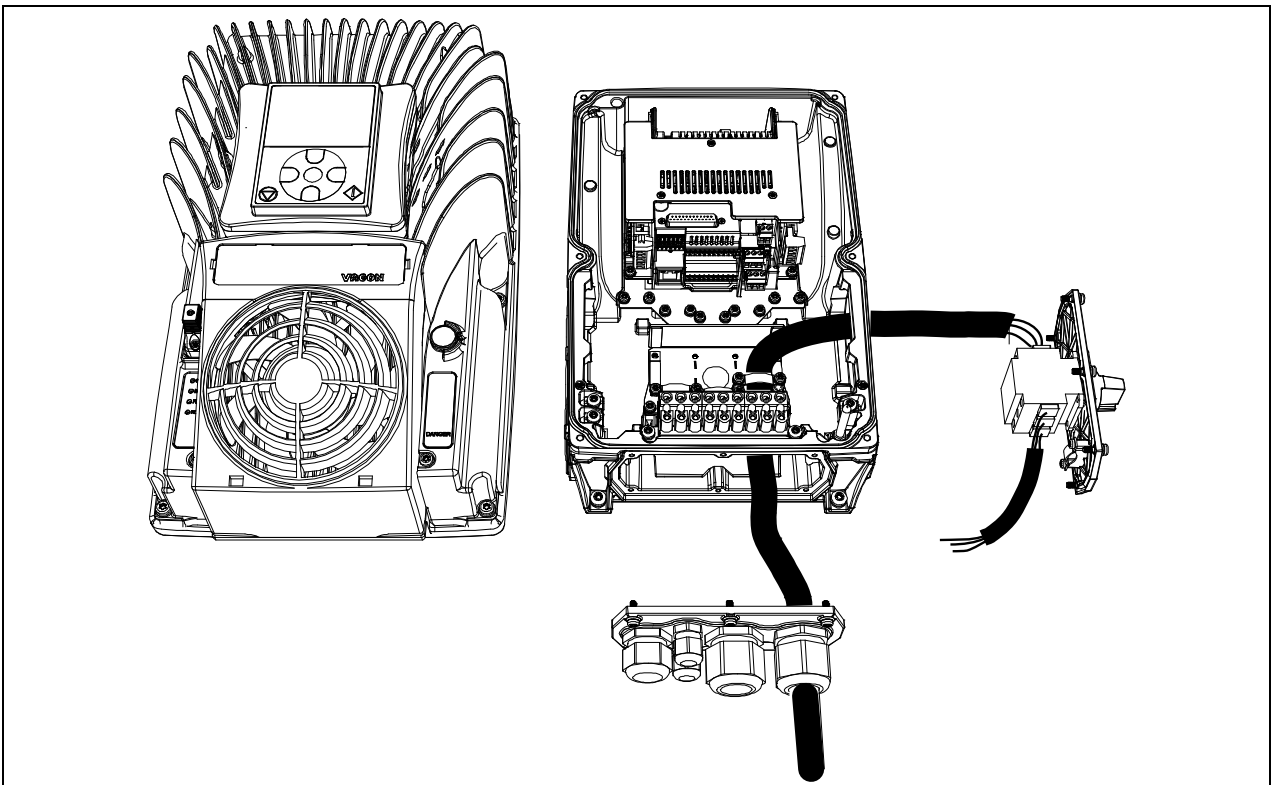

Figure 47. Connection of the supply cable to the Mains switch (right-hand-side example)

|          |  |
|----------|--|
| <b>5</b> | <ul style="list-style-type: none"> <li>Connect the cables from the Mains switch to the terminal box. The cables have to be connected to the terminals L1, L2 and L3.</li> </ul>                                      |
| <b>6</b> | <ul style="list-style-type: none"> <li>Place the Mains switch plate with the cables in the groove and fix it with its screws.</li> </ul>   |
| <b>7</b> | <ul style="list-style-type: none"> <li>Place the cable entry plate with the other cables (motor cable, brake cable, I/O cables) in the groove on the bottom side of the drive and fix it with its screws.</li> </ul> |

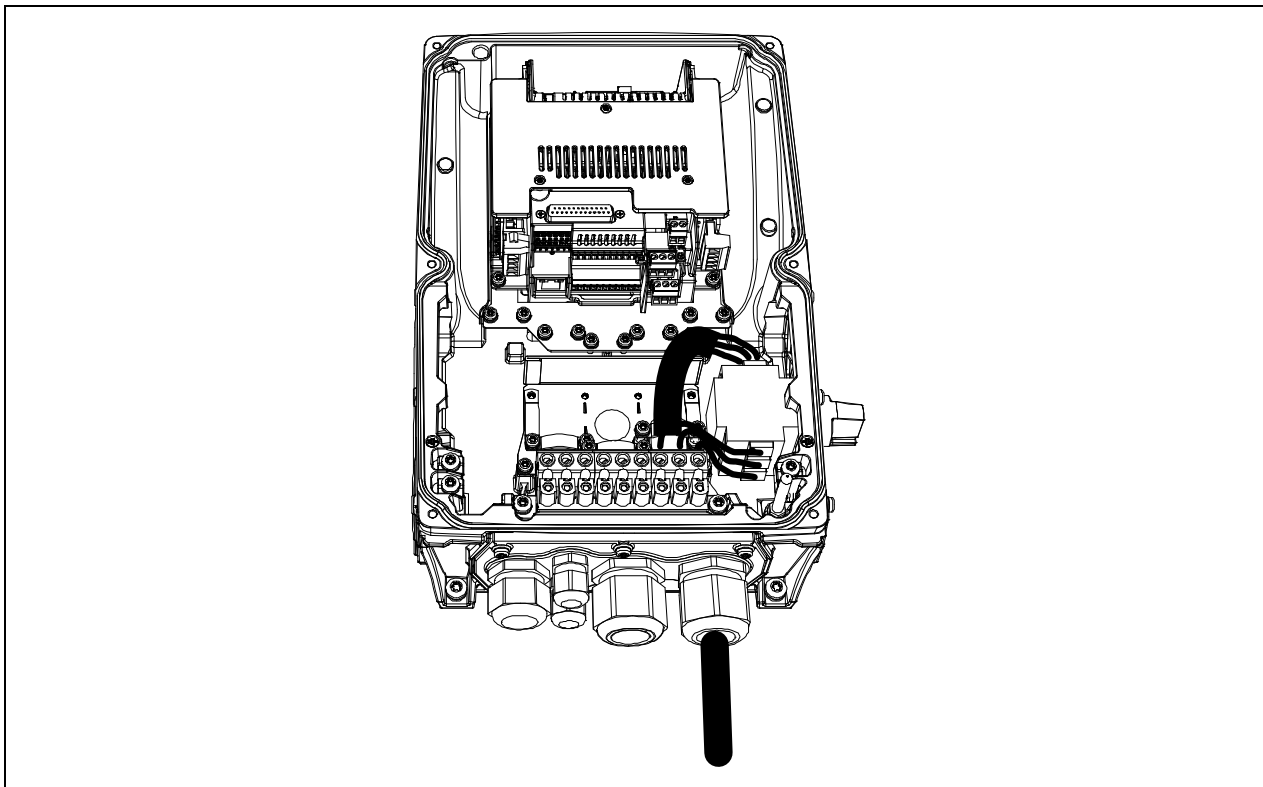

Figure 48. Mains switch, cable entry and cables connected

|          |  |
|----------|--|
| <b>8</b> | <ul style="list-style-type: none"> <li>Mount the powerhead on the terminal box with its screws: the installation process has been completed. See Figure 49.</li> </ul> |
|----------|--|

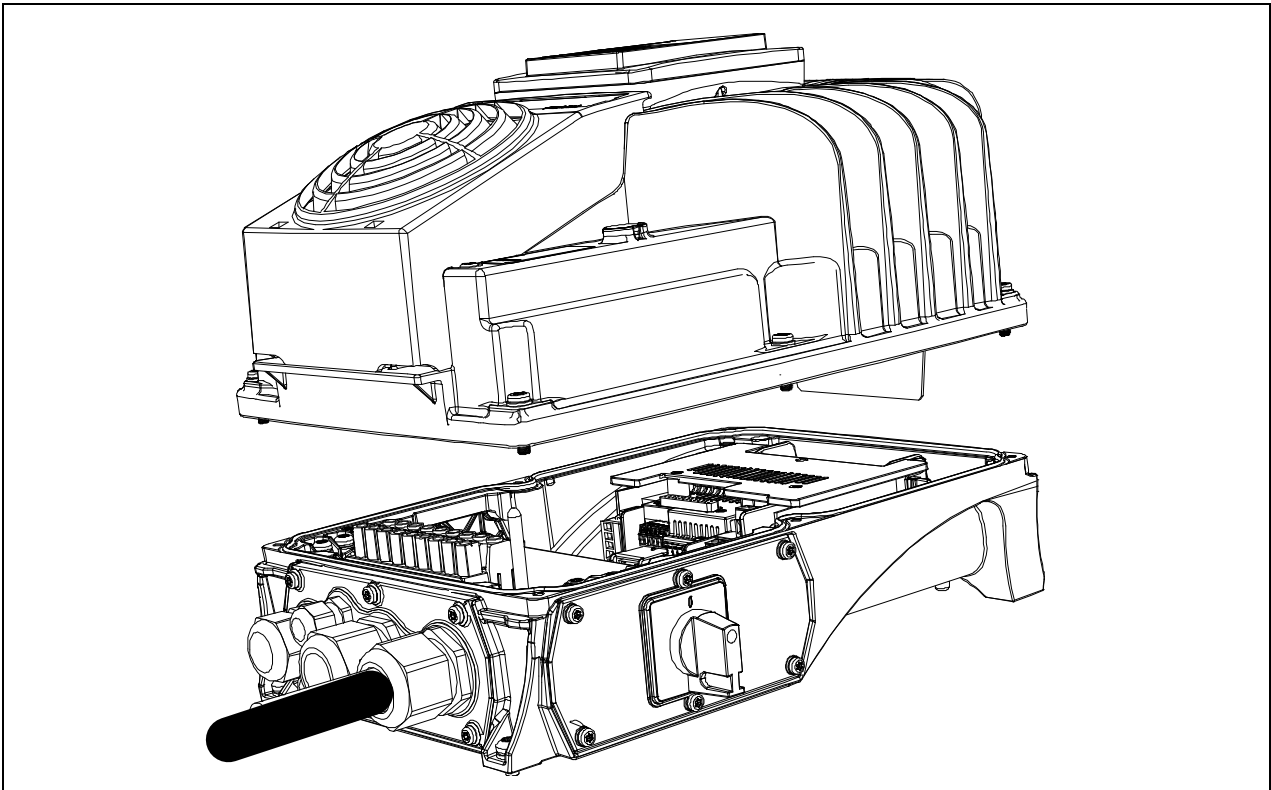

Figure 49. Mount the powerhead on the terminal box

## 8.2 CONTROL KEYPAD

The control keypad is the interface between the VACON® 100 X AC drive and the user. With the control keypad it is possible to control the speed of a motor, to supervise the state of the equipment and to set the AC drive's parameters.

The keypad is an option and can be delivered separately. The option includes the keypad, the keypad holder and three screws. You can use one screw to fix the keypad holder to the drive or three screws to fix the keypad holder to an enclosure/cabinet or any special housing for the drive in which you want to have a remote keypad control available.

Table 39. Keypad order codes

| Order code       | Description                               | Type of option |
|------------------|---|----------------|
| PAN-HMWM-MK02    | Keypad Wallmounting Kit                   | Loose Option   |
| CAB-HMI2M-MC05-X | MC05 HMI cable l=2m for -X keypads Option | Loose Option   |
| CAB-HMI5M-MC05-X | MC05 HMI cable l=5m for -X keypads Option | Loose Option   |

### 8.2.1 MOUNTING ONTO THE DRIVE

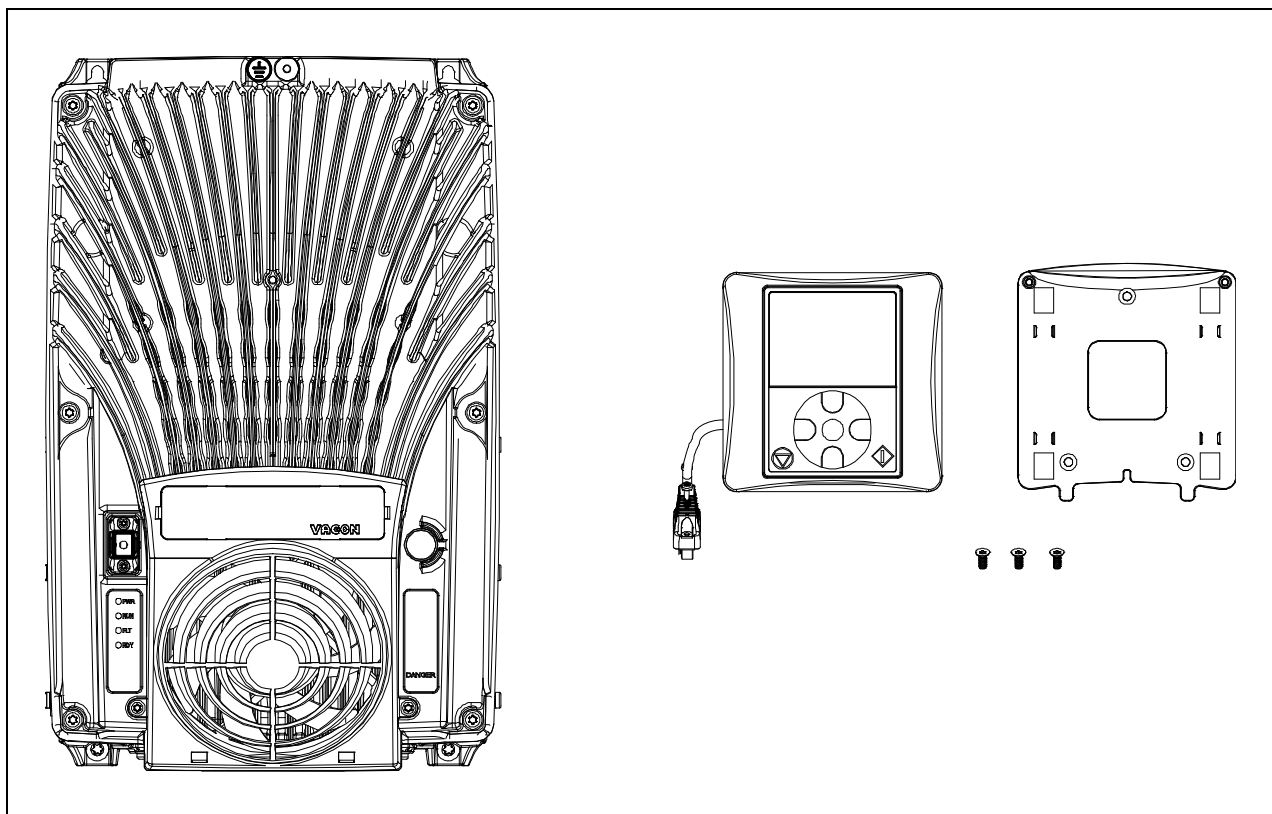

Figure 50. Drive and the optional keypad kit

**8.2.2 INSTALLATION****1**

- Remove the HMI cap from the drive as shown in the Figure 51.

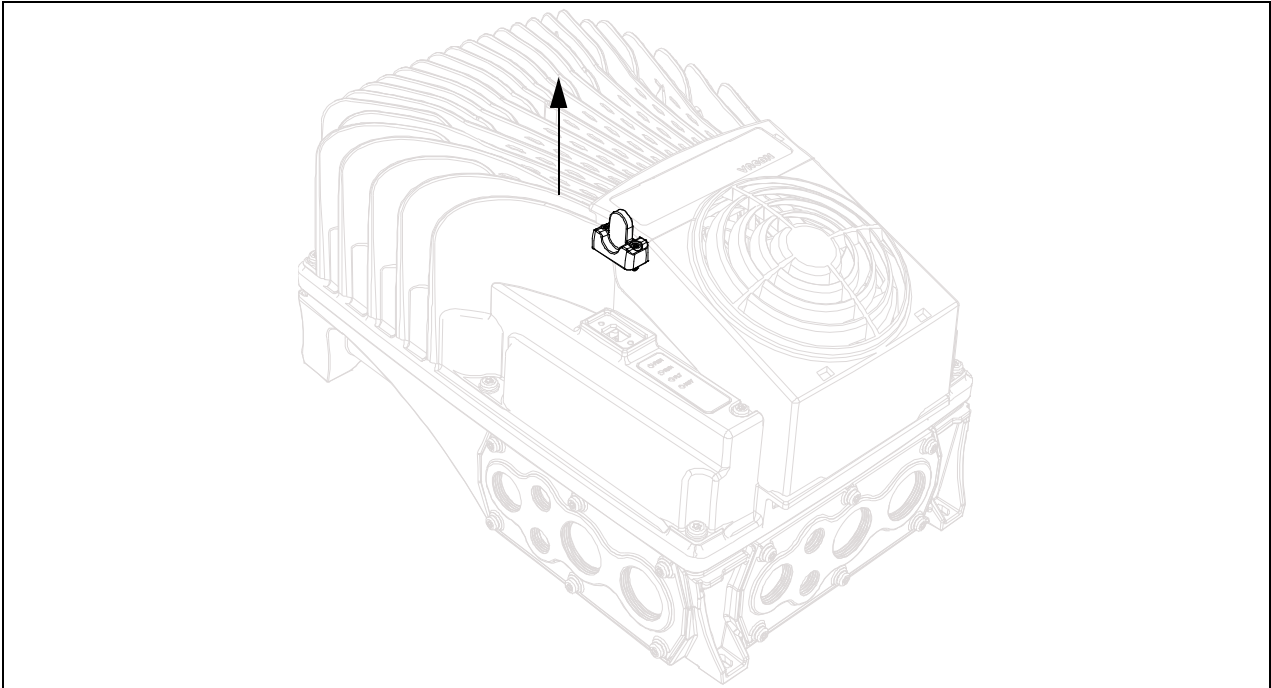

Figure 51. Disconnection of the HMI cap from the drive

**2**

- Install the keypad holder with a screw as shown in the Figure 52. The metal sheets of the keypad holder have to be mounted under the fan holder as shown in the following figures.

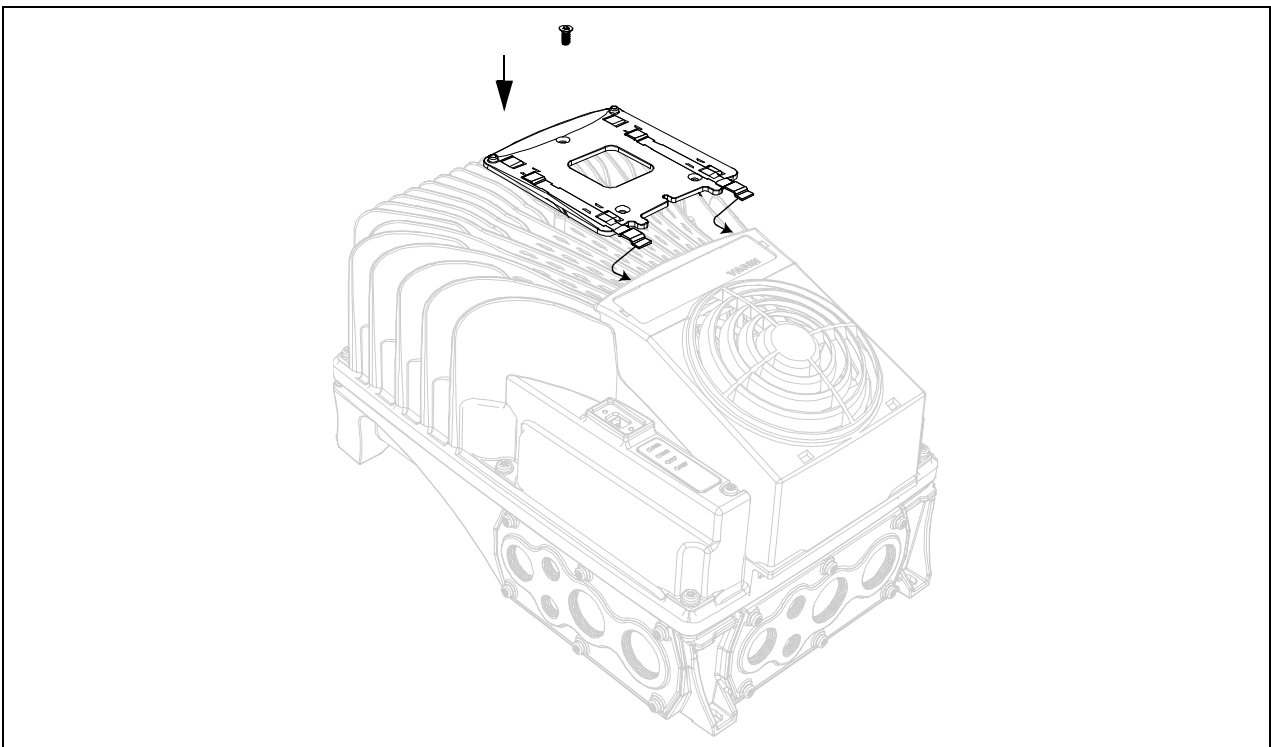

Figure 52. Installation of the keypad holder on the powerhead



**3**

- Connect the keypad to the drive and plug the cable on the HMI connector as shown in the Figure 53 and in the Figure 54.

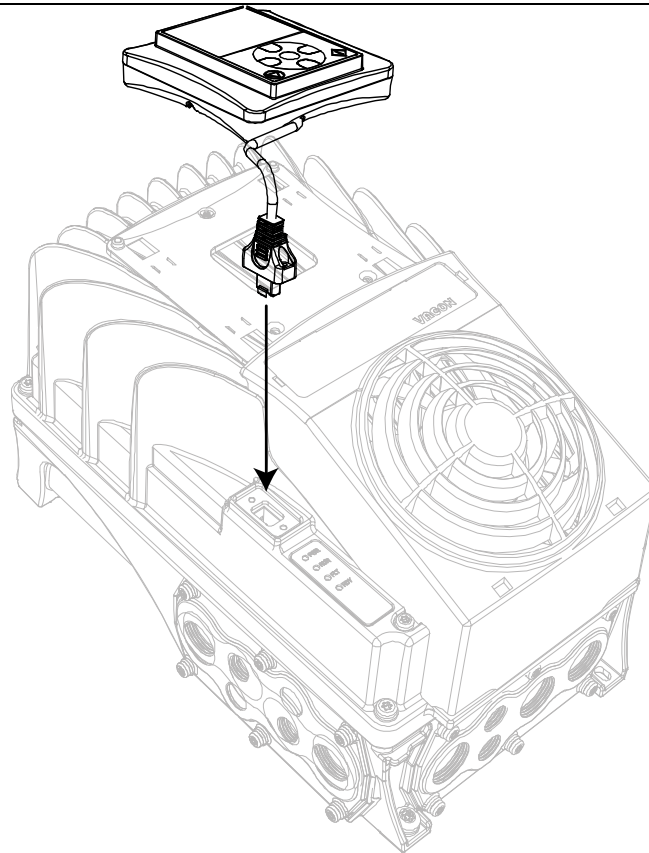

Figure 53. Mounting of the keypad

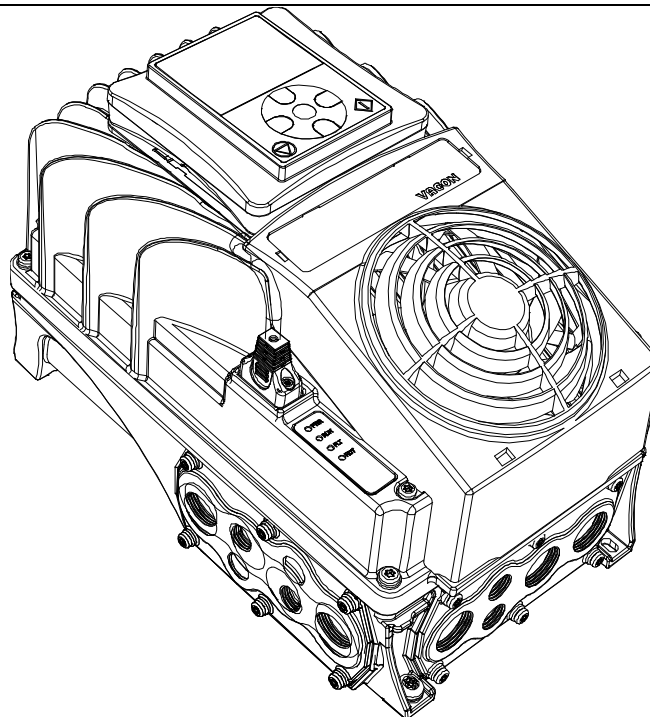

Figure 54. Keypad mounted onto the drive. Tighten the fixing screws of the cable connector (to 0.5 Nm or 4.5 lb-in) to the enclosure of the drive. This is to keep the high IP66 protection degree of the drive.

### 8.2.3 WALL-MOUNTING

The keypad can be mounted on the wall in a convenient location by using the same keypad holder and three screws provided with the keypad option kit.

**1**

- *Fix the keypad holder with three screws to the wall.*

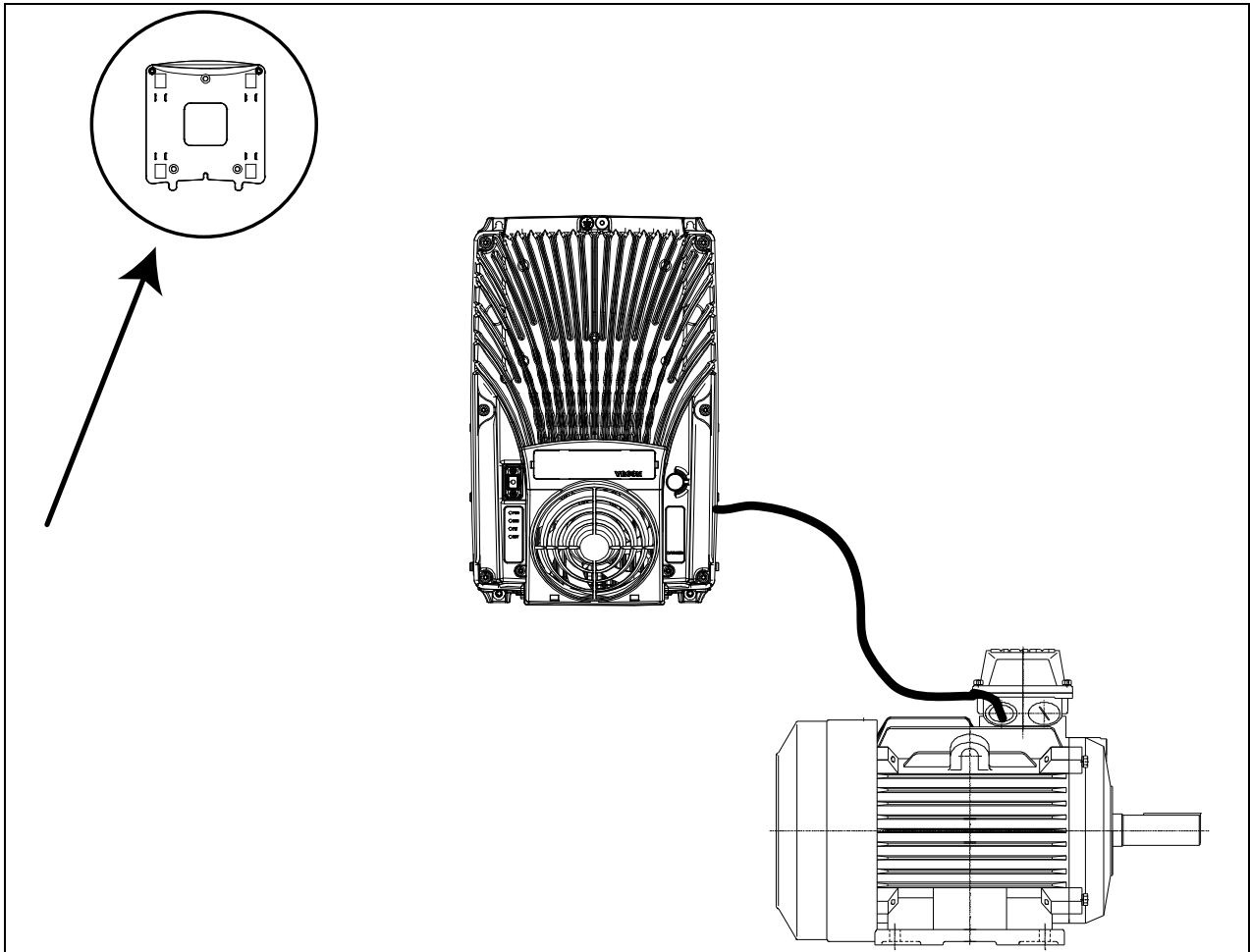

Figure 55. Fix the keypad holder with three screws to the wall

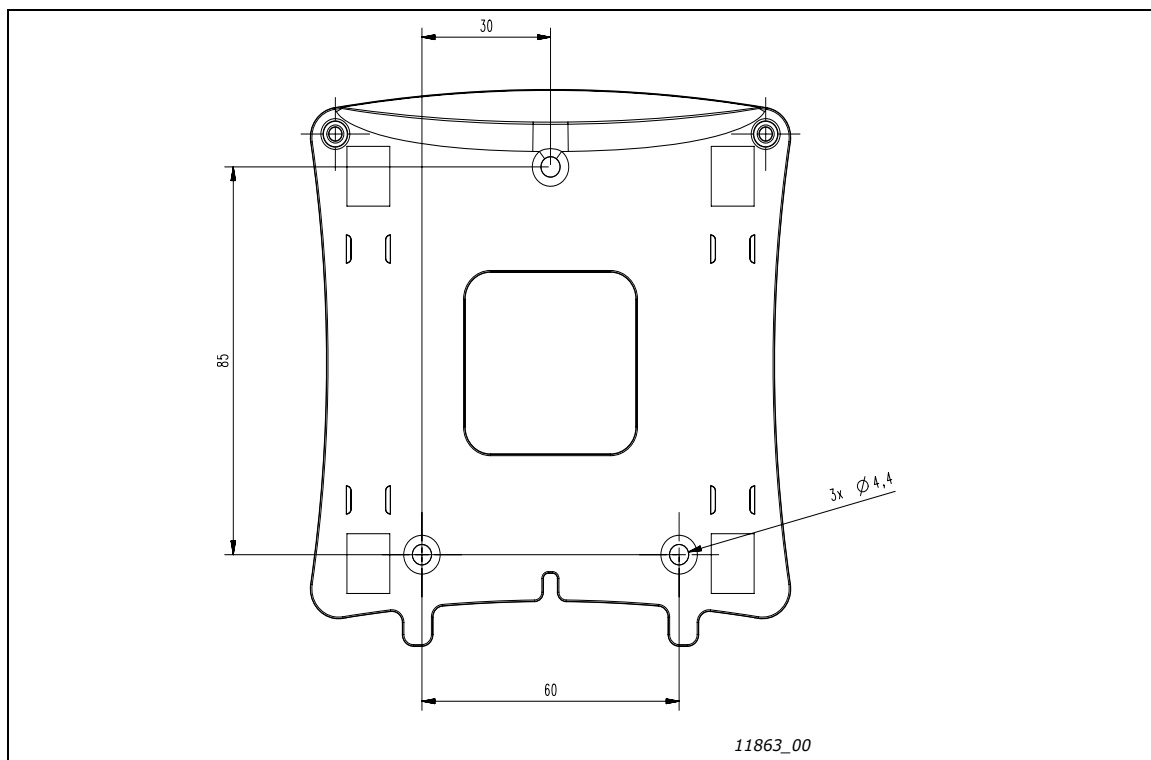

Figure 56. Display holder dimensions for wall-mounting

**2**

- Connect and fix the cable to the enclosure of the drive and hold the keypad to the wall.

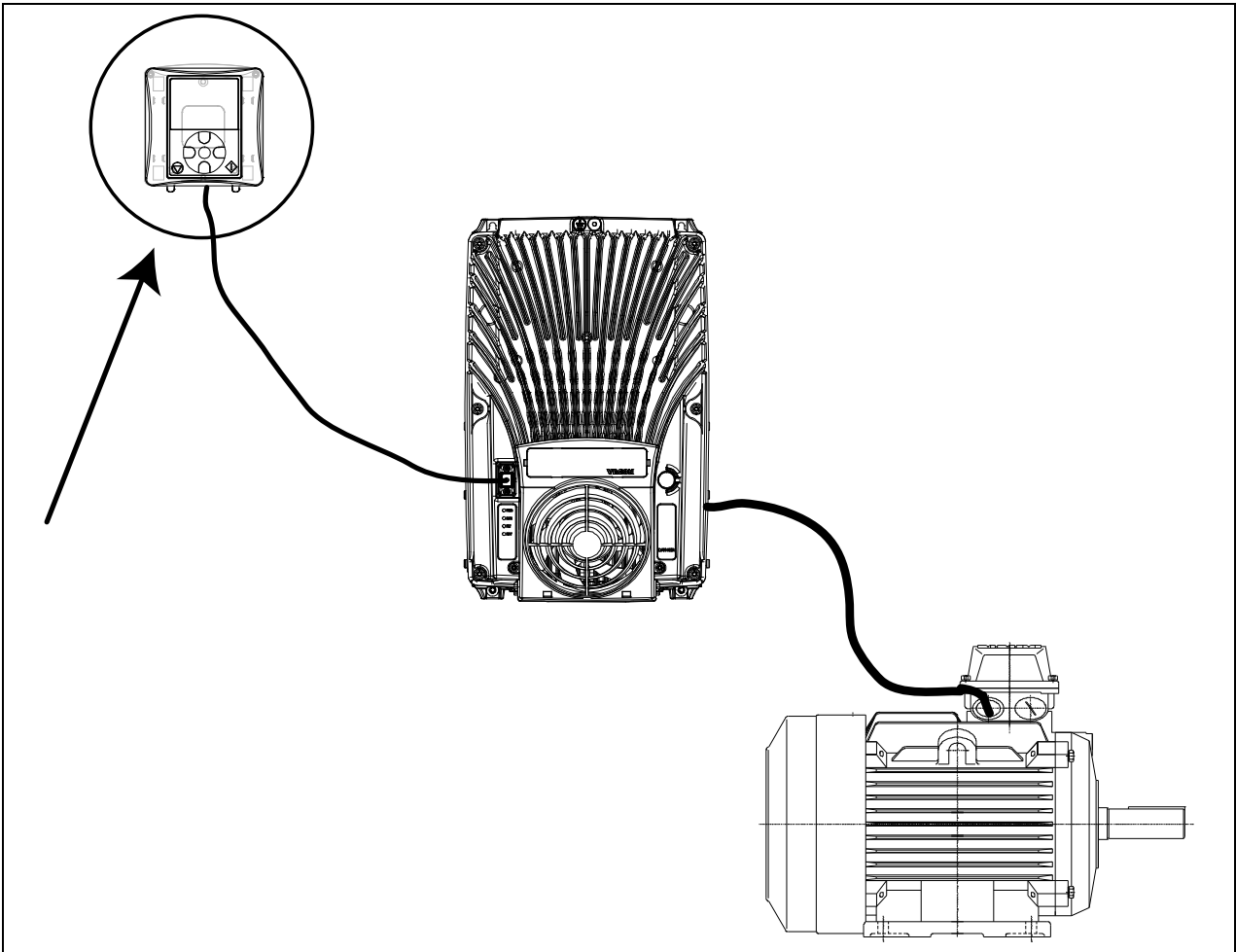

Figure 57. Keypad connected to the drive

**8.2.4 GRAPHICAL AND TEXT KEYPAD**

There are two keypad types you can choose for your user interface: keypad with graphical display and keypad with text segment display (text keypad).

The button section of the keypad is identical for both keypad types.

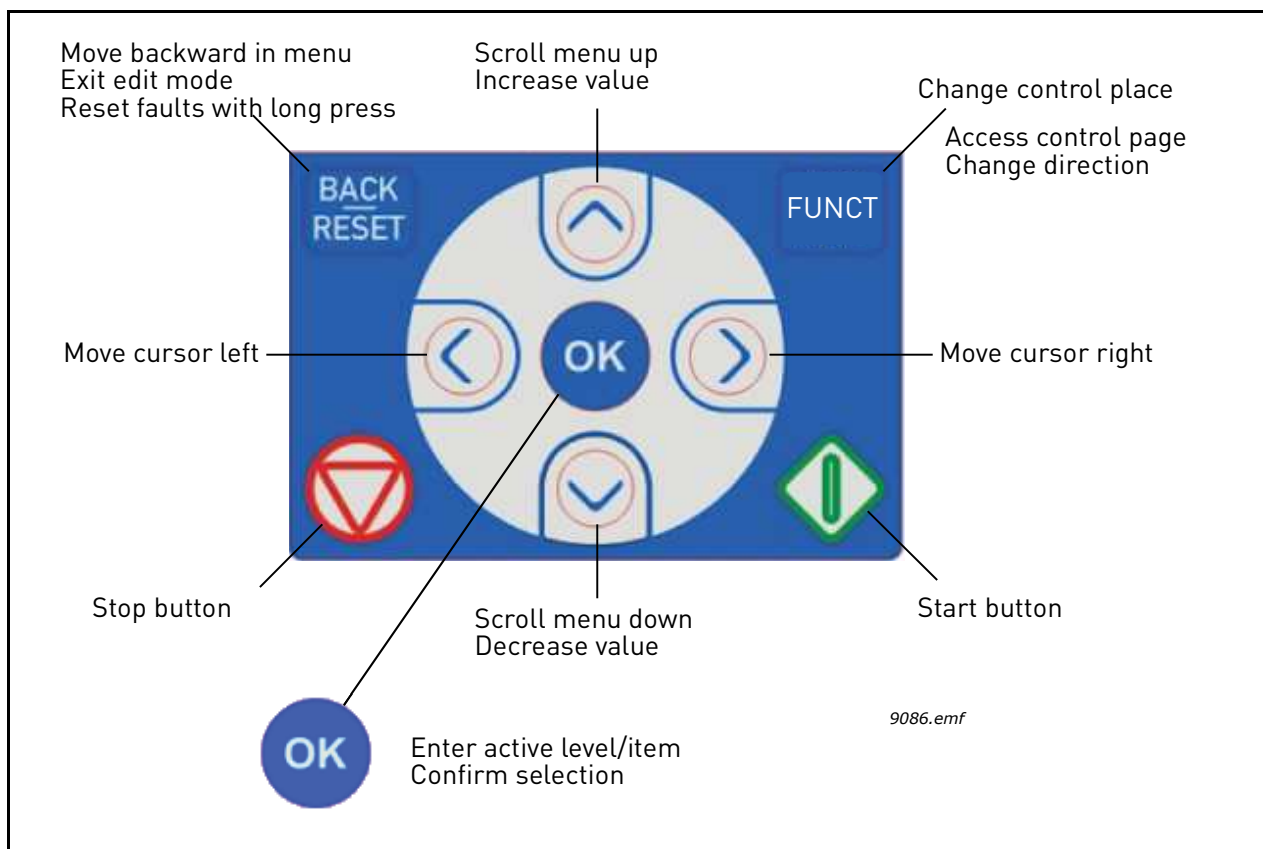

Figure 58. Keypad buttons

### 8.2.5 VACON® KEYPAD WITH GRAPHICAL DISPLAY

The graphical keypad features an LCD display and 9 buttons.

#### 8.2.5.1 Keypad display

The keypad display indicates the status of the motor and the drive and any irregularities in motor or drive functions. On the display, the user sees information about his present location in the menu structure and the item displayed.

#### 8.2.5.2 Main menu

The data on the control keypad are arranged in menus and submenus. Use the Up and Down arrows to move between the menus. Enter the group/item by pressing the OK button and return to the former level by pressing the Back/Reset button.

The *Location field* indicates your current location. The *Status field* gives information about the present status of the drive. See Figure 59.

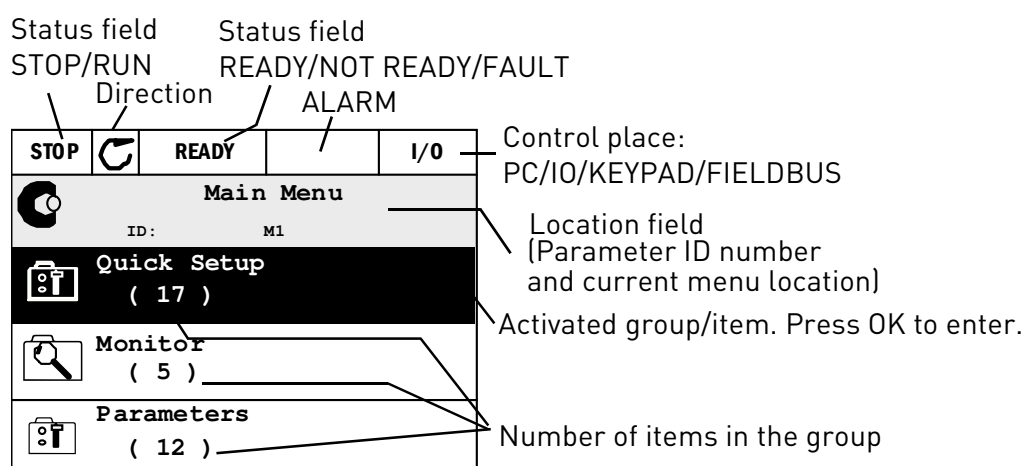

Figure 59. Main menu

#### 8.2.5.3 Using the graphical keypad

##### Editing values

The selectable values can be accessed and edited in two different ways on the graphical keypad.

##### Parameters with one valid value

Typically, one parameter is set one value. The value is selected either from a list of values (see example below) or the parameter is given a numerical value from a defined range (e.g. 0.00...50.00 Hz).

Change value of a parameter following the procedure below:

1. Locate the parameter.
2. Enter the *Edit* mode.
3. Set new value with the arrow buttons up/down. You can also move from digit to digit with the arrow buttons left/right if the value is numerical and then change the value with the arrow buttons up/down.
4. Confirm change with OK button or ignore change by returning to previous level with Back/Reset button.

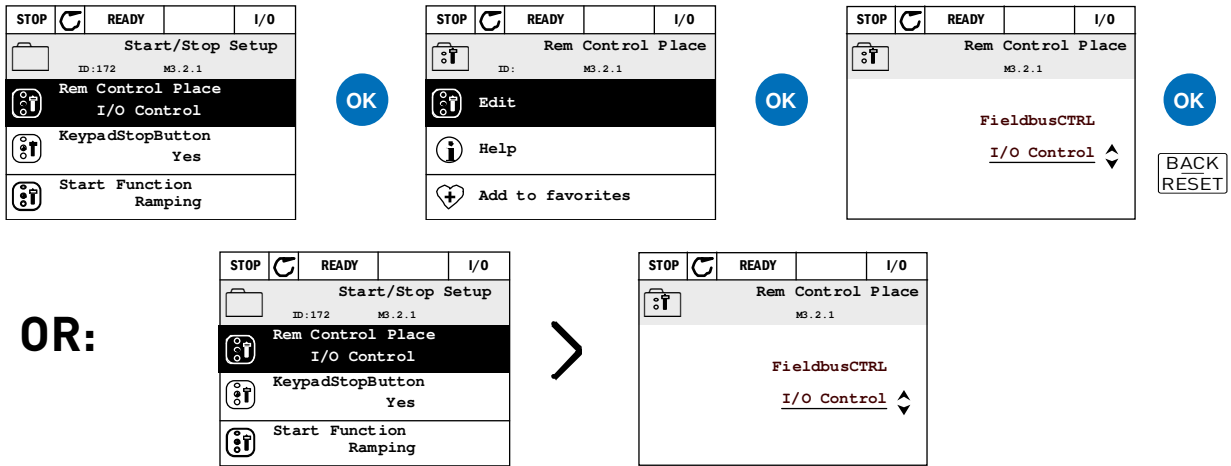

Figure 60. Typical editing of values on graphical keypad (text value)



Figure 61. Typical editing of values on graphical keypad (numerical value)

**Parameters with checkbox selection**

Some parameters allow selecting several values. Make a checkbox selection at each value you wish to activate as instructed below.

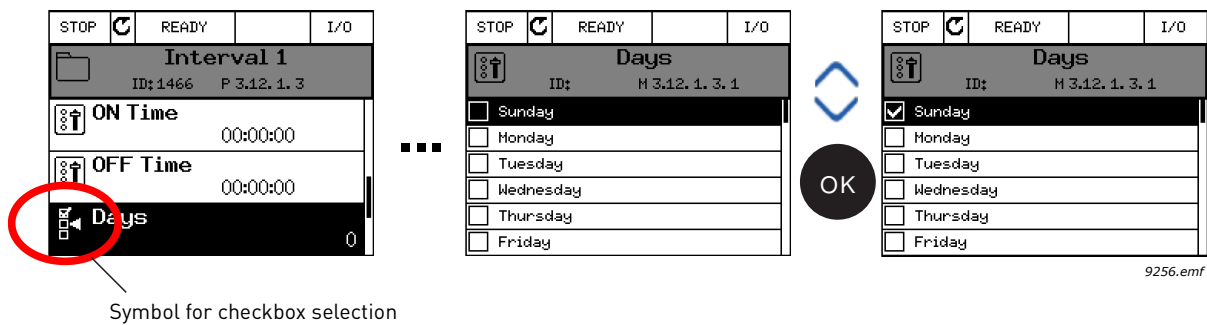

Symbol for checkbox selection

Figure 62. Applying the checkbox value selection on graphical keypad

## Resetting fault

Instructions for how to reset a fault can be found in chapter 8.2.7.

## Function button

The FUNCT button is used for four functions:

1. to quickly access the Control page,
2. to easily change between the Local (Keypad) and Remote control places,
3. to change the rotation direction and
4. to quickly edit a parameter value.

## Control places

The *control place* is the source of control where the drive can be started and stopped. Every control place has its own parameter for selecting the frequency reference source. The *Local control place* is always the keypad. The *Remote control place* is determined by parameter P3.2.1 (I/O or Fieldbus). The selected control place can be seen on the status bar of the keypad.

## Remote control place

I/O A, I/O B and Fieldbus can be used as remote control places. I/O A and Fieldbus have the lowest priority and can be chosen with parameter P3.2.1 (*Rem Control Place*). I/O B, again, can bypass the remote control place selected with parameter P3.2.1 using a digital input. The digital input is selected with parameter P3.5.1.7 (*I/O B Ctrl Force*).

## Local control

Keypad is always used as control place while in local control. Local control has higher priority than remote control. Therefore, if, for example, bypassed by parameter P3.5.1.7 through digital input while in *Remote*, the control place will still switch to Keypad if *Local* is selected. Switching between Local and Remote Control can be done by pressing the FUNCT-button on the keypad or by using the "Local/Remote" (ID211) parameter.

## Changing control places

Change of control place from *Remote* to *Local* (keypad).

1. Anywhere in the menu structure, push the *FUNCT* button.
2. Push the *Arrow up* or the *Arrow down* button to select *Local/Remote* and confirm with the *OK* button.
3. On the next display, select *Local* or *Remote* and again confirm with the *OK* button.
4. The display will return to the same location as it was when the *FUNCT* button was pushed. However, if the Remote control place was changed to Local (Keypad) you will be prompted for keypad reference.



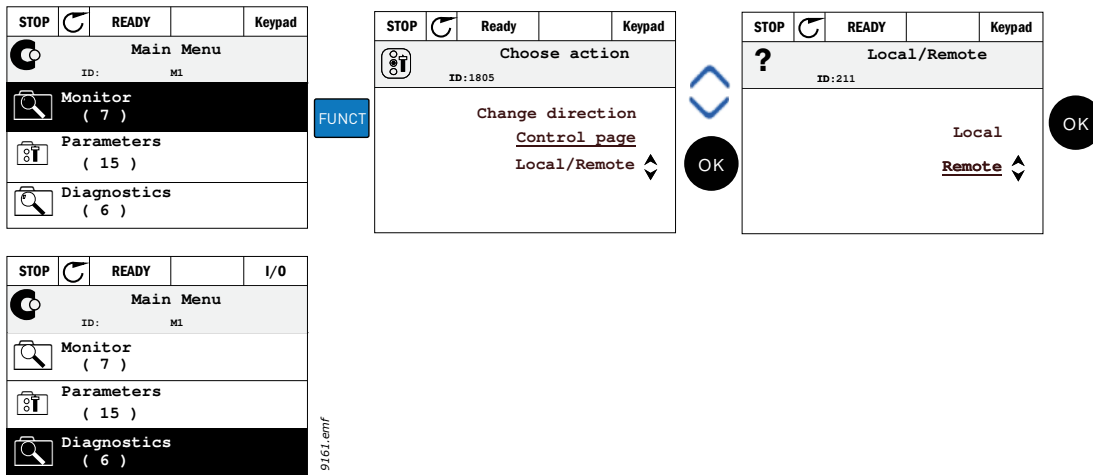

Figure 63. Changing control places

### Accessing the control page

The *Control page* is meant for easy operation and monitoring of the most essential values.

1. Anywhere in the menu structure, push the *FUNCT* button.
2. Push the *Arrow up* or the *Arrow down* button to select *Control page* and confirm with the *OK* button.
3. The control page appears

If keypad control place and keypad reference are selected to be used you can set the *Keypad Reference* after having pressed the *OK* button. If other control places or reference values are used the display will show Frequency reference which is not editable. The other values on the page are Multimonitoring values. You can choose which values appear here for monitoring.

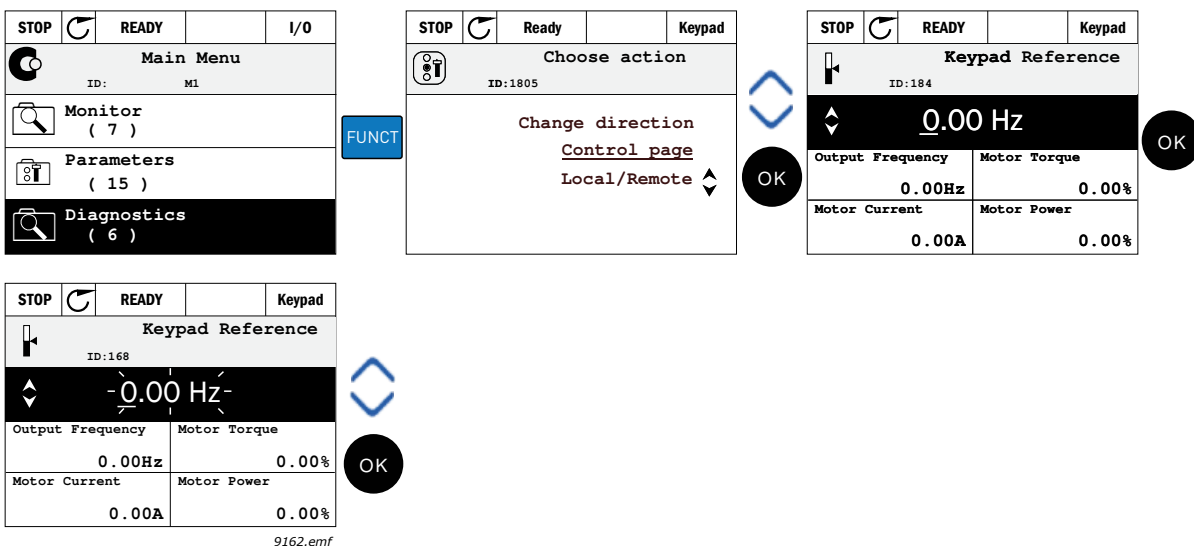

Figure 64. Accessing Control page

### Changing direction

Rotation direction of the motor can quickly be changed by applying the FUNCT button. **NOTE!** *Changing direction* command is not visible in the menu unless the selected control place is *Local*.

1. Anywhere in the menu structure, push the Funct button.
2. Push the Arrow up or the Arrow down button to select Change direction and confirm with the OK button.
3. Then choose the direction you wish to run the motor to. The actual rotation direction is blinking. Confirm with the OK button.
4. The rotation direction changes immediately and the arrow indication in the status field changes.

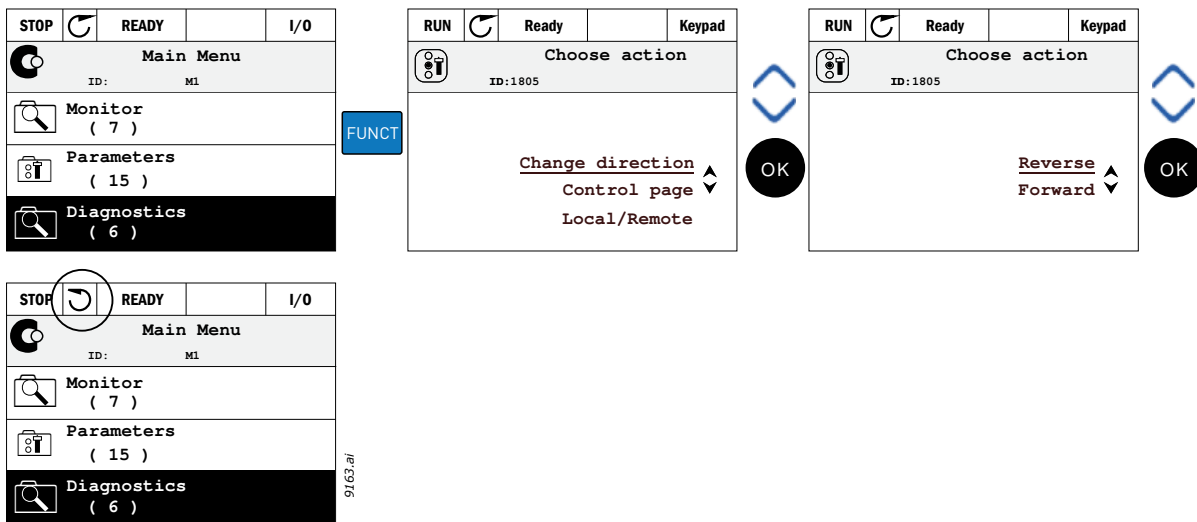

Figure 65. Changing direction

### Quick edit

Through the *Quick edit* functionality you can quickly access the desired parameter by entering the parameter’s ID number.

1. Anywhere in the menu structure, push the FUNCT button.
2. Push the Arrow up or the Arrow down buttons to select Quick Edit and confirm with the OK button.
3. Then enter the ID number of parameter or monitoring value you wish to access. Press OK button to confirm.
4. Requested Parameter/Monitoring value appears on the display (in editing/monitoring mode.)

### Copying parameters

**NOTE:** This feature is available with graphical keypad only.

The parameter copy function can be used to copy parameters from one drive to another.

The parameters are first saved to the keypad, then the keypad is detached and connected to another drive. Finally the parameters are downloaded to the new drive restoring them from the keypad.

Before any parameters can successfully be copied from one drive to another the drive has to be stopped when the parameters are downloaded.

- First go into *User settings* menu and locate the *Parameter backup* submenu. In the *Parameter backup* submenu, there are three possible functions to be selected:
- *Restore factory defaults* will re-establish the parameter settings originally made at the factory.
- By selecting *Save to keypad* you can copy all parameters to the keypad.
- *Restore from keypad* will copy all parameters from keypad to a drive.

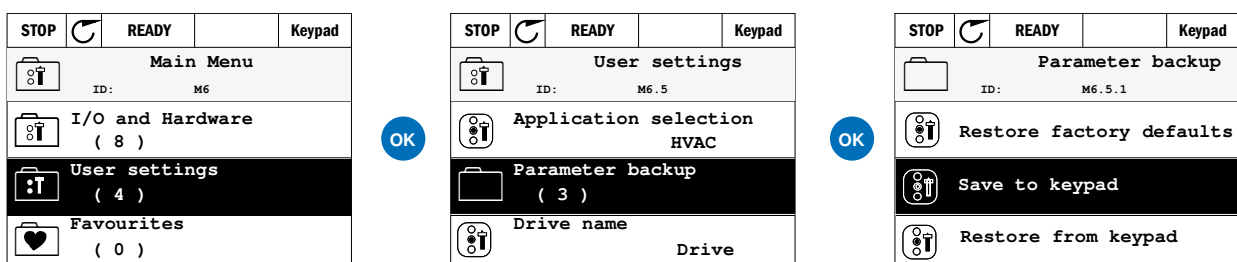

Figure 66. Parameter copy

**NOTE:** If the keypad is changed between drives of different sizes, the copied values of these parameters will not be used:

- Motor nominal current (P3.1.1.4)
- Motor nominal voltage (P3.1.1.1)
- Motor nominal speed (P3.1.1.3)
- Motor nominal power (P3.1.1.6)
- Motor nominal frequency (P3.1.1.2)
- Motor cos phi (P3.1.1.5)
- Switching frequency (P3.1.2.3)
- Motor current limit (P3.1.3.1)
- Stall current limit (P3.9.3.2)
- Stall time limit (P3.9.3.3)
- Stall frequency (P3.9.3.4)
- Maximum frequency (P3.3.1.2)

### Help texts

The graphical keypad features instant help and information displays for various items. All parameters offer an instant help display. Select Help and press the OK button. Text information is also available for faults, alarms and the startup wizard.

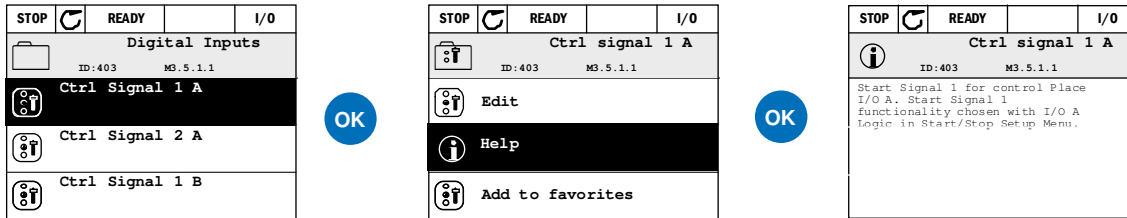

Figure 67. Help text example

### Adding item to favourites

You might need to refer to certain parameter values or other items often. Instead of locating them one by one in the menu structure, you may want to add them to a folder called *Favorites* where they can easily be reached.

To add an item to the Favorites.

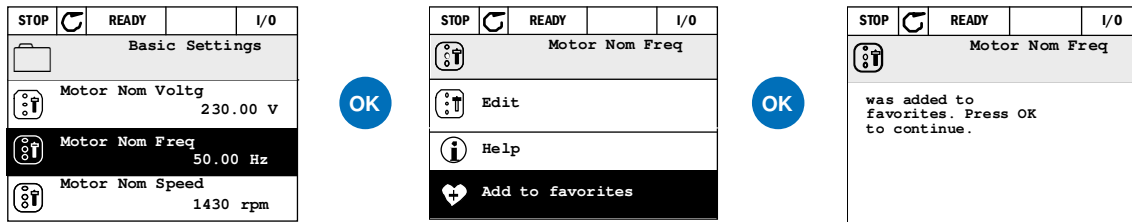

Figure 68. Adding item to Favorites

### 8.2.6 VACON® KEYPAD WITH TEXT SEGMENT DISPLAY

You can also choose a *Keypad with text segment display* (Text keypad) for your user interface. It has mainly the same functionalities as the keypad with graphical display although some of these are somewhat limited.

#### 8.2.6.1 Keypad display

The keypad display indicates the status of the motor and the drive and any irregularities in motor or drive functions. On the display, the user sees information about his present location in the menu structure and the item displayed. If the text on the text line is too long to fit in the display, the text will scroll from left to right to reveal the whole text string.

#### 8.2.6.2 Main menu

The data on the control keypad are arranged in menus and submenus. Use the Up and Down arrows to move between the menus. Enter the group/item by pressing the OK button and return to the former level by pressing the Back/Reset button.

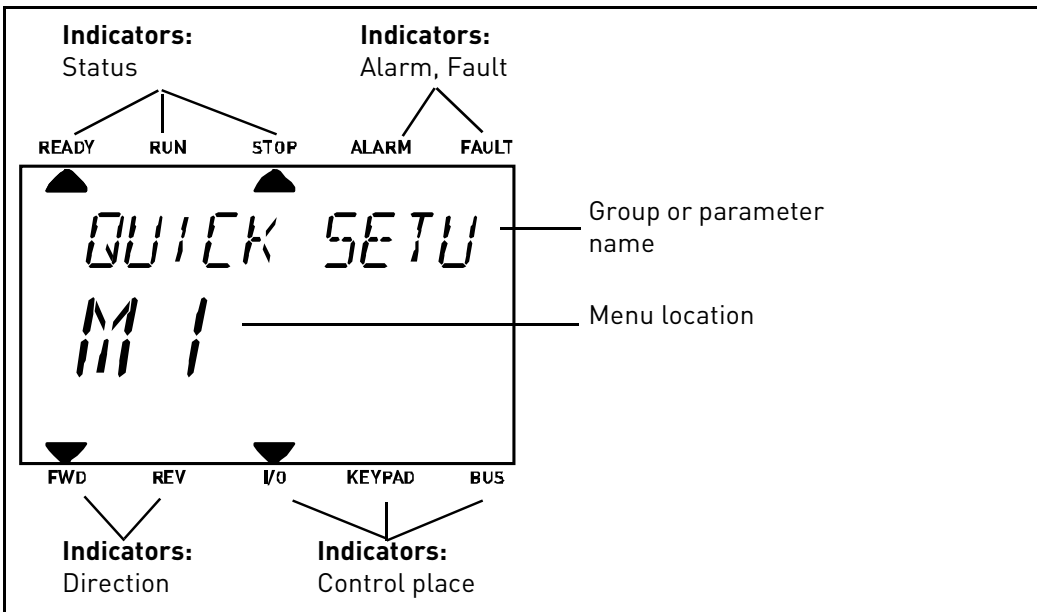

8.2.6.3 *Using the keypad*

**Editing values**

Change value of a parameter following the procedure below:

1. Locate the parameter.
2. Enter the Edit mode by pressing OK.
3. Set new value with the arrow buttons up/down. You can also move from digit to digit with the arrow buttons left/right if the value is numerical and change then the value with the arrow buttons up/down.
4. Confirm change with OK button or ignore change by returning to previous level with Back/Reset button.

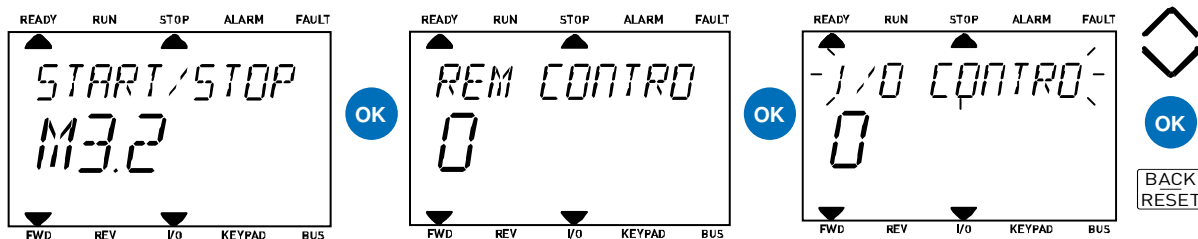

Figure 69. Editing values

**Resetting fault**

Instructions for how to reset a fault can be found in chapter 8.2.7.

**Function button**

The FUNCT button is used for four functions:

1. to quickly access the Control page,
2. to easily change between the Local (Keypad) and Remote control places,
3. to change the rotation direction and
4. to quickly edit a parameter value.

**Control places**

The *control place* is the source of control where the drive can be started and stopped. Every control place has its own parameter for selecting the frequency reference source. The *Local control place* is always the keypad. The *Remote control place* is determined by parameter P3.2.1 (I/O or Fieldbus). The selected control place can be seen on the status bar of the keypad.

**Remote control place**

I/O A, I/O B and Fieldbus can be used as remote control places. I/O A and Fieldbus have the lowest priority and can be chosen with parameter P3.2.1 (*Rem Control Place*). I/O B, again, can bypass the remote control place selected with parameter P3.2.1 using a digital input. The digital input is selected with parameter P3.5.1.7 (*I/O B Ctrl Force*).

**Local control**

Keypad is always used as control place while in local control. Local control has higher priority than remote control. Therefore, if, for example, bypassed by parameter P3.5.1.7 through digital input while in *Remote*, the control place will still switch to Keypad if *Local* is selected. Switching between Local and Remote Control can be done by pressing the FUNCT-button on the keypad or by using the "Local/Remote" (ID211) parameter.

### Changing control places

Change of control place from *Remote* to *Local* (keypad).

1. Anywhere in the menu structure, push the *FUNCT* button.
2. Using the arrow buttons, select *Local/Remote* and confirm with the *OK* button.
3. On the next display, select *Local* or *Remote* and again confirm with the *OK* button.
4. The display will return to the same location as it was when the *FUNCT* button was pushed. However, if the *Remote* control place was changed to *Local* (Keypad) you will be prompted for keypad reference.

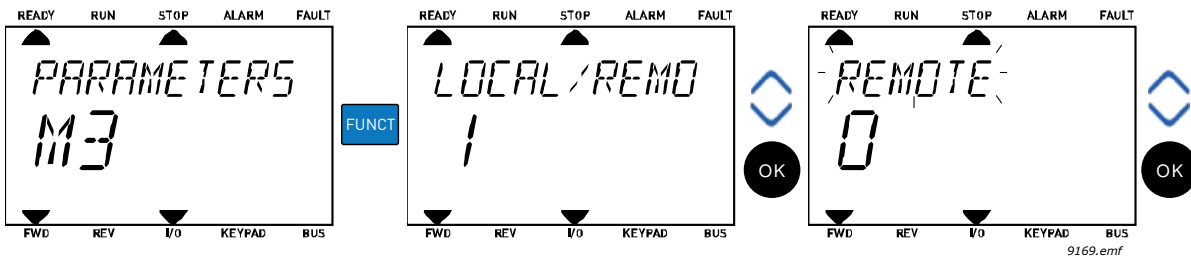

Figure 70. Changing control places

### Accessing the control page

The *Control page* is meant for easy operation and monitoring of the most essential values.

1. Anywhere in the menu structure, push the *FUNCT* button.
2. Push the *Arrow up* or the *Arrow down* button to select *Control page* and confirm with the *OK* button.
3. The control page appears  
 If keypad control place and keypad reference are selected to be used you can set the *Keypad Reference* after having pressed the *OK* button. If other control places or reference values are used the display will show Frequency reference which is not editable.

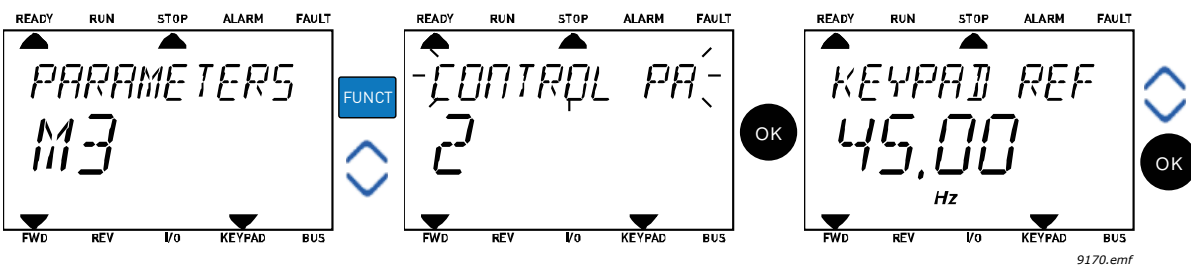

Figure 71. Accessing Control page

### Changing direction

Rotation direction of the motor can quickly be changed by applying the FUNCT button. **NOTE!** *Changing direction* command is not visible in the menu unless the selected control place is *Local*.

1. Anywhere in the menu structure, push the Funct button.
2. Push the Arrow up or the Arrow down button to select Change direction and confirm with the OK button.
3. Then choose the direction you wish to run the motor to. The actual rotation direction is blinking. Confirm with the OK button.
4. The rotation direction changes immediately and the arrow indication in the status field changes.

### Quick edit

Through the *Quick edit* functionality you can quickly access the desired parameter by entering the parameter's ID number.

1. Anywhere in the menu structure, push the FUNCT button.
2. Push the Arrow up or the Arrow down buttons to select Quick Edit and confirm with the OK button.
3. Then enter the ID number of parameter or monitoring value you wish to access. Press OK button to confirm.
4. Requested Parameter/Monitoring value appears on the display (in editing/monitoring mode.)



### 8.2.7 FAULT TRACING

When an unusual operating condition is detected by the AC drive control diagnostics, the drive initiates a notification visible, for example, on the keypad. The keypad will show the code, the name and a short description of the fault or alarm.

The notifications vary in consequence and required action. *Faults* make the drive stop and require reset of the drive. *Alarms* inform of unusual operating conditions but the drive will continue running. *Info* may require resetting but do not affect the functioning of the drive.

For some faults you can program different responses in the application. See parameter group Protections.

The fault can be reset with the *Reset button* on the control keypad or via the I/O terminal. The faults are stored in the Fault history menu which can be browsed. The different fault codes you will find in the table below.

**NOTE:** When contacting distributor or factory because of a fault condition, always write down all texts and codes on the keypad display.

#### Fault appears

When a fault appears and the drive stops, examine the cause of fault, perform the actions advised here and reset the fault as instructed below.

1. With a long (1 s) press on the *Reset* button on the keypad or
2. By entering the *Diagnostics* Menu (M4), entering *Reset faults* (M4.2) and selecting *Reset faults* parameter.
3. **For keypad with LCD display only:** By selecting value Yes for the parameter and clicking OK.

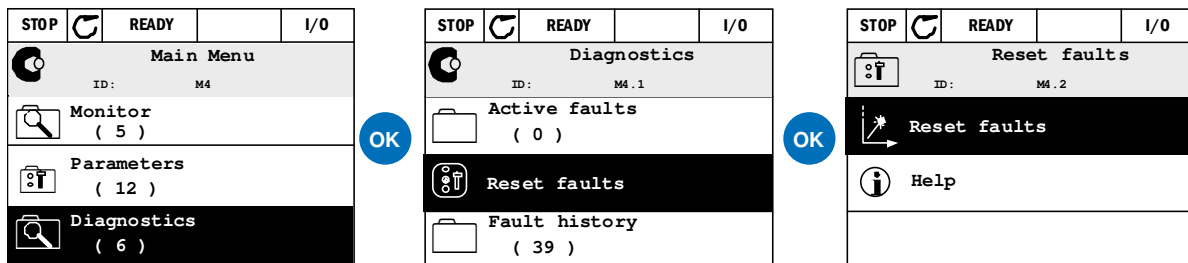

Figure 72. Diagnostic menu with graphical keypad

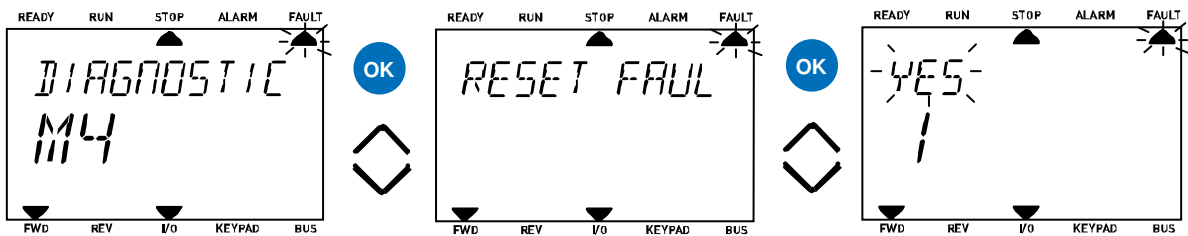

Figure 73. Diagnostic menu with text keypad

8.2.7.1 *Fault History*

In menu M4.3 Fault history you find the maximum number of 40 occurred faults. On each fault in the memory you will also find additional information, see below.

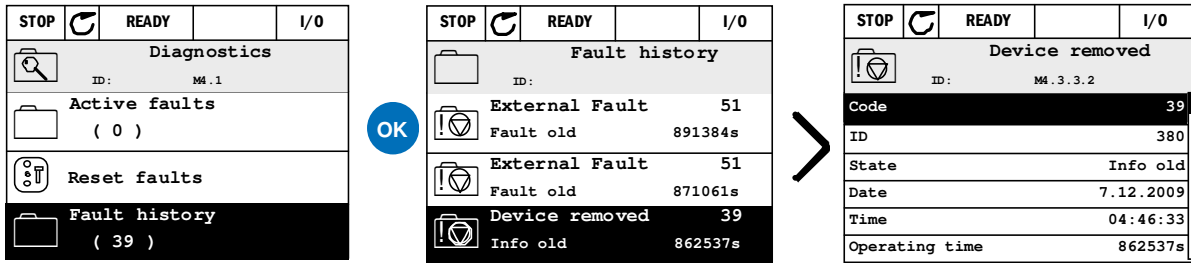

Figure 74. Fault history menu with graphical keypad

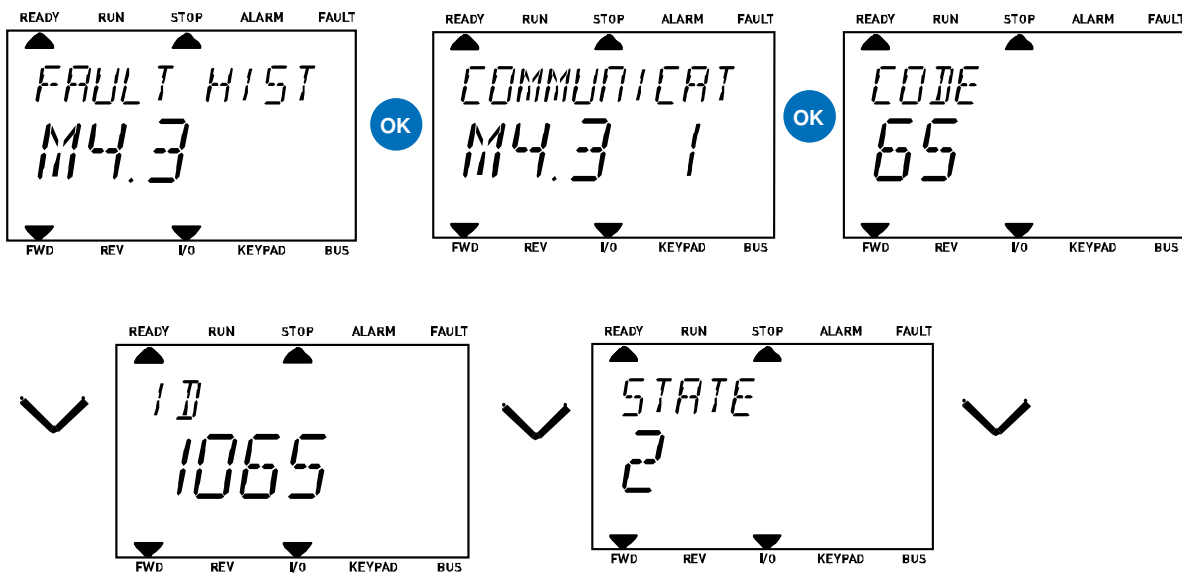

Figure 75. Fault history menu with text keypad

8.2.7.2 *Fault codes*

Table 40. *Fault codes and descriptions.*

| Fault code | Fault ID | Fault name                   | Possible cause  | Remedy  |
|------------|----------|------------------------------|---|---|
| 1          | 1        | Overcurrent (hardware fault) | AC drive has detected too high a current ( $>4 \cdot I_M$ ) in the motor cable:   | Check loading.<br>Check motor.<br>Check cables and connections.<br>Make identification run.<br>Check ramp times.  |
|            | 2        | Overcurrent (software fault) | <ul style="list-style-type: none"> <li>sudden heavy load increase</li> <li>short circuit in motor cables</li> <li>unsuitable motor</li> </ul>   |   |
| 2          | 10       | Overvoltage (hardware fault) | The DC-link voltage has exceeded the limits defined.  | Make deceleration time longer.<br>Use brake chopper or brake resistor (available as options).<br>Activate overvoltage controller.<br>Check input voltage.                               |
|            | 11       | Overvoltage (software fault) | <ul style="list-style-type: none"> <li>too short a deceleration time</li> <li>brake chopper is disabled</li> <li>high overvoltage spikes in supply</li> <li>Start/Stop sequence too fast</li> </ul> |   |
| 3          | 20       | Earth fault (hardware fault) | Current measurement has detected that the sum of motor phase current is not zero. <ul style="list-style-type: none"> <li>insulation failure in cables or motor</li> </ul>                           | Check motor cables and motor.   |
|            | 21       | Earth fault (software fault) |   |   |
| 5          | 40       | Charging switch              | The charging switch is open, when the START command has been given. <ul style="list-style-type: none"> <li>faulty operation</li> <li>component failure</li> </ul>                                   | Reset the fault and restart.<br>Should the fault re-occur, contact the distributor near to you.   |
| 7          | 60       | Saturation                   | Various causes: <ul style="list-style-type: none"> <li>defective component</li> <li>brake resistor short-circuit or overload</li> </ul>   | Cannot be reset from keypad.<br>Switch off power.<br><b>DO NOT RE-CONNECT POWER!</b><br>Contact factory.<br>If this fault appears simultaneously with F1, check motor cables and motor. |

Table 40. Fault codes and descriptions.

| Fault code | Fault ID  | Fault name           | Possible cause  | Remedy   |
|------------|---|----------------------|---|--|
| 8          | 600   | System fault         | Communication between control board and power unit has failed.  | Reset the fault and restart. Should the fault re-occur, contact the distributor near to you.   |
|            | 601   |                      | Communication between control board and power unit has interference, but it is still working.   |  |
|            | 602   |                      | Watchdog has reset the CPU  |  |
|            | 603   |                      | Voltage of auxiliary power in power unit is too low.  |  |
|            | 604   |                      | Phase fault: Voltage of an output phase does not follow the reference   |  |
|            | 605   |                      | CPLD has faulted but there is no detailed information about the fault   |  |
|            | 606   |                      | Control and power unit software are incompatible  | Update software. Should the fault re-occur, contact the distributor near to you.   |
|            | 607   |                      | Software version cannot be read. There is no software in power unit.  | Update power unit software. Should the fault re-occur, contact the distributor near to you.  |
|            | 608   |                      | CPU overload. Some part of the software (for example application) has caused an overload situation. The source of fault has been suspended  | Reset the fault and restart. Should the fault re-occur, contact the distributor near to you.   |
|            | 609   |                      | Memory access has failed. For example, retain variables could not be restored.  |  |
|            | 610   |                      | Necessary device properties cannot be read.   |  |
|            | 614   |                      | Configuration error.  |  |
|            | 647   |                      | Software error  | Update software. Should the fault re-occur, contact the distributor near to you.   |
|            | 648   |                      | Invalid function block used in application. System software and application are not compatible.   |  |
| 649        | Resource overload.<br>Error when loading parameter initial values.<br>Error when restoring parameters.<br>Error when saving parameters. |                      |   |  |
| 9          | 80  | Undervoltage (fault) | DC-link voltage is under the voltage limits defined. <ul style="list-style-type: none"> <li>• most probable cause: too low a supply voltage</li> <li>• AC drive internal fault</li> <li>• defect input fuse</li> <li>• external charge switch not closed</li> </ul> <b>NOTE!</b> This fault is activated only if the drive is in Run state. | In case of temporary supply voltage break reset the fault and restart the AC drive. Check the supply voltage. If it is adequate, an internal failure has occurred.<br>Contact the distributor near to you. |
|            | 81  | Undervoltage (alarm) |   |  |
| 10         | 91  | Input phase          | Input line phase is missing.  | Check supply voltage, fuses and cable.   |

Table 40. Fault codes and descriptions.

| Fault code | Fault ID | Fault name                                 | Possible cause  | Remedy   |
|------------|----------|--|---|--|
| 11         | 100      | Output phase supervision                   | Current measurement has detected that there is no current in one motor phase.   | Check motor cable and motor.   |
| 12         | 110      | Brake chopper supervision (hardware fault) | No brake resistor installed.<br>Brake resistor is broken.   | Check brake resistor and cabling.<br>If these are ok, the chopper is faulty. Contact the distributor near to you.  |
|            | 111      | Brake chopper saturation alarm             | Brake chopper failure.  |  |
| 13         | 120      | AC drive undertemperature (fault)          | Too low temperature measured in power unit's heatsink or board. Heatsink temperature is under -10°C.  | Check the ambient temperature  |
| 14         | 130      | AC drive overtemperature (fault, heatsink) | Too high temperature measured in power unit's heatsink or board. Heatsink temperature is over 100°C.  | Check the correct amount and flow of cooling air.<br>Check the heatsink for dust.<br>Check the ambient temperature.<br>Make sure that the switching frequency is not too high in relation to ambient temperature and motor load. |
|            | 131      | AC drive overtemperature (alarm, heatsink) |   |  |
|            | 132      | AC drive overtemperature (fault, board)    |   |  |
|            | 133      | AC drive overtemperature (alarm, board)    |   |  |
| 15         | 140      | Motor stalled                              | Motor is stalled.   | Check motor and load.  |
| 16         | 150      | Motor overtemperature                      | Motor is overloaded.  | Decrease motor load.<br>If no motor overload exists, check the temperature model parameters.   |
| 17         | 160      | Motor underload                            | Motor is underloaded.   | Check load.  |
| 19         | 180      | Power overload (short-time supervision)    | Drive power is too high.  | Decrease load.   |
|            | 181      | Power overload (long-time supervision)     |   |  |
| 25         | 240      | Motor control fault                        | Start angle identification has failed.  | Reset the fault and restart.<br>Should the fault re-occur, contact the distributor near to you.  |
|            | 241      |  | Generic motor control fault.  |  |
| 26         | 250      | Start-up prevented                         | Start-up of the drive has been prevented. Run request is ON when a new software (firmware or application), parameter setting or any other file, which has affects the operation of the drive, has been loaded to drive. | Reset the fault and stop the AC drive.<br>Load the software and start the AC drive.  |

Table 40. Fault codes and descriptions.

| Fault code | Fault ID | Fault name                      | Possible cause   | Remedy  |
|------------|----------|---------------------------------|--|---|
| 30         | 290      | Safe off                        | Unstable STO input A (spurious pulses detected).   | Check the Safety switch and cabling. Reset the fault and restart. Should the fault re-occur, contact the distributor near to you.           |
|            | 291      | Safe off                        | Unstable STO input B (spurious pulses detected).   | Check the Safety switch and cabling. Reset the fault and restart. Should the fault re-occur, contact the distributor near to you.           |
|            | 520      | Safe diagnostic                 | Diagnostic failure (STO inputs are in different state).  | Check the Safety switch and cabling. Reset the fault and restart the drive. Should the fault re-occur, contact the distributor near to you. |
|            | 530      | STO fault                       | STO function demanded. Drive is in safe state.   | Wait for STO inputs deactivation. Reset the fault and restart.  |
| 32         | 312      | Fan cooling                     | Fan life time is up.   | Change fan and reset fan life time counter.   |
| 33         | 320      | Fire mode enabled               | Fire mode of the drive is enabled. The drive's protections are not in use.   | Check the parameter settings  |
| 37         | 360      | Device changed (same type)      | Option board changed for one previously inserted in the same slot. The board's parameter settings are saved.             | Device is ready for use. Old parameter settings will be used.   |
| 38         | 370      | Device changed (same type)      | Option board added. The option board was previously inserted in the same slot. The board's parameter settings are saved. | Device is ready for use. Old parameter settings will be used.   |
| 39         | 380      | Device removed                  | Option board removed from slot.  | Device no longer available.   |
| 40         | 390      | Device unknown                  | Unknown device connected (power unit/option board)   | Device no longer available.   |
| 41         | 400      | IGBT temperature                | IGBT temperature (unit temperature + I <sub>2</sub> T) is too high.  | Check loading. Check motor size. Make identification run.   |
| 44         | 430      | Device changed (different type) | Option board changed or Power unit changed. No parameter settings are saved.   | Set the option board parameters again if option board was changed. Set drive parameters again if power unit was changed.                    |
| 45         | 440      | Device changed (different type) | Option board added. The option board was not previously present in the same slot. No parameter settings are saved.       | Set the option board parameters again.  |
| 46         | 662      | Real Time Clock                 | RTC battery voltage level is low and the battery should be changed.  | Replace the battery.  |
| 47         | 663      | Software updated                | Software of the drive has been updated (either the whole software package or application).                               | No actions needed.  |

Table 40. Fault codes and descriptions.

| Fault code | Fault ID     | Fault name                   | Possible cause   | Remedy  |
|------------|--------------|------------------------------|--|---|
| 50         | 1050         | All low fault                | At least one of the available analogue input signals has gone below 50% of the defined minimum signal range. Control cable is broken or loose. Signal source has failed. | Change the failed parts. Check the analog input circuit. Check that parameter <i>A11 signal range</i> is set correctly.   |
| 51         | 1051         | External Fault               | Fault activated by digital input.  | Check the digital input or the device connected to it. Check the parameter settings.  |
| 52         | 1052<br>1352 | Keypad communication fault   | The connection between the control keypad and AC drive is broken   | Check keypad connection and possible keypad cable   |
| 53         | 1053         | Fieldbus communication fault | The data connection between the fieldbus master and fieldbus board is broken   | Check installation and fieldbus master.   |
| 54         | 1654         | Slot D fault                 | Defective option board or slot   | Check board and slot.   |
|            | 1754         | Slot E fault                 |  |   |
| 57         | 1057         | Identification               | Identification run has failed.   | Check that motor is connected to the drive. Ensure that there is no load on the motor shaft. Ensure that the start command will not be removed before completion of identification run.             |
| 58         | 1058         | Mechanical brake             | Actual status of mechanical brake remains different from the control signal for longer than what is defined.   | Check the status and connections of the mechanical brake.   |
| 61         | 1061         | Waiting restart time         | The drive is counting the delay time before a new attempt to start, after it stopped because of low power/voltage available from DC supply.                              | The delay can be skipped by turning off and on again the external Start command. Delay timing can be set with parameters from P3.22.1.2 to P3.22.1.4.   |
| 63         | 1063         | Quick Stop fault             | The Quick stop function is activated   | Find the cause for the quick stop activation. After you find it, correct it. Reset the fault and restart the drive. Once found and corrective actions taken, reset the fault and restart the drive. |
|            | 1367         | Quick Stop alarm             |  |   |
| 65         | 1065         | PC communication fault       | The data connection between the PC and AC drive is broken  |   |
| 66         | 1066         | Thermistor fault             | The thermistor input has detected an increase of motor temperature   | Check motor cooling and load. Check thermistor connection (If thermistor input is not in use it has to be short circuited)  |

Table 40. Fault codes and descriptions.

| Fault code | Fault ID | Fault name                       | Possible cause   | Remedy   |
|------------|----------|----------------------------------|--|--|
| 68         | 1301     | Maintenance counter 1 alarm      | Maintenance counter has reached the alarm limit.   | Carry out the needed maintenance and reset counter.  |
|            | 1302     | Maintenance counter 2 alarm      | Maintenance counter has reached the alarm limit.   | Carry out the needed maintenance and reset counter.  |
|            | 1303     | Maintenance counter 3 alarm      | Maintenance counter has reached the alarm limit.   | Carry out the needed maintenance and reset counter.  |
|            | 1304     | Maintenance counter 4 alarm      | Maintenance counter has reached the alarm limit.   | Carry out the needed maintenance and reset counter.  |
| 69         | 1310     | Fieldbus mapping error           | Non-existing ID number is used for mapping values to Fieldbus Process Data Out.  | Check parameters in Fieldbus Data Mapping menu.  |
|            | 1311     |                                  | Not possible to convert one or more values for Fieldbus Process Data Out.  | The value being mapped may be of undefined type. Check parameters in Fieldbus Data Mapping menu.   |
|            | 1312     |                                  | Overflow when mapping and converting values for Fieldbus Process Data Out (16-bit).  |  |
| 76         | 1076     | Start prevented                  | Start command is active and was blocked in order to prevent unintentional rotation of the motor during the first power-up. | Reset drive to restore the normal operation. The need of restart depends on the parameter settings.  |
| 77         | 1077     | >5 connections                   | Maximum number of 5 simultaneous active fieldbus or PC tool connections supported by the application exceeded.             | Remove excessive active connections.   |
| 100        | 1100     | Soft fill time-out               | The Soft fill function in the PID controller has timed out. The wanted process value was not achieved within time.         | Reason might be a pipe burst.  |
| 101        | 1101     | Process supervision fault (PID1) | PID controller: Feedback value outside of supervision limits (and the delay if set).                                       | Check settings.  |
| 105        | 1105     | Process supervision fault (PID2) | PID controller: Feedback value outside of supervision limits (and the delay if set).                                       | Check settings.  |
| 109        | 1109     | Input pressure supervision       | Input pressure supervision signal has gone below the alarm limit.  | Check the process.   |
|            | 1409     |                                  | Input pressure supervision signal has gone below the fault limit.  | Check the parameters<br>Check the input pressure sensor and connections.   |
| 111        | 1315     | Temperature fault 1              | At least one of the selected temperature input signals has reached the alarm limit.  | Find the cause of temperature raise.<br>Check the temperature sensor and connections.<br>Check that the temperature input is hard wired if no sensor is connected. |
|            | 1316     |                                  | At least one of the selected temperature input signals has reached the fault limit.  |  |
| 112        | 1317     | Temperature fault 2              | At least one of the selected temperature input signals has reached the fault limit.  | See option board manual for further information.   |
|            | 1318     |                                  | At least one of the selected temperature input signals has reached the fault limit.  |  |



Table 40. Fault codes and descriptions.

| Fault code | Fault ID | Fault name        | Possible cause   | Remedy   |
|------------|----------|-------------------|--|--|
| 113        | 1113     | Pump running time | In the Multipump system, 1 or more of the pump runtime counters is above a user-specified alarm limit. | Do the necessary maintenance actions, reset the runtime counter and reset the alarm. See Pump running time counters. |
|            | 1313     |                   | In the Multipump system, 1 or more of the pump runtime counters is above a user-specified Fault limit  |  |
| 300        | 700      | Unsupported       | The application is not compatible (it is unsupported).   | Replace the application.   |
|            | 701      |                   | The option board or the slot is not compatible (it is unsupported).                                    | Remove the option board.   |

### 8.3 HEATER (ARCTIC OPTION)

#### 8.3.1 SAFETY

This manual contains clearly marked cautions and warnings which are intended for your personal safety and to avoid any unintentional damage to the product or connected appliances.

**Please read the information included in dangers carefully.**

**The optional heater allows the drive to operate in low temperature conditions down to -40°C. This option is intended to be installed inside the drive.**

**Only trained and qualified personnel authorized by the manufacturer are allowed to install and maintain this component.**

#### 8.3.2 DANGERS



|   |   |
|---|---|
|  | The components of the optional heater are live when the element is connected to mains potential. Coming into contact with this voltage is extremely dangerous and may cause death or severe injury. |
|  | The heater can be used only inside the drive and in combination with only the VACON® 100 X. Before connecting the heater to mains, make sure that the VACON® 100 X drive is closed firmly.          |

Table 41. Dangers

#### 8.3.3 TECHNICAL DATA

The optional heater has to be supplied with single-phase 230V. The thermal element is always supplied and if the drive is connected at -40°C the drive will be heated up until the temperature of -10°C is exceeded. The heating is temperature controlled and an internal fan ensures that the air is equally distributed inside the enclosure.

The integrated relay output (switching capacity: 24VDC / 3A, 277VAC / 3A) can be used to control the power-up of the drive. The contact is closed when the internal temperature is higher than the minimum allowed value for the power-up (~ -10°C). This can be included and managed in the logic of the entire system. A bi-color LED (on the enclosure of this option), shows the status of the drive, ready or not-ready.

Table 42. Technical information on input and relay terminals.

| Heater connections |                       |  |
|--------------------|-----------------------|--|
| Terminal           | Signal                | Technical information  |
| <b>L1</b>          | Line                  | Supply voltage input terminals:<br>1AC 230V 50Hz 60 Hz<br>900 mA<br>Tolerance: 208V -15%...250V +10%<br>External fuse needed: <ul style="list-style-type: none"> <li>• class T (UL&amp; CSA) min. 300V</li> <li>• class J (UL&amp; CSA) min. 300V</li> </ul> |
| <b>N</b>           | Neutral               |  |
| <b>X1</b>          | Feedback relay output | Switching capacity:<br>24VDC / 3A<br>250VAC /3A  |

**8.3.4 FUSES**

The recommended fuse types for the heater supply voltage are shown in the table below.

*Table 43. Fuses ratings.*

| Fuses for heater supply voltage input - 230VAC |                           |                           |
|--|---------------------------|---------------------------|
| gG/gL (IEC 60269-1)<br>500V                    | class T (UL& CSA)<br>300V | class J (UL& CSA)<br>300V |
| 1A   | 1A                        | 1A                        |

*Table 44. Order codes for VACON® 100 X Heater*

| Order code    | Description                                   | Option type  |
|---------------|---|--------------|
| ENC-QAFH-MM04 | VACON®100 X MM4 Auxiliary Frame Heater option | Loose Option |
| ENC-QAFH-MM05 | VACON®100 X MM5 Auxiliary Frame Heater option | Loose Option |
| ENC-QAFH-MM06 | VACON®100 X MM6 Auxiliary Frame Heater option | Loose Option |

**8.3.5 MOUNTING INSTRUCTIONS: MM4 EXAMPLE**

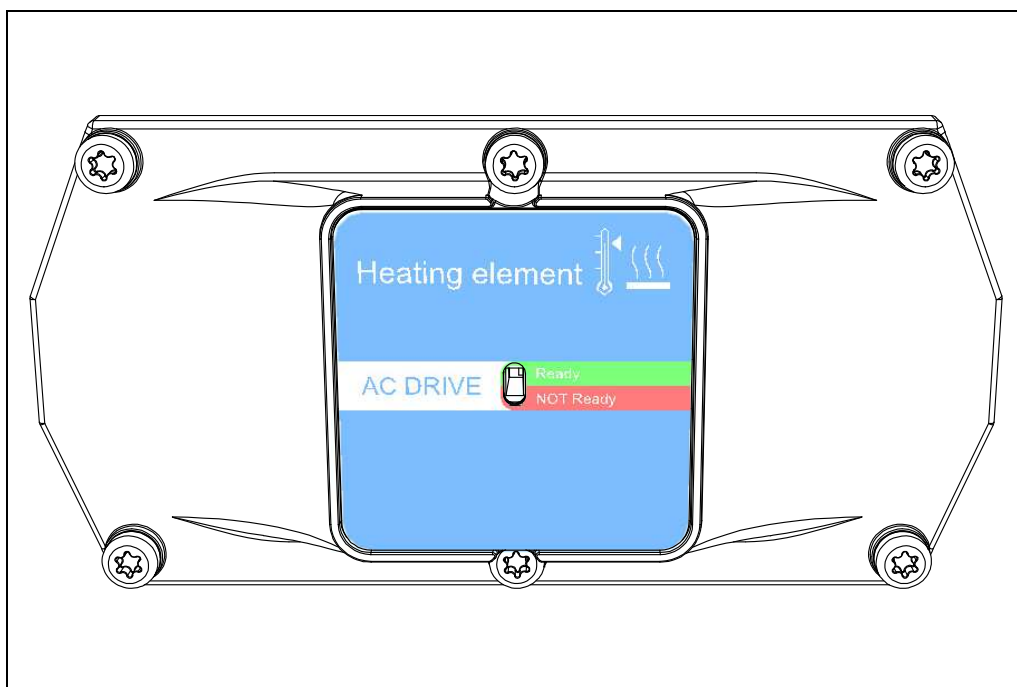

*Figure 76. Heater option for MM4*

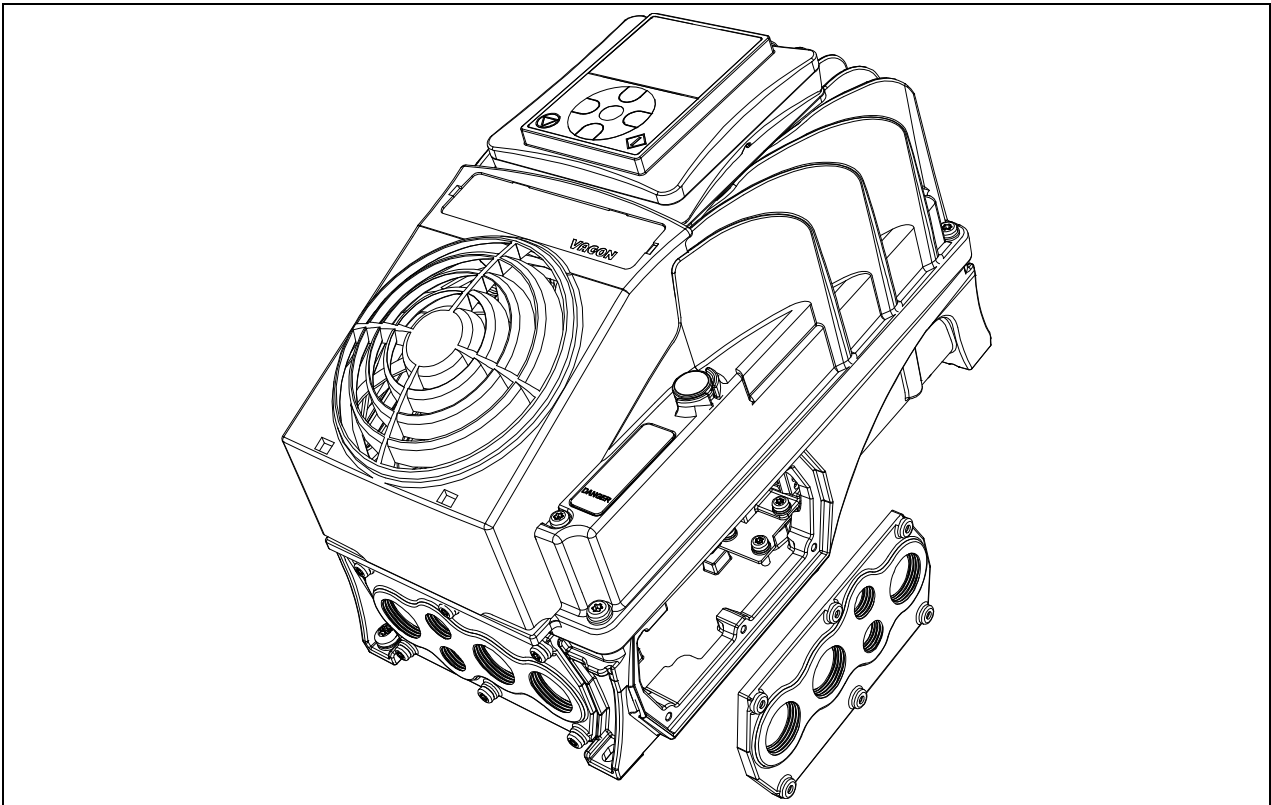

Figure 77. Remove the cable entry plate (right side example)

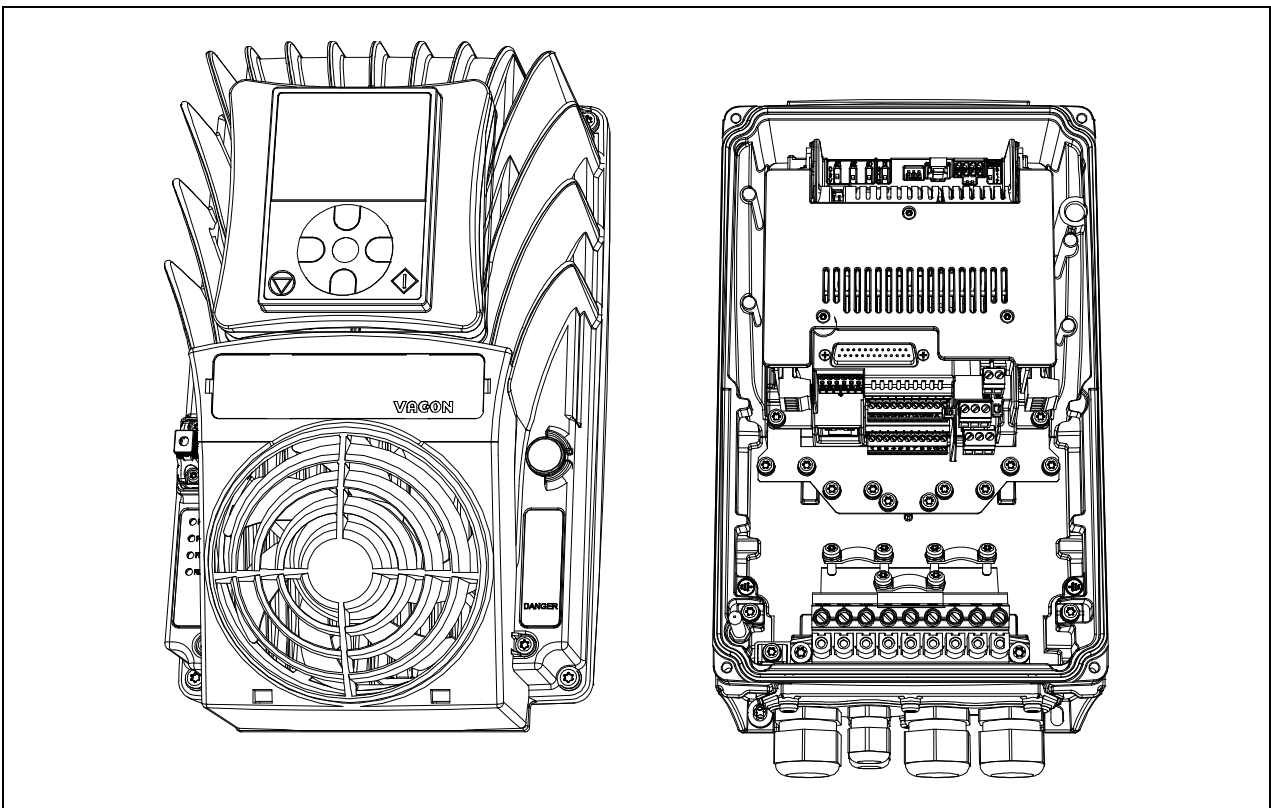

Figure 78. Remove the powerhead from the terminal box

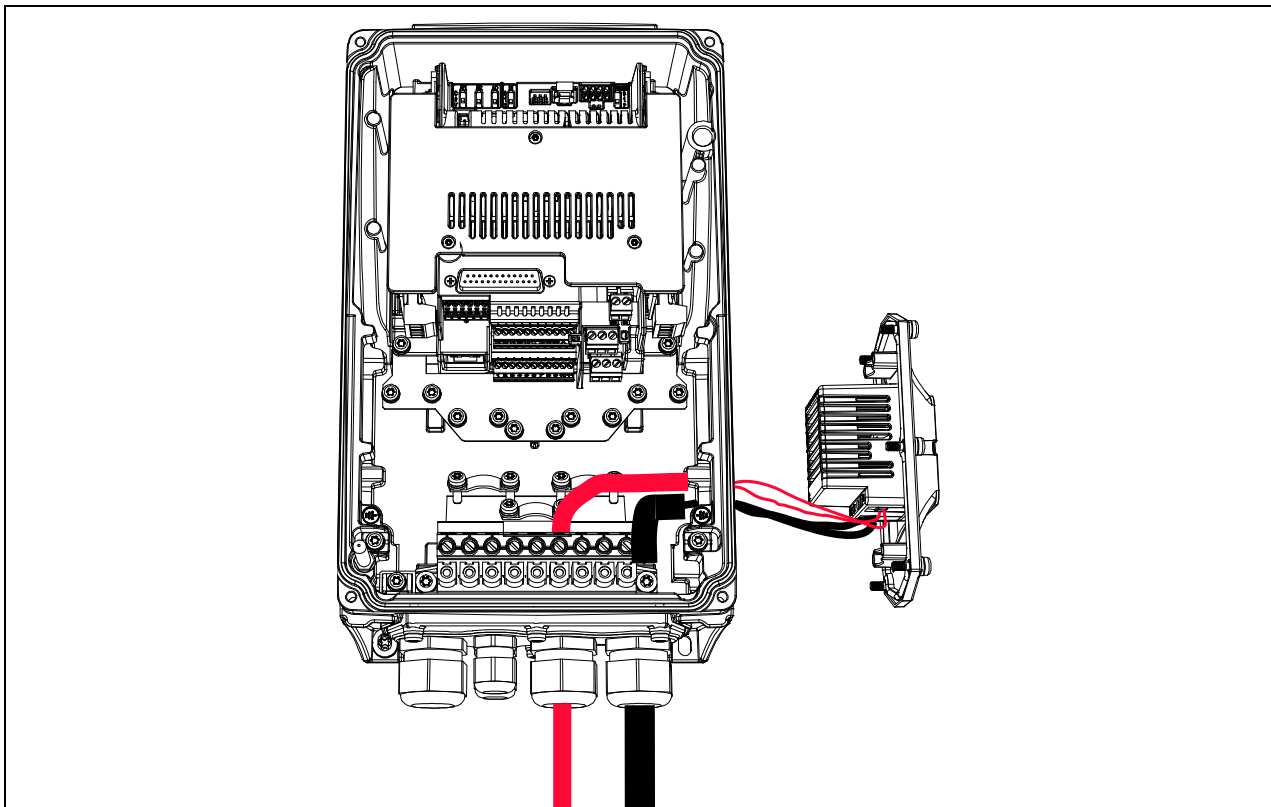

Figure 79. Connect the supply voltage (black cable) and the output relay (red cable) to the optional heater through the bottom cable entry plate. Color of the cables is only an example

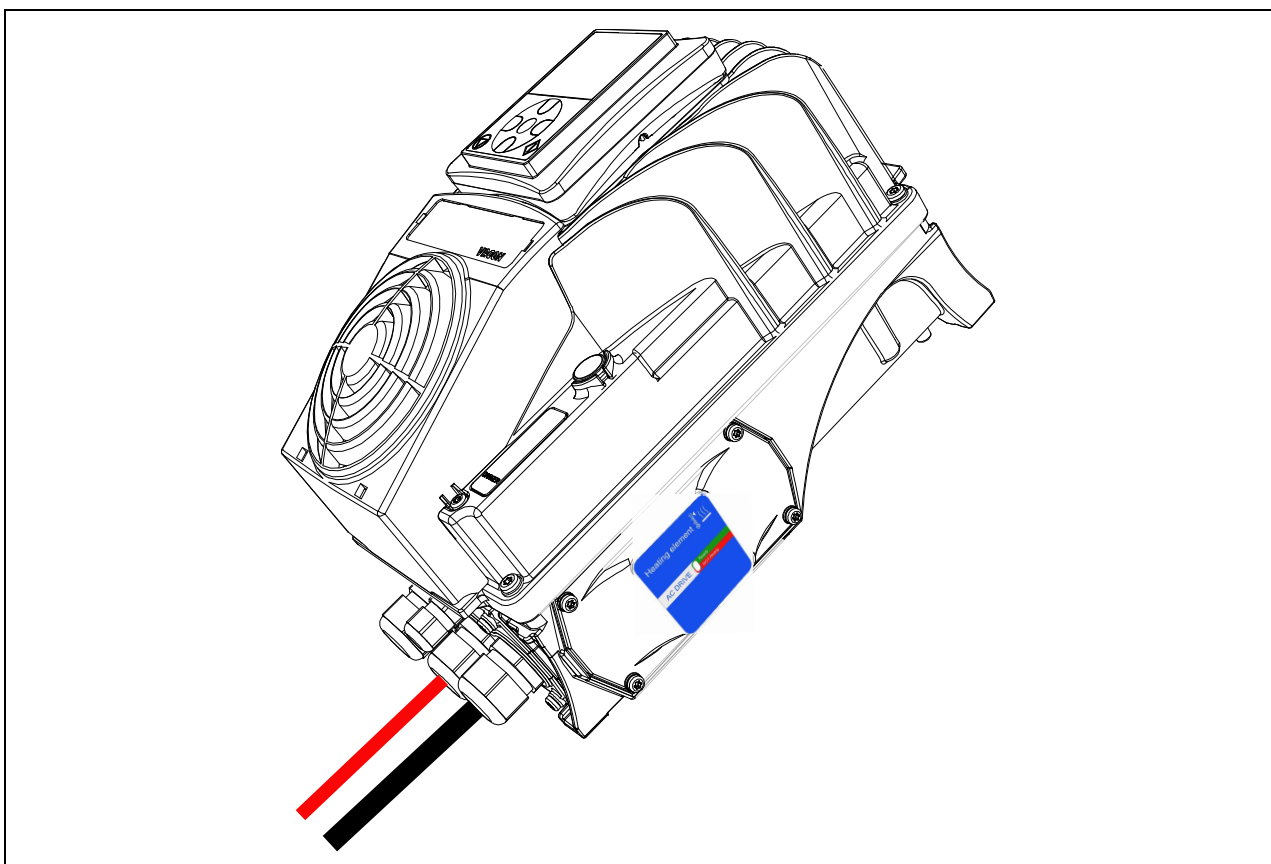

Figure 80. Mount the optional heater on the terminal box and then close the powerhead

## 8.4 OPTION BOARDS

VACON<sup>®</sup> 100 X drive family embodies a wide selection of expander boards with which the available I/O of VACON<sup>®</sup> 100 X AC drive can be increased and its versatility improved.

There are two board slots (labelled D and E) on the VACON<sup>®</sup> 100 X control board. To locate the slot, see chapter 5. Usually, when the AC drive is delivered from the factory, the control unit does not include any option board in the board slots.

The following option boards are supported:

*Table 45. Option boards supported in VACON<sup>®</sup> 100 X.*

| Code  | Description   | Note  |
|-------|---|---|
| OPTB1 | Option board with six bidirectional terminals.  | With jumper blocks it is possible to use each terminal as digital input or as digital output. |
| OPTB2 | I/O expander board with a thermistor input and two relay outputs.   |   |
| OPTB4 | I/O expander board with one galvanically isolated analogue input and two galvanically isolated analogue outputs (standard signals 0(4)...20mA). |   |
| OPTB5 | I/O expander board with three relay outputs   |   |
| OPTB9 | I/O expander board with five 42...240 VAC digital inputs and one relay output.  |   |
| OPTBF | I/O expander board with analogue output, digital output and relay output.   | On the OPTBF board, there is one jumper block for selecting the analogue output mode (mA/V).  |
| OPTBH | Temperature measurement board with three individual channels.   | Supported sensors: PT100, PT1000, NI1000, KTY84-130, KTY84-150, KTY84-131                     |
| OPTBK | AS-interface option board   |   |
| OPTC4 | LonWorks option board   | Pluggable connector with screw terminals  |
| OPTE2 | Modbus RTU and N2   | Screw terminals   |
| OPTE3 | PROFIBUS DP option board  | Pluggable connector with screw terminals  |
| OPTE5 | PROFIBUS DP option board  | 9-pin Sub-D terminal  |
| OPTE6 | CANopen option board  |   |
| OPTE7 | DeviceNet option board  |   |
| OPTE8 | Modbus RTU and N2   | Sub-D9 connector  |
| OPTE9 | Dualport Ethernet option board  |   |
| OPTEC | EtherCAT option board   |   |

See the Option boards User's Manual to use and install the option boards.

## 8.5 FLANGE ADAPTER

VACON® 100 X is an IP66/Type 4X outdoor drive, designed to be installed as close as possible to the motor, minimizing the use of electrical rooms, integrating the drive as part of the machine, without the use of cabinets.

VACON® 100 X drives are products that can be mounted directly onto the motor, machine or wherever the most efficient location for the drive is. This solution allows the machine designer, to use the available space in and around the machine, optimally. A decentralized solution provides a more flexible solution as an OEM manufacturer can deliver its machine in one piece, and there is no need to install the drives in a separate location. See the MM4 flange adapter in Figure 81.

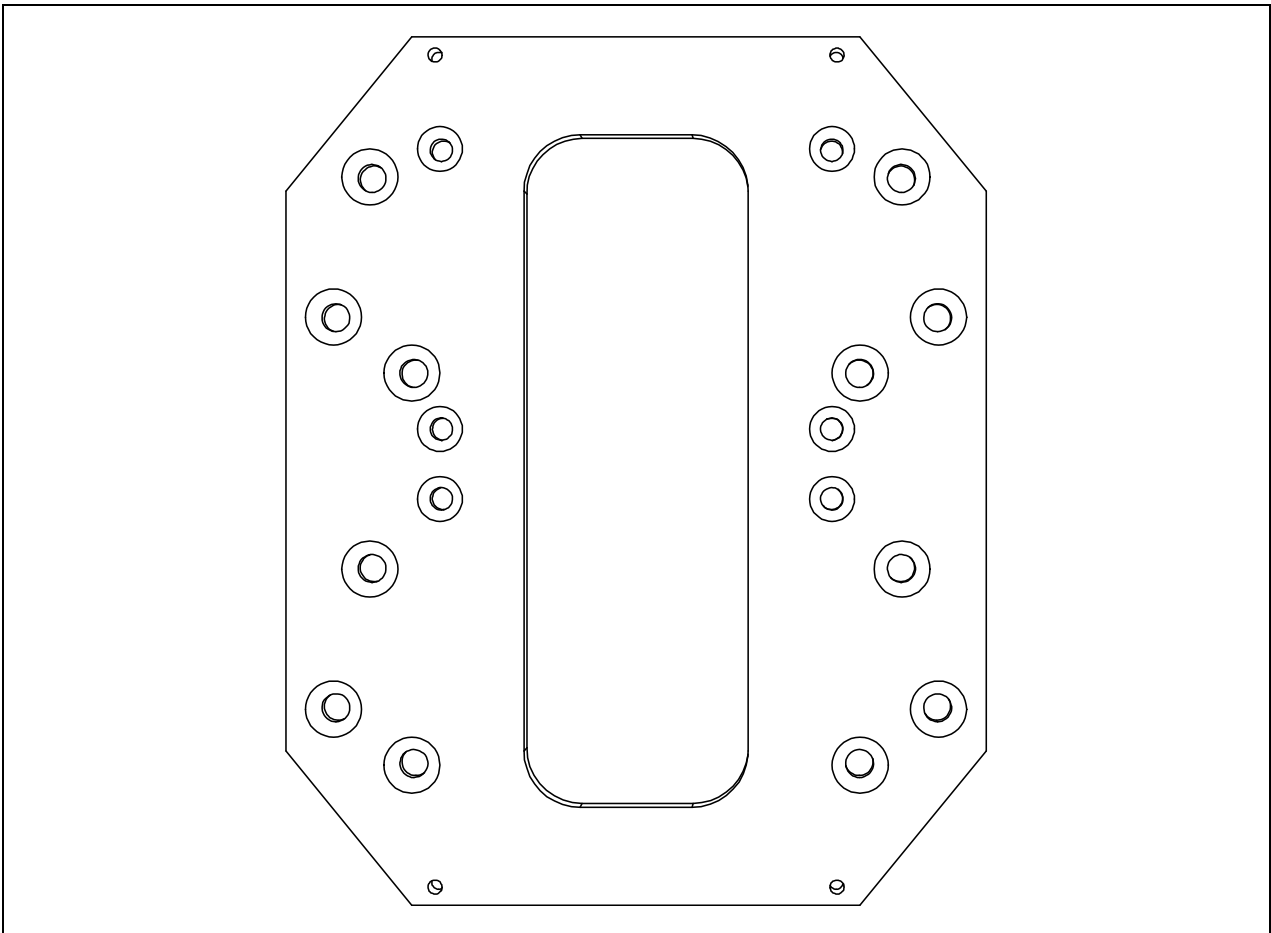

Figure 81. Flange adapter for MM4

These flange adapters can be used, for example, with the following motor types:

- B3 - Foot mounting
- B34 - Foot - B14 face mounting
- B35 - Foot - B5 flange mounting

Compared to a traditional solution, with the AC drives located in an electrical room, a decentralized solution offers significant savings potential in cabling and installation costs. By locating the drive near the machine or onto the motor, the length of the motor cable will be minimized.

ENC-QMMF-MM04 flange adapter can be used with 5 different motor sizes while both ENC-QMMF-MM05 and ENC-QMMF-MM06 flange adapters can be connected only to 3 different motor sizes. See Table 46 for further details.

Table 46 shows the corresponding flange adapters for different motor sizes. See also the relations with the inverter enclosure sizes.

Table 46. Correspondences between flange adapters, motors and inverter sizes.

| Flange adapter type code | Motor size | Power at 1500 rpm [kW] | Rated current at 1500 rpm [A] | A [mm] | B [mm] | Inverter enclosure size |
|--------------------------|------------|------------------------|-------------------------------|--------|--------|-------------------------|
| ENC-QMMF-MM04            | 90S        | 1.1                    | 2.89                          | 140    | 100    | MM4                     |
|                          | 90L        | 1.5                    | 3.67                          | 140    | 125    |                         |
|                          | 100L       | 2.2/3                  | 5.16/6.8                      | 160    | 140    |                         |
|                          | 112M       | 4                      | 8.8                           | 190    | 140    |                         |
|                          | 132S       | 5.5                    | 11.8                          | 216    | 140    |                         |
| ENC-QMMF-MM05            | 132M       | 7.5                    | 15.6                          | 216    | 178    | MM5                     |
|                          | 160M       | 11                     | 22.6                          | 254    | 210    |                         |
|                          | 160L       | 15                     | 30.1                          | 254    | 254    |                         |
| ENC-QMMF-MM06            | 180M       | 18.5                   | 36.1                          | 279    | 241    | MM6                     |
|                          | 180L       | 22                     | 42.5                          | 279    | 279    |                         |
|                          | 200L       | 30                     | 57.4                          | 318    | 305    |                         |

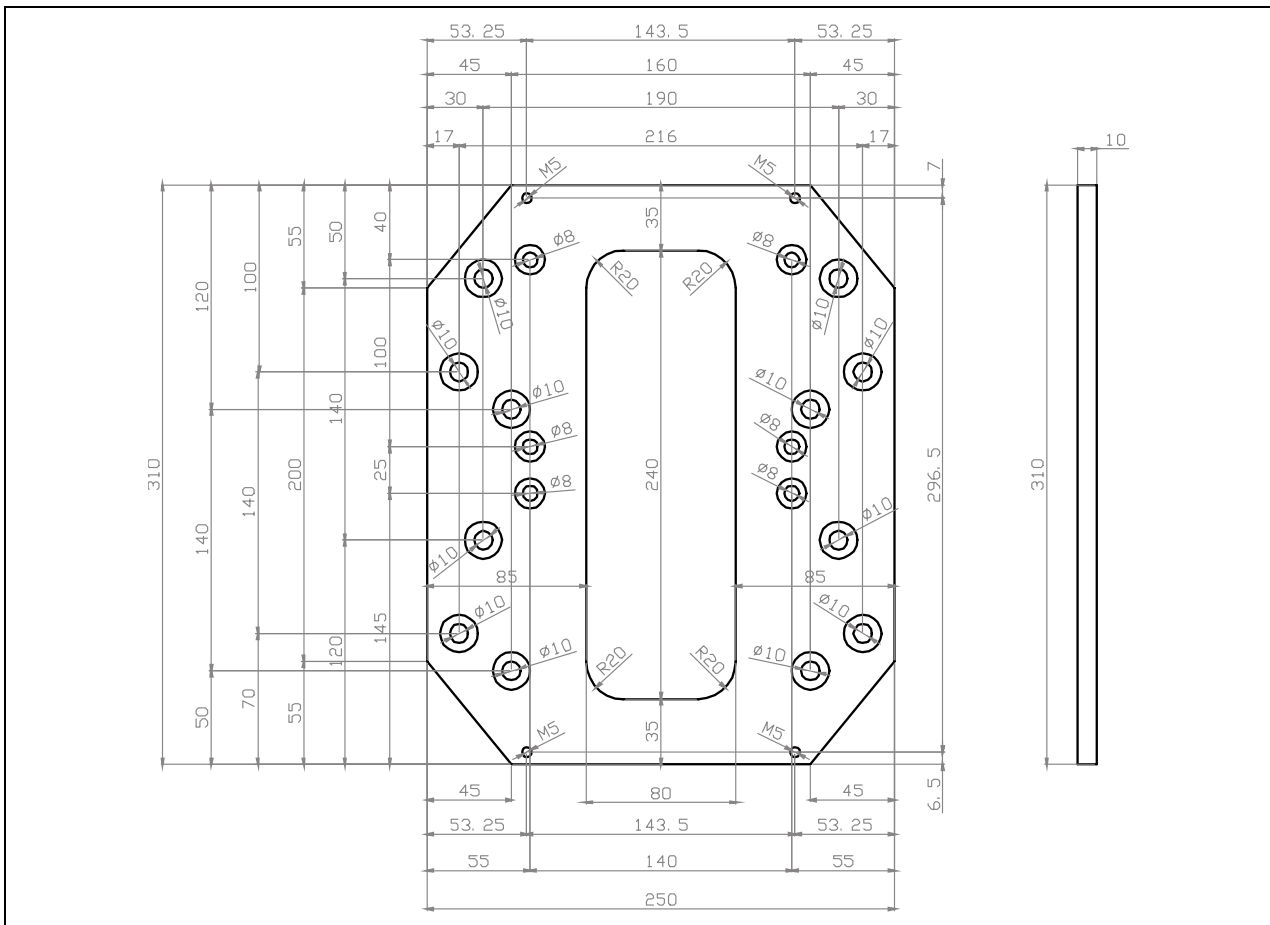

Figure 82. MM4 flange adapter dimensions



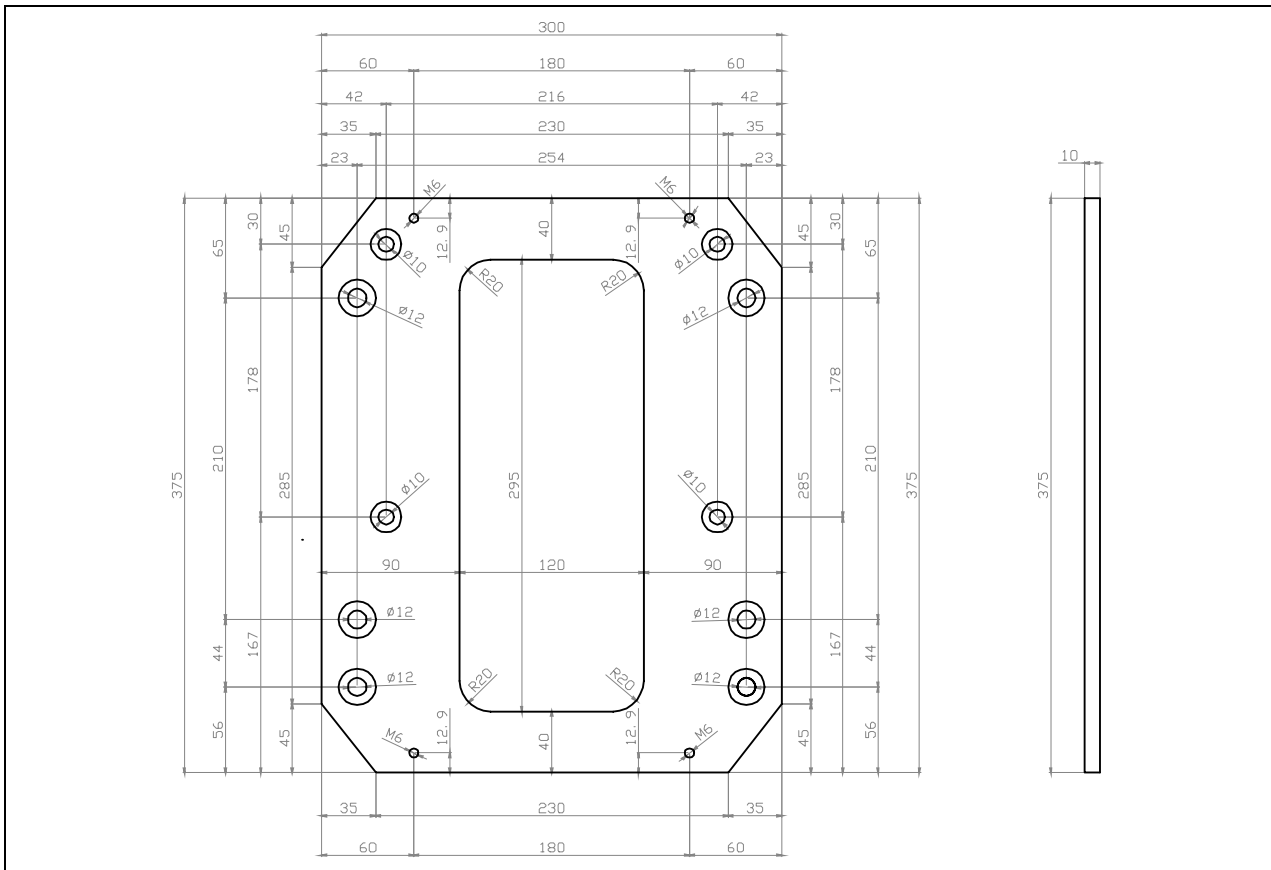

Figure 83. MM5 flange adapter dimensions

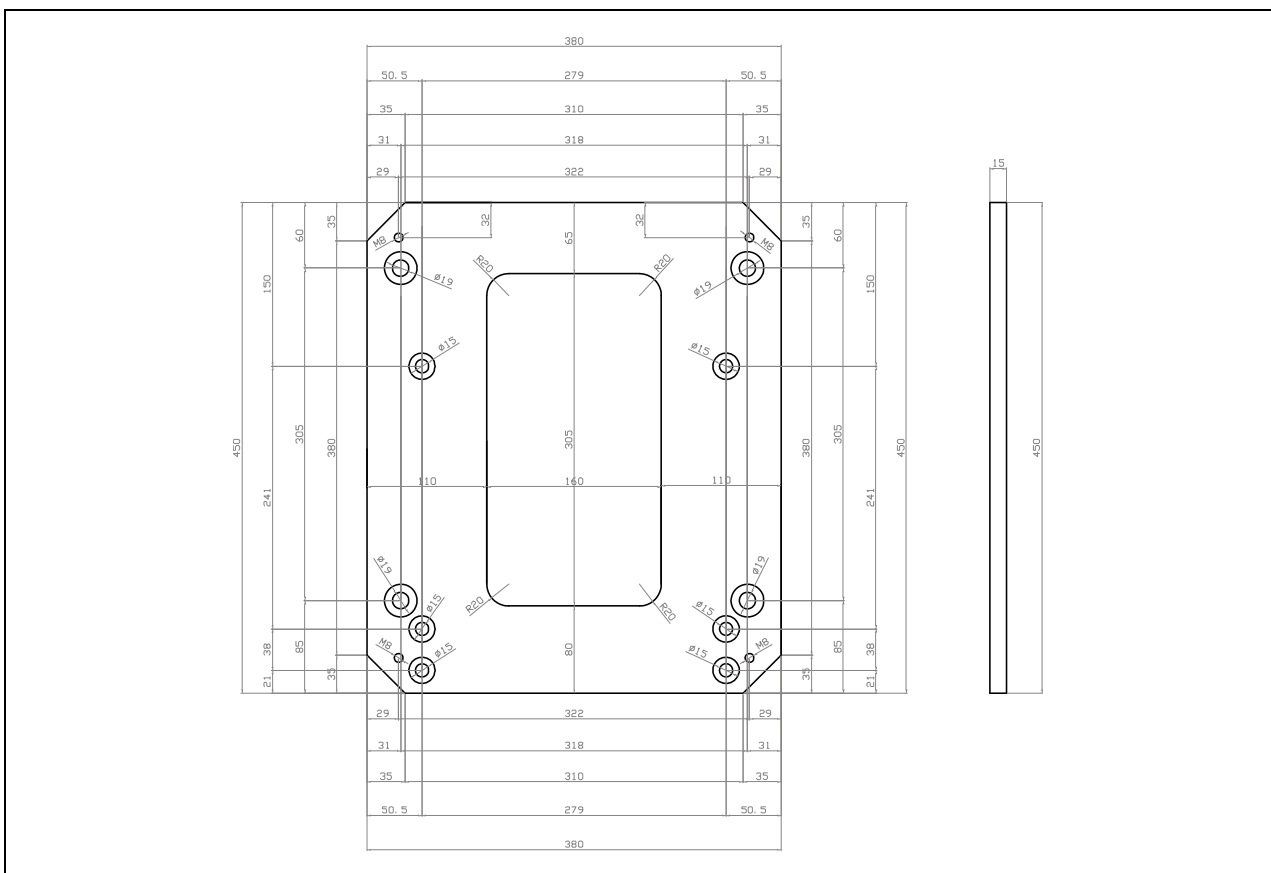

Figure 84. MM6 flange adapter dimensions

8.5.1 MOUNTING INSTRUCTIONS: MM4 EXAMPLE

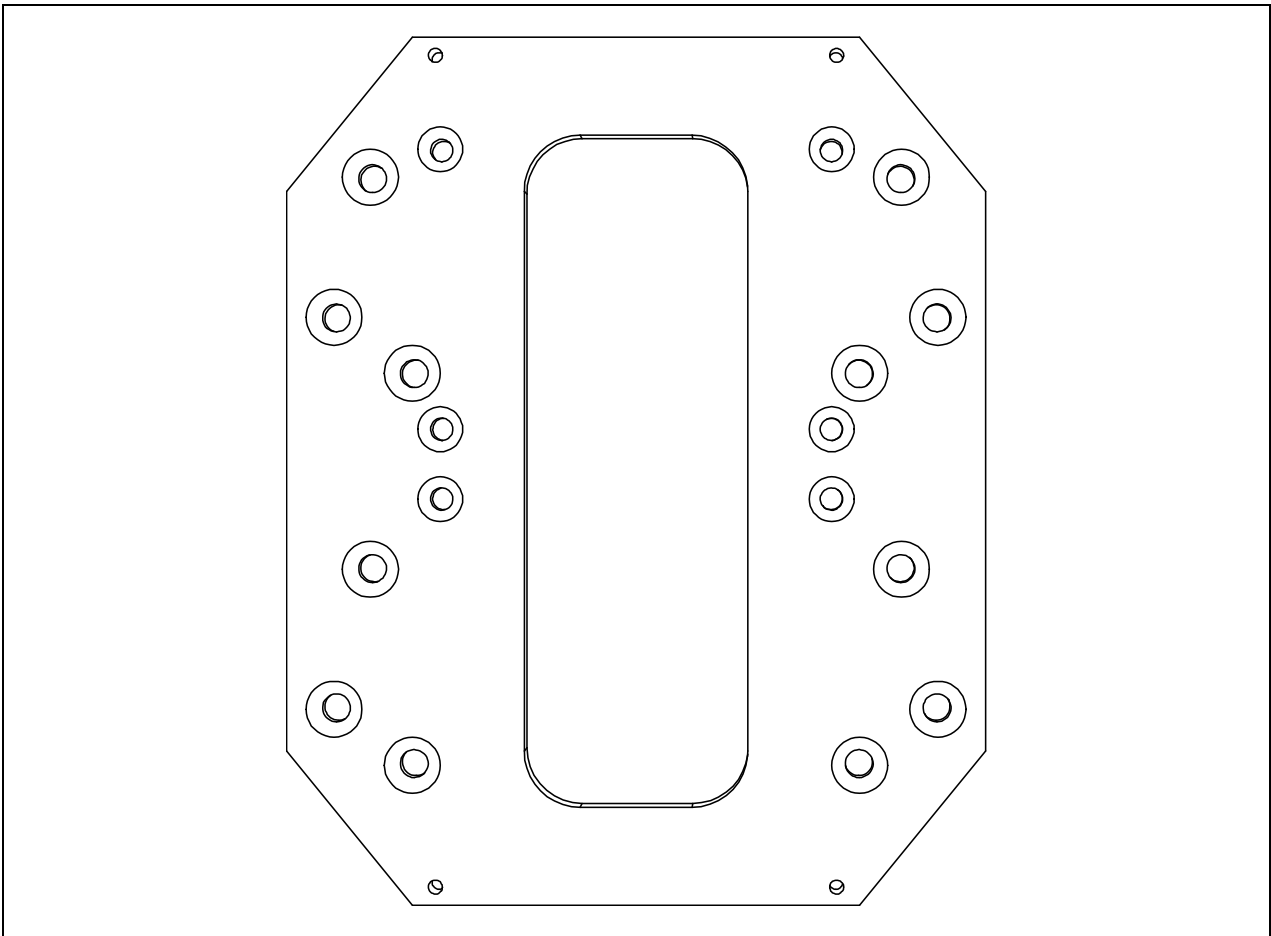

Figure 85. Flange adapter for MM4

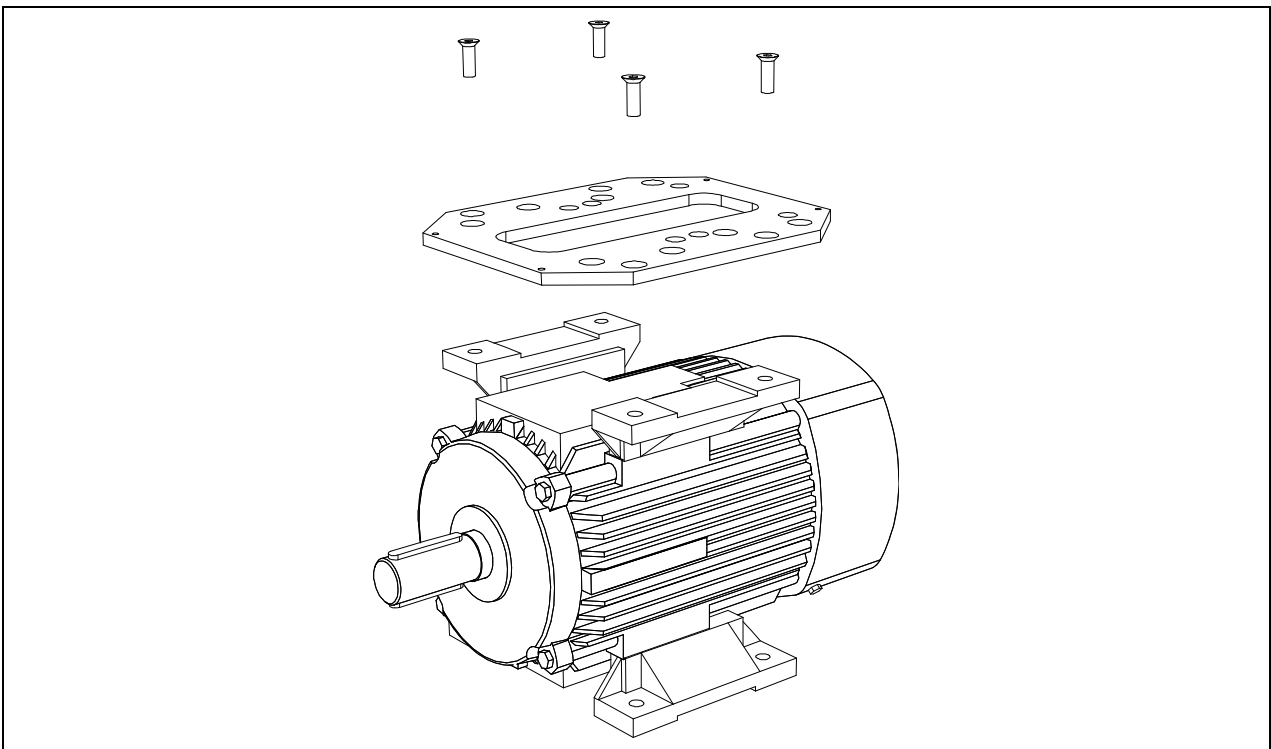

Figure 86. Mount the flange adapter on the motor

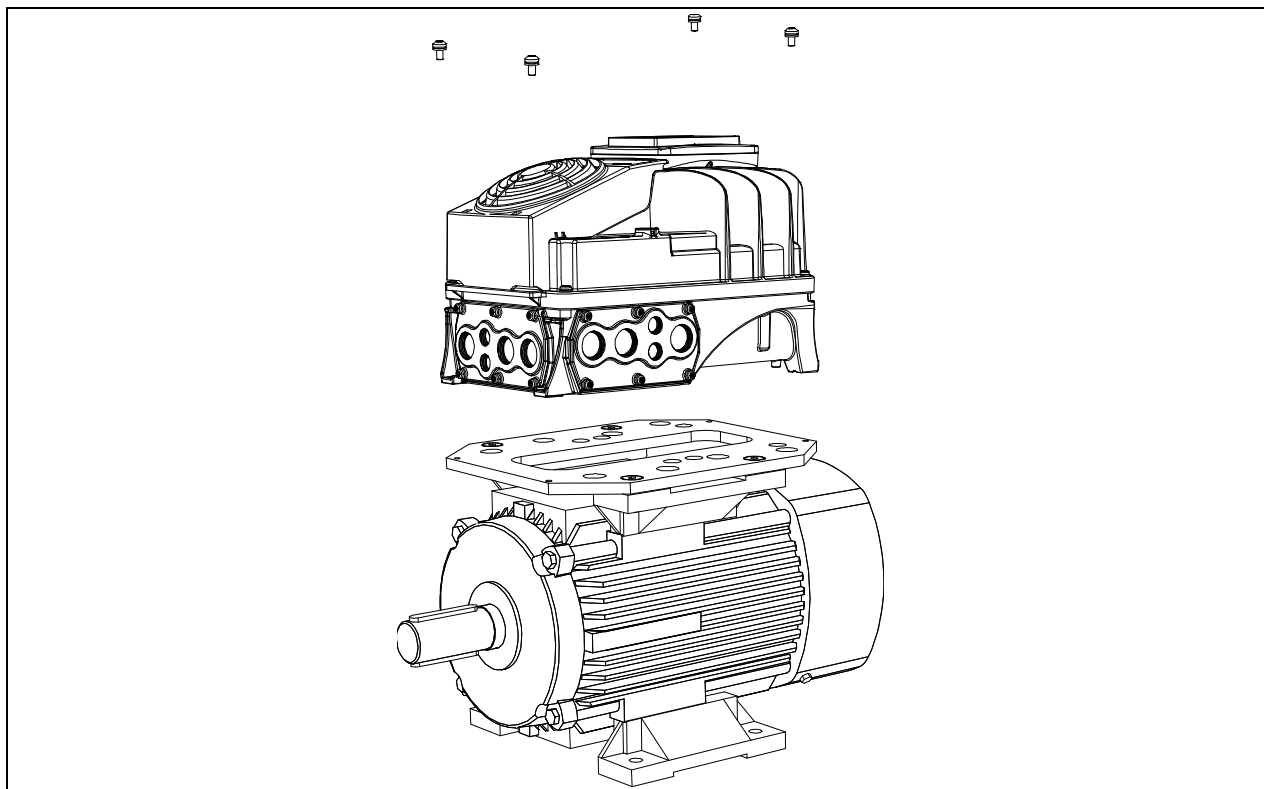

Figure 87. Mount the drive on the flange adapter using 4 screws

**NOTE:** Recommended screw type: countersunk head.

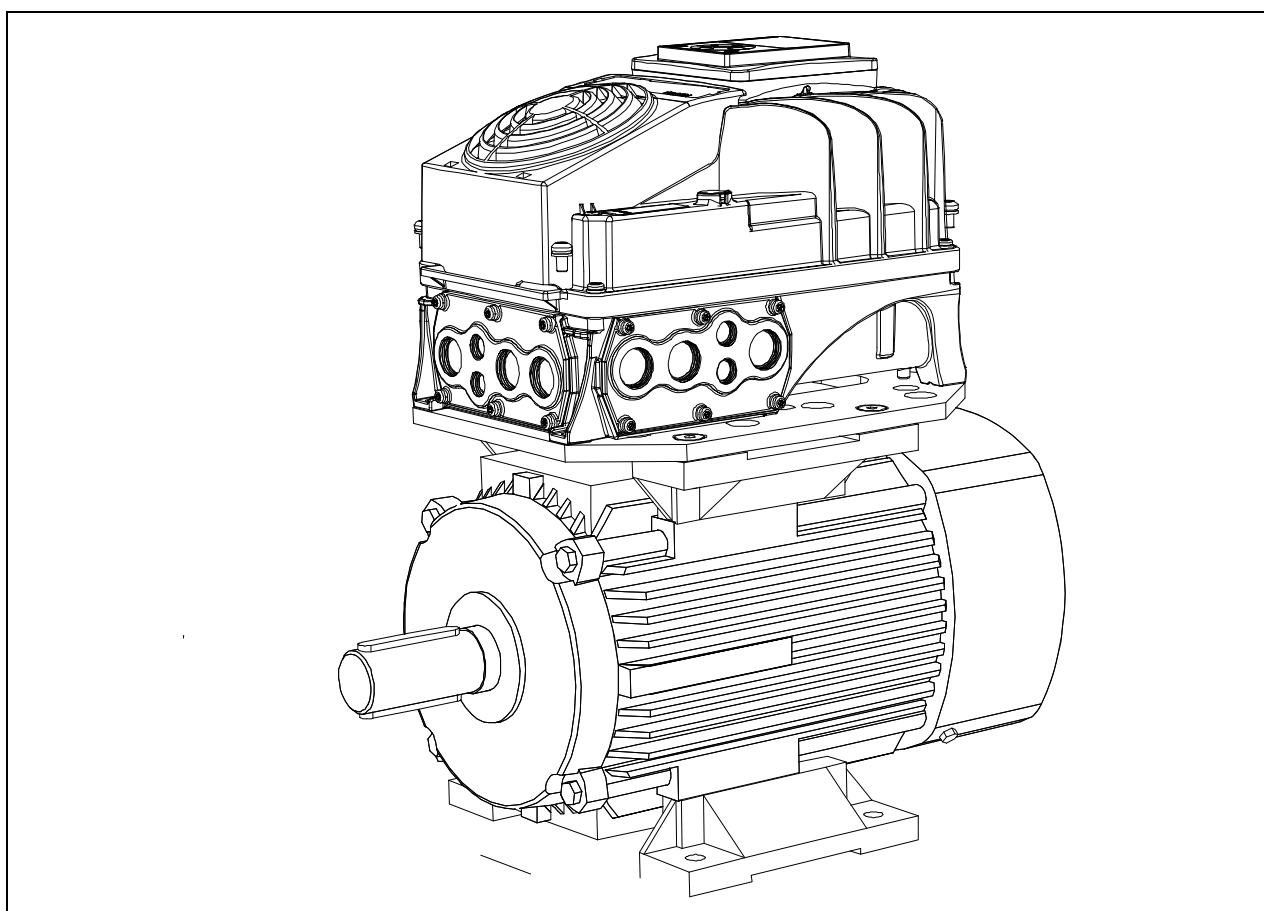

Figure 88. Drive mounted onto the motor

## 9. SAFE TORQUE OFF









This chapter describes the Safe Torque Off (STO) function which is a functional safety feature present into VACON® 100 X drive products as standard.

### 9.1 GENERAL DESCRIPTION

The STO function brings the motor in no-torque-state as defined by 4.2.2.2 of the IEC 61800-5-2: *"Power that can cause rotation (or motion in the case of a linear motor) is not applied to the motor. The Power Drive System (Safety Related) will not provide energy to the motor which can generate torque (or force in the case of a linear motor)."*

Therefore, the STO function is suitable for applications that rely on the immediate removal of power to the actuator, resulting in an uncontrolled coast to stop (activated by an STO demand). **Additional protective measures need to be applied when an application requires a different stop method.**

### 9.2 WARNINGS

|   |  |
|---|--|
|    | Designing of safety-related systems requires specialist knowledge and skills. Only qualified people are permitted to install and set up the STO function. The use of STO does not itself ensure safety. <b>An overall risk evaluation is required for ensuring that the commissioned system is safe.</b> Safety devices must be correctly incorporated into the entire system which must be designed in compliance with all relevant standards within the field of industry.               |
|   | The information in this manual provides guidance on the use of the STO function. This information is in compliance with accepted practice and regulations at the time of writing. However, the end product/system designer is responsible for ensuring that the <b>end-system</b> is safe and in compliance with relevant regulations.   |
|  | When a permanent magnet motor is used and in case of a multiple IGBT power semiconductor failure, when the STO option energizes the drive outputs to the off state, the drive system may still provide an alignment torque which maximally rotates the motor shaft by $180^\circ/p$ (where $p$ is the number of poles of the motor) before the torque production ceases.   |
|  | Electronic means and contactors are not adequate for protection against electric shock. The Safe Torque Off function does not disconnect the voltage or the mains from the drive. Therefore hazardous voltages may still be present on the motor. If electrical or maintenance work has to be carried out on electrical parts of the drive or the motor, the drive has to be completely isolated from the main supply, e.g. using an external supply disconnecting switch (see EN60204-1). |
|  | This safety function corresponds to an uncontrolled stop in accordance with stop category 0 of IEC 60204-1. The STO function does not comply with Emergency Switching Off according to IEC 60204-1 (no galvanic insulation from the Mains in case the motor is stopped).   |
|  | The STO function is not a prevention of unexpected start-up. To fulfill those requirements, additional external components are required according to appropriate standards and application requirements.   |
|  | In circumstances where external influences (e.g. falling of suspended loads) are present additional measures (e.g. mechanical brakes) may be necessary to prevent any hazard.  |
|  | STO must not be used as a control for starting or stopping the drive.  |

### 9.3 STANDARDS

The STO function has been designed for use in accordance with the following standards:

*Table 47. Safety Standards.*

| Standards            |
|----------------------|
| IEC 61508, Parts 1-7 |
| EN 61800-5-2         |
| EN 62061             |
| ISO 13849-1          |
| IEC 60204-1          |

The STO function has to be applied correctly to achieve the desired level of operational safety. Four different levels are allowed, depending on the use of the STO signals (see the following table).

*Table 48. Four different STO levels. (\*) see 9.5.1*

| STO inputs               | STO feedback | Cat. | PL | SIL |
|--------------------------|--------------|------|----|-----|
| Both dynamically used(*) | Used         | 4    | e  | 3   |
| Both statically used     | Used         | 3    | e  | 3   |
| Connected in parallel    | Used         | 2    | d  | 2   |
| Connected in parallel    | Not used     | 1    | c  | 1   |

The same values are calculated for SIL and SIL CL. According to EN 60204-1, the emergency stop category is 0.

The SIL value for the safety related system, operating in high demand/continuous mode, is related to the probability of dangerous failure per hour (PFH), reported in the following table.

*Table 49. SIL values. (\*) see 9.5.1.*

| STO inputs               | STO feedback | PFH          | PFDav    | MTTFd (years) | DCavg  |
|--------------------------|--------------|--------------|----------|---------------|--------|
| Both dynamically used(*) | Used         | 1.2 E-09 1/h | 1.0 E-04 | >4274 y       | HIGH   |
| Both statically used     | Used         | 1.2 E-09 1/h | 1.1 E-04 | >4274 y       | MEDIUM |
| Connected in parallel    | Used         | 1.2 E-09 1/h | 1.1 E-04 | >4274 y       | MEDIUM |
| Connected in parallel    | Not used     | 1.5 E-09 1/h | 1.3 E-04 | >4274 y       | NONE   |



**The STO inputs must always be supplied by a safety device.**

The power supply of the safety device may be external or taken from the drive (as long as this is compliant with the rating specified for terminal 6). See Chapter 5.1.2 for the standard I/O terminal description.

### 9.4 THE PRINCIPLE OF STO

The STO functionality, such as the technical principles and data (wiring examples and commissioning) will be described in this chapter.

In VACON® 100 X, the STO function is realized by preventing the propagation of the control signals to the inverter circuit.

The inverter power stage is disabled through redundant disabling paths which start from the two separated and galvanically isolated STO inputs (S1-G1, S2-G2 in Figure 89). In addition, an isolated output feedback is generated to improve the diagnostics of the STO function and to achieve a better safety capability (F+, F- terminals). The values assumed by the STO output feedback are indicated in the following table:

Table 50. Values of the STO output feedback (and torque on the motor). (\*) Only one channel is preventing the motor from moving.

| STO inputs                           | Operating conditions                       | STO feedback output      | Torque at the motor shaft        |
|--------------------------------------|--|--------------------------|----------------------------------|
| Both inputs energized with 24V DC    | Normal operation                           | The feedback must be 0V  | present (motor on)               |
| Power removed from both inputs       | STO demand                                 | The feedback must be 24V | disabled (motor de-energized)    |
| The STO inputs have different values | Failure in demand or due to internal fault | The feedback must be 0V  | disabled (motor de-energized)(*) |

The diagram below is a conceptual schematic diagram and is presented to illustrate the safety function with relevant safety components only shown.

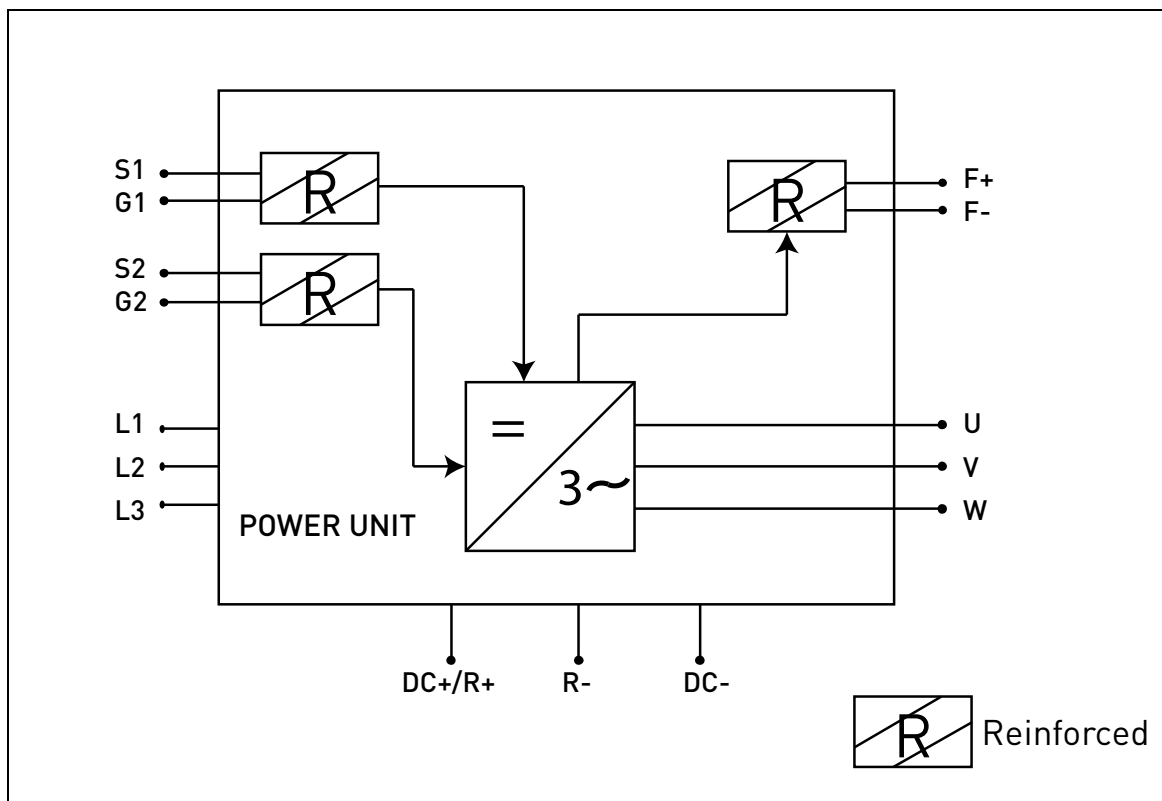

Figure 89. STO function principle

### 9.4.1 TECHNICAL DETAILS

The STO inputs are digital inputs intended for a nominal 24V d.c. input, positive logic (e.g. enabled when high).

Table 51. Electrical data.

| Technical information:            | Technical values   |
|-----------------------------------|--|
| Maximum voltage                   | 30 V   |
| Typical input current at 24V      | 10...15 mA   |
| Logic threshold                   | according to IEC 61131-2<br>15V...30V = "1"<br>0V...5V = "0" |
| Response time at nominal voltage: |  |
| Reaction time                     | <20ms  |

The reaction time of the STO function is the amount of time which passes from the moment in which the STO is activated until the system is in the Safe State. For VACON® 100 X, the reaction time is 20 ms maximum.

### 9.5 CONNECTIONS

To make the STO function available and ready to be used, both the STO jumpers have to be removed. They are located in front of the STO inputs to mechanically prevent the insertion of the STO connector. For the correct configuration, see the following table and the Figure 90.

Table 52. STO connector and data signals.

| Signal        | Terminal | Technical information  | Data                   |
|---------------|----------|--|------------------------|
| STO1          | S1       | Insulated digital input 1<br>(interchangeable polarity)                                  | 24V ±20%<br>10...15 mA |
|               | G1       |  |                        |
| STO2          | S2       | Insulated digital input 2<br>(interchangeable polarity)                                  | 24V ±20%<br>10...15 mA |
|               | G2       |  |                        |
| STO feed-back | F+       | Insulated digital output for STO<br>feedback<br>(CAUTION! Polarity must be<br>respected) | 24V ±20%<br>15 mA max. |
|               | F-       |  | GND                    |

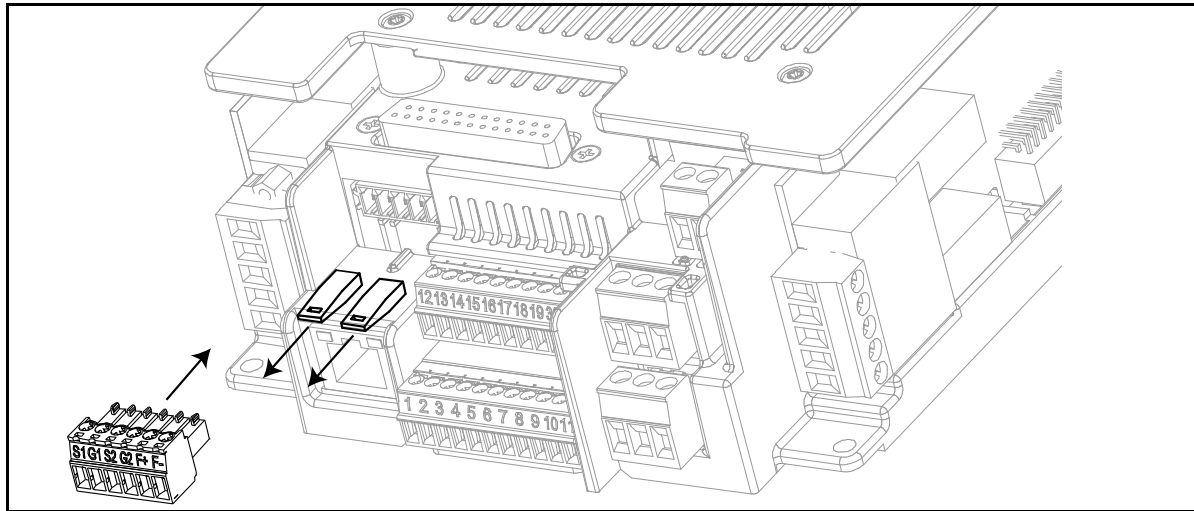

Figure 90. Removing the STO jumpers

|  |  |
|--|--|
|  | <p>Make sure that the AC drive is switched off before cabling.</p>   |
|  | <p>Disconnect both the STO jumpers to allow the cabling of the terminals.</p>  |
|  | <p>When the STO function is used, <b>the IP-class of the drive may not be reduced below IP54</b>. The IP-class of drive is IP66. It can be reduced by the wrong use of the cable entry plates or the cable glands.</p> |

The following examples show the basic principles for wiring the STO inputs and the STO output feedback. Local standards and regulations must be always followed in the final design.

**9.5.1 SAFETY CAPABILITY CAT. 4 / PL e / SIL 3**

For this safety capability, an external safety device must be installed. This must be used to dynamically activate the STO inputs and to monitor the STO output feedback.

The STO inputs are dynamically used when they do not commute together (static use), but according to the following picture (where the inputs are released with delay in turn). The dynamic use of the STO inputs allows detecting faults that may otherwise accumulate.



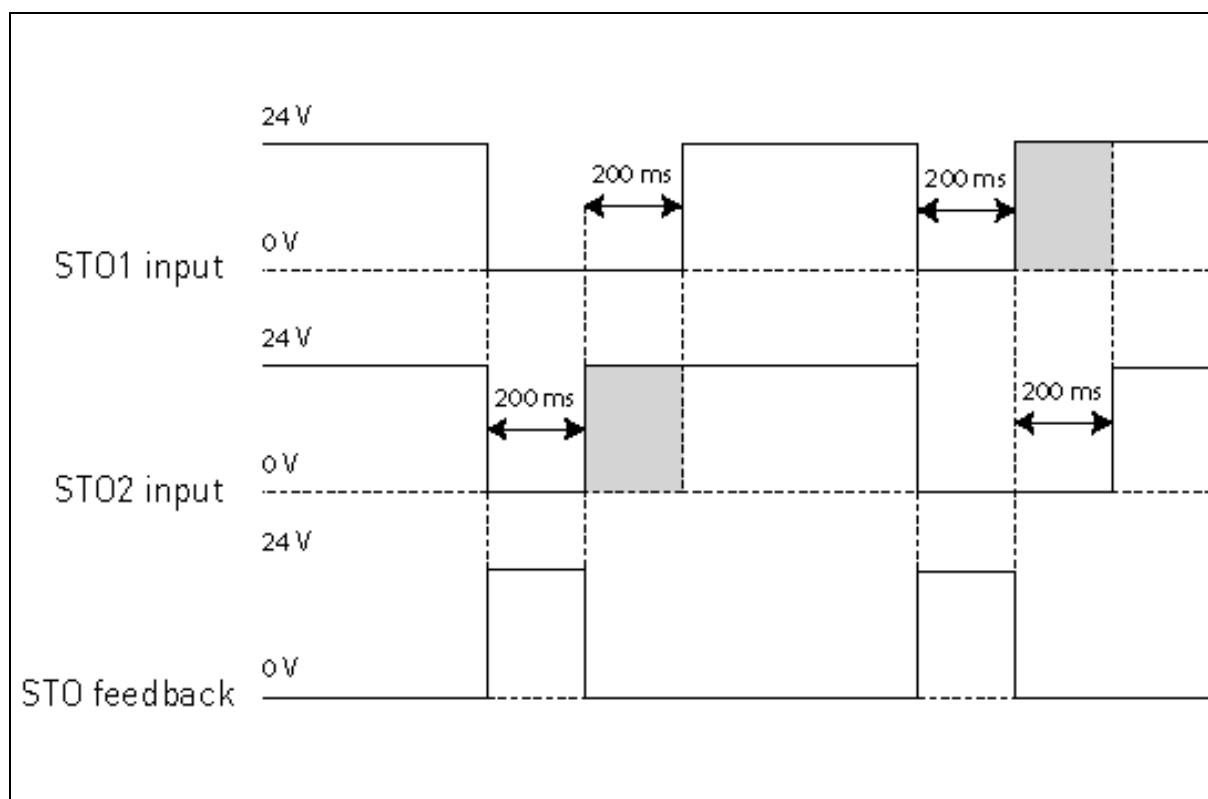

Figure 91.

|  |  |
|--|--|
|  | <p>An emergency push button connected to the STO inputs does not assure the same quality, because no fault detection is performed at a sufficient frequency (<b>once a day is recommended</b>).</p>      |
|  | <p>The external safety device, which forces the STO inputs and evaluates the STO output feedback, has to be a <b>safe device</b> and it has to fulfill the requirements of the specific application.</p> |
|  | <p>A simple switch cannot be used in this case!</p>  |

The picture below shows an example of connection for the STO function. The external device has to be connected with 6 wires to the drive.

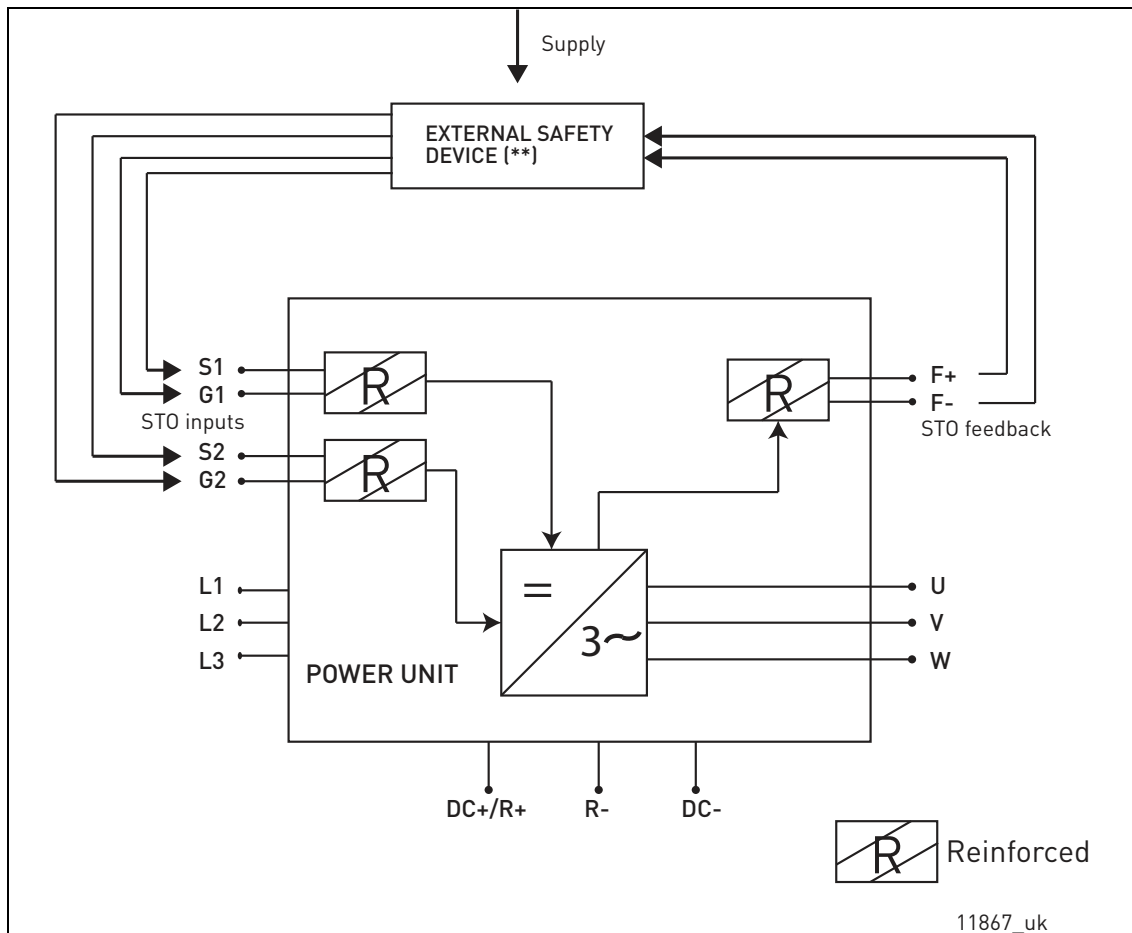

Figure 92. STO example with automatic monitoring of the feedback and both STO inputs used. (\*\*\*) The external safety device must feed active voltage to the STO inputs.

The external device has to monitor the STO function in accordance with the Table 50. The device has to periodically de-energize the STO inputs and it has to verify that the STO output feedback assumes the expected value.

Any difference between the expected and the real value has to be considered as a failure and has to drive the system into a Safe State. In case of failure, check the wiring. If the fault recognized by the external safety device persists, **the drive will have to be replaced/repaired.**

**9.5.2 SAFETY CAPABILITY CAT. 3 / PL e / SIL 3**

The safety capability is reduced to Cat. 3 / PL e / SIL 3 if the STO inputs are statically used (which means they are forced to commute together).

Both STO inputs and the STO feedback have to be used. The same warnings and cabling instruction as 9.5.1 apply, except that the proof test interval has to be at least once every three months.

### 9.5.3 SAFETY CAPABILITY CAT. 2 / PL d / SIL 2

The safety capability is reduced to Cat. 2 / PL d / SIL 2 if the STO inputs are connected in parallel (no redundancy of the STO inputs).

The STO feedback has to be used. The same warnings as in 9.5.1 apply, except the proof test interval has to be at least once a year. The picture below shows an example of connection for the STO function. The external device has to be connected with 4 wires to the drive.

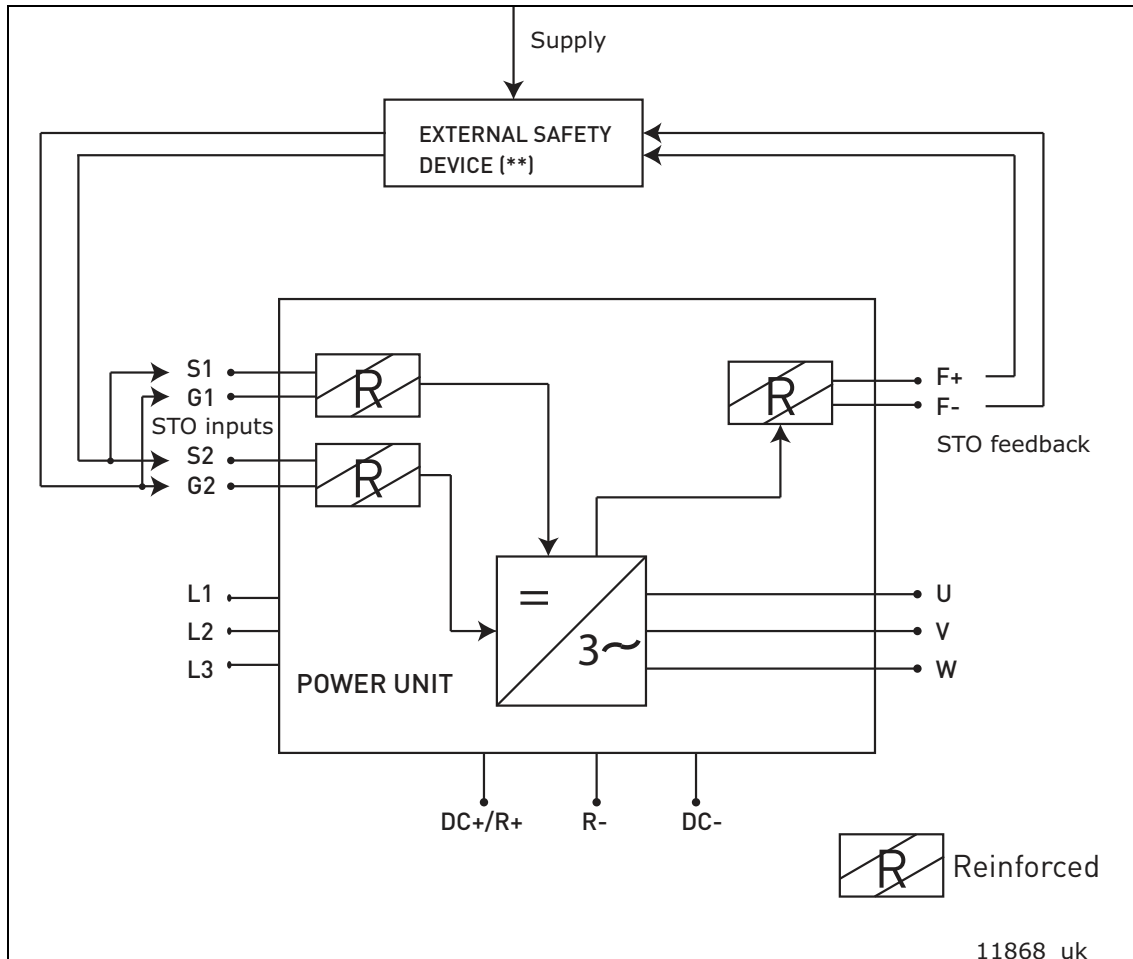





Figure 93. STO Example with automatic monitoring of the feedback and STO inputs connected in parallel. (\*\*) The external safety device must feed active voltage to the STO inputs.

9.5.4 SAFETY CAPABILITY CAT. 1 / PL c / SIL 1

Without any automatic monitoring of STO output feedback, the safety capability is reduced to Cat. 1 / PL c / SIL 1. The STO inputs (which can be connected in parallel) must be supplied by a safety push button or a safety relay.

|   |   |
|---|---|
|  | The choice of using the STO inputs (without the automatic monitoring of the output feedback) does not allow <b>other safety capabilities to be achieved</b> .   |
|  | The standards for functional safety require that functional proof tests are performed on the equipment at user-defined intervals. Therefore, <b>this safety capability</b> can be achieved, as long as the STO function is manually monitored at the frequency determined by the specific application ( <b>once a year can be acceptable</b> ). |
|  | This <b>safety capability</b> can be achieved by connecting in parallel the STO inputs externally and by ignoring the use of the STO output feedback.   |

The picture below shows an example of connection for the STO function. A switch (a safety push button or a safety relay) may be connected with 2 wires to the drive.

When the contacts of the switch are opened, the STO is demanded, the drive indicates F30 (=“Safe Torque Off”) and the motor stops by coasting.

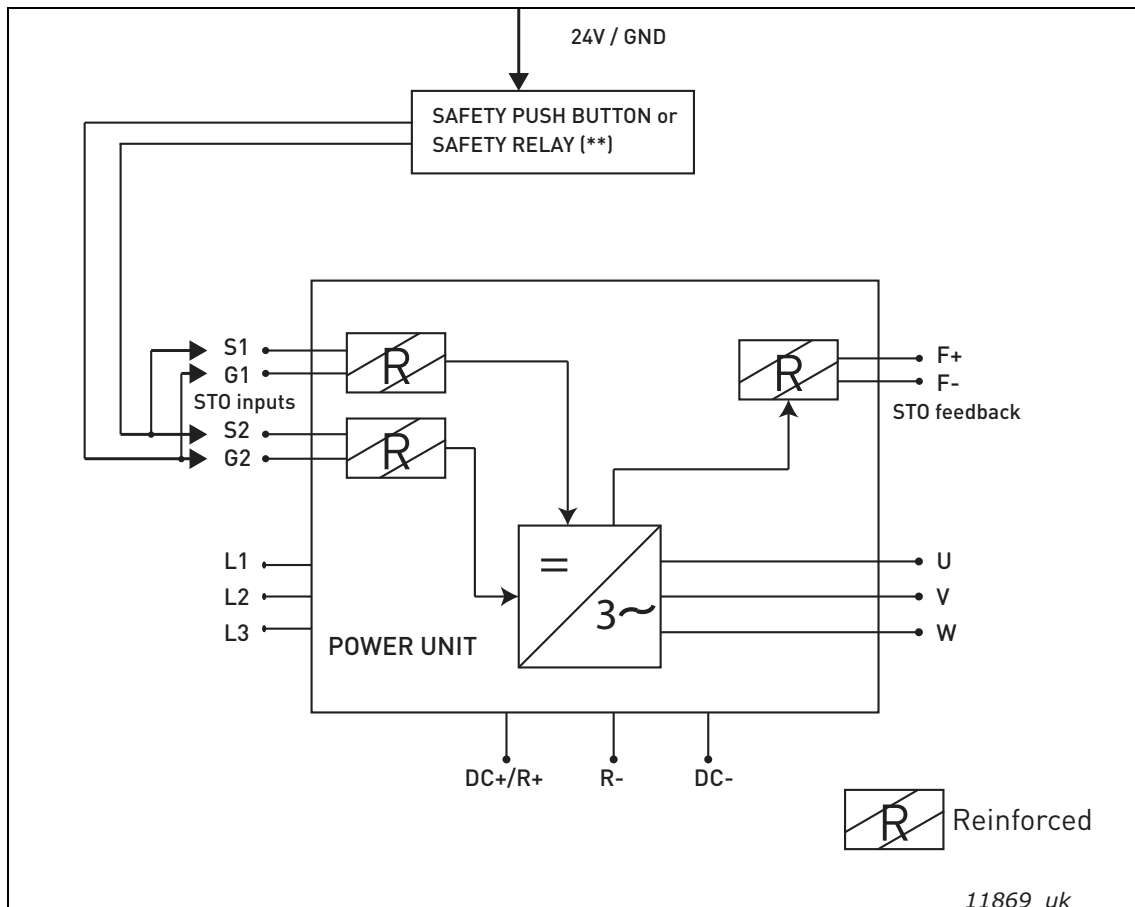



Figure 94. STO example without automatic monitoring of the feedback and STO inputs connect- ed in parallel. (\*\*) The safety push button or safety relay must feed active voltage to the STO inputs.

## 9.6 COMMISSIONING

### 9.6.1 GENERAL WIRING INSTRUCTIONS

|   |  |
|---|--|
|  | Protect the STO cabling with a shielding or an enclosure to exclude external damage. |
|  | Wires ferrules are highly recommended for all STO signals (inputs and feedback).     |

The wiring must be done according to the general wiring instructions for the specific product. A shielded cable is required. In addition, the voltage drop from the supply point to the load must not exceed 5% [EN 60204-1 part 12.5].

The following table indicates examples of cables to be used.

*Table 53. Cable types required to meet the standards. (\*) Additional wires are needed for restarting the drive after each STO demand.*

| STO feedback  | Cable size                            |
|---|---------------------------------------|
| STO feedback automatically monitored by an external safety device | 3 x (2 + 1) x 0.5 mm <sup>2</sup> (*) |
| STO feedback ignored, simply safety device (switch) used          | 2 x (2 + 1) x 0.5 mm <sup>2</sup>     |

### 9.6.2 CHECKLIST FOR COMMISSIONING



Follow the checklist shown in the table below for the steps required to use the STO function.

*Table 54. Checklist for commissioning of STO.*

|                          |   |
|--------------------------|---|
| <input type="checkbox"/> | Carry out a risk assessment of the system to ensure that the use of the STO function is safe and according to the local regulations.  |
| <input type="checkbox"/> | Include in the assessment an examination of whether the use of external devices, such as a mechanical brake, are required.  |
| <input type="checkbox"/> | Check if the switch (if used) has been chosen according to the required safety performance target (SIL/PL/Category) set during the risk evaluation.   |
| <input type="checkbox"/> | Check if the external device for automatic monitoring of the STO output feedback (if used) has been chosen in accordance with the specific application.   |
| <input type="checkbox"/> | Check if the reset function with the STO function (if used) is edge sensitive.  |
| <input type="checkbox"/> | The shaft of a permanent magnet motor might, in an IGBT fault situation, still provide energy before the torque production ceases. This may result in a jerk of max. 180° electrically. Ensure that the system is designed in such a way that this can be accepted. |
| <input type="checkbox"/> | Check if the degree of protection of the <b>enclosure is at least IP54</b> . See paragraph 9.5.   |
| <input type="checkbox"/> | Check if the recommendations on EMC for cables have been followed.  |
| <input type="checkbox"/> | Check if the system has been designed in such a way that enabling of the drive through STO inputs will not lead to an unexpected start of the drive.  |
| <input type="checkbox"/> | Check if only approved units and parts have been used.  |
| <input type="checkbox"/> | Set up a routine to ensure that the functionality of the STO function is being checked at regular intervals.  |

## 9.7 PARAMETERS AND FAULT TRACING



There are no parameters for the STO function itself.

|   |  |
|---|--|
|  | Before testing the STO function, make sure that the checklist (Table 54) is inspected and completed.     |
|  | When STO function activates, the drive always generates a fault ("F30") and the motor stops by coasting. |
|  | In the application the STO state can be indicated using a digital output.                                |

To re-enable motor operation, after the STO state, it is necessary to perform the following steps:

- Release the switch or the external device ("F30" is displayed even after this has been released).
- Reset the fault (through a digital input or from the keypad).
- It is possible that a new start command is required for the restart (depending on the application and your parameter settings).

## 9.8 MAINTENANCE AND DIAGNOSTICS

|   |   |
|---|---|
|  | If any service or repair is to be conducted on the drive installed, inspect the checklist given in Table 54.  |
|  | During maintenance breaks, or in case of service/repair, <b>ALWAYS</b> make sure that the STO function is available and fully functional by testing it. |

The STO function or the STO input/output terminals do not need any maintenance.

The following table shows faults that may be generated by the software that monitors the hardware related to the STO safety function. If you detect any failure in safety functions, including STO, contact your local supplier.

*Table 55. Fault related to the STO function.*

| Fault Code | Fault           | Cause  | Correction    |
|------------|-----------------|--|---------------|
| 30         | Safe Torque Off | STO inputs in a different state or both de-energized | Check cabling |

**NOTE!** See Table 40 for detailed fault code descriptions.

# VACON<sup>®</sup>

[www.danfoss.com](http://www.danfoss.com)

Vacon Ltd  
Member of the Danfoss Group  
Runsorintie 7  
65380 Vaasa  
Finland

Document ID:



DPD00534L

Rev. L