

ENGINEERING  
TOMORROW

*Danfoss*

Operating Guide

# VACON® NX Inverters FI4-FI8



[drives.danfoss.com](http://drives.danfoss.com)

**VACON®**



## Contents

<b>1</b>	<b>Introduction</b>	<b>8</b>
1.1	Purpose of this Operating Guide	8
1.2	Additional Resources	8
1.3	Disposal	8
1.4	Type Approvals and Certifications	8
1.5	Start up Quick Guide	9
<b>2</b>	<b>Safety</b>	<b>11</b>
2.1	Safety Symbols	11
2.2	Danger and Warnings	11
2.3	Cautions and Notices	13
<b>3</b>	<b>Product Overview</b>	<b>15</b>
3.1	Introduction	15
3.2	Intended Use	16
3.3	Manual Version	16
3.4	Standard Features of VACON NX Inverters	17
3.5	Package Label	17
3.6	Description of the Type Code	18
3.7	Enclosure Sizes	20
3.8	Available Protection Ratings	21
3.9	Available EMC Classes	22
3.10	Control Panel	22
	3.10.1 Keypad	22
	3.10.2 Display	23
	3.10.3 Basic Menu Structure	24
<b>4</b>	<b>Receiving the Delivery</b>	<b>26</b>
4.1	Checking the Delivery	26
4.2	Storing the Product	28
4.3	Lifting the Product	28
4.4	Using the Product Modified Label	28
<b>5</b>	<b>Mounting the Unit</b>	<b>30</b>
5.1	Environmental Requirements	30
	5.1.1 General Environmental Requirements	30
	5.1.2 Ambient Temperature and Derating	30
	5.1.3 High Altitude Installation	31
5.2	Cooling Requirements	32
	5.2.1 General Cooling Requirements	32

5.2.2	Cooling of FI4 to FI8	32
5.3	Installation Sequence for Wall-mounted AC Drives	34
<b>6</b>	<b>Electrical Installation</b>	<b>36</b>
6.1	Cable Connections	36
6.1.1	General Cable Requirements	37
6.1.2	UL Standards on Cabling	37
6.1.3	Cable Selection and Dimensioning	37
6.1.4	Cable Selection and Dimensioning, North America	37
6.1.5	Fuse Selection	38
6.2	Grounding	38
6.3	EMC-compliant Installation	39
6.4	Get Access and Locate the Terminals	40
6.4.1	Get Access and Locate the Terminals for FR4/FI4	40
6.4.2	Get Access and Locate the Terminals for FR6/FI6	42
6.4.3	Get Access and Locate the Terminals for FR7/FI7	44
6.4.4	Get Access and Locate the Terminals for FR8/FI8	46
6.5	Installing the Cables	48
6.5.1	Additional Instructions for Cable Installation	49
6.5.2	Installing the Cables, FR4-FR6/FI4-FI6	49
6.5.3	Installing the Cables, FR7/FI7	52
6.5.4	Installing the Cables, FR8/FI8	55
<b>7</b>	<b>Control Unit</b>	<b>59</b>
7.1	Control Unit Components	59
7.2	Control Voltage (+24 V/EXT +24 V)	59
7.3	Control Unit Cabling	60
7.3.1	Selection of the Control Cables	60
7.3.2	Control Terminals on OPTA1	61
7.3.2.1	Digital Input Signal Inversions	62
7.3.2.2	Jumper Selections on the OPTA1 Basic Board	63
7.3.3	Control Terminals on OPTA2 and OPTA3	64
7.4	Installation of Option Boards	66
7.5	Galvanic Isolation Barriers	66
<b>8</b>	<b>Using the Control Panel</b>	<b>68</b>
8.1	Navigating on the Control Panel	68
8.2	Using the Monitoring Menu (M1)	68
8.2.1	Monitored Values	69
8.3	Using the Parameter Menu (M2)	70
8.3.1	Finding the Parameter	70
8.3.2	Selecting Values	71
8.3.3	Editing the Values Digit by Digit	72



8.4	Using the Keypad Control Menu	73
8.4.1	Finding the Keypad Control Menu	73
8.4.2	Keypad Control Parameters M3	74
8.4.3	Changing the Control Mode	74
8.4.4	Changing the Rotation Direction	75
8.4.5	Disabling the Stop Motor Function	75
8.4.6	Special Functions in Keypad Control Menu	76
8.4.6.1	Selecting the Keypad as the Control Mode	76
8.4.6.2	Copying the Frequency Reference Set to the Control Panel	76
8.5	Using the Active Faults Menu (M4)	76
8.5.1	Finding the Active Faults Menu	76
8.5.2	Examining the Fault Time Data Record	77
8.5.3	Fault Time Data Record	77
8.6	Using the Fault History Menu (M5)	78
8.6.1	Fault History Menu (M5)	78
8.6.2	Resetting the Fault History	79
8.7	Using the System Menu (M6)	79
8.7.1	Finding the System Menu	79
8.7.2	System Menu Functions	79
8.7.3	Changing the Language	82
8.7.4	Changing the Application	82
8.7.5	Copy Parameters (S6.3)	83
8.7.5.1	Saving Parameter Sets (Parameter Sets S6.3.1)	83
8.7.5.2	Uploading Parameters to Control Panel (Up To Keypad, S6.3.2)	84
8.7.5.3	Downloading Parameters to Drive (Down From Keypad, S6.3.3)	84
8.7.5.4	Activating or Deactivating the Automatic Parameter Back-up (P6.3.4)	84
8.7.5.5	Comparing the Parameters	85
8.7.6	Security	86
8.7.6.1	Finding the Security Menu	86
8.7.6.2	Passwords	86
8.7.6.3	Setting a Password	86
8.7.6.4	Entering a Password	87
8.7.6.5	Deactivating the Password Function	87
8.7.6.6	Locking a Parameter	87
8.7.6.7	Start-up Wizard (P6.5.3)	88
8.7.6.8	Activating/Deactivating the Start-up Wizard	88
8.7.6.9	Enabling/Disabling the Change of Multimonitoring Items	88
8.7.7	Keypad Settings	89
8.7.7.1	Finding the Keypad Settings Menu	89
8.7.7.2	Changing the Default Page	89
8.7.7.3	Default Page in the Operating Menu (P6.6.2)	90
8.7.7.4	Setting the Timeout Time	90

8.7.7.5	Contrast Adjustment (P6.6.4)	90
8.7.7.6	Backlight Time (P6.6.5)	90
8.7.8	Hardware Settings	90
8.7.8.1	Finding the Hardware Setting Menu	90
8.7.8.2	Setting the Internal Brake Resistor Connection	91
8.7.8.3	Fan Control	91
8.7.8.4	Changing the Fan Control Settings	92
8.7.8.5	HMI Acknowledge Timeout (P6.7.3)	92
8.7.8.6	Changing the HMI Acknowledge Timeout	92
8.7.8.7	Changing the Number of Retries to Receive HMI Acknowledgement (P6.7.4)	93
8.7.8.8	Sine Filter (P6.7.5)	93
8.7.8.9	Pre-charge Mode (P6.7.6)	93
8.7.9	System Info	93
8.7.9.1	Finding the System Info Menu	93
8.7.9.2	Total Counters (S6.8.1)	93
8.7.9.3	Trip Counters (S6.8.2)	94
8.7.9.4	Resetting the Trip Counters	94
8.7.9.5	Software (S6.8.3)	94
8.7.9.6	Applications (S6.8.4)	95
8.7.9.7	Examining the Application Page	95
8.7.9.8	Hardware (S6.8.5)	95
8.7.9.9	Checking the Status of an Option Board	95
8.7.9.10	Debug Menu (S6.8.7)	96
8.8	Using the Expander Board Menu	96
8.8.1	Expander Board Menu	96
8.8.2	Examining the Connected Option Boards	96
8.8.3	Finding the Option Board Parameters	97
8.9	Further Control Panel Functions	97
<b>9</b>	<b>Commissioning</b>	<b>98</b>
9.1	Safety Checks before Starting the Commissioning	98
9.2	Commissioning the Inverter	99
9.3	Measuring the Cable and Motor Insulation	100
9.3.1	Insulation Checks of the Motor Cable	100
9.3.2	Insulation Checks of the DC Supply Cable	101
9.3.3	Insulation Checks of the Motor	101
9.4	Checks after Commissioning	101
9.4.1	Testing the Inverter after Commissioning	101
9.4.2	RUN Test without Load	102
9.4.3	Start-up Test	102
9.4.4	Motor Run Checklist	103

<b>10 Maintenance</b>	<b>104</b>
10.1 Maintenance Schedule	104
10.2 Reforming the Capacitors	104
<b>11 Fault Tracing</b>	<b>106</b>
11.1 General Information on Fault Tracing	106
11.2 Resetting a Fault	106
11.3 Creating Service Info File	107
<b>12 Specifications</b>	<b>108</b>
12.1 Weights of the Inverter	108
12.2 Dimensions	108
12.2.1 Dimensions for FI4–FI8	109
12.2.2 Dimensions for Flange Mounting, FI4–FI6	110
12.2.3 Dimensions for Flange Mounting, FI7–FI8	112
12.3 Cable and Fuse Sizes	114
12.3.1 Fuse Sizes for 465–800 V DC (380–500 V AC)	114
12.3.2 Fuse Sizes for 640–1100 V DC (525–690 V AC)	115
12.3.3 Cable Sizes for 465–800 V DC (380–500 V AC)	115
12.3.4 Cable Sizes for 640–1100 V DC (525–690 V AC)	116
12.4 Cable Stripping Lengths	116
12.5 Tightening Torques for Cover Screws	118
12.6 Tightening Torques of the Terminals	118
12.7 Power Ratings	118
12.7.1 Overload Capability	118
12.7.2 Power Ratings for 465–800 V DC (380–500 V AC)	120
12.7.3 Power Ratings for 640–1100 V DC (525–690 V AC)	120
12.8 Technical Data	121
12.9 DC Currents and DC Link Capacitance	124
12.9.1 DC Currents, Supply Voltage 465–800 V DC	125
12.9.2 DC Currents, Supply Voltage 640–1100 V DC	125
12.9.3 DC Link Capacitance	126
12.10 Faults and Alarms	126

## 1 Introduction

### 1.1 Purpose of this Operating Guide

This operating guide provides information for safe installation and commissioning of the AC drive. It is intended for use by qualified personnel. Read and follow the instructions to use the drive safely and professionally. Pay particular attention to the safety instructions and general warnings. Always keep this operating guide available with the drive.

### 1.2 Additional Resources

Other resources are available to understand advanced AC drive functions and programming.

- The VACON® NX All-in-One Application Manual provides greater detail on working with parameters and shows many application examples.
- The VACON® NX I/O Boards User Manual gives more information on the I/O boards and their installation.
- Instructions for operation with option boards and other optional equipment.

Supplementary publications and manuals are available from Danfoss.

NOTE! Download the English and French product manuals with applicable safety, warning and caution information from <https://www.danfoss.com/en/service-and-support/>.

REMARQUE Vous pouvez télécharger les versions anglaise et française des manuels produit contenant l'ensemble des informations de sécurité, avertissements et mises en garde applicables sur le site <https://www.danfoss.com/en/service-and-support/>.

### 1.3 Disposal

#### Context:

Do not dispose of equipment containing electrical components together with domestic waste. Collect it separately in accordance with local and currently valid legislation.



### 1.4 Type Approvals and Certifications

The following list is a selection of possible type approvals and certifications for Danfoss drives:



			 www.tuv.com ID 060000000		

### NOTICE

The specific approvals and certification for the drive are on the nameplate of the drive. For more information, contact the local Danfoss office or partner.

## 1.5 Start up Quick Guide

### Context:

Do at minimum these procedures during the installation and commissioning.

If there are problems, speak to the local distributor.

VACON Ltd is not responsible for the use of the inverters against the instructions.

### Procedure

1. Check that the delivery agrees to the order, see [4.1 Checking the Delivery](#).
  2. Before starting the commissioning, read carefully the safety instructions in [2.2 Danger and Warnings](#) and [2.3 Cautions and Notices](#).
  3. Before the mechanical installation, check the minimum clearances around the unit ([5.2.2 Cooling of FI4 to FI8](#)) and check the ambient conditions in [12.8 Technical Data](#).
  4. Check the dimensions of the motor cable, DC supply cable, mains fuses, and check the cable connections. Read [6.1 Cable Connections](#), [6.3 EMC-compliant Installation](#), and [6.2 Grounding](#).
  5. Obey the installation instructions, see [6.5 Installing the Cables](#).
  6. Find information on the control connections in [7.3.2 Control Terminals on OPTA1](#).
  7. If the start-up wizard is active, select the language of the control panel and the application. Accept the selections with the Enter button. If the start-up wizard is not active, obey the instructions a and b.
    - A Select the language of the control panel from the Menu M6, page 6.1. For instructions, see [8.7.3 Changing the Language](#).
    - B Select the application from the Menu M6, page 6.2. For instructions, see [8.7.4 Changing the Application](#).
  8. All parameters have factory default values. To make sure that the AC drive operates correctly, make sure that these group G2.1 parameters have the same data as the nameplate. For more information on the parameters in the list, see the VACON® All in One Application Manual.
    - Nominal voltage of the motor
    - Nominal frequency of the motor
    - Nominal speed of the motor
    - Nominal current of the motor
    - Motor cos phi
  9. Obey the commissioning instructions, see [9.2 Commissioning the Inverter](#).
- The VACON® NX Inverter is ready for operation.

## 2 Safety

### 2.1 Safety Symbols

The following symbols are used in this manual:

#### ⚠ DANGER ⚠

Indicates a hazardous situation which, if not avoided, will result in death or serious injury.

#### ⚠ WARNING ⚠

Indicates a hazardous situation which, if not avoided, could result in death or serious injury.

#### ⚠ CAUTION ⚠

Indicates a hazardous situation which, if not avoided, could result in minor or moderate injury.

#### NOTICE

Indicates information considered important, but not hazard-related (for example, messages relating to property damage).

### 2.2 Danger and Warnings

#### ⚠ DANGER ⚠

##### **SHOCK HAZARD FROM INVERTER POWER UNIT COMPONENTS**

The inverter power unit components are live when the inverter is connected to DC supply. A contact with this voltage can lead to death or serious injury.

- Do not touch the components of the power unit when the inverter is connected to DC supply. Before connecting the inverter to DC supply, make sure that the covers of the inverter are closed.

#### ⚠ DANGER ⚠

##### **SHOCK HAZARD FROM INVERTER TERMINALS**

The motor terminals U, V, W, the brake resistor terminals, or the DC terminals are live when the inverter is connected to DC supply, also when the motor does not operate. A contact with this voltage can lead to death or serious injury.

- Do not touch the motor terminals U, V, W, the brake resistor terminals, or the DC terminals when the inverter is connected to DC supply. Before connecting the inverter to DC supply, make sure that the covers of the inverter are closed.

**⚠ DANGER ⚠****SHOCK HAZARD FROM DC LINK OR EXTERNAL SOURCE**

The terminal connections and the components of the drive can be live 5 minutes after the inverter is disconnected from the DC supply and the motor has stopped. Also the load side of the inverter can generate voltage. A contact with this voltage can lead to death or serious injury.

- Before doing electrical work on the inverter:
  - Disconnect the inverter from the DC supply and make sure that the motor has stopped.
  - Lock out and tag out the power source to the inverter.
  - Make sure that no external source generates unintended voltage during work.
  - Wait 5 minutes before opening the cabinet door or the cover of the inverter.
  - Use a measuring device to make sure that there is no voltage.

**⚠ WARNING ⚠****SHOCK HAZARD FROM INVERTER CONTROL TERMINALS**

The control terminals can have a dangerous voltage also when the drive is disconnected from DC supply. A contact with this voltage can lead to injury.

- Make sure that there is no voltage in the control terminals before touching the control terminals.

**⚠ WARNING ⚠****ACCIDENTAL MOTOR START**

When there is a power-up, a power break, or a fault reset, the motor starts immediately if the start signal is active, unless the pulse control for Start/Stop logic is selected. If the parameters, the applications or the software change, the I/O functions (including the start inputs) can change. If you activate the auto reset function, the motor starts automatically after an automatic fault reset. See the Application Guide. Failure to ensure that the motor, system, and any attached equipment are ready for start can result in personal injury or equipment damage.

- Disconnect the motor from the drive if an accidental start can be dangerous. Make sure that the equipment is safe to operate under any condition.

**⚠ WARNING ⚠****LEAKAGE CURRENT HAZARD**

Leakage currents exceed 3.5 mA. Failure to ground the drive properly can result in death or serious injury.

- Ensure the correct grounding of the equipment by a certified electrical installer.

**⚠ WARNING ⚠****SHOCK HAZARD FROM PE CONDUCTOR**

The drive can cause a DC current in the PE conductor. Failure to use a residual current-operated protective (RCD) device Type B or a residual current-operated monitoring (RCM) device can lead to the RCD not providing the intended protection and therefore can result in death or serious injury.

- Use a type B RCD or RCM device on the mains side of the drive.



## 2.3 Cautions and Notices

### ⚠ CAUTION ⚠

#### **DAMAGE TO THE AC DRIVE FROM INCORRECT MEASUREMENTS**

Doing measurements on the AC drive when it is connected to mains can damage the drive.

- Do not do measurements when the AC drive is connected to mains.

### ⚠ CAUTION ⚠

#### **DAMAGE TO THE AC DRIVE FROM INCORRECT SPARE PARTS**

Using spare parts that are not from the manufacturer can damage the drive.

- Do not use spare parts that are not from the manufacturer.

### ⚠ CAUTION ⚠

#### **DAMAGE TO THE AC DRIVE FROM INSUFFICIENT GROUNDING**

Not using a grounding conductor can damage the drive.

- Make sure that the AC drive is always with a grounding conductor that is connected to the grounding terminal that is identified with the PE symbol.

### ⚠ CAUTION ⚠

#### **CUT HAZARD FROM SHARP EDGES**

There can be sharp edges in the AC drive that can cause cuts.

- Wear protective gloves when mounting, cabling, or doing maintenance operations.

### ⚠ CAUTION ⚠

#### **BURN HAZARD FROM HOT SURFACES**

Touching surfaces, which are marked with the 'hot surface' sticker, can result in injury.

- Do not touch surfaces which are marked with the 'hot surface' sticker.

### NOTICE

#### **DAMAGE TO THE AC DRIVE FROM STATIC VOLTAGE**

Some of the electronic components inside the AC drive are sensitive to ESD. Static voltage can damage the components.

- Remember to use ESD protection always when working with electronic components of the AC drive. Do not touch the components on the circuit boards without proper ESD protection.

**NOTICE****DAMAGE TO THE AC DRIVE FROM MOVEMENT**

Movement after installation can damage the drive.

- Do not move the AC drive during operation. Use a fixed installation to prevent damage to the drive.

**NOTICE****DAMAGE TO THE AC DRIVE FROM INCORRECT EMC LEVEL**

The EMC level requirements for the AC drive depend on the installation environment. An incorrect EMC level can damage the drive.

- Before connecting the AC drive to the mains, make sure that the EMC level of the AC drive is correct for the mains.

**NOTICE****RADIO INTERFERENCE**

In a residential environment, this product can cause radio interference.

- Take supplementary mitigation measures.

**NOTICE****MAINS CONNECTION DEVICE**

If the AC drive is used as a part of a machine, the machine manufacturer must supply a mains disconnection device (refer to EN 60204-1).

**NOTICE****MALFUNCTION OF FAULT CURRENT PROTECTIVE SWITCHES**

Because there are high capacitive currents in the AC drive, it is possible that the fault current protective switches do not operate correctly.

**NOTICE****VOLTAGE WITHSTAND TESTS**

Doing voltage withstand tests can damage the drive.

- Do not do voltage withstand tests on the AC drive. The manufacturer has already done the tests.

### 3 Product Overview

#### 3.1 Introduction

The figure presents the block diagram of the VACON® NX inverter. The inverter mechanically consists of 2 units: the Power Unit and the Control Unit.

The Power Unit contains an inverter bridge which consists of IGBT switches and produces a symmetrical, 3-phase PWM-modulated AC voltage to the motor. To protect the DC-link capacitors, the Power Unit also contains a charging circuit for controlled DC-link charge. Use the B+ and DC-terminals to bypass the charging circuit.

The Motor and Application Control Block is based on microprocessor software. The microprocessor controls the motor based on the information it receives through measurements, parameter settings, control I/O, and control panel.

The motor and application control block controls the motor control ASIC which, in turn, calculates the IGBT positions. Gate drivers amplify these signals for driving the IGBT inverter bridge.

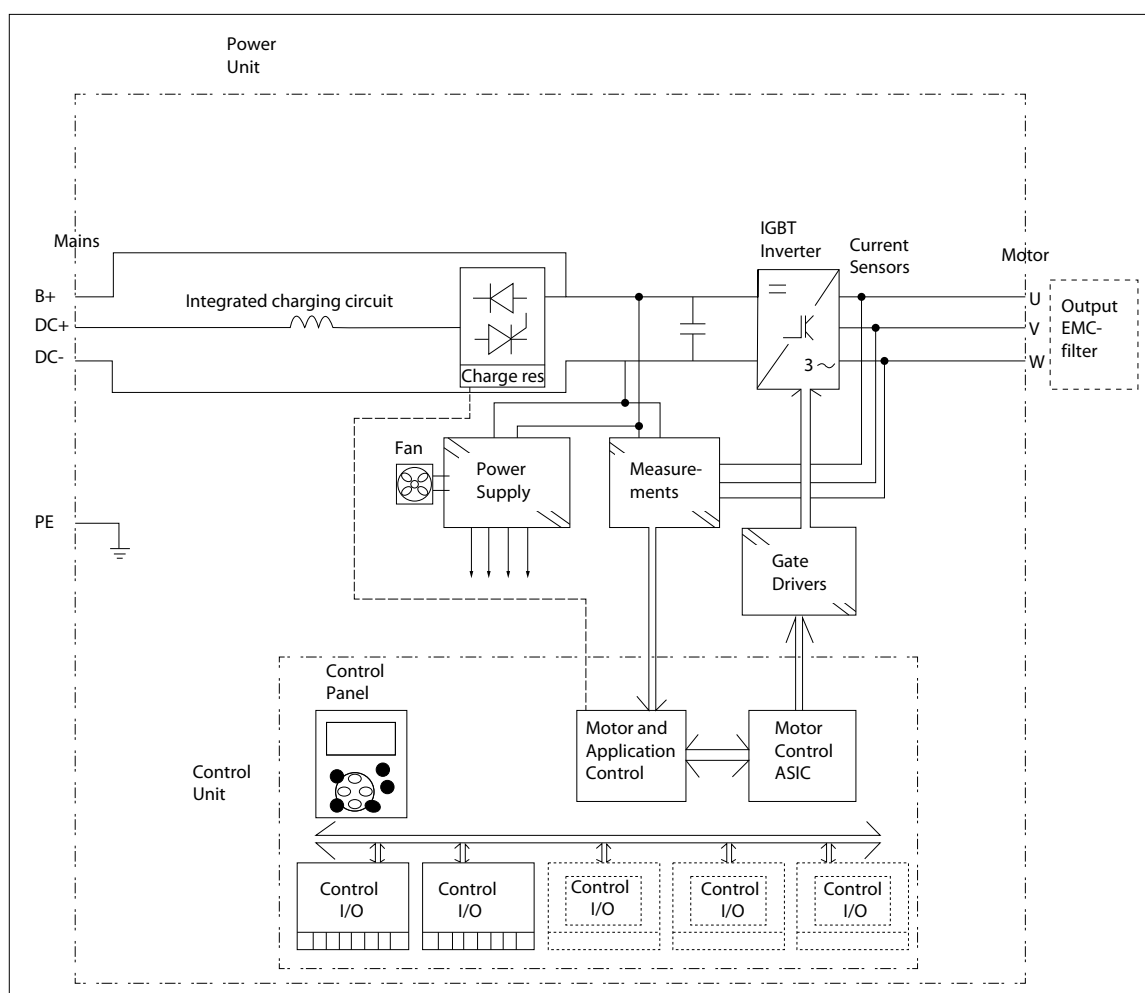

e.30bh433.10

Illustration 1: Block Diagram of VACON® NX Inverter

The control panel constitutes a link between the user and the inverter. The control panel is used for parameter setting, reading status data and giving control commands. It is detachable and can be operated externally and is connected via a cable to the inverter. Instead of the control panel, a PC can be used to control the inverter when connected through a similar cable (VACON® RS232PC –1.5M).

The basic control interface and the parameters (the Basic Application) are easy to use. If a more versatile interface or parameters are required, a more suitable application can be selected from the "All in One" Application Package. See the "All in One" Application Manual for more information on the different applications.

Optional I/O expander boards that increase the number of inputs and outputs to be used are also available. For more information, contact the Manufacturer or your local distributor.

### 3.2 Intended Use

The drive is an electronic motor controller intended for:

- Regulation of motor speed in response to system feedback or to remote commands from external controllers. A power drive system consists of the AC drive, the motor, and equipment driven by the motor.
- System and motor status surveillance.

The drive can also be used for motor overload protection.

Depending on the configuration, the drive can be used in standalone applications or form part of a larger appliance or installation.

The drive is allowed for use in residential, industrial, and commercial environments in accordance with local laws and standards.

#### NOTICE

In a residential environment, this product can cause radio interference, in which case supplementary mitigation measures can be required.

#### Foreseeable misuse

Do not use the drive in applications which are non-compliant with specified operating conditions and environments. Ensure compliance with the conditions specified in [12.8 Technical Data](#).

### 3.3 Manual Version

This manual is regularly reviewed and updated. All suggestions for improvement are welcome.

The original language of this manual is English.

**Table 1: Manual and Software Version**

Edition	Remarks
DPD00908D	Structure of the manual changed.



### 3.4 Standard Features of VACON NX Inverters

Table 2: Standard Features of VACON® NX Inverters FI4-FI8

	INU
Sales code	NXI_AAAA 5/6
Standard features for FI4, FI6, and FI7	DC connection
	IP21
	Air cooling
	Integrated charging
	Alphanumeric control panel (in the front end of the module)
	I/O modules A1 & A2
	Standard board
	Safety CE/UL
Sales code	NXI_AAAA 5/6
Standard features for FI8	DC connection
	IP00
	Air cooling
	Integrated charging
	Alphanumeric control panel (in the front end of the module)
	I/O modules A1 & A2
	Standard board
	Safety CE/UL

### 3.5 Package Label

The package label gives detailed information about the delivery.

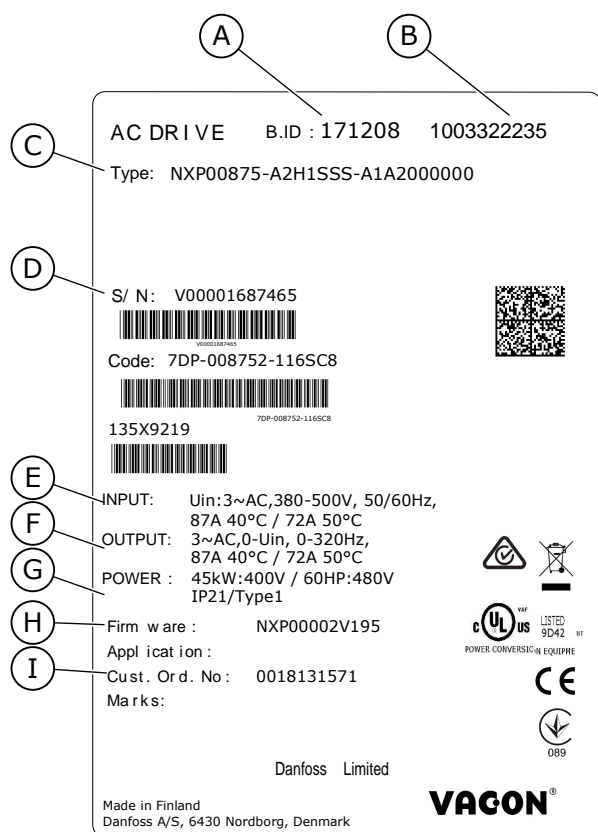

e30bf961.10

A The batch ID	B The order number of VACON®
C The type code	D The serial number
E The mains voltage	F The nominal output current
G The protection rating	H The firmware code
I The order number of the customer	

Illustration 2: Package Label of VACON® NX AC Drives (Example)

### 3.6 Description of the Type Code

The type code of VACON® is made of standard codes and optional codes. Each part of the type code agrees to the data in the order.

**Example:**

The code can have this format, for example:

- NXI00035-A2T0SSS-A1A2C30000+DN0T

Table 3: Description of the Type Code

Code	Description
VACON	This part is same for all the products.

Code	Description
NXI	The product range: <ul style="list-style-type: none"> <li>NXI = VACON® NX Inverter</li> </ul>
0003	The drive rating in amperes. For example, 0003 = 3 A
5	The mains voltage: <ul style="list-style-type: none"> <li>5 = 380–500 V</li> <li>6 = 525–690 V (IEC)</li> </ul>
A	The control panel: <ul style="list-style-type: none"> <li>A = standard (text display)</li> <li>B = no local control panel</li> <li>F = dummy keypad</li> <li>G = graphical display</li> </ul>
2	The protection rating: <ul style="list-style-type: none"> <li>0 = IP00</li> <li>2 = IP21 (UL Type 1)</li> <li>5 = IP54 (UL Type 12)</li> </ul>
T	The EMC emission level: <ul style="list-style-type: none"> <li>T = complies with the standard IEC/EN 61800-3 + A1 when used in IT networks (C4).</li> </ul>
0	The brake chopper: <sup>(1)</sup> <ul style="list-style-type: none"> <li>0 = No brake chopper</li> </ul>
SSS	The hardware changes: <ul style="list-style-type: none"> <li>The supply, the first letter (Xxx): <ul style="list-style-type: none"> <li>C = INU - with integrated charging circuit</li> <li>I = INU - no charging circuit</li> <li>2 = AFE module</li> <li>5 = AFE module + LCL filter</li> <li>8 = BCU brake chopper unit</li> </ul> </li> <li>The mounting, the second letter: (xxX): <ul style="list-style-type: none"> <li>S = Standard air cooled drive</li> <li>U = Standard air cooled power unit - external supply for main fan</li> </ul> </li> <li>The boards, the third letter (xxX): <ul style="list-style-type: none"> <li>S = Direct connection, standard boards, FI4-FI8</li> <li>V = Direct connection, varnished boards, FI4-FI8</li> <li>F = Fiber connection, standard boards</li> <li>G = Fiber connection, varnished boards</li> </ul> </li> </ul>

Code	Description
A1A2C30000	<p>The option boards. 2 characters for each slot. 00 = the slot is not used</p> <p>The option board abbreviations:</p> <ul style="list-style-type: none"> <li>• A = basic I/O board</li> <li>• B = expander I/O board</li> <li>• C = fieldbus board</li> <li>• D = special board</li> </ul> <p>For example, C3 = PROFIBUS DP</p>
+DNOT	<p>The optional codes. There are many options.</p> <p>The options that are related to ordering of paper manuals are:</p> <ul style="list-style-type: none"> <li>• +DNOT = No paper manuals, only Quick Guide and Safety Guide</li> <li>• +DPAP = With English paper manuals</li> <li>• +DPAP+DLDE = With German paper manuals</li> </ul>

<sup>1</sup> Not used for NX Inverters.

### 3.7 Enclosure Sizes

**Example:**

The codes for nominal current and nominal mains voltage are part of the type code (see [3.6 Description of the Type Code](#)) on the package label (see [3.5 Package Label](#)). Use these values to find out the enclosure size of the AC drive from the table.

In the example "NXI00035-A2H1SSS-A1A2C30000+DNOT", the code for nominal current is 0003 and the code for nominal mains voltage is 5.



Table 4: Enclosure Sizes

Nominal mains voltage	Nominal current	Enclosure size
5 (465–800 V DC, 380–500 V AC)	0004	F14
	0009	
	0012	
	0016	F16
	0022	
	0031	
	0038	
	0045	
	0061	F17
	0072	
	0087	
	0105	
	0140	F18
	6 (640–1100 V DC, 525–690 V AC)	0004
0005		
0007		
0010		
0013		
0018		
0022		
0027		
0034		
0041		F17
0052		
0062		F18
0080		
0100		

### 3.8 Available Protection Ratings

Table 5: Available Protection Ratings

Mains voltage	Enclosure size	IP21 (UL Type 1)	IP00
350–500 V	F14-F17	x	
350–500 V	F18		x

Mains voltage	Enclosure size	IP21 (UL Type 1)	IP00
525–690 V	FI4-FI7	x	x
525–690 V	FI8		x

### 3.9 Available EMC Classes

The EMC Directive provides that the electrical apparatus must not excessively disturb the environment it is used in. It also requires that the electrical apparatus must have an adequate level of immunity toward other disturbances from the same environment.

The compliance of VACON® NX Inverters with the EMC Directive is verified with Technical Construction Files (TCF) and checked and approved by SGS FIMKO, which is a Notified Body. The Technical Construction Files are used to authenticate the conformity of VACON® NX Inverters with the Directive. It is because testing such a large product family in a laboratory environment is impossible. Testing is difficult also because the combinations of installation vary greatly.

All factory-delivered VACON® NX Inverters are Class T (Category C4) equipment which fulfills EMC immunity requirements EN 50082-1, 50082-2 and IEC/EN 61800-3.

Class T (Category C4):

Class T equipment have a small ground leakage current and can be used with floating DC input. If they are used with other supplies, no EMC requirements are complied with.

## NOTICE

### RADIO INTERFERENCE

In a residential environment, this product can cause radio interference.

- Take supplementary mitigation measures.

### 3.10 Control Panel

#### 3.10.1 Keypad

The VACON® keypad has 9 buttons with which to control the AC drive (and motor), set parameters, and monitor values.

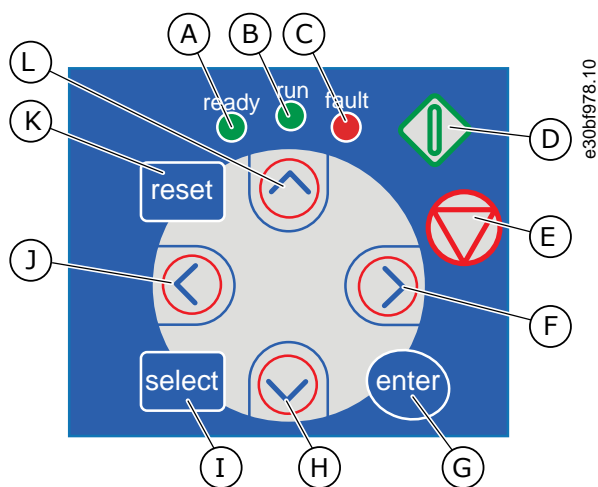

<p><b>A</b> The [ready] LED is on when the AC power is connected to the drive and no faults are active. At the same time, the drive status indication shows <i>READY</i>.</p>	<p><b>B</b> The [run] LED is on when the drive operates. The LED blinks when the Stop button is pushed and the drive ramps down.</p>
<p><b>C</b> The [fault] LED blinks when the AC drive is stopped because of dangerous conditions (Fault Trip). See <a href="#">8.5.1 Finding the Active Faults Menu</a>.</p>	<p><b>D</b> The Start button. When the keypad is the active control mode, this button starts the motor. See <a href="#">8.4.3 Changing the Control Mode</a>.</p>
<p><b>E</b> The Stop button. The button stops the motor (unless the stop is disabled by the parameter R3.4/R3.6). See <a href="#">8.4.2 Keypad Control Parameters M3</a>.</p>	<p><b>F</b> The Menu button Right. Use it to move forward in the menu, move the cursor right (in the parameter menu) and to go to the edit mode.</p>
<p><b>G</b> The [enter] button. Use it to accept a selection, reset the fault history (push for 2–3 s).</p>	<p><b>H</b> The Browser button Down. Use it to scroll the main menu and the pages of different submenus and to decrease a value.</p>
<p><b>I</b> The [select] button. Use it to move between 2 last displays, for example, to see how new value changes some other value.</p>	<p><b>J</b> The Menu button Left. Use it to move back in the menu, move the cursor left (in the Parameter menu).</p>
<p><b>K</b> The [reset] button. Use it to reset a fault.</p>	<p><b>L</b> The Browser button Up. Use it to scroll the main menu and the pages of different submenus and to increase a value.</p>

Illustration 3: Keypad Buttons for VACON® NXP

### 3.10.2 Display

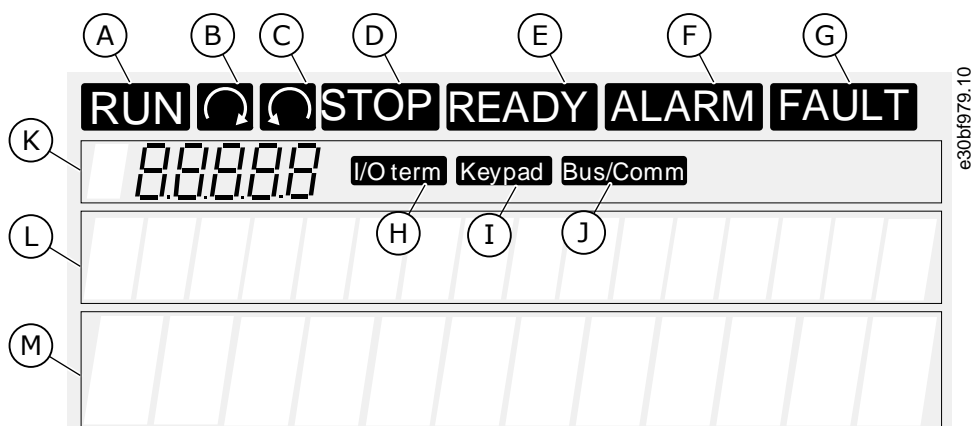

<b>A</b> The motor is in RUN state. The indication starts to blink when a stop command is given and blinks while the speed continues to decrease.	<b>B</b> The motor rotation direction is forward.
<b>C</b> The motor rotation direction is reverse.	<b>D</b> The drive does not operate.
<b>E</b> The AC power is on.	<b>F</b> An alarm is given.
<b>G</b> A fault is given and the AC drive is stopped.	<b>H</b> The I/O terminals is the active control mode.
<b>I</b> The control panel is the active control mode.	<b>J</b> The fieldbus is the active control mode.
<b>K</b> The location indication. The line shows the symbol and number of the menu, parameter and so on. For example, M2 = Menu 2 (Parameters) or P2.1.3 = Acceleration time.	<b>L</b> The description line. The line shows the description of the menu, value, or fault.
<b>M</b> The value line. The line shows the numerical and text values of references, parameters and so on. It also shows the number of submenus that are available in each menu.	

**Illustration 4: Display Indications**

The drive status indicators (A-G) give information about the status of the motor and the AC drive.

The control mode indications (H, I, J) show the selection of the control mode. The control mode tells from where the START/STOP commands are given and reference values are changed. To make this selection, go to the Keypad control menu (M3) (see [8.4.3 Changing the Control Mode](#)).

The three text lines (K, L, M) give information about the current location in the menu structure and the operation of the drive.

### 3.10.3 Basic Menu Structure

The data of the AC drive is in menus and submenus. The figure shows the basic menu structure of the AC drive.

This menu structure is only an example and the contents and items can vary depending on the application in use.

e30bf981.10

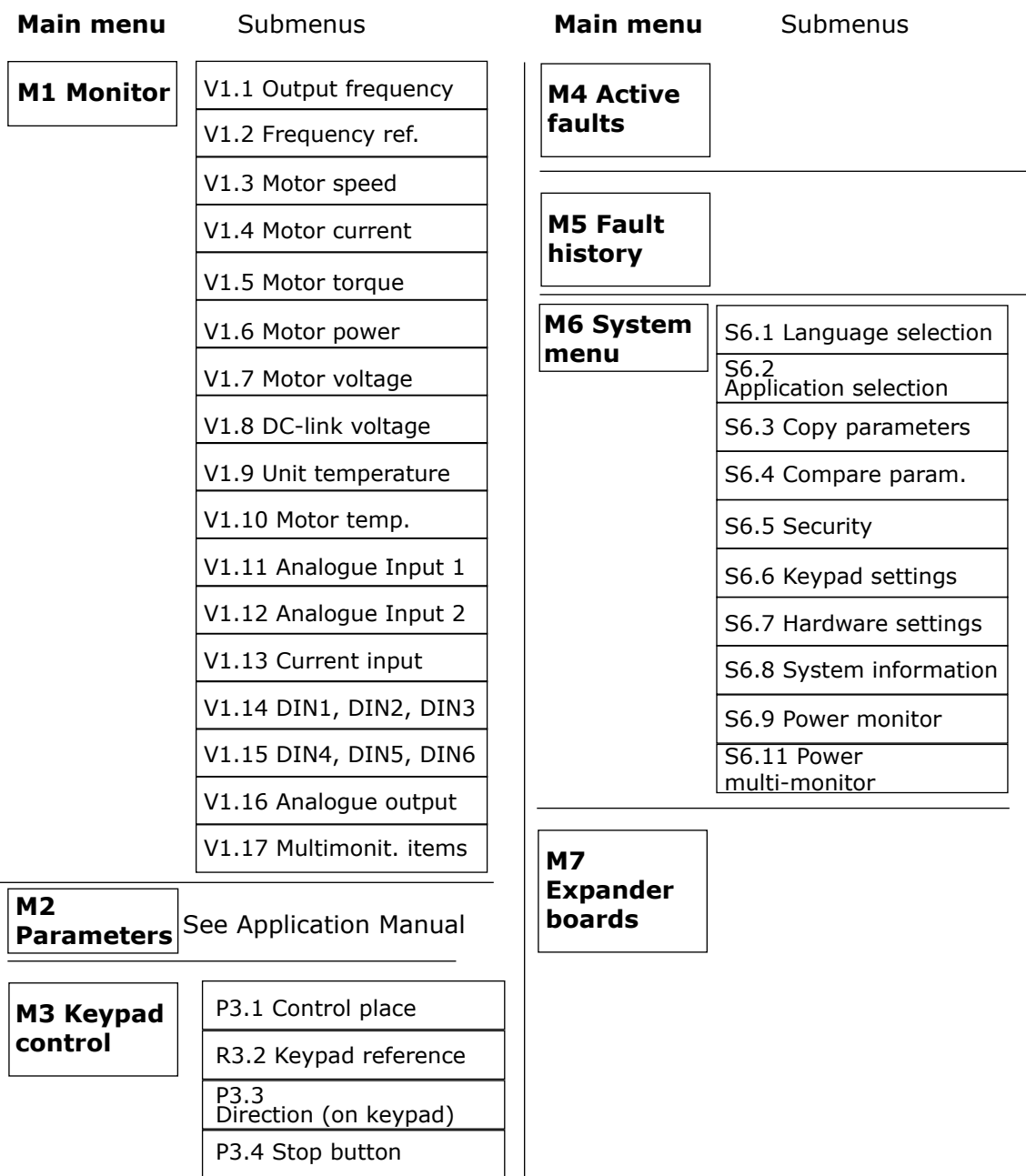

Illustration 5: Basic Menu Structure of the AC Drive

## 4 Receiving the Delivery

### 4.1 Checking the Delivery

#### Context:

Before a VACON® AC drive is sent to the customer, the manufacturer makes many tests on the drive.

**Procedure**

1. After removing the packaging, examine the drive for transport damages.

If the drive was damaged during the shipping, speak to the cargo insurance company or the carrier.

2. To make sure that the delivery is correct, compare the order data to the data on the package label, see [3.5 Package Label](#).

If the delivery does not agree with the order, contact the vendor immediately.

3. To make sure that the contents of the delivery is correct and complete, compare the type code of the product to the type code, see [3.6 Description of the Type Code](#).

4. Check that the accessories bag contains the items shown in the figure. These accessories are part of the electrical installation. The contents of the accessories bag is different for different enclosure sizes and protection ratings.

FR4-FR6/FI4-FI6

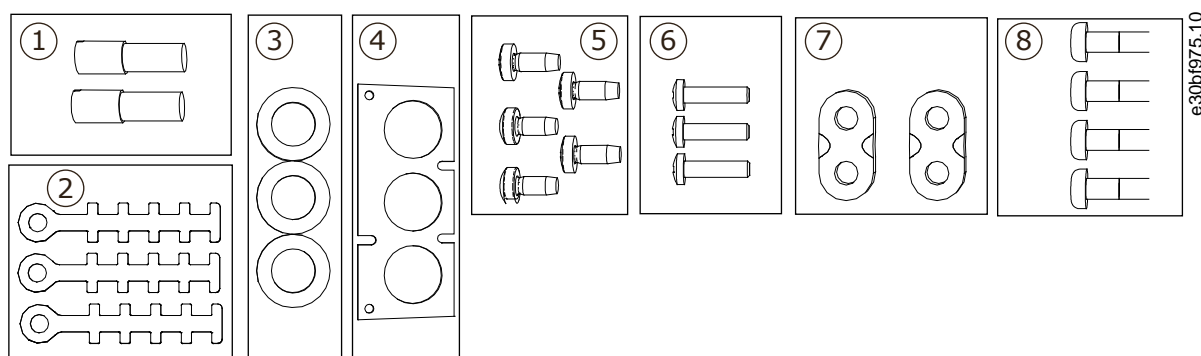

1 The grounding terminals (FR4/FI4, FR5), 2 pieces	2 The grounding clamps for control cable, 3 pieces
3 The rubber grommets (sizes vary from class to class), 3 pieces	4 The cable entry plate
5 Screws, M4x10, 5 pieces	6 Screws, M4x16, 3 pieces
7 The grounding clamps for grounding conductor (FR6/FI6), 2 pieces	8 The grounding screws M5x16 (FR6/FI6), 4 pieces

Illustration 6: Contents of the Accessories Bag for FR4-FR6/FI4-FI6

FR7-FR8/FI7-FI8

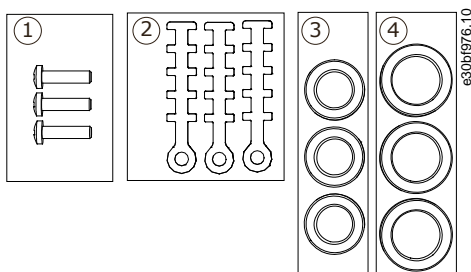

1 Screws, M4x16, 3 pieces	2 The grounding clamps for control cable, 3 pieces
	4 The rubber grommets GDM36 (FR7/FI7), 3 pieces

- 3 The rubber grommets GD21 (FR7/FI7 IP54/UL Type 12), 3 pieces / (FR8/FI8), 6 pieces

Illustration 7: Contents of the Accessories Bag for FR7-FR8/FI7-FI8

## 4.2 Storing the Product

### Context:

If the product has to be stored before installing it, follow these instructions.

#### Procedure

1. If the AC drive must be stored before using it, make sure that the ambient conditions agree to the following:
  - Storage temperature: -40...+70° C (-40...+158° F)
  - Relative humidity: 0–95%, no condensation
2. If the AC drive must be kept in storage for a long time, connect the power to the AC drive each year. Keep the power on for a minimum of 2 hours.
3. If the storage time is more than 12 months, charge the electrolytic DC capacitors with caution. To reform the capacitors, obey the instructions in [10.2 Reforming the Capacitors](#).

We do not recommend a long storage time.

## 4.3 Lifting the Product

### Context:

To get information on how to lift the AC drive safely, speak to the factory or the local distributor.

### Prerequisites:

The weights of AC drives of different enclosure sizes are different. It can be necessary to use a lifting device to move the drive from its package.

#### Procedure

1. Check the weight of the inverter, see [12.1 Weights of the Inverter](#).
2. To lift the AC drives larger than FR7/FI7 out of the package, use a jib crane.
3. After lifting the drive, check for signs of damage on the drive.

## 4.4 Using the Product Modified Label

### Context:

In the accessories bag, there is also a "product modified" label. The function of the label is to tell the service personnel about the changes that are made in the AC drive.



Drive modified:	
<input type="checkbox"/> Option board: NXOPT.....	Date:.....
in slot: A B C D E	Date:.....
<input type="checkbox"/> IP54 upgrade/Collar	Date:.....
<input type="checkbox"/> EMC level modified: H/L to T	Date:.....

e30bf977.10

Illustration 8: The Product Modified Label

**Procedure**

1. Attach the label on the side of the AC drive to know where to find it.
2. If changes are made in the AC drive, write the change on the label.

## 5 Mounting the Unit

### 5.1 Environmental Requirements

#### 5.1.1 General Environmental Requirements

In environments with airborne liquids, particles, or corrosive gases, ensure that the protection rating of the equipment matches the installation environment. Failure to meet requirements for ambient conditions can reduce the lifetime of the AC drive. Ensure that requirements for humidity, temperature, and altitude are met.

#### Vibration and shock

The AC drive complies with requirements for units mounted on the walls and floors of production premises, and in panels bolted to walls or floors.

For detailed ambient conditions specifications, see [12.8 Technical Data](#).

#### Installation requirements:

- Make sure that there is sufficiently free space around the AC drive for cooling, see [5.2.2 Cooling of FI4 to FI8](#).
- Some free space is also necessary for maintenance.
- Make sure that the mounting surface is sufficiently flat.

#### 5.1.2 Ambient Temperature and Derating

The power rating of the unit is valid for an ambient temperature of 40 °C (104 °F). If the device is to be used in higher ambient temperatures, its power rating must be subjected to derating.

Use the following formula to calculate the reduced power:

$$P_{de} = P_n * ((100\% - (t - 40\text{ °C}) * x) / 100)$$

$P_n$  = nominal power of the unit

$t$  = ambient temperature

$x$  = derating coefficient, see the following list:

- in ambient temperature of 40–50 °C, use derating factor 1.5%/1 °C
- For higher temperatures, contact the factory.

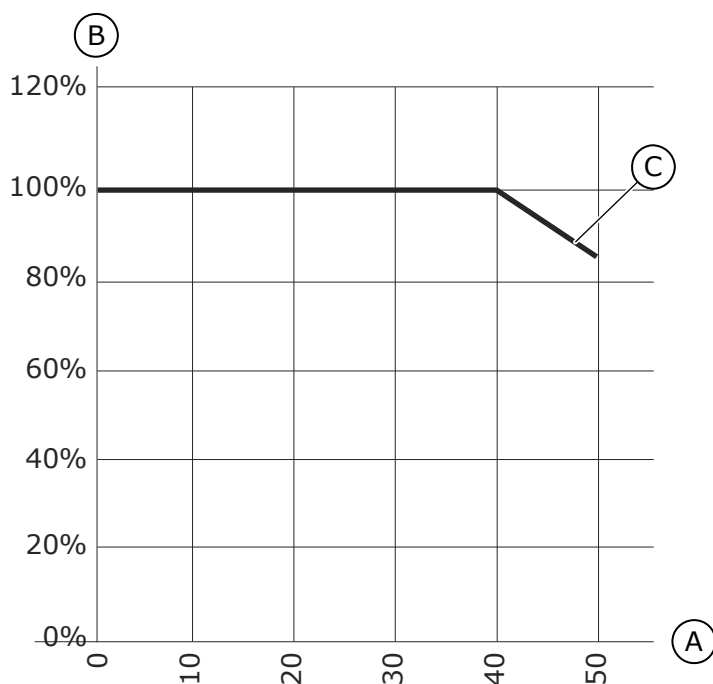

e30bh393.10

A Ambient temperature, °C	B Loadability, %
C Loadability %	

Illustration 9: Derating and the Ambient Temperature

### 5.1.3 High Altitude Installation

The density of air decreases when the altitude increases and the pressure decreases. When the air density decreases, the thermal capacity decreases (that is, less air removes less heat) and the resistance to electric field (breakdown voltage/distance) decreases.

The full thermal performance of VACON® NX AC drives is designed for installation up to 1000 m altitude. The electric insulation is designed for installations up to 3000 m altitude (check details for different sizes in Technical Data).

Higher installation locations are possible, when obeying the derating guidelines in this chapter.

For permitted maximum altitudes, see [12.8 Technical Data](#).

Above 1000 m, decrease the limited maximum load current by 1% for each 100 m.

For information on option boards and I/O signals and relay outputs, see VACON® NX I/O Boards User Manual.

**Example:**

For example, at 2500 m altitude, decrease the load current down to 85% of the rated output current (100% – (2500–1000 m) / 100 m x 1% = 85%).

When using fuses at high altitudes, the cooling effect of the fuse decreases as the density of the atmosphere decreases.

When using fuses above 2000 meters, the continuous rating of the fuse:

$$I = I_n * (1 - (h - 2000) / 100 * 0.5 / 100)$$

Where

I = Current rating at high altitude

$I_n$  = Rated current of a fuse

h = Altitude in meters

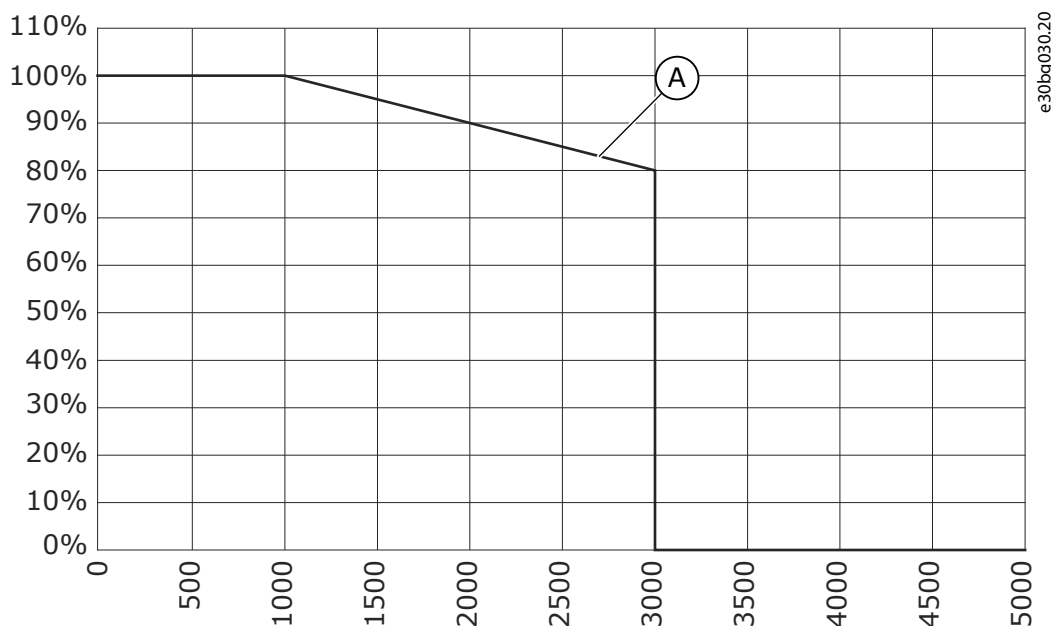

A Loadability

Illustration 10: Loadability in High Altitudes

## 5.2 Cooling Requirements

### 5.2.1 General Cooling Requirements

The AC drive produces heat in operation. The fan moves air and decreases the temperature of the drive. Make sure that there is sufficiently free space around the drive.

Make sure that the temperature of the cooling air does not go above the maximum ambient operating temperature or below the minimum ambient operating temperature of the drive.

### 5.2.2 Cooling of FI4 to FI8

If many AC drives are installed above each other, the necessary free space is C + D (see [illustration 11](#)). Make also sure that the outlet air from the lower drive goes to a different direction than the air intake of the top drive.

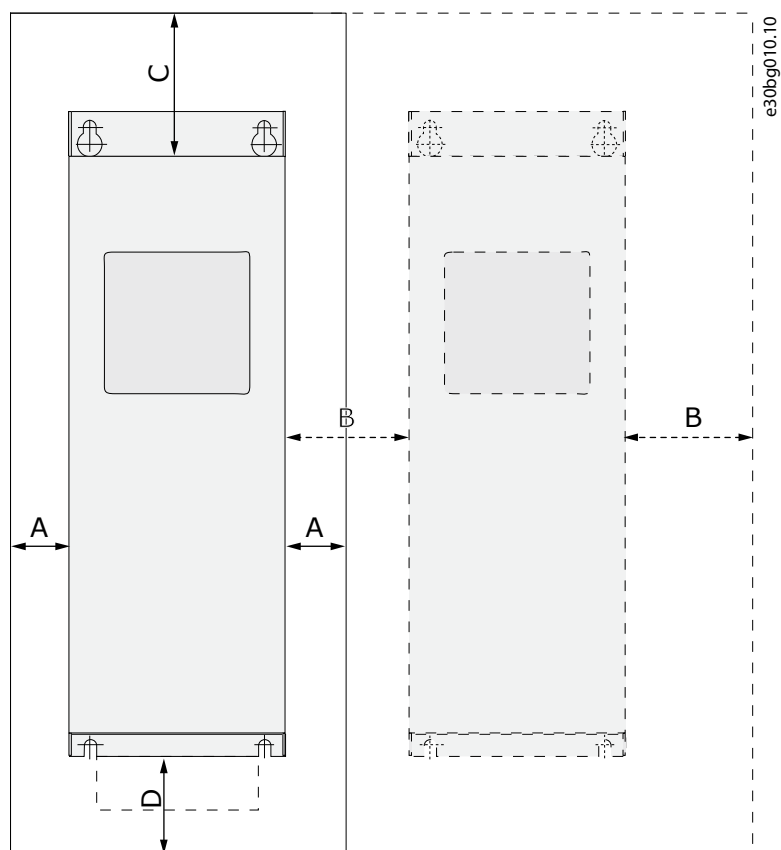

<b>A</b> The clearance around the drive (see also B and C)	<b>B</b> The distance from a drive to a second drive, or the distance to the cabinet wall
<b>C</b> The free space above the drive	<b>D</b> The free space below the drive

Illustration 11: Installation Space

Table 6: Minimum Clearances around the AC Drive in mm (in inch)

Drive type	A	B	C	D
0004 5-0012 5	20 (0.79)	20 (0.79)	100 (3.94)	50 (1.97)
0016 5-0048 5	30 (1.18)	20 (0.79)	160 (6.30)	80 (3.15)
0004 6-0034 6	80 (3.15)	80 (3.15)	300 (11.81)	100 (3.94)

Drive type	A	B	C	D
0140 5	80	80	300	200
0062 6-0100 6	(3.15) <i>(1)</i>	(3.15)	(11.81)	(7.87)

<sup>1</sup> To change the fan with the motor cables connected, the necessary clearance on the 2 sides of the drive is 150 mm (5.91 inch).

**Table 7: Necessary Quantity of Cooling Air**

Drive type	Greatest possible heat loss (kW)	The quantity of cooling air [m <sup>3</sup> /h]	The quantity of cooling air [CFM]
0004 5-0012 5	0.2	70	41.2
0016 5-0048 5	1	425	250
0004 6-0034 6	0.75		
0061 5-0105 5	1.9	425	250
0041 6-0052 6	1.2		
0140 5	3.3	650	383
0062 6-0100 6	2.25		

### 5.3 Installation Sequence for Wall-mounted AC Drives

**Context:**

Use these instructions to install the VACON® NX Wall-mounted AC Drive or VACON® NX Inverter FI4-FI8.

**Prerequisites:**

If the inverter is installed outside the enclosure, cabinet or device space, install a separate inverter cover in accordance with protection class IP21 requirements. There is no need to install the inverter cover if the inverter is installed in an enclosure, separate cabinet, or device space.

**Procedure**

1. Select the mounting option:

- Horizontal

If the drive is installed in a horizontal position, there is no protection against drops of water that fall vertically.

- Vertical

- Flange mounting

The AC drive can also be installed into the cabinet wall with a flange mounting option (throughhole mounting). With the flange mounting, the protection rating of the power unit is IP54 (UL Type 12) and the protection rating of the control unit is IP21 (UL Type 1).

2. Check the dimensions of the AC drive, see [12.2.1 Dimensions for F14–F18](#), and [12.2.2 Dimensions for Flange Mounting, F14–F16](#) [12.2.3 Dimensions for Flange Mounting, F17–F18](#).
3. Make sure that there is sufficiently free space around the AC drive for cooling, see [5.2.2 Cooling of F14 to F18](#). Some free space is also necessary for maintenance.
4. Attach the AC drive with the screws and other components in the delivery.

## 6 Electrical Installation

### 6.1 Cable Connections

The power cables are connected to terminals **DC+** and **DC-** (R+/B+ and DC terminals when using an external charging circuit) and the motor cables to terminals **U**, **V**, and **W**.

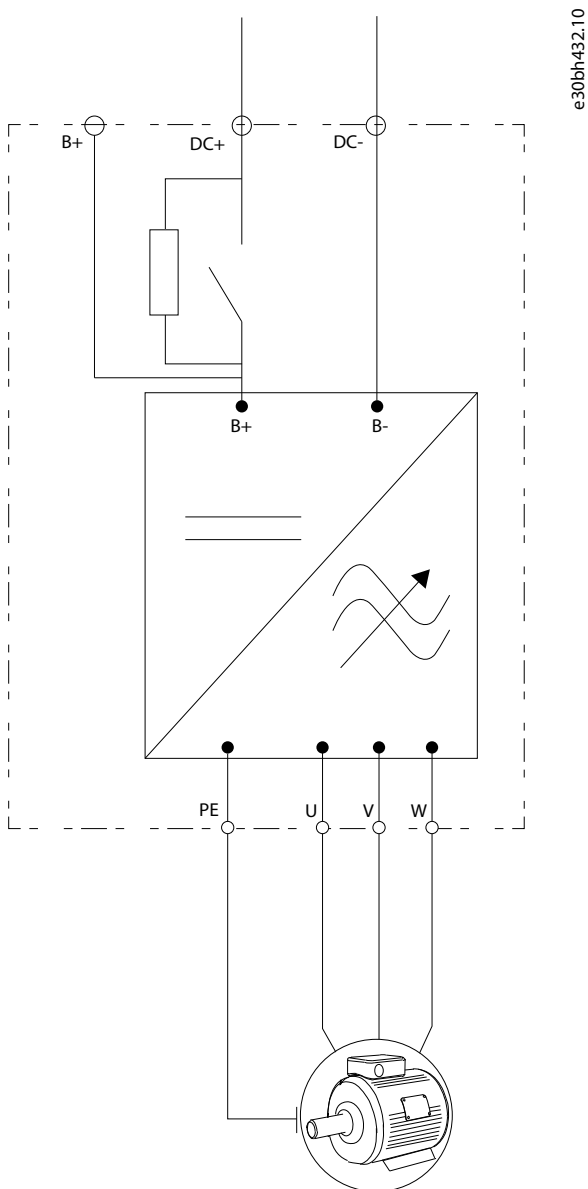

Illustration 12: Principal Connection Diagram

For EMC-compliant installation, see [6.3 EMC-compliant Installation](#).



### 6.1.1 General Cable Requirements

Use cables with a minimum heat resistance of +60 °C (140 °F). In the selection of the cables and the fuses, refer to the nominal output current of the drive. Find the nominal output current on the nameplate.

For information on how to make the cable installation to comply with the UL standards, see [6.1.2 UL Standards on Cabling](#).

If the motor temperature protection of the drive (see VACON® All in One Application Manual) is used as an overload protection, select the cable to agree with the protection. If 3 or more cables are used in parallel for larger AC drives, use a separate overload protection for each cable.

These instructions are valid only for processes that have 1 motor and 1 cable connection from the AC drive to the motor. In other conditions, speak to the manufacturer to get more information.

### 6.1.2 UL Standards on Cabling

To comply with the UL (Underwriters Laboratories) regulations, use a UL-approved copper wire with a minimum heat resistance of 60 °C or 75 °C (140 °F or 167 °F).

Use Class 1 wire only.

The integral solid-state short-circuit protection does not give a branch circuit protection. To get the branch circuit protection, obey the National Electric Code and any additional local codes. Only fuses give the branch circuit protection.

For the tightening torques of the terminals, see [12.6 Tightening Torques of the Terminals](#).

### 6.1.3 Cable Selection and Dimensioning

Find the typical sizes and types of cables used with the inverter in the tables in [12.3 Cable and Fuse Sizes](#). In the selection of cables, refer to local regulations, cable installation conditions, and cable specification.

**The dimensions of the cables must comply with the requirements of the standard IEC60364-5-52.**

- The cables must be PVC-isolated.
- The maximum ambient temperature is +30 °C.
- The maximum temperature of the cable surface is +70 °C.
- Use only cables with a concentric copper shield.
- The maximum number of parallel cables is 9.

When using parallel cables, make sure to obey the requirements of the cross-sectional area and the maximum number of cables.

For important information on the requirements of the grounding conductor, see [6.2 Grounding](#).

For the correction factors for each temperature, see the standard IEC60364-5-52.

### 6.1.4 Cable Selection and Dimensioning, North America

Find the typical sizes and types of cables used with the AC drive in the tables in [12.3 Cable and Fuse Sizes](#). In the selection of cables, refer to local regulations, cable installation conditions, and cable specification.

**The dimensions of the cables must comply with the requirements of the National Electric Code (NEC) and the Canadian Electric Code (CEC).**

- The cables must be PVC-isolated.
- The maximum ambient temperature is +86 °F.
- The maximum temperature of the cable surface is +158 °F.
- Use only cables with a concentric copper shield.
- The maximum number of parallel cables is 9.

When using parallel cables, make sure to obey the requirements of the cross-sectional area and the maximum number of cables.

For important information on the requirements of the grounding conductor, see the NEC and CEC.

For the correction factors for each temperature, see the instructions of NEC and CEC.

### 6.1.5 Fuse Selection

Find the recommended fuses in tables in [12.3 Cable and Fuse Sizes](#).

Information about the fuses:

- aR fuses protect the cables of the device against short circuits.
- gR fuses are designed to protect the device against both overcurrent and short circuits.
- gG fuses are used to protect cables against overcurrent and short circuits.

## 6.2 Grounding

Ground the AC drive in accordance with applicable standards and directives.

### ⚠ CAUTION ⚠

#### DAMAGE TO THE AC DRIVE FROM INSUFFICIENT GROUNDING

Not using a grounding conductor can damage the drive.

- Make sure that the AC drive is always with a grounding conductor that is connected to the grounding terminal that is identified with the PE symbol.

### ⚠ WARNING ⚠

#### LEAKAGE CURRENT HAZARD

Leakage currents exceed 3.5 mA. Failure to ground the drive properly can result in death or serious injury.

- Ensure the correct grounding of the equipment by a certified electrical installer.

The standard EN 61800-5-1 tells that 1 or more of these conditions for the protective circuit must be true.

**The connection must be fixed.**

- The protective earthing conductor must have a cross-sectional area of minimum 10 mm<sup>2</sup> Cu or 16 mm<sup>2</sup> Al. OR
- There must be an automatic disconnection of the mains, if the protective earthing conductor breaks. OR
- There must be a terminal for a second protective earthing conductor in the same cross-sectional area as the first protective earthing conductor.

Cross-sectional area of the phase conductors (S) [mm <sup>2</sup> ]	The minimum cross-sectional area of the protective earthing conductor in question [mm <sup>2</sup> ]
$S \leq 16$	S
$16 < S \leq 35$	16
$35 < S$	S/2

The values of the table are valid only if the protective earthing conductor is made of the same metal as the phase conductors. If this is not so, the cross-sectional area of the protective earthing conductor must be determined in a manner that produces a conductance equivalent to that which results from the application of this table.

The cross-sectional area of each protective earthing conductor that is not a part of the mains cable or the cable enclosure, must be a minimum of:

- 2.5 mm<sup>2</sup> if there is mechanical protection, and
- 4 mm<sup>2</sup> if there is not mechanical protection. With cord-connected equipment, make sure that the protective earthing conductor in the cord is the last conductor to be interrupted, if the strain-relief mechanism breaks.

Obey the local regulations on the minimum size of the protective earthing conductor.

### NOTICE

#### **MALFUNCTION OF FAULT CURRENT PROTECTIVE SWITCHES**

Because there are high capacitive currents in the AC drive, it is possible that the fault current protective switches do not operate correctly.

### NOTICE

#### **VOLTAGE WITHSTAND TESTS**

Doing voltage withstand tests can damage the drive.

- Do not do voltage withstand tests on the AC drive. The manufacturer has already done the tests.

### ⚠ WARNING ⚠

#### **SHOCK HAZARD FROM PE CONDUCTOR**

The drive can cause a DC current in the PE conductor. Failure to use a residual current-operated protective (RCD) device Type B or a residual current-operated monitoring (RCM) device can lead to the RCD not providing the intended protection and therefore can result in death or serious injury.

- Use a type B RCD or RCM device on the mains side of the drive.

## 6.3 EMC-compliant Installation

To comply with the EMC levels, use a grommet when installing the motor cable at the two ends. For the EMC level C4, it is necessary to have a 360° grounding of the shield with grommets in the motor end.

Table 8: Recommendations for Cables

Cable type	Category C4 (Level T)
Supply cable	Power cable intended for fixed installation and the specific DC voltage. Shielded cable not required. (NKCABLES/MCMK or similar recommended)
Motor cable	Power cable equipped with concentric protection wire and intended for the specific mains voltage. (NKCABLES/MCMK or similar recommended).
Control cable	Shielded cable equipped with compact low-impedance shield (NKCABLES/jamak, SAB/ÖZCuY-O or similar).

For the definitions of EMC protection levels, see IEC/EN 61800-3 + A1.

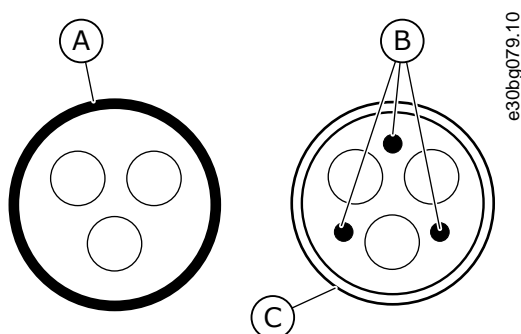

A The PE conductor and the shield	B The PE conductors
C The shield	

Illustration 13: Cables with PE Conductors

In all the enclosure sizes, to comply with the EMC standards, use the default values of the switching frequencies.

If installing a safety switch, make sure that the EMC protection continues from the start of the cables until their ends.

The drive must obey the standard IEC 61000-3-12. To obey it, the short circuit power  $S_{SC}$  must be a minimum of  $120 R_{SCE}$  at the interface point between mains and the public mains. Make sure to connect the drive and the motor to mains with a short circuit power  $S_{SC}$  that is a minimum of  $120 R_{SCE}$ . If necessary, contact the mains operator.

## 6.4 Get Access and Locate the Terminals

### 6.4.1 Get Access and Locate the Terminals for FR4/FI4

#### Context:

Follow these instructions to open the AC drive for installing the cables, for example.

**Procedure**

1. Open the cover of the AC drive.

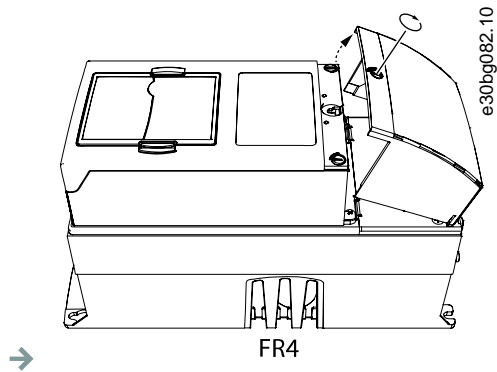

2. Remove the screws of the cable cover. Remove the cable cover. Do not open the cover of the power unit.

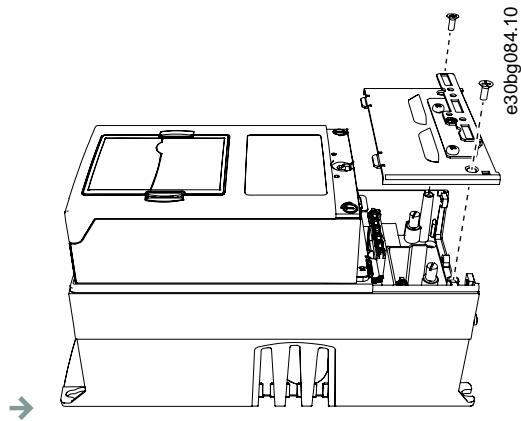

3. Locate the terminals.

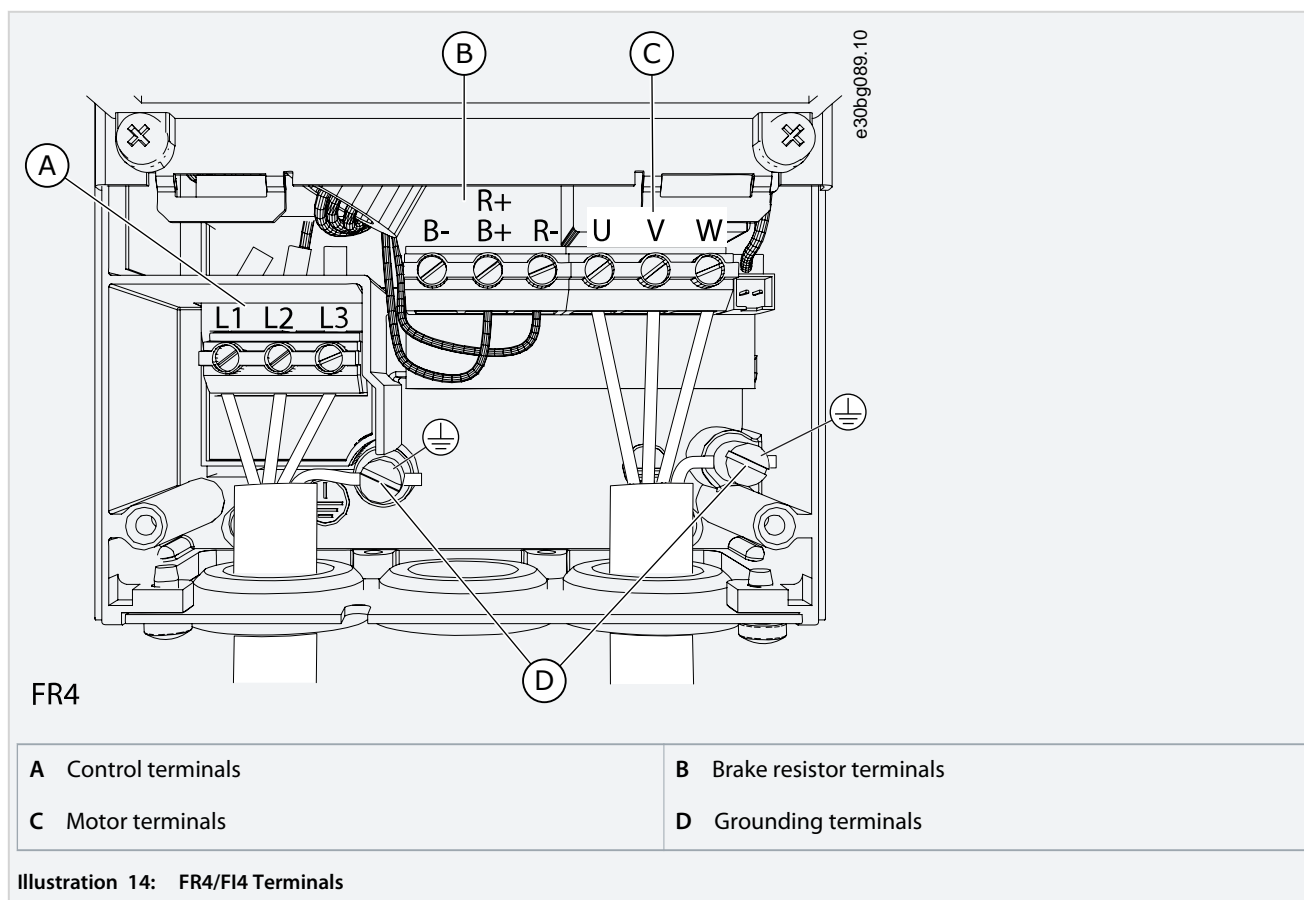

### 6.4.2 Get Access and Locate the Terminals for FR6/FI6

**Context:**

Follow these instructions to open the AC drive for installing the cables, for example.

**Procedure**

1. Open the cover of the AC drive.

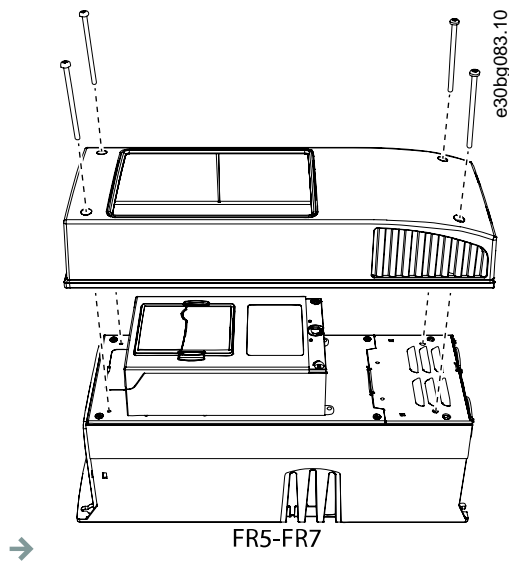

2. Remove the screws of the cable cover. Remove the cable cover. Do not open the cover of the power unit.

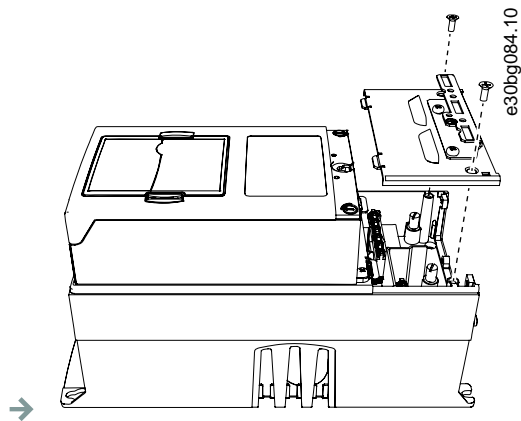

3. Locate the terminals.

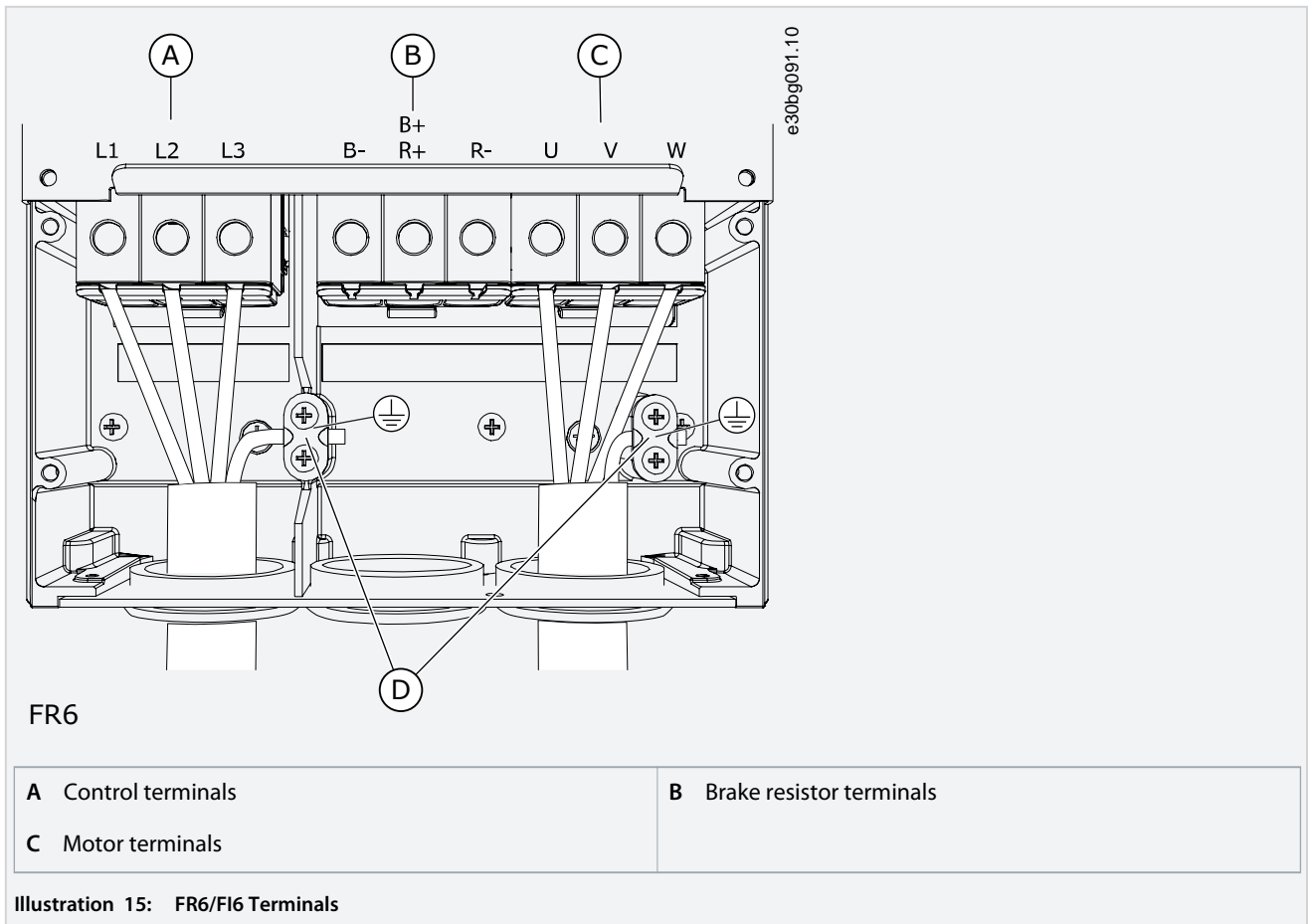

### 6.4.3 Get Access and Locate the Terminals for FR7/FI7

**Context:**

Follow these instructions to open the AC drive for installing the cables, for example.



**Procedure**

1. Open the cover of the AC drive.

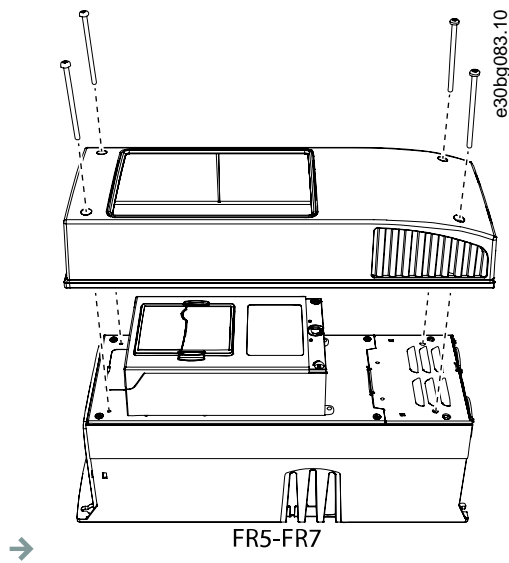

2. Remove the screws of the cable cover. Remove the cable cover. Do not open the cover of the power unit.

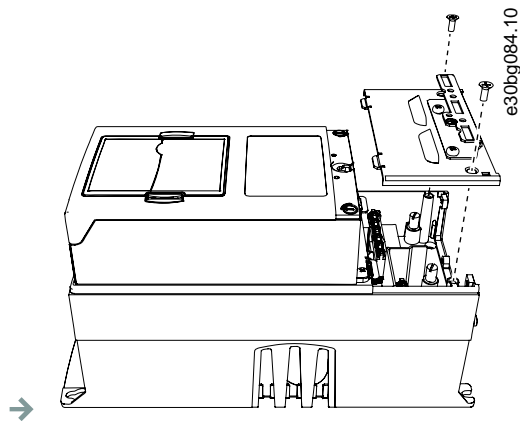

3. Locate the terminals.

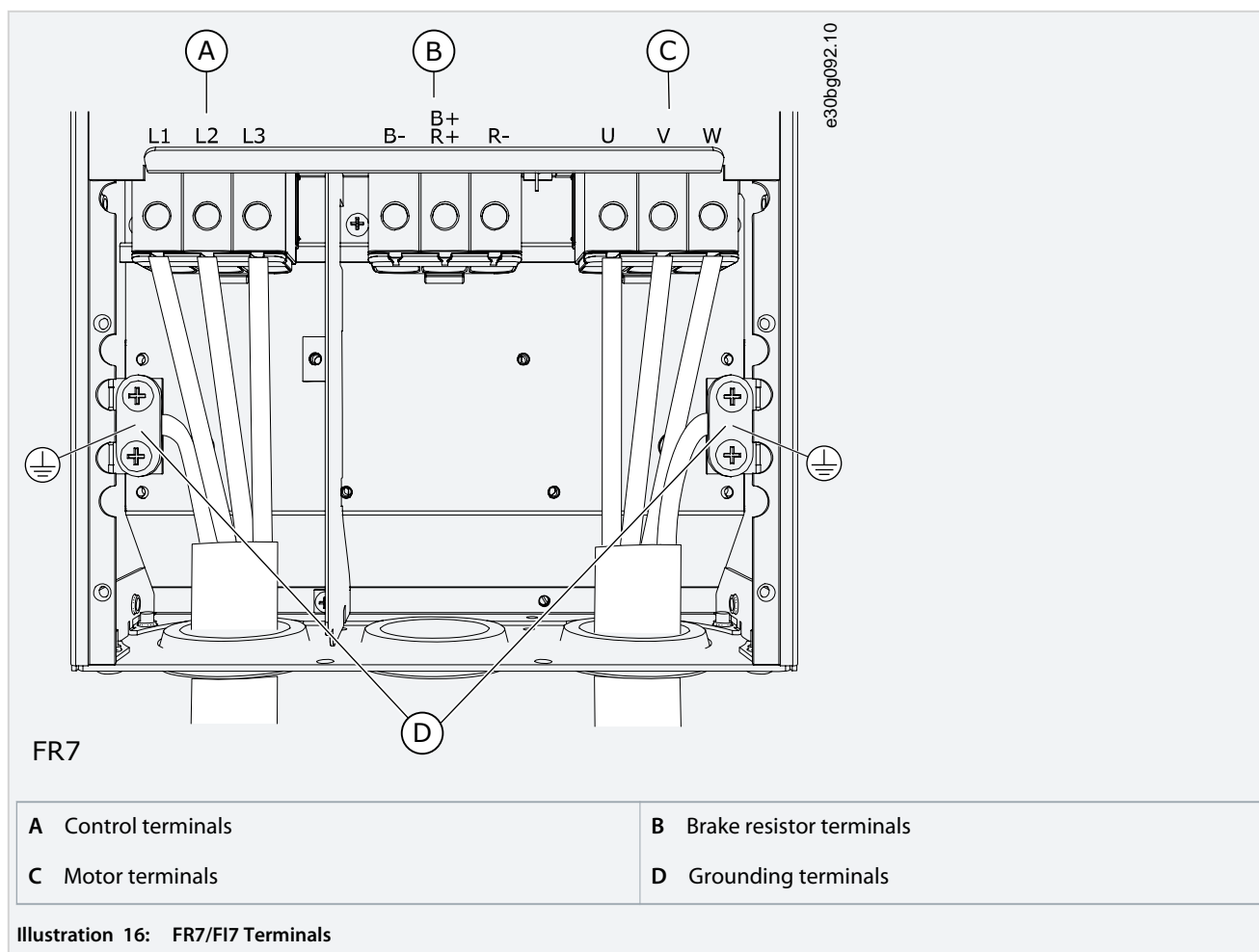

#### 6.4.4 Get Access and Locate the Terminals for FR8/FI8

**Context:**

Follow these instructions to open the AC drive for installing the cables, for example.

**Procedure**

1. Open the cover of the AC drive.

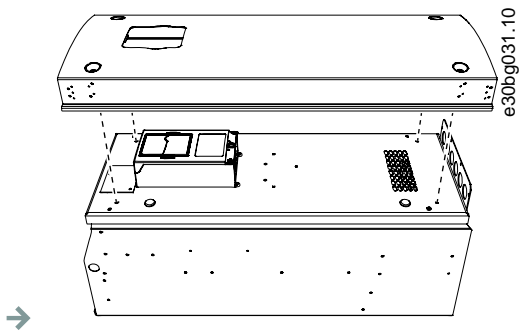

2. Open the power unit cover.

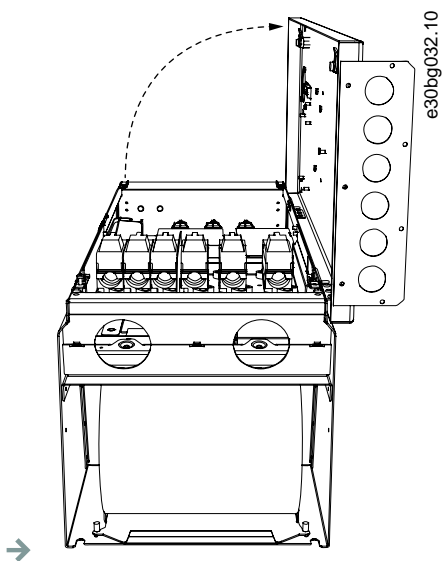

3. Find the DC terminals and Brake resistor terminals on top of the AC drive.

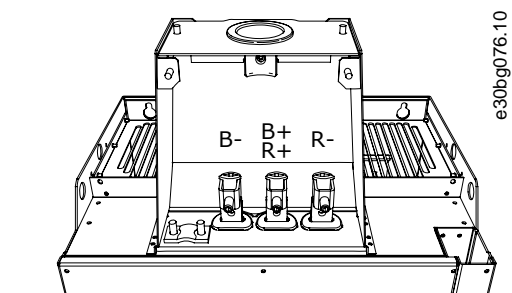

4. Locate the terminals.

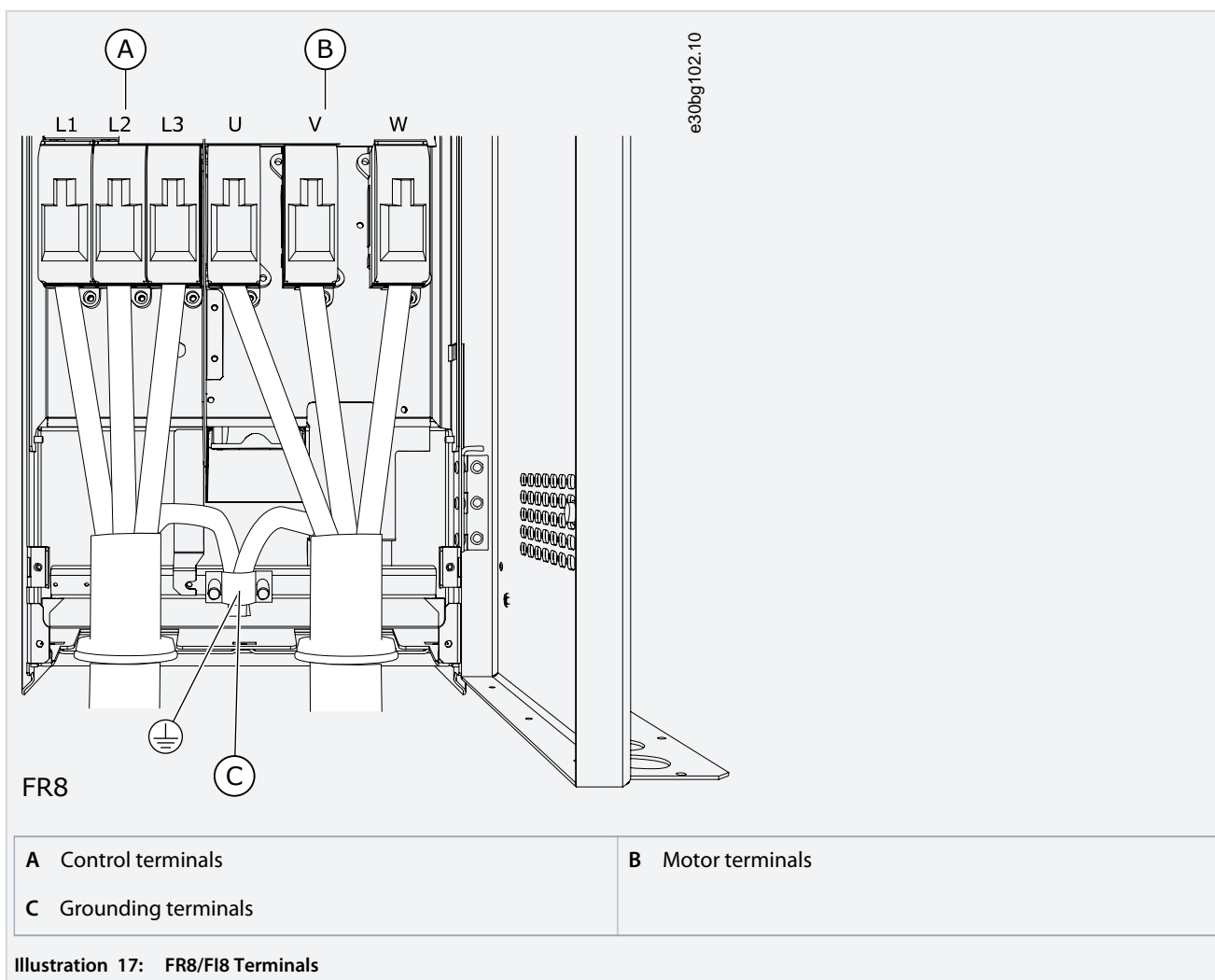

## 6.5 Installing the Cables

### Context:

Use these instructions to find the installation instructions of the correct enclosure size.

### Procedure

1. Check the requirements related to lengths, distances, and positioning of the cables according to instructions in [6.5.1 Additional Instructions for Cable Installation](#).
2. Follow the installation instructions of the correct enclosure size. To check the enclosure size of the AC drive, see [3.7 Enclosure Sizes](#).

- [6.5.2 Installing the Cables, FR4-FR6/FI4-FI6](#)
- [6.5.3 Installing the Cables, FR7/FI7](#)
- [6.5.4 Installing the Cables, FR8/FI8](#)

### 6.5.1 Additional Instructions for Cable Installation

- Before starting, make sure that none of the components of the AC drive is live. Read carefully the warnings in Safety section.
- Make sure that the motor cables are sufficiently far from other cables.
- The motor cables must go across other cables at an angle of 90°.
- If it is possible, do not put the motor cables in long parallel lines with other cables.
- If the motor cables are in parallel with other cables, obey the minimum distances (see [table 9](#)).
- The distances are also valid between the motor cables and the signal cables of other systems.
- The maximum lengths of shielded motor cables are 300 m (984 ft) (AC drives with power greater than 1.5 kW or 2 hp), and 100 m (328 ft) (AC drives with power from 0.75 kW to 1.5 kW or 1–2 hp). If the used motor cables are longer, speak to the factory to get more information.  
Each parallel cable adds to the total length.

NOTICE	
<p>If long motor cables are used (maximum 100 m or 328 ft) together with small drives (<math>\leq 1.5</math> kW or <math>\leq 2.01</math> hp), the capacitive current in the motor cable can increase the measured motor current compared to the actual motor current. Consider it when setting up the motor stall protection functions.</p>	

- If the cable insulation checks are necessary, see [9.3 Measuring the Cable and Motor Insulation](#).

Table 9: Minimum Distances between Cables

The distance between cables [m]	The length of the shielded cable [m]	The distance between cables [ft]	The length of the shielded cable [ft]
0.3	$\leq 50$	1.0	$\leq 164.0$
1.0	$\leq 200$	3.3	$\leq 656.1$

### 6.5.2 Installing the Cables, FR4-FR6/FI4-FI6

**Context:**

Follow these instructions to install the cables and cable accessories.

For information on how to comply with the UL regulations in cable installation, see [6.1.2 UL Standards on Cabling](#).

If it is necessary to connect an external brake resistor, see VACON® Brake Resistor Manual. See also [8.7.8.2 Setting the Internal Brake Resistor Connection](#).

**Prerequisites:**

Make sure that the delivery contains all necessary components. For the installation, the contents of the accessories bag is needed, see [4.1 Checking the Delivery](#).

Open the covers according to instructions in [6.4.1 Get Access and Locate the Terminals for FR4/FI4](#), or [6.4.2 Get Access and Locate the Terminals for FR6/FI6](#).

**Procedure**

1. Strip the DC supply cable, the mains cable, and the brake resistor cable. See [12.4 Cable Stripping Lengths](#).
2. Cut the grommets open to move the cables through them. Use the grommets delivered in the accessories bag.

- Do not cut the grommet openings wider than what is necessary for the used cables.
- If the grommets fold in when putting the cable, pull the cable back to make the grommets straight.
- Use a cable gland as an alternative to the grommet in types where this is necessary.

3. Put the cables - the DC supply cable, the motor cable, and the optional brake cable - in the openings of the cable entry plate. Use the cable entry plate delivered in the accessories bag.

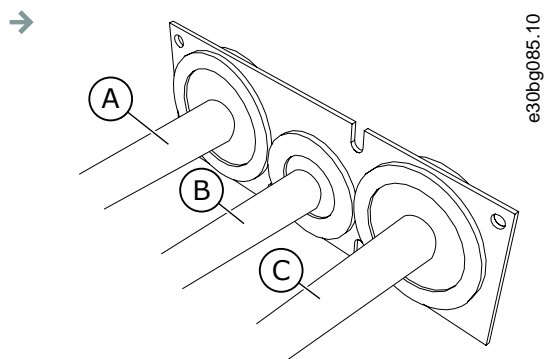

A The DC supply cable	B The brake cable
C The motor cable	

**Illustration 18: Cables through the Cable Entry Plate**

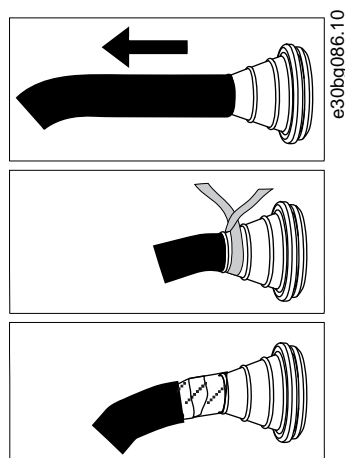

4. Put the cable entry plate with the cables into the groove on the frame of the drive. To attach the cable entry plate, use the M4x10 screws delivered in the accessories bag.

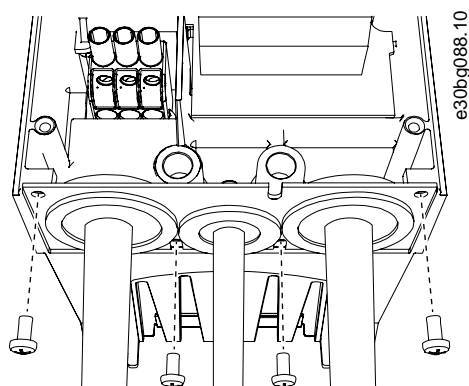

5. Connect the cables. See the correct tightening torques in [12.6 Tightening Torques of the Terminals](#).

- Connect the phase conductors of the DC supply cable and of the motor cable, and the conductors of the brake resistor cable into the correct terminals.
- FR4/FI4, FR5: Attach the grounding conductor of each cable to a grounding terminal with a grounding clamp for grounding conductor. Use the grounding terminals delivered in the accessories bag.
- FR6/FI6: Attach the grounding conductor of each cable to a grounding terminal with a grounding clamp for grounding conductor. Use the grounding clamps and the screws delivered in the accessories bag.

6. Make sure to connect the grounding conductor to the motor and the terminals that are identified with the grounding symbol.

- For FR4/FI4 and FR5: Two protective conductors are necessary to comply with the requirements of the standard IEC/EN 61800-5-1. See [6.2 Grounding](#).
- If a double grounding is necessary, use the grounding terminal below the drive. Use an M5 screw and tighten it to 2.0 Nm or 17.7 lb-in.

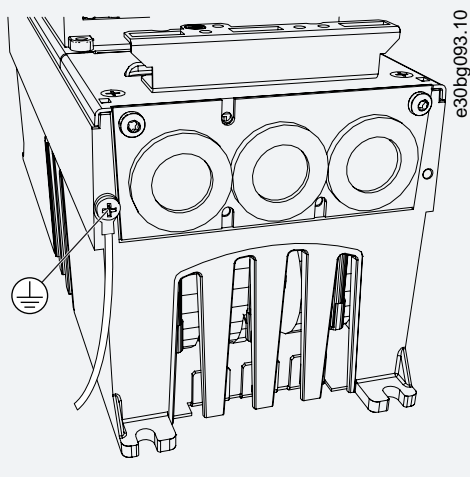

7. Attach the cable cover [12.5 Tightening Torques for Cover Screws](#). Attach the grounding clamps for control cable with 3 pieces of M4x16 screws delivered in the accessories bag. Use these clamps to ground the control cables.

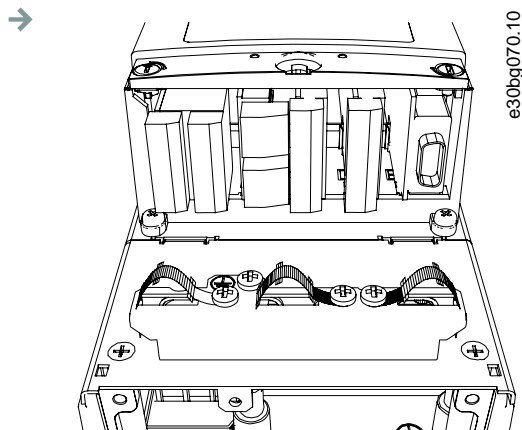

Illustration 19: FR4-FR6/FI4-FI6

8. Attach the cover of the drive. For the tightening torques of the screws, see [12.5 Tightening Torques for Cover Screws](#). Make sure that the control cables or the cables of the AC drive are not caught between the frame and the cable cover.

### 6.5.3 Installing the Cables, FR7/FI7

#### Context:

Follow these instructions to install the cables and cable accessories.'

For information on how to comply with the UL regulations in cable installation, see [6.1.2 UL Standards on Cabling](#).

If it is necessary to connect an external brake resistor, see VACON® Brake Resistor Manual. See also [8.7.8.2 Setting the Internal Brake Resistor Connection](#).

#### Prerequisites:

Make sure that the delivery contains all necessary components. For the installation, the contents of the accessories bag is needed, see [4.1 Checking the Delivery](#).

Open the covers according to instructions in [6.4.3 Get Access and Locate the Terminals for FR7/FI7](#).



**Procedure**

1. Strip the motor cable, the mains cable, and the brake resistor cable. See [12.4 Cable Stripping Lengths](#).
2. Cut the grommets open to move the cables through them. Use the grommets delivered in the accessories bag.
  - Do not cut the grommet openings wider than what is necessary for the used cables.
  - If the grommets fold in when putting the cable, pull the cable back to make the grommets straight.
  - Use a cable gland as an alternative to the grommet in types where this is necessary.
3. Put the cables - the DC supply cable, the motor cable, and the optional brake cable - in the openings of the cable entry plate. Use the cable entry plate delivered in the accessories bag.

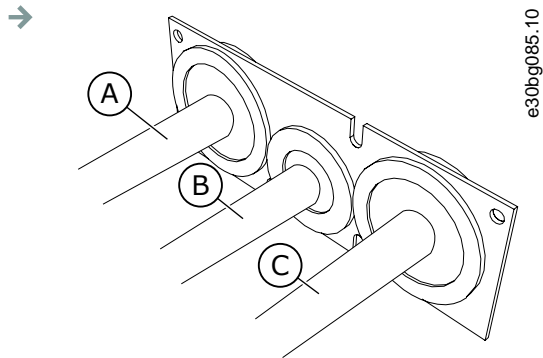

A The DC supply cable	B The brake cable
C The motor cable	

**Illustration 20: Cables through the Cable Entry Plate**

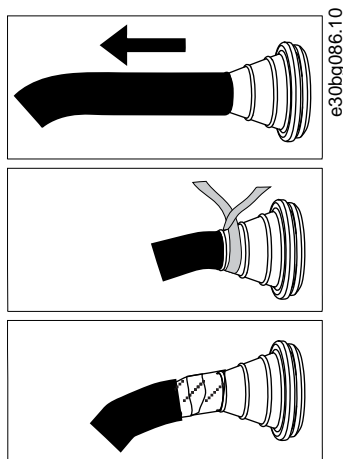

4. Put the cable entry plate with the cables into the groove on the frame of the drive. To attach the cable entry plate, use the M4x10 screws delivered in the accessories bag.

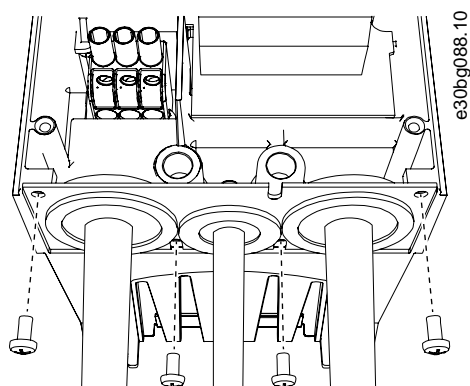

5. Connect the cables. See the correct tightening torques in [12.6 Tightening Torques of the Terminals](#).

- Connect the phase conductors of the DC supply cable and of the motor cable, and the conductors of the brake resistor cable into the correct terminals.

6. Make sure to connect the grounding conductor to the motor and the terminals that are identified with the grounding symbol.

- If a double grounding is necessary, use the grounding terminal below the drive. Use an M5 screw and tighten it to 2.0 Nm or 17.7 lb-in.

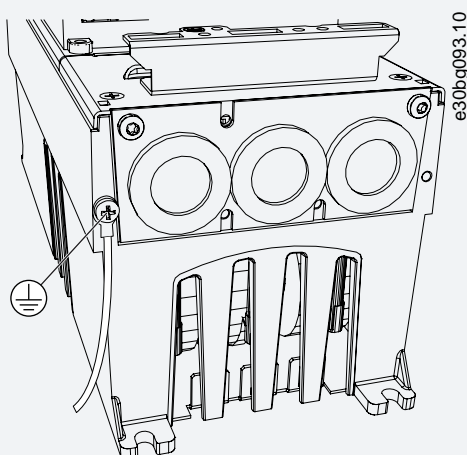

7. Attach the cable cover [12.5 Tightening Torques for Cover Screws](#). Attach the grounding clamps for control cable with 3 pieces of M4x16 screws delivered in the accessories bag. Use these clamps to ground the control cables.

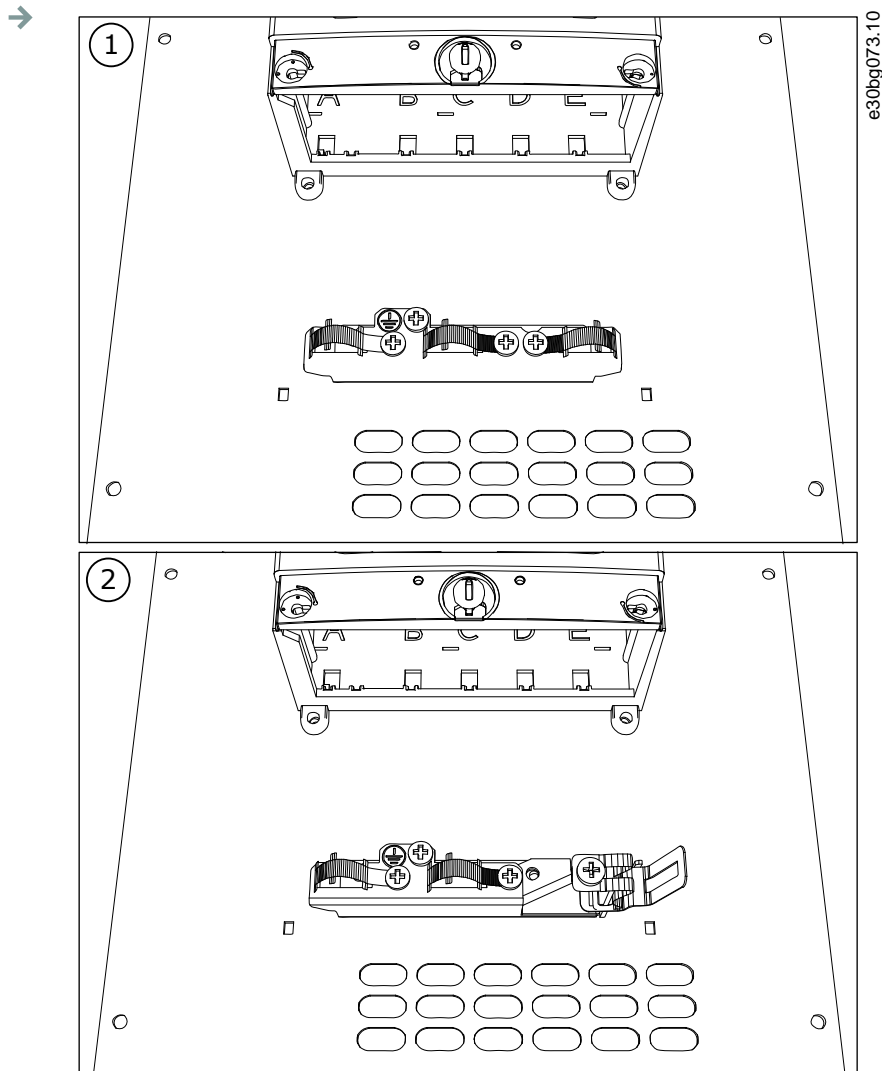

1 Standard	2 PROFIBUS
------------	------------

Illustration 21: FR7/FI7

- Attach the cover of the drive. For the tightening torques of the screws, see [12.5 Tightening Torques for Cover Screws](#). Make sure that the control cables or the cables of the AC drive are not caught between the frame and the cable cover.

### 6.5.4 Installing the Cables, FR8/FI8

**Context:**

Follow these instructions to install the cables and cable accessories.

For information on how to comply with the UL regulations in cable installations, see [6.1.2 UL Standards on Cabling](#).

If it is necessary to connect an external brake resistor, see VACON® Brake Resistor Manual. See also [8.7.8.2 Setting the Internal Brake Resistor Connection](#).

**Prerequisites:**

Make sure that the delivery contains all necessary components. For the installation, the contents of the accessories bag is needed, see [4.1 Checking the Delivery](#).

Open the covers according to instructions in [6.4.4 Get Access and Locate the Terminals for FR8/FI8](#).

**Procedure**

1. Strip the motor cable, the DC supply cable, and the brake resistor cable. See [12.4 Cable Stripping Lengths](#).
2. To move the cables through the grommets, cut them open. Use the grommets delivered in the accessories bag.

- Do not cut the grommet openings wider than what is necessary for the used cables.
- If the grommets fold in when putting the cable, pull the cable back to make the grommets straight.
- Use a grommet as an alternative to the grommet in types where it is necessary.

3. Attach the grommet and the cable until the frame of the drive goes into the groove of the grommet.

- With the protection rating IP54 (UL Type 12), the connection between the grommet and the cable must be tight. Pull the first bit of the cable out of the grommet until it stays straight.
- If it is not possible, make the connection tight with some insulation tape or a cable tie.

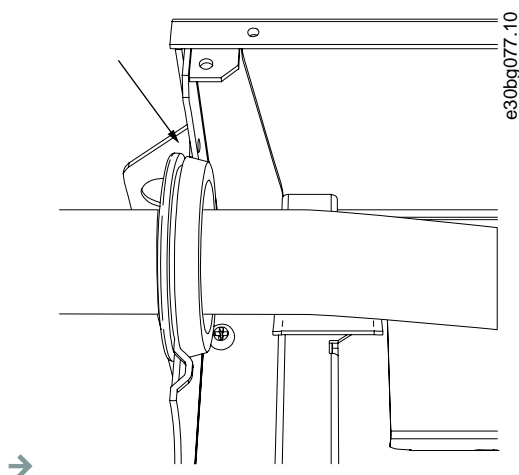

4. Connect the cables. See the correct tightening torques in [12.6 Tightening Torques of the Terminals](#).

- Connect the phase conductors of the DC supply cable and of the motor cable into the correct terminals. If a brake resistor cable is used, connect its conductors into the correct terminals.
- Attach the grounding conductor of each cable to a grounding terminal with a grounding clamp for grounding conductor.

5. To make a 360° connection with the grounding clamp for cable shield, expose the shield of all cables.

6. Attach the cable entry plate, and then the cable cover. For the tightening torques of the screws, see [12.5 Tightening Torques for Cover Screws](#). Make sure that the control cables or the cables of the AC drive are not caught between the frame and the cable cover.

**Additional tightening torques:**

- motor cable entry plate: 2.4 Nm
- control cable entry plate: 0.8 Nm
- DC cover: 2.4 Nm

7. Attach the grounding clamps for control cable on the grounding level with M4x16 screws. Use the clamps delivered in the accessories bag. Use the clamps to ground the control cables.

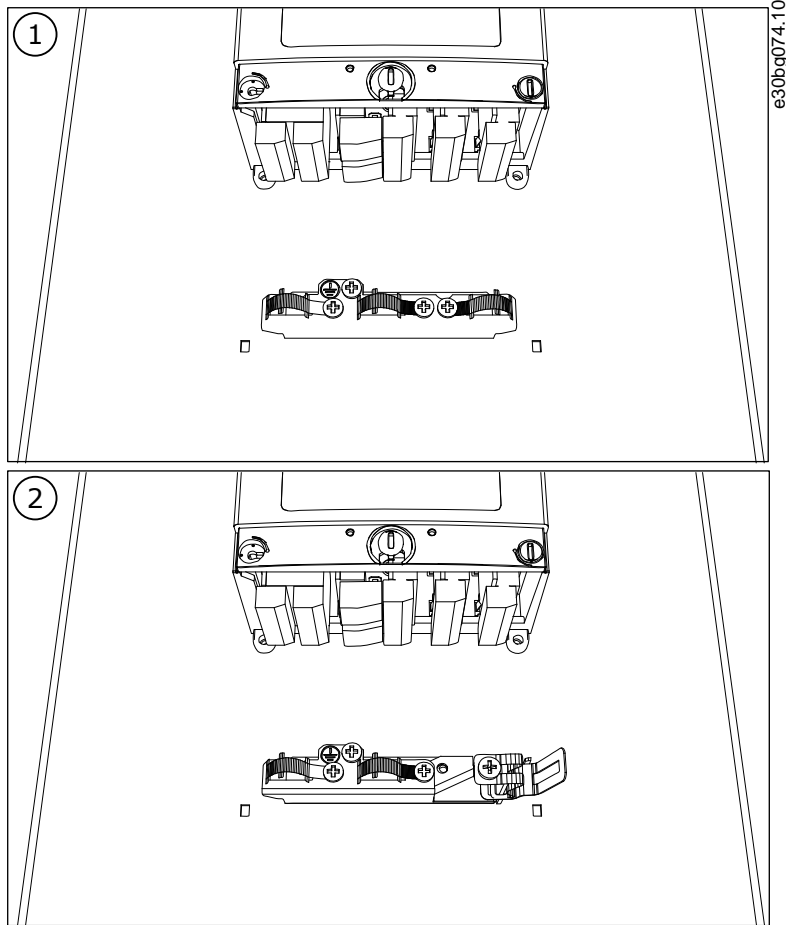

1 Standard	2 PROFIBUS
------------	------------

Illustration 22: FR8/F18

8. Attach the cover of the drive. For the tightening torques of the screws, see [12.5 Tightening Torques for Cover Screws](#).

## 7 Control Unit

### 7.1 Control Unit Components

The control unit of the AC drive contains the control board and additional boards (see [illustration 23](#)) connected to the 5 slot connectors (A to E) of the control board. The control board is connected to the power unit through a D-connector or fiber optic cables (FR9).

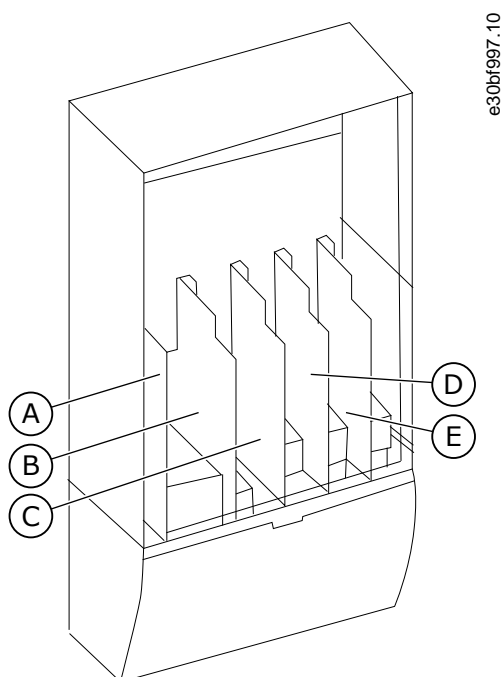

**Illustration 23:** Basic and Option Slots on the Control Board

The control unit of the delivered AC drive contains the standard control interface. If the order included special options, the AC drive is delivered according to the order. The next pages contain information on the terminals and general wiring examples. The type code shows the I/O boards that are installed at the factory. For more information on the option boards, see VACON® NX I/O Boards User manual.

The OPTA1 basic board has 20 control terminals, and the relay board has 6 or 7. The standard connections of the control unit and the descriptions of signals are shown in [7.3.2 Control Terminals on OPTA1](#).

For instructions on how to install the control unit that is not attached to the power unit, see VACON® NXP IP00 Drives Installation Manual.

### 7.2 Control Voltage (+24 V/EXT +24 V)

It is possible to use the drive with an external power source with these properties: +24 V DC  $\pm 10\%$ , minimum 1000 mA. Use it to externally power up the control board, and the basic and option boards. The analog outputs and inputs at OPTA1 do not work with only +24 V supplied to the control unit.

Connect the external power source to one of the 2 bidirectional terminals (#6 or #12), see the option board manual or VACON® NX I/O Boards User Manual. With this voltage, the control unit stays on and parameters can be set. The measurements of the main circuit (for example, the DC-link voltage, and the unit temperature) are not available when the drive is not connected to mains.

**NOTICE**

If the AC drive is supplied with external 24 V DC power, use a diode in terminal #6 (or #12) to prevent the current to flow in opposite direction. Put a 1 A fuse in 24 V DC line for each AC drive. The maximum current consumption of each drive is 1 A from the external supply.

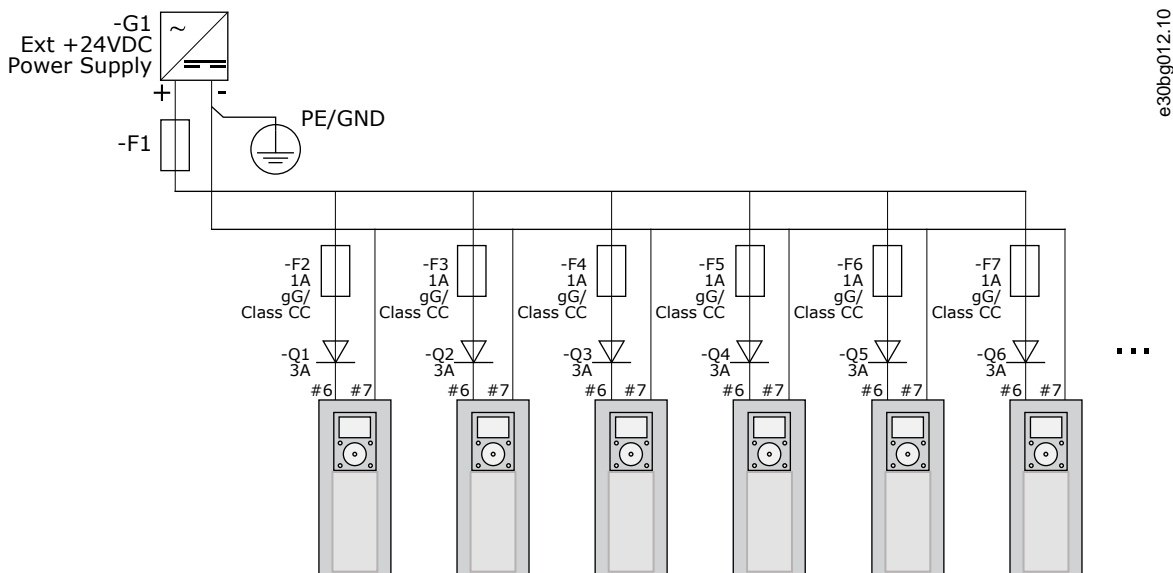

Illustration 24: Parallel Connection of 24 V Inputs with Many AC Drives

**NOTICE**

The control unit I/O ground is not isolated from the chassis ground/protective earth. In the installation, consider the potential differences between the grounding points. We recommend using galvanic isolation in the I/O and 24 V circuitry.

### 7.3 Control Unit Cabling

#### 7.3.1 Selection of the Control Cables

The control cables must be a minimum of 0.5 mm<sup>2</sup> (20 AWG) shielded multicore cables. See more on the cable types in [table 8](#). The terminal wires must be a maximum of 2.5 mm<sup>2</sup> (14 AWG) for the terminals of the relay board and 1.5 mm<sup>2</sup> (16 AWG) for other terminals.

Table 10: Tightening Torques of the Control Cables

The terminal	The terminal screw	The tightening torque in Nm (lb-in.)
Relay and thermistor terminals	M3	0.5 (4.5)
Other terminals	M2.6	0.2 (1.8)



### 7.3.2 Control Terminals on OPTA1

The figure shows the basic description of the terminals of the I/O board. For more information, see [7.3.2.2 Jumper Selections on the OPTA1 Basic Board](#). For more information on control terminals, see VACON® All in One Application manual.

Standard I/O board				
Terminal	Signal	Description		
1	+10V <sub>ref</sub>	Reference voltage	Maximum current 10 mA	
2	AI1+	Analogue input, voltage or current	Selection V/mA with jumper block X1 (*) 0...+10 V (Ri = 200 kΩ) (-10V...+10V Joystick ctrl, sel. with jumper) 0-20 mA (Ri =250 Ω)	
3	GND/AI1-	Analogue input common	Differential input if not connected to ground Allows ±20 V common mode voltage to GND	
4	AI2+	Analogue input, voltage or current	Selection V/mA with jumper block X1 (*) 0...+10 V (Ri = 200 kΩ) (-10V...+10V Joystick ctrl, sel. with jumper) 0-20 mA (Ri =250 Ω)	
5	GND/AI2-	Analogue input common	Differential input if not connected to ground Allows ±20 V common mode voltage to GND	
6	+24V	24 V aux. voltage	±15%, max. 250 mA (all boards total) 150 mA (from single board) Can also be used as external power back-up for the control unit (and fieldbus)	
7	GND	I/O ground	Ground for reference and controls	
8	DIN1	Digital input 1	Ri = min. 5 kΩ 18-30 V = 1	
9	DIN2	Digital input 2		
10	DIN3	Digital input 3		
11	CMA	Common A for DIN1—DIN3	Digital inputs can be disconnected from ground (†)	
12	+24V	Control voltage output	Same as terminal #6	
13	GND	I/O ground	Same as terminal #7	
14	DIN4	Digital input 4	Ri = min. 5 kΩ 18-30 V = 1	
15	DIN5	Digital input 5		
16	DIN6	Digital input 6		
17	CMB	Common B for DIN4-DIN6	Must be connected to GND or 24 V of I/O term. or to ext. 24 V or GND Selection with jumper block X3 (*)	
18	AO1+	Analogue signal (+output)	Output signal range: Current 0(4)-20 mA, RL max 500 Ω or Voltage 0-10 V, RL >1kΩ Selection with jumper block X6 (*)	
19	AO1-	Analogue output common		
20	DO1	Open collector output	Maximum Uin = 48 VDC Maximum current = 50 mA	

e30bg013.10

\*) See figure in [7.3.2.2 Jumper Selections on the OPTA1 Basic Board](#)

Illustration 25: Control Terminal Signals on OPTA1

Parameter references for I/O on control panel and NCDriver are: An.IN:A.1, An.IN:A.2, DigIN:A.1, DigIN:A.2, DigIN:A.3, DigIN:A.4, DigIN:A.5, DigIN:A.6, AnOUT:A.1 and DigOUT:A.1.

To use the control voltage output +24 V/EXT+24 V:

- wire the +24 V control voltage to digital inputs through an external switch. OR
- use the control voltage to power up external equipment, such as encoders and auxiliary relays.

The specified total load on all available +24 V/EXT+24 V output terminals must not exceed 250 mA.

The maximum load on the +24 V/EXT+24 V output per board is 150 mA. If there is a +24 V/EXT+24 V output on the board, it is locally short circuit protected. If one of the +24 V/EXT+24 V outputs short circuits, the others remain powered because of the local protection.

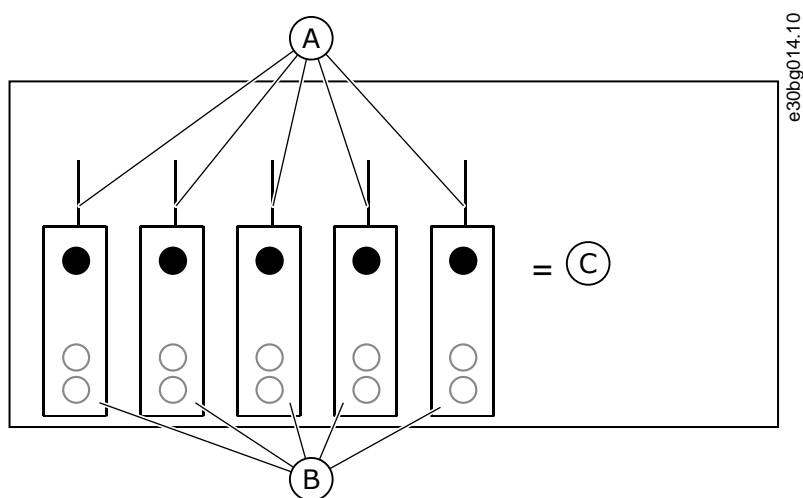

A	Maximum 150 mA	B	+24 V out
C	Maximum 250 mA		

Illustration 26: Maximum Loads on +24 V/EXT+24 V Output

### 7.3.2.1 Digital Input Signal Inversions

The active signal level is different when the common inputs CMA and CMB (terminals 11 and 17) are connected to +24 V or to ground (0 V).

The 24 V control voltage and the ground for the digital inputs and the common inputs (CMA, CMB) can be internal or external.

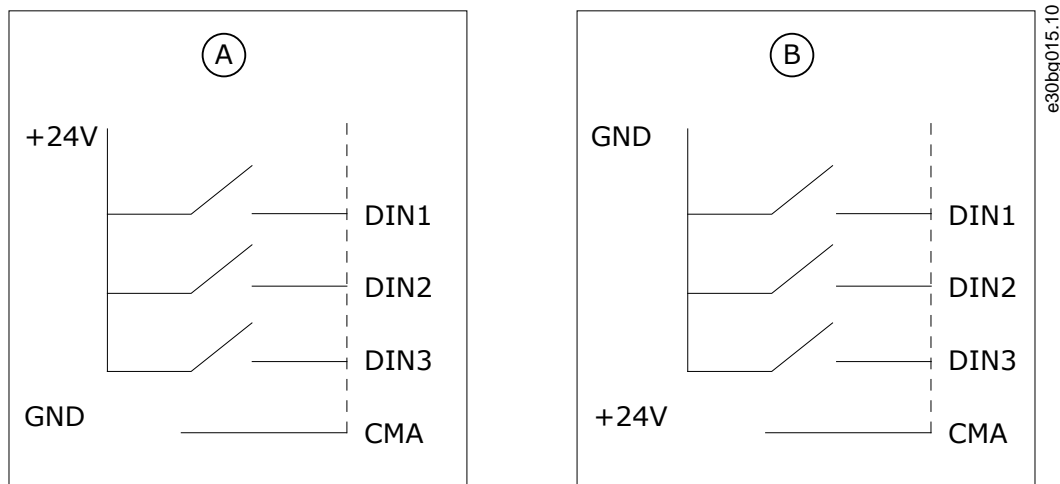

e30bg015.10

- |  |  |
|--|--|
| <p><b>A</b> Positive logic (+24 V is the active signal) = the input is active when the switch is closed.</p> | <p><b>B</b> Negative logic (0 V is the active signal) = the input is active when the switch is closed. Set the jumper X3 to the position 'CMA/CMB isolated from ground'.</p> |
|--|--|

Illustration 27: Positive/Negative Logic

### 7.3.2.2 Jumper Selections on the OPTA1 Basic Board

The functions of the AC drive can be changed to make them better agree with local requirements. To do it, change some positions for the jumpers on the OPTA1 board. The positions of the jumpers set the signal type of analog and digital inputs. Changing the AI/AO signal contents requires also a change in the related board parameter in menu M7.

On the A1 basic board, there are 4 jumper blocks: X1, X2, X3, and X6. Each jumper block contains 8 pins and 2 jumpers. See the possible jumper selections in [illustration 28](#).

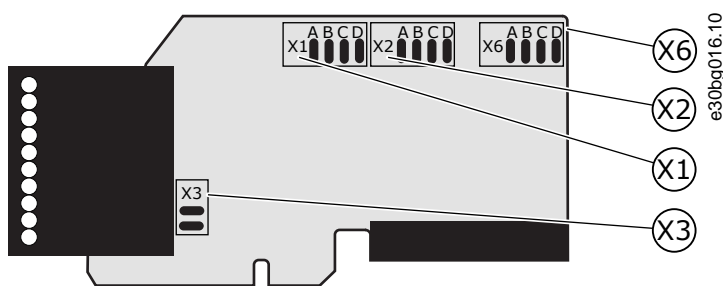

e30bg016.10

Illustration 28: Jumper Blocks on OPTA1

e30b9017.10

Jumper block X1:  
AI1 mode

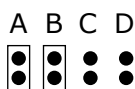

AI1 mode: 0...20mA; Current input

Jumper block X2:  
AI2 mode

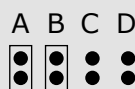

AI1 mode: 0...20mA; Current input

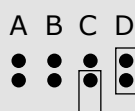

AI1 mode: Voltage input; 0...10V

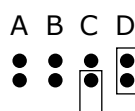

AI2 mode: Voltage input; 0...10V

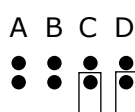

AI1 mode: Voltage input; 0...10V differential

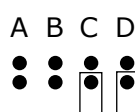

AI2 mode: Voltage input; 0...10V differential

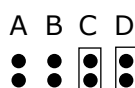

AI1 mode: Voltage input; -0...10V

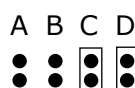

AI2 mode: Voltage input; -10...10V

Jumper block X6:  
AO1 mode

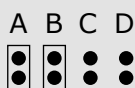

AO1 mode: 0...20mA; Current output

Jumper block X3:  
CMA and CMB grounding

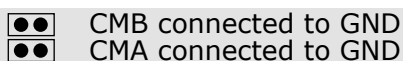

= Factory default

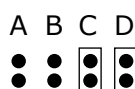

AO1 mode: Voltage output; 0...10V

Illustration 29: Jumper Selections for OPTA1

### 7.3.3 Control Terminals on OPTA2 and OPTA3

OPTA2			
21	RO1/1	Relay output 1 DigOUT:B.1 *)	Switching capacity • 24 VDC/8 A • 250 VAC/8 A • 125 VDC/0.4 A Minimum switching load • 5 V/10 mA
22	RO1/2		
23	RO1/3		
24	RO2/1	Relay output 2 DigOUT:B.2 *)	Switching capacity • 24 VDC/8 A • 250 VAC/8 A • 125 VDC/0.4 A Minimum switching load • 5 V/10 mA
25	RO2/2		
26	RO2/3		
OPTA3			
21	RO1/1	Relay output 1 DigOUT:B.1 *)	Switching capacity • 24 VDC/8 A • 250 VAC/8 A • 125 VDC/0.4 A Minimum switching load • 5 V/10 mA
22	RO1/2		
23	RO1/3		
25	RO2/1	Relay output 2 DigOUT:B.2 *)	Switching capacity • 24 VDC/8 A • 250 VAC/8 A • 125 VDC/0.4 A Minimum switching load • 5 V/10 mA
26	RO2/2		
28	TI1+		
29	TI1-		

e30bg018.10

\*) Parameter reference on control panel and NCDrive.

Illustration 30: Control Terminal Signals on Relay Boards OPTA2 and OPTA3

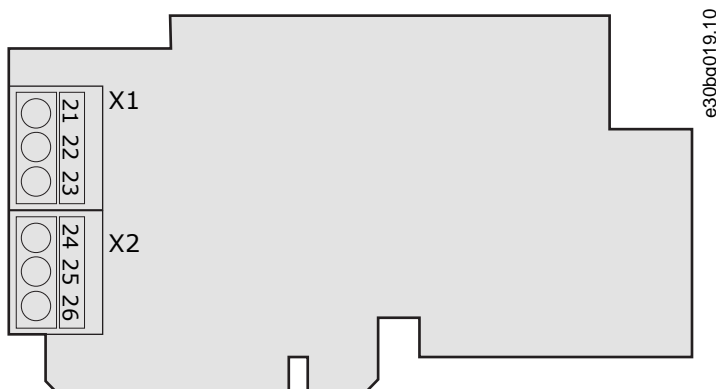

e30bg019.10

Illustration 31: OPTA2

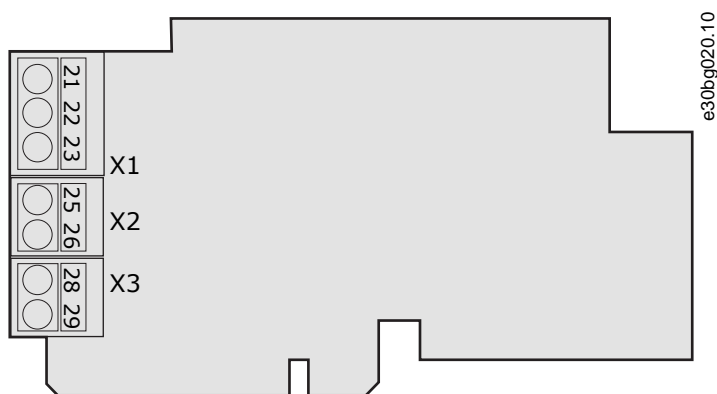

Illustration 32: OPTA3

## 7.4 Installation of Option Boards

For information on how to install the option boards, see the option board manual or VACON® NX I/O Boards User Manual.

## 7.5 Galvanic Isolation Barriers

The control connections are isolated from mains. The GND terminals are permanently connected to I/O ground. See [illustration 33](#).

The digital inputs on the I/O board are galvanically isolated from the I/O ground. The relay outputs are also double-isolated from each other at 300 VAC (EN-50178).

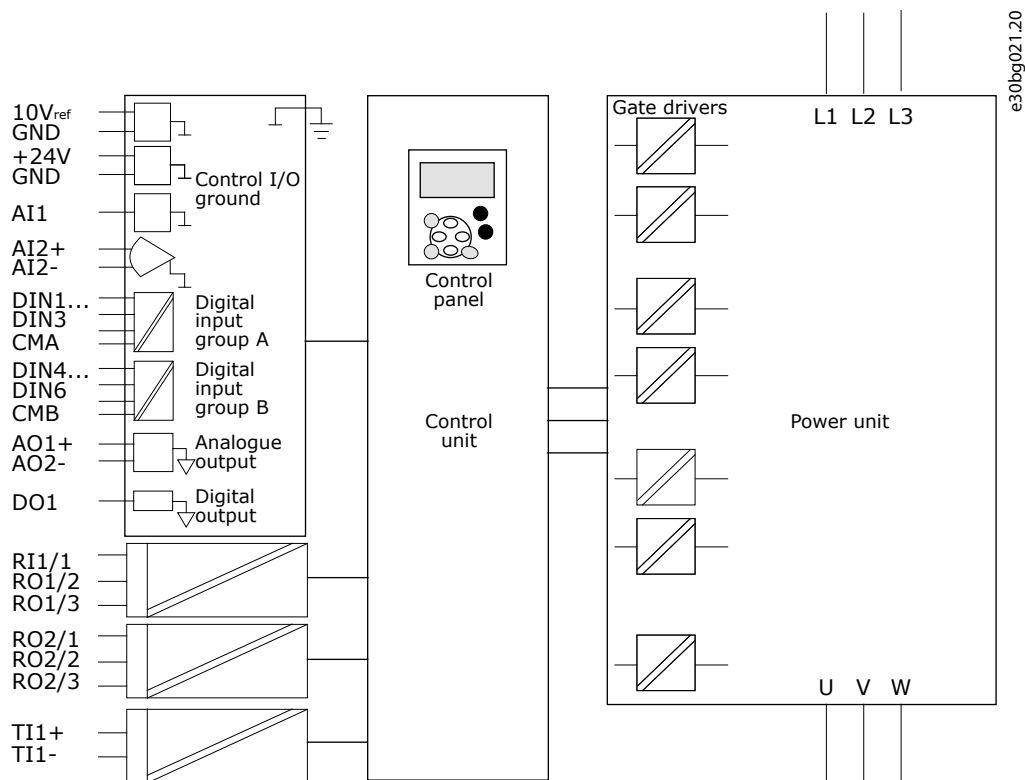

Illustration 33: Galvanic Isolation Barriers

## 8 Using the Control Panel

### 8.1 Navigating on the Control Panel

**Context:**

The data of the AC drive is in menus and submenus. Follow these instructions to navigate in the menu structure on the control panel.

**Procedure**

1. To move between the menus, use the Browser buttons Up and Down on the keypad.
2. To go into a group or an item, push the Menu button Right.

To go back to the previous level, push the Menu button Left.

- The display shows the current location in the menu, for example S6.3.2. The display also shows the name of the group or item in the current location.

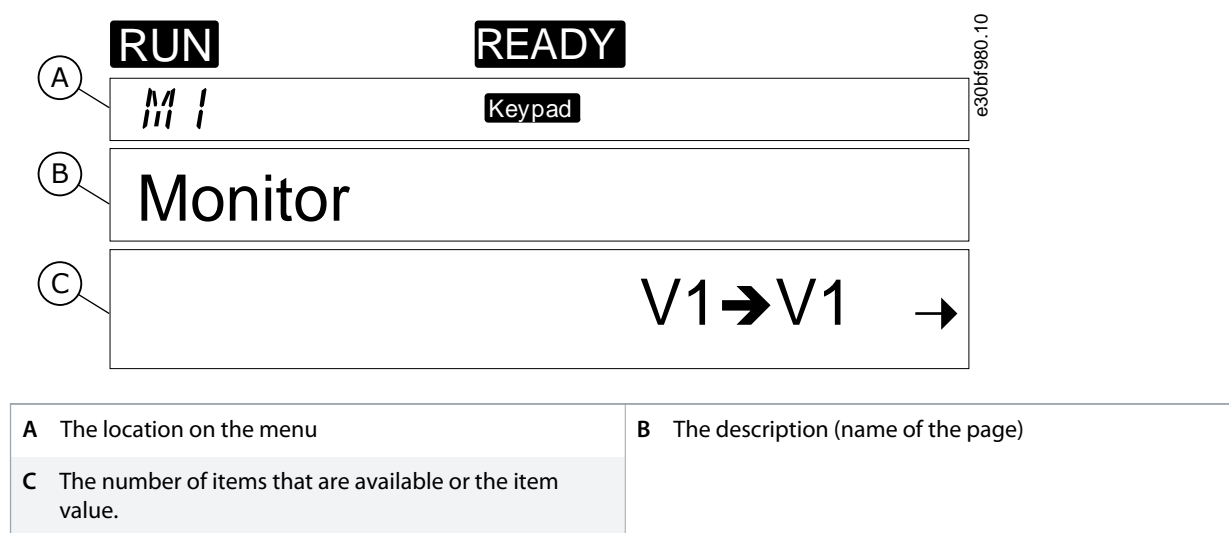

Illustration 34: Navigation Items on the Control Panel

### 8.2 Using the Monitoring Menu (M1)

**Context:**

Follow these instructions to monitor the actual values of the parameters and signals.

The values cannot be changed in the Monitoring menu. To change the values of parameters, see [8.3.2 Selecting Values](#) or [8.3.3 Editing the Values Digit by Digit](#).



**Procedure**

1. To find the Monitoring menu, scroll down in the main menu until the location indication *M1* shows on the first line of the display.

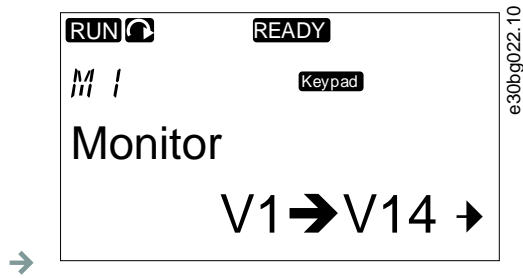

2. To go to the Monitoring menu from the main menu, push the Menu button Right.
3. To scroll through the menu, push the Browser buttons Up and Down.

### 8.2.1 Monitored Values

The monitored values have the indication V#.#. The values update each 0.3 s.

Index	Monitored value	Unit	ID	Description
V1.1	Output frequency	Hz	1	The output frequency to the motor
V1.2	Frequency reference	Hz	25	The frequency reference to motor control
V1.3	Motor speed	rpm	2	The actual speed of the motor in rpm
V1.4	Motor current	A	3	Measured motor current
V1.5	Motor torque	%	4	The calculated shaft torque
V1.6	Motor power	%	5	The calculated motor shaft power in percentage
V1.7	Motor voltage	V	6	The output voltage to the motor
V1.8	DC link voltage	V	7	The measured voltage in the DC-link of the drive
V1.9	Unit temperature	°C	8	The heat sink temperature in Celsius or Fahrenheit
V1.10	Motor temperature	%	9	The calculated motor temperature in percentage of the nominal temperature. See VACON® All in One Application Manual.
V1.11	Analog input 1	V/mA	13	AI1 <sup>(1)</sup>
V1.12	Analog input 2	V/mA	14	AI2 <sup>(1)</sup>
V1.13	DIN 1, 2, 3		15	Shows the status of the digital inputs 1–3
V1.14	DIN 4, 5, 6		16	Shows the status of the digital inputs 4–6
V1.15	DO1, RO1, RO2		17	Shows the status of the digital and relay outputs 1–3
V1.16	Analog I <sub>out</sub>	mA	26	AO1
V1.17	Multimonitored items			Shows 3 monitored values to select from. See <a href="#">8.7.6.9 Enabling/Disabling the Change of Multimonitored Items</a> .

<sup>1</sup> If the AC drive only has +24 V supply (for control board power-up), this value is not reliable.

See VACON® All in One Application Manual for more monitored values.

## 8.3 Using the Parameter Menu (M2)

### 8.3.1 Finding the Parameter

#### Context:

Use these instructions to find the parameter to edit.

**Procedure**

1. To find the Parameter menu, scroll down in the main menu until the location indication *M2* shows on the first line of the display.



2. Push the Menu button Right to move into the Parameter Group Menu (G#).

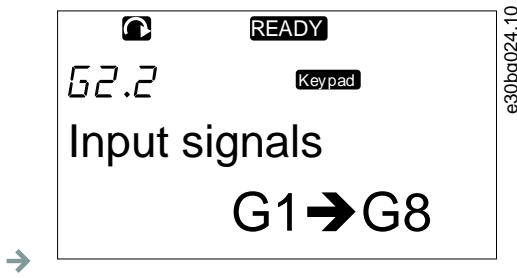

3. To find the parameter group, use the Browser buttons Up and Down.



4. Use the Browser buttons Up and Down to find the parameter (P#) to edit. To move directly from the last parameter of a parameter group to the first parameter of that group, push the Browser button Up.

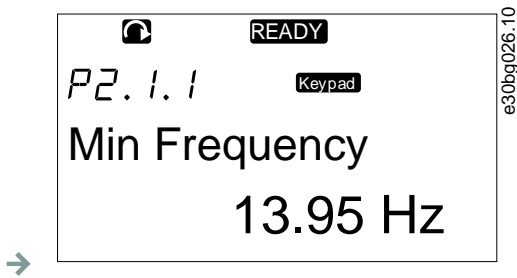

### 8.3.2 Selecting Values

**Context:**

Use these instructions to edit the text values on the control panel.

The basic application package "All in One+" includes 7 applications with different sets of parameters. For more information, see VACON® All in One Application Manual.

**Prerequisites:**

When the drive is in RUN state, many parameters are locked, and cannot be edited. Only the text *Locked* shows on the display. Stop the AC drive to edit these parameters.

**Procedure**

1. Use the Browser buttons Up and Down to find the parameter (P#) to edit. To move directly from the last parameter of a parameter group to the first parameter of that group, push the Browser button Up.

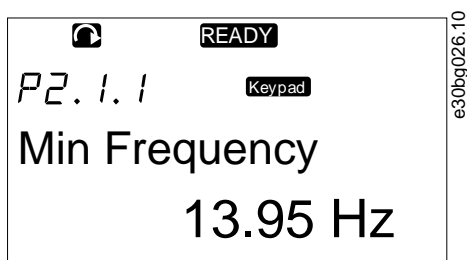

2. To go to the Edit mode, push the Menu button Right. The parameter value starts to blink.

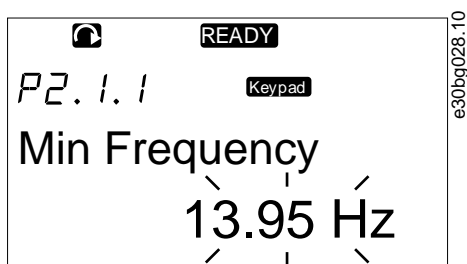

3. Set the new value with the Browser buttons Up and Down.
4. To accept the change, push the [enter] button or ignore the change with menu button Left.
  - If the [enter] button is pushed, the value stops to blink and the new value shows in the value field.

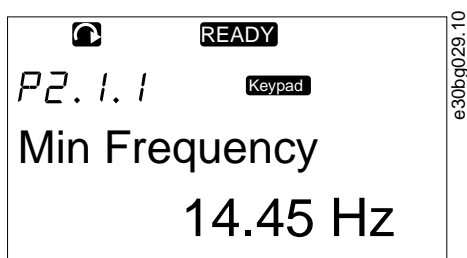

5. For locking the parameter values, use the *Parameter Lock* function in menu M6, see [8.7.6.6 Locking a Parameter](#).

### 8.3.3 Editing the Values Digit by Digit

**Context:**

Use these instructions to edit the numerical values on the control panel.

The basic application package "All in One+" includes 7 applications with different sets of parameters. For more information, see VACON® All in One Application Manual.

**Prerequisites:**

When the drive is in RUN state, many parameters are locked, and cannot be edited. Only the text *Locked* shows on the display. Stop the AC drive to edit these parameters.

#### Procedure

1. Find the parameter with the Browser and Menu buttons.

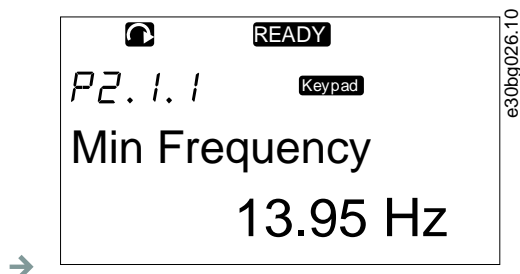

2. To go to the Edit mode, push the Menu button Right. The parameter value starts to blink.

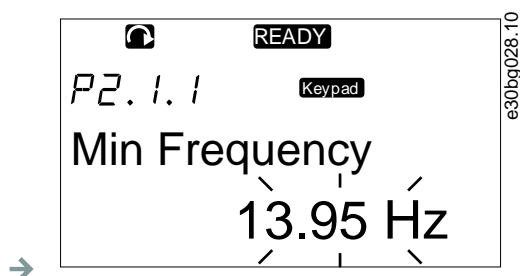

3. Push the Menu button Right. The value can now be edited digit by digit.
4. To accept the change, push the [enter] button.

To ignore the change, push Menu button Left many times, until the view goes back to the parameter list.

- If the [enter] button is pushed, the value stops to blink and the new value shows in the value field.

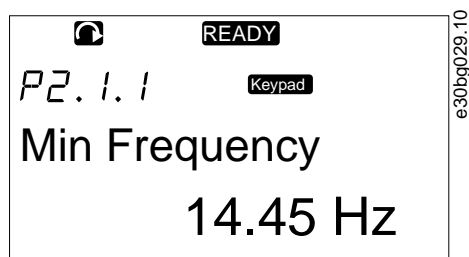

5. For locking the parameter values, use the *Parameter Lock* function in menu *M6*, see [8.7.6.6 Locking a Parameter](#).

## 8.4 Using the Keypad Control Menu

### 8.4.1 Finding the Keypad Control Menu

#### Context:

In the Keypad control menu, the following functions are available: selecting the control mode, editing the frequency reference, and changing the direction of the motor.

**Procedure**

1. To find the *Keypad control* menu, scroll down in the main menu until the location indication *M3* shows on the first line of the display.



2. To go to the *Keypad control* menu from the main menu, push the Menu button Right.

### 8.4.2 Keypad Control Parameters M3

Table 11: Keypad Control Parameters, M3

Index	Parameter	Min	Max	Unit	Default	Cust	ID	Description
P3.1	Control place	1	3		1		125	The control mode 1 = I/O terminal 2 = Keypad (control panel) 3 = Fieldbus
R3.2	Keypad reference	P2.1.1	P2.1.2	Hz	0.00		123	0 = Forward 1 = Reverse
P3.3	Direction (on keypad)	0	1		0			
P3.4	Stop button	0	1		1		114	0 = Limited function of Stop button 1 = Stop button always enabled

### 8.4.3 Changing the Control Mode

**Context:**

3 control modes are available to control the AC drive. For each control place, a different symbol shows on the display:

The control mode	The symbol
I/O terminals	I/O term
Keypad (control panel)	Keypad
Fieldbus	Bus/Comm

**Procedure**

1. In the *Keypad control* menu (M3), find the control mode (*Control Place*) with Menu buttons Up and Down.



2. To go to the edit mode, push the Menu button Right.
  - The parameter value starts to blink.
3. To scroll through the options, push the Browser buttons Up and Down.
4. To select the control mode, push the [enter] button.

## 8.4.4 Changing the Rotation Direction

**Context:**

The keypad direction submenu shows the rotation direction of the motor. In this submenu, also the rotation direction can be changed.

For more information on how to control the motor with the control panel, see [3.10.1 Keypad](#) and [9.2 Commissioning the Inverter](#).

**Procedure**

1. In the *Keypad control* menu (M3), find the Keypad direction with the Menu buttons Up and Down.
2. To go to the edit mode, push the Menu button Right.
3. Select the direction with Menu buttons Up and Down.
  - The rotation direction changes on the control panel.
4. To make the motor to agree with the set rotation direction, select the keypad as the control mode, see [8.4.3 Changing the Control Mode](#).

## 8.4.5 Disabling the Stop Motor Function

**Context:**

As a default, the motor stops when the Stop button is pushed no matter what is the control mode. Use these instructions to disable this function.

**Procedure**

1. In the *Keypad control* menu (M3), find the page 3.4. Stop button with the Browser buttons.
2. To go to the edit mode, push the Menu button Right.
3. To select Yes or No, use the Browser buttons.
4. Accept the selection with the [enter] button.
  - When the Stop motor function is not active, the Stop button stops the motor only when the keypad is the control mode.

## 8.4.6 Special Functions in Keypad Control Menu

### 8.4.6.1 Selecting the Keypad as the Control Mode

#### Context:

This is a special function only available in menu M3.

#### Prerequisites:

Make sure to be in the menu M3 and control mode is other than keypad.

#### Procedure

1. Do one of the following options:

Keep the Start button pushed down for 3 s when the motor is in RUN state.

Keep the Stop button pushed down for 3 s when the motor is stopped.

In other menu than M3, when the keypad is not the active control mode and the start button is pushed, an error message *Keypad Control NOT ACTIVE* shows. In some applications this error message is not shown.

- The keypad is selected as the control mode and the current frequency reference and direction is copied to the control panel.

### 8.4.6.2 Copying the Frequency Reference Set to the Control Panel

#### Context:

These are special functions only available in menu M3.

Use these instructions to copy the frequency reference set from I/O or fieldbus to control panel.

#### Prerequisites:

Make sure to be in menu M3 and that the control mode is other than keypad.

#### Procedure

1. Keep the [enter] button pushed down for 3 s.

In other menu than M3, when the keypad is not the active control mode and the start button is pushed, an error message *Keypad Control NOT ACTIVE* shows.

## 8.5 Using the Active Faults Menu (M4)

### 8.5.1 Finding the Active Faults Menu

#### Context:

The Active faults menu shows a list of active faults. When there are no active faults, the menu is empty.

For more information on the fault types and how to reset faults, see [11.1 General Information on Fault Tracing](#) and [11.2 Resetting a Fault](#). For the fault codes, possible causes and information on how to correct the fault, see the Faults and Alarms section.



**Procedure**

1. To find the *Active faults* menu, scroll down in the main menu until the location indication *M4* shows on the first line of the display.

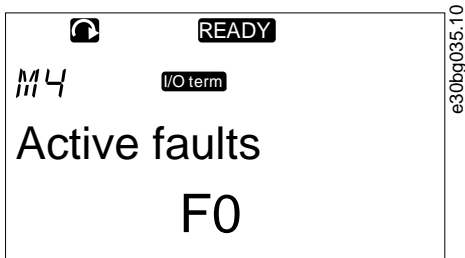

2. To go to the *Active faults* menu from the main menu, push the Menu button Right.

→ If there is a fault in the display, these symbols show:

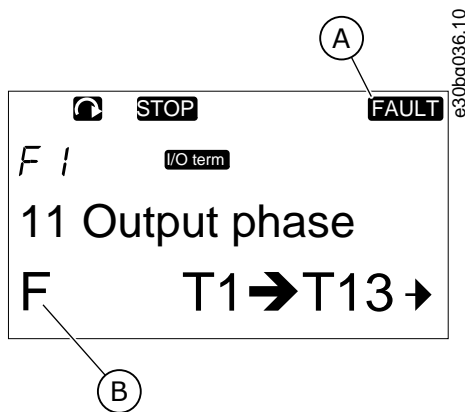

A Fault symbol	B Fault type symbol
----------------	---------------------

Illustration 35: Fault Symbols

## 8.5.2 Examining the Fault Time Data Record

**Context:**

This menu shows some important data that was valid at the time of the fault. This helps to find the cause of the fault.

**Procedure**

1. Find the fault in *Active faults* menu or *Fault history* menu.
2. Push the Menu button Right.
3. Scroll the data *T.1-T.16* with the Browser buttons.

## 8.5.3 Fault Time Data Record

The fault time data record shows some important data that was valid at the time of the fault. This helps to find the cause of the fault.

If real time is set on the AC drive, the data items *T1* and *T2* show as in column Real Time Data Record.

In some special cases, some of the fields can show other data than described in the table. If the value of a field differs significantly from the expected value, this special usage can be the reason. Contact the nearest distributor to get help from the factory in understanding the data.

Code	Description	Value	Real Time Data Record
T.1	Counted operation days	d	yyyy-mm-dd
T.2	Counted operation hours	hh:mm:ss (d)	hh:mm:ss,sss
T.3	Output frequency	Hz (hh:mm:ss)	
T.4	Motor current	A	
T.5	Motor voltage	V	
T.6	Motor power	%	
T.7	Motor torque	%	
T.8	DC voltage	V	
T.9	Unit temperature	°C	
T.10	Run status		
T.11	Direction		
T.12	Warnings		
T.13	0-speed <sup>(1)</sup>		
T.14	Subcode		
T.15	Module		
T.16	Submodule		

<sup>1</sup> Tells if the drive was at zero speed (< 0.01 Hz) when the fault showed.

## 8.6 Using the Fault History Menu (M5)

### 8.6.1 Fault History Menu (M5)

There is a maximum number of 30 faults in the Fault history. The information on each fault shows in the Fault time data record, see [8.5.3 Fault Time Data Record](#).

The value line of the main page (H1->H#) shows the number of faults in the fault history. The location indication tells in which order the faults have shown. The newest fault has the indication *H5.1*, the second newest *H5.2*, and so on. If there are 30 faults in the history, the next fault that shows removes the oldest one (*H5.30*) from the history.

See the different fault codes in the Faults and Alarms section.

## 8.6.2 Resetting the Fault History

### Context:

The Fault History shows 30 latest faults at a time. Use these instructions to reset the history.

#### Procedure

1. To find the *Fault history* menu, scroll down in the main menu until the location indication *M5* shows on the first line of the display.
2. To go to the *Fault history* menu from the main menu, push the Menu button Right.
3. In the *Fault history* menu, push the [enter] button for 3 s.
  - The symbol H# changes to 0.

## 8.7 Using the System Menu (M6)

### 8.7.1 Finding the System Menu

#### Context:

The System menu includes the general settings of the AC drive. These are, for example, application selection, parameter sets and information about the hardware and software. The number of submenus and subpages shows as the symbol S# (or P#) on the value line.

#### Procedure

1. To find the System menu, scroll down in the main menu until the location indication *M6* shows on the first line of the display.
2. To go to the System menu from the main menu, push the Menu button Right.

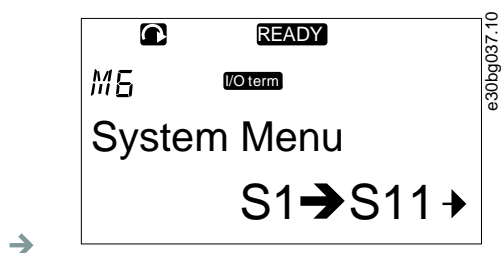

### 8.7.2 System Menu Functions

Table 12: System Menu Functions

Code	Function	Min	Max	Unit	Default	Cust	Description
S6.1	Language selection				English		The selection is different in all the language packages

Code	Function	Min	Max	Unit	Default	Cust	Description
S6.2	Application selection				Basic applica- tion		Basic application Standard application Local/Remote control appl. Multi-Step application PID Control application Multi-Purpose Control appl. Pump and Fan Control appl.
S6.3	Copy parameters						
S6.3.1	Parameter sets						Store set 1 Load set 1 Store set 2 Load set 2 Load factory defaults
S6.3.2	Load up to keypad						All parameters
S6.3.3	Load down from keypad						All parameters All but motor parameters Application parameters
P6.3.4	Parameter back-up				Yes		Yes No
S6.4	Compare parameters						
S6.4.1	Set1				Not used		
S6.4.2	Set 2				Not used		
S6.4.3	Factory settings						
S6.4.4	Keypad set						
S6.5	Security						
S6.5.1	Password				Not used		0 = Not used
P6.5.2	Parameter lock				Change Ena- bled		Change Enabled Change Disabled
S6.5.3	Start-up wizard						No Yes

Code	Function	Min	Max	Unit	Default	Cust	Description
S6.5.4	Multimonitoring items						Change Enabled Change Disabled
S6.6	Keypad settings						
P6.6.1	Default page						
P6.6.2	Default page/ Operating menu						
P6.6.3	Timeout time	0	65535	s	30		
P6.6.4	Contrast	0	31		18		
P6.6.5	Backlight time	Always	65535	min	10		
S6.7	Hardware settings						
P6.7.1	Internal brake resistor				Connected		Not connected Connected
P6.7.2	Fan control				Continuous		Continuous Temperature First start Calc temp
P6.7.3	HMI acknowledg. timeout	200	5000	ms	200		
P6.7.4	HMI number of retries	1	10		5		
P6.7.5	Sine filter				Connected		Not connected Connected
S6.8	System information						
S6.8.1	Total counters						
C6.8.1.1	MWh counter			kWh			
C6.8.1.2	Power On day counter						
C6.8.1.3	Power On hours counter			hh:mm:ss			
S6.8.2	Trip counters						
T6.8.2.1	MWh counter			kWh			
T6.8.2.2	Clear MWh trip counter						
T6.8.2.3	Operating days trip counter						
T6.8.2.4	Operating hours trip counter			hh:mm:ss			
T6.8.2.5	Clear operating time counter						
S6.8.3	Software info						
S6.8.3.1	Software package						
S6.8.3.2	System software version						

Code	Function	Min	Max	Unit	Default	Cust	Description
S6.8.3.4	System load						
S6.8.4	Applications						
S6.8.4.#	Name of application						
D6.8.4.#. 1	Application ID						
D6.8.4.#. 2	Applications: Version						
D6.8.4.#. 3	Applications: Firmware interface						
S6.8.5	Hardware						
I6.8.5.1	Info: Power unit type code						
I6.8.5.2	Info: Unit voltage			V			
I6.8.5.3	Info: Brake chopper						
I6.8.5.4	Info: Brake resistor						
S6.8.6	Expander boards						
S6.8.7	Debug menu						For Application programming only. Speak to the factory to get instructions.

### 8.7.3 Changing the Language

**Context:**

Use these instructions to change the language of the control panel. The possible languages are different in all language packages.

**Procedure**

1. In the *System* menu (M6), find the *Language* selection page (S6.1) with the Browser buttons.
2. To go to the edit mode, push the Menu button Right.
  - The name of the language starts to blink.
3. To select the language for the control panel texts, use the Menu buttons Up and Down.
4. To accept the selection, push the [enter] button.
  - The name of the languages stops to blink and all text information on the control panel shows in the selected language.

### 8.7.4 Changing the Application

**Context:**

The application can be changed in the *Application* selection page (S6.2). When the application is changed, all parameters are reset.

For more information on the Application Package, see VACON® NX All in One Application Manual.

**Procedure**

1. In the *System* menu (*M6*), find the *Application* selection page (*S6.2, Application*) with the *Browser* buttons.
2. Push the *Menu* button *Right*.
3. To go to the edit mode, push the *Menu* button *Right*.
  - The name of the application starts to blink.
4. Scroll through the applications with the *Browser* buttons and select a different application.
5. To accept the selection, push the *[enter]* button.
  - The AC drive starts again and goes through the set-up.
6. When the display shows the question *Copy parameters?*, there are 2 options:

This question shows only if the parameter *P6.3.4 Parameter back-up* is set to *Yes*.

- To upload the parameters of the new application to the control panel, select *Yes* with the *Browser* buttons.
- To keep the parameters of the application that was last used in the control panel, select *No* with the *Browser* buttons.

### 8.7.5 Copy Parameters (S6.3)

Use this function to copy parameters from one AC drive to a different AC drive or to save parameter sets in the internal memory of the AC drive.

Stop the AC drive before copying or downloading parameters.

#### 8.7.5.1 Saving Parameter Sets (Parameter Sets S6.3.1)

**Context:**

Use this function to get the factory default values back or save 1–2 customized parameter sets. A parameter set includes all parameters of the application.

**Procedure**

1. In the *Copy parameters* (*S6.3*) subpage, find the *Parameter sets* (*S6.3.1*) with the *Browser* buttons.
2. Push the *Menu* button *Right*.
3. To go to the edit mode, push the *Menu* button *Right*.
  - The text *LoadFactDef* starts to blink.
4. There are 5 options to select from. Select the function with the *Browser* buttons.
  - Select *LoadFactDef* to download again the factory default values.
  - Select *Store set 1* to save actual values of all parameters as set 1.
  - Select *Load set 1* to download the values in set 1 as the actual values.
  - Select *Store set 2* to save actual values of all parameters as set 2.
  - Select *Load set 2* to download the values in set 2 as the actual values.
5. To accept the selection, push the *[enter]* button.
6. Wait until *OK* shows on the display.

### 8.7.5.2 Uploading Parameters to Control Panel (Up To Keypad, S6.3.2)

#### Context:

Use this function to upload all parameter groups to the control panel when the AC drive is stopped.

#### Procedure

1. In the Copy parameters (S6.3) subpage, find the *Up to keypad* page (S6.3.2).
2. Push the Menu button Right.
3. To go to the edit mode, push the Menu button Right.
  - *All param.* starts to blink.
4. To accept the selection, push the [enter] button.
5. Wait until *OK* shows on the display.

### 8.7.5.3 Downloading Parameters to Drive (Down From Keypad, S6.3.3)

#### Context:

Use this function to download 1 or all parameter groups from the control panel to an AC drive when the AC drive is stopped.

#### Procedure

1. In the Copy parameters (S6.3) subpage, find the *Down from keypad* page (S6.3.3).
2. Push the Menu button Right.
3. To go to the edit mode, push the Menu button Right.
4. Use the Browser buttons to select 1 of these 3 options:

All parameters (*All param.*)

All parameters but the motor nominal value parameters (*All. no motor*)

Application parameters

5. To accept the selection, push the [enter] button.
6. Wait until *OK* shows on the display.

### 8.7.5.4 Activating or Deactivating the Automatic Parameter Back-up (P6.3.4)

#### Context:

Use these instructions to activate or deactivate the parameter back-up.

#### Prerequisites:

When the application is changed, the parameters in the parameter settings on page S6.3.1 are deleted. To copy parameters from one application to a different application, first upload them to the control panel.



**Procedure**

1. In the Copy parameters (S6.3) subpage, find the Automatic parameter back-up page (S6.3.4).
  2. To go to the edit mode, push the Menu button Right.
  3. There are 2 options:
    - To activate the Automatic parameter back-up, select Yes with the Browser buttons.
    - To deactivate the Automatic parameter back-up, select No with the Browser buttons.
- When the Automatic parameter back-up is active, the control panel makes a copy of the parameters of the application. Each time a parameter is changed, the keypad back-up is automatically updated.

### 8.7.5.5 Comparing the Parameters

**Context:**

Use the Parameter comparison submenu (S6.4, Param.Comparison) to compare the actual parameter values to the values of the customized parameter sets and those uploaded to the control panel. The actual values can be compared to Set 1, Set 2, Factory Settings, and Keypad Set.

**Procedure**

1. In the Copy parameters (S6.3) subpage, find the Comparing parameters submenu with the Browser buttons.
2. Push the Menu button Right.
  - The actual parameter values are first compared to those of the customized parameter Set 1. If no differences are found, 0 shows on the bottom line. If there are differences, the display shows the number of the differences (for example, P1->P5 = 5 different values).
3. To compare the values to a different set, use the Browser buttons.
4. To go to the page with the parameter values, push the Menu button Right.
  - In the display that opens, check the values on different lines:

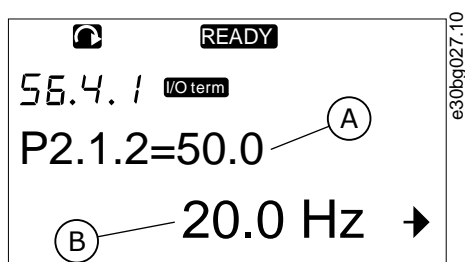

A Value of the selected set	B Actual value
-----------------------------	----------------

**Illustration 36: Parameter Values in Parameter Comparison**

5. To go to the edit mode, push the Menu button Right.
  - The actual value starts to blink.
6. To change the actual value, use the Browser buttons, or change the value digit by digit with the Menu button Right.

## 8.7.6 Security

### 8.7.6.1 Finding the Security Menu

#### Context:

The Security menu is password protected. Use it to handle passwords, start-up wizards, and multimonitoring items, and to lock parameters.

#### Procedure

1. To find the *Security* submenu, scroll down in the *System* menu until the location indication *S6.5* shows on the first line of the display.
2. To go to the *Security* submenu from the *System* menu, push the Menu button Right.

### 8.7.6.2 Passwords

To prevent unauthorized changes in the application selection, use the Password function (*S6.5.1*). By default, the password is not active.

#### NOTICE

Keep the password in a safe location!

### 8.7.6.3 Setting a Password

#### Context:

Set a password to protect the application selection menu.

#### NOTICE

Keep the password in a safe location! The password cannot be changed if a valid password is not available.

**Procedure**

1. In *Security* submenu, push the Menu button Right.
2. To go to the edit mode, push the Menu button Right.
  - The display shows 0 that blinks.
3. There are 2 options to set a password: with the Browser buttons or by digits. The password can be a number between 1 and 65535.
  - With the Browser buttons: Push the Browser buttons Up and Down to find a number.
  - By digits: Push the Menu button Right. A second 0 shows on the display.
    - Push the Browser buttons to set digit on the right.
    - Push the Menu button Left, and set the digit on the left.
    - To add a third digit, push the Menu button Left. Set up to 5 digits with Menu and Browser buttons and set the digit for each one with the Browser buttons.
4. To accept the new password, push the [enter] button.
  - The password activates after the Timeout time (P6.6.3) (see [8.7.7.4 Setting the Timeout Time](#)).

### 8.7.6.4 Entering a Password

**Context:**

In a password-protected submenu, the display shows *Password?* Use these instructions to enter the password.

**Procedure**

1. When the display shows *Password?*, give the password with the Browser buttons.

### 8.7.6.5 Deactivating the Password Function

**Context:**

Use these instructions to deactivate the password protection for application selection menu.

**Procedure**

1. Find the *Password (S6.5.1)* in the *Security* menu with the Browser buttons.
2. To go to the edit mode, push the Menu button Right.
3. Set value 0 for the password.

### 8.7.6.6 Locking a Parameter

**Context:**

Use the Parameter lock function to prevent changes to the parameters. If the parameter lock is active, the text *locked* shows on the display when trying to edit a parameter value.

**NOTICE**

This function does not prevent unauthorized changes of parameter values.

**Procedure**

1. In the *Security* menu (M6), find the Parameter lock (P6.5.2) with the Browser buttons.
2. To go to the edit mode, push the Menu button Right.
3. To change the parameter lock status, use the Browser buttons.
4. To accept the change, push the [enter] button.

### 8.7.6.7 Start-up Wizard (P6.5.3)

The start-up wizard helps in the commissioning of the AC drive. By default, the start-up wizard is active.

In the start-up wizard, this information is set:

- the language
- the application
- the values for a set of parameters that are same to all applications
- the values for a set of application-specific parameters.

The table lists the functions of the keypad buttons in the start-up wizard.

Action	Button
Accepting a value	[enter] button
Scrolling for options	Browser buttons Up and Down
Changing a value	Browser buttons Up and Down

### 8.7.6.8 Activating/Deactivating the Start-up Wizard

**Context:**

Use these instructions to activate or deactivate the Start-up Wizard function.

**Procedure**

1. In the *System* menu (M6), find the page P6.5.3.
2. To go to the edit mode, push the Menu button Right.
3. Select the action:
  - To activate the start-up wizard, select *Yes* with the Browser buttons.
  - To deactivate the start-up wizard, select *No* with the Browser buttons.
4. To accept the selection, push the [enter] button.

### 8.7.6.9 Enabling/Disabling the Change of Multimonitoring Items

**Context:**

Use Multimonitoring to monitor up to 3 actual values at the same time (see [8.2 Using the Monitoring Menu \(M1\)](#) and the chapter Monitored values in the Application Manual of your application).

Use these instructions to enable the change when changing the values that are monitored with other values.

#### Procedure

1. In the *Security* submenu, find Multimonitoring items page (P6.5.4, *Multimon. items*) with the Browser buttons.
2. To go to the edit mode, push the Menu button Right.  
→ *Change Enabled* starts to blink.
3. Use Browser buttons Up and Down to select *Change Enabled* or *Change Disabled*.
4. Accept the selection with the [enter] button.

## 8.7.7 Keypad Settings

### 8.7.7.1 Finding the Keypad Settings Menu

#### Context:

Use the Keypad settings submenu in the System menu for making changes in the control panel.

In the submenu, there are 5 pages (P#) that control the panel operation:

- *Default page* (P6.6.1)
- *Default page in the operating menu* (P6.6.2)
- *Timeout time* (P6.6.3)
- *Contrast adjustment* (P6.6.4)
- *Backlight time* (P6.6.5)

#### Procedure

1. In the *System* menu (M6), find the *Keypad settings* submenu (S6.6) with the Browser buttons.

### 8.7.7.2 Changing the Default Page

#### Context:

Use the Default page to set the location (page) to which the display automatically moves after the Timeout time or after the panel is set on.

For more information on the timeout time, see [8.7.7.4 Setting the Timeout Time](#).

If the Default Page value is 0, the function is not activated. When the Default page is not used, the control panel shows the page that was last showed on the display.

#### Procedure

1. In the *Keypad settings* submenu, find the *Default page* subpage (P6.6.1) with the Browser buttons.
2. To go to the edit mode, push the Menu button Right.
3. To change the number of the main menu, use the Browser buttons.
4. To edit the number of the submenu/page, push the Menu button Right. Change the number of the submenu/page with the Browser buttons.
5. To edit the third level page number, push the Menu button Right. Change the number of the third level page with the Browser buttons.
6. To accept the new default page value, push the [enter] button.

### 8.7.7.3 Default Page in the Operating Menu (P6.6.2)

Use this submenu to set the default page in the Operating menu. The display automatically moves to the set page after the Timeout time (see [8.7.7.4 Setting the Timeout Time](#)) or after the control panel is set on. For instructions, see [8.7.7.2 Changing the Default Page](#).

The Operating menu is only available in special applications.

### 8.7.7.4 Setting the Timeout Time

#### Context:

The Timeout time sets the time after which the control panel display goes back to the *Default page* (P6.6.1), see [8.7.7.2 Changing the Default Page](#).

If the Default page value is 0, the Timeout time setting has no effect.

#### Procedure

1. In the *Keypad settings* submenu, find the *Timeout time* subpage (P6.6.3) with the Browser buttons.
2. To go to the Edit mode, push the Menu button Right.
3. To set the timeout time, use the Browser buttons.
4. To accept the change, push the [enter] button.

### 8.7.7.5 Contrast Adjustment (P6.6.4)

If the display is not clear, adjust its contrast with the same procedure as the one for the timeout time setting, see [8.7.7.4 Setting the Timeout Time](#).

### 8.7.7.6 Backlight Time (P6.6.5)

It is possible to set the time that the backlight stays on until it goes off. Select a value between 1 and 65535 minutes or *Forever*. For instructions on how to change the value, see [8.7.7.4 Setting the Timeout Time](#).

## 8.7.8 Hardware Settings

### 8.7.8.1 Finding the Hardware Setting Menu

#### Context:

Use the Hardware settings submenu (*S6.7, HW settings*) in the *System* menu to control these functions of the hardware in the AC drive:

- Internal brake resistor connection, *InternBrakeRes*
- *Fan control*
- HMI acknowledge timeout, *HMI ACK timeout*
- *HMI retry*
- Sine filter
- Pre-charge mode.

#### Prerequisites:

Use a password to go the Hardware settings submenu, see [8.7.6.2 Passwords](#).

### Procedure

1. To find the Hardware settings submenu, scroll down in the *System* menu until the location indication *S6.7* shows on the first line of the display.
2. To go to the Hardware settings submenu from the *System* menu, push the Menu button Right.

## 8.7.8.2 Setting the Internal Brake Resistor Connection

### Context:

Use this function to tell the AC drive if the internal brake resistor is connected or not.

If the AC drive has an internal brake resistor, the default value of this parameter is *Connected*. We recommend changing this value to *Not conn.* if:

- it is necessary to install an external brake resistor to increase the braking capacity
- the internal brake resistor is disconnected for some reason.

### Prerequisites:

The brake resistor is available as optional equipment for all sizes. It can be installed internally in enclosure sizes FR4 to FR6.

### Procedure

1. In the Hardware settings submenu, find the Internal brake resistor connection (6.7.1) subpage with the Browser buttons.
2. To go to the edit mode, push the Menu button Right.
3. To change the internal brake resistor status, use the Browser buttons.
4. To accept the change, push the [enter] button.

## 8.7.8.3 Fan Control

Use this function to control the cooling fan of the AC drive. There are 4 options to select from:

- *Continuous* (default setting). The fan is always on when the power is on.
- *Temperature*. The fan starts automatically when the heat sink temperature goes to 60 °C (140 °F) or when the AC drive operates. The fan stops about a minute after one of the following:
  - the heat sink temperature falls to 55 °C (131 °F)
  - the AC drive stops
  - the fan control value is changed from *Continuous* to *Temperature*
- *First start*. When power is on, the fan is in the stop state. When the AC drive gets the first start command, the fan starts.
- *Calc temp*. The fan function agrees to the calculated IGBT temperature:
  - If the IGBT temperature is more than 40 °C (104 °F), the fan starts.
  - If the IGBT temperature is below 30 °C (86 °F), the fan stops.

As the default temperature at power-up is 25 °C (77 °F), the fan does not start immediately.

For instructions, see [8.7.8.4 Changing the Fan Control Settings](#).

### 8.7.8.4 Changing the Fan Control Settings

#### Context:

Use these instructions to change the Fan Control Settings.

#### Procedure

1. In the Hardware settings submenu, find the *Fan control* settings (6.7.2) with the Browser buttons.
2. To go to the edit mode, push the Menu button Right.
  - The parameter value starts to blink.
3. To select the fan mode, use the Browser buttons.
4. To accept the change, push the [enter] button.

### 8.7.8.5 HMI Acknowledge Timeout (P6.7.3)

Use this function to change the timeout of the HMI acknowledgement time. Use this function when there is more delay in the RS232 transmission, for example, when internet connection is used for communication over longer distances.

If the AC drive is connected to the PC with a cable, do not change the default values of parameters 6.7.3 and 6.7.4 (200 and 5).

If the AC drive is connected to the PC with an internet connection and the messages are transferred with a delay, set the values for parameter 6.7.3 to agree these delays.

For instructions, see [8.7.8.6 Changing the HMI Acknowledge Timeout](#).

#### Example:

For example, if the transfer delay between the AC drive and the PC is 600 ms, make these settings:

- Set the value of parameter 6.7.3 to 1200 ms (2 x 600, sending delay + receiving delay)
- Set the [Misc]-part of the file NCDrive.ini to agree with the settings:
  - Retries = 5
  - AckTimeOut = 1200
  - TimeOut = 6000

Do not use intervals shorter than the AckTimeOut-time in the NC-Drive monitoring.

### 8.7.8.6 Changing the HMI Acknowledge Timeout

#### Context:

Use these instructions to change the HMI Acknowledge Timeout.

#### Procedure

1. In the Hardware settings submenu, find the HMI acknowledgement time (*HMI ACK timeout*) with the Browser buttons.
2. To go to the edit mode, push the Menu button Right.
3. To change the acknowledgement time, use the Browser buttons.
4. To accept the change, push the [enter] button.



### 8.7.8.7 Changing the Number of Retries to Receive HMI Acknowledgement (P6.7.4)

**Context:**

Use this parameter to set the number of times the AC drive tries to receive acknowledgement if it does not receive it during the acknowledgement time (P6.7.3) or if the received acknowledgement is defective.

**Procedure**

1. In the Hardware settings submenu, find the Number of retries to receive HMI acknowledgement (P6.7.4) with the Browser buttons.
2. To go to the edit mode, push the Menu button Right. The value starts to blink.
3. To change the number of retries, use the Browser buttons.
4. To accept the change, push the [enter] button.

### 8.7.8.8 Sine Filter (P6.7.5)

When using an old motor or a motor that was not made to be used with an AC drive, it can be necessary to use a sine filter. A sine filter makes the sine form of the voltage better than a dU/dt filter.

If a sine filter is used in the AC drive, set this parameter to *Connected* to put it into operation.

### 8.7.8.9 Pre-charge Mode (P6.7.6)

For an FI9 or a larger inverter unit, select *Ext.ChSwitch* to control an external charge switch.

## 8.7.9 System Info

### 8.7.9.1 Finding the System Info Menu

**Context:**

The *System info* submenu (S6.8) contains information on the hardware, software, and operation of the AC drive.

**Procedure**

1. To find the *System info* submenu, scroll down in the *System* menu until the location indication S6.8 shows on the first line of the display.
2. To go to the *System info* submenu from the *System* menu, push the Menu button Right.

### 8.7.9.2 Total Counters (S6.8.1)

The *Total counters* page (S6.8.1) has information on the AC drive operation times. The counters show the total number of MWh, operation days, and operation hours. The Total counters cannot be reset.

The Power On time counter (days and hours) always counts, when the AC power is on. The counter does not count when control unit runs on +24 V only.

**Table 13: Total Counters**

Page	Counter	Example
C6.8.1.1.	MWh counter	

Page	Counter	Example
C6.8.1.2.	Power On day counter	Value on display is 1.013. The drive has operated for 1 year and 13 days.
C6.8.1.3	Power On hour counter	Value on display is 7:05:16. The drive has operated for 7 hours 5 minutes and 16 s.

### 8.7.9.3 Trip Counters (S6.8.2)

The *Trip counters* page (S6.8.2) has information on resettable counters, that is, counters, for which the value can be set back to 0. The trip counters count only when the motor is in RUN state.

Table 14: Trip Counters

Page	Counter	Example
T6.8.2.1	MWh counter	
T6.8.2.3	Operation day counter	Value on display is 1.013. The drive has operated for 1 year and 13 days.
T6.8.2.4	Operation hour counter	Value on display is 7:05:16. The drive has operated for 7 hours 5 minutes and 16 s.

### 8.7.9.4 Resetting the Trip Counters

**Context:**

Use these instructions to reset the trip counters.

**Procedure**

1. In the *System info* submenu, find the *Trip counters* page (6.8.2) with the Browser buttons.
2. To go to the Clear MWh counter page (6.8.2.2, *Clr MWh cntr*) or to the Clear Operation time counter page (6.8.2.5, *Clr Optime cntr*), use the Menu button Right.
3. To go to the edit mode, push the Menu button Right.
4. To select Reset, push Browser buttons Up and Down.
5. To accept the selection, push the [enter] button.
6. The display shows again *Not reset*.

### 8.7.9.5 Software (S6.8.3)

The Software information page includes information on the AC drive software.

Page	Content
6.8.3.1	Software package
6.8.3.2	System software version
6.8.3.3	Firmware interface
6.8.3.4	System load

### 8.7.9.6 Applications (S6.8.4)

The *Applications* submenu (S6.8.4) contains information on all applications on the AC drive.

Page	Content
6.8.4.#	Name of application
6.8.4.#.1	Application ID
6.8.4.#.2	Version
6.8.4.#.3	Firmware interface

### 8.7.9.7 Examining the Application Page

**Context:**

Use these instructions to examine the *Applications* pages.

**Procedure**

1. In the *System info* submenu, find the *Applications* page with the Browser buttons.
2. To go to the *Applications* page, push the Menu button Right.
3. To select the application, use the Browser buttons. There are as many pages as there are applications on the AC drive.
4. To go to the Information pages, use the Menu button Right.
5. To see the different pages, use the Browser buttons.

### 8.7.9.8 Hardware (S6.8.5)

The Hardware information page includes information on the AC drive hardware.

Page	Content
6.8.5.1	Power unit type code
6.8.5.2	Nominal voltage of the unit
6.8.5.3	Brake chopper
6.8.5.4	Brake resistor
6.8.5.5	Serial number

### 8.7.9.9 Checking the Status of an Option Board

**Context:**

The *Expander boards* pages give information about the basic and option boards connected to the control board. See [7.1 Control Unit Components](#) for more information on the boards.

For more information on the parameters of the option boards, see [8.8.1 Expander Board Menu](#).

**Procedure**

1. In the *System info* submenu, find the *Expander boards* page (6.8.6) with the Browser buttons.
2. To go to the *Expander boards* page, push the Menu button Right.
3. To select the board, use the Browser buttons.
  - If no board is connected to the slot, the display shows *no board*.

If a board is connected to a slot but there is no connection, the display shows *no conn..*

4. To see the status of the board, push the Menu button Right.
5. To see the program version of the board, push the Browser button Up or Down.

### 8.7.9.10 Debug Menu (S6.8.7)

The Debug menu is for advanced users and application designers. Speak to the factory to get instructions, if it is necessary.

## 8.8 Using the Expander Board Menu

### 8.8.1 Expander Board Menu

The *Expander board* menu, that is, the menu for option board information, allows to:

- see which option boards are connected to the control board
- find and edit the option board parameters.

**Table 15: Option Board Parameters (Board OPTA1)**

Page	Parameter	Min	Max	Default	Cust	Selections
P7.1.1.1	AI1 mode	1	5	3		1 = 0–20 mA 2 = 4–20 mA 3 = 0–10 V 4 = 2–10 V 5 = –10...+10 V
P7.1.1.2	AI2 mode	1	5	1		See P7.1.1.1
P7.1.1.3	AO1 mode	1	4	1		1 = 0–20 mA 2 = 4–20 mA 3 = 0–10 V 4 = 2–10 V

### 8.8.2 Examining the Connected Option Boards

**Context:**

Use these instructions to examine the connected option boards.

**Procedure**

1. To find the *Expander board* menu, scroll down in the main menu until the location indication *M7* shows on the first line of the display.
2. To go to the *Expander board* menu from the main menu, push the Menu button Right.
3. To examine the list of connected option boards, use the Browser buttons Up and Down.
4. To see the information on the option board, push the Menu button Right.

### 8.8.3 Finding the Option Board Parameters

**Context:**

Use these instructions to check the values of the option board parameters.

**Procedure**

1. Find the option board with the Browser and Menu buttons in the *Expander Board Menu*.
2. To see the information on the option board, push the Menu button Right. For instructions on how to examine the connected option boards, see [8.8.2 Examining the Connected Option Boards](#).
3. To scroll to the Parameters use the Browser buttons Up and Down.
4. To examine the parameter list, push the Menu button Right.
5. To scroll through the parameters, use the Browser buttons Up and Down.
6. To go to the edit mode, push the Menu button Right. For instructions on how to edit the parameter values, see [8.3.2 Selecting Values](#) and [8.3.3 Editing the Values Digit by Digit](#).

## 8.9 Further Control Panel Functions

The VACON® NX control panel has more application-related functions. See VACON NX Application Package for more information.

## 9 Commissioning

### 9.1 Safety Checks before Starting the Commissioning

Before starting the commissioning, read these warnings.

#### ⚠ DANGER ⚠

##### SHOCK HAZARD FROM INVERTER POWER UNIT COMPONENTS

The inverter power unit components are live when the inverter is connected to DC supply. A contact with this voltage can lead to death or serious injury.

- Do not touch the components of the power unit when the inverter is connected to DC supply. Before connecting the inverter to DC supply, make sure that the covers of the inverter are closed.

#### ⚠ DANGER ⚠

##### SHOCK HAZARD FROM INVERTER TERMINALS

The motor terminals U, V, W, the brake resistor terminals, or the DC terminals are live when the inverter is connected to DC supply, also when the motor does not operate. A contact with this voltage can lead to death or serious injury.

- Do not touch the motor terminals U, V, W, the brake resistor terminals, or the DC terminals when the inverter is connected to DC supply. Before connecting the inverter to DC supply, make sure that the covers of the inverter are closed.

#### ⚠ DANGER ⚠

##### SHOCK HAZARD FROM DC LINK OR EXTERNAL SOURCE

The terminal connections and the components of the drive can be live 5 minutes after the inverter is disconnected from the DC supply and the motor has stopped. Also the load side of the inverter can generate voltage. A contact with this voltage can lead to death or serious injury.

- Before doing electrical work on the inverter:
  - Disconnect the inverter from the DC supply and make sure that the motor has stopped.
  - Lock out and tag out the power source to the inverter.
  - Make sure that no external source generates unintended voltage during work.
  - Wait 5 minutes before opening the cabinet door or the cover of the inverter.
  - Use a measuring device to make sure that there is no voltage.

#### ⚠ WARNING ⚠

##### SHOCK HAZARD FROM INVERTER CONTROL TERMINALS

The control terminals can have a dangerous voltage also when the drive is disconnected from DC supply. A contact with this voltage can lead to injury.

- Make sure that there is no voltage in the control terminals before touching the control terminals.

**⚠ CAUTION ⚠****BURNING HAZARD FROM HOT SURFACES**

The surface of the side of the AC drive FR8/FI8 is hot.

- Do not touch the side of the AC drive FR8/FI8 with hands when it operates.

**⚠ CAUTION ⚠****FIRE HAZARD FROM HOT SURFACES**

When the AC drive FR6/FI6 operates, the rear surface of the drive is hot, and can cause fire on the surface it is installed on.

- Do not install the AC drive FR6/FI6 on a surface that is not fireproof.

## 9.2 Commissioning the Inverter

**Context:**

Follow these instructions to commission the inverter.

**Prerequisites:**

Read the safety instructions in [2.2 Danger and Warnings](#) and [9.1 Safety Checks before Starting the Commissioning](#), and obey them.

### Procedure

1. Make sure that the motor is installed correctly.
2. Make sure that the motor is not connected to mains.
3. Make sure that the inverter and the motor are grounded.
4. Make sure to select the DC supply cable, the brake cable, and the motor cable correctly.

For information on cable selections, see:

- [6.1.3 Cable Selection and Dimensioning](#), [6.1.4 Cable Selection and Dimensioning, North America](#) and related tables
- [6.1 Cable Connections](#)
- [6.3 EMC-compliant Installation](#)

5. Make sure that the control cables are as far as possible from the power cables. See [6.5.1 Additional Instructions for Cable Installation](#)
6. Make sure that the shields of the shielded cables are connected to a grounding terminal that is identified with the grounding symbol.
7. Do a check of the tightening torques of all the terminals.
8. Make sure that no power correction capacitors are connected to the motor cable.
9. Make sure that the cables do not touch the electrical components of the inverter.
10. Make sure that the common input +24 V is connected to an external power source and the ground of the digital input is connected to ground of the control terminal.
11. Do a check of the quality and quantity of the cooling air.

For further information on cooling requirements, see:

- [5.2.1 General Cooling Requirements](#)
- [5.2.2 Cooling of FI4 to FI8](#)
- [12.8 Technical Data](#)

12. Make sure that there is no condensation on the surfaces of the inverter.
13. Make sure that there are no unwanted objects in the installation space.
14. Before connecting the inverter to DC supply, do a check of the installation and the condition of all the fuses (see [12.3 Cable and Fuse Sizes](#)) and other protective devices.

## 9.3 Measuring the Cable and Motor Insulation

Do these checks if necessary.

- The insulation checks of the motor cable, see [9.3.1 Insulation Checks of the Motor Cable](#)
- The insulation checks of the DC supply cable, see [9.3.2 Insulation Checks of the DC Supply Cable](#)
- The insulation checks of the motor, see [9.3.3 Insulation Checks of the Motor](#)

### 9.3.1 Insulation Checks of the Motor Cable

#### Context:

Use these instructions to check the insulation of the motor cable.



**Procedure**

1. Disconnect the motor cable from the terminals U, V, and W and from the motor.
2. Measure the insulation resistance of the motor cable between phase conductors 1 and 2, between phase conductors 1 and 3, and between phase conductors 2 and 3.
3. Measure the insulation resistance between each phase conductor and the grounding conductor.
4. The insulation resistance must be  $>1\text{ M}\Omega$  at the ambient temperature of  $20\text{ }^{\circ}\text{C}$  ( $68\text{ }^{\circ}\text{F}$ ).

### 9.3.2 Insulation Checks of the DC Supply Cable

**Context:**

Use these instructions to check the insulation of the DC supply cable.

**Procedure**

1. Disconnect the DC supply cable from terminals B- and B+ of the inverter and from DC supply.
2. Measure the insulation resistance between each phase conductor and the grounding conductor.
3. The insulation resistance must be  $>1\text{ M}\Omega$  at the ambient temperature of  $20\text{ }^{\circ}\text{C}$  ( $68\text{ }^{\circ}\text{F}$ ).

### 9.3.3 Insulation Checks of the Motor

**Context:**

Use these instructions to check the insulation of the motor.

**NOTICE**

Obey the instructions of the motor manufacturer.

**Procedure**

1. Disconnect the motor cable from the motor.
2. Open the bridging connections in the motor connection box.
3. Measure the insulation resistance of each motor winding. The voltage must be the same or higher than the motor nominal voltage, but at least  $1000\text{ V}$ .
4. The insulation resistance must be  $>1\text{ M}\Omega$  at the ambient temperature of  $20\text{ }^{\circ}\text{C}$  ( $68\text{ }^{\circ}\text{F}$ ).
5. Connect the motor cables to the motor.
6. Do the final insulation check on the drive side. Put all phases together and measure to the ground.
7. Connect the motor cables to the drive.

## 9.4 Checks after Commissioning

### 9.4.1 Testing the Inverter after Commissioning

**Context:**

Before starting the motor, do these checks.

**Prerequisites:**

- Before the tests, make sure that it is safe to do each test.
- Make sure that the other workers near know about the tests.

**Procedure**

1. Make sure that all the START and STOP switches that are connected to the control terminals are in the STOP position.
2. Make sure that the motor can be started safely.
3. Set the parameters of group 1 (see VACON® All in One Application Manual) to agree with the requirements of the used application. To find the necessary values for the parameters, see the motor nameplate.

Set these parameters at a minimum:

- Motor nominal voltage
  - Motor nominal frequency
  - Motor nominal speed
  - Motor nominal current
4. Set the maximum frequency reference (that is, the maximum speed of the motor) to agree with the motor and the device that is connected to the motor.
  5. Do the following tests in this order:
    - A RUN test without the load, see [9.4.2 RUN Test without Load](#)
    - B Start-up test, see [9.4.3 Start-up Test](#)

## 9.4.2 RUN Test without Load

Do either Test A or Test B.

- Test A: Controls from the control terminals
- Test B: Control from the control panel

## 9.4.3 Start-up Test

**Context:**

Do the start-up tests without the load, if possible. If it is not possible, make sure that it is safe to do each test before doing it. Make sure that the other workers near know about the tests.

**Procedure**

1. Switch off the DC supply voltage and wait until the inverter has stopped as advised in [9.1 Safety Checks before Starting the Commissioning](#).
2. Connect the motor cable to the motor and to the motor terminals of the inverter.
3. Make sure that all Start/Stop switches are in Stop positions.
4. Turn the supply voltage switch ON.
5. Do again the Run test A or B, see [9.4.2 RUN Test without Load](#).
6. If the motor was not connected in the start-up test, connect the motor to the process.
7. Do again the Run test A or B, see [9.4.2 RUN Test without Load](#).

## 9.4.4 Motor Run Checklist

### Context:

Do these checks before starting the motor.

### Procedure

1. Check that the motor is mounted properly and ensure that the machine connected to the motor allows the motor to be started.
2. Set the maximum frequency reference (that is, the maximum speed of the motor) according to the motor and the device that is connected to the motor.
3. Before reversing the motor, make sure it can be done safely.
4. Make sure that no power correction capacitors are connected to the motor cable.
5. Make sure that the motor terminals are not connected mains potential.

## 10 Maintenance

### 10.1 Maintenance Schedule

In normal conditions, VACON® NX Inverters are maintenance-free. To maintain trouble-free operation of the unit, environmental conditions, load, line power, and process control must be within specifications, determined by the manufacturer.

To make sure that the inverter operates correctly and has a long life, we recommend doing regular maintenance. Refer to the table for maintenance intervals.

We also recommend recording all actions and counter values with dates and time to follow up of maintenance.

Table 16: Maintenance Intervals and Tasks

Maintenance interval	Maintenance task
12 months <sup>(1)</sup>	<p>Reform the capacitors (see <a href="#">10.2 Reforming the Capacitors</a>)</p> <p>If the unit was in store for much longer than 12 months and the capacitors were not charged, speak to the factory to get instructions before connecting the power.</p>
6–24 months <sup>(2)</sup>	<ul style="list-style-type: none"> <li>• Do a check of the tightening torques of the terminals.</li> <li>• Clean the heat sink.</li> <li>• Clean the cooling channel.</li> <li>• Make sure that the cooling fan operates correctly.</li> <li>• Make sure that there is no corrosion on the terminals, the busbars, or other surfaces.</li> <li>• If there is cabinet installation, do a check of the door filters.</li> </ul>
5–7 years	<p>Change the cooling fans:</p> <ul style="list-style-type: none"> <li>• the main fan</li> <li>• the fan of the LCL filter</li> <li>• the internal IP54 (UL Type 12) fan</li> <li>• the cabinet cooling fan/filter</li> </ul>
5–10 years	<p>Change the DC bus capacitors, if the DC voltage ripple is high.</p>

<sup>1</sup> If the unit is kept in store.

<sup>2</sup> The interval is different in different environments.

### 10.2 Reforming the Capacitors

#### Context:

The electrolytic capacitors in the DC link rely on a chemical process to provide the insulator between the two metal plates. This process can degrade over a period of years when the drive has been non-operational (stocked). The result is that the working voltage of the DC link gradually falls.

The correct course of action is to ensure that the insulation layer of the capacitor is ‘reformed’ by the application of a limited current using a DC supply. Current limiting ensures that the heat generated within the capacitor is kept at a sufficiently low level to prevent any damage.

**⚠ DANGER ⚠**

**SHOCK HAZARD FROM CAPACITORS**

The capacitors can be charged even when disconnected. Contact with this voltage can lead to death or serious injury.

- If the AC drive or spare capacitors are intended to be stocked, discharge the capacitors before storage. Use a measuring device to make sure that there is no voltage. If in doubt, contact your Danfoss Drives® representative.

**Case 1: AC drive which has been non-operational or stocked for over 2 years.**

1. Connect the DC supply to LI1 and L2 or the B+/B terminals (DC+ to B+, DC- to B-) of the DC-link or directly to the capacitor terminals. In the NX AC drives with no B+/B- terminals (FR8-FR9/FI8-FI9), connect the DC supply between 2 input phases (L1 and L2).
2. Set the current limit maximum to 800 mA.
3. Slowly increase the DC voltage to the nominal DC voltage level of the AC drive ( $1.35 \cdot U_n$  AC).
4. Start to reform the capacitors.

The time of reforming depends on the time of storage. See [illustration 37](#).

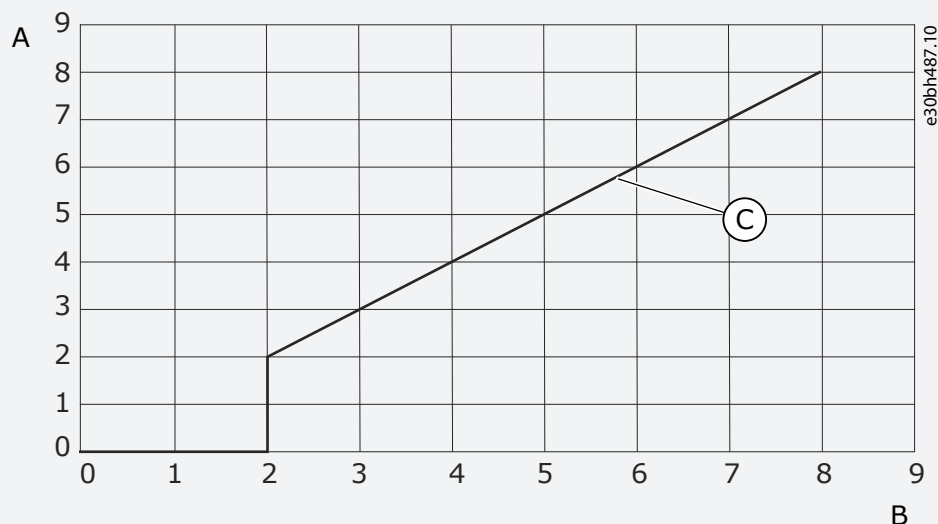

A Storage time (years)	B Reforming time (hours)
C Reforming time	

**Illustration 37: Storage Time and Reforming Time**

5. After the reforming operation is done, discharge the capacitors.

**Case 2: Spare capacitor which has been stocked for over 2 years.**

1. Connect the DC supply to DC+/DC- terminals.
2. Set the current limit maximum to 800 mA.
3. Slowly increase the DC voltage to the capacitor nominal voltage level. See information from component or service documentation.
4. Start to reform the capacitors.

The time of reforming depends on the time of storage. See [illustration 37](#).

5. After the reforming operation is done, discharge the capacitors.

## 11 Fault Tracing

### 11.1 General Information on Fault Tracing

When the control diagnostics of the AC drive find an unusual condition in the operation of the drive, the drive shows this information:

- This information shows on the display (see [8.5.1 Finding the Active Faults Menu](#)):
  - the location indication F1
  - the fault code, see the Faults and Alarms section
  - a short description of the fault
  - the fault type symbol, see [table 17](#)
  - the *FAULT* or *ALARM* symbol
- The red LED on the control panel starts to blink (only when a fault shows).

If many faults show at the same time, examine the list of active faults with the Browser buttons.

In the VACON® NX AC drives, there are 4 different types of faults.

Table 17: Fault Types

Fault type symbol	Description
A (Alarm)	The type A fault (Alarm) tells about unusual operation on the drive. It does not stop the drive. The 'A fault' stays in the display for about 30 s.
F (Fault)	The type 'F fault' stops the drive. To start the drive again, find a solution to the problem.
AR (Fault Autore-set)	The type 'AR fault' stops the drive. The fault is reset automatically and the drive tries to start the motor again. If it cannot the start the motor again, a fault trip (see FT, Fault Trip) shows.
FT (Fault Trip)	If the drive cannot start the motor after an AR fault, an FT fault shows. The type 'FT fault' stops the AC drive.

The fault stays active until it is reset, see [11.2 Resetting a Fault](#). The memory of active faults can keep the maximum of 10 faults in the order in which they were shown.

Reset the fault with the [reset] button on the control panel, or through the control terminal, fieldbus, or the PC tool. The faults stay in the Fault history.

Before asking help from the distributor or the factory because of unusual operation, prepare some data. Write down all the texts on the display, the fault code, the source information, the Active Faults list, and the Fault History.

### 11.2 Resetting a Fault

#### Context:

The fault stays active until it is reset. Reset the fault using these instructions.

**Procedure**

1. Remove the external Start signal before resetting the fault to prevent that the drive starts again without a note.
2. There are 2 options to reset a fault:
  - Push the [reset] button on the control panel for 2 s.
  - Use a reset signal from the I/O terminal or fieldbus.
    - The display goes back to the same state it was before the fault.

### 11.3 Creating Service Info File

**Context:**

Use these instructions to create a service info file in VACON® NCDrive PC tool to help to troubleshoot in a fault situation.

**Prerequisites:**

Make sure the VACON® NCDrive PC tool is installed on the computer. To install it, go to our website <http://drives.danfoss.com/downloads/portal/>.

**Procedure**

1. Open the VACON® NCDrive.
2. Go to *File* and select *Service Info...*
  - The service information file opens.
3. Save the service info file on the computer.

## 12 Specifications

### 12.1 Weights of the Inverter

Enclosure size	Weight, IP21/IP54 [kg]	Weight, UL Type 1/Type 12 [lb.]
FI4	5.0	11.0
FI6	16	32.3
FI7	29.0	63.9
FI8	48.0	105.8

### 12.2 Dimensions

For dimension information, see the following topics:

- [12.2.1 Dimensions for FI4–FI8](#)
- [12.2.2 Dimensions for Flange Mounting, FI4–FI6](#)
- [12.2.3 Dimensions for Flange Mounting, FI7–FI8](#)



12.2.1 Dimensions for FI4–FI8

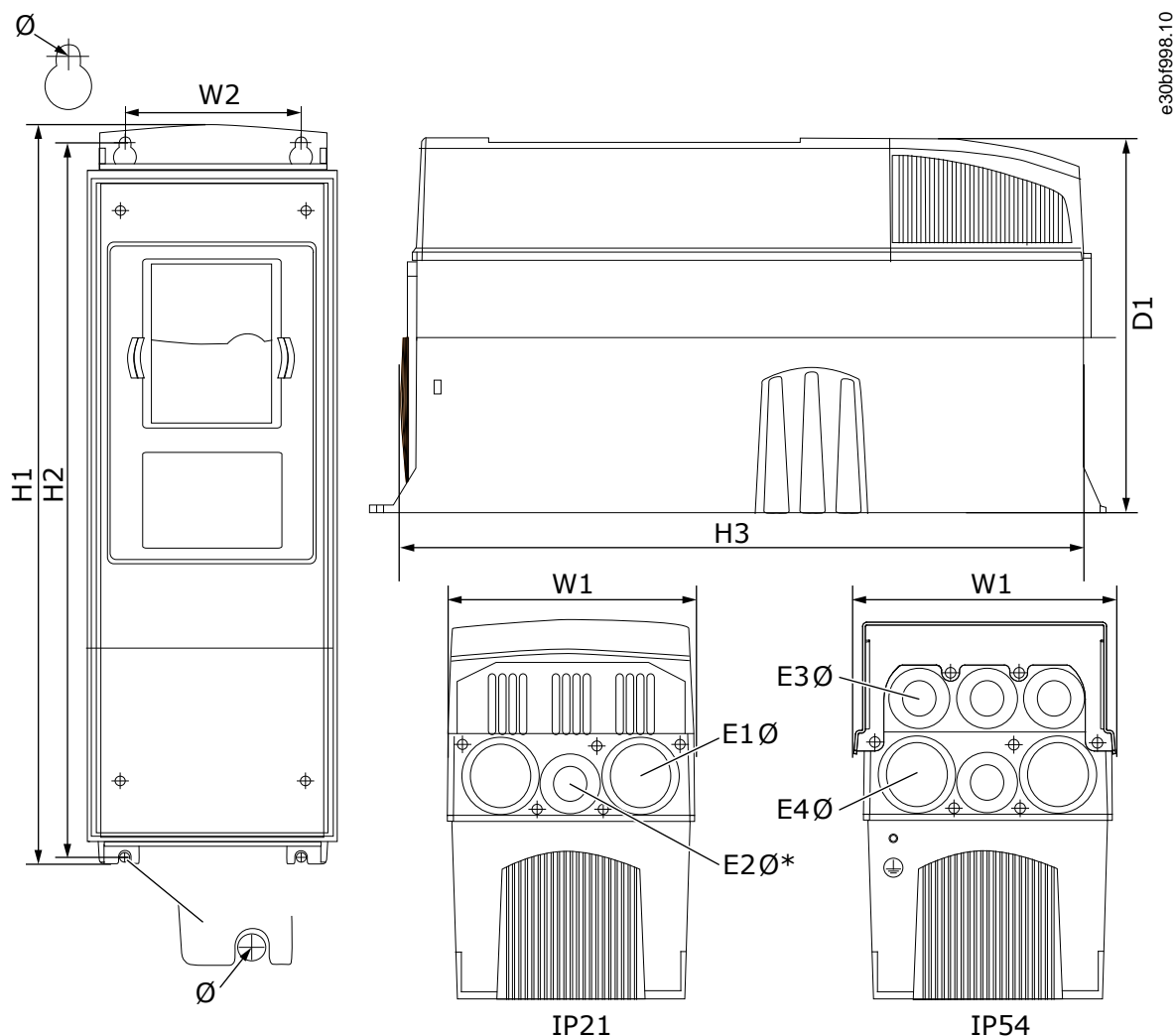

Illustration 38: Dimensions of the VACON® NX Inverters, FI4–FI8

Table 18: Dimensions in mm (in inch) of the VACON® NX Inverters, FI4–FI8

Drive type	W1	W2	H1	H2	H3	D1	Ø	E1Ø	E3Ø	E4Ø <sup>(1)</sup>
0004 2–0012 5	128 (5.04)	100 (3.94)	327 (12.87)	313 (12.32)	292 (11.5)	190 (7.48)	7 (0.27)	3 x 28.3 (3 x 1.11)	6 x 28.3 (6 x 1.11)	– (–)
0016 5–0045 5	195 (7.68)	148 (5.83)	558 (21.97)	541 (21.3)	519 (20.43)	237 (9.33)	9 (0.35)	3 x 37 (3 x 1.46)	3 x 37 (3 x 1.46)	3 x 28.3 (3 x 1.11)
0004 6–0034 6	237 (9.33)	190 (7.48)	630 (24.80)	614 (24.17)	591 (23.27)	237 (9.33)	9 (0.35)	3 x 37 (3 x 1.46)	3 x 37 (3 x 1.46)	3 x 28.3 (3 x 1.11)
0061 5–0105 5	237 (9.33)	190 (7.48)	630 (24.80)	614 (24.17)	591 (23.27)	237 (9.33)	9 (0.35)	3 x 37 (3 x 1.46)	3 x 37 (3 x 1.46)	3 x 28.3 (3 x 1.11)

Drive type	W1	W2	H1	H2	H3	D1	Ø	E1Ø	E3Ø	E4Ø <sup>(1)</sup>
0140 5	285	255	755	732	721	312	9	3 x 59		
0062 6-0100 6	(11.22)	(10.04)	(29.72)	(28.81)	(28.39)	(12.28)	(0.35)	(3 x)		

<sup>1</sup> FI6 only

### 12.2.2 Dimensions for Flange Mounting, FI4-FI6

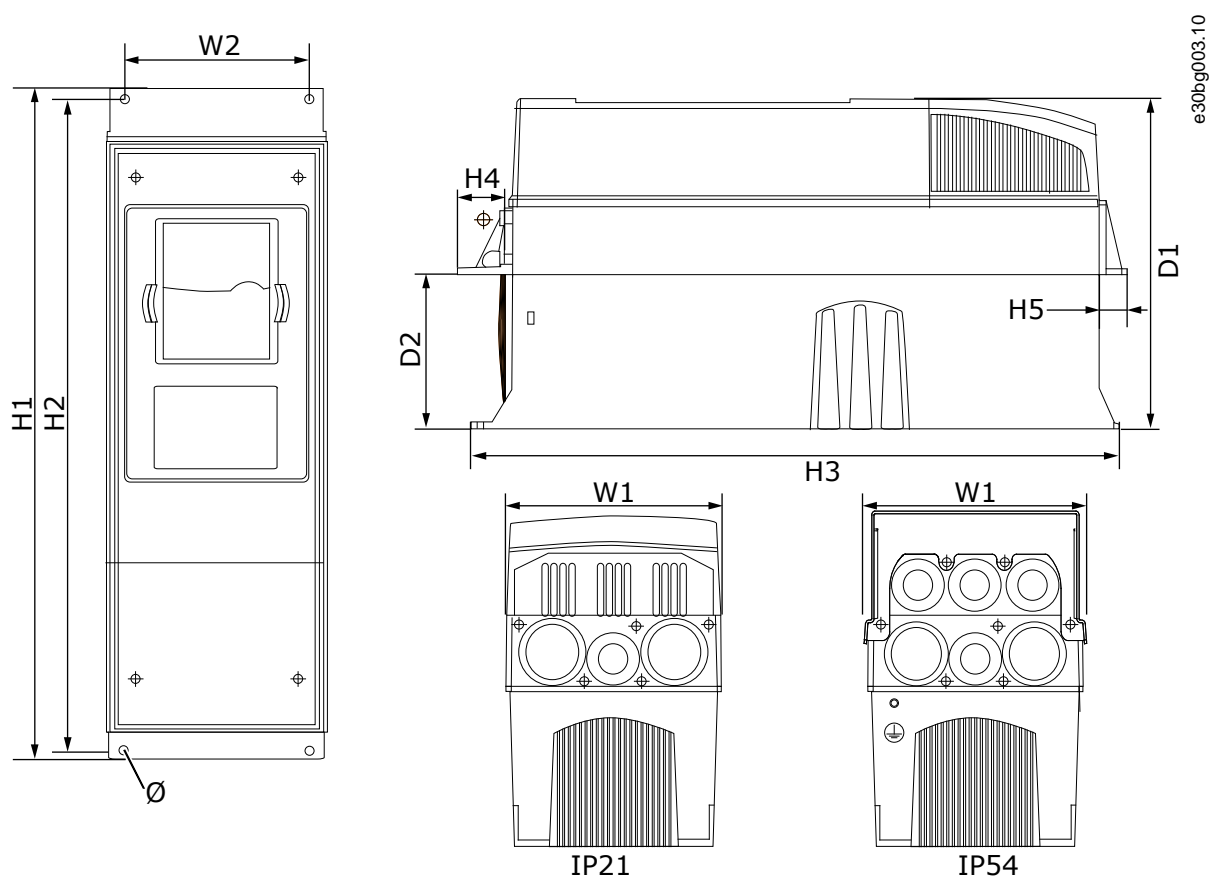

Illustration 39: Dimensions of the VACON® NX Inverters with Flange, FI4-FI6

Table 19: Dimensions in mm (in inch) of the VACON® NX Inverters with Flange, FI4-FI6

Drive type	W1	W2	H1	H2	H3	H4	H5	D1	D2	Ø
0004 5-0012 5	128	113	337	325	327	30	22	190	77	7
	(5.03)	(4.45)	(13.27)	(12.8)	(12.9)	(1.18)	(0.87)	(7.48)	(3.03)	(0.27)
0016 5-0045 5	195	170	560	549	558	30	20	237	106	6.5
0004 6-0034 6	(7.68)	(6.69)	(22.05)	(21.61)	(22)	(1.18)	(0.79)	(9.33)	(4.17)	(0.26)

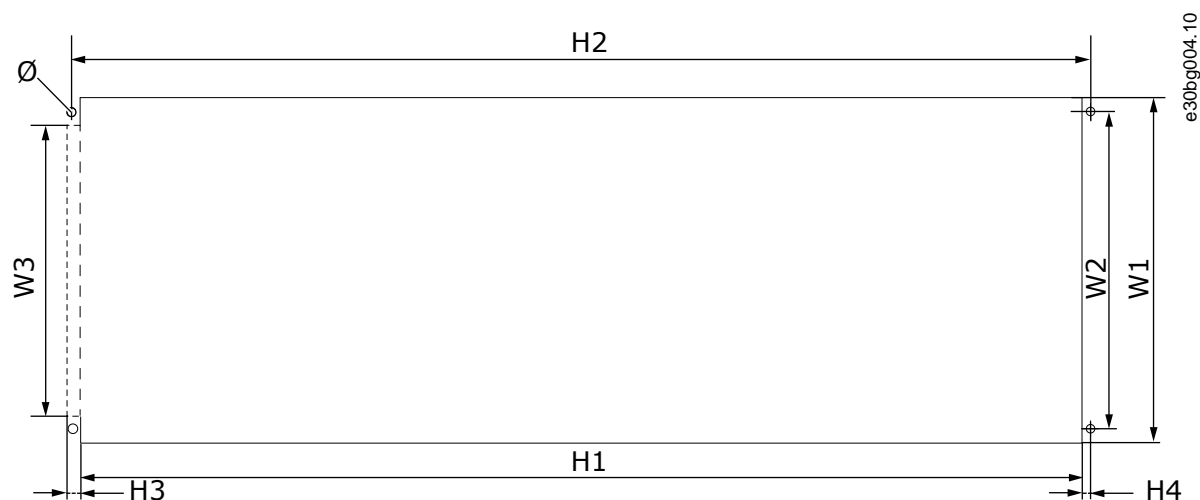

Illustration 40: The Dimensions of the Opening and Drive Outline with Flange, FI4 to FI6

Table 20: The Dimensions in mm (in inch) of the Opening and Drive Outline with Flange, FI4 to FI6

Drive type	W1	W2	W3	H1	H2	H3	H4	Ø
0004 5-0012 5	123 (4.84)	113 (4.45)	- (-)	315 (12.40)	325 (12.8)	- (-)	5 (0.20)	6.5 (0.26)
0016 5-0045 5	185	170	157	539	549	7	5	6.5
0004 6-0034 6	(7.28)	(6.69)	(6.18)	(21.22)	(21.61)	(0.27)	(0.20)	(0.26)

12.2.3 Dimensions for Flange Mounting, FI7–FI8

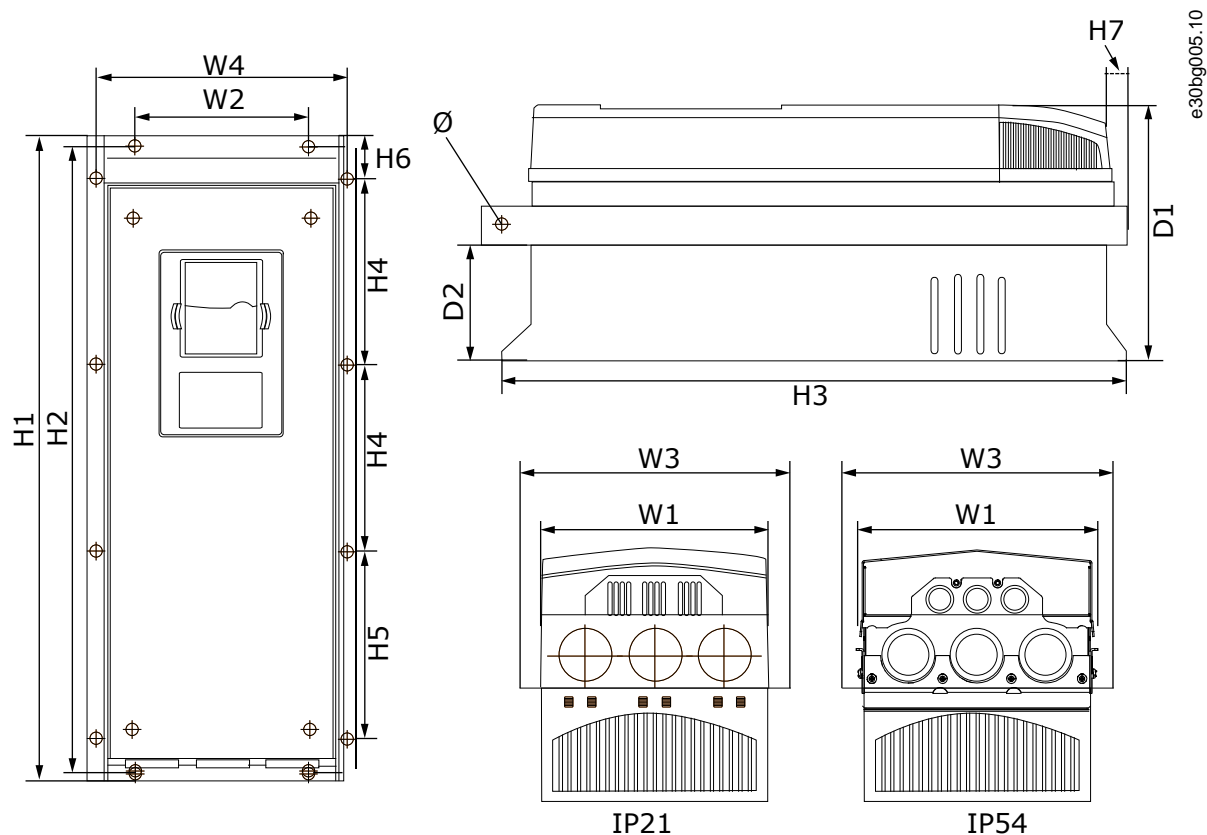

Illustration 41: Dimensions of the VACON® NX Inverters with Flange, FI7 and FI8

Table 21: Dimensions in mm (in inch) of the VACON® NX Inverters with Flange, FI7 and FI8, part 1

Drive type	W1	W2	W3	W4	D1	D2	Ø
0061 5–0105 5	237	175	270	253	257	117	5.5
0041 6–0052 6	(9.33)	(6.89)	(10.63)	(9.96)	(10.12)	(4.61)	(0.22)
0140 5	285	–	355	330	288	110	9
0062 6–0100 6	(29.72)	(–)	(13.98)	(12.99)	(11.34)	(4.33)	(0.35)

Table 22: Dimensions in mm (in inch) of the VACON® NX Inverters, FI7 and FI8, part 2

Drive type	H1	H2	H3	H4	H5	H6	H7
0061 5–0105 5	652	632	630	188.5	188.5	23	20
0041 6–0052 6	(25.67)	(24.88)	(24.80)	(7.42)	(7.42)	(0.91)	(0.79)
0140 5	755	–	745	258	265	43	57
0062 6–0100 6	(29.72)	(–)	(29.33)	(10.16)	(10.43)	(1.69)	(2.24)

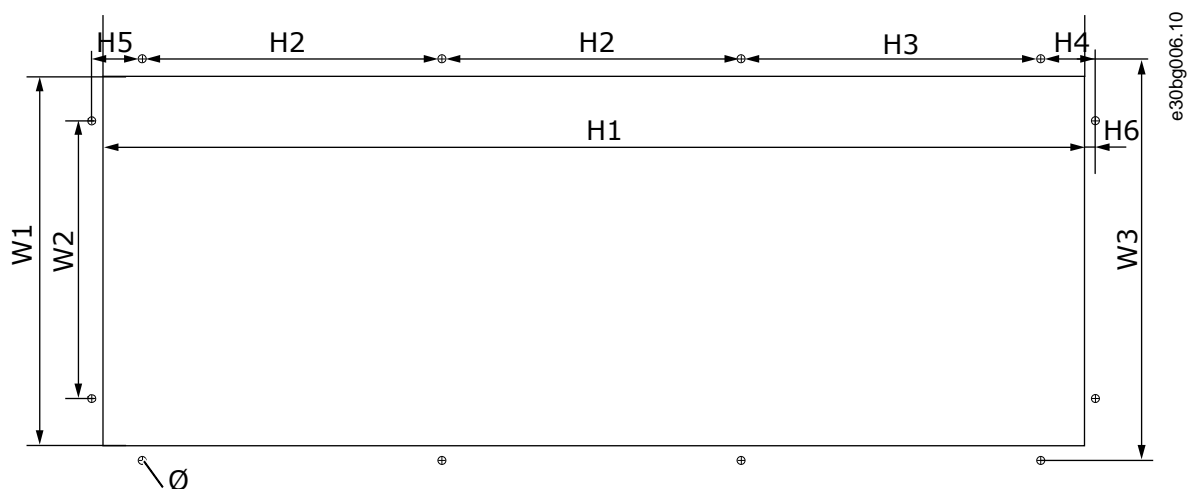

Illustration 42: Dimensions of the Opening and Drive Outline with Flange, FI7

Table 23: Dimensions in mm (in inch) of the Opening and Drive Outline with Flange, FI7

Drive type	W1	W2	W3	H1	H2	H3	H4	H5	H6	Ø
0061 5-0105 5	233	175	253	619	188.5	188.5	34.5	32	7	5.5
0041 6-0052 6	(9.17)	(6.89)	(9.96)	(24.4)	(7.42)	(7.42)	(1.36)	(1.26)	(0.28)	(0.22)

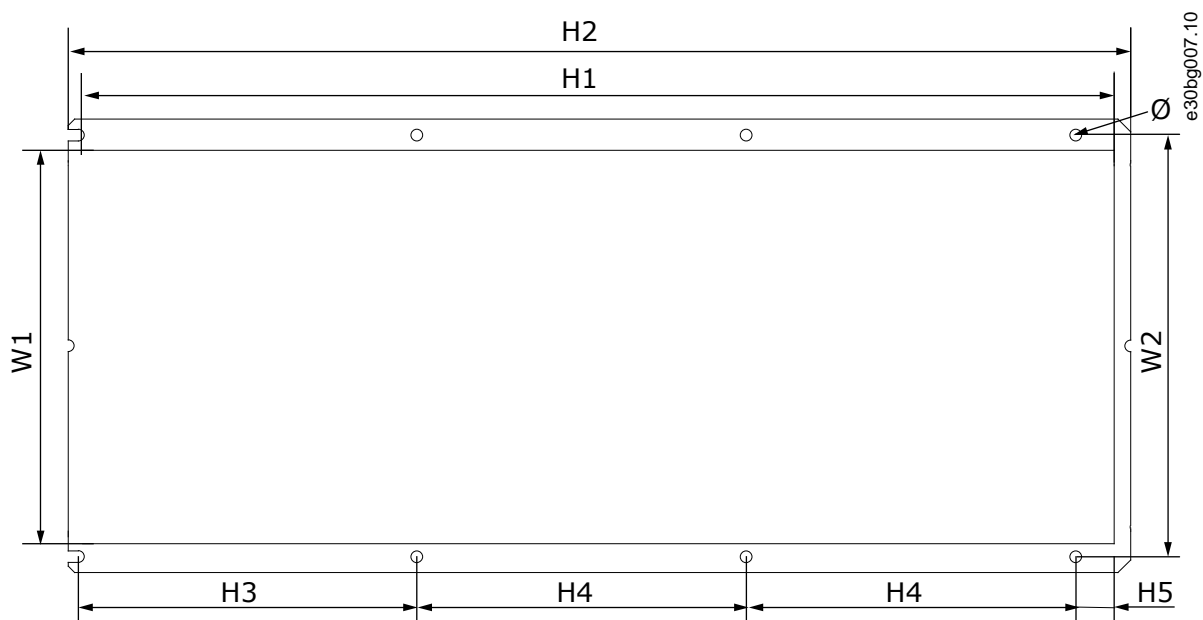

Illustration 43: Dimensions of the Opening and Drive Outline with Flange, FI8

**Table 24: Dimensions in mm (in inch) of the Opening and Drive Outline with Flange, FI8**

Drive type	W1	W2	H1	H2	H3	H4	H5	Ø
0140 5	301	330	810	832	265	258	33	9
0062 6-0100 6	(11.85)	(12.99)	(31.89)	(32.76)	(10.43)	(10.16)	(1.30)	(0.35)

## 12.3 Cable and Fuse Sizes

For cable and fuse size information, see the following topics:

- [12.3.1 Fuse Sizes for 465–800 V DC \(380–500 V AC\)](#)
- [12.3.2 Fuse Sizes for 640–1100 V DC \(525–690 V AC\)](#)
- [12.3.3 Cable Sizes for 465–800 V DC \(380–500 V AC\)](#)
- [12.3.4 Cable Sizes for 640–1100 V DC \(525–690 V AC\)](#)

### 12.3.1 Fuse Sizes for 465–800 V DC (380–500 V AC)

**Table 25: Fuse Sizes for 465–800 V DC (380–500 V AC)**

Enclosure size	Drive type	I <sup>L</sup> [A]	Bussman aR fuse type	Fuse size	Fuse U <sup>n</sup> [V]	Fuse I <sup>n</sup> [A]	No. of fuses
FI4	NXI_0004 5	4.3	170M1560	000	690	20	2
	NXI_0009 5	9	170M1562	000	690	63	2
	NXI_0012 5	12	170M1562	000	690	63	2
FI6	NXI_0016 5	16	170M1565	000	690	63	2
	NXI_0022 5	22	170M1565	000	690	63	2
	NXI_0031 5	31	170M1565	000	690	63	2
	NXI_0038 5	38	170M1567	000	690	100	2
	NXI_0045 5	45	170M1567	000	690	100	2
FI7	NXI_0061 5	61	170M1568	000	690	125	2
	NXI_0072 5	72	170M1570	000	690	200	2
	NXI_0087 5	87	170M1570	000	690	200	2
	NXI_0105 5	105	170M1571	000	690	250	2
FI8	NXI_0140	140	170M3819	1	690	400	2

### 12.3.2 Fuse Sizes for 640–1100 V DC (525–690 V AC)

**Table 26: Fuse Sizes for 640–1100 V DC (525–690 V AC)**

Enclosure size	Type	$I_L$ [A]	Bussman aR fuse type	Fuse size	Fuse $U^n$ [V]	Fuse $I^n$ [A]	No. of fuses
FI6	NXI_0004 6	4.3	170M2673	00	1000	20	2
	NXI_0005 6	5.5	170M2673	00	1000	20	2
	NXI_0007 6	7.5	170M2673	00	1000	20	2
	NXI_0010 6	10	170M2673	00	1000	20	2
	NXI_0013 6	13.5	170M2679	00	1000	63	2
	NXI_0018 6	18	170M2679	00	1000	63	2
	NXI_0022 6	22	170M2679	00	1000	63	2
	NXI_0027 6	27	170M2679	00	1000	63	2
	NXI_0034 6	34	170M2680	00	1000	160	2
	FI7	NXI_0041 6	41	170M2683	00	1000	160
NXI_0052 6		52	170M2683	00	1000	160	2
FI8	NXI_0062 6	62	170M4199	1SHT	1250	400	2
	NXI_0080 6	80	170M4199	1SHT	1250	400	2
	NXI_0100 6	100	170M4199	1SHT	1250	400	2

### 12.3.3 Cable Sizes for 465–800 V DC (380–500 V AC)

**Table 27: Cable Sizes for 465–800 V DC (380–500 V AC)**

Enclosure size	Drive type	$I_L$ [A]	Supply cable Cu [mm <sup>2</sup> ]	Motor cable Cu [mm <sup>2</sup> ]	Main terminal cable [mm <sup>2</sup> ]	Earth terminal cable [mm <sup>2</sup> ]
FI4	NXI_0004 5–0009 5	3–9	2*1.5	3*1.5+1.5	1–4	1–2.5
	NXI_0012 5	12	2*2.5	3*2.5+2.5	1–4	1–2.5
FI6	NXI_0016 5–0045 5	16–45	2*10	3*10+10	2.5–50 Cu	2.5–35
					6–50 Al	
FI7	NXI_0061 5	61	2*16	3*16+16	2.5–50 Cu	2.5–35
					6–50 Al	
	NXI_0072 5	72	2*25	3*25+16	2.5–50 Cu	6–70
					6–50 Al	
NXI_0087 5	87	2*35	3*35+16	2.5–50 Cu	6–70	
				6–50 Al		
NXI_0105 5	105	2*50	3*50+25	2.5–50 Cu	6–70	
				6–50 Al		
FI8	NXI_0140 5	140	2*70	3*70+35	25–95 Cu/Al	25–95

### 12.3.4 Cable Sizes for 640–1100 V DC (525–690 V AC)

**Table 28: Cable Sizes for 640–1100 V DC (525–690 V AC)**

Enclosure size	Drive type	$I_L$ [A]	Supply cable Cu [mm <sup>2</sup> ]	Motor cable Cu [mm <sup>2</sup> ]	Main terminal cable [mm <sup>2</sup> ]	Earth terminal cable [mm <sup>2</sup> ]
FI6	NXI_0004 6–0007 6	3–7	2*2.5	3*2.5+2.5	2.5–50 Cu	2.5–35
					6–50 Al	
	NXI_0010 6–0013 6	10–13	2*2.5	3*2.5+2.5	2.5–50 Cu	2.5–35
					6–50 Al	
	NXI_0018 6	18	2*4	3*4+4	2.5–50 Cu	2.5–35
					6–50 Al	
	NXI_0022 6	22	2*6	3*6+6	2.5–50 Cu	2.5–35
					6–50 Al	
	NXI_0027 6–0034 6	27–34	2*10	3*10+10	2.5–50 Cu	2.5–35
					6–50 Al	
FI7	NXI_0041 6	41	2*100	3*10+10	2.5–50 Cu	6–50
					6–50 Al	
	NXI_0052 6	52	2*16	3*16+16	2.5–50 Cu	6–50
					6–50 Al	
FI8	NXI_0062–0080 6	62–80	2*25	3*25+16	25–95 Cu/Al	25–95
					NXI_0100 6	

### 12.4 Cable Stripping Lengths

See [illustration 44](#) for parts of cables to be stripped and check the corresponding stripping length in the table.



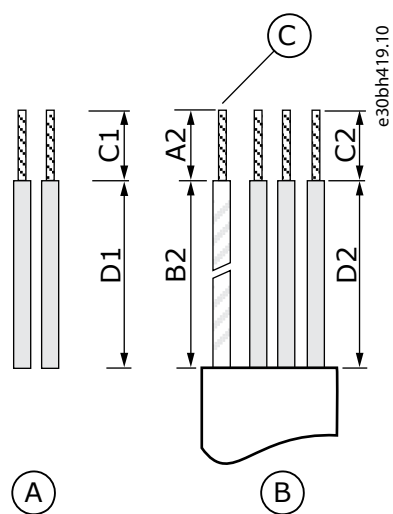

A DC supply	B Motor
C Earth conductor	

Illustration 44: Cable Stripping for DC Supply and Motor Cables

Table 29: Cable Stripping Lengths [mm]

Enclosure size	C1	D1	A2	B2	C2	D2
FI4	10	20/70	7	50	7	35
FI6	15	60/80	20	90	15	60
FI7	25	120/140	25	120	25	120
FI8	30	150	23	240	23	240
0140			28			

Table 30: Cable Stripping Lengths [in]

Enclosure size	C1	D1	A2	B2	C2	D2
FI4	0.39	0.79/2.76	0.28	1.97	0.28	1.38
FI6	0.59	2.36/3.15	0.79	3.54	0.59	2.36
FI7	0.98	4.72/5.51	0.98	4.72	0.98	4.72
FI8	1.18	5.91	0.91	9.45	0.91	9.45
0140						

## 12.5 Tightening Torques for Cover Screws

Enclosure size and class	Cable cover screws (Nm)	Screws on the cover of the AC drive (Nm)
FR4/FI4 IP54	2.2	0.7
FR5 IP21/ IP54	2.2	0.7
FR6/FI6 IP21/ IP54	2.2	0.7
FR7/FI7 IP21/ IP54	2.4	0.8
FR8/FI8 IP54	0.8 Nm <sup>(1)</sup>	0.8
FR9	0.8	0.8

<sup>1</sup> The cover of the power unit.

## 12.6 Tightening Torques of the Terminals

Table 31: Tightening Torques of the Terminals

Enclosure size	Drive type	Tightening torque (Nm)	Tightening torque (lb-in.)
FI4	0004 2–0012 2	0.5–0.6	4.5–5.3
	0003 5–0012 5		
FI6	0038 5–0061 5	10	88.5
	0004 6–0034 6		
FI7	0072 5–0105 5	10	88.5
	0041 6–0080 6		
FI8	0140 5	20 <sup>(1)</sup>	354
	0062 6–0100 6		

<sup>1</sup> Tightening torque of terminal connection to the insulative base is 9 Nm

## 12.7 Power Ratings

### 12.7.1 Overload Capability

The **low overload** means that if 110% of the continuous current ( $I_L$ ) is required for 1 minute every 10 minutes, the remaining 9 minutes must be approximately 98% of  $I_L$  or less. This is to make sure that the output current is not more than  $I_L$  during the duty cycle.

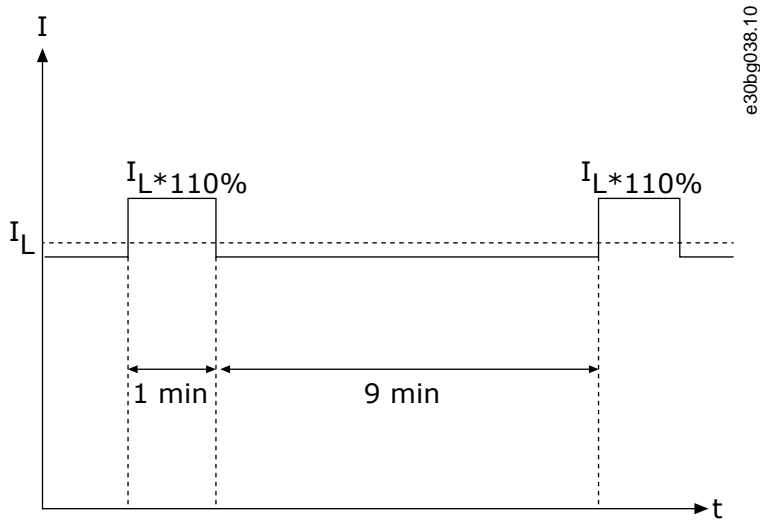

Illustration 45: Low Overload

The **high overload** means that if 150% of the continuous current ( $I_H$ ) is required for 1 minute every 10 minutes, the remaining 9 minutes must be approximately 92% of  $I_H$  or less. This is to make sure that the output current is not more than  $I_H$  during the duty cycle.

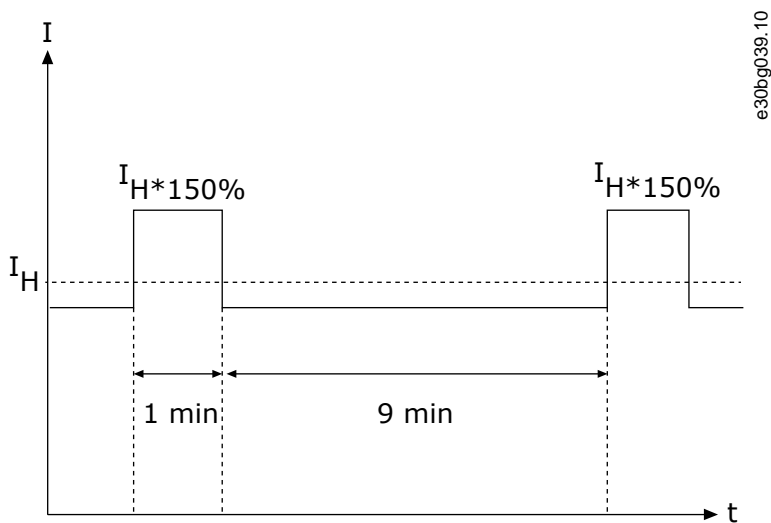

Illustration 46: High Overload

For more information, refer to the standard IEC61800-2.

### 12.7.2 Power Ratings for 465–800 V DC (380–500 V AC)

**Table 32: Power Ratings in 465–800 V DC (380–500 V AC)**

Inverter type	Enclosure size	Low loadability <sup>(1)</sup> : I <sup>L</sup> [A] <sup>(2)</sup>	Low loadability <sup>(1)</sup> : 10% overload current I [A]	High loadability <sup>(1)</sup> : I <sup>H</sup> [A]	High loadability <sup>(1)</sup> : 50% overload current I [A]	Loadability <sup>(1)</sup> : Max current I <sup>S</sup>	Motor shaft power <sup>(3)</sup> : 10% overload 40 °C [kW]	Motor shaft power <sup>(3)</sup> : 50% overload 50 °C [kW]	Motor shaft power <sup>(4)</sup> : 10% overload 40 °C [kW]	Motor shaft power <sup>(4)</sup> : 50% overload 50 °C [kW]
NXI_0004 5	FI4	4.3	4.7	3.3	5	6.2	1.5	1.1	2.2	1.5
NXI_0009 5	FI4	9	9.9	7.6	11.4	14	4	3	5.5	4
NXI_0012 5	FI4	12	13.2	9	13.5	18	5.5	4	7.5	5.5
NXI_0016 5	FI6	16	17.6	12	18	24	7.5	5.5	11	7.5
NXI_0022 5	FI6	23	25.3	16	24	32	11	7.5	15	11
NXI_0031 5	FI6	31	34	23	35	46	15	11	18.5	15
NXI_0038 5	FI6	38	42	31	47	62	18.5	15	22	18.5
NXI_0045 5	FI6	46	51	38	57	76	22	18.5	30	22
NXI_0061 5	FI7	61	67	46	69	92	30	22	37	30
NXI_0072 5	FI7	72	79	61	92	122	37	30	45	37
NXI_0087 5	FI7	87	96	72	108	144	45	37	55	45
NXI_0105 5	FI7	105	116	87	131	174	55	45	75	55
NXI_0140 5	FI8	140	154	105	158	210	75	55	90	75

<sup>1</sup> At 40 °C ambient temperature

<sup>2</sup> The rated currents in given ambient temperatures are achieved only when the switching frequency is the same or smaller than the factory default.

<sup>3</sup> 513 VDC supply

<sup>4</sup> 675 VDC supply

### 12.7.3 Power Ratings for 640–1100 V DC (525–690 V AC)

**Table 33: Power Ratings in 640–1100 V DC (525–690 V AC)**

Inverter type	Enclosure size	Low loadability <sup>(1)</sup> : I <sup>L</sup> [A]	Low loadability <sup>(1)</sup> : 10% overload current I [A]	High loadability <sup>(1)</sup> : I <sup>H</sup> [A]	High loadability <sup>(1)</sup> : 50% overload current I [A]	Loadability <sup>(1)</sup> : Max current I <sub>S</sub>	Motor shaft power <sup>(2)</sup> : 10% overload 40 °C [kW]	Motor shaft power <sup>(2)</sup> : 50% overload 50 °C [kW]
NXI_0004 6	FI6	4.5	5	3.2	5	6.7	3	2.2
NXI_0005 6	FI6	5.5	6.1	4.5	6.8	9	4	3
NXI_0007 6	FI6	7.5	8.3	5.5	8.3	11	5.5	4
NXI_0010 6	FI6	10	11	7.5	11.3	15	7.5	5.5
NXI_0013 6	FI6	13.5	14.9	10	15	20	11	7.5

Inverter type	Enclosure size	Low loadability <sup>(1)</sup> : I <sup>L</sup> [A]	Low loadability <sup>(1)</sup> : 10% overload current I [A]	High loadability <sup>(1)</sup> : I <sup>H</sup> [A]	High loadability <sup>(1)</sup> : 50% overload current I [A]	Loadability <sup>(1)</sup> : Max current I <sub>S</sub>	Motor shaft power <sup>(2)</sup> : 10% overload 40 °C [kW]	Motor shaft power <sup>(2)</sup> : 50% overload 50 °C [kW]
NXI_0018 6	FI6	18	19.8	13.5	20.3	27	15	11
NXI_0022 6	FI6	22	24.2	18	27	36	18.5	15
NXI_0027 6	FI6	27	29.7	22	33	44	22	18.5
NXI_0034 6	FI6	34	37	27	41	54	30	22
NXI_0041 6	FI7	41	45	34	51	68	37.5	30
NXI_0052 6	FI7	52	57	41	62	82	45	37.5
NXI_0062 6	FI8	62	68	52	78	104	55	45
NXI_0080 6	FI8	80	88	62	93	124	75	55
NXI_0100 6	FI8	100	110	80	120	160	90	75

<sup>1</sup> At 40 °C ambient temperature

<sup>2</sup> 930 V DC supply

## 12.8 Technical Data

**Table 34: Technical Data**

Technical item or function		Technical data
DC connection	Input voltage U <sub>in</sub>	465...800 V DC; 640...1100 V DC; -0%...+0%, the ripple voltage of the inverter supply voltage generated during the rectification of the fundamental frequency AC voltage must be less than 50 Vp-p.
	Connection to DC supply	Once per minute or less (normal)
	Starting delay	FI4–FI8: 2 s
Motor connection	Output voltage	3 ~ 0 - U <sub>in</sub> /1.4
	Continuous output current	I <sub>H</sub> : Ambient temperature maximum +50 °C (+122 °F), overload 1.5 x I <sub>H</sub> (1 min/10 min)  I <sub>L</sub> : Ambient temperature maximum +40 °C (+104 °F), overload 1.1 x I <sub>L</sub> (1 min/10 min)
	Starting torque	I <sub>S</sub> for 2 s, depends on the motor
	Starting current	I <sub>S</sub> for 2 s every 20 s
	Output frequency	0...320 Hz; 7200 Hz (special use)
	Frequency resolution	Depends on application

Technical item or function		Technical data
Control characteristics	Control method	Frequency control U/f  Open Loop Sensorless Vector Control  Closed Loop Frequency Control  Closed Loop Vector Control
	Switching frequency (see parameter 2.6.9)	NXI_XXXX 5: 1...16 kHz; Factory default 10 kHz  NXI_0072 and greater: 1...10 kHz; Factory default 3.6 kHz  NXI_XXXX 6: 1...6 kHz; Factory default 1.5 kHz
	Analog input	Resolution 0.1% (10-bit), accuracy ±1%
	Panel reference	Resolution 0.01 Hz
	Field weakening point	30...320 Hz
	Acceleration time	0...3000 s
	Deceleration time	0...3000 s

Technical item or function		Technical data
Ambient conditions	Ambient operating temperature	-10 °C (no frost) (+14 °F)...+50 °C (+122 °F): I <sub>H</sub>  -10 °C (no frost) (+14 °F)...+40 °C (+104 °F): I <sub>L</sub>
	Storage temperature	-40 °C (-40 °F)...+70 °C (158 °F)
	Relative humidity	0–95% RH, non-condensing, non-corrosive, no dripping water
	<b>Air quality:</b> <ul style="list-style-type: none"> <li>chemical vapors</li> <li>mechanical particles</li> </ul>	Designed according to:  IEC 60721-3-3, unit in operation, class 3C2  IEC 60721-3-3, unit in operation, class 3S2
	Altitude	100% load capacity (no derating) up to 1000 m  1-% derating for each 100 m above 1000 m; maximum 500 V units: 3000 m, 690V units: 2000 m
	<b>Vibration</b>	5–150 Hz
	IEC/EN 60068-2-6	Displacement amplitude 1 mm (peak) at 5–15.8 Hz
	IEC/EN 61800-5-1	Maximum acceleration amplitude 1 G at 15.8–150 Hz
	<b>Shock</b>	UPS Drop Test (for applicable UPS weights)
	EN50178, EN60068-2-27	Storage and shipping: Maximum 15 G, 11 ms (in package)
	Enclosure class	FI4...FI7 IP21/NEMA1 standard  FI8 IP00 standard/Open type standard size in the kW/HP range
	Derating	The output power must be derated in following cases: <ul style="list-style-type: none"> <li>Ambient temperature is more than 40 °C (104 °F), see <a href="#">5.1.2 Ambient Temperature and Derating</a>.</li> <li>Installation altitude is more than 1000 m, see <a href="#">5.1.3 High Altitude Installation</a>.</li> </ul>
EMC (at default settings)	Immunity	IEC/EN 61800-3
Safety standards		IEC/EN 61800-5-1, UL 508C, CSA C22.2 No.274
Approvals		CE, cULus, RCM, KC, EAC, UA (see nameplate of the drive for more approvals.) Marine approvals: LR, BV, DNV, GL, ABS, RMRS, CCS, KR
Efficiency		See <a href="https://www.danfoss.com/en/about-danfoss/our-businesses/drives/knowledge-center/energy-efficiency-directive/">https://www.danfoss.com/en/about-danfoss/our-businesses/drives/knowledge-center/energy-efficiency-directive/</a>

Technical item or function		Technical data
Control connections	Analog input voltage	0...+10 V, Ri = 200 kW, (-10 V...+10 V joystick control)  Resolution 0.1%, accuracy ±1%
	Analog input current	0(4)...20 mA, Ri = 250 W differential
	Digital inputs (6)	Positive or negative logic; 18...30 V DC
	Auxiliary voltage	+24 V, ±15%, maximum 250 mA
	Output reference voltage	+10 V, +3%, maximum load 10 mA
	Analog output	0(4)...20 mA; RL maximum 500 W; Resolution 10 bit; Accuracy ±2%
	Digital outputs	Open collector output, 50 mA/48 V
	Relay outputs	2 programmable change-over relay outputs  Switching capacity 24 V DC/8 A, 250 V AC/8 A, 125 V DC/0.4 A  Minimum switching load: 5 V/10m A
Protections	Overvoltage trip limit	NXI_5: 911 V DC  NXI_6: 1200 V DC
	Undervoltage trip limit	NXI_5: 333 V DC  NXI_6: 460 V DC
	Earth fault protection	If there is ground fault in motor or motor cable, only the inverter is protected
	Output phase supervision	Trips if any of the output phases is missing
	Overcurrent protection	Yes. <sup>(1)</sup> The motor overload protection activates at 110% of the full load current.
	Unit overtemperature protection	Yes
	Motor overload protection	Yes
	Motor stall protection	Yes
	Motor underload protection	Yes
	Short-circuit protection of +24 V and +10 V reference voltages	Yes

<sup>1</sup> For the motor thermal memory and the memory retention function to comply with the UL 508C requirements, use the system software version NXS00001V175, NXS00002V177, or NXP00002V186 or a newer version. With an older system software version, install a motor overtemperature protection to comply with the UL regulations.

## 12.9 DC Currents and DC Link Capacitance

For DC currents, see:

- [12.9.1 DC Currents, Supply Voltage 465–800 V DC](#)
- [12.9.2 DC Currents, Supply Voltage 640–1100 V DC](#)

For DC link capacitance, see [12.9.3 DC Link Capacitance](#).



### 12.9.1 DC Currents, Supply Voltage 465–800 V DC

**Table 35: DC Currents of VACON® NX, Supply Voltage 465–800 V DC**

Structure	I <sub>N</sub> (output)	Motor cos	I <sub>DC</sub> (input)
FI4	4.3	0.79	4.4
	9	0.82	9.6
	12	0.83	1.0
FI6	16	0.84	17.5
	22	0.85	24.4
	31	0.85	34.3
	38	0.86	43
	45	0.86	50
FI7	61	0.86	68
	72	0.87	82
	87	0.87	99
	105	0.87	119
FI8	140	0.88	160

### 12.9.2 DC Currents, Supply Voltage 640–1100 V DC

**Table 36: DC Currents of VACON® NX, Supply Voltage 640–1100 V DC**

Structure	I <sub>N</sub> (output)	Motor cos	I <sub>DC</sub> (input)
FI6	4.5	0.81	4.7
	5.5	0.82	5.9
	7.5	0.83	8.1
	10.0	0.84	10.9
	13.5	0.85	14.9
	18.0	0.85	19.9
	22.0	0.86	24.6
	27.0	0.86	30.2
	34.0	0.86	38.1
FI7	41.0	0.87	46
	52.0	0.87	59
FI8	62.0	0.87	70
	80.0	0.88	92
	100.0	0.88	115

### 12.9.3 DC Link Capacitance

Table 37: DC Link Capacitance

Structure	NXI_5 / mF	NXI_6 / mF
FI4 0003–0007	165	–
FI4 0009–0012	235	
FI6	1000	500
FI7	1650	900
FI8	3300	1800

### 12.10 Faults and Alarms

#### 12.10.1 Fault 1 - Overcurrent, Subcode S1- Hardware trip

##### Cause

There is too high a current ( $>4 \cdot I_H$ ) in the motor cable. Its cause can be 1 of the following:

- a sudden heavy load increase
- a short circuit in the motor cables
- the motor is not the correct type

##### Troubleshooting

- Do a check of the loading.
- Do a check of the motor.
- Do a check of the cables and connections.
- Make an identification run.

#### 12.10.2 Fault 1 - Overcurrent, Subcode S3 - Current limit controller supervision

##### Cause

There is too high a current ( $>4 \cdot I_H$ ) in the motor cable. Its cause can be 1 of the following:

- a sudden heavy load increase
- a short circuit in the motor cables
- the motor is not the correct type

##### Troubleshooting

- Do a check of the loading.
- Do a check of the motor.
- Do a check of the cables and connections.
- Make an identification run.

### 12.10.3 Fault 1 - Overcurrent, Subcode S4 - Software-based overcurrent fault

#### Cause

There is too high a current in the motor cable. Its cause can be 1 of the following:

- a sudden heavy load increase
- a short circuit in the motor cables
- the motor is not the correct type

#### Troubleshooting

- Do a check of the loading.
- Do a check of the motor.
- Do a check of the cables and connections.
- Make an identification run.

### 12.10.4 Fault 2 - Overvoltage, Subcode S1 - Hardware trip

#### Cause

The DC-link voltage is higher than the limits.

- Too short a deceleration time
- High overvoltage spikes in the supply
- Start/Stop sequence too fast

#### Troubleshooting

- Set the deceleration time longer.
- Use the brake chopper or the brake resistor. They are available as options.
- Activate the overvoltage controller.
- Do a check of the input voltage.

### 12.10.5 Fault 2 - Overvoltage, Subcode S2 - Overvoltage control supervision

#### Cause

The DC-link voltage is higher than the limits.

- Too short a deceleration time
- High overvoltage spikes in the supply
- Motor load is generative
- Start/Stop sequence too fast

#### Troubleshooting

- Set the deceleration time longer.
- Use the brake chopper or the brake resistor. They are available as options.
- Activate the overvoltage controller.
- Do a check of the input voltage.

### 12.10.6 Fault 3 - Earth fault

#### Cause

The measurement of current tells that the sum of the motor phase current is not zero.

- Insulation malfunction in the cables or in the motor.

It is possible to set different responses in the application for this fault. See parameter group Protections.

#### Troubleshooting

Do a check of the motor cables and the motor.

### 12.10.7 Fault 5 - Charging switch

#### Cause

The charging switch is open, when the START command is given.

- Operation malfunction
- Defective component

#### Troubleshooting

- Reset the fault and start the drive again.
- If the fault shows again, ask instructions from the local distributor.

### 12.10.8 Fault 6 - Emergency stop

#### Cause

Stop signal has been given from the option board.

#### Troubleshooting

Do a check of the emergency stop circuit.

### 12.10.9 Fault 7 - Saturation trip

#### Cause

- defective component
- brake resistor short circuit or overload

#### Troubleshooting

This fault cannot be reset from the control panel.

- Switch off the power.
- DO NOT RESTART THE DRIVE or CONNECT THE POWER!
- Ask instructions from the factory. If this fault shows at the same time with Fault 1, do a check of the motor cable and the motor.

### 12.10.10 Fault 8 - System fault, Subcode S1 - ASIC phase feedback

#### Cause

- operation malfunction
- defective component

#### Troubleshooting

- Reset the fault and start the drive again.
- If the fault shows again, ask instructions from the local distributor.

### 12.10.11 Fault 8 - System fault, Subcode S4 - ASIC trip

#### Cause

- operation malfunction
- defective component

#### Troubleshooting

- Reset the fault and start the drive again.
- If the fault shows again, ask instructions from the local distributor.

### 12.10.12 Fault 8 - System fault, Subcode S5 - Disturbance in VaconBus

#### Cause

- operation malfunction
- defective component

#### Troubleshooting

- Reset the fault and start the drive again.
- If the fault shows again, ask instructions from the local distributor.

### 12.10.13 Fault 8 - System fault, Subcode S6 - Feedback of charging switch

#### Cause

- operation malfunction
- defective component

#### Troubleshooting

- Reset the fault and start the drive again.
- If the fault shows again, ask instructions from the local distributor.

### 12.10.14 Fault 8 - System fault, Subcode S7 - Charging switch

#### Cause

- operation malfunction
- defective component

**Troubleshooting**

- Reset the fault and start the drive again.
- If the fault shows again, ask instructions from the local distributor.

**12.10.15 Fault 8 - System fault, Subcode S8 - No power to driver card****Cause**

- operation malfunction
- defective component

**Troubleshooting**

- Reset the fault and start the drive again.
- If the fault shows again, ask instructions from the local distributor.

**12.10.16 Fault 8 - System fault, Subcode S9 - Power unit communication (TX)****Cause**

- operation malfunction
- defective component

**Troubleshooting**

- Reset the fault and start the drive again.
- If the fault shows again, ask instructions from the local distributor.

**12.10.17 Fault 8 - System fault, Subcode S10 - Power unit communication (Trip)****Cause**

- operation malfunction
- defective component

**Troubleshooting**

- Reset the fault and start the drive again.
- If the fault shows again, ask instructions from the local distributor.

**12.10.18 Fault 8 - System fault, Subcode S11 - Power unit comm. (Measurement)****Cause**

- operation malfunction
- defective component

**Troubleshooting**

- Reset the fault and start the drive again.
- If the fault shows again, ask instructions from the local distributor.

### 12.10.19 Fault 8 - System fault, Subcode S12 - System bus fault (slot D or E)

#### Cause

Error in system bus option board (OPTD1 or OPTD2) in slot D or E.

- operation malfunction
- defective component

#### Troubleshooting

- Reset the fault and start the drive again.
- If the fault shows again, ask instructions from the local distributor.
- Check the cables and connections.

### 12.10.20 Fault 8 - System fault, Subcode S30 - OPTAF: STO channels are different from each other

#### Cause

The Safe Disable inputs are in different states. It is not allowed according to EN954-1, category 3. This fault occurs when the Safe Disable inputs are in different states for more than 5 s.

#### Troubleshooting

- Check the S1 switch.
- Check the cabling to the OPTAF board.
- If the fault shows again, ask instructions from the local distributor.

### 12.10.21 Fault 8 - System fault, Subcode S31 - OPTAF: Thermistor short circuit detected

#### Cause

Thermistor short circuit detected.

#### Troubleshooting

- Correct the cable connections.
- Check the jumper for the thermistor short circuit supervision, if the thermistor function is not used and the thermistor input is short-circuited.

### 12.10.22 Fault 8 - System fault, Subcode S32 - OPTAF board has been removed

#### Cause

OPTAF board has been removed. It is not allowed to remove the OPTAF board once the software has recognized it.

#### Troubleshooting

The system requires a manual acknowledgement using *System* menu parameter 6.5.5 OPTAF Remove. Ask help from the local distributor.

### 12.10.23 Fault 8 - System fault, Subcode S33 - OPTAF: EEPROM error

#### Cause

OPTAF board EEPROM error (checksum, not answering and so on).

#### Troubleshooting

Change the OPTAF board.

### 12.10.24 Fault 8 - System fault, Subcode S34 - OPTAF: Voltage problem

#### Cause

OPTAF supply voltage hardware problem detected.

#### Troubleshooting

Change the OPTAF board.

### 12.10.25 Fault 8 - System fault, Subcode S35 - OPTAF: Overvoltage

#### Cause

OPTAF supply voltage hardware problem detected.

#### Troubleshooting

Change the OPTAF board.

### 12.10.26 Fault 8 - System fault, Subcode S36 - OPTAF: Undervoltage

#### Cause

OPTAF supply voltage hardware problem detected.

#### Troubleshooting

Change the OPTAF board.

### 12.10.27 Fault 8 - System fault, Subcode S37 - OPTAF: Test pulse is not detected in both STO channels

#### Cause

Single hardware problem detected in Safe Disable inputs.

#### Troubleshooting

- Change the OPTAF board.
- Change the control board.



### 12.10.28 Fault 8 - System fault, Subcode S38 - OPTAF: Test pulse is not detected in STO channel 1

#### Cause

Single hardware problem detected in Safe Disable inputs.

#### Troubleshooting

- Change the OPTAF board.
- Change the control board.

### 12.10.29 Fault 8 - System fault, Subcode S39 - OPTAF: Test pulse is not detected in STO channel 2

#### Cause

Single hardware problem detected in Safe Disable inputs.

#### Troubleshooting

- Change the OPTAF board.
- Change the control board.

### 12.10.30 Fault 8 - System fault, Subcode S40 - OPTAF: ASIC trip ETR is not set, even if STO channel 1 is active

#### Cause

Single hardware problem detected in Safe Disable inputs.

#### Troubleshooting

- Change the OPTAF board.
- Change the control board.

### 12.10.31 Fault 8 - System fault, Subcode S41 - OPTAF: STO channels are not active when the thermistor trip is active

#### Cause

Single hardware problem detected in the thermistor input.

#### Troubleshooting

Change the OPTAF board.

### 12.10.32 Fault 8 - System fault, Subcode S42 - OPTAF: Test pulse low is not detected on thermistor

#### Cause

Single hardware problem detected in the thermistor input.

#### Troubleshooting

Change the OPTAF board.

### 12.10.33 Fault 8 - System fault, Subcode S43 - OPTAF: Test pulse high is not detected on thermistor

#### Cause

Single hardware problem detected in the thermistor input.

#### Troubleshooting

Change the OPTAF board.

### 12.10.34 Fault 8 - System fault, Subcode S44 - OPTAF: STO channel 1 is not active, even if the analog input supervision indicates

#### Cause

Single hardware problem detected in Safe Disable inputs or in the thermistor input.

#### Troubleshooting

- Change the OPTAF board.
- Change the control board.

### 12.10.35 Fault 8 - System fault, Subcode S45 - OPTAF: STO channel 2 is not active, even if the analog input supervision indicates

#### Cause

Single hardware problem detected in Safe Disable inputs or in the thermistor input.

#### Troubleshooting

- Change the OPTAF board.
- Change the control board.

### 12.10.36 Fault 8 - System fault, Subcode S46 - OPTAF: Thermistor or analog input is not set, even if STO is active

#### Cause

Single hardware problem detected in Safe Disable inputs or in the thermistor input.

#### Troubleshooting

- Change the OPTAF board.
- Change the control board.

### 12.10.37 Fault 8 - System fault, Subcode S47 - OPTAF: Board mounted in old NXP control board with no safety hardware

#### Cause

OPTAF board mounted in old VACON® NXP control board, which is not equipped with the Safe Disable function.

#### Troubleshooting

Change the control board to VB00561 revision H or newer.

### 12.10.38 Fault 8 - System fault, Subcode S48 - OPTAF: Mismatch between Therm Trip (HW) parameter and jumper setting

#### Cause

The parameter Expander boards/ SlotB/ Therm Trip(HW) is set to OFF even though the jumper X12 is not cut.

#### Troubleshooting

Correct the parameter 7.2.1.1 Therm Trip (HW) to match the X12 jumper setting.

### 12.10.39 Fault 8 - System fault, Subcode S49 - OPTAF: Board mounted in VACON NXS control board

#### Cause

OPTAF is only compatible with VACON® NXP.

#### Troubleshooting

Remove the OPTAF board.

### 12.10.40 Fault 8 - System fault, Subcode S50 - OPTAF: Filter discharge resistor fault

#### Cause

Problem with the control board.

#### Troubleshooting

Ask instructions from the local distributor.

### 12.10.41 Fault 8 - System fault, Subcode S70 - False fault activated

#### Cause

Fault in application.

### Troubleshooting

Ask instructions from the local distributor.

## 12.10.42 Fault 9 - Undervoltage, Subcode S1 - DC-link too low during run

### Cause

The DC-link voltage is lower than the limits.

- Too low a supply voltage
- AC drive internal fault
- A defective input fuse
- The external charge switch is not closed.

It is possible to set different responses in the application for this fault. See parameter group Protections.

### Troubleshooting

- If there is a temporary supply voltage break, reset the fault and start the drive again.
- Do a check of the supply voltage. If the supply voltage is sufficient, there is an internal fault.
- Ask instructions from the local distributor.

## 12.10.43 Fault 9 - Undervoltage, Subcode S2 - No data from power unit

### Cause

The DC-link voltage is lower than the limits.

- Too low a supply voltage
- AC drive internal fault
- a defective input fuse
- the external charge switch is not closed.

It is possible to set different responses in the application for this fault. See parameter group Protections.

### Troubleshooting

- If there is a temporary supply voltage break, reset the fault and start the drive again.
- Do a check of the supply voltage. If the supply voltage is sufficient, there is an internal fault.
- Ask instructions from the local distributor.

## 12.10.44 Fault 9 - Undervoltage, Subcode S3 - Undervoltage control supervision

### Cause

The DC-link voltage is lower than the limits.

- Too low a supply voltage
- AC drive internal fault
- A defective input fuse
- The external charge switch is not closed.

It is possible to set different responses in the application for this fault. See parameter group Protections.

#### Troubleshooting

- If there is a temporary supply voltage break, reset the fault and start the drive again.
- Do a check of the supply voltage. If the supply voltage is sufficient, there is an internal fault.
- Ask instructions from the local distributor.

### 12.10.45 Fault 10 - Input line supervision, Subcode S1 - Phase supervision diode supply

#### Cause

The input line phase is missing.

It is possible to set different responses in the application for this fault. See parameter group Protections.

#### Troubleshooting

Do a check of the supply voltage, the fuses, and supply cable.

### 12.10.46 Fault 11 - Output phase supervision, Subcode S1 - Common output phase supervision

#### Cause

The measurement of current tells that there is no current in 1 motor phase.

It is possible to set different responses in the application for this fault. See parameter group Protections.

#### Troubleshooting

Do a check of the motor cable and the motor.

### 12.10.47 Fault 11 - Output phase supervision, Subcode S2 - Additional closed loop control output phase fault

#### Cause

The measurement of current tells that there is no current in 1 motor phase.

It is possible to set different responses in the application for this fault. See parameter group Protections.

#### Troubleshooting

Do a check of the motor cable and the motor.

### 12.10.48 Fault 11 - Output phase supervision, Subcode S3 - Additional open loop control output phase fault during start DC brake

#### Cause

The measurement of current tells that there is no current in 1 motor phase.

It is possible to set different responses in the application for this fault. See parameter group Protections.

#### Troubleshooting

Do a check of the motor cable and the motor.

### 12.10.49 Fault 11 - Output phase supervision, Subcode S4 - Additional closed loop output phase fault during PM StartAngleID run

#### Cause

The measurement of current tells that there is no current in 1 motor phase.

It is possible to set different responses in the application for this fault. See parameter group Protections.

#### Troubleshooting

Do a check of the motor cable and the motor.

### 12.10.50 Fault 12 - Brake chopper supervision

#### Cause

- There is no brake resistor.
- The brake resistor is broken.
- A defective brake chopper.

#### Troubleshooting

- Do a check of the brake resistor and the cabling.
- If they are in good condition, there is a fault in the resistor or the brake chopper. Ask instructions from the local distributor.

### 12.10.51 Fault 13 - AC drive undertemperature

#### Cause

Too low a temperature in the heat sink of the power unit or in the power board. The heat sink temperature is below -10 °C (14 °F).

#### Troubleshooting

Add an external heater near the AC drive.

### 12.10.52 Fault 14 - AC drive overtemperature, Subcode S1 - Overtemperature warning in unit, board, or phases

#### Cause

Overheating detected in AC drive.

Heat sink temperature is over 90 °C (194 °F). Overtemperature alarm is issued when the heat sink temperature goes over 85 °C (185 °F).

In 525–690 V, FR6: Heat sink temperature is over 77 °C (170.6 °F). Overtemperature alarm is issued when the heat sink temperature goes over 72 °C (161.6 °F).

#### Troubleshooting

- Do a check of the actual amount and flow of cooling air.
- Examine the heat sink for dust.
- Do a check of the ambient temperature.
- Make sure that the switching frequency is not too high in relation to the ambient temperature and the motor load.

### 12.10.53 Fault 14 - AC drive overtemperature, Subcode S2 - Overtemperature in power board

#### Cause

Overheating detected in AC drive.

Heat sink temperature is over 90 °C (194 °F). Overtemperature alarm is issued when the heat sink temperature goes over 85 °C (185 °F).

In 525–690 V, FR6: Heat sink temperature is over 77 °C (170.6 °F). Overtemperature alarm is issued when the heat sink temperature goes over 72 °C (161.6 °F).

#### Troubleshooting

- Do a check of the actual amount and flow of cooling air.
- Examine the heat sink for dust.
- Do a check of the ambient temperature.
- Make sure that the switching frequency is not too high in relation to the ambient temperature and the motor load.

### 12.10.54 Fault 14 - AC drive overtemperature, Subcode S4 - Overtemperature on ASIC board or driver boards

#### Cause

Overheating detected in AC drive.

Heat sink temperature is over 90 °C (194 °F). Overtemperature alarm is issued when the heat sink temperature goes over 85 °C (185 °F).

In 525–690 V, FR6: Heat sink temperature is over 77 °C (170.6 °F). Overtemperature alarm is issued when the heat sink temperature goes over 72 °C (161.6 °F).

#### Troubleshooting

- Do a check of the actual amount and flow of cooling air.
- Examine the heat sink for dust.
- Do a check of the ambient temperature.
- Make sure that the switching frequency is not too high in relation to the ambient temperature and the motor load.

### 12.10.55 Fault 15 - Motor stalled

#### Cause

The motor stalled.

It is possible to set different responses in the application for this fault. See parameter group Protections.

#### Troubleshooting

- Check the motor and the load.
- Insufficient motor power, check motor stall protection parameterization.

### 12.10.56 Fault 16 - Motor overtemperature

#### Cause

There is too heavy a load on the motor.

It is possible to set different responses in the application for this fault. See parameter group Protections.

#### Troubleshooting

- Decrease the motor load.
- If there is no motor overload, do a check of the temperature model parameters.

### 12.10.57 Fault 17 - Motor underload

#### Cause

Motor underload protection has tripped.

It is possible to set different responses in the application for this fault. See parameter group Protections.

#### Troubleshooting

- Check the load.
- Check underload protection parameterization.

### 12.10.58 Fault 18 - Unbalance, Subcode S1 - Current unbalance

#### Cause

Unbalance between power modules in paralleled power units.



This fault is type A fault (Alarm).

#### Troubleshooting

If the fault occurs again, ask instructions from the local distributor.

### 12.10.59 Fault 18 - Unbalance, Subcode S2 - DC voltage unbalance

#### Cause

Unbalance between power modules in paralleled power units.

This fault is type A fault (Alarm).

#### Troubleshooting

If the fault occurs again, ask instructions from the local distributor.

### 12.10.60 Fault 19 - Current overload

#### Cause

Motor current overload warning.

#### Troubleshooting

Ask instructions from the local distributor.

### 12.10.61 Fault 22 - Parameter fault, Subcode S1 - Firmware interface power down variable checksum error

#### Cause

Parameter save fault.

- Operation malfunction
- defective component

#### Troubleshooting

If the fault occurs again, ask instructions from the local distributor.

### 12.10.62 Fault 22 - Parameter fault, Subcode S2 - Firmware interface variable check sum error

#### Cause

Parameter save fault.

- Operation malfunction
- defective component

### Troubleshooting

If the fault occurs again, ask instructions from the local distributor.

## 12.10.63 Fault 22 - Parameter fault, Subcode S3 - System power down variable check sum error

### Cause

Parameter save fault.

- Operation malfunction
- defective component

### Troubleshooting

If the fault occurs again, ask instructions from the local distributor.

## 12.10.64 Fault 22 - Parameter fault, Subcode S4 - System parameter checksum error

### Cause

Parameter save fault.

- Operation malfunction
- defective component

### Troubleshooting

If the fault occurs again, ask instructions from the local distributor.

## 12.10.65 Fault 22 - Parameter fault, Subcode S5 - Application-defined power-down, variable checksum error

### Cause

Parameter save fault.

- Operation malfunction
- defective component

### Troubleshooting

If the fault occurs again, ask instructions from the local distributor.

### 12.10.66 Fault 22 - Parameter fault, Subcode S6 - Application-defined power-down, variable checksum

#### Cause

Parameter save fault.

- Operation malfunction
- defective component

#### Troubleshooting

If the fault occurs again, ask instructions from the local distributor.

### 12.10.67 Fault 22 - Parameter fault, Subcode S10 - System parameter checksum error

#### Cause

Parameter save fault.

- Operation malfunction
- defective component

#### Troubleshooting

If the fault occurs again, ask instructions from the local distributor.

### 12.10.68 Fault 22 - Parameter fault, Subcode S13 - Checksum error in application-specific parameter set

#### Cause

Parameter save fault.

#### Troubleshooting

- Recommission the application.
- Check parameters.

### 12.10.69 Fault 24 - Counter fault

#### Cause

Values that showed on the counters are incorrect.

#### Troubleshooting

Have a critical attitude towards values shown on counters.

### 12.10.70 Fault 25 - Microprocessor watchdog fault, Subcode S1 - CPU watchdog timer

#### Cause

- operation malfunction
- defective component

#### Troubleshooting

- Reset the fault and start the drive again.
- If the fault shows again, ask instructions from the local distributor.

### 12.10.71 Fault 25 - Microprocessor watchdog fault, Subcode S2 - ASIC reset

#### Cause

- operation malfunction
- defective component

#### Troubleshooting

- Reset the fault and start the drive again.
- If the fault shows again, ask instructions from the local distributor.

### 12.10.72 Fault 26 - Start-up prevented, Subcode S1 - Prevention of accidental start-up

#### Cause

Start-up of the drive has been prevented. Run request is ON when new application is downloaded to the drive.

#### Troubleshooting

- Cancel prevention of start-up if it can be done safely.
- Remove Run request.

### 12.10.73 Fault 26 - Start-up prevented, Subcode S2 - RUN request is kept active after drive returns to READY state from safe state

#### Cause

Start-up of the drive has been prevented. START command is ON when returning to READY state after Safe Disable has been active.

#### Troubleshooting

- Cancel prevention of start-up if it can be done safely.
- Remove Run request.

### 12.10.74 Fault 26 - Start-up prevented, Subcode S30 - RUN request given too quickly

#### Cause

Start-up of the drive has been prevented. START command is ON after system software or application was downloaded, or after application was changed.

#### Troubleshooting

- Cancel prevention of start-up if it can be done safely.
- Remove Run request.

### 12.10.75 Fault 29 - Thermistor fault, Subcode S1 - Thermistor input activated on OPTAF board

#### Cause

The thermistor input of option board has detected increase of the motor temperature.

It is possible to set different responses in the application for this fault. See parameter group Protections.

#### Troubleshooting

- Do a check of the motor cooling and loading.
- Do a check of the thermistor connection.
- (If thermistor input of the option board is not in use it has to be short-circuited).

### 12.10.76 Fault 29 - Thermistor fault, Subcode S2 - Special application

#### Cause

The thermistor input of option board has detected increase of the motor temperature.

It is possible to set different responses in the application for this fault. See parameter group Protections.

#### Troubleshooting

- Do a check of the motor cooling and loading.
- Do a check of the thermistor connection.
- (If thermistor input of the option board is not in use it has to be short-circuited).

### 12.10.77 Fault 30 - Safe disable

#### Cause

The input on OPTAF board has opened.

STO inputs SD1 and SD2 are activated through the OPTAF option board.

#### Troubleshooting

Cancel Safe Disable if it can be done safely.

### 12.10.78 Fault 31 - IGBT temperature (hardware)

#### Cause

IGBT Inverter Bridge overtemperature protection has detected too high a short-term overload current.

**Troubleshooting**

- Do a check of the loading.
- Do a check of the motor frame size.
- Make an identification run.

**12.10.79 Fault 32 - Fan cooling****Cause**

Cooling fan of the AC drive does not start, when ON command is given.

**Troubleshooting**

Ask instructions from the local distributor.

**12.10.80 Fault 34 - CAN bus communication****Cause**

Sent message not acknowledged.

**Troubleshooting**

Make sure that there is another device on the bus with the same configuration.

**12.10.81 Fault 35 - Application****Cause**

Problem in application software.

**Troubleshooting**

- Ask instructions from the local distributor.
- For an application programmer: do a check of the application program.

**12.10.82 Fault 36 - Control unit****Cause**

- The software needs newer version of the control unit.

**Troubleshooting**

- Change the control unit.

### 12.10.83 Fault 37 - Device changed (same type), Subcode S1 - Control board

#### Cause

A new option board has replaced the old one in the same slot. The parameters are available in the drive.

#### Troubleshooting

Reset the fault. The device is ready for use. The drive starts to use the old parameter settings.

### 12.10.84 Fault 38 - Device added (same type), Subcode S1 - Control board

#### Cause

The option board was added. The same option board has been used in the same slot before. The parameters are available in the drive.

#### Troubleshooting

Reset the fault. The device is ready for use. The drive starts to use the old parameter settings.

### 12.10.85 Fault 39 - Device removed

#### Cause

An option board was removed from the slot.

#### Troubleshooting

The device is not available. Reset the fault.

### 12.10.86 Fault 40 - Device unknown, Subcode S1 - Unknown device

#### Cause

An unknown or mismatching device was connected (the power unit or option board).

#### Troubleshooting

Ask instructions from the local distributor.

### 12.10.87 Fault 40 - Device unknown, Subcode S2 - StarCoupler: power sub units are not identical

#### Cause

An unknown or mismatching device was connected (the power unit or option board).

#### Troubleshooting

Ask instructions from the local distributor.

### 12.10.88 Fault 40 - Device unknown, Subcode S3 - StarCoupler is not compatible with the control board

#### Cause

An unknown or mismatching device was connected (the power unit or option board).

#### Troubleshooting

Ask instructions from the local distributor.

### 12.10.89 Fault 40 - Device unknown, Subcode S4 - Wrong PropertiesType in control board EEPROM

#### Cause

An unknown or mismatching device was connected (the power unit or option board).

#### Troubleshooting

Ask instructions from the local distributor.

### 12.10.90 Fault 40 - Device unknown, Subcode S5 - Wrong VACON® NXP control board EEPROM size detected

#### Cause

An unknown or mismatching device was connected (the power unit or option board).

#### Troubleshooting

Ask instructions from the local distributor.

### 12.10.91 Fault 40 - Device unknown, Subcode S6 - Old power unit (Asic) and new software mismatch

#### Cause

An unknown or mismatching device was connected (the power unit or option board).

#### Troubleshooting

Ask instructions from the local distributor.

### 12.10.92 Fault 40 - Device unknown, Subcode S7 - Old ASIC detected

#### Cause

An unknown or mismatching device was connected (the power unit or option board).



### Troubleshooting

Ask instructions from the local distributor.

#### 12.10.93 Fault 41 - IGBT temperature, Subcode S1 - Calculated IGBT temperature too high

##### Cause

IGBT Inverter Bridge overtemperature protection has detected too high a short-term overload current.

##### Troubleshooting

- Do a check of the loading.
- Do a check of the motor frame size.
- Make an identification run.

#### 12.10.94 Fault 41 - IGBT temperature, Subcode S3 - Calculated IGBT temperature too high (long-term protection)

##### Cause

IGBT Inverter Bridge overtemperature protection has detected too high a short-term overload current.

##### Troubleshooting

- Do a check of the loading.
- Do a check of the motor frame size.
- Make an identification run.

#### 12.10.95 Fault 41 - IGBT temperature, Subcode S4 - Peak current too high

##### Cause

IGBT Inverter Bridge overtemperature protection has detected too high a short-term overload current.

##### Troubleshooting

- Do a check of the loading.
- Do a check of the motor frame size.
- Make an identification run.

#### 12.10.96 Fault 41 - IGBT temperature, Subcode S5 - BCU: Filtered current too high for some time

##### Cause

IGBT Inverter Bridge overtemperature protection has detected too high a short-term overload current.

#### Troubleshooting

- Do a check of the loading.
- Do a check of the motor frame size.
- Make an identification run.

### 12.10.97 Fault 41 - IGBT temperature, Subcode S6 - BCU: Current momentarily too high

#### Cause

IGBT Inverter Bridge overtemperature protection has detected too high a short-term overload current.

#### Troubleshooting

- Do a check of the loading.
- Do a check of the motor frame size.
- Make an identification run.
- Do a check brake resistor resistance.

### 12.10.98 Fault 42 - Brake resistor overtemperature, Subcode S1 - Internal brake chopper overtemperature

#### Cause

Brake resistor overtemperature protection has detected too heavy braking.

#### Troubleshooting

- Reset unit.
- Set the deceleration time longer.
- Dimensioning of the brake chopper is not correct.
- Use external brake resistor.

### 12.10.99 Fault 42 - Brake resistor overtemperature, Subcode S2 - Brake resistance too high (BCU)

#### Cause

Brake resistor overtemperature protection has detected too heavy braking.

#### Troubleshooting

- Reset unit.
- Set the deceleration time longer.
- Dimensioning of the brake chopper is not correct.
- Use external brake resistor.

### 12.10.100 Fault 42 - Brake resistor overtemperature, Subcode S3 - Brake resistance too low (BCU)

#### Cause

Brake resistor overtemperature protection has detected too heavy braking.

#### Troubleshooting

- Reset unit.
- Set the deceleration time longer.
- Dimensioning of the brake chopper is not correct.
- Use external brake resistor.

### 12.10.101 Fault 42 - Brake resistor overtemperature, Subcode S4 - Brake resistance not detected (BCU)

#### Cause

Brake resistor overtemperature protection has detected too heavy braking.

#### Troubleshooting

- Reset unit.
- Set the deceleration time longer.
- Dimensioning of the brake chopper is not correct.
- Use external brake resistor.

### 12.10.102 Fault 42 - Brake resistor overtemperature, Subcode S5 - Brake resistance leakage (earth fault) (BCU)

#### Cause

Brake resistor overtemperature protection has detected too heavy braking.

#### Troubleshooting

- Reset unit.
- Set the deceleration time longer.
- Dimensioning of the brake chopper is not correct.
- Use external brake resistor.

### 12.10.103 Fault 43 - Encoder fault, Subcode S1 - Encoder 1 channel A is missing

#### Cause

Problem detected in encoder signals.

Encoder channel A is missing.

### Troubleshooting

- Do a check of the encoder connections.
- Do a check of the option board.
- Measure the encoder pulses.
  - If the pulses are correct, the option board is faulty.
  - If the pulses are not correct, the encoder/cabling is faulty.

#### 12.10.104 Fault 43 - Encoder fault, Subcode S2 - Encoder 1 channel B is missing

### Cause

Problem detected in encoder signals.

Encoder channel B is missing.

### Troubleshooting

- Do a check of the encoder connections.
- Do a check of the option board.
- Measure the encoder pulses.
  - If the pulses are correct, the option board is faulty.
  - If the pulses are not correct, the encoder/cabling is faulty.

#### 12.10.105 Fault 43 - Encoder fault, Subcode S3 - Both encoder 1 channels are missing

### Cause

Problem detected in encoder signals.

Encoder channels A and B are missing.

### Troubleshooting

- Do a check of the encoder connections.
- Do a check of the option board.
- Measure the encoder pulses.
  - If the pulses are correct, the option board is faulty.
  - If the pulses are not correct, the encoder/cabling is faulty.

#### 12.10.106 Fault 43 - Encoder fault, Subcode S4 - Encoder reversed

### Cause

Problem detected in encoder signals.

The encoder is reversed. The output frequency has been set to the positive value, but the encoder signal is negative.

### Troubleshooting

Change the frequency value polarity so that the encoder signal is positive. With some encoders, interchanging the encoder channels can be used to change the indicated rotation direction.

#### 12.10.107 Fault 43 - Encoder fault, Subcode S5 - Encoder board missing

##### Cause

The encoder board is missing.

##### Troubleshooting

- Do a check of the encoder board.
- Do a check of the terminals.
- Do a check of the board connections.

#### 12.10.108 Fault 43 - Encoder fault, Subcode S6 - Serial communication fault

##### Cause

Problem detected in encoder signals.

Serial communication fault. The encoder cable is not connected or there are interferences in the cable.

##### Troubleshooting

- Check cabling between encoder and OPTBE, especially Data and Clock signals.
- Check that actual encoder type matches with OPTBE "Operating mode" parameter.

#### 12.10.109 Fault 43 - Encoder fault, Subcode S7 - Ch A / Ch B Mismatch

##### Cause

Problem detected in encoder signals.

Encoder channels A and B are mismatched.

##### Troubleshooting

Do a check of the cable connections and terminals.

#### 12.10.110 Fault 43 - Encoder fault, Subcode S8 - Resolver/Motor pole pair mismatch

##### Cause

Problem detected in parameterization of option board.

There is a mismatch of the resolver/ motor pole pair number. Resolver pole pair number (if >1) is not matching the motor pole pair number.

### Troubleshooting

Check that OPTBC parameter "Resolver Poles" and possible Gear Ratio parameters in application match motor pole count.

#### 12.10.111 Fault 43 - Encoder fault, Subcode S9 - Missed Start Angle

##### Cause

Encoder zero positioning identification run has not been made.

The encoder start angle is missing.

##### Troubleshooting

Make encoder identification run.

#### 12.10.112 Fault 43 - Encoder fault, Subcode S10 - Sin/Cos encoder feedback is missing

##### Cause

Problem detected in encoder signals.

For the closed loop control, encoder modes "EnDat only" or "SSI only" (absolute channel only) are not allowed.

##### Troubleshooting

- Do a check of the wiring, jumper settings, and encoder mode.
- Change OPTBE "Operating mode" parameter is either "EnDat+SinCos", "SSI+SinCos" or "SinCos only", or avoid using closed loop control.

#### 12.10.113 Fault 43 - Encoder fault, Subcode S11 - Encoder angle is drifting

##### Cause

Error angle between the angle read from the absolute channel and the angle calculated from the incremental channels.

##### Troubleshooting

- Check the encoder cable, cable shield, and grounding of the cable shield.
- Check the mechanical mounting of the encoder and make sure that the encoder is not slipping.
- Check the encoder parameters (for example, encoder ppr).

#### 12.10.114 Fault 43 - Encoder fault, Subcode S12 - Dual speed supervision fault

##### Cause

Encoder speed supervision. The difference between the encoder speed and estimated speed is too large. Dual speed supervision: Estimated speed and encoder speed difference is too high ( $0.05 \times f_n$  or minimum motor nominal slip frequency). See variable EstimatedShaftFrequency.

### Troubleshooting

- Check the encoder speed signal ShaftFrequency vs. EstimatedShaftFrequency.
- If the ShaftFrequency is incorrect, check the encoder, cable, and encoder parameters.
- If the EstimatedShaftFrequency is incorrect, check the motor parameters.

## 12.10.115 Fault 43 - Encoder fault, Subcode S13 - Encoder angle supervision fault

### Cause

The estimated shaft position error (estimated angle - encoder angle) is more than 90° electrical.

See variable EstimatedAngleError.

### Troubleshooting

- Repeat the encoder ID run (absolute encoders).
- Check the mechanical mounting of the encoder and make sure that the encoder is not slipping.
- Check the encoder ppr number.
- Check the encoder cable.

## 12.10.116 Fault 43 - Encoder fault, Subcode S14 - Encoder estimated missing pulse fault, switch from the CL ctrl to the OL sensorl

### Cause

Problem detected in encoder signals.

Software has detected too many missing pulses in the encoder. Closed loop control is switched to sensorless open loop control.

### Troubleshooting

- Do a check of the encoder.
- Do a check of the encoder cable, cable shield, and grounding of the cable shield.
- Do a check of the mechanical mounting of the encoder.
- Do a check of the encoder parameters.

## 12.10.117 Fault 44 - Device changed (different type), Subcode S1 - Control board

### Cause

- Option board or power unit changed.
- New device of different type or different power rating.

### Troubleshooting

- Reset.
- If option board was changed, set the option board parameters again.
- If power unit was changed, set AC drive parameters again.

### 12.10.118 Fault 45 - Device added (different type), Subcode S1 - Control board

#### Cause

Option board of different type added.

#### Troubleshooting

- Reset.
- Set the power unit parameters again.

### 12.10.119 Fault 49 - Division by zero in application

#### Cause

Division by zero has occurred in application program.

#### Troubleshooting

- If the fault shows again while the AC drive is in run state, ask instructions from the local distributor.
- For an application programmer: do a check of the application program.

### 12.10.120 Fault 50 - Analogue input $I_{in} < 4$ mA (sel. signal range 4 to 20 mA)

#### Cause

Current at the analog input is  $< 4$  mA.

- Control cable is broken or loose
- signal source has failed.

It is possible to set different responses in the application for this fault. See parameter group Protections.

#### Troubleshooting

Do a check of the current loop circuitry.

### 12.10.121 Fault 51 - External fault

#### Cause

Digital input fault.

Digital input has been programmed as external fault input and this input is active.

#### Troubleshooting

- Check the programming.
- Check the device which the error message indicates.
- Check the cabling for the respective device.



### 12.10.122 Fault 52 - Keypad communication fault

#### Cause

The connection between the control panel (or VACON® NCDrive) and the drive is defective.

#### Troubleshooting

Do a check of the control panel connection and the control panel cable.

### 12.10.123 Fault 53 - Fieldbus fault

#### Cause

The data connection between the fieldbus master and the fieldbus board is defective.

#### Troubleshooting

- Do a check of the installation and fieldbus master.
- If the installation is correct, ask instructions from the local distributor.

### 12.10.124 Fault 54 - Slot fault

#### Cause

Defective option board or slot.

#### Troubleshooting

- Do a check of the board and slot.
- Ask instructions from the local distributor.

### 12.10.125 Fault 56 - Measured Temperature

#### Cause

Shows temperature measurement fault for option board OPTBH or OPTB8.

- Temperature exceeded set limit.
- Sensor disconnected.
- Short circuit.

#### Troubleshooting

Find the cause of temperature rise.

### 12.10.126 Fault 57 - Identification

#### Cause

Identification run has failed.

This fault is type A fault (Alarm).

#### Troubleshooting

- Run command was removed before completion of identification run.
- The motor is not connected to the AC drive.
- There is load on motor shaft.

### 12.10.127 Fault 58 - Brake

#### Cause

Actual status of the brake is different from the control signal.

It is possible to set different responses in the application for this fault. See parameter group Protections.

#### Troubleshooting

Do a check of the mechanical brake state and connections.

### 12.10.128 Fault 59 - Follower communication

#### Cause

SystemBus or CAN communication is broken between Master and Follower.

#### Troubleshooting

- Do a check of the option board parameters.
- Do a check of the optical fiber cable or CAN cable.

### 12.10.129 Fault 60 - Cooling

#### Cause

External cooling has failed.

Normally this fault comes from the heat exchanger unit.

#### Troubleshooting

Do a check of the reason for the failure on the external system.

### 12.10.130 Fault 61 - Speed error

#### Cause

Motor speed is unequal to reference.

**Troubleshooting**

- Do a check of the encoder connection.
- PMS motor has exceeded the pull-out torque.

**12.10.131 Fault 62 - Run disable****Cause**

Run enable signal is low.

**Troubleshooting**

Do a check of the reason for the Run enable signal.

**12.10.132 Fault 63 - Quick stop****Cause**

Command for quick stop received from digital input or fieldbus.

This fault is type A fault (Alarm).

**Troubleshooting**

Reset the fault.

**12.10.133 Fault 64 - Input switch open****Cause**

Drive input switch is open.

This fault is type A fault (Alarm)

**Troubleshooting**

Do a check of the main power switch of the drive.

**12.10.134 Fault 65 - Measured Temperature****Cause**

Shows temperature measurement fault for option board OPTBH or OPTB8.

- Temperature exceeded set limit.
- Sensor disconnected.
- Short circuit.

### Troubleshooting

Find the cause of temperature rise or sensor malfunction.

#### 12.10.135 Fault 70 - Active filter fault

##### Cause

Fault triggered by digital input (see param. P2.2.7.33).

It is possible to set different responses in the application for this fault. See parameter group Protections.

### Troubleshooting

Remove fault situation on active filter.

#### 12.10.136 Fault 74 - Follower fault

##### Cause

When using normal Master Follower function this fault code is given if one or more follower drives trips to fault.

### Troubleshooting

Correct the fault cause on follower and reset fault.

## Index

+		Debug menu .....	96
+24 V control voltage output .....	61	Default page .....	89
+24 V DC external power .....	59	Derating .....	30
<b>A</b>		Digital input signal inversion .....	62
Accessories bag .....	27	Dimensions, flange mounting FI7–FI8 .....	112
Active faults menu .....	76	Dimensions, flange mounting FR4–FR6 .....	110
Application information .....	95	Dimensions,FI4-FI8 .....	109
Application selection .....	82	Display indications .....	23
Approvals and certifications .....	8	Display, backlight .....	90
Automatic parameter back-up .....	84	Display, contrast .....	90
		Disposal .....	8
		Down from keypad .....	84
<b>B</b>		<b>E</b>	
Block diagram .....	15	EMC class .....	22
		EMC-compliant installation .....	39
<b>C</b>		Enclosure size .....	20
Cable accessories .....	49, 52, 55	Environment requirements .....	30
Cable requirements .....	37, 37, 38	Expander board menu .....	96
Cable sizes .....	115, 116	Expander boards page .....	95
Cable stripping .....	116	External controller .....	16
Cables, distance between .....	49		
Capacitors, reforming of .....	104	<b>F</b>	
Changing the rotation direction .....	75	Fan control .....	91
Commissioning .....	99	Fault history menu .....	78
Commissioning, checks after .....	101	Fault time data record .....	77, 77
Commissioning, safety .....	98	Fault types .....	106
Control cable .....	60	Faults .....	106
Control mode .....	74	Faults, resetting of .....	106
Control mode, keypad .....	76	Fuse .....	37, 38, 38
Control panel .....	68	Fuse sizes .....	114, 115
Control terminals, OPTA1 .....	61	<b>G</b>	
Control terminals, OPTA2 .....	64	Galvanic isolation barriers .....	66
Control terminals, OPTA3 .....	64	Grounding principle .....	38
Control unit components .....	59		
Cooling .....	32	<b>H</b>	
Cooling space .....	32	Hardware information .....	95
Copy parameters .....	83	Hardware settings menu .....	90
Copying frequency reference set .....	76	High altitude installation .....	31
Covers, tightening torques .....	118	High overload .....	119
		HMI acknowledge timeout .....	92
<b>D</b>			
DC currents .....	125, 125		
DC link capacitance .....	126		

<b>I</b>	
Installation environment .....	30
Installing the Cables, FR4-FR6 .....	49
Installing the Cables, FR7/FI7 .....	52
Installing the Cables, FR8/FI8 .....	55
Insulation checks .....	100
Intended use .....	16
Internal brake resistor connection .....	91
<b>J</b>	
Jumper selections, OPTA1 .....	63
<b>K</b>	
Keypad .....	22
Keypad control menu .....	73
Keypad control parameters .....	74
Keypad settings menu .....	89
<b>L</b>	
Language selection .....	82
Lifting the product .....	28
Low overload .....	118
<b>M</b>	
Maintenance .....	104
Menu structure .....	24
Monitored values .....	69
Monitoring menu .....	68
Motor overload protection .....	16
Motor run checklist .....	103
Motor status .....	16
Multimonitoring items .....	88
<b>O</b>	
Option boards .....	59, 66, 95, 96
Overload capability .....	118
<b>P</b>	
Package label .....	17
Parameter lock .....	87
Parameter menu .....	70
Parameter set, saving .....	83
Parameter, comparing .....	85
Parameter, downloading to drive .....	84
Parameter, editing .....	71, 72
Parameter, uploading to control panel .....	84
Password .....	86
Power ratings .....	120, 120
Pre-charge Mode parameter .....	93
Principal connection diagram .....	36
Product modified label .....	28
Purpose of the manual .....	8
<b>Q</b>	
Qualified personnel .....	8
<b>R</b>	
Remote commands .....	16
Resetting fault history .....	79
RUN test .....	102
<b>S</b>	
Safety .....	11, 13
Security menu .....	86
Service Info file .....	107
Sine filter parameter .....	93
Software information .....	94
Start up quick guide .....	9
Start-up test .....	102
Start-up wizard .....	88
Stop motor function .....	75
Storage .....	28
Surveillance .....	16
Symbols .....	11
System feedback .....	16
System info menu .....	93
System menu .....	79
System menu functions .....	79
<b>T</b>	
Technical data .....	121
Terminals, FR4/FI4 .....	40
Terminals, FR6/FI6 .....	42
Terminals, FR7/FI7 .....	44
Terminals, FR8/FI8 .....	46
Terminals, tightening torques .....	118
Timeout time .....	90
Total counters .....	93
Trip counters .....	94
Type code .....	18

**U**

UL certification .....	8
UL requirements, cables .....	37
Up to keypad .....	84

**V**

Vibration and shock .....	30
---------------------------	----

**W**

Weight .....	108
--------------	-----







ENGINEERING  
TOMORROW

*Danfoss*

.....  
Danfoss can accept no responsibility for possible errors in catalogues, brochures and other printed material. Danfoss reserves the right to alter its products without notice. This also applies to products already on order provided that such alterations can be made without subsequential changes being necessary in specifications already agreed. All trademarks in this material are property of the respective companies. Danfoss and the Danfoss logotype are trademarks of Danfoss A/S. All rights reserved.  
.....

HSLUk' >V  
? V\ TWdaXfZWDanfoss Group  
Runsorintie 7  
65380 Vaasa  
Finland  
drives.danfoss.com

