

VLT® C-option Adapter MCF 107

1 Introduction

1.1 Product Overview

The VLT® C-option Adapter MCF 107 extends the number of B options that can be installed in a VLT® AutomationDrive FC 302.

The following drives support the MCF 107 option:

- VLT® AutomationDrive FC 302, enclosure sizes A5, B1, and B2.

The MCF 107 option is supported from firmware version 8.43.

Normally, a drive can be fitted with 1 A option and 1 B option in the A- and B-slots on the control card. With the MCF 107, it is possible to have 2 different B options installed. One in the standard B-slot and 1 in the MCF 107. However, when 2 B options are installed, it is not possible to have any fieldbus options (A options) installed.

The following options are supported in the standard B-slot:

- VLT® Encoder Option MCB 102.
- VLT® Resolver Option MCB 103.
- VLT® Safe PLC I/O MCB 108.

The following options are supported in the MCF 107:

- VLT® PTC Thermistor Card MCB 112.

1.2 Order Numbers

Table 1: Order Numbers

Option	Uncoated	Coated
VLT® C-option Adapter MCF 107	134B7093	–
VLT® Encoder Option MCB 102	130B1115	130B1203
VLT® Resolver Option MCB 103	130B1127	130B1227
VLT® Safe PLC I/O MCB 108	130B1120	130B1220
VLT® PTC Thermistor Card MCB 112	–	130B1137

1.3 Items Supplied

The following items are supplied:

- VLT® C-option Adapter MCF 107
- Ribbon cable
- 2 x Torx 10 screws
- Installation Guide

1.4 Tools Required

The following tools are required for installing the VLT® C-option Adapter MCF 107:

- Torx 10 screwdriver
- Flat-head screwdriver

2 Safety

2.1 Safety Instructions

⚠ WARNING ⚠

DISCHARGE TIME

The drive contains DC-link capacitors, which can remain charged even when the drive is not powered. High voltage can be present even when the warning indicator lights are off.

Failure to wait the specified time after power has been removed before performing service or repair work could result in death or serious injury.

- Stop the motor.
- Disconnect AC mains, permanent magnet type motors, and remote DC-link supplies, including battery back-ups, UPS, and DC-link connections to other drives.
- Wait for the capacitors to discharge fully. The minimum waiting time is specified in the table *Discharge time* and is also visible on the nameplate on top of the drive.
- Before performing any service or repair work, use an appropriate voltage measuring device to make sure that the capacitors are fully discharged.

Table 2: Discharge Time

Voltage [V]	Minimum waiting time (minutes)			
	4	7	15	20
200–240	0.25–3.7 kW (0.34–5.0 hp)	–	5.5–37 kW (7.5–50 hp)	–
380–500	0.25–7.5 kW (0.34–10 hp)	–	11–75 kW (15–100 hp)	90–200 kW (150–350 hp)
400	–	–	–	90–315 kW (125–450 hp)
500	–	–	–	110–355 kW (150–450 hp)
525	–	–	–	55–315 kW (75–400 hp)
525–600	0.75–7.5 kW (1.0–10 hp)	–	11–75 kW (15–100 hp)	–
525–690	–	1.5–7.5 kW (2.0–10 hp)	11–75 kW (15–100 hp)	37–315 kW (50–450 hp)
690	–	–	–	55–315 kW (75–400 hp)

3 Installation

3.1 Overview

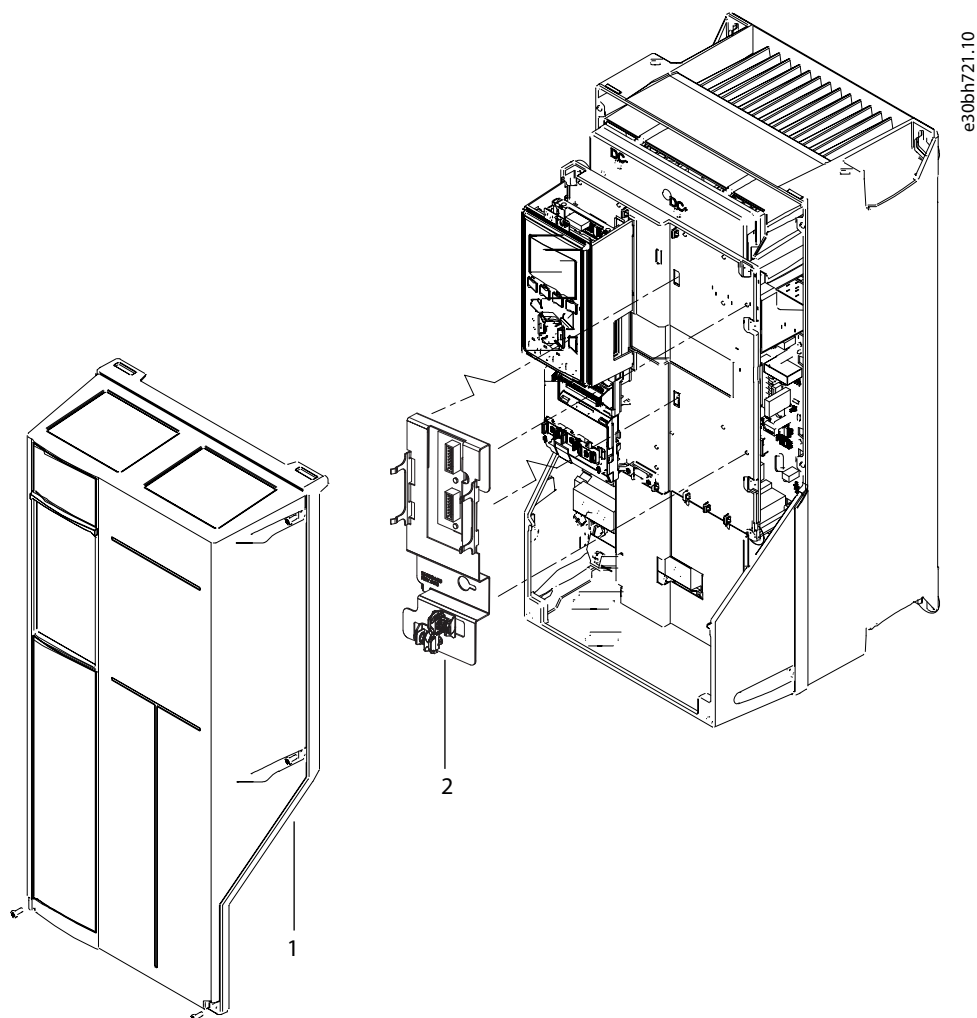

1 Front cover

2 VLT® C-option Adapter MCF 107

Illustration 1: Location of the MCF 107 Option

3.2 Installing the MCF 107

Context:

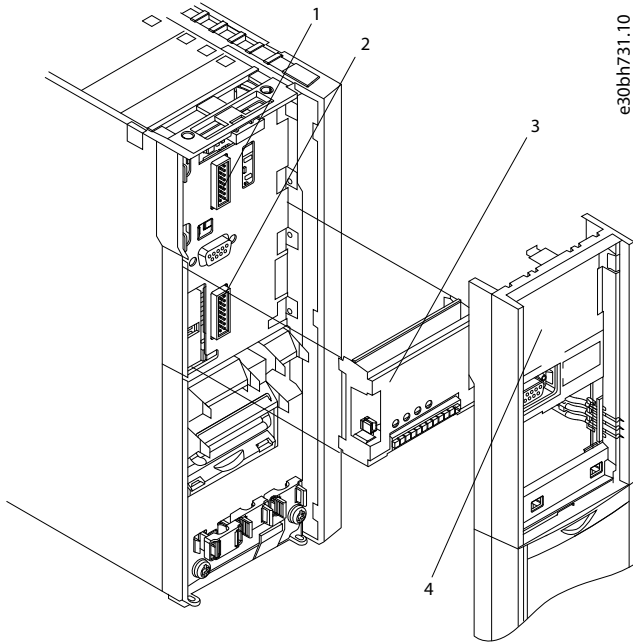

<p>1 Location of A options</p>	<p>2 Location of B options</p>
<p>3 B option</p>	<p>4 LCP frame</p>

Procedure

1. Disconnect power to the drive.
2. Disconnect power to the live part connections on the relay terminals.
3. Remove the LCP or the blind cover.
4. Remove the terminal cover.
5. Remove the control cables.
6. Remove the front cover.
7. Remove the LCP cradle.

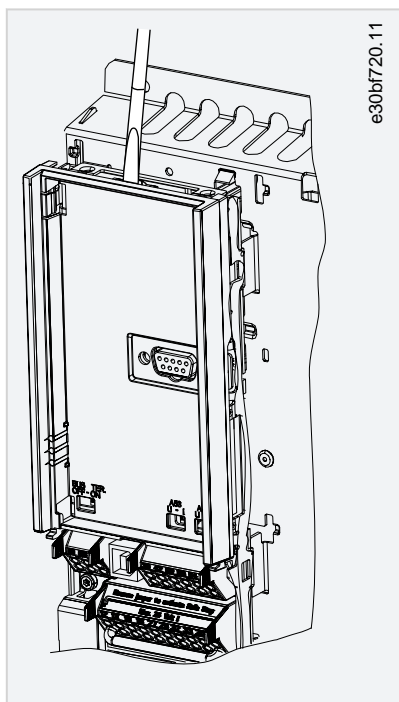

8. Remove all control cables from the metal bracket (spring-loaded).
9. Install the VLT® C-option Adapter MCF 107.

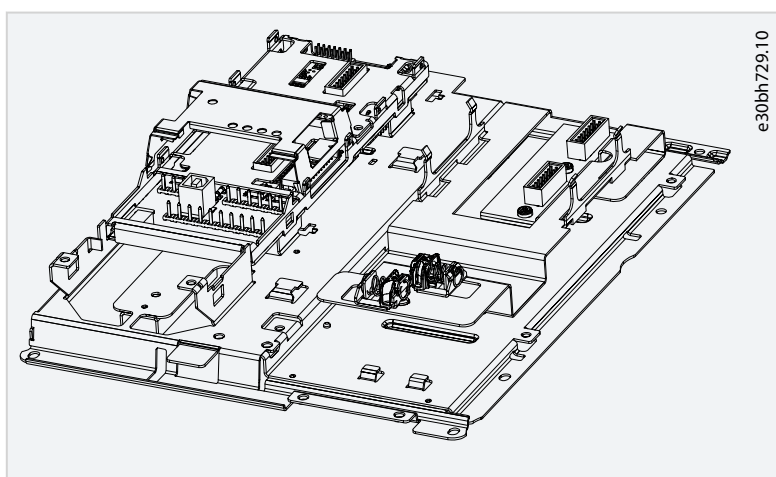

10. Tighten the 2 T10 screws (marked with circles in the following illustration). Tightening torque is 1.5 Nm (13.27 in-lb).

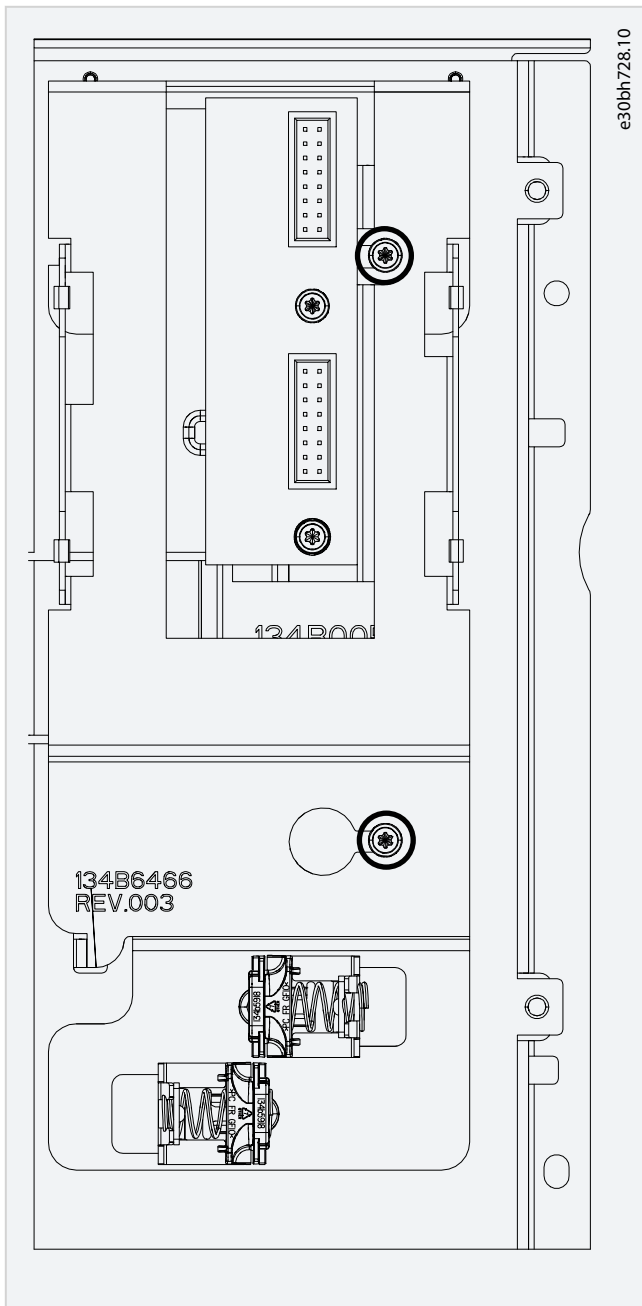

11. Connect 1 end of the ribbon cable in the A-option slot and the other end in the upper slot in the MCF 107.

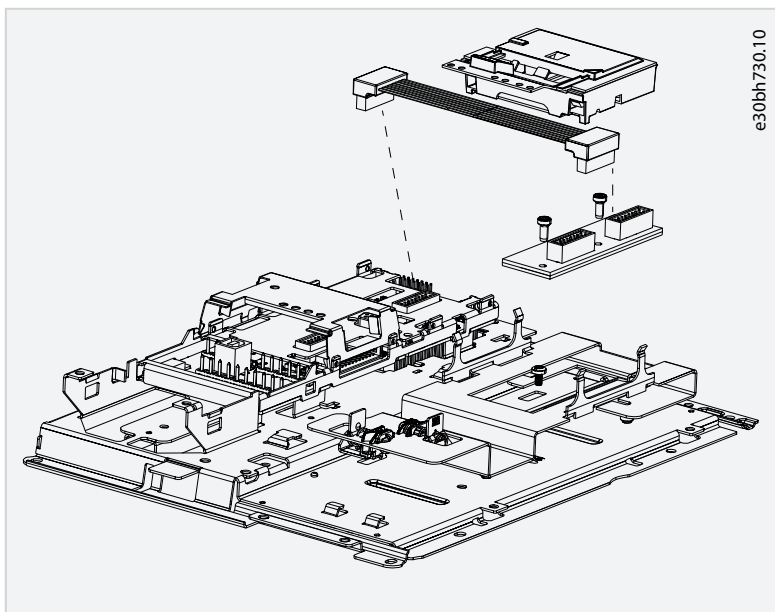

e30bh730.10

12. Install the VLT® PTC Thermistor Card MCB 112 option in the option holder and plug on the MCF 107.

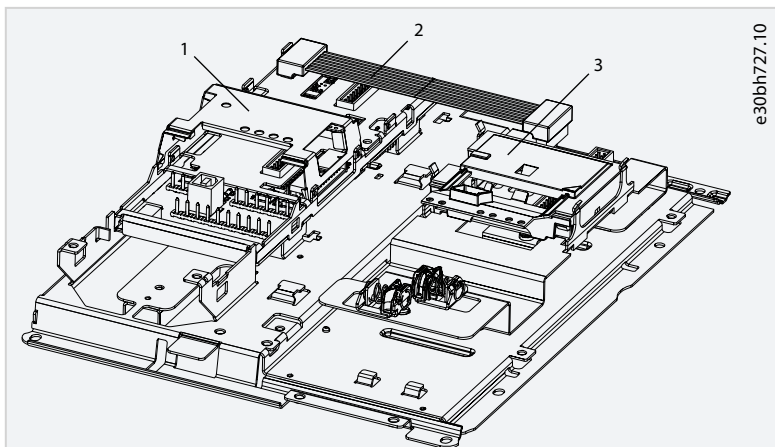

e30bh727.10

- 1 VLT® PTC Thermistor Card MCB 112
- 3 Encoder or resolver option

- 2 Ribbon cable

.....
 Danfoss can accept no responsibility for possible errors in catalogues, brochures and other printed material. Danfoss reserves the right to alter its products without notice. This also applies to products already on order provided that such alterations can be made without subsequential changes being necessary in specifications already agreed. All trademarks in this material are property of the respective companies. Danfoss and the Danfoss logotype are trademarks of Danfoss A/S. All rights reserved.

Danfoss A/S
 Ulsnaes 1
 DK-6300 Graasten
 vlt-drives.danfoss.com

