

# VLT® Connection Kit for MCA 12x Options

## 1 Introduction

### 1.1 Purpose of the Connection Kit

Use the VLT® Connection Kit for MCA 12x Options for ensuring Ethernet cable access via the bottom of the drive. This is sometimes required for IP54 (NEMA Type 12), IP55 (NEMA Type 12), and IP66 (NEMA 4X) drives.

### 1.2 Compatible Drives

The VLT® Connection Kit for MCA 12x Options is compatible with the following drives:

- VLT® HVAC Drive FC 102
- VLT® Refrigeration Drive FC 103
- VLT® AQUA Drive FC 202
- VLT® AutomationDrive FC 301/FC 302

### 1.3 Items Supplied

The kit contains the following items:

- VLT® Connection Kit for MCA 12x Options
- 2 x Ethernet extension cables
- 2 x Torx 10 screws
- Installation Guide

### 1.4 Tools Required

The following tools are required for installing the VLT® Connection Kit for MCA 12x Option:

- Torx 10 screwdriver
- Flat-head screwdriver

## 2 Safety

### 2.1 Safety Instructions

#### ⚠ WARNING ⚠

##### DISCHARGE TIME

The drive contains DC-link capacitors, which can remain charged even when the drive is not powered. High voltage can be present even when the warning indicator lights are off.

Failure to wait the specified time after power has been removed before performing service or repair work could result in death or serious injury.

- Stop the motor.
- Disconnect AC mains, permanent magnet type motors, and remote DC-link supplies, including battery back-ups, UPS, and DC-link connections to other drives.
- Wait for the capacitors to discharge fully. The minimum waiting time is specified in the table *Discharge time* and is also visible on the nameplate on the top of the drive.
- Before performing any service or repair work, use an appropriate voltage measuring device to make sure that the capacitors are fully discharged.

Table 1: Discharge Time

Voltage [V]	Minimum waiting time (minutes)					
	4	7	15	20	30	40
244–240	0.25–3.7 kW (0.34–5.0 hp)	–	5.5–37 kW (7.5–50 hp)	–	–	–
380–500	0.25–7.5 kW (0.34–10 hp)	–	11–75 kW (15–100 hp)	90–200 kW (125–300 hp)	250–500 kW (350–650 hp)	250–800 kW (350–1075 hp) 315–500 kW (450–650 hp)
400	–	–	–	90–315 kW (125–450 hp)	–	–
500	–	–	–	110–355 kW (150–500 hp)	–	–
525	–	–	–	55–315 kW (75–450 hp)	–	–
525–600	0.75–7.5 kW (1.0–10 hp)	–	11–75 kW (15–100 hp)	–	–	–
525–690	–	1.5–7.5 kW (2.0–10 hp)	11–75 kW (15–100 hp)	37–315 kW (50–450 hp)	355–1200 kW (500–1600 hp)	355–2000 kW (500–2700 hp) 355–710 kW (500–950 hp)
690	–	–	–	55–315 kW (75–450 hp)	–	–

### 3 Installation

#### 3.1 Installation Overview

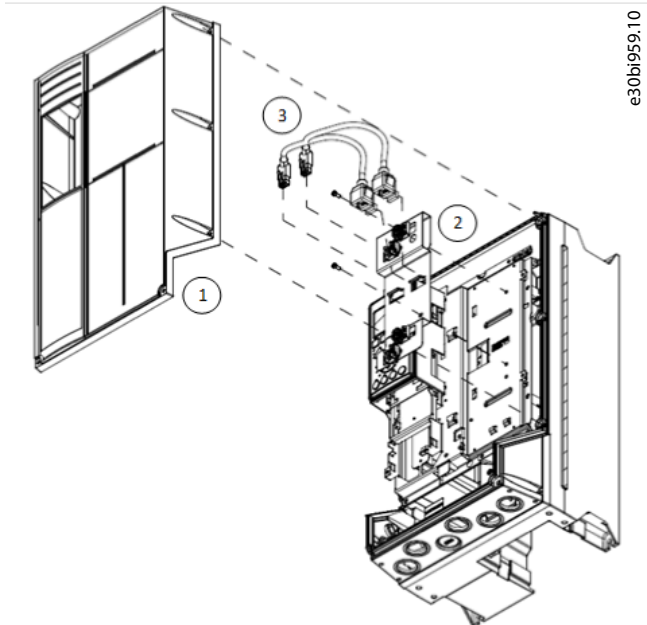

Illustration 1: Front Cover, Drive, and Option Kit

1	Front cover	3	Ethernet extension cables
2	Optional sheet metal		

#### 3.2 Installing the VLT® Connection Kit for MCA 12x Options

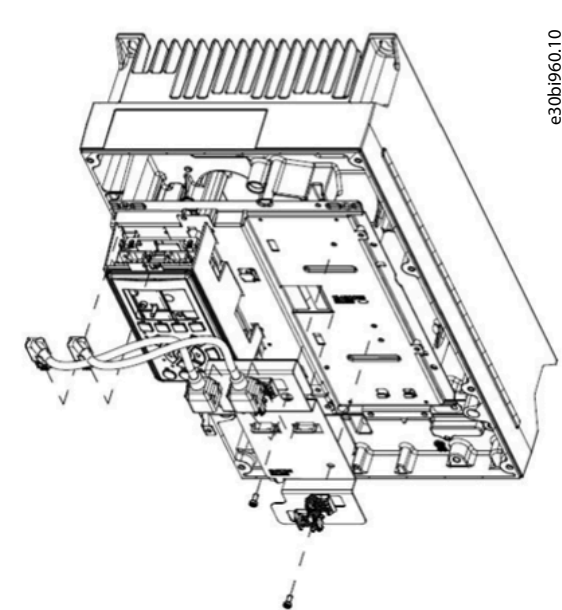
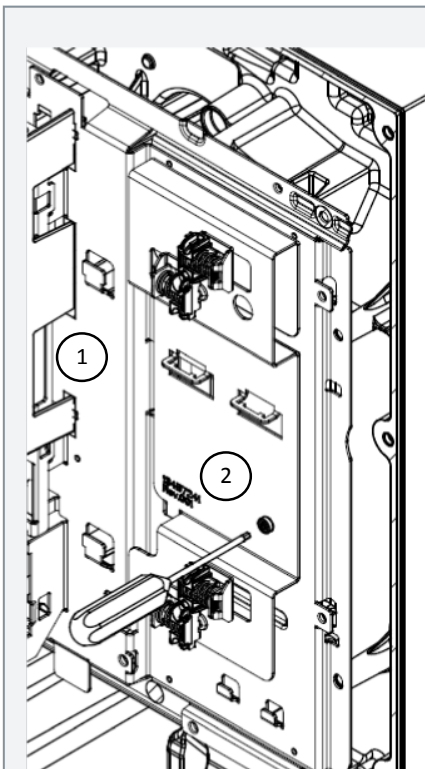

Illustration 2: Location of the VLT® Connection Kit for MCA 12x Options

#### Procedure

1. Disconnect power to the drive.
2. Disconnect power to the live part connections on the relay terminals.

3. Remove the front cover.
4. Install the option steel plate on the control plate of the drive.



- |   |                    |
|---|--------------------|
| 1 | Control plate      |
| 2 | Option steel plate |

5. Tighten the 2 T10 screws to 1.2 Nm (10.62 in-lb)

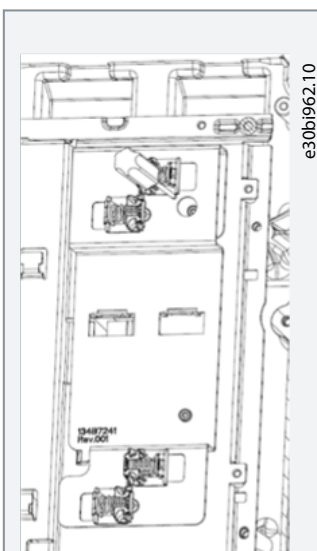

6. Connect the cables to the option steel plate and click the cables into the cable hooks.

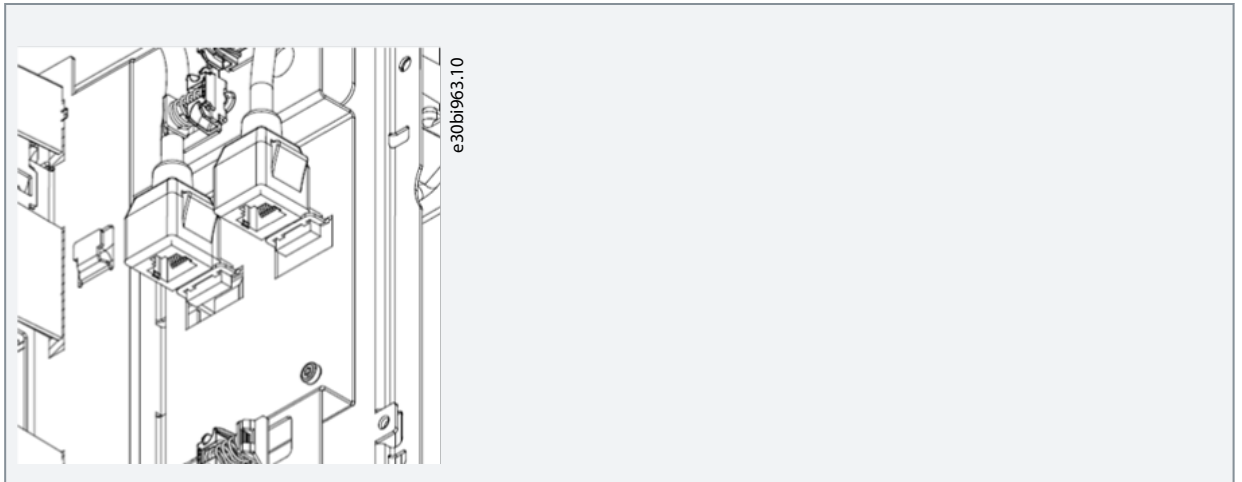

7. Connect the Ethernet cables to the Ethernet option card and click the cables into the cable hooks.

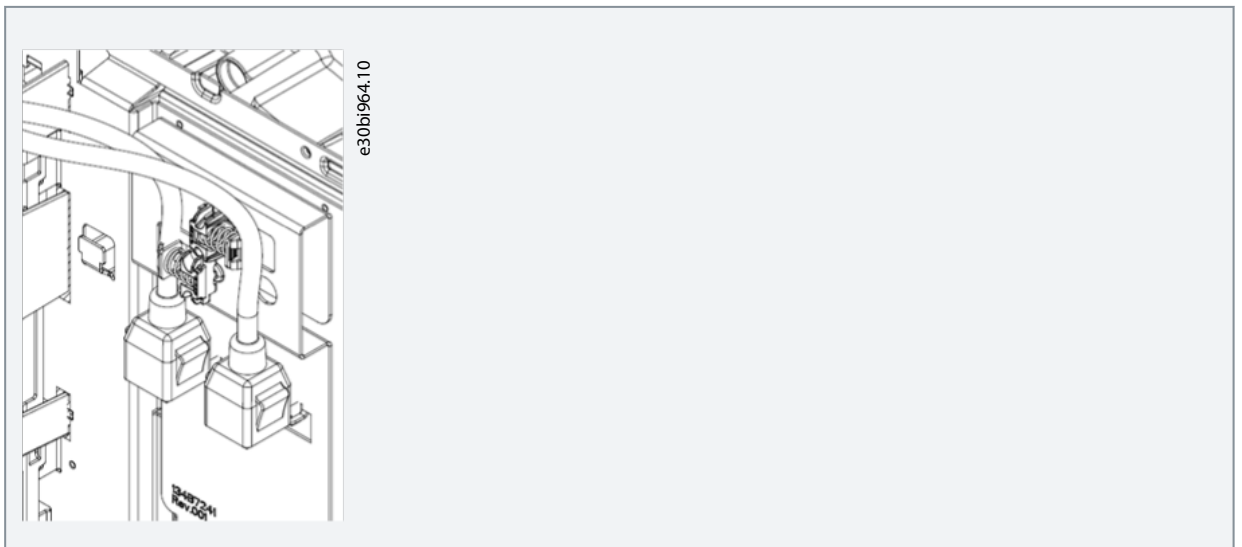

8. Connect the external Ethernet cable to the internal extensions cables on the option.

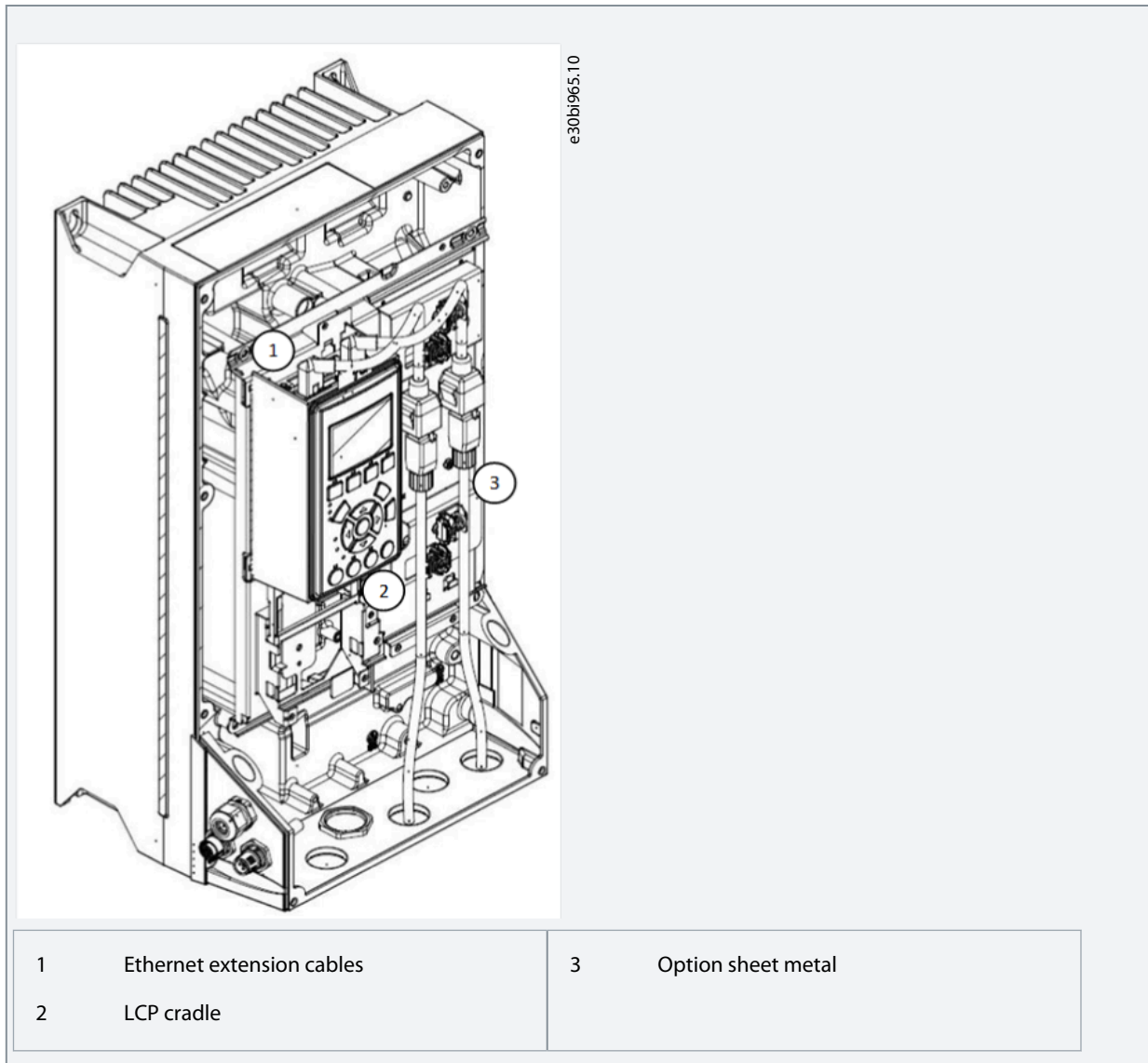

**Danfoss A/S**  
 Ulsnaes 1  
 DK-6300 Graasten  
[vlt-drives.danfoss.com](http://vlt-drives.danfoss.com)

Danfoss can accept no responsibility for possible errors in catalogs, brochures and other printed material. Danfoss reserves the right to alter its products without notice. This also applies to products already on order provided that such alterations can be made without subsequential changes being necessary in specifications already agreed. All trademarks in this material are property of the respective companies. Danfoss and the Danfoss logotype are trademarks of Danfoss A/S. All rights reserved.

