

Operating Guide

VLT® Extended Relay Card MCB 113

VLT® HVAC Drive FC 102, VLT® Refrigeration

Drive FC 103, VLT® AQUA Drive FC 202, VLT® Au-  
tomationDrive FC 301/FC 302





## Contents

<b>1</b>	<b>Introduction</b>	<b>5</b>
1.1	Purpose of this Operating Guide	5
1.2	Trademarks	5
1.3	Document Version	5
1.4	Additional Resources	5
1.5	Product Overview	5
1.5.1	Intended Use	5
1.6	Type Approvals and Certifications	6
<b>2</b>	<b>Safety</b>	<b>8</b>
2.1	Safety Precautions	8
<b>3</b>	<b>Installation</b>	<b>10</b>
3.1	Mechanical Installation	10
3.1.1	Installation in Enclosure Sizes A5–C4	10
3.2	Electrical Installation	10
3.2.1	Safety Instructions	10
3.2.2	Wiring Schematic	11
3.2.3	Wiring Schematic - Following NAMUR	13
3.2.4	Galvanic Isolation	13
<b>4</b>	<b>Parameter Setup</b>	<b>15</b>
4.1	Introduction to Parameter Setup	15
4.2	5-** Digital In/Out	15
4.2.1	Parameter Group 5-1* Digital Inputs	15
4.2.2	Parameter Group 5-2* Digital Inputs	31
4.2.3	Parameter Group 5-3* Digital Outputs	32
4.2.4	Parameter Group 5-4* Relays	38
4.3	6-** Analog Outputs	43
4.3.1	6-7* Analog Output 3 MCB 113	43
4.3.2	6-8* Analog Output 4 MCB 113	45
4.4	14-** 24 V DC External Supply	46
4.4.1	14-8* Options	46
4.5	16-** Data Readouts	47
4.5.1	16-6* Inputs and Outputs	47
<b>5</b>	<b>Specifications</b>	<b>50</b>
5.1	Relays	50
5.2	Digital Inputs	50
5.3	Analog Outputs	50

---

5.4	EMC	50
<b>6</b>	<b>Appendix</b>	<b>51</b>
6.1	Abbreviations	51
6.2	Conventions	51

---

# 1 Introduction

## 1.1 Purpose of this Operating Guide

This Operating Guide provides information for safe installation and setup of a VLT® Extended Relay Card MCB 113 option used in the VLT® FC drive series.

The Operating Guide is intended for use by qualified personnel only. Personnel must be familiar with the VLT® FC drive series.

Read and follow the instructions before installation and setup, and ensure that instructions for safe installation and setup are observed. Always keep these instructions available with the drive.

## 1.2 Trademarks

VLT® is a registered trademark for Danfoss A/S.

## 1.3 Document Version

This operating guide is regularly reviewed and updated. All suggestions for improvement are welcome. See document version and changes applied in [table 1](#).

The original language of this manual is English.

**Table 1: Version and Changes Applied**

Document version	Remarks
AQ322553864968, version 0101	Option now also applicable for VLT® HVAC Drive FC 102, VLT® Refrigeration Drive FC 103, and VLT® AQUA Drive FC 202.

## 1.4 Additional Resources

More information resources are available to understand advanced drive functions and programming.

- The VLT® FC Series Operating Guides provide information required to install and commission the drive for given applications.
- The VLT® FC Series Programming Guides provide greater detail on working with parameters.
- VLT® FC Series Design Guides provide detailed capabilities and functionality to design motor control systems for various applications.

Technical documentation for other product options is available at [www.danfoss.com](http://www.danfoss.com).

## 1.5 Product Overview

### 1.5.1 Intended Use

The VLT® Extended Relay Card MCB 113 is exclusively intended for use in option slot C1. The option is constructed as a standard C1 option compatible with the following VLT® FC Series:

- VLT® HVAC Drive FC 102
- VLT® Refrigeration Drive FC 103
- VLT® AQUA Drive FC 202
- VLT® AutomationDrive FC 301/FC 302.

The MCB 113 adds 7 digital inputs, 2 analog outputs, and 4 SPDT relays to the standard I/O of the drive. These additions make it possible to comply with the German NAMUR NE37 recommendations.

When ordered with the drive, the option is installed from factory. For ordering, use the following order numbers:

- 130B1164 (Non-coated)
- 130B1264 (Coated)

For retrofit, a mounting kit must be purchased. The mounting kit includes a fan for VLT® Motion Control MCO 305 and is only to be mounted if MCO 305 is used.

**Table 2: Mounting Kits for Book-style Enclosures**

Enclosure sizes	Order number
A2 and A3 (40 mm for 1 C option)	130B7530
A2 and A3 (60 mm for C0 + C1 option)	130B7531
B3 (40 mm for 1 C option)	130B1413
B3 (60 mm for C0 + C1 option)	130B1414

**Table 3: Mounting Kits for Compact Enclosures**

Enclosure size	Order number
A5	130B7532
B (except B3), C, D, E, and F	130B7533

## 1.6 Type Approvals and Certifications

The following list is a selection of possible type approvals and certifications for Danfoss drives:

**NOTICE**

The specific approvals and certification for the drive are on the nameplate of the drive. For more information, contact the local Danfoss office or partner.

## 2 Safety

### 2.1 Safety Precautions

**⚠ WARNING ⚠**

**HIGH VOLTAGE**

AC drives contain high voltage when connected to AC mains input, DC supply, or load sharing. Failure to perform installation, start-up, and maintenance by qualified personnel can result in death or serious injury.

- Only qualified personnel must perform installation, start-up, and maintenance.

**⚠ WARNING ⚠**

**UNINTENDED START**

When the drive is connected to the AC mains, DC supply, or load sharing, the motor may start at any time, causing risk of death, serious injury, and equipment or property damage. The motor may start by activation of an external switch, a fieldbus command, an input reference signal from the LCP or LOP, via remote operation using MCT 10 Set-up software, or after a cleared fault condition.

- Press [Off] on the LCP before programming parameters.
- Disconnect the drive from the mains whenever personal safety considerations make it necessary to avoid unintended motor start.
- Check that the drive, motor, and any driven equipment are in operational readiness.

**⚠ WARNING ⚠**

**DISCHARGE TIME**

The drive contains DC-link capacitors, which can remain charged even when the drive is not powered. High voltage can be present even when the warning indicator lights are off.

Failure to wait the specified time after power has been removed before performing service or repair work could result in death or serious injury.

- Stop the motor.
- Disconnect AC mains, permanent magnet type motors, and remote DC-link supplies, including battery back-ups, UPS, and DC-link connections to other drives.
- Wait for the capacitors to discharge fully. The minimum waiting time is specified in the table *Discharge time* and is also visible on the nameplate on top of the drive.
- Before performing any service or repair work, use an appropriate voltage measuring device to make sure that the capacitors are fully discharged.

**Table 4: Discharge Time, VLT® HVAC Drive FC 102 and VLT® Refrigeration Drive FC 103**

Voltage [V]	Minimum waiting time (minutes)		
	4	7	15
200–240	1.1–3.7 kW (1.5–5 hp)	–	5.5–45 kW (7.5–60 hp)
380–480	1.1–7.5 kW (1.5–10 hp)	–	11–90 kW (15–125 hp)
525–600	1.1–7.5 kW (1.5–10 hp)	–	11–90 kW (15–125 hp)



Voltage [V]	Minimum waiting time (minutes)		
525–690	–	1.1–7.5 kW (1.5–10 hp) (FC 102 only)	11–90 kW (15–125 hp) (FC 102 only)

**Table 5: Discharge Time, VLT® AQUA Drive FC 202**

Voltage [V]	Minimum waiting time (minutes)		
	4	7	15
200–240	0.25–3.7 kW (0.34–5 hp)	–	5.5–45 kW (7.5–60 hp)
380–480	0.37–7.5 kW (0.5–10 hp)	–	11–90 kW (15–125 hp)
525–600	0.75–7.5 kW (1.0–10 hp)	–	11–90 kW (15–125 hp)
525–690	–	1.1–7.5 kW (1.5–10 hp)	11–90 kW (15–125 hp)

**Table 6: Discharge Time, VLT® AutomationDrive FC 301/FC 302**

Voltage [V]	Minimum waiting time (minutes)		
	4	7	15
200–240	0.25–3.7 kW (0.34–5 hp)	–	5.5–37 kW (7.5–50 hp)
380–500	0.25–7.5 kW (0.34–10 hp)	–	11–75 kW (15–100 hp)
525–600	0.75–7.5 kW (1–10 hp)	–	11–75 kW (15–100 hp)
525–690	–	1.5–7.5 kW (2–10 hp)	11–75 kW (15–100 hp)

**⚠ WARNING ⚠**

**LEAKAGE CURRENT HAZARD**

Leakage currents exceed 3.5 mA. Failure to ground the drive properly can result in death or serious injury.

- Ensure the correct grounding of the equipment by a certified electrical installer.

**⚠ WARNING ⚠**

**ROTATING SHAFTS**

Contact with rotating shafts and electrical equipment can result in death or serious injury.

- Ensure that only trained and qualified personnel perform installation, start-up, and maintenance.
- Ensure that electrical work conforms to national and local electrical codes.
- Follow the procedures in this guide.

## 3 Installation

### 3.1 Mechanical Installation

#### 3.1.1 Installation in Enclosure Sizes A5–C4

#### NOTICE

For enclosure sizes A5–C4, only 1 C option can be installed at the time.

#### NOTICE

Do not mount the small fan for VLT® Extended Relay Card MCB 113, VLT® A/B in C Option Adapter MCF 106, or enclosure sizes B4, C3, C4, D, E, and F.

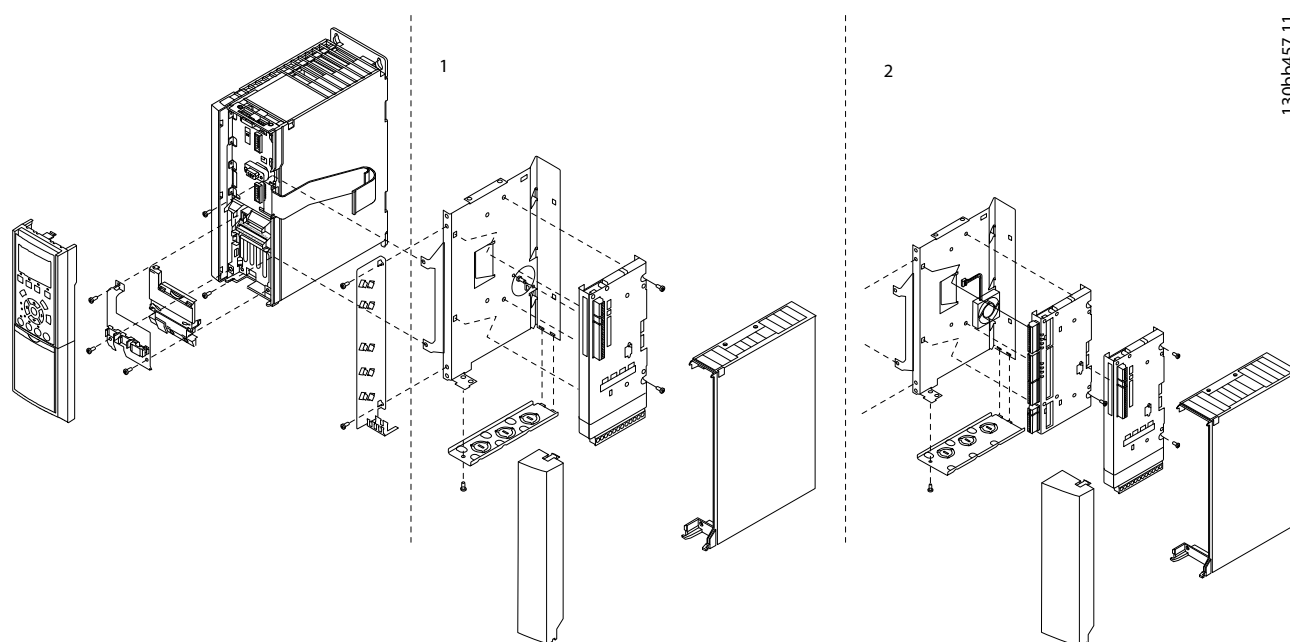

**Illustration 1: Installation of VLT® Extended Relay Card MCB 113 - Exploded View**

- If only 1 C option is used, use the 40 mm mounting kit.
- If the MCB 113 is used with VLT® Motion Control MCO 305, use the 60 mm mounting kit.

### 3.2 Electrical Installation

#### 3.2.1 Safety Instructions

See [2.1 Safety Precautions](#) for general safety instructions.

### 3.2.2 Wiring Schematic

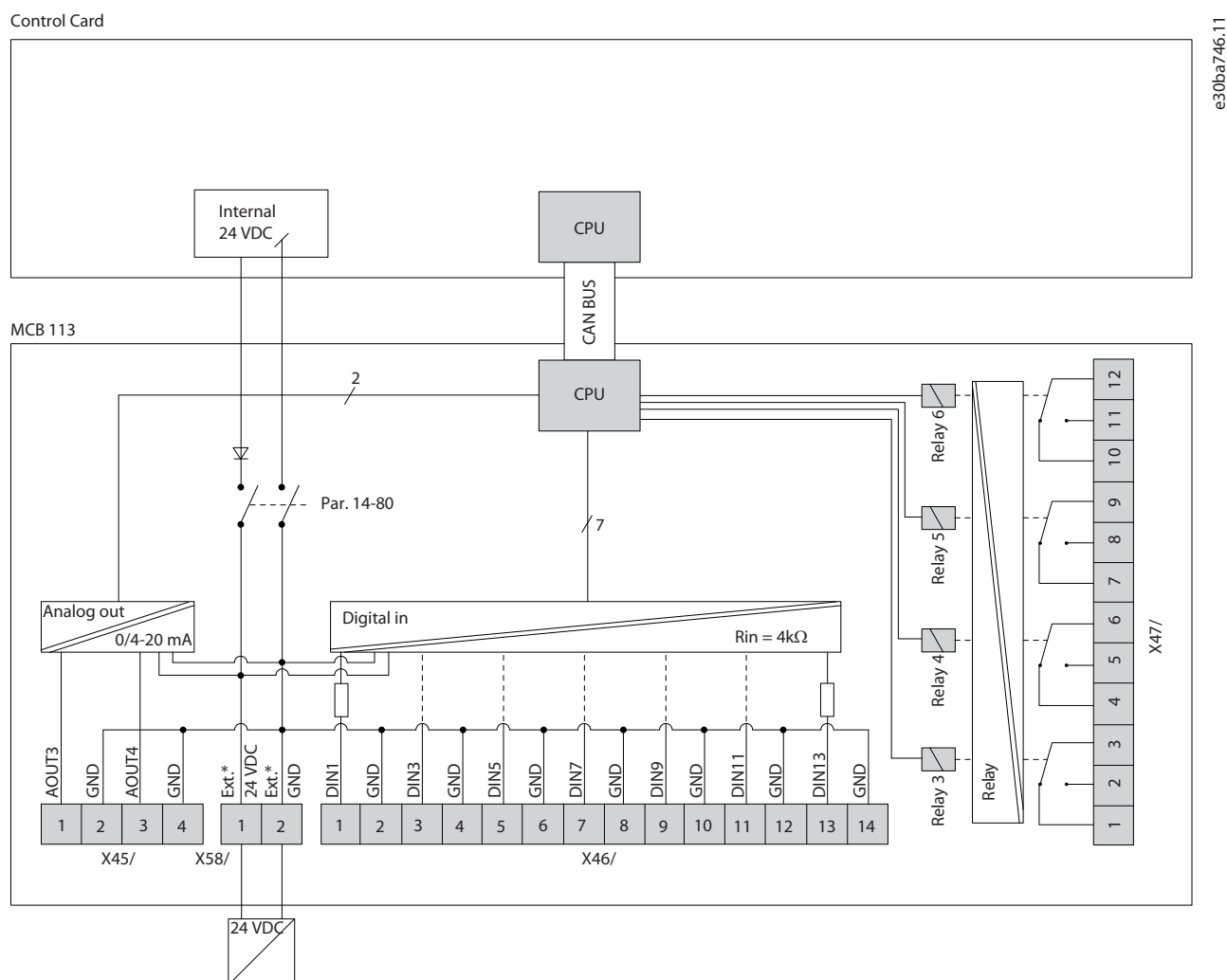

e30ba746.11

#### NOTICE

The connections of these relays differ from the standard relays of the drives. The coil is between T2 and T3 and not between T1 and T2.

Digital inputs are programmed for either PNP or NPN in *parameter 5-00 Digital I/O Mode*.

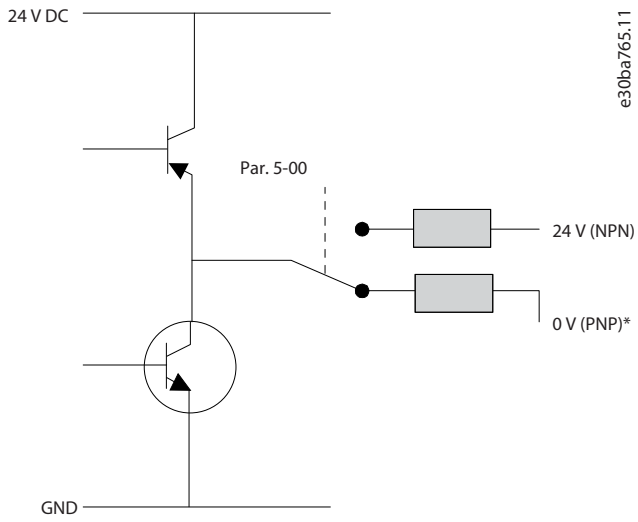
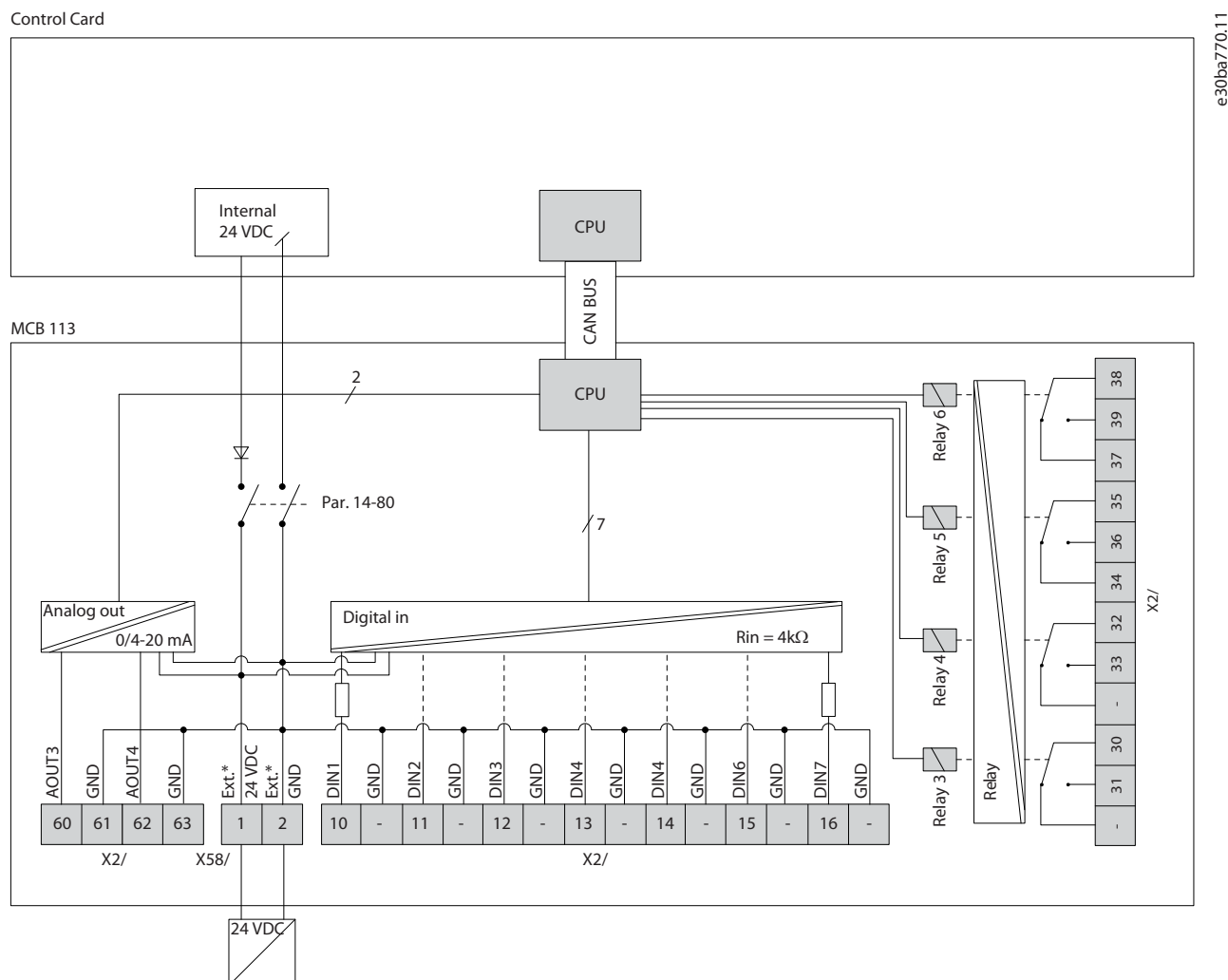

Illustration 3: Programming Digital Inputs

### 3.2.3 Wiring Schematic - Following NAMUR



### 3.2.4 Galvanic Isolation

The VLT® Extended Relay Card MCB 113 can be connected to an 24 V external supply on X58/ to ensure galvanic isolation between the drive and the option card. If galvanic isolation is not needed, the option card can be supplied through internal 24 V from the drive. The internal 24 V supply is available on X58 if *parameter 14-80 Option Supplied by External 24VDC* is set to [0] No.

The relays support a combination of 24 V and 250 V signals as long as there is an unused relay in between.

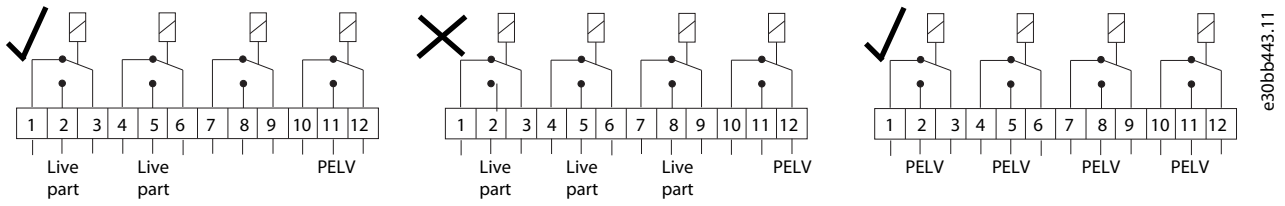

Illustration 5: Valid Connections for Galvanic Isolation

## 4 Parameter Setup

### 4.1 Introduction to Parameter Setup

The parameters included in this Operating Guide are extracts from the drive-specific programming guides. Refer to these Programming Guides for full parameter descriptions.

### 4.2 5-\*\* Digital In/Out

#### 4.2.1 Parameter Group 5-1\* Digital Inputs

The digital inputs are used for selecting various functions in the drive. Refer to [table 7](#) to see which functions can be assigned to digital inputs.

Functions in group 1 have higher priority than the functions in group 2.

Group 1	Reset, coast stop, reset, and coast stop, quick stop, DC brake, stop, and the [Off] key.
Group 2	Start, latched start, reversing, start reversing, jog, and freeze output.

**Table 7: Digital Input Functions**

Digital input function	Select	Terminal
No operation	[0]	All, terminal 32, 33
Reset	[1]	All
Coast inverse	[2]	All, terminal 27
Coast and reset inverse	[3]	All
Quick stop inverse	[4]	All
DC brake inverse	[5]	All
Stop inverse	[6]	All
Start	[8]	All, terminal 18
Latched start	[9]	All
Reversing	[10]	All, terminal 19
Start reversing	[11]	All
Enable start forward	[12]	All
Enable start reverse	[13]	All
Jog	[14]	All, terminal 29
Preset reference on	[15]	All
Preset ref bit 0	[16]	All
Preset ref bit 1	[17]	All
Preset ref bit 2	[18]	All
Freeze reference	[19]	All
Freeze output	[20]	All

<b>Digital input function</b>	<b>Select</b>	<b>Terminal</b>
Speed up	[21]	All
Speed down	[22]	All
Set-up select bit 0	[23]	All
Set-up select bit 1	[24]	All
Precise stop inverse	[26]	18, 19
Precise start, stop	[17]	18, 19
Catch up	[28]	All
Slow down	[29]	All
Counter input	[30]	29, 33
Pulse input edge triggered	[31]	29, 33
Pulse input time based	[32]	29, 33
Ramp bit 0	[34]	All
Ramp bit 1	[35]	All
Latched precise start	[40]	18, 19
Latched precise stop inverse	[41]	18, 19
External interlock	[51]	–
DigiPot increase	[55]	All
DigiPot decrease	[56]	All
DigiPot clear	[57]	All
DigiPot hoist	[58]	All
Counter A (up)	[60]	29, 33
Counter A (down)	[61]	29, 33
Reset Counter A	[62]	All
Counter B (up)	[63]	29, 33
Counter B (down)	[64]	29, 33
Reset Counter B	[65]	All
Mech. brake feedb.	[70]	All
Mech. brake feedb. inv.	[71]	All
PID error inv.	[72]	All
PID reset I-part	[73]	All
PID enable	[74]	All
MCO specific	[75]	All
PTC card 1	[80]	All
PROFIdrive OFF2	[91]	All
PROFIdrive OFF3	[92]	All



<b>Digital input function</b>	<b>Select</b>	<b>Terminal</b>
Light-load detection	[94]	All
Evacuation	[95]	All
Mains loss	[96]	32, 33
Mains loss inverse	[97]	32, 33
Start edge triggered	[98]	All
Safety option reset	[100]	–
Enable master offset	[108]	All
Start virtual master	[109]	All
Start homing	[110]	All
Activate touch	[111]	All
Relative position	[112]	All
Enable reference	[113]	All
Sync. to Pos. mode	[114]	All
Home sensor	[115]	18, 32, 33
Home sensor inverse	[116]	18, 32, 33
Touch sensor	[117]	18, 32, 33
Touch sensor inverse	[118]	18, 32, 33
Speed mode	[119]	All
Power limit mot.	[231]	All
Power limit gen.	[232]	All
Power limit both	[233]	All
Light load + evacuation	[234]	All

The standard terminals of the drive are:

- 18
- 19
- 27
- 29
- 32
- 33

In all drive series, except for VLT® AutomationDrive FC 301, terminals 27 and 29 also function as an output.

The VLT® Extended Relay Card MCB 113 option has the following terminals:

#### **Analog outputs**

- X45/1
- X45/3

#### **Digital inputs**

- X46/1
- X46/3
- X46/5
- X46/7
- X46/9
- X46/11
- X46/13

**Relays**

- X47/3
- X47/4
- X47/5
- X47/6

Functions dedicated to only 1 digital input are stated in the associated parameter.

All digital inputs can be programmed to these functions:

**Table 8: 5-10 Digital Inputs - 1**

Option	Function
[0]	No operation No reaction to signals transmitted to the terminal.
[1]	Reset Resets the drive after a trip/alarm. Not all alarms can be reset.
[2]	Coast inverse (Default digital input 27): Coast stop, inverted input (NC). The drive leaves the motor in free mode. Logic 0⇒coast stop.
[3]	Coast and reset inverse Reset and coast stop inverted input (NC). Leaves the motor in free mode and resets the drive. Logic 0⇒coast stop and reset.
[4]	Quick stop inverse Inverted input (NC). Generates a stop in accordance with quick stop ramp time set in <i>parameter 3-81 Quick Stop Ramp Time</i> . When the motor stops, the shaft is in free mode. Logic 0⇒quick stop.
[5]	DC brake inverse Inverted input for DC brake (NC). Stops motor by energizing it with a DC current for a certain time period. See <i>parameter 2-01 DC Brake Current</i> to <i>parameter 2-03 DC Brake Cut In Speed [RPM]</i> . The function is only active when the value in <i>parameter 2-02 DC Braking Time</i> is different from 0. Logic 0⇒DC brake.
[6]	Stop inverse Stop inverted function. Generates a stop function when the selected terminal goes from logical level 1 to logical level 0.  The stop is performed according to the selected ramp time: <ul style="list-style-type: none"> <li>• <i>Parameter 3-42 Ramp 1 Ramp Down Time</i>,</li> <li>• <i>Parameter 3-52 Ramp 2 Ramp Down Time</i>,</li> <li>• <i>Parameter 3-62 Ramp 3 Ramp down Time</i>, and</li> <li>• <i>Parameter 3-72 Ramp 4 Ramp Down Time</i>.</li> </ul> <div style="border: 1px solid black; padding: 5px; margin-top: 10px;"> <p style="text-align: center; margin: 0;"><b>NOTICE</b></p> <p>When the drive is at the torque limit and has received a stop command, it may not stop by itself. To ensure that the drive stops, configure a digital output to [27] <i>Torque limit and stop</i>. Connect this digital output to a digital input that is configured as coast.</p> </div>
[8]	Start (Default digital input 18): Select start for a start/stop command. Logic 1 = start, logic 0 = stop.

Option		Function
[9]	Latched start	If a pulse is applied for minimum 2 ms, the motor starts. The motor stops when stop inverse is activated, or a reset command (via DI) is given.
[10]	Reversing	(Default digital input 19). Change the direction of motor shaft rotation. Select logic 1 to reverse. The reversing signal only changes the direction of rotation. It does not activate the start function. Select both directions in <i>parameter 4-10 Motor Speed Direction</i> . The function is not active in process closed loop.
[11]	Start reversing	Used for start/stop and for reversing on the same wire. Signals on start are not allowed at the same time.
[12]	Enable start forward	Disengages the counterclockwise movement and allows clockwise direction.
[13]	Enable start reverse	Disengages the clockwise movement and allows counterclockwise direction.
[14]	Jog	(Default digital input 29): Activate jog speed. See <i>parameter 3-11 Jog Speed [Hz]</i> .
[15]	Preset reference on	Shifts between external reference and preset reference. It is assumed that [1] <i>External/preset</i> has been selected in <i>parameter 3-04 Reference Function</i> . Logic 0 = external reference active; logic 1 = 1 of the 8 preset references is active.
[16]	Preset ref bit 0	Preset reference bit 0, 1, and 2 enable a choice between 1 of the 8 preset references according to <a href="#">table 9</a> .
[17]	Preset ref bit 1	Same as [16] <i>Preset ref bit 0</i> .
[18]	Preset ref bit 2	Same as [16] <i>Preset ref bit 0</i> .

**Table 9: Preset Reference Bit**

Preset ref. bit	2	1	0
Preset ref. 0	0	0	0
Preset ref. 1	0	0	1
Preset ref. 2	0	1	0
Preset ref. 3	0	1	1
Preset ref. 4	1	0	0
Preset ref. 5	1	0	1
Preset ref. 6	1	1	0
Preset ref. 7	1	1	1

**Table 10: 5-10 Digital Inputs - 2**

Option	Function
[19] Freeze ref	Freezes the actual reference, which is now the point of enable/condition to be used for [21] <i>Speed up</i> and [22] <i>Speed down</i> . If speed up/speed down is used, the speed change always follows ramp 2 ( <i>parameter 3-51 Ramp 2 Ramp Up Time</i> and <i>parameter 3-52 Ramp 2 Ramp Down Time</i> ) in the range 0– <i>parameter 3-03 Maximum Reference</i> .

Option		Function
[20]	Freeze output	Freezes the actual motor frequency (Hz), which is now the point of enable/condition to be used for [21] <i>Speed up</i> and [22] <i>Speed down</i> . If speed up/speed down is used, the speed change always follows ramp 2 ( <i>parameter 3-51 Ramp 2 Ramp Up Time</i> and <i>parameter 3-52 Ramp 2 Ramp Down Time</i> ) in the range 0– <i>parameter 1-23 Motor Frequency</i> .  <div style="text-align: center;"><b>NOTICE</b></div> When freeze output is active, the drive cannot be stopped via a low [8] <i>Start signal</i> . Stop the drive via a terminal programmed for [2] <i>Coasting inverse</i> or [3] <i>Coast and reset inverse</i> .
[21]	Speed up	Select [21] <i>Speed up</i> and [22] <i>Speed down</i> for digital control of the up/down speed (motor potentiometer). Activate this function by selecting either [19] <i>Freeze ref</i> or [20] <i>Freeze output</i> . When speed up/speed down is activated for less than 400 ms, the resulting reference is increased/decreased by 0.1%. If speed up/speed down is activated for more than 400 ms, the resulting reference follows the setting in ramping up/down parameters 3- x1/3-x2.

**Table 11: Shut Down/Catch Up**

	Shut down	Catch up
Unchanged speed	0	0
Reduced by %-value	1	0
Increased by %-value	0	1
Reduced by %-value	1	1

**Table 12: 5-10 Digital Inputs - 3**

Option		Function
[22]	Speed down	Same as [21] <i>Speed up</i> .
[23]	Set-up select bit 0	Select [23] <i>Set-up select bit 0</i> or select [24] <i>Set-up select bit 1</i> to select 1 of the 4 set-ups. Set <i>parameter 0-10 Active Set-up</i> to [9] <i>Multi Set-up</i> .
[24]	Set-up select bit 1	(Default digital input 32): Same as [23] <i>Set-up select bit 0</i> .
[26]	Precise stop inv.	Sends an inverted stop signal when the precise stop function is activated in <i>parameter 1-83 Precise Stop Function</i> . Precise stop inverse function is available for terminals 18 or 19.
[27]	Precise start, stop	Use when [0] <i>Precise ramp stop</i> is selected in <i>parameter 1-83 Precise Stop Function</i> . Precise start, stop is available for terminals 18 and 19. Precise start ensures that the rotor turning angle from standing still to reference is the same for each start (for same ramp time, same setpoint). This function is the equivalent to the precise stop where the rotor turning angle from reference to standstill is the same for each stop. When using <i>parameter 1-83 Precise Stop Function</i> option [1] <i>Cnt stop with reset</i> or [2] <i>Cnt stop w/o reset</i> : The drive needs a precise stop signal before reaching the value of <i>parameter 1-84 Precise Stop Counter Value</i> . If this signal is not supplied, the drive does not stop when the value in <i>parameter 1-84 Precise Stop Counter Value</i> is reached. Trigger precise start, stop by a digital input. The function is available for terminals 18 and 19.
[28]	Catch up	Increases reference value by percentage (relative) set in <i>parameter 3-12 Catch up/slow Down Value</i> .
[29]	Slow down	Reduces reference value by percentage (relative) set in <i>parameter 3-12 Catch up/slow Down Value</i> .
[30]	Counter input	Precise stop function in <i>parameter 1-83 Precise Stop Function</i> acts as counter stop or speed compensated counter stop with or without reset. Set the counter value in <i>parameter 1-84 Precise Stop Counter Value</i> .

Option	Function
[31] Pulse edge triggered	<p>Counts the number of pulse flanks per sample time. This gives a higher resolution at high frequencies, but is not as precise at lower frequencies. Use this pulse principle for encoders with low resolution (for example 30 PPR).</p> <p><b>Illustration 6: Pulse Flanks per Sample Time</b></p>
[32] Pulse time-based	<p>Measures the duration between pulse flanks. This gives a higher resolution at lower frequencies, but is not as precise at higher frequencies. This principle has a cutoff frequency, which makes it unsuited for encoders with low resolutions (for example 30 PPR) at low speeds.</p> <p><b>Illustration 8: Duration Between Pulse Flanks</b></p>
[34] Ramp bit 0	Enables a selection between 1 of the 4 ramps available, according to <a href="#">table 13</a> .
[35] Ramp bit 1	Same as [34] Ramp bit 0.

**Table 13: Preset Ramp Bit**

Preset ramp bit	1	0
Ramp 1	0	0
Ramp 2	0	1
Ramp 3	1	0
Ramp 4	1	1

**Table 14: 5-10 Digital Inputs - 4**

Option	Function
[40] Latched precise start	A latched precise start only requires a pulse of 3 ms on terminals 18 or 19. When using for <i>parameter 1-83 Precise Stop Function [1] Cnt stop with reset</i> or <i>[2] Cnt stop w/o reset</i> : When the reference is reached, the drive internally enables the precise stop signal. This means that the drive does the precise stop when the counter value of <i>parameter 1-84 Precise Stop Counter Value</i> is reached.
[41] Latched precise stop inverse	Sends a latched stop signal when the precise stop function is activated in <i>parameter 1-83 Precise Stop Function</i> . The latched precise stop inverse function is available for terminals 18 or 19.

Option		Function
[51]	External interlock	This function makes it possible to give an external fault to the drive. This fault is treated in the same way as an internally generated alarm.
[55]	DigiPot increase	Increase signal to the digital potentiometer function described in <i>parameter group 3-9* Digital Pot. Meter</i> .
[56]	DigiPot Decrease	Decrease signal to the digital potentiometer function described in <i>parameter group 3-9* Digital Pot. Meter</i> .
[57]	DigiPot Clear	Clears the digital potentiometer reference described in <i>parameter group 3-9* Digital Pot. Meter</i> .
[60]	Counter A	(Terminal 29 or 33 only). Input for increment counting in the SLC counter.
[61]	Counter A	(Terminal 29 or 33 only). Input for decrement counting in the SLC counter.
[62]	Reset Counter A	Input for reset of counter A.
[63]	Counter B	(Terminal 29 or 33 only). Input for increment counting in the SLC counter.
[64]	Counter B	(Terminal 29 or 33 only). Input for decrement counting in the SLC counter.
[65]	Reset Counter B	Input for reset of counter B.
[70]	Mech. Brake Feedback	Brake feedback for hoisting applications: Set <i>parameter 1-01 Motor Control Principle</i> to [3] Flux w/ motor feedback; set <i>parameter 1-72 Start Function</i> to [6] Hoist mech brake Ref.
[71]	Mech. Brake Feedback inv.	Inverted brake feedback for hoisting applications.
[72]	PID error inverse	When enabled, this option inverts the resulting error from the process PID controller. Available only if <i>parameter 1-00 Configuration Mode</i> is set to [6] Surface Winder, [7] Extended PID Speed OL, or [8] Extended PID Speed CL.
[73]	PID reset I-part	When enabled, this option resets the I-part of the process PID controller. Equivalent to <i>parameter 7-40 Process PID I-part Reset</i> . Available only if <i>parameter 1-00 Configuration Mode</i> is set to [6] Surface Winder, [7] Extended PID Speed OL, or [8] Extended PID Speed CL.
[74]	PID enable	Enables the extended process PID controller. Equivalent to <i>parameter 7-50 Process PID Extended PID</i> . Available only if <i>parameter 1-00 Configuration Mode</i> is set to [7] Extended PID Speed OL or [8] Extended PID Speed CL.
[80]	PTC Card 1	All digital inputs can be set to [80] PTC Card 1. However, only 1 digital input must be set to this option.
[91]	PROFIdrive OFF2	The functionality is the same as the corresponding control word bit of the PROFIBUS/PROFINET option.
[92]	PROFIdrive OFF3	The functionality is the same as the corresponding control word bit of the PROFIBUS/PROFINET option.
[94]	Light Load Detection	<p>Light-load detection is a feature for lift application to ensure that the lift runs in the evacuation direction which requires the least energy (UPS capacity), during an emergency. See <i>parameter 30-25 Light Load Delay [s]</i>, <i>parameter 30-26 Delay Before Measurements</i>, <i>parameter 30-27 Light Load Speed [%]</i>, <i>parameter 30-28 Evacuation Speed [%]</i>, and <i>parameter 30-29 Ramp Time</i> for light-load detection configurations.</p> <div style="border: 1px solid black; padding: 5px; margin-top: 10px;"> <p style="text-align: center; margin: 0;"><b>NOTICE</b></p> <p style="margin: 0;">Flying start overrules light load detection.</p> </div>

Option		Function
[95]	Evacuation	Evacuation Mode is a feature for lift application to enable drives to operate at reduced DC voltage for evacuation of the people if there is power failure. When the feature is activated, undervoltage limits and enable voltage limits is reduced so that the drive can be operated with 230 V single-phase UPS-supply.
[96]	Mains loss	Select to improve kinetic back-up. When the mains voltage goes back to a level that is close to (but still lower than) the detection level, the output speed increases and kinetic back-up remains active. To avoid this situation, send a status signal to the drive. When the signal on the digital input is low (0), the drive forcibly turns off the kinetic back-up.  <div style="text-align: center;"><b>NOTICE</b></div> <p>Only available for pulse inputs at terminals 32/33.</p>
[97]	Mains loss in-verse	When the signal on the digital input is high (1), the drive forcibly turns off the kinetic back-up. For more details, see the description of [96] <i>Mains loss</i> .  <div style="text-align: center;"><b>NOTICE</b></div> <p>Only available for pulse inputs at terminals 32/33.</p>
[98]	Start edge triggered	Edge-triggered start command. Keeps the start command alive. It can be used for a start push key.
[100]	Safe option re-set	Resets the safety option. Available only when the safety option is mounted.
[106]	Set master home	<div style="text-align: center;"><b>NOTICE</b></div> <p>This option is available only with IMC software version 48.XX.</p> Sets actual master position to the value of <i>parameter 17-88 Master Home Position</i> .
[107]	Target Inverse	<div style="text-align: center;"><b>NOTICE</b></div> <p>This option is available only with IMC software version 48.XX.</p> Changes the sign of the set target position. For example, if the set target is 1000, the activation of this option changes the value to -1000.
[108]	Enable Master Offset	<div style="text-align: center;"><b>NOTICE</b></div> <p>This option is available only with IMC software version 48.XX.</p> Activates the master offset selected in <i>parameter 3-26 Master Offset</i> when <i>parameter 17-93 Master Offset Selection</i> has a selection from [1] <i>Absolute</i> to [5] <i>Relative Touch Sensor</i> .

Option		Function
[109]	Enable Vir.Master	<p style="text-align: center;"><b>NOTICE</b></p> <p style="text-align: center;">This option is available only with IMC software version 48.XX.</p> <p>Enable signal for the virtual master function. Only applicable when option [10] <i>Synchronization</i> is selected in <i>parameter 1-00 Configuration Mode</i>.</p>
[110]	Start homing	<p style="text-align: center;"><b>NOTICE</b></p> <p style="text-align: center;">This option is available only with IMC software version 48.XX.</p> <p>Starts the homing function selected in <i>parameter 17-80 Homing Function</i>. Must remain high until homing is done, otherwise homing is aborted.</p>
[111]	Activate touch	<p style="text-align: center;"><b>NOTICE</b></p> <p style="text-align: center;">This option is available only with IMC software version 48.XX.</p> <p>Activates the monitoring of the touch sensor input.</p>
[112]	Relative position	<p style="text-align: center;"><b>NOTICE</b></p> <p style="text-align: center;">This option is available only with IMC software version 48.XX.</p> <p>This option selects between absolute and relative positioning. The option is valid for the next positioning command.</p>
[113]	Enable reference	<p style="text-align: center;"><b>NOTICE</b></p> <p style="text-align: center;">This option is available only with IMC software version 48.XX.</p> <p>Positioning mode: The drive activates the selected positioning type and target and starts the motion towards the new target. The motion starts either immediately or when active positioning is completed, depending on settings of <i>parameter 17-90 Absolute Position Mode</i> and <i>parameter 17-91 Relative Position Mode</i>. Synchronization mode: High signal locks the actual follower position to the actual master position. The follower starts and catches up with the master. Low signal stops the synchronization and the follower makes a controlled stop.</p>
[114]	Sync. to Pos. Mode	<p style="text-align: center;"><b>NOTICE</b></p> <p style="text-align: center;">This option is available only with IMC software version 48.XX.</p> <p>Select positioning in synchronization mode.</p>



Option		Function
[115]	Home sensor	<p style="text-align: center;"><b>NOTICE</b></p> <p style="text-align: center;">This option is available only with IMC software version 48.XX.</p> <p>Normally-open contact for defining the home position. The function is defined in <i>parameter 17-80 Homing Function</i>.</p>
[116]	Home sensor inv.	<p style="text-align: center;"><b>NOTICE</b></p> <p style="text-align: center;">This option is available only with IMC software version 48.XX.</p> <p>Normally-closed contact for defining the home position. The function is defined in <i>parameter 17-80 Homing Function</i>.</p>
[117]	Touch sensor	<p style="text-align: center;"><b>NOTICE</b></p> <p style="text-align: center;">This option is available only with IMC software version 48.XX.</p> <p>Normally-open contact. Serves as a reference for touch probe positioning.</p>
[118]	Touch sensor inv.	<p style="text-align: center;"><b>NOTICE</b></p> <p style="text-align: center;">This option is available only with IMC software version 48.XX.</p> <p>Normally-closed contact. Serves as a reference for touch probe positioning.</p>
[119]	Speed mode	<p style="text-align: center;"><b>NOTICE</b></p> <p style="text-align: center;">This option is available only with IMC software version 48.XX.</p> <p>Select the speed mode when [9] <i>Positioning</i> or [10] <i>Synchronization</i> is selected in <i>parameter 1-00 Configuration Mode</i>. Speed reference is set by reference resource 1 or fieldbus REF1 relative to <i>parameter 3-03 Maximum Reference</i>.</p>
[122]	Position vir. master	<p style="text-align: center;"><b>NOTICE</b></p> <p style="text-align: center;">This option is available only with IMC software version 48.XX.</p> <p>Activates position-controlled virtual master when [10] <i>Synchronization</i> is selected in <i>parameter 1-00 Configuration Mode</i>. When the option is selected, the following occurs:</p> <ul style="list-style-type: none"> <li>• Target position is set by Fieldbus Pos Ref or preset target is as defined in <i>parameter 3-20 Preset Target</i>.</li> <li>• Speed is set relative to <i>parameter 3-27 Virtual Master Max Ref</i> by the source selected in <i>parameter 3-15 Reference Resource 1</i> or fieldbus REF1.</li> <li>• Acceleration and deceleration are set as defined in <i>parameter group 3-6* Ramp 3</i>.</li> </ul>

Option		Function
[123]	Master marker	<p style="text-align: center;"><b>NOTICE</b></p> <p style="text-align: center;">This option is available only with IMC software version 48.XX.</p> <p>Normally-open contact. Serves as input for master marker signal during marker synchronization based on the option selected in <i>parameter 3-33 Sync. Mode &amp; Start Behavior</i>.</p>
[124]	Master marker inv.	<p style="text-align: center;"><b>NOTICE</b></p> <p style="text-align: center;">This option is available only with IMC software version 48.XX.</p> <p>Normally-closed contact. Activates master marker signal for marker synchronization based on the option selected in <i>parameter 3-33 Sync. Mode &amp; Start Behavior</i>.</p>
[125]	Follower marker	<p style="text-align: center;"><b>NOTICE</b></p> <p style="text-align: center;">This option is available only with IMC software version 48.XX.</p> <p>Normally-open contact. Serves as input for follower marker signal during marker synchronization based on the option selected in <i>parameter 3-33 Sync. Mode &amp; Start Behavior</i>.</p>
[126]	Follower marker inv.	<p style="text-align: center;"><b>NOTICE</b></p> <p style="text-align: center;">This option is available only with IMC software version 48.XX.</p> <p>Normally-closed contact. Serves as input for follower marker signal during marker synchronization based on the option selected in <i>parameter 3-33 Sync. Mode &amp; Start Behavior</i>.</p>
[231]	Power limit mot.	Serves as input to activate the power limit function in the motor mode. See <i>parameter group 4-8* Power Limit</i> .
[232]	Power limit gen.	Serves as input to activate the power limit function in the generating mode. See <i>parameter group 4-8* Power Limit</i> .
[233]	Power limit both	Serves as input to activate the power limit function in both the motor and the generating mode. See <i>parameter group 4-8* Power Limit</i> .
[234]	Light load + evacuation	Serves as input to activate the power limit function in both the motor and the generating mode. See <i>parameter group 4-8* Power Limit</i> .

**Table 15: 5-12 Terminal 27 Digital Input**

Option		Function
		Functions are described in <i>parameter group 5-1* Digital Inputs</i> .
[0]	No operation	
[1]	Reset	
[2]	Coast inverse	
[3]	Coast and reset inv.	
[4]	Quick stop inverse	

Option		Function
[5]	DC-brake inverse	
[6]	Stop inverse	
[8]	Start	
[9]	Latched start	
[10]	Reversing	
[11]	Start reversing	
[12]	Enable start forward	
[13]	Enable start reverse	
[14]	Jog	
[15]	Preset reference on	
[16]	Preset ref bit 0	
[17]	Preset ref bit 1	
[18]	Preset ref 2	
[19]	Freeze reference	
[20]	Freeze output	
[21]	Speed up	
[22]	Speed down	
[23]	Set-up select bit 0	
[24]	Set-up select bit 1	
[28]	Catch up	
[29]	Slow down	
[34]	Ramp bit 0	
[35]	Ramp bit 1	
[44]	Restart drive	
[51]	External interlock	
[55]	DigitPot increase	
[56]	DigiPot decrease	
[57]	DigiPot clear	
[58]	DigiPot Hoist	
[62]	Reset Counter A	
[65]	Reset Counter B	
[70]	Mech. brake feedb.	
[71]	Mech. brake feedb. inv.	
[72]	PID error inverse	
[73]	PID reset I part	

Option		Function
[74]	PID enable	
[75]	MCO specific	
[78]	Reset maint. word	
[80]	PTC card 1	
[91]	PROFIdrive OFF2	
[92]	PROFIdrive OFF3	
[94]	Light load detection	
[96]	Mains loss	
[97]	Mains loss inverse	
[98]	Start edge triggered	
[100]	Safe option reset	
[107]	Target inverse	
[108]	Enable master offset	
[109]	Start virtual master	
[110]	Start homing	
[111]	Activate touch	
[112]	Relative position	
[113]	Enable reference	
[114]	Sync. to pos. mode	
[115]	Home sensor	
[116]	Home sensor inv.	
[117]	Touch sensor	
[118]	Touch sensor inv.	
[119]	Speed mode	
[231]	Power limit mot.	
[232]	Power limit gen.	
[233]	Power limit both	

**Table 16: 5-13 Terminal 29 Digital Input**

Option		Function
		<b>NOTICE</b>
		This parameter is not available for FC 301.
		Select the function from the available digital input range and the additional options [60] Counter A, [61] Counter A, [63] Counter B, and [64] Counter B. Counters are used in smart logic control functions.
		Functions are described in <i>parameter group 5-1* Digital Inputs</i> .
[0]	No operation	
[1]	Reset	
[2]	Coast inverse	
[3]	Coast and reset inv.	
[4]	Quick stop inverse	
[5]	DC-brake inverse	
[6]	Stop inverse	
[8]	Start	
[9]	Latched start	
[10]	Reversing	
[11]	Start reversing	
[12]	Enable start forward	
[13]	Enable start reverse	
[14]	Jog	
[15]	Preset reference on	
[16]	Preset ref bit 0	
[17]	Preset ref bit 1	
[18]	Preset ref bit 2	
[19]	Freeze reference	
[20]	Freeze output	
[21]	Speed up	
[22]	Speed down	
[23]	Set-up select bit 0	
[24]	Set-up select bit 1	
[28]	Catch up	
[29]	Slow down	
[30]	Counter input	

Option		Function
[31]	Pulse edge triggered	
[32]	Pulse time based	
[34]	Ramp bit 0	
[35]	Ramp bit 1	
[44]	Restart drive	
[51]	External interlock	
[55]	DigiPot increase	
[56]	DigiPot decrease	
[57]	DigiPot clear	
[58]	DigiPot hoist	
[60]	Counter A (up)	
[61]	Counter A (down)	
[62]	Reset Counter A	
[63]	Counter B (up)	
[64]	Counter B (down)	
[65]	Reset Counter B	
[70]	Merch. brake feedb.	
[71]	Mech. brake feedb. inv.	
[72]	PID error inverse	
[73]	PID reset I-part	
[74]	PID enable	
[75]	MCO specific	
[78]	Reset maint. word	
[80]	PTC card 1	
[91]	PROFIdrive OFF2	
[92]	PROFIdrive OFF3	
[94]	Light load detection	
[96]	Mains loss	
[97]	Mains loss inverse	
[98]	Start edge triggered	
[100]	Safe option reset	
[107]	Target inverse	
[108]	Enable master offset	
[109]	Start virtual master	
[110]	Start homing	

Option		Function
[111]	Activate touch	
[112]	Relative position	
[113]	Enable reference	
[114]	Sync. to Pos. mode	
[115]	Home sensor	
[116]	Home sensor inv.	
[117]	Touch sensor	
[118]	Touch sensor inv.	
[119]	Speed mode	
[231]	Power limit mot.	
[232]	Power limit gen.	
[233]	Power limit both	

## 4.2.2 Parameter Group 5-2\* Digital Inputs

**Table 17: Parameter 5-20 Terminal X46/1 Digital Input**

Options		Function
[0]*	No operation	This parameter is active when option module VLT® Extended Relay Card MCB 113 is installed in the drive. Functions are described in <i>parameter group 5-1* Digital Inputs</i> .

**Table 18: Parameter 5-21 Terminal X46/3 Digital Input**

Option		Function
[0]*	No operation	This parameter is active when option module VLT® Extended Relay Card MCB 113 is installed in the drive. Functions are described in <i>parameter group 5-1* Digital Inputs</i> .

**Table 19: Parameter 5-22 Terminal X46/5 Digital Input**

Option		Function
[0]*	No operation	This parameter is active when option module VLT® Extended Relay Card MCB 113 is installed in the drive. Functions are described in <i>parameter group 5-1* Digital Inputs</i> .

**Table 20: Parameter 5-23 Terminal X46/7 Digital Input**

Option		Function
[0]*	No operation	This parameter is active when option module VLT® Extended Relay Card MCB 113 is installed in the drive. Functions are described in <i>parameter group 5-1* Digital Inputs</i> .

**Table 21: Parameter 5-24 Terminal X46/9 Digital Input**

Option		Function
[0]*	No operation	This parameter is active when option module VLT® Extended Relay Card MCB 113 is installed in the drive. Functions are described in <i>parameter group 5-1* Digital Inputs</i> .

**Table 22: Parameter 5-25 Terminal X46/11 Digital Input**

Option		Function
[0]*	No operation	This parameter is active when option module VLT® Extended Relay Card MCB 113 is installed in the drive. Functions are described in <i>parameter group 5-1* Digital Inputs</i> .

**Table 23: Parameter 5-26 Terminal X46/13 Digital Input**

Option		Function
[0]*	No operation	This parameter is active when option module VLT® Extended Relay Card MCB 113 is installed in the drive. Functions are described in <i>parameter group 5-1* Digital Inputs</i> .

### 4.2.3 Parameter Group 5-3\* Digital Outputs

The 2 solid-state digital outputs are common for terminals 27 and 29. Set the I/O function for terminal 27 in *parameter 5-01 Terminal 27 Mode*, and set the I/O function for terminal 29 in *parameter 5-02 Terminal 29 Mode*.

## NOTICE

These parameters cannot be adjusted while the motor is running.

**Table 24: 5-30 Digital Outputs - 1**

Option		Function
[0]	No operation	Default for all digital outputs and relay outputs.
[1]	Control ready	The control card is ready, for example: Feedback from a drive controlled by a 24 V external supply (VLT® 24 V DC Supply MCB 107) and the main power to the unit is not detected.
[2]	Drive ready	The drive is ready for operation and applies a supply signal on the control card.
[3]	Drive rdy/rem ctrl	The drive is ready for operation and is in auto-on mode.
[4]	Enable/no warning	Ready for operation. No start or stop command has been given (start/disable). No warnings are active.
[5]	Running	The motor runs, and shaft torque is present.
[6]	Running/no warning	The output speed is higher than the speed set in <i>parameter 1-81 Min Speed for Function at Stop [RPM]</i> . The motor runs and there are no warnings.
[7]	Run inrange/no warn	The motor runs within the programmed current and speed ranges set in <i>parameter 4-50 Warning Current Low to parameter 4-53 Warning Speed High</i> . There are no warnings.
[8]	Run on ref/no warn	The motor runs at reference speed. There are no warnings.
[9]	Alarm	An alarm activates the output. There are no warnings.
[10]	Alarm or warning	An alarm or warning activates the output.



Option		Function
[11]	At torque limit	The torque limit set in <i>parameter 4-16 Torque Limit Motor Mode</i> or <i>parameter 4-17 Torque Limit Generator Mode</i> has been exceeded.
[12]	Out of current range	The motor current is outside the range set in <i>parameter 4-18 Current Limit</i> .
[13]	Below current, low	The motor current is lower than set in <i>parameter 4-50 Warning Current Low</i> .
[14]	Above current, high	The motor current is higher than set in <i>parameter 4-51 Warning Current High</i> .
[15]	Out of speed range	The output frequency is outside the frequency range set in <i>parameter 4-52 Warning Speed Low</i> and <i>parameter 4-53 Warning Speed High</i> .
[16]	Below speed, low	Output speed is lower than the setting in <i>parameter 4-52 Warning Speed Low</i> .
[17]	Above speed, high	The output speed is higher than the setting in <i>parameter 4-53 Warning Speed High</i> .
[18]	Out of feedb. range	Feedback is below the limit set in <i>parameter 4-56 Warning Feedback Low</i> and <i>parameter 4-57 Warning Feedback High</i> .
19	Below feedback, low	Feedback is below the limit set in <i>parameter 4-56 Warning Feedback Low</i> .
[20]	Above feedback, high	Feedback is above the limit set in <i>parameter 4-57 Warning Feedback High</i> .
[21]	Thermal warning	The thermal warning turns on when the temperature exceeds the limit in the motor, the drive, the brake resistor, or the thermistor.
[22]	Ready, no thermal W	The drive is ready for operation, and there is no overtemperature warning.
[23]	Remote, ready, no TW	The drive is ready for operation and is in auto-on mode. There is no overtemperature warning.
[24]	Ready, voltage OK	The drive is ready for operation and the mains voltage is within the specified voltage range.
[25]	Reverse	The motor runs (or is ready to run) clockwise when logic = 0 and runs counterclockwise when logic = 1. The output changes when the reversing signal is applied.
[26]	Bus OK	Active communication (no timeout) via the serial communication port.
[27]	Torque limit & stop	Used for coast stop and in torque limit conditions. If the drive has received a stop signal and is at the torque limit, the signal is logic 0.
[28]	Brake, no brake war	Brake is active, and there are no warnings.
[29]	Brake ready, no fault	Brake is ready for operation and there are no faults.
[30]	Brake fault (IGBT)	Output is logic 1 when the brake IGBT is short-circuited. Use this function to protect the drive if there is a fault on the brake modules. To cut out the main voltage from the drive, use the output/relay.
[31]	Relay 123	Relay is activated when <i>[0] Control Word</i> is selected in <i>parameter group 8-*** Communications and Options</i> .
[32]	Mech brake ctrl	Enables control of an external mechanical brake. For more information on mechanical brake control, refer to the drive-specific design guide.
[33]	Safe stop active	Indicates that the Safe Torque Off on terminal 37 is activated.
[35]	External interlock	

Option		Function
[38]	Motor feedback error	
[40]	Out of ref range	Active when the actual speed is outside settings in <i>parameter 4-52 Warning Speed Low</i> in <i>parameter 4-55 Warning Reference High</i> .
[41]	Below reference, low	Active when the actual speed is below speed reference setting.
[42]	Above ref, high	Active when the actual speed is above speed reference setting.
[43]	Extended PID limit	
[45]	Bus ctrl.	Controls output via bus. The state of the output is set in <i>parameter 5-90 Digital &amp; Relay Bus Control</i> . If a bus timeout occurs, the output state is retained.
[46]	Bus ctrl, 1 if timeout	Controls output via bus. The state of the output is set in <i>parameter 5-90 Digital &amp; Relay Bus Control</i> . If a bus timeout occurs, the output state is set high (on).
[47]	Bus ctrl, 0 is timeout	Controls output via bus. The state of the output is set in <i>parameter 5-90 Digital &amp; Relay Bus Control</i> . If a bus timeout occurs, the output state is set low (off).
[50]	On reference	Active when a VLT® Cascade Controller MCO 102 or VLT® Motion Control MCO 305 is connected. The output is controlled from the option.
[51]	MCO controlled	Active when a VLT® Advanced Cascade Controller MCO 102 or VLT® Motion Control MCO 305 is connected. The output is controlled from the option.
[54]	24V encoder sim	Digital outputs 27 and 29 simulate a single-signal HTL encoder. Select source for the signal generation in <i>parameter 5-78 Term 27/29 Encoder Sim</i> .  <div style="border: 1px solid black; background-color: #f0f0f0; padding: 10px; text-align: center;"> <p><b>NOTICE</b></p> <p>Option [54] 24V encoder sim must be selected in both <i>parameter 5-30 Terminal 27 Digital Output</i> and <i>parameter 5-31 Terminal 29 Digital Output</i>. This option is only available for software version 48.xx for VLT® AutomationDrive FC 302.</p> </div>
[55]	Pulse output	
[58]	Actual position	
[59]	Actual position 4–20 mA	
[60]	Comparator 0	See <i>parameter group 13-1* Comparators</i> . If comparator 0 is evaluated as true, the output goes high. Otherwise, it is low.
[61]	Comparator 1	See <i>parameter group 13-1* Comparators</i> . If comparator 1 is evaluated as true, the output goes high. Otherwise, it is low.
[62]	Comparator 2	See <i>parameter group 13-1* Comparators</i> . If comparator 2 is evaluated as true, the output goes high. Otherwise, it is low.
[63]	Comparator 3	See <i>parameter group 13-1* Comparators</i> . If comparator 3 is evaluated as true, the output goes high. Otherwise, it is low.
[64]	Comparator 4	See <i>parameter group 13-1* Comparators</i> . If comparator 4 is evaluated as true, the output goes high. Otherwise, it is low.
[65]	Comparator 5	See <i>parameter group 13-1* Comparators</i> . If comparator 5 is evaluated as true, the output goes high. Otherwise, it is low.

Option		Function
[70]	Logic rule 0	See <i>parameter group 13-4* Logic Rules</i> . If logic rule 0 is evaluated as true, the output goes high. Otherwise, it is low.
[71]	Logic Rule 1	See <i>parameter group 13-4* Logic Rules</i> . If logic rule 1 is evaluated as true, the output goes high. Otherwise, it is low.
[72]	Logic Rule 2	See <i>parameter group 13-4* Logic Rules</i> . If logic rule 2 is evaluated as true, the output goes high. Otherwise, it is low.
[73]	Logic rule 3	See <i>parameter group 13-4* Logic Rules</i> . If logic rule 3 is evaluated as true, the output goes high. Otherwise, it is low.
[74]	Logic rule 4	See <i>parameter group 13-4* Logic Rules</i> . If logic rule 4 is evaluated as true, the output goes high. Otherwise, it is low.
[75]	Logic rule 5	See <i>parameter group 13-4* Logic Rules</i> . If logic rule 5 is evaluated as true, the output goes high. Otherwise, it is low.
[80]	SL digital output A	See <i>parameter 13-52 SL Controller Action</i> . The output goes high whenever the smart logic action [38] <i>Set dig. out. A high</i> is executed. The output goes low whenever the smart logic action [32] <i>Set dig. out. A low</i> is executed.
[81]	SL digital output B	See <i>parameter 13-52 SL Controller Action</i> . The output goes high whenever the smart logic action [39] <i>Set dig. out. B high</i> is executed. The output goes low whenever the smart logic action [33] <i>Set dig. out. B low</i> is executed.
[82]	SL digital output C	See <i>parameter 13-52 SL Controller Action</i> . The output goes high whenever the smart logic action [40] <i>Set dig. out. C high</i> is executed. The output goes low whenever the smart logic action [34] <i>Set dig. out. C low</i> is executed.
[83]	SL digital output D	See <i>parameter 13-52 SL Controller Action</i> . The output goes high whenever the smart logic action [41] <i>Set dig. out. D high</i> is executed. The output goes low whenever the smart logic action [35] <i>Set dig. out. D low</i> is executed.
[84]	SL digital output E	See <i>parameter 13-52 SL Controller Action</i> . The output goes high whenever the smart logic action [42] <i>Set dig. out. E high</i> is executed. The output goes low whenever the smart logic action [36] <i>Set dig. out. E low</i> is executed.
[85]	SL digital output F	See <i>parameter 13-52 SL Controller Action</i> . The output goes high whenever the smart logic action [43] <i>Set dig. out. F high</i> is executed. The output goes low whenever the smart logic action [37] <i>Set dig. out. F low</i> is executed.
[90]	kWh counter pulse	Sends a pulse (200 ms pulse width) to output terminal whenever kWh counter changes ( <i>parameter 15-02 kWh Counter</i> ).
[98]	Virtual master dir.	<div style="text-align: center; background-color: #cccccc; padding: 5px;"><b>NOTICE</b></div> <div style="border: 1px solid black; padding: 5px; margin: 5px auto; width: fit-content;">                     This option is available only with software version 48.xx of the VLT® AutomationDrive FC 302.                 </div> <p>A virtual master signal that controls the rotation direction of slaves.</p>
[120]	Local ref active	Output is high when <i>parameter 313 Reference Site = [2] Local</i> .

**Table 25: Local Reference Active**

Reference site set in <i>parameter 3-13 Reference Site</i>	Local reference active [120]	Remote reference active [121]
Reference site: Local <i>parameter 3-13 Reference Site [2] Local</i>	1	0
Reference site: Remote <i>parameter 3-13 Reference Site [1] Remote</i>	0	1

Reference site set in <i>parameter 3-13 Reference Site</i>	Local reference active [120]	Remote reference active [121]
Reference site: Linked to Hand/ Auto	–	–
Hand	1	0
Hand⇒off	1	0
Auto⇒off	0	0
Auto	0	1

**Table 26: 5-30 Digital Outputs - 2**

Option	Function
[121] Remote ref active	Output is high when <i>parameter 3-13 Reference Site</i> = [1] Remote or [0] Linked to hand/auto while the LCP is in auto-on mode. See <a href="#">table 25</a> .
[122] No alarm	Output is high when no alarm is present.
[123] Start command active	Output is high when there is an active start command (that is via digital input bus connection, hand-on, or auto-on), and no stop or start command is active.
[124] Running reverse	Output is high when the drive runs counterclockwise (the logical product of the status bits running AND reverse).
[125] Drive in hand mode	Output is high when the drive is in hand-on mode (as indicated by the LED light above [Hand On]).
[126] Drive in auto mode	Output is high when the drive is in auto-on mode (as indicated by the LED light above [Auto On]).
[151] ATEX ETR cur. alarm	Selectable if <i>parameter 1-90 Motor Thermal Protection</i> is set to [20] ATEX ETR or [21] Advanced ETR. If Alarm 164 ATEX ETR cur.lim.alarm is active, the output is 1.
[152] ATEX ETR freq. alarm	Selectable if <i>parameter 1-90 Motor Thermal Protection</i> is set to [20] ATEX ETR or [21] Advanced ETR. If Alarm 166 ATEX ETR freq.lim.alarm is active, the output is 1.
[153] ATEX ETR cur. warning	
[154] ATEX ETR freq. warning	Selectable if <i>parameter 1-90 Motor Thermal Protection</i> is set to [20] ATEX ETR or [21] Advanced ETR. If Warning 165, ATEX ETR freq.lim.warning is active, the output is 1.
[180] Clock fault	
[181] Prev. maintenance	
[188] AHF capacitor connect	The capacitors are turned on at 20% (hysteresis of 50% gives an interval of 10– 30%). The capacitors are disconnected below 10%. The off delay is 10 s and restarts if the nominal power goes above 10% during the delay. <i>Parameter 5-80 AHF Cap Reconnect Delay</i> is used to guarantee a minimum off time for the capacitors.
[189] External fan control	The internal logics for the internal fan control is transferred to this output to make it possible to control an external fan (relevant for hp duct cooling).
[190] Safe function active	
[191] Safe opt. reset req.	
[192] RS Flipflop 0	See <i>parameter group 13-1* Comparators</i> .
[193] RS Flipflop 1	See <i>parameter group 13-1* Comparators</i> .
[194] RS Flipflop 2	See <i>parameter group 13-1* Comparators</i> .

Option		Function
[195]	RS Flipflop 3	See parameter group 13-1* Comparators.
[196]	RS Flipflop 4	See parameter group 13-1* Comparators.
[197]	RS Flipflop 5	See parameter group 13-1* Comparators.
[198]	RS Flipflop 6	See parameter group 13-1* Comparators.
[199]	RS Flipflop 7	See parameter group 13-1* Comparators.
[221]	IGBT cooling	Use this option for handling the overcurrent trips. When the drive detects an overcurrent condition, it shows <i>alarm 13, Overcurrent</i> and triggers a reset. If the overcurrent condition occurs for the 3 <sup>rd</sup> time in a row, the drive shows <i>alarm 13, Overcurrent</i> and initiates a 3-minute delay before the next reset.
[222]	Homing OK	<p style="text-align: center;"><b>NOTICE</b></p> <p style="text-align: center;">This option is available only with software version 48.xx for VLT® AutomationDrive FC 302.</p> <p>Homing is completed with the homing function selected in <i>parameter 17-80 Homing Function</i>.</p>
[223]	On target	<p style="text-align: center;"><b>NOTICE</b></p> <p style="text-align: center;">This option is available only with software version 48.xx for VLT® AutomationDrive FC 302.</p> <p>Positioning is completed and the on-target signal is sent when the actual position is within <i>parameter 3-05 On Reference Window</i> for the duration of <i>parameter 3-09 On Target Time</i> and the actual speed does not exceed <i>parameter 3-05 On Reference Window</i>.</p>
[224]	Position limit	<p style="text-align: center;"><b>NOTICE</b></p> <p style="text-align: center;">This option is available only with software version 48.xx for VLT® AutomationDrive FC 302.</p> <p>The position error exceeds the value in <i>parameter 4-71 Maximum Position Error</i> for the time set in <i>parameter 4-72 Position Error Timeout</i>.</p>
[225]	Position error	<p style="text-align: center;"><b>NOTICE</b></p> <p style="text-align: center;">This option is available only with software version 48.xx for VLT® AutomationDrive FC 302.</p> <p>The position is outside the limits set in <i>parameter 3-06 Minimum Position</i> and <i>parameter 3-07 Maximum Position</i>.</p>
[226]	Touch on target	<p style="text-align: center;"><b>NOTICE</b></p> <p style="text-align: center;">This option is available only with software version 48.xx for VLT® AutomationDrive FC 302.</p> <p>Touch probe positioning active. The drive monitors the touch probe sensor input.</p>
[231]	In power lim. mot.	
[232]	In power lim. gen.	
[233]	In power limit	

## 4.2.4 Parameter Group 5-4\* Relays

**Table 27: Parameter 5-40 Function Relay - 1**

Option		Function
		Relay 1 [0], relay 2 [1] <sup>(1)</sup> .  VLT® Extended Relay MCB 113: X47/Relay 3 [2], X47/Relay 4 [3], X47/Relay 5 [4], X47/Relay 6 [5].  VLT® Relay Card MCB 105: Relay 7 [6], relay 8 [7], relay 9 [8].
[0]	No operation	Default setting for all digital and relay outputs.
[1]	Control ready	The control card is ready, for example: Feedback from a drive where the control is supplied by an 24 V external supply (VLT® 24 V DC Supply MCB 107) and the main power to drive is not detected.
[2]	Drive ready	The drive is ready to operate. Mains and control supplies are OK.
[3]	Drive rdy/rem ctrl	The drive is ready for operation and is in auto-on mode.
[4]	Enable/no warning	Ready for operation. No start or stop commands have been applied (start/disable). No warnings are active.
[5]	Running	The motor is running, and shaft torque is present.
[6]	Running/no warning	Output speed is higher than the speed set in <i>parameter 1-81 Min Speed for Function at Stop [RPM]</i> . The motor runs and there are no warnings.
[7]	Run in range/no warn	The motor runs at reference speed. No warnings.
[8]	Run on ref/no warn	The motor runs at reference speed. No warnings.
[9]	Alarm	An alarm activates the output. No warnings.
[10]	Alarm or warning	An alarm or a warning activates the output.
[11]	At torque limit	The torque limit set in <i>parameter 4-16 Torque Limit Motor Mode</i> or <i>parameter 4-17 Torque Limit Generator Mode</i> has been exceeded.
[12]	Out of current range	The motor current is outside the range set in <i>parameter 4-18 Current Limit</i> .
[13]	Below current, low	The motor current is lower than set in <i>parameter 4-50 Warning Current Low</i> .
[14]	Above current, high	The motor current is higher than set in <i>parameter 4-51 Warning Current High</i> .
[15]	Out of speed range	Output speed/frequency is outside the frequency range set in <i>parameter 4-52 Warning Speed Low</i> and <i>parameter 4-53 Warning Speed High</i> .
[16]	Below speed, low	Output speed is lower than the setting in <i>parameter 4-52 Warning Speed Low</i> .
[17]	Above speed, high	Output speed is higher than the setting in <i>parameter 4-53 Warning Speed High</i> .
[18]	Out of feedb. range	Feedback is outside the range set in <i>parameter 4-56 Warning Feedback Low</i> and <i>parameter 4-57 Warning Feedback High</i> .
[19]	Below feedback, low	Feedback is below the limit set in <i>parameter 4-56 Warning Feedback Low</i> .
[20]	Above feedback, high	Feedback is above the limit set in <i>parameter 4-57 Warning Feedback High</i> .

Option		Function
[21]	Thermal warning	Thermal warning turns on when the temperature exceeds the limit either in motor, drive, brake resistor, or connected thermistor.
[22]	Ready, no thermal W	The drive is ready for operation and there is no overtemperature warning.
[23]	Remote, ready, no TW	The drive is ready for operation and is in auto-on mode. There is no overtemperature warning.
[24]	Ready, voltage OK	The drive is ready for operation and the mains voltage is within the specified voltage range.
[25]	Reverse	The motor runs (or is ready to run) clockwise when logic=0 and counterclockwise when logic=1. The output changes when the reversing signal is applied.
[26]	Bus OK	Active communication (no timeout) via the serial communication port.
[27]	Torque limit & stop	Used for coast stop and in torque limit conditions. If the drive has received a stop signal and is in torque limit, the signal is logic 0.
[28]	Brake, no brake war	The brake is active, and there are no warnings.
[29]	Brake ready, no fault	Brake is ready for operation, and there are no faults.
[30]	Brake faults (IGBT)	Output is logic 1 when the brake IGBT is short-circuited. Use this function to protect the drive if there is a fault on the brake module. Use the digital output/relay to cut out the main voltage from the drive.
[31]	Relay 123	Digital output/relay is activated when [0] <i>Control Word</i> is selected in <i>parameter group 8-** Comm. and Options</i> .
[32]	Mech brake ctrl	Selection of mechanical brake control. When selected parameters in <i>parameter group 2-2* Mechanical Brake</i> are active, the output must be reinforced to carry the current for the coil in the brake. Usually, solved by connecting an external relay to the selected digital output.
[33]	Safe stop active	Indicated that the Safe Torque Off on terminal 37 has been activated.
[36]	Control word bit 11	Activate relay 1 by control word from fieldbus. No other functional impact in the drive. Typical application: Controlling auxiliary device from fieldbus. The function is valid when [0] <i>FC profile</i> in <i>parameter 8-10 Control Word Profile</i> is selected.
[37]	Control word bit 12	Activate relay 2 by control word from fieldbus. No other functional impact in the drive. Typical application: Controlling auxiliary device from fieldbus. The function is valid when [0] <i>FC profile</i> in <i>parameter 8-10 Control Word Profile</i> is selected.
[38]	Motor feedback error	Failure in the speed feedback loop from motor running in closed loop. The output can eventually be used to prepare switching the drive in open loop in an emergency case.
[39]	Tracking error	When the difference between the calculated speed and the actual speed in <i>parameter 4-35 Tracking Error</i> is larger than selected, the output/relay is active.
[40]	Out of ref range	Active when the actual speed is outside the settings in <i>parameter 4-52 Warning Speed Low</i> to <i>parameter 4-55 Warning Reference High</i> .
[41]	Below reference, low	Active when the actual speed is below the speed reference setting.
[42]	Above ref, high	Active when the actual speed is above the speed reference setting.
[43]	Extended PID Limit	
[45]	Bus ctrl.	Controls digital output/relay via bus. The state of the output is set in <i>parameter 5-90 Digital &amp; Relay Bus Control</i> . The output state is retained if a bus timeout occurs.

Option		Function
[46]	Bus ctrl, 1 if time-out	Controls the output via bus. The state of the output is set in <i>parameter 5-90 Digital &amp; Relay Bus Control</i> . If a bus timeout occurs, the output state is set high (on).
[47]	Bus ctrl, 0 if time-out	Controls the output via bus. The state of the output is set in <i>parameter 5-90 Digital &amp; Relay Bus Control</i> . If a bus timeout occurs, the output state is set low (off).
[51]	MCO controlled	Active when an VLT® Advanced Cascade Controller MCO 102 or VLT® Motion Control MCO 305 is connected. The output is controlled from the option.
[60]	Comparator 0	See <i>parameter group 13-1* Comparators</i> . If comparator 0 in SLC is true, the output goes high. Otherwise, it is low.
[61]	Comparator 1	See <i>parameter group 13-1* Comparators</i> . If comparator 1 in SLC is true, the output goes high. Otherwise, it is low.
[62]	Comparator 2	See <i>parameter group 13-1* Comparators</i> . If comparator 2 in SLC is true, the output goes high. Otherwise, it is low.
[63]	Comparator 3	See <i>parameter group 13-1* Comparators</i> . If comparator 3 in SLC is true, the output goes high. Otherwise, it is low.
[64]	Comparator 4	See <i>parameter group 13-1* Comparators</i> . If comparator 4 in SLC is true, the output goes high. Otherwise, it is low.
[65]	Comparator 5	See <i>parameter group 13-1* Comparators</i> . If comparator 5 in SLC is true, the output goes high. Otherwise, it is low.
[70]	Logic rule 0	See <i>parameter group 13-4* Smart Logic Control</i> . If logic rule 0 in SLC is true, the output goes high. Otherwise, it is low.
[71]	Logic rule 1	See <i>parameter group 13-4* Smart Logic Control</i> . If logic rule 1 in SLC is true, the output goes high. Otherwise, it is low.
[72]	Logic rule 2	See <i>parameter group 13-4* Smart Logic Control</i> . If logic rule 2 in SLC is true, the output goes high. Otherwise, it is low.
[73]	Logic rule 3	See <i>parameter group 13-4* Smart Logic Control</i> . If logic rule 3 in SLC is true, the output goes high. Otherwise, it is low.
[74]	Logic rule 4	See <i>parameter group 13-4* Smart Logic Control</i> . If logic rule 4 in SLC is true, the output goes high. Otherwise, it is low.
[75]	Logic rule 5	See <i>parameter group 13-4* Smart Logic Control</i> . If logic rule 5 in SLC is true, the output goes high. Otherwise, it is low.
[80]	SL digital output A	See <i>parameter 13-52 SL Controller Action</i> . The output goes high whenever the smart logic action [38] <i>Set dig. out. A high</i> is executed. The output goes low whenever the smart logic action [32] <i>Set dig. out. A low</i> is executed.
[81]	SL digital output B	See <i>parameter 13-52 SL Controller Action</i> . The output goes high whenever the smart logic action [39] <i>Set dig. out. A high</i> is executed. The output goes low whenever the smart logic action [33] <i>Set dig. out. A low</i> is executed.
[82]	SL digital output C	See <i>parameter 13-52 SL Controller Action</i> . The output goes high whenever the smart logic action [40] <i>Set dig. out. A high</i> is executed. The output goes low whenever the smart logic action [34] <i>Set dig. out. A low</i> is executed.
[83]	SL digital output D	See <i>parameter 13-52 SL Controller Action</i> . The output goes high whenever the smart logic action [41] <i>Set dig. out. A high</i> is executed. The output goes low whenever the smart logic action [35] <i>Set dig. out. A low</i> is executed.



Option		Function
[84]	SL digital output E	See <i>parameter 13-52 SL Controller Action</i> . The output goes high whenever the smart logic action [42] <i>Set dig. out. A high</i> is executed. The output goes low whenever the smart logic action [36] <i>Set dig. out. A low</i> is executed.
[85]	SL digital output F	See <i>parameter 13-52 SL Controller Action</i> . The output goes high whenever the smart logic action [43] <i>Set dig. out. A high</i> is executed. The output goes low whenever the smart logic action [37] <i>Set dig. out. A low</i> is executed.
[120]	Local ref active	The output is high when <i>parameter 3-13 Reference Site = [2] Local</i> or when <i>parameter 3-13 Reference Site 0 [0] Linked to hand auto</i> at the time as the LCP is in hand-on mode.

<sup>1</sup> The numbers in the [ ] positioned after the relay numbers are the index values in the parameter.

**Table 28: Local Reference Active**

Reference site in <i>parameter 3-13 Reference Site</i>	Local reference active [120]	Remote reference active [121]
Reference site: Local <i>parameter 3-13 Reference Site, [2] Local</i>	1	0
Reference site: Remote <i>Parameter 3-13 Reference Site, [1] Remote</i>	0	1
Reference site: Linked to hand/auto		
Hand	1	0
Hand⇒off	1	0
Auto⇒off	0	0
Auto	0	1

**Table 29: Parameter 5-40 Relays - 2**

Option		Function
[121]	Remote ref active	Output is high when <i>parameter 3-13 Reference Site = [1] Remote</i> or [0] <i>Linked to hand/auto</i> while the LCP is in auto-on mode. See <a href="#">table 28</a> .
[122]	No alarm	The output is high when no alarm is present.
[123]	Start command active	Output is high when the start command is high (that is via digital input, bus connection, [Hand On], or [Auto On]), and a stop has been last command.
[124]	Running reverse	Output is high when the drive is running counterclockwise (the logical product of the status bits <i>running AND reverse</i> ).
[125]	Drive in hand mode	Output is high when the drive is in hand-on mode (the LED above [Hand On] is lit).
[126]	Drive in auto mod	Output is high when the drive is in auto-on mode (the LED above [Auto On] is lit).
[151]	ATEX ETR cur. alarm	Selectable if <i>parameter 1-90 Motor Thermal Protection</i> is set to [20] <i>ATEX ETR</i> or [21] <i>Advanced ETR</i> . If <i>alarm 164, ATEX ETR cur.lim.alarm</i> is active, the output is 1.
[152]	ATEX ETR freq. alarm	Selectable if <i>parameter 1-90 Motor Thermal Protection</i> is set to [20] <i>ATEX ETR</i> or [21] <i>Advanced ETR</i> . If <i>alarm 166, ATEX ETR freq.lim.alarm</i> is active, the output is 1.

Option	Function
[153] ATEX ETR cur. warning	Selectable if <i>parameter 1-90 Motor Thermal Protection</i> is set to [20] ATEX ETR or [21] Advanced ETR. If <i>alarm 163, ATEX ETR cur.lim.warning</i> is active, the output is 1.
[154] ATEX ETR freq. warning	Selectable if <i>parameter 1-90 Motor Thermal Protection</i> is set to [20] ATEX ETR or [21] Advanced ETR. If <i>alarm 165, ATEX ETR freq.lim.warning</i> is active, the output is 1.
[188] AHF capacitor connect	
[189] External fan control	The internal logics for the internal fan control are transferred to this output to make it possible to control an external fan (relevant for high-power duct cooling).
[190] Safe function active	
[191] Safe opt. reset req.	
[192] RS Flipflop 0	See <i>parameter group 13-1* Comparators</i> .
[193] RS Flipflop 1	See <i>parameter group 13-1* Comparators</i> .
[194] RS Flipflop 2	See <i>parameter group 13-1* Comparators</i> .
[195] RS Flipflop 3	See <i>parameter group 13-1* Comparators</i> .
[196] RS Flipflop 4	See <i>parameter group 13-1* Comparators</i> .
[197] RS Flipflop 5	See <i>parameter group 13-1* Comparators</i> .
[198] RS Flipflop 6	See <i>parameter group 13-1* Comparators</i> .
[199] RS Flipflop 7	See <i>parameter group 13-1* Comparators</i> .

Table 30: Parameter 5-41 On Delay, Relay

Range	Function
	Array [9]
0.01 s* [0.01 600.00 s]	<p>Enter the delay of the relay cut-in time. See <a href="#">table 27</a>.</p> <p style="text-align: right;">e30ba171.11</p>

Table 31: Parameter 5-42 Off Delay, Relay

Range	Function
	Array [9]

Range	Function
0.01 s* [0.01–600.00 s]	<p>Enter the delay of the relay cutout time. See <a href="#">table 27</a></p> <p>If the selected event condition changes before the on- or off delay timer expires, the relay output is unaffected.</p>

### 4.3 6-\*\* Analog Outputs

#### 4.3.1 6-7\* Analog Output 3 MCB 113

Parameters for configuring the scaling and limits for analog output, terminals X45/1, and X45/2. Analog outputs are current outputs: 0/4–20 mA. Resolution of analog output is 11 bit.

**Table 32: Parameter 6-70 Terminal X45/1 Output**

Option	Function
	Select the function of terminal X45/1 as an analog current output.
[0]	No operation When no signal on the analog output is present.
[52]	MCO 305 0–20 mA
[53]	MCO 305 4–20 mA
[100]	Output frequency 0–20 mA 0 Hz = 0 mA; 100 Hz = 20 mA
[101]	Reference 0–20 mA <i>Parameter 3-00 Reference Range [0] Min.–Max. 0% = 0 mA; 100% = 20 mA. Parameter 3-00 Reference Range [1] -Max.–+Max. -100% = 0 mA; 0% = 10 mA; +100% = 20 mA.</i>
[102]	Feedback
[103]	Motor current 0–20 mA The value is taken from <i>parameter 16-37 Inv. Max. Current</i> . The inverter maximum current (160% current) is equal to 20 mA. Example: Inverter normal current (11 kW) = 24 A. 160% = 38.4 A. Motor normal current = 22 A, readout 11.46 mA. $\frac{20 \text{ mA} \times 22 \text{ A}}{38.4 \text{ A}} = 11.46 \text{ mA}$ If the normal motor current is equal to 20 mA, the output setting of <i>parameter 6-52 Terminal 42 Output Max Scale</i> is: $\frac{I_{VLT, \text{Max}} \times 100}{I_{\text{Motor, Norm}}} = \frac{38.4 \times 100}{22} = 175 \%$
[104]	Torque rel to lim 0–20 mA The torque setting is related to the setting in <i>parameter 4-16 Torque Limit Motor Mode</i> .

Option		Function
[105]	Torque rel to rated motor torque 0–20 mA	The torque is related to the motor torque setting.
[106]	Power 0–20 mA	Taken from <i>parameter 1-20 Motor Power [kW]</i> .
[107]	Speed 0–20 mA	Taken from <i>parameter 3-03 Maximum Reference</i> . 20 mA = value in <i>parameter 3-03 Maximum Reference</i> .
[108]	Torque ref. 0–20 mA	Torque reference related to 160% torque.
[109]	Max. out freq 0–20 mA	In relation to <i>parameter 4-19 Max Output Frequency</i> .
[130]	Output freq. 4–20 mA	0 Hz = 4 mA, 100 Hz = 20 mA.
[131]	Reference 4–20 mA	<i>Parameter 3-00 Reference Range [0] Min.–Max.</i> 0% = 4 mA; 100% = 20 mA. <i>Parameter 3-00 Reference Range [1] -Max.–+Max.</i> -100% = 4 mA; 0% = 12 mA; +100% = 20 mA.
[132]	Feedback 4–20 mA	
[133]	Motor cur. 4–20 mA	<p>The value is taken from <i>parameter 16-37 Inv. Max. Current</i>. The inverter maximum current (160% current) is equal to 20 mA. Example: Inverter normal current (11 kW) = 24 A. 160% = 38.4 A. Motor normal current = 22 A, readout 11.46 mA.</p> $\frac{16 \text{ mA} \times 22 \text{ A}}{38.4 \text{ A}} = 9.17 \text{ mA}$ <p>If the normal motor current is equal to 20 mA, the output setting of <i>parameter 6-52 Terminal 42 Output Max Scale</i> is:</p> $\frac{I_{VLT, \text{Max}} \times 100}{I_{\text{Motor, Norm}}} = \frac{38.4 \times 100}{22} = 175 \%$
[134]	Torque % lim. 4–20 mA	The torque setting is related to the setting in <i>parameter 4-16 Torque Limit Motor Mode</i> .
[135]	Torque % nom 4–20 mA	The torque setting is related to the motor torque setting.
[136]	Power 4–20 mA	Taken from <i>parameter 1-20 Motor Power [kW]</i> .
[137]	Speed 4–20 mA	Taken from <i>parameter 3-03 Maximum Reference</i> . 20 mA = value in <i>parameter 3-03 Maximum Reference</i> .
[138]	Torque 4–20 mA	Torque reference related to 160% torque.
[139]	Bus ctrl. 0–20 mA	An output value set from fieldbus process data. The output works independently of internal functions in the drive.
[140]	Bus ctrl. 4–20 mA	An output value set from fieldbus process data. The output works independently of internal functions in the drive.
[141]	Bus ctrl. 0–20 mA, timeout	<i>Parameter 4-54 Warning Reference Low</i> defines the behavior of the analog output if a fieldbus timeout occurs.
[142]	Bus ctrl. 4–20 mA, timeout	<i>Parameter 4-54 Warning Reference Low</i> defined the behavior of the analog output if a fieldbus timeout occurs.
[150]	Max. out freq 4–20 mA	In relation to <i>parameter 4-19 Max Output Frequency</i> .

**Table 33: Parameter 6-71 Terminal X45/1 Output Min. Scale**

Range	Function
0.00%* [0.00–2000%]	Scale the minimum output of the selected analog signal at terminal X45/1 as a percentage of the maximum signal value. For example, if 0 mA (or 0 Hz) is required at 25% of the maximum output value, then program 25%. Scaling values up to 100% can never exceed the corresponding setting in <i>parameter 6-72 Terminal X45/1 Max. Scale</i> .

**Table 34: Parameter 6-72 Terminal X45/1 Output Max. Scale**

Range	Function
100%* [0.00–200.00%]	<p>Scale the maximum output of the selected analog signal at terminal X45/1. Set the value to the maximum value of the current signal output. Scale the output to give a current lower than 20 mA at full scale, or 20 mA at an output below 100% of the maximum signal value. If 20 mA is the required output current at a value between 0–100% of the full-scale output, program the percentage value in the parameter, for example 50% = 20 mA. If a current 4–20 mA is required at maximum output (100%), calculate the percentage value as follows (example where required maximum output is 10 mA):</p> $\frac{I_{\text{RANGE}} [\text{mA}]}{I_{\text{DESIRED MAX}} [\text{mA}]} \times 100 \% = \frac{20 - 4 \text{ mA}}{10 \text{ mA}} \times 100 \% = 160 \%$

**Illustration 9: Output Maximum Scale**

**Table 35: Parameter 6-73 Terminal X45/1 Output Bus Control**

Range	Function
0.00%* [0.00–100.00%]	Holds the level of analog output 3 (terminal X45/1) if controlled by bus.

**Table 36: Parameter 6-74 Terminal X45/1 Output Timeout Preset**

Range	Function
0.00%* [0.00–100.00%]	Holds the preset level of analog output 3 (terminal X45/1). If there is a fieldbus timeout and a timeout function is selected in <i>parameter 6-70 Terminal X45/1 Output</i> , the output is preset to this level.

### 4.3.2 6-8\* Analog Output 4 MCB 113

Parameters for configuring the scaling and limits for analog output 4, terminals X45/3 and X45/4. Analog outputs are current outputs: 0/4 to 20 mA. Resolution on analog output is 11 bit.

**Table 37: Parameter 6-80 Terminal X45/3 Output**

Option	Function
	Select the function of terminal X45/3 as an analog current output.
[0]*	No operation Same selections available as for <i>parameter 6-70 Terminal X45/1 Output</i> .

**Table 38: Parameter 6-81 Terminal X45/3 Output Min. Scale**

Range	Function
[0.00%]* 0.00–200.00%	Scales the minimum output of the selected analog signal on terminal X45/3. Scale the minimum value as a percentage of the maximum signal value, for example, 0 mA (or 0 Hz) is required at 25% of the maximum output value and 25% is programmed. The value can never exceed the corresponding setting in <i>parameter 6-82 Terminal X45/3 Max. Scale</i> if the value is below 100%. This parameter is active when VLT® Extended Relay Card MCB 113 is mounted in the drive.

**Table 39: Parameter 6-82 Terminal X45/3 Output Max. Scale**

Range	Function
[0.00%]* 0.00–200.00%	Scales the maximum output of the selected analog signal on terminal X45/3. Scale the value to the required maximum value of the current signal output. Scale the output to give a lower current than 20 mA at full scale or 20 mA at an output below 100% of the maximum signal value. If 20 mA is the required output current at a value between 0–100% of the full-scale output, program the percentage value in the parameter, for example, 50% = 20 mA. If a current of 4–20 mA is required at maximum output (100%), calculate the percentage value as follows (example where required maximum output is 10 mA): $\frac{I_{\text{RANGE}} [\text{mA}]}{I_{\text{DESIRED MAX}} [\text{mA}]} \times 100 \% = \frac{20 - 4 \text{ mA}}{10 \text{ mA}} \times 100 \% = 160 \%$

**Table 40: Parameter 6-83 Terminal X45/3 Output Bus Scale**

Range	Function
[0.00%]* 0.00–100.00%	Holds the level of output 4 (X45/3) if controlled by bus.

**Table 41: Parameter 6-84 Terminal X45/3 Output Timeout Preset**

Range	Function
[0.00%]* 0.00–100.00%	Holds the preset level of output 4 (X45/3). If there is a fieldbus timeout and a timeout function is selected in <i>parameter 6-80 Terminal X45/3 Output</i> , the output is preset to this level.

## 4.4 14-\*\* 24 V DC External Supply

### 4.4.1 14-8\* Options

**Table 42: Parameter 14-80 Option Supplied by External 24VDC**

Option	Function
	<p><b>NOTICE</b></p> <p>This parameter is only changing function by performing a power cycle.</p>

Option		Function
[0]	No	Select [0] No to use the 24 V DC supply of the drive.
[1]*	Yes	Select [1] Yes if a 24 V DC external supply is used to power the option. Inputs/outputs are galvanically isolated from the drive when operated from an external supply.

## 4.5 16-\*\* Data Readouts

### 4.5.1 16-6\* Inputs and Outputs

**Table 43: Parameter 16-60 Digital Input**

Range		Function
0*	[0–63]	View the signal states from the active digital inputs. Example: Input 18 corresponds to bit number 5; 0 = no signal; 1 = connected signal. Bit 6 works in the opposite way; 0 = on; 1 = off (safe stop input).

Bit 0	Digital input term. 33
Bit 1	Digital input term. 32
Bit 2	Digital input term. 29
Bit 3	Digital input term. 27
Bit 4	Digital input term. 19
Bit 5	Digital input term. 18
Bit 6	Digital input term. 37
Bit 7	Digital input GP I/O term. X30/4
Bit 8	Digital input GP I/O term. X30/3
Bit 9	Digital input GP I/O term. C30/2
Bits 10–63	Reserved for future terminals.

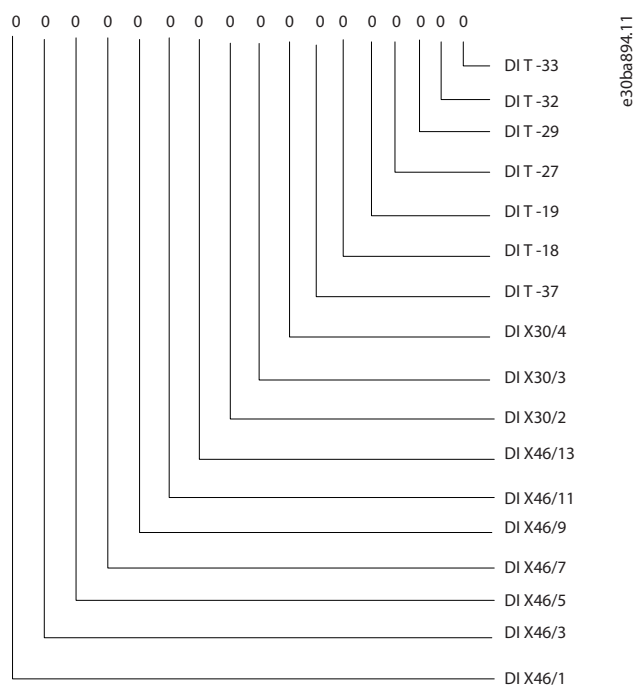

**Table 44: Parameter 16-71 Relay Output [bin]**

Range	Function
0.000 N/A* [0-511 N/A]	View the settings of all relays.

Bit 0	Relay 9
Bit 1	Relay 8
Bit 2	Relay 7
Bit 3	Relay 2
Bit 4	Relay 1
Bit 5	Relay 6
Bit 6	Relay 5
Bit 7	Relay 4
Bit 8	Relay 3
Bit 9-15	Reserved for future relays



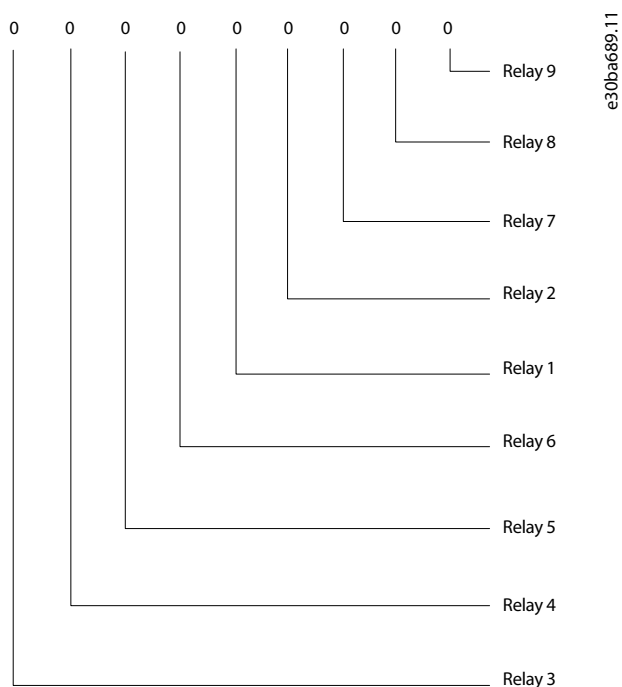

Illustration 11: Relay Outputs

Table 45: Parameter 16-78 Analog Out X45/1 [mA]

Range		Function
0*	[0–30]	Shows the actual output value at terminal X45/1. The value shown reflects the selection in <i>parameter 6-70 Terminal X45/1 Output</i> .

Table 46: Parameter 16-79 Analog Out X45/3 [mA]

Range		Function
0*	[0–30]	Shows the actual output value at terminal X45/3. The value shown reflects the selection in <i>parameter 6-80 Terminal X45/3 Output</i> .

## 5 Specifications

### 5.1 Relays

Number	4 SPDT
Load at 250 V AC/30 V DC	8 A
Load at 250 V AC/30 V DC with $\cos \varphi = 0.4$	3.5 A
Overtoltage category (contact-ground)	III
Overtoltage category (contact-contact)	II
Combination of 250 V and 24 V signals	Possible with 1 unused relay in between

### 5.2 Digital Inputs

Number	7
Range	0/24 V
Mode	PNP/NPN
Input impedance	4 k $\Omega$
Low trigger level	6.4 V
High trigger level	17 V

### 5.3 Analog Outputs

Number	2
Range	0/4–20 mA
Resolution	11 bit
Linearity	<0.2%

### 5.4 EMC

EMC	IEC 61000-6-2 and IEC 61800-3 regarding Immunity of BURST, ESD, SURGE and Conducted Immunity
-----	--

## 6 Appendix

### 6.1 Abbreviations

A	Ampere
AC	Alternating current
DC	Direct current
EMC	Electromagnetic compatibility
Hz	Hertz
V	Volt
NAMUR NE37	German recommendations, commonly used within the Chemical Industry "Realisation of Frequency Converters Standard Terminal Strip for Variable-speed Drives.
SPDT	Single pull double throw (relay).

### 6.2 Conventions

- Numbered lists indicate procedures.
- Bulleted and dashed lists indicate listings of other information where the order of the information is not relevant.
- Bolded text indicates highlighting and section headings.
- Italicized text indicates the following:
  - Cross-reference.
  - Link.
  - Footnote.
  - Parameter name.
  - Parameter option.
  - Parameter group name.
  - Alarms/warnings.
- All dimensions in drawings are in metric values (imperial values in brackets).
- An asterisk (\*) indicates the default setting of a parameter.

## Index

<b>A</b>		Unintended start .....	8
Approvals and certifications .....	6		
<b>C</b>		<b>V</b>	
Conventions .....	51	Voltage	
		Safety warning .....	8
<b>D</b>		<b>W</b>	
Digital input .....	15	Wiring .....	11, 13
Digital output .....	32		
<b>G</b>			
Galvanic isolation .....	13		
<b>L</b>			
Leakage current .....	9		
<b>M</b>			
Mounting kit .....	6		
<b>N</b>			
NAMUR .....	13		
<b>O</b>			
Order numbers .....	6		
<b>P</b>			
Purpose of the manual .....	5		
<b>Q</b>			
Qualified personnel .....	5		
<b>R</b>			
Retrofit .....	6		
<b>S</b>			
Safety instructions .....	10		
Switches			
Disconnect .....	8		
<b>U</b>			
UL certification .....	6		



ENGINEERING  
TOMORROW

*Danfoss*

.....  
Danfoss can accept no responsibility for possible errors in catalogues, brochures and other printed material. Danfoss reserves the right to alter its products without notice. This also applies to products already on order provided that such alterations can be made without subsequential changes being necessary in specifications already agreed. All trademarks in this material are property of the respective companies. Danfoss and the Danfoss logotype are trademarks of Danfoss A/S. All rights reserved.  
.....

Danfoss A/S  
Ulsnaes 1  
DK-6300 Graasten  
vlt-drives.danfoss.com

