

Design Guide

VLT® Flow Drive FC 111



VLT®
Flow Drive

Contents

1	Introduction	10
1.1	Purpose of this Design Guide	10
1.2	Additional Resources	10
1.2.1	Other Resources	10
1.2.2	MCT 10 Set-up Software Support	10
1.3	Document and Software Version	10
1.4	Regulatory Compliance	10
1.4.1	Introduction	10
1.4.2	CE Mark	10
2	Safety	12
2.1	Safety Symbols	12
2.2	Qualified Personnel	12
2.3	Safety Precautions	12
3	Product Overview	14
3.1	Advantages	14
3.1.1	Why Use a Drive for Controlling Fans and Pumps?	14
3.1.1.1	The Clear Advantage - Energy Savings	14
3.1.1.2	Example of Energy Savings	15
3.1.1.3	Comparison of Energy Savings	15
3.1.1.4	Example with Varying Flow over 1 Year	17
3.1.1.5	Better Control	18
3.1.1.6	Star/Delta Starter or Soft Starter not Required	18
3.1.1.7	Using a Drive Saves Money	18
3.1.1.8	Traditional Fan System without a Drive	19
3.1.1.9	Fan System Controlled by Drives	20
3.1.2	Application Examples	20
3.1.2.1	Variable Air Volume	20
3.1.2.2	Constant Air Volume	21
3.1.2.3	Cooling Tower Fan	22
3.1.2.4	Condenser Pumps	23
3.1.2.5	Primary Pumps	24
3.1.2.6	Secondary Pumps	25
3.1.3	Check Valve Monitoring	26
3.1.4	Dry Pump Detection	26
3.1.5	End of Curve Detection	26

3.1.6	Time-based Functions	26
3.2	Control Structures	26
3.2.1	Introduction	26
3.2.2	Control Structure Open Loop	27
3.2.3	PM/EC+ Motor Control	27
3.2.4	Local (Hand On) and Remote (Auto On) Control	27
3.2.5	Control Structure Closed Loop	28
3.2.6	Feedback Conversion	28
3.2.7	Reference Handling	28
3.2.8	Tuning the Drive Closed-loop	29
3.2.9	Adjusting the Manual PI	29
3.3	Ambient Running Conditions	30
3.3.1	Air Humidity	30
3.3.2	Acoustic Noise or Vibration	30
3.3.2.1	Acoustic Noise	30
3.3.2.2	Vibration and Shock	31
3.3.3	Aggressive Environments	31
3.4	General Aspects of EMC	31
3.4.1	Overview of EMC Emissions	31
3.4.2	Emission Requirements	32
3.4.3	EMC Emission Test Results	33
3.4.4	Harmonics Emission	34
3.4.4.1	Harmonics Emission Requirements	34
3.4.4.2	Harmonics Test Results (Emission)	35
3.4.5	Harmonics Emission Requirements	34
3.4.6	Harmonics Test Results (Emission)	36
3.4.7	Immunity Requirements	37
3.5	Galvanic Isolation (PELV)	37
3.6	Ground Leakage Current	38
3.6.1	Using a Residual Current Device (RCD)	40
3.7	Extreme Running Conditions	41
3.7.1	Introduction	41
3.7.2	Motor Thermal Protection (ETR)	42
3.7.3	Thermistor Inputs	42
3.7.3.1	Example with Digital Input and 10 V Power Supply	43
3.7.3.2	Example with Analog Input and 10 V Power Supply	43

4	Selection and Ordering	45
4.1	Type Code	45
4.2	Options and Accessories	46
4.2.1	Local Control Panel (LCP)	46
4.2.2	IP21 Enclosure Kit	46
4.2.3	Decoupling Plate	48
4.3	Ordering Numbers	49
4.3.1	Options and Accessories	49
4.3.2	Harmonic Filters	50
4.3.3	External RFI Filter	51
5	Mechanical Installation Considerations	53
5.1	Power Ratings, Weights, and Dimensions	53
5.2	Mechanical Installation H1-H8	55
5.2.1	Side-by-side Installation	55
5.3	Mechanical Installation H13-H14	56
5.3.1	Tools Needed	56
5.3.2	Installation and Cooling Requirements	56
5.3.3	Lifting the Drive	57
5.3.4	Wall Mounting the Drive	58
5.3.5	Creating Cable Openings	59
5.3.6	Back-channel Cooling	59
5.4	Derating	60
5.4.1	Manual Derating and Automatic Derating	60
5.4.2	Derating for Low-speed Operation	60
5.4.3	Derating for Low Air Pressure and High Altitudes	60
5.4.4	Derating for Ambient Temperature and Switching Frequency	60
6	Electrical Installation Considerations	63
6.1	Safety Instructions	63
6.2	Electrical Wiring	64
6.3	EMC-compliant Electrical Installation	64
6.4	Relays and Terminals	66
6.4.1	Relays and Terminals on Enclosure Sizes H1–H5	66
6.4.2	Relays and Terminals on Enclosure Size H6	67
6.4.3	Relays and Terminals on Enclosure Size H7	67
6.4.4	Relays and Terminals on Enclosure Size H8	68
6.4.5	Relays and Terminals on Enclosure Size H13–H14	69
6.5	View of Control Shelf	69

6.6	Fastener Tightening Torques	70
6.7	IT Mains	71
6.8	Mains and Motor Connection	72
6.8.1	Introduction	72
6.8.2	Connecting to the Ground	72
6.8.3	Connecting the Motor	73
6.8.4	Connecting the AC Mains	73
6.9	Fuses and Circuit Breakers	73
6.9.1	Branch Circuit Protection	73
6.9.2	Short-circuit Protection	73
6.9.3	Overcurrent Protection	74
6.9.4	CE Compliance	74
6.9.5	Recommendation of Fuses and Circuit Breakers	74
6.10	Control Terminals	75
6.11	Efficiency	76
6.11.1	Efficiency of the Drive	76
6.11.2	Efficiency of the Motor	77
6.11.3	Efficiency of the System	77
6.12	dU/dt Conditions	77
6.12.1	dU/dt Overview	77
6.12.2	dU/dt Test Results for H1–H8	77
6.12.3	High-power Range	80
6.12.4	dU/dt Test Results for H13–H14	80
7	Programming	81
7.1	Local Control Panel (LCP)	81
7.2	Menus	82
7.2.1	Status Menu	82
7.2.2	Quick Menu	82
7.2.2.1	Quick Menu Introduction	82
7.2.2.2	Setup Wizard Introduction	83
7.2.2.3	Setup Wizard for Open-loop Applications	84
7.2.2.4	Setup Wizard for Closed-loop Applications	89
7.2.2.5	Motor Setup	94
7.2.2.6	Changes Made Function	97
7.2.2.7	Changing Parameter Settings	98
7.2.2.8	Accessing All Parameters via the Main Menu	98
7.2.3	Main Menu	98

7.3	Quick Transfer of Parameter Settings between Multiple Drives	98
7.3.1	Transferring Data from the Drive to the LCP	98
7.3.2	Transferring Data from the LCP to the Drive	98
7.4	Readout and Programming of Indexed Parameters	99
7.5	Initialization to Default Settings	99
7.5.1	Recommended Initialization	99
7.5.2	Two-finger Initialization	99
8	RS485 Installation and Set-up	101
8.1	RS485	101
8.1.1	Overview	101
8.1.2	Connecting the Drive to the RS485 Network	102
8.1.3	Hardware Set-up	102
8.1.4	Parameter Settings for Modbus Communication	103
8.1.5	EMC Precautions	103
8.2	FC Protocol	104
8.2.1	Overview	104
8.2.2	FC with Modbus RTU	104
8.3	Network Configuration	105
8.4	FC Protocol Message Framing Structure	105
8.4.1	Content of a Character (byte)	105
8.4.2	Telegram Structure	105
8.4.3	Telegram Length (LGE)	105
8.4.4	Drive Address (ADR)	106
8.4.5	Data Control Byte (BCC)	106
8.4.6	The Data Field	106
8.4.7	The PKE Field	107
8.4.8	Parameter Number (PNU)	108
8.4.9	Index (IND)	108
8.4.10	Parameter Value (PWE)	108
8.4.11	Data Types Supported by the Drive	109
8.4.12	Conversion	109
8.4.13	Process Words (PCD)	110
8.5	Examples	110
8.5.1	Writing a Parameter Value	110
8.5.2	Reading a Parameter Value	110
8.6	Modbus RTU	111
8.6.1	Prerequisite Knowledge	111

8.6.2	Modbus RTU Overview	111
8.6.3	Drive with Modbus RTU	111
8.7	Network Configuration	112
8.8	Modbus RTU Message Framing Structure	112
8.8.1	Modbus RTU Message Byte Format	112
8.8.2	Modbus RTU Telegram Structure	113
8.8.3	Start/Stop Field	113
8.8.4	Address Field	113
8.8.5	Function Field	113
8.8.6	Data Field	113
8.8.7	CRC Check Field	113
8.8.8	Coil Register Addressing	114
8.8.8.1	Introduction	114
8.8.8.2	Coil Register	114
8.8.8.3	Drive Control Word (FC Profile)	114
8.8.8.4	Drive Status Word (FC Profile)	115
8.8.8.5	Address/Registers	115
8.8.9	Access via PCD Write/read	116
8.8.10	How to Control the Drive	117
8.8.10.1	Introduction	117
8.8.10.2	Function Codes Supported by Modbus RTU	117
8.8.10.3	Modbus Exception Codes	118
8.9	How to Access Parameters	118
8.9.1	Parameter Handling	118
8.9.2	Storage of Data	118
8.9.3	IND (Index)	119
8.9.4	Text Blocks	119
8.9.5	Conversion Factor	119
8.9.6	Parameter Values	119
8.10	Examples	119
8.10.1	Introduction	119
8.10.2	Read Coil Status (01 hex)	119
8.10.3	Force/Write Single Coil (05 hex)	120
8.10.4	Force/Write Multiple Coils (0F hex)	121
8.10.5	Read Holding Registers (03 hex)	122
8.10.6	Preset Single Register (06 hex)	122
8.10.7	Preset Multiple Registers (10 hex)	123
8.10.8	Read/Write Multiple Registers (17 hex)	124

8.11	Danfoss FC Control Profile	125
8.11.1	Control Word According to FC Profile (8-10 Protocol = FC Profile)	125
8.11.2	Explanation of Each Control Bit	126
8.11.3	Status Word According to FC Profile (STW)	128
8.11.4	Explanation of Each Status Bit	128
8.11.5	Bus Speed Reference Value	130
9	General Specifications	131
9.1	Mains Supply	131
9.1.1	3x380–480 V AC	131
9.2	General Technical Data	133
9.2.1	Protection and Features	133
9.2.2	Mains Supply	133
9.2.3	Motor Output (U, V, W)	133
9.2.4	Cable Length and Cross-section	134
9.2.5	Digital Inputs	134
9.2.6	Analog Inputs	134
9.2.7	Analog Outputs	135
9.2.8	Digital Output	135
9.2.9	RS485 Serial Communication	135
9.2.10	24 V DC Output	135
9.2.11	Relay Output	135
9.2.12	10 V DC Output	136
9.2.13	Ambient Conditions (H1–H8)	136
9.2.14	Ambient Conditions (H13–H14)	137
10	Appendix	138
10.1	Abbreviations	138
10.2	Definitions	139
10.2.1	AC Drive	139
10.2.2	Input	139
10.2.3	Motor	139
10.2.4	References	141
10.2.5	Miscellaneous	141

1 Introduction

1.1 Purpose of this Design Guide

This Design Guide is intended for qualified personnel, such as:

- Project and systems engineers.
- Design consultants.
- Application and product specialists.

The Design Guide provides technical information to understand the capabilities of the VLT® Flow Drive FC 111 for integration into motor control and monitoring systems. Its purpose is to provide design considerations and planning data for integration of the drive into a system. It caters for selection of drives and options for a diversity of applications and installations. Reviewing the detailed product information in the design stage enables developing a well-conceived system with optimal functionality and efficiency.

This manual is targeted at a worldwide audience. Therefore, wherever occurring, both SI and imperial units are shown.

VLT® is a registered trademark for Danfoss A/S.

1.2 Additional Resources

1.2.1 Other Resources

Other resources are available to understand advanced drive functions and programming.

- VLT® Flow Drive FC 111 Operating Guide provides basic information on mechanical dimensions, installation, and programming.
- VLT® Flow Drive FC 111 Programming Guide provides information on how to program, and includes complete parameter descriptions.
- Danfoss VLT® Energy Box software. Select PC Software Download at www.danfoss.com.

VLT® Energy Box software allows energy consumption comparisons of HVAC fans and pumps driven by Danfoss drives and alternative methods of flow control. Use this tool to accurately project the costs, savings, and payback of using Danfoss drives on HVAC fans, pumps, and cooling towers.

Supplementary publications and manuals are available from Danfoss website www.danfoss.com.

1.2.2 MCT 10 Set-up Software Support

Download the software from the service and support section on www.danfoss.com.

During the installation process of the software, enter access code 81462700 to activate the VLT® Flow Drive FC 111 functionality. A license key is not required for using the VLT® Flow Drive FC 111 functionality.

The latest software does not always contain the latest updates for drives. Contact the local sales office for the latest drive updates (in the form of *.OSS files).

1.3 Document and Software Version

This guide is regularly reviewed and updated. All suggestions for improvement are welcome.

The original language of this manual is English.

Table 1: Document and Software Version

Edition	Remarks	Software version
AJ363928382091, version 0101	First edition.	65.00

1.4 Regulatory Compliance

1.4.1 Introduction

AC drives are designed in compliance with the directives described in this section.

1.4.2 CE Mark

The CE mark (Communauté Européenne) indicates that the product manufacturer conforms to all applicable EU directives. The EU directives applicable to the design and manufacture of drives are listed in the following table.

N O T I C E

The CE mark does not regulate the quality of the product. Technical specifications cannot be deduced from the CE mark.

N O T I C E

Drives with an integrated safety function must comply with the machinery directive.

Table 2: EU Directives Applicable to Drives

EU directive	Version
Low Voltage Directive	2014/35/EU
EMC Directive	2014/30/EU
ErP Directive	

Declarations of conformity are available on request.

1.4.2.1 Low Voltage Directive

The aim of the Low Voltage Directive is to protect persons, domestic animals and property against dangers caused by the electrical equipment, when operating electrical equipment that is installed and maintained correctly, in its intended application. The directive applies to all electrical equipment in the 50–1000 V AC and the 75–1500 V DC voltage ranges.

1.4.2.2 EMC Directive

The purpose of the EMC (electromagnetic compatibility) Directive is to reduce electromagnetic interference and enhance immunity of electrical equipment and installations. The basic protection requirement of the EMC Directive states that devices that generate electromagnetic interference (EMI), or whose operation could be affected by EMI, must be designed to limit the generation of electromagnetic interference and shall have a suitable degree of immunity to EMI when properly installed, maintained, and used as intended. Electrical equipment devices used alone or as part of a system must bear the CE mark. Systems do not require the CE mark, but must comply with the basic protection requirements of the EMC Directive.

1.4.2.3 ErP Directive

The ErP Directive is the European Ecodesign Directive for energy-related products. The directive sets ecodesign requirements for energy-related products, including drives, and aims at reducing the energy consumption and environmental impact of products by establishing minimum energy-efficiency standards.

2 Safety

2.1 Safety Symbols

The following symbols are used in this manual:

⚠ D A N G E R ⚠

Indicates a hazardous situation which, if not avoided, will result in death or serious injury.

⚠ W A R N I N G ⚠

Indicates a hazardous situation which, if not avoided, could result in death or serious injury.

⚠ C A U T I O N ⚠

Indicates a hazardous situation which, if not avoided, could result in minor or moderate injury.

N O T I C E

Indicates information considered important, but not hazard-related (for example, messages relating to property damage).

2.2 Qualified Personnel

To allow trouble-free and safe operation of the unit, only qualified personnel with proven skills are allowed to transport, store, assemble, install, program, commission, maintain, and decommission this equipment.

Persons with proven skills:

- Are qualified electrical engineers, or persons who have received training from qualified electrical engineers and are suitably experienced to operate devices, systems, plant, and machinery in accordance with pertinent laws and regulations.
- Are familiar with the basic regulations concerning health and safety/accident prevention.
- Have read and understood the safety guidelines given in all manuals provided with the unit, especially the instructions given in the Operating Guide.
- Have good knowledge of the generic and specialist standards applicable to the specific application.

2.3 Safety Precautions

⚠ W A R N I N G

HAZARDOUS VOLTAGE

AC drives contain hazardous voltage when connected to the AC mains or connected on the DC terminals. Failure to perform installation, start-up, and maintenance by skilled personnel can result in death or serious injury.

- Only skilled personnel must perform installation, start-up, and maintenance.

⚠ W A R N I N G ⚠

UNINTENDED START

When the drive is connected to AC mains, DC supply, or load sharing, the motor may start at any time. Unintended start during programming, service, or repair work can result in death, serious injury, or property damage. Start the motor with an external switch, a fieldbus command, an input reference signal from the local control panel (LCP), via remote operation using MCT 10 software, or after a cleared fault condition.

- Disconnect the drive from the mains.
- Press [Off/Reset] on the LCP before programming parameters.
- Ensure that the drive is fully wired and assembled when it is connected to AC mains, DC supply, or load sharing.

⚠ W A R N I N G ⚠

DISCHARGE TIME

The drive contains DC-link capacitors, which can remain charged even when the drive is not powered. High voltage can be present even when the warning indicator lights are off.

Failure to wait the specified time after power has been removed before performing service or repair work could result in death or serious injury.

- Stop the motor.
- Disconnect AC mains, permanent magnet type motors, and remote DC-link supplies, including battery back-ups, UPS, and DC-link connections to other drives.
- Wait for the capacitors to discharge fully. The minimum waiting time is specified in the table *Discharge time* and is also visible on the nameplate on the top of the drive.
- Before performing any service or repair work, use an appropriate voltage measuring device to make sure that the capacitors are fully discharged.

Table 3: Discharge Time

Voltage [V]	Power range [kW (hp)]	Minimum waiting time (minutes)
3x400	0.37–7.5 (0.5–10)	4
3x400	11–90 (15–125)	15
3x400	110–315 (150–450)	20

⚠ W A R N I N G

LEAKAGE CURRENT HAZARD

Leakage currents exceed 3.5 mA. Failure to ground the drive properly can result in death or serious injury.

- Ensure that the minimum size of the ground conductor complies with the local safety regulations for high touch current equipment.

⚠ W A R N I N G ⚠

EQUIPMENT HAZARD

Contact with rotating shafts and electrical equipment can result in death or serious injury.

- Ensure that only trained and qualified personnel perform installation, start-up, and maintenance.
- Ensure that electrical work conforms to national and local electrical codes.
- Follow the procedures in this manual.

⚠ C A U T I O N ⚠

INTERNAL FAILURE HAZARD

An internal failure in the drive can result in serious injury when the drive is not properly closed.

- Ensure that all safety covers are in place and securely fastened before applying power.

3 Product Overview

3.1 Advantages

3.1.1 Why Use a Drive for Controlling Fans and Pumps?

A drive takes advantage of the fact that centrifugal fans and pumps follow the laws of proportionality for such fans and pumps. For further information, see [3.1.1.2 Example of Energy Savings](#).

3.1.1.1 The Clear Advantage - Energy Savings

The clear advantage of using a drive for controlling the speed of fans or pumps lies in the electricity savings.

When comparing with alternative control systems and technologies, a drive is the optimum energy control system for controlling fan and pump systems.

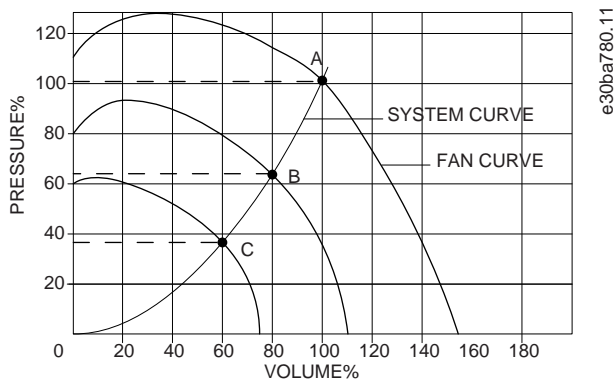

Illustration 1: Fan Curves (A, B, and C) for Reduced Fan Volumes

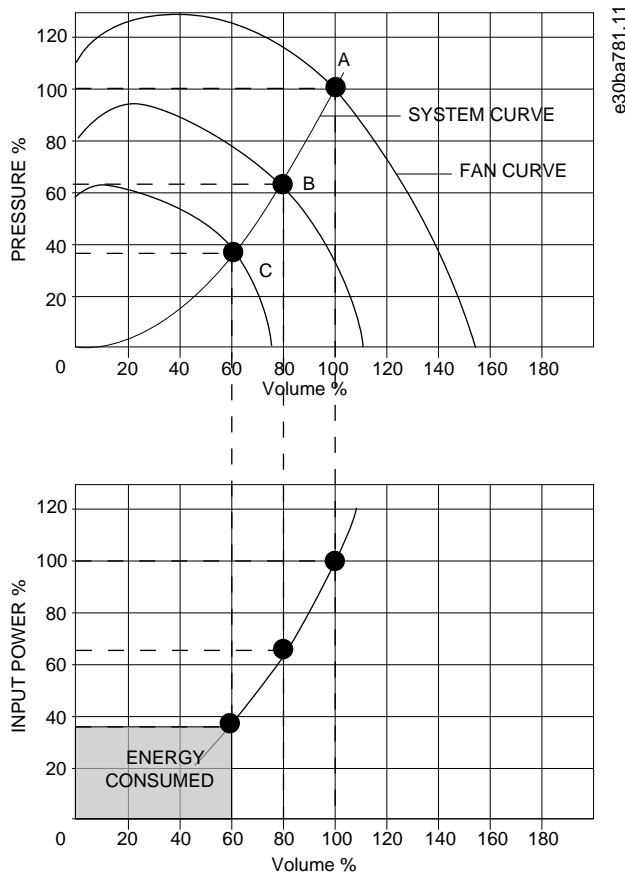

Illustration 2: Energy Savings with Drive Solution

When using a drive to reduce fan capacity to 60% - more than 50% energy savings may be obtained in typical applications.

3.1.1.2 Example of Energy Savings

As shown in the following illustration, the flow is controlled by changing the RPM. By reducing the speed by only 20% from the rated speed, the flow is also reduced by 20%. This is because the flow is directly proportional to the RPM. The consumption of electricity, however, is reduced by 50%.

If the system in question only needs to be able to supply a flow that corresponds to 100% a few days in a year, while the average is below 80% of the rated flow for the remainder of the year, the amount of energy saved is even more than 50%.

The following illustration describes the dependence of flow, pressure, and power consumption on RPM.

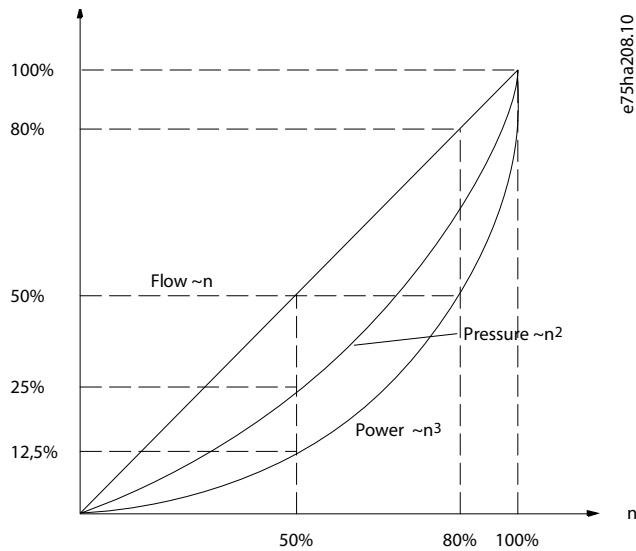

Illustration 3: Laws of Proportionality

$$\text{Flow : } \frac{Q_1}{Q_2} = \frac{n_1}{n_2}$$

$$\text{Pressure : } \frac{H_1}{H_2} = \left(\frac{n_1}{n_2}\right)^2$$

$$\text{Power : } \frac{P_1}{P_2} = \left(\frac{n_1}{n_2}\right)^3$$

Table 4: The Laws of Proportionality

Q = Flow	P = Power
Q ₁ = Rated flow	P ₁ = Rated power
Q ₂ = Reduced flow	P ₂ = Reduced power
H = Pressure	n = Speed control
H ₁ = Rated pressure	n ₁ = Rated speed
H ₂ = Reduced pressure	n ₂ = Reduced speed

3.1.1.3 Comparison of Energy Savings

The Danfoss drive solution offers major savings compared with traditional energy saving solutions such as discharge damper solution and inlet guide vanes (IGV) solution. This is because the drive is able to control fan speed according to thermal load on the system, and the drive has a built-in facility that enables the drive to function as a building management system, BMS.

The illustration in [3.1.1.2 Example of Energy Savings](#) shows typical energy savings obtainable with 3 well-known solutions when fan volume is reduced to 60%. As the graph shows, more than 50% energy savings can be achieved in typical applications.

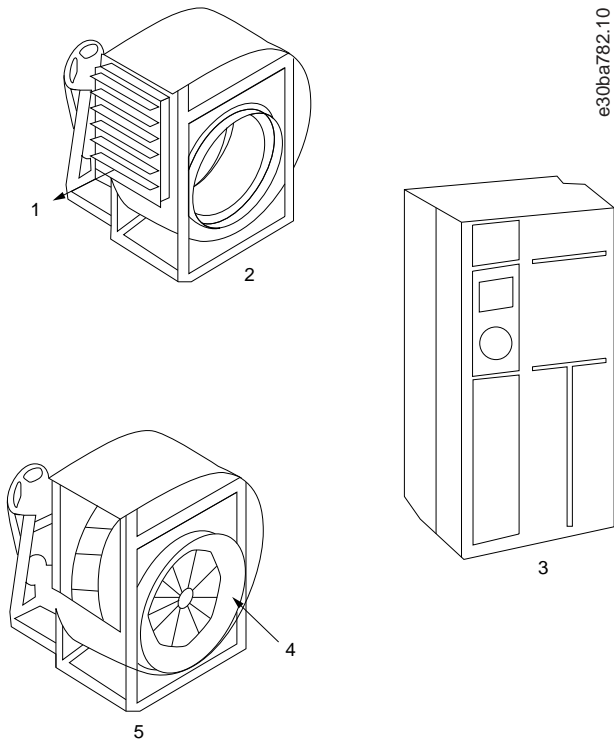

Illustration 4: The 3 Common Energy Saving Systems

1	Discharge damper	4	IGV
2	Less energy savings	5	Costlier installation
3	Maximum energy savings		

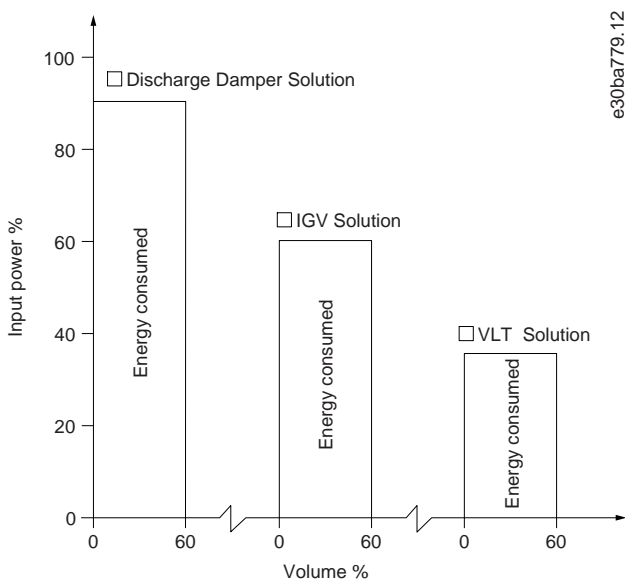

Illustration 5: Energy Savings

Discharge dampers reduce power consumption. Inlet guide vanes offer a 40% reduction, but are expensive to install. The Danfoss drive solution reduces energy consumption with more than 50% and is easy to install. It also reduces noise, mechanical stress, and wear-and-tear, and extends the life span of the entire application.

3.1.1.4 Example with Varying Flow over 1 Year

This example is calculated based on pump characteristics obtained from a pump datasheet. The result obtained shows energy savings of more than 50% at the given flow distribution over a year. The payback period depends on the price per kWh and the price of drive. In this example, it is less than a year when compared with valves and constant speed.

Energy savings

$$P_{\text{shaft}} = P_{\text{shaft output}}$$

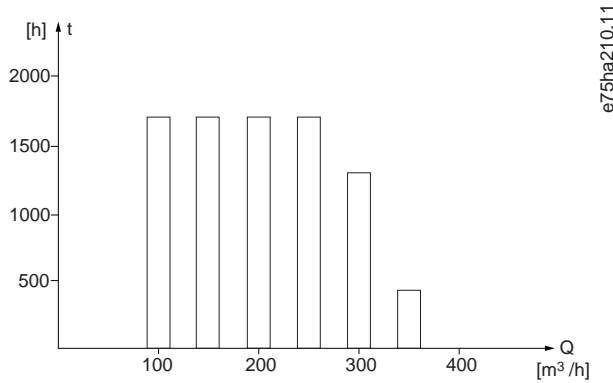

Illustration 6: Flow Distribution over 1 Year

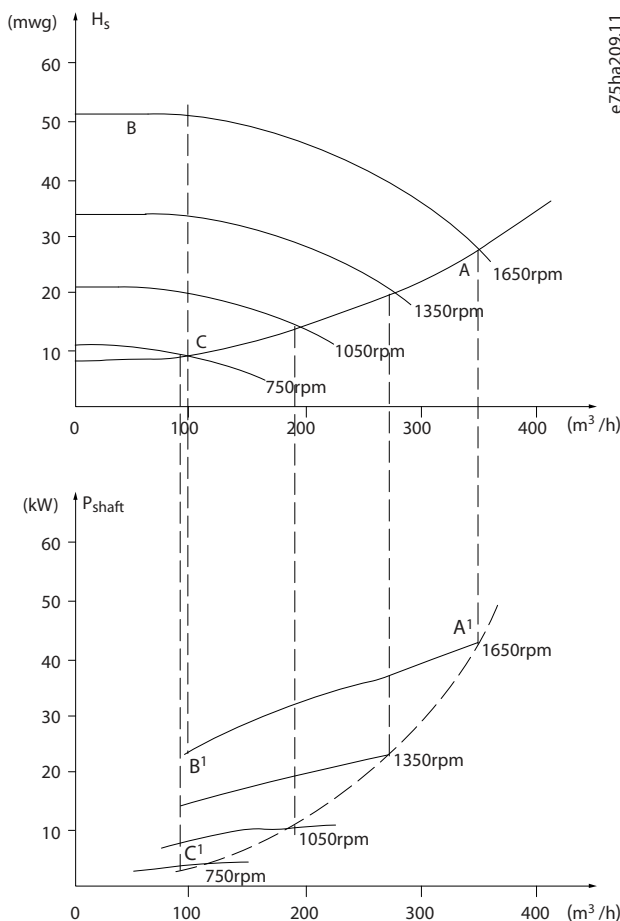

Illustration 7: Energy

Table 5: Result

m³/h	Distribution		Valve regulation		Drive control	
	%	Hours	Power	Consumption	Power	Consumption
			A ₁ - B ₁	kWh	A ₁ - C ₁	kWh

350	5	438	42.5	18.615	42.5	18.615
300	15	1314	38.5	50.589	29.0	38.106
250	20	1752	35.0	61.320	18.5	32.412
200	20	1752	31.5	55.188	11.5	20.148
150	20	1752	28.0	49.056	6.5	11.388
100	20	1752	23.0	40.296	3.5	6.132
Σ	100	8760	–	275.064	–	26.801

3.1.1.5 Better Control

If a drive is used for controlling the flow or pressure of a system, improved control is obtained.

A drive can vary the speed of the fan or pump, obtaining variable control of flow and pressure. Furthermore, a drive can quickly adapt the speed of the fan or pump to new flow or pressure conditions in the system.

Simple control of process (flow, level, or pressure) utilizing the built-in PI control.

3.1.1.6 Star/Delta Starter or Soft Starter not Required

When larger motors are started, it is necessary in many countries to use equipment that limits the start-up current. In more traditional systems, a star/delta starter or soft starter is widely used. Such motor starters are not required if a drive is used.

As shown in the following illustration, a drive does not consume more than rated current.

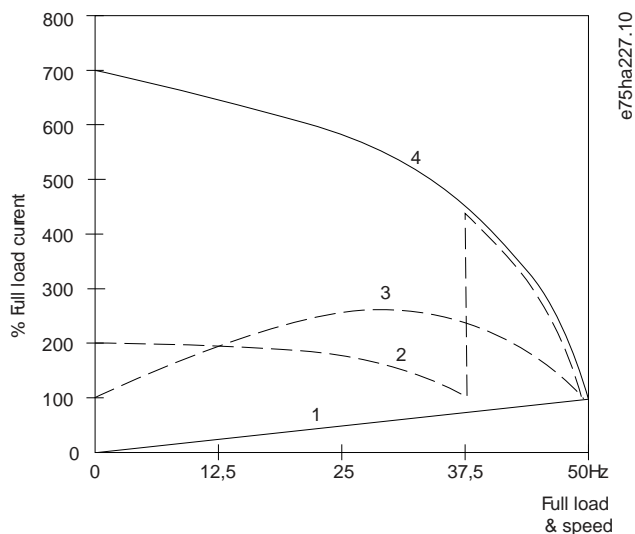

Illustration 8: Start-up Current

1	VLT® Flow Drive FC 111	3	Soft starter
2	Star/delta starter	4	Start directly on mains

3.1.1.7 Using a Drive Saves Money

The example in [3.1.1.8 Traditional Fan System without a Drive](#) and [3.1.1.9 Fan System Controlled by Drives](#) shows that a drive replaces other equipment. It is possible to calculate the cost of installing the 2 different systems. In the example, the 2 systems can be established at roughly the same price.

Use the VLT® Energy Box software that is introduced in *chapter Additional Resources* to calculate the cost savings that can be achieved by using a drive.

3.1.1.8 Traditional Fan System without a Drive

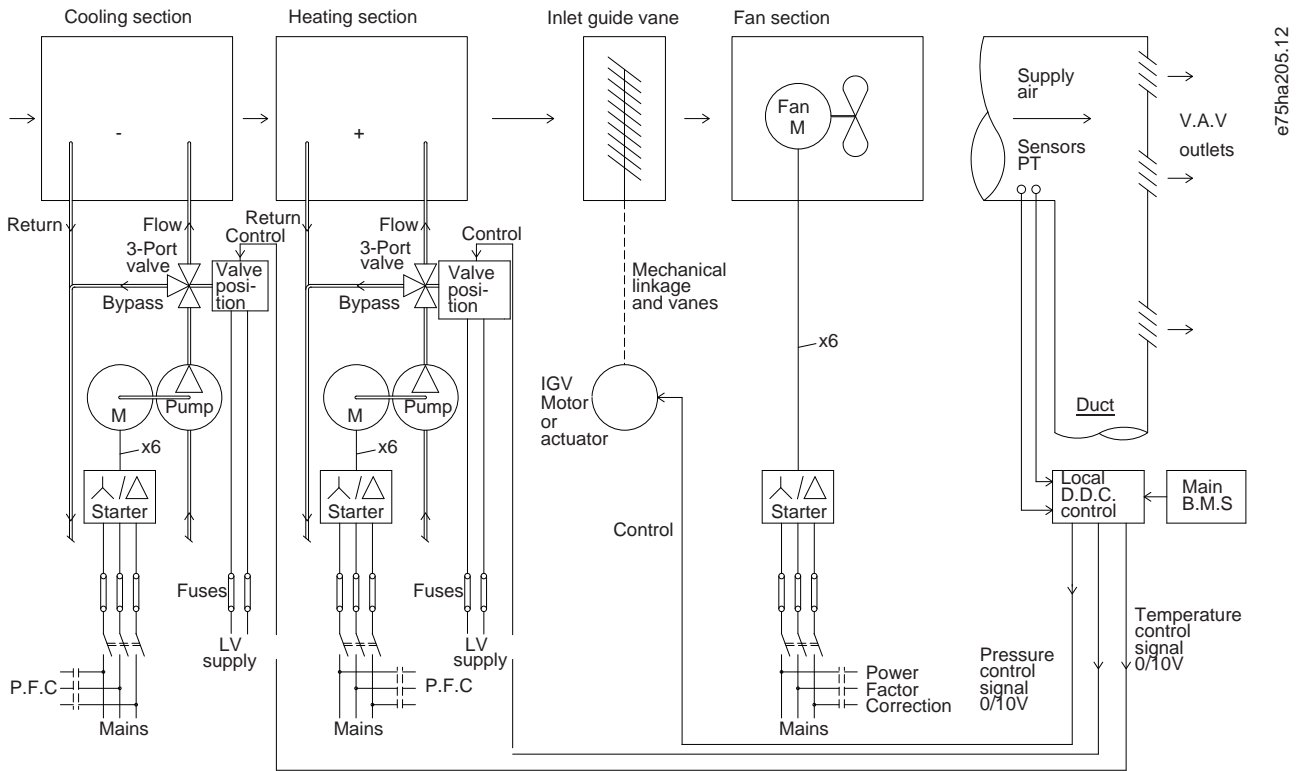
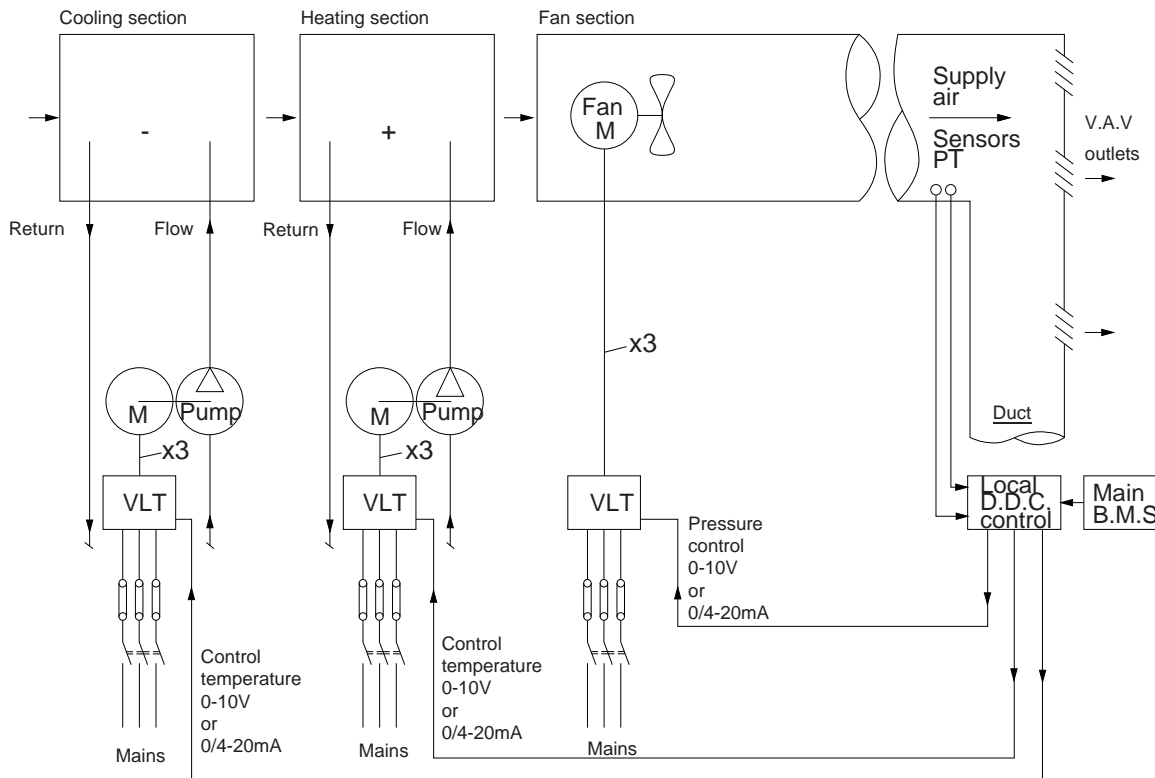

Illustration 9: Traditional Fan System without a Drive

D.D.C.	Direct digital control	Sensor	Pressure
E.M.S.	Energy management system	P	
V.A.V.	Variable air volume	Sensor	Temperature
		T	

3.1.1.9 Fan System Controlled by Drives



e75ha206.11

Illustration 10: Fan System Controlled by Drives

D.D.C.	Direct digital control	Sensor	Pressure
E.M.S.	Energy management system	P	
V.A.V.	Variable air volume	Sensor	Temperature
		T	

3.1.2 Application Examples

The following sections give typical examples of applications.

3.1.2.1 Variable Air Volume

VAV or variable air volume systems, control both the ventilation and temperature to satisfy the requirements of a building. Central VAV systems are considered to be the most energy efficient method to air condition buildings. By designing central systems instead of distributed systems, a greater efficiency can be obtained.

The efficiency comes from utilizing larger fans and larger chillers which have much higher efficiencies than small motors and distributed air-cooled chillers. Savings are also seen from the decreased maintenance requirements.

The VLT Solution

While dampers and IGVs work to maintain a constant pressure in the ductwork, a drive solution saves much more energy and reduces the complexity of the installation. Instead of creating an artificial pressure drop or causing a decrease in fan efficiency, the drive decreases the speed of the fan to provide the flow and pressure required by the system.

Centrifugal devices such as fans behave according to the centrifugal laws. This means that the fans decrease the pressure and flow they produce as their speed is reduced. Their power consumption is thereby significantly reduced. The PI controller of the drive can be used to eliminate the need for additional controllers.

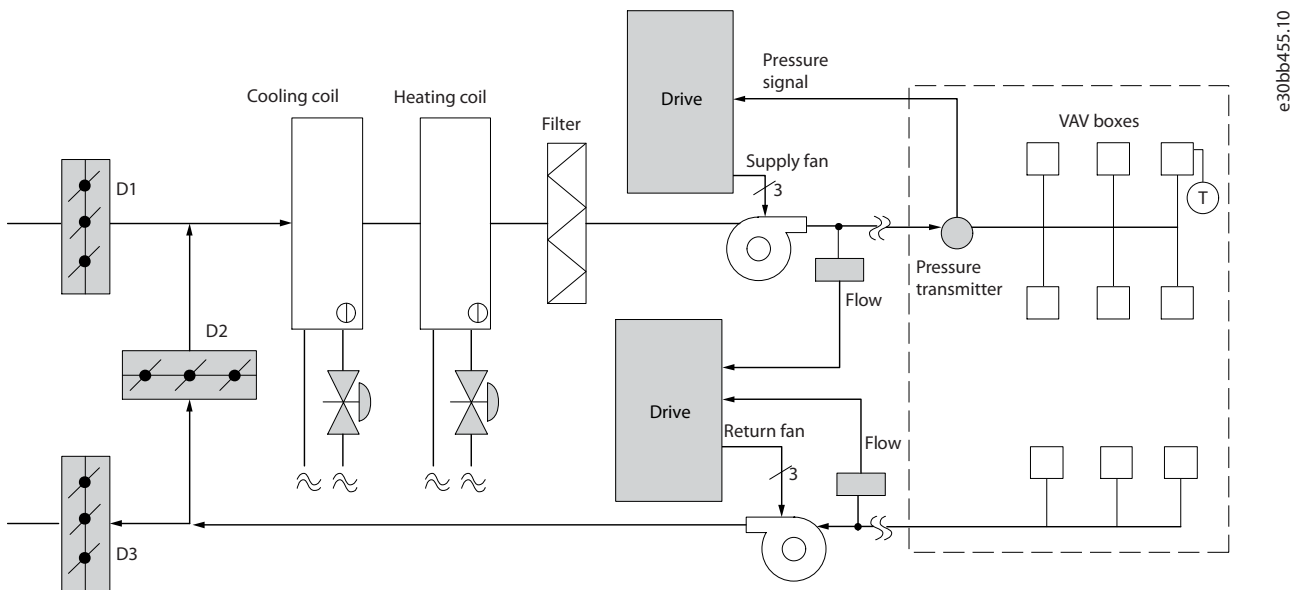

Illustration 11: Variable Air Volume

3.1.2.2 Constant Air Volume

CAV, or constant air volume systems, are central ventilation systems usually used to supply large common zones with the minimum amounts of fresh tempered air. They preceded VAV systems and are therefore found in older multi-zoned commercial buildings as well. These systems preheat amounts of fresh air utilizing air handling units (AHUs) with a heating coil, and many are also used to air condition buildings and have a cooling coil. Fan coil units are frequently used to assist in the heating and cooling requirements in the individual zones.

The VLT Solution

With a drive, significant energy savings can be obtained while maintaining decent control of the building. Temperature sensors or CO₂ sensors can be used as feedback signals to drives. Whether controlling temperature, air quality, or both, a CAV system can be controlled to operate based on actual building conditions. As the number of people in the controlled area decreases, the need for fresh air decreases. The CO₂ sensor detects lower levels and decreases the supply fans speed. The return fan modulates to maintain a static pressure setpoint or fixed difference between the supply and return airflows.

With temperature control, especially used in air conditioning systems, as the outside temperature varies as well as the number of people in the controlled zone changes, different cooling requirements exist. As the temperature decreases below the setpoint, the supply fan can decrease its speed. The return fan modulates to maintain a static pressure setpoint. By decreasing the air flow, energy used to heat or cool the fresh air is also reduced, adding further savings.

Several features of the Danfoss dedicated drive can be utilized to improve the performance of the CAV system. One concern of controlling a ventilation system is poor air quality. The programmable minimum frequency can be set to maintain a minimum amount of supply air regardless of the feedback or reference signal. The drive also includes a PI controller, which allows monitoring both temperature and air quality. Even if the temperature requirement is fulfilled, the drive maintains enough supply air to satisfy the air quality sensor. The controller is capable of monitoring and comparing 2 feedback signals to control the return fan by maintaining a fixed differential airflow between the supply and return ducts as well.

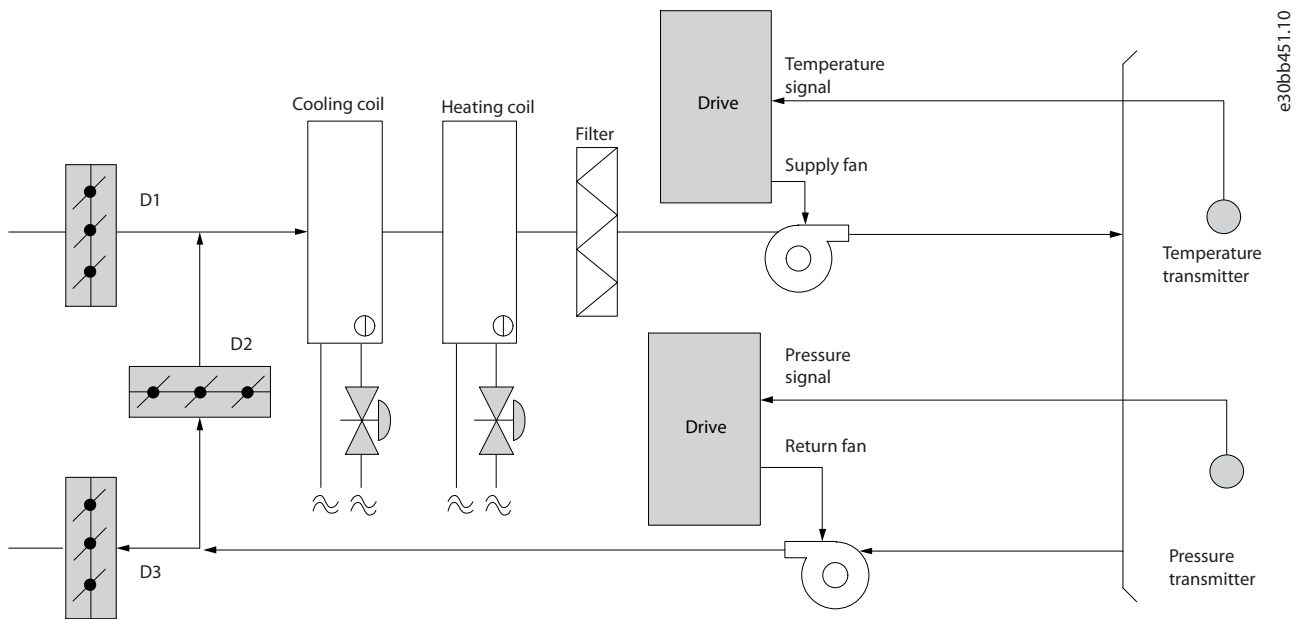

Illustration 12: Constant Air Volume

3.1.2.3 Cooling Tower Fan

Cooling tower fans cool condenser-water in water-cooled chiller systems. Water-cooled chillers provide the most efficient means of creating chilled water. They are as much as 20% more efficient than air cooled chillers. Depending on climate, cooling towers are often the most energy efficient method of cooling the condenser-water from chillers.

They cool the condenser water by evaporation. The condenser water is sprayed into the cooling tower until the cooling towers fill to increase its surface area. The tower fan blows air through the fill and sprayed water to aid in the evaporation. Evaporation removes energy from the water dropping its temperature. The cooled water collects in the cooling towers basin where it is pumped back into the chillers condenser and the cycle is repeated.

The VLT Solution

With a drive, the cooling towers fans can be controlled to the required speed to maintain the condenser-water temperature. The drives can also be used to turn the fan on and off as needed.

Several features of the Danfoss dedicated drive can be utilized to improve the performance of cooling tower fans applications. As the cooling tower fans drop below a certain speed, the effect the fan has on cooling the water becomes small. Also, when utilizing a gearbox to frequency control the tower fan, a minimum speed of 40–50% is required.

The customer programmable minimum frequency setting is available to maintain this minimum frequency even as the feedback or speed reference calls for lower speeds.

Also as a standard feature, the drive can be programmed to enter a sleep mode and stop the fan until a higher speed is required. Additionally, some cooling tower fans have undesirable frequencies that may cause vibrations. These frequencies can easily be avoided by programming the bypass frequency ranges in the drive.

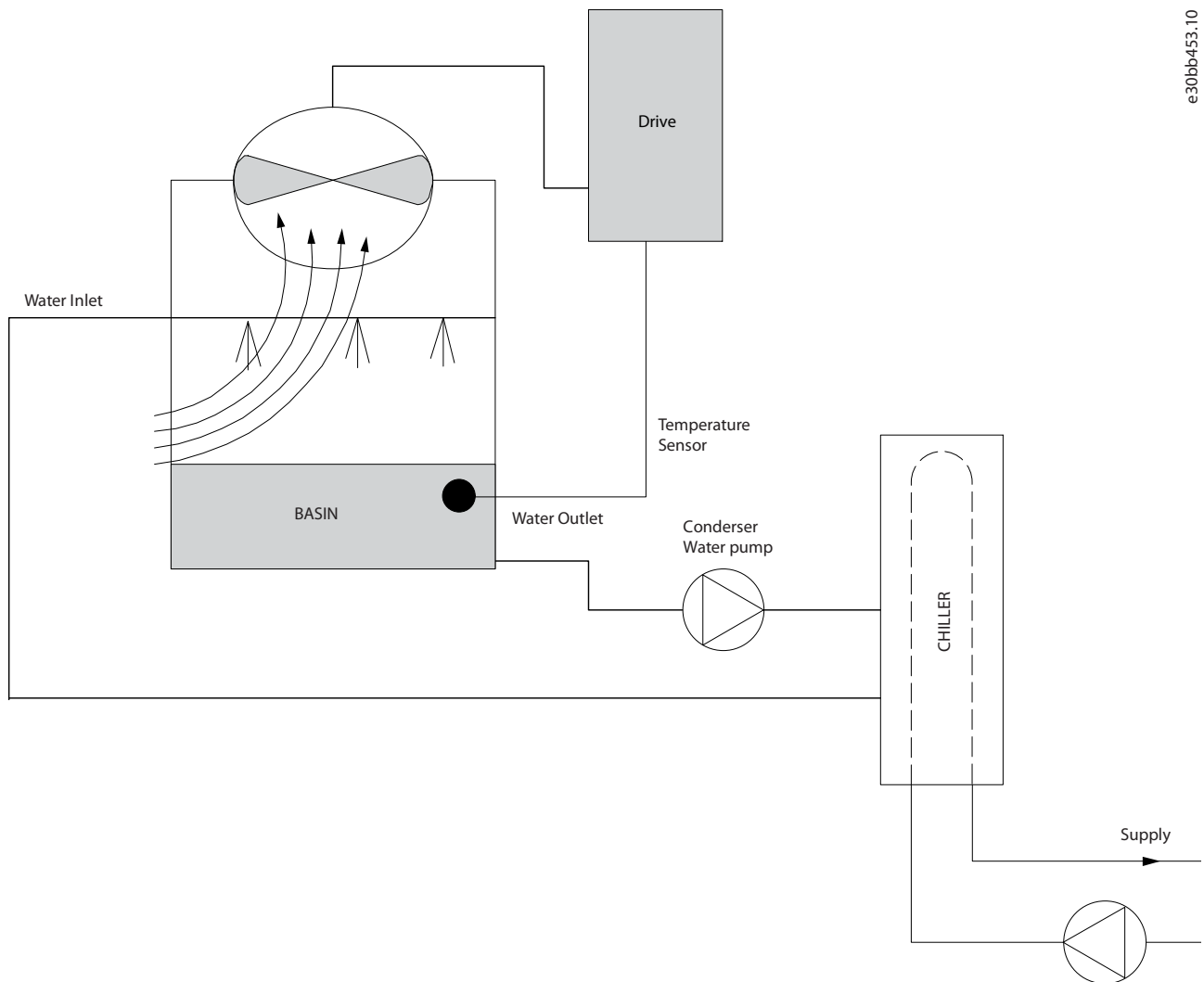

e30bb453.10

Illustration 13: Cooling Tower Fan

3.1.2.4 Condenser Pumps

Condenser water pumps are primarily used to circulate water through the condenser section of water cooled chillers and their associated cooling tower. The condenser water absorbs the heat from the chiller's condenser section and releases it into the atmosphere in the cooling tower. These systems are used to provide the most efficient means of creating chilled water, they are as much as 20% more efficient than air cooled chillers.

The VLT Solution

Drives can be added to condenser water pumps instead of balancing the pumps with a throttling valve or trimming the pump impeller.

Using a drive instead of a throttling valve simply saves the energy that would have been absorbed by the valve. This can amount to savings of 15–20% or more. Trimming the pump impeller is irreversible, thus if the conditions change and higher flow is required the impeller must be replaced.

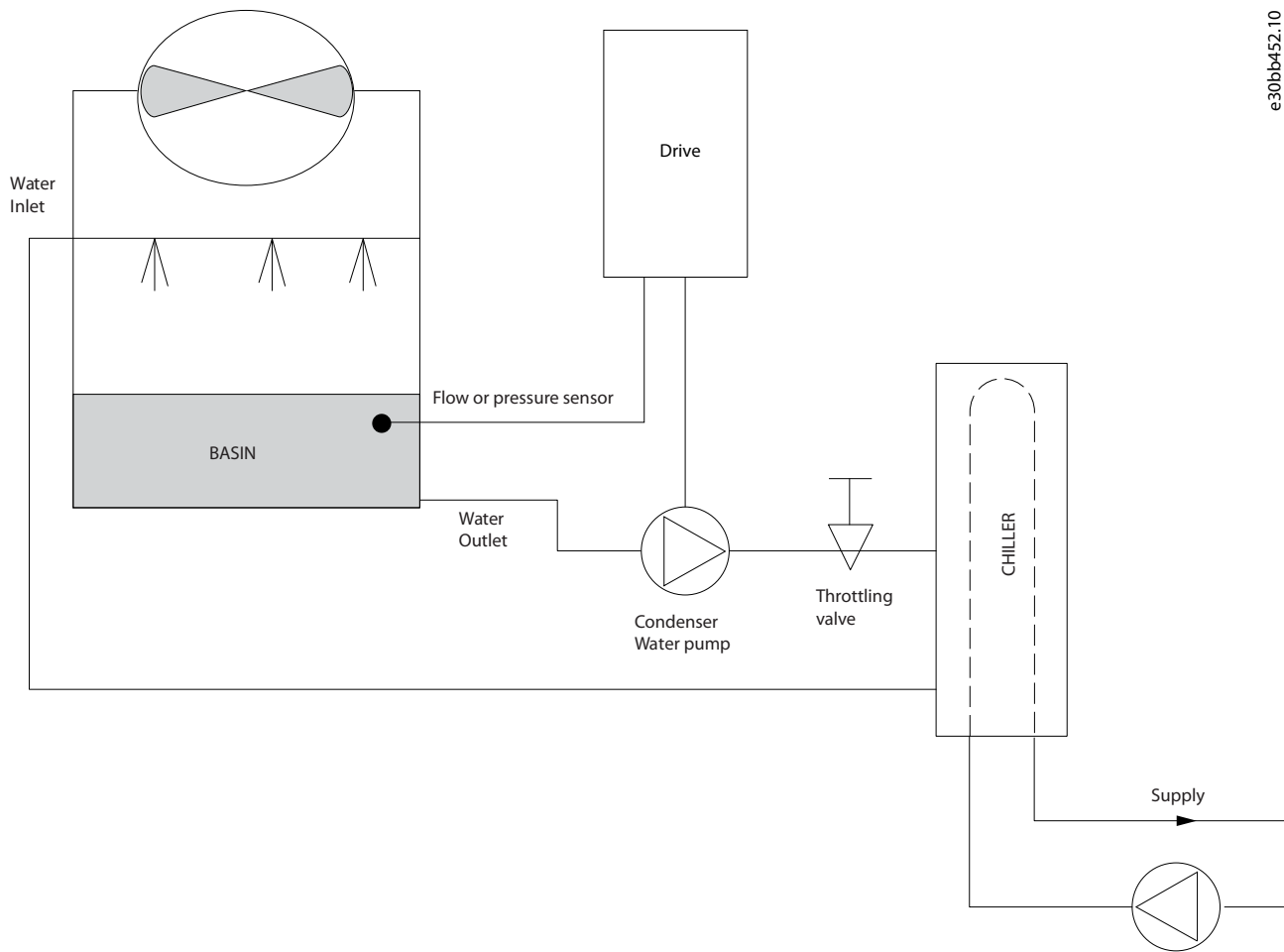

e30bb452.10

Illustration 14: Condenser Pumps

3.1.2.5 Primary Pumps

Primary pumps in a primary/secondary pumping system can be used to maintain a constant flow through devices that encounter operation or control difficulties when exposed to variable flow. The primary/secondary pumping technique decouples the primary production loop from the secondary distribution loop. This allows devices such as chillers to obtain constant design flow and operate properly while allowing the rest of the system to vary in flow.

As the evaporator flow rate decreases in a chiller, the chilled water begins to become overchilled. As this happens, the chiller attempts to decrease its cooling capacity. If the flow rate drops far enough, or too quickly, the chiller cannot shed its load sufficiently and the chiller’s safety trips the chiller requiring a manual reset. This situation is common in large installations especially when 2 or more chillers in parallel are installed if primary/ secondary pumping is not utilized.

The VLT Solution

Depending on the size of the system and the size of the primary loop, the energy consumption of the primary loop can become substantial.

A drive can be added to the primary system to replace the throttling valve and/or trimming of the impellers, leading to reduced operating expenses. 2 control methods are common:

Flow meter

Because the desired flow rate is known and is constant, a flow meter installed at the discharge of each chiller, can be used to control the pump directly. Using the built-in PI controller, the drive always maintains the appropriate flow rate, even compensating for the changing resistance in the primary piping loop as chillers and their pumps are staged on and off.

Local speed determination

The operator simply decreases the output frequency until the design flow rate is achieved.

Using a drive to decrease the pump speed is very similar to trimming the pump impeller, except it does not require any labor, and the pump efficiency remains higher. The balancing contractor simply decreases the speed of the pump until the proper flow rate is achieved and leaves the speed fixed. The pump operates at this speed any time the chiller is staged on. Because the primary loop does not have control valves or other devices that can cause the system curve to change, and the variance due to staging pumps and chillers on and off is usually small, this fixed speed remains appropriate. If the flow rate needs to be increased later in the system’s life, the drive can simply increase the pump speed instead of requiring a new pump impeller.

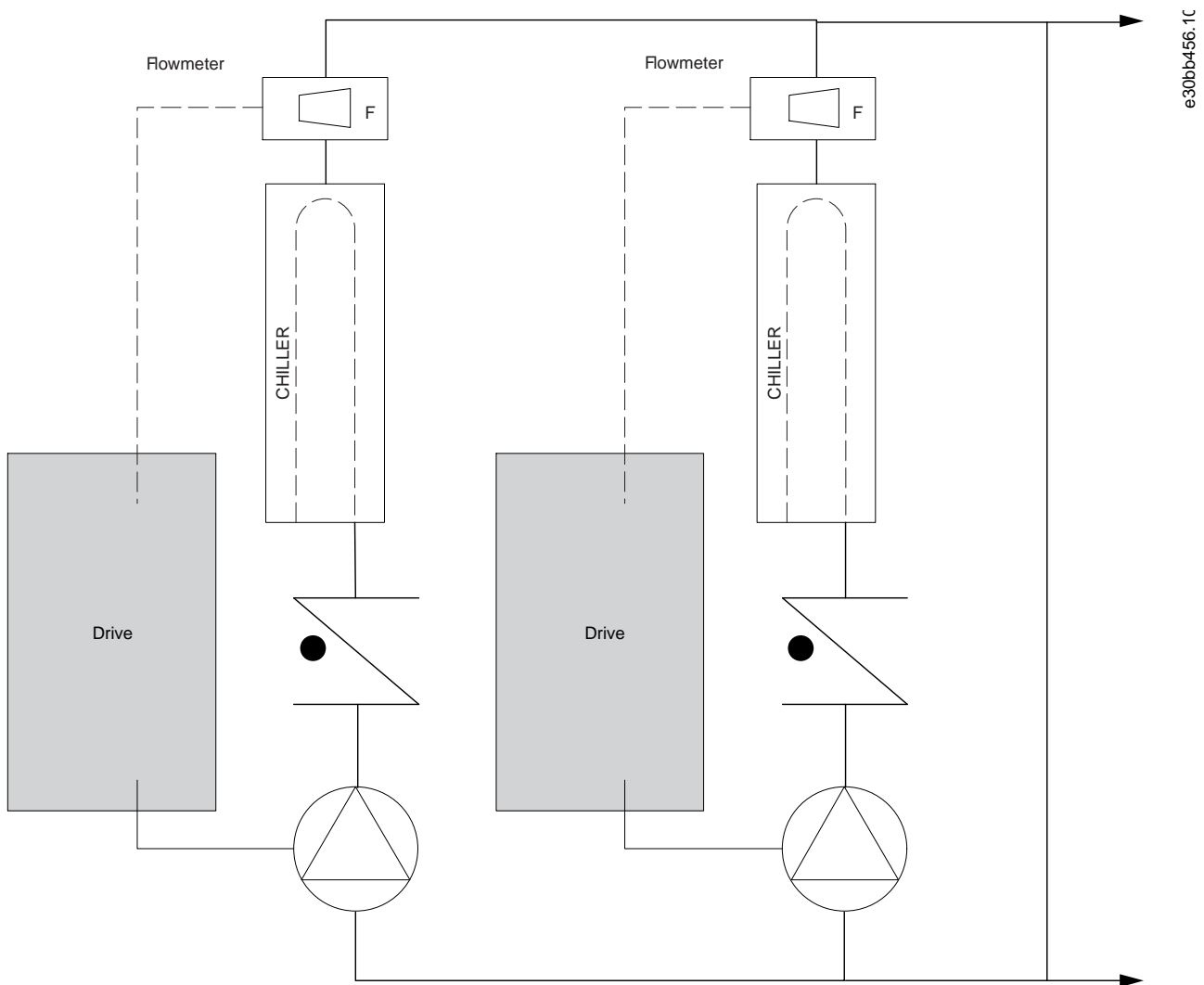

Illustration 15: Primary Pumps

3.1.2.6 Secondary Pumps

Secondary pumps in a primary/secondary chilled water pumping system distribute the chilled water to the loads from the primary production loop. The primary/secondary pumping system is used to hydraulically de-couple 1 piping loop from another. In this case, the primary pump is used to maintain a constant flow through the chillers while allowing the secondary pumps to vary in flow, increase control and save energy.

If the primary/secondary concept is not used in the design of a variable volume system when the flow rate drops far enough or too quickly, the chiller cannot shed its load properly. The chiller's low evaporator temperature safety then trips the chiller requiring a manual reset. This situation is common in large installations especially when 2 or more chillers in parallel are installed.

The VLT Solution

While the primary-secondary system with 2-way valves improves energy savings and eases system control problems, the true energy savings and control potential is realized by adding drives.

With the proper sensor location, the addition of drives allows the pumps to vary their speed to follow the system curve instead of the pump curve. This results in the elimination of wasted energy and eliminates most of the overpressurization that 2-way valves can be subjected to.

As the monitored loads are reached, the 2-way valves close down. This increases the differential pressure measured across the load and the 2-way valve. As this differential pressure starts to rise, the pump is slowed to maintain the control head also called setpoint value. This setpoint value is calculated by summing the pressure drop of the load and the 2-way valve together under design conditions.

NOTICE

When running multiple pumps in parallel, they must run at the same speed to maximize energy savings, either with individual dedicated drives or 1 drive running multiple pumps in parallel.

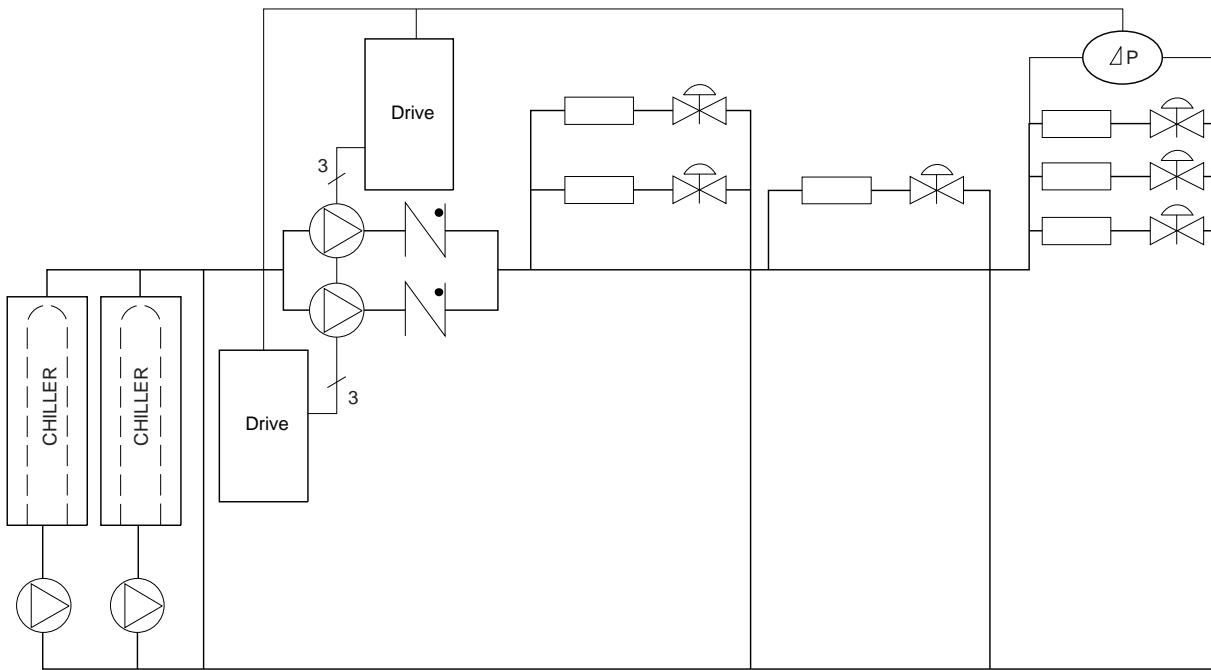

Illustration 16: Secondary Pumps

3.1.3 Check Valve Monitoring

In the pump application system, a damaged check valve is hard to detect, which therefore causes low efficiency of the whole system. VLТ® Flow Drive FC 111 has the ability to monitor the status of check valves in the system. After enabling the check valve monitoring function via setting the *parameter 22-04 Check Valve Monitor* to [1] Enabled, once a damaged check valve is detected, the drive trips *warning 159, Check Valve Failure*.

3.1.4 Dry Pump Detection

In the pump application system, the drive monitors the operation status of the system to detect whether there is water on pump's suction side. If the pump runs at maximum speed and consumes little power, then it can be assumed that there is no water on the pump's suction side. Via setting the *parameter 22-26 Dry Pump Function* to warning or alarm, once the dry pump condition is detected, the drive trips *warning/alarm 93, dry pump*.

3.1.5 End of Curve Detection

In the pump application system, the drive monitors the operation status of the system to detect whether the pressure side of pump is subject to a major leakage. If the pump runs at maximum speed for a defined time period, but the pressure is below the set point, then it can be considered to reflect the end of curve situation. Via setting the *parameter 22-50 End of Curve Function* to warning or alarm, once the end of curve condition is detected, the drive trips *warning/alarm 94, end of curve*.

3.1.6 Time-based Functions

In some application scenarios, there are requirements to control the motor running for a specific time, in a specific direction and a specific speed within a specific time interval. For example, checking the motor status in fire mode or exercising pumps, fans, and compressors.

For detailed parameter settings, refer to the *parameter group 23-** Time-based Functions* in the drive's Programming Guide.

3.2 Control Structures

3.2.1 Introduction

There are two control modes for the drive:

- Open loop.
- Closed loop.

Select [0] Open loop or [1] Closed loop in *parameter 1-00 Configuration Mode*.

3.2.2 Control Structure Open Loop

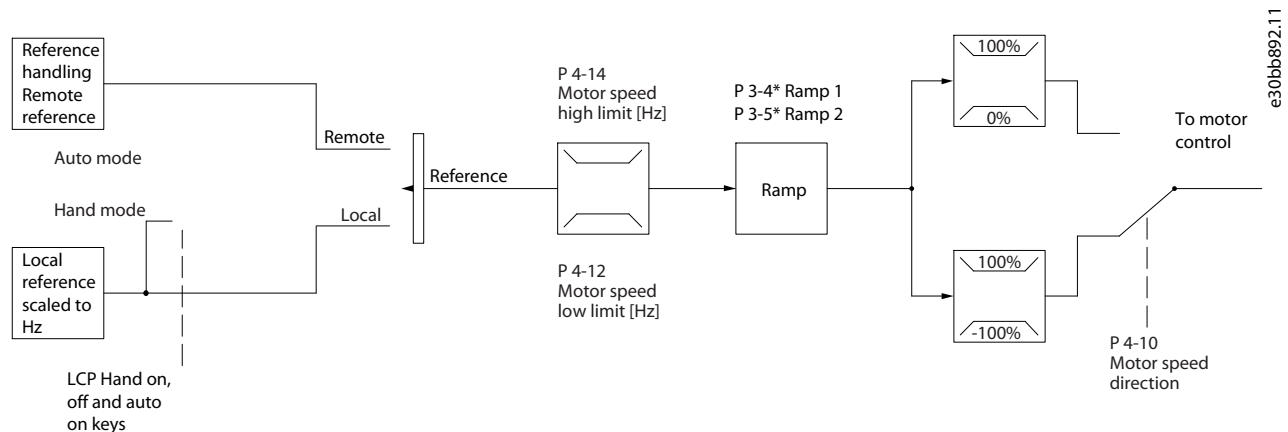

Illustration 17: Open-loop Structure

In the configuration shown in the above illustration, *parameter 1-00 Configuration Mode* is set to *[0] Open loop*. The resulting reference from the reference handling system or the local reference is received and fed through the ramp limitation and speed limitation before being sent to the motor control. The output from the motor control is then limited by the maximum frequency limit.

3.2.3 PM/EC+ Motor Control

The Danfoss EC+ concept provides the possibility for using high-efficient PM motors (permanent magnet motors) in IEC standard enclosure sizes operated by Danfoss drives.

The commissioning procedure is comparable to the existing one for asynchronous (induction) motors by utilizing the Danfoss VVC+ PM control strategy.

Customer advantages:

- Free choice of motor technology (permanent magnet or induction motor).
- Installation and operation as know on induction motors.
- Manufacturer independent when selecting system components (for example, motors).
- Best system efficiency by selecting best components.
- Possible retrofit of existing installations.
- Power range: 0.37–90 kW (0.5–121 hp) (400 V) for induction motors and 0.37–22 kW (0.5–30 hp) (400 V) for PM motors.

Current limitations for PM motors:

- Currently only supported up to 22 kW (30 hp).
- LC filters are not supported with PM motors.
- Kinetic back-up algorithm is not supported with PM motors.
- Support only complete AMA of the stator resistance R_s in the system.
- No stall detection (supported from software version 62.80).

3.2.4 Local (Hand On) and Remote (Auto On) Control

The drive can be operated manually via the local control panel (LCP) or remotely via analog/digital inputs or serial bus. If allowed in *parameter 0-40 [Hand on] Key on LCP*, *parameter 0-44 [Off/Reset] Key on LCP*, and *parameter 0-42 [Auto on] Key on LCP*, it is possible to start and stop the drive via LCP by pressing *[Hand On]* and *[Off/Reset]*. Alarms can be reset via the *[Off/Reset]* key.

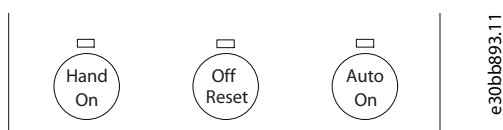

Illustration 18: LCP Keys

Local reference forces the configuration mode to open loop, independent on the setting of *parameter 1-00 Configuration Mode*.

Local reference is restored at power-down.

3.2.5 Control Structure Closed Loop

The internal controller allows the drive to become a part of the controlled system. The drive receives a feedback signal from a sensor in the system. It then compares this feedback to a setpoint reference value and determines the error, if any, between these 2 signals. It then adjusts the speed of the motor to correct this error.

For example, consider a compressor application where the speed of the compressor is to be controlled to ensure a constant suction pressure in an evaporator. The suction pressure value is supplied to the drive as the setpoint reference. A pressure sensor measures the actual suction pressure in the evaporator and supplies the data to the drive as a feedback signal. If the feedback signal is greater than the setpoint reference, the drive speeds up the compressor to reduce the pressure. In a similar way, if the suction pressure is lower than the setpoint reference, the drive automatically slows down the compressor to increase the pressure.

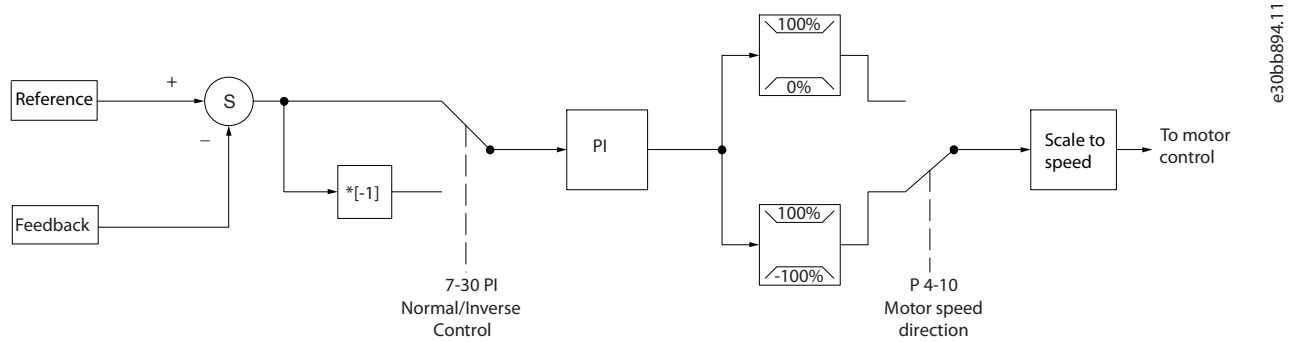

Illustration 19: Control Structure Closed Loop

While the default values for the closed-loop controller of the drive often provide satisfactory performance, the control of the system can often be optimized by adjusting parameters.

3.2.6 Feedback Conversion

In some applications, it may be useful to convert the feedback signal. One example of this is using a pressure signal to provide flow feedback. Since the square root of pressure is proportional to flow, the square root of the pressure signal yields a value proportional to the flow. See the following illustration.

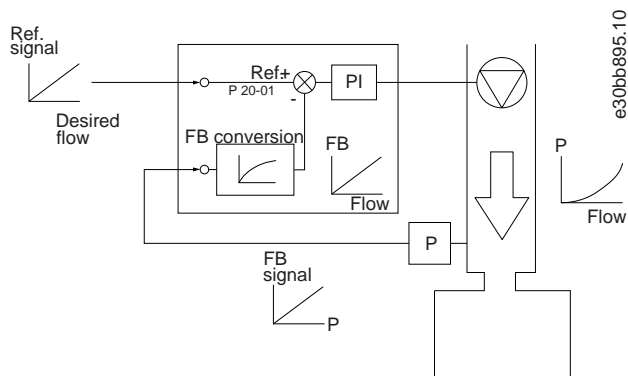
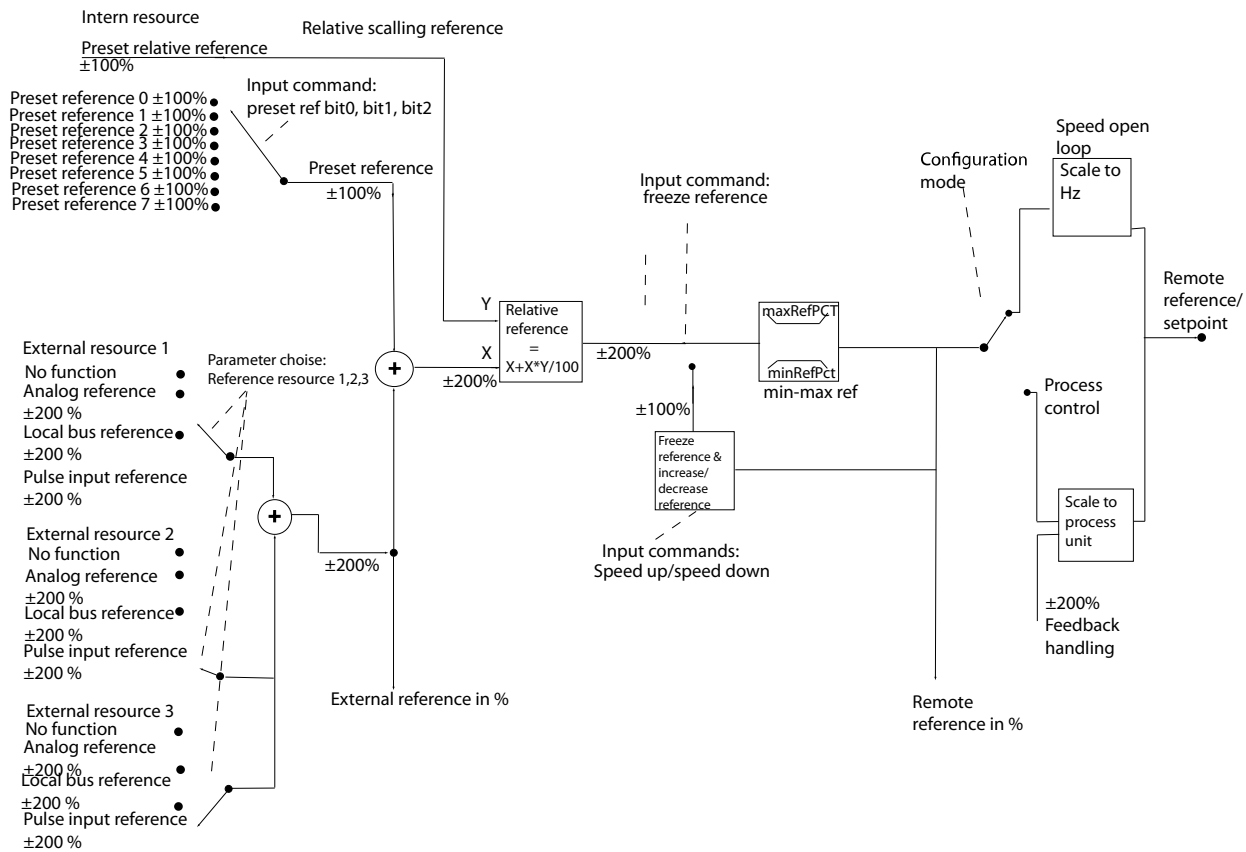

Illustration 20: Feedback Signal Conversion

3.2.7 Reference Handling

Details for open-loop and closed-loop operation.



e30be842.10

Illustration 21: Block Diagram Showing Remote Reference

The remote reference consists of:

- Preset references.
- External references (analog inputs and serial communication bus references).
- The preset relative reference.
- Feedback-controlled setpoint.

Up to 8 preset references can be programmed in the drive. The active preset reference can be selected using digital inputs or the serial communications bus. The reference can also be supplied externally, most commonly from an analog input. This external source is selected by 1 of the 3 reference source parameters (*parameter 3-15 Reference 1 Source*, *parameter 3-16 Reference 2 Source*, and *parameter 3-17 Reference 3 Source*). All reference resources and the bus reference are added to produce the total external reference. The external reference, the preset reference, or the sum of the 2 can be selected to be the active reference. Finally, this reference can be scaled using *parameter 3-14 Preset Relative Reference*.

The scaled reference is calculated as follows:

$$\text{Reference} = X + X \times \left(\frac{Y}{100} \right)$$

Where X is the external reference, the preset reference or the sum of these and Y is *parameter 3-14 Preset Relative Reference* in [%]. If Y, *parameter 3-14 Preset Relative Reference*, is set to 0%, the reference is not affected by the scaling.

3.2.8 Tuning the Drive Closed-loop

Once the drive's closed-loop controller has been set up, test the performance of the controller. Often, its performance may be acceptable using the default values of *parameter 20-93 PI Proportional Gain* and *parameter 20-94 PI Integral Time*. However, sometimes it may be helpful to optimize these parameter values to provide faster system response while still controlling speed overshoot.

3.2.9 Adjusting the Manual PI

Procedure

1. Start the motor.

2. Set *parameter 20-93 PI Proportional Gain* to 0.3 and increase it until the feedback signal begins to oscillate. If necessary, start and stop the drive or make step changes in the setpoint reference to attempt to cause oscillation.
3. Reduce the PI proportional gain until the feedback signal stabilizes.
4. Reduce the proportional gain by 40–60%.
5. Set *parameter 20-94 PI Integral Time* to 20 s and reduce it until the feedback signal begins to oscillate. If necessary, start and stop the drive or make step changes in the setpoint reference to attempt to cause oscillation.
6. Increase the PI integral time until the feedback signal stabilizes.
7. Increase the integral time by 15–50%.

3.3 Ambient Running Conditions

3.3.1 Air Humidity

The drive has been designed to meet the IEC/EN 60068-2-3 standard, EN 50178 9.4.2.2 at 50 °C (122 °F).

3.3.2 Acoustic Noise or Vibration

If the motor or the equipment driven by the motor - for example, a fan - makes noise or vibrations at certain frequencies, configure the following parameters or parameter groups to reduce or eliminate the noise or vibrations:

- *Parameter group 4-6* Speed Bypass.*
- Set *parameter 14-03 Overmodulation* to [0] Off.
- Switching pattern and switching frequency *parameter group 14-0* Inverter Switching.*
- *Parameter 1-64 Resonance Dampening.*

3.3.2.1 Acoustic Noise

The acoustic noise from the drive comes from 3 sources:

- DC-link coils.
- Integral fan.
- RFI filter choke.

Table 6: Typical Values Measured at a Distance of 1 m (3.28 ft) from the Unit

Enclosure size	Level [dBA] ⁽¹⁾
H1	43.6
H2	50.2
H3	53.8
H4	64
H5	63.7
H6	71.5
H7	67.5 (75 kW (100 hp) 71.5 dB)
H8	73.5
H13	73
H14	75

¹ The values are measured under the background of 35 dBA noise and the fan running with full speed.

3.3.2.2 Vibration and Shock

The drive has been tested according to the following standards:

- IEC/EN 60068-2-6: Vibration (sinusoidal) - 1970
- IEC/EN 60068-2-64: Vibration, broad-band random

The drive complies with the requirements that exist for units mounted on the walls and floors of production premises, and in panels bolted to walls or floors.

3.3.3 Aggressive Environments

A drive contains many mechanical and electronic components. All are to some extent vulnerable to environmental effects.

! C A U T I O N !

INSTALLATION ENVIRONMENTS

Failure to take necessary protective measures increases the risk of stoppages, potentially causing equipment damage and personnel injury.

- Do not install the drive in environments with airborne liquids, particles, or gases that may affect or damage the electronic components.

Liquids can be carried through the air and condense in the drive and may cause corrosion of components and metal parts. Steam, oil, and salt water may cause corrosion of components and metal parts. As an extra protection, coated printed circuit boards can be ordered as an option (standard on some power sizes).

Airborne particles such as dust may cause mechanical, electrical, or thermal failure in the drive. A typical indicator of excessive levels of airborne particles is dust particles around the drive fan. In dusty environments, use a cabinet for IP20/TYPE 1 equipment.

In environments with high temperatures and humidity, corrosive gases such as sulphur, nitrogen, and chlorine compounds cause chemical processes on the drive components.

Such chemical reactions rapidly affect and damage the electronic components. In such environments, mount the equipment in a cabinet with fresh air ventilation, keeping aggressive gases away from the drive. An extra protection in such areas is a coating of the printed circuit boards, which can be ordered as an option.

Before installing the drive, check the ambient air for liquids, particles, and gases. This is done by observing existing installations in this environment. Typical indicators of harmful airborne liquids are water or oil on metal parts, or corrosion of metal parts.

Excessive dust particle levels are often found on installation cabinets and existing electrical installations. One indicator of aggressive airborne gases is blackening of copper rails and cable ends on existing installations.

3.4 General Aspects of EMC

3.4.1 Overview of EMC Emissions

Drives (and other electrical devices) generate electronic or magnetic fields that may interfere with their environment. The electromagnetic compatibility (EMC) of these effects depends on the power and the harmonic characteristics of the devices.

Uncontrolled interaction between electrical devices in a system can degrade compatibility and impair reliable operation. Interference may take the form of mains harmonics distortion, electrostatic discharges, rapid voltage fluctuations, or high-frequency interference. Electrical devices generate interference along with being affected by interference from other generated sources.

Electrical interference usually occur at frequencies in the range 150 kHz to 30 MHz. Airborne interference from the drive system in the range 30 MHz to 1 GHz is generated from the inverter, the motor cable, and the motor.

Capacitive currents in the motor cable coupled with a high dU/dt from the motor voltage generate leakage currents, as shown in the following illustration.

The use of a shielded motor cable increases the leakage current (see the following illustration) because shielded cables have higher capacitance to ground than unshielded cables. If the leakage current is not filtered, it causes greater interference on the mains in the radio frequency range below approximately 5 MHz. Since the leakage current (I_1) is carried back to the unit through the shield (I_3), there is only a small electromagnetic field (I_4) from the shielded motor cable according to the following illustration.

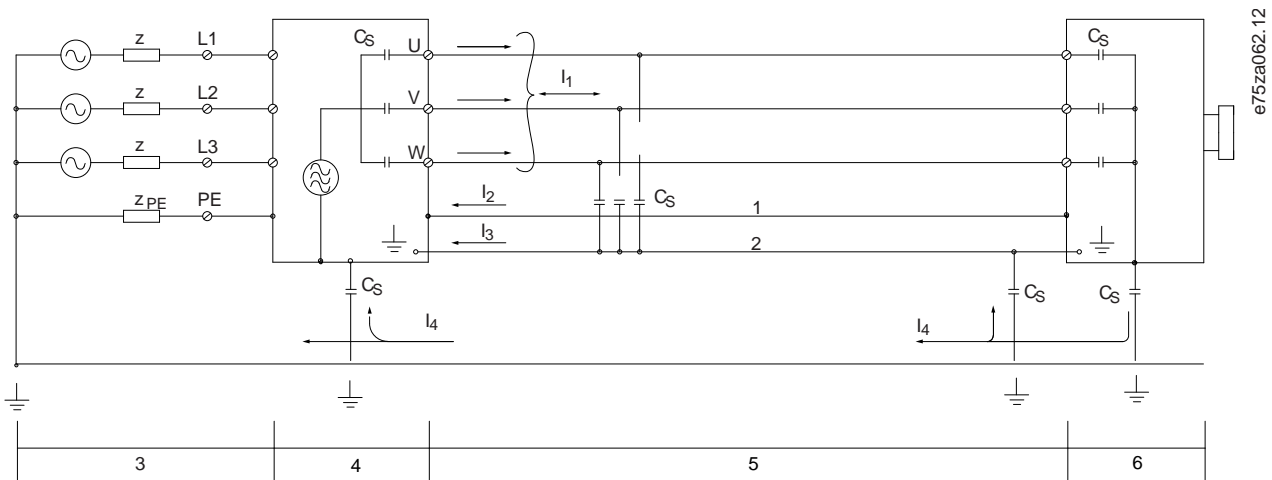

Illustration 22: Generation of Leakage Currents

1	Ground wire	4	Drive
2	Shield	5	Shielded motor cable
3	AC mains supply	6	Motor

The shield reduces the radiated interference, but increases the low-frequency interference on the mains. Connect the motor cable shield to the drive enclosure and on the motor enclosure. This is best done by using integrated shield clamps to avoid twisted shield ends (pigtailed). Pigtailed increase the shield impedance at higher frequencies, which reduces the shield effect and increases the leakage current (I_4).

If a shielded cable is used for relay, control cable, signal interface, and brake, mount the shield on the enclosure at both ends. In some situations, however, it is necessary to break the shield to avoid current loops.

If the shield is to be placed on a mounting plate for the drive, the mounting plate must be made of metal, to convey the shield currents back to the unit. Moreover, ensure good electrical contact from the mounting plate through the mounting screws to the drive chassis.

When using unshielded cables, some emission requirements are not complied with, although most immunity requirements are observed.

To reduce the interference level from the entire system (unit+installation), make motor and brake cables as short as possible. Avoid placing cables with a sensitive signal level alongside motor and brake cables. Radio interference higher than 50 MHz (airborne) is especially generated by the control electronics.

3.4.2 Emission Requirements

The EMC product standard for drives defines 4 categories (C1, C2, C3, and C4) with specified requirements for emission and immunity. The following table states the definition of the 4 categories and the equivalent classification from EN 55011.

Table 7: Correlation between IEC 61800-3 and EN 55011

EN/IEC 61800-3 Category	Definition	Equivalent emission class in EN 55011
C1	Drives installed in the first environment (home and office) with a supply voltage less than 1000 V.	Class B
C2	Drives installed in the first environment (home and office) with a supply voltage less than 1000 V, which are neither plug-in nor movable and are intended to be installed and commissioned by a professional.	Class A Group 1
C3	Drives installed in the second environment (industrial) with a supply voltage lower than 1000 V.	Class A Group 2
C4	Drives installed in the second environment with a supply voltage equal to or above 1000 V or rated current equal to or above 400 A or intended for use in complex systems.	No limit line. Make an EMC plan.

When the generic (conducted) emission standards are used, the drives are required to comply with the limits in the following table.

Table 8: Correlation between Generic Emission Standards and EN 55011

Environment	Generic emission standard	Equivalent emission class in EN 55011
First environment (home and office)	EN/IEC 61000-6-3 Emission standard for residential, commercial and light industrial environments.	Class B
Second environment (industrial environment)	EN/IEC 61000-6-4 Emission standard for industrial environments.	Class A Group 1

3.4.3 EMC Emission Test Results

The following test results have been obtained using a system with a drive, a shielded control cable, a control box with potentiometer, and a shielded motor cable.

Table 9: EMC Emission Test Results, H1–H8

RFI filter type	Conduct emission. Maximum shielded cable length [m (ft)]						Radiated emission			
	Industrial environment									
EN 55011	Class A Group 2 Industrial environment	Class A Group 1 Industrial environment	Class B Housing, trades and light industries	Class A Group 1 Industrial environment	Class B Housing, trades and light industries	Class A Group 1 Industrial environment	Class B Housing, trades and light industries	Class A Group 1 Industrial environment	Class B Housing, trades and light industries	Class B Housing, trades and light industries
EN/IEC 61800-3	Category C3 Second environment industrial	Category C2 First environment home and office	Category C1 First environment home and office	Category C2 First environment home and office	Category C1 First environment home and office	Category C2 First environment home and office	Category C1 First environment home and office	Category C2 First environment home and office	Category C1 First environment home and office	Category C1 First environment home and office
	Without external filter	With external filter	Without external filter	With external filter	Without external filter	With external filter	Without external filter	With external filter	Without external filter	With external filter
H4 RFI filter (EN55011 A1, EN/IEC61800-3 C2)										
0.37–22 kW (0.5–30 hp) 3x380–480 V IP20	–	–	25 (82)	50 (164)	–	20 (66)	Yes	Yes	–	No
H2 RFI filter (EN 55011 A2, EN/IEC 61800-3 C3)										
30–90 kW (40–125 hp) 3x380–480 V IP20	25 (82)	–	–	–	–	–	No	–	No	–
H3 RFI filter (EN55011 A1/B, EN/IEC 61800-3 C2/C1)										
30–90 kW (40–125 hp) 3x380–480 V IP20	–	–	50 (164)	–	20 (66)	–	Yes	–	No	–

Table 10: EMC Emission Test Results, H13–H14

RFI filter type	Conduct emission. Maximum shielded cable length [m (ft)]			Radiated emission		
	EN 55011	Class B Housing, trades and light industries	Class A Group 1 Industrial environment	Class A Group 2 Industrial environment	Class B Housing, trades and light industries	Class A Group 1 Industrial environment
EN/IEC 61800-3	Category C1 First environment home and office	Category C2 First environment home and office	Category C3 Second environment industrial	Category C1 First environment home and office	Category C2 First environment home and office	Category C3 First environment home and office
H2 RFI filter (EN 55011 A2, EN/IEC 61800-3 C3)						
110–315 kW (150– 450 hp) 3x380–480 V IP20	No	No	150 m (492 ft)	No	No	Yes

3.4.4 Harmonics Emission

A drive takes up a non-sinusoidal current from mains, which increases the input current I_{RMS} . A non-sinusoidal current is transformed with a Fourier analysis and split into sine-wave currents with different frequencies, that is, different harmonic currents I_n with 50 Hz basic frequency:

Table 11: Harmonic Currents

	I_1	I_5	I_7
Hz	50	250	350

The harmonics do not affect the power consumption directly, but increase the heat losses in the installation (transformer, cables). So, in plants with a high percentage of rectifier load, maintain harmonic currents at a low level to avoid overload of the transformer and high temperature in the cables.

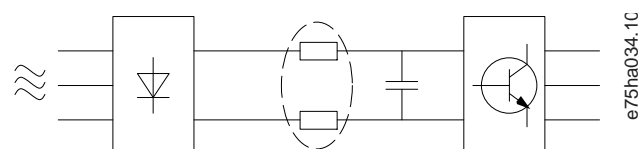

Illustration 23: DC-link Coils

N O T I C E

Some of the harmonic currents might disturb communication equipment connected to the same transformer or cause resonance with power factor correction batteries.

To ensure low harmonic currents, the drive is equipped with DC-link coils as standard. This normally reduces the input current I_{RMS} by 40%.

The voltage distortion on the mains supply voltage depends on the size of the harmonic currents multiplied by the mains impedance for the frequency in question. The total voltage distortion THD_v is calculated based on the individual voltage harmonics using this formula:

$$THD \% = \sqrt{U_5^2 + U_7^2 + \dots + U_N^2}$$

(U_N % of U)

3.4.4.1 Harmonics Emission Requirements

Equipment is connected to the public supply network.

Table 12: Connected Equipment

Options	Definition
1	IEC/EN 61000-3-2 Class A for 3-phase balanced equipment (for professional equipment only up to 1 kW (1.3 hp) total power).
2	IEC/EN 61000-3-12 Equipment 16–75 A and professional equipment as from 1 kW (1.3 hp) up to 16 A phase current.

3.4.4.2 Harmonics Test Results (Emission)

Power sizes up to 10 kW (15 hp) [200–240 V AC] comply with IEC/EN 61000-3-12, Table 4. Power sizes up to 30 kW (40 hp) [380–480 V AC] comply with IEC/EN 61000-3-2 Class A and IEC/EN 61000-3-12, Table 4.

Table 13: Harmonic Current 6.0–10 kW (8.0–15 hp), 200 V

	Individual harmonic current I_n/I_1 (%)			
	I_5	I_7	I_{11}	I_{13}
Actual 6.0–10 kW (8.0–15 hp), IP20, 200 V (typical)	32.6	16.6	8.0	6.0
Limit for $R_{sce} \geq 120$	40	25	15	10
	Harmonic current distortion factor (%)			
	THDi		PWHd	
Actual 6.0–10 kW (8.0–15 hp), 200 V (typical)	39		41.4	
Limit for $R_{sce} \geq 120$	48		46	

Table 14: Harmonic Current 6.0–22 kW (8.0–30 hp), 380–480 V

	Individual harmonic current I_n/I_1 (%)			
	I_5	I_7	I_{11}	I_{13}
Actual 6.0–22 kW (8.0–30 hp), IP20, 380–480 V (typical)	36.7	20.8	7.6	6.4
Limit for $R_{sce} \geq 120$	40	25	15	10
	Harmonic current distortion factor (%)			
	THDi		PWHd	
Actual 6.0–22 kW (8.0–30 hp), 380–480 V (typical)	44.4		40.8	
Limit for $R_{sce} \geq 120$	48		46	

Table 15: Harmonic Current 30 kW (40 hp), 380–480 V

	Individual harmonic current I_n/I_1 (%)			
	I_5	I_7	I_{11}	I_{13}
Actual 30 kW (40 hp), IP20, 380–480 V (typical)	36.7	13.8	6.9	4.2
Limit for $R_{sce} \geq 120$	40	25	15	10
	Harmonic current distortion factor (%)			
	THDi		PWHd	
Actual 30 kW (40 hp), 380–480 V (typical)	40.6		28.8	

Limit for $R_{sce} \geq 120$	48	46
------------------------------	----	----

If the short-circuit power of the supply S_{sc} is greater than or equal to:

$$S_{SC} = \sqrt{3} \times R_{SCE} \times U_{mains} \times I_{equ} = \sqrt{3} \times 120 \times 400 \times I_{equ}$$

at the interface point between the user's supply and the public system (R_{sce}).

The installer or user of the equipment is responsible for ensuring that the equipment is connected only to a supply with a short-circuit power S_{sc} greater than or equal to what is specified above. If necessary, consult with the distribution network operator. Other power sizes can be connected to the public supply network by consultation with the distribution network operator.

Compliance with various system level guidelines: The harmonic current data in Table 13 to Table 15 are given in accordance with IEC/EN 61000-3-12 with reference to the Power Drive Systems product standard. They may be used as the basis for calculation of the harmonic currents' influence on the power supply system and for the documentation of compliance with relevant regional guidelines: IEEE 519 -1992; G5/4.

If there is a need for further reduction of harmonic currents, passive or active filters in front of the drives can be installed. Consult Danfoss for further information.

3.4.5 Harmonics Emission Requirements

Equipment is connected to the public supply network.

Table 16: Connected Equipment

Options	Definition
1	IEC/EN 61000-3-2 Class A for 3-phase balanced equipment (for professional equipment only up to 1 kW (1.3 hp) total power).
2	IEC/EN 61000-3-12 Equipment 16–75 A and professional equipment as from 1 kW (1.3 hp) up to 16 A phase current.

3.4.6 Harmonics Test Results (Emission)

Power sizes up to PK75 in T4 complies with IEC/EN 61000-3-2 Class A. Power sizes from P1K1 and up to P90K in T4 complies with IEC/EN 61000-3-12, Table 4.

Table 17: Harmonic Current 0.37–22 kW (0.5–30 hp), 380-480 V

	Individual harmonic current I_n/I_1 (%)			
	I_5	I_7	I_{11}	I_{13}
Actual 0.37–22 kW (0.5–30 hp), IP20, 380-480 V (typical)	36.7	20.8	7.6	6.4
Limit for $R_{sce} \geq 120$	40	25	15	10
	Harmonic current distortion factor (%)			
	THDi		PWHD	
Actual 0.37–22 kW (0.5–30 hp), 380-480 V (typical)	44.4		40.8	
Limit for $R_{sce} \geq 120$	48		46	

Table 18: Harmonic Current 30–90 kW (40–120 hp), 380-480 V

	Individual harmonic current I_n/I_1 (%)			
	I_5	I_7	I_{11}	I_{13}
Actual 30–90 kW (40–120 hp), IP20, 380-480 V (typical)	36.7	13.8	6.9	4.2
Limit for $R_{sce} \geq 120$	40	25	15	10
Harmonic current distortion factor (%)				

	THDi	PWHD
Actual 30–90 kW (40–120 hp), 380-480 V (typical)	40.6	28.8
Limit for $R_{s_{ce}} \geq 120$	48	46

Provided that the short-circuit power of the supply S_{sc} is greater than or equal to:

$$S_{SC} = \sqrt{3} \times R_{SCE} \times U_{mains} \times I_{equ} = \sqrt{3} \times 120 \times 400 \times I_{equ}$$

at the interface point between the user's supply and the public system ($R_{s_{ce}}$).

It is the responsibility of the installer or user of the equipment to ensure, by consultation with the distribution network operator if necessary, that the equipment is connected only to a supply with a short-circuit power S_{sc} greater than or equal to specified above. Other power sizes can be connected to the public supply network by consultation with the distribution network operator.

Compliance with various system level guidelines: The harmonic current data in the tables above are given in accordance with IEC/EN 61000-3-12 with reference to the Power Drive Systems product standard. They may be used as the basis for calculation of the harmonic currents' influence on the power supply system and for the documentation of compliance with relevant regional guidelines: IEEE 519 -1992; G5/4.

3.4.7 Immunity Requirements

The immunity requirements for drives depend on the environment in which they are installed. The requirements for the industrial environment are higher than the requirements for the home and office environment. All Danfoss drives comply with the requirements for the industrial environment and therefore comply also with the lower requirements for home and office environment with a large safety margin.

3.5 Galvanic Isolation (PELV)

PELV offers protection through extra low voltage. Protection against electric shock is ensured when the electrical supply is of the PELV type and the installation is made as described in local/national regulations on PELV supplies.

All control terminals and relay terminals 01-03/04-06 comply with PELV (protective extra low voltage) (does not apply to grounded delta leg above 440 V).

Galvanic (ensured) isolation is obtained by fulfilling requirements for higher isolation and by providing the relevant creepage/clearance distances. These requirements are described in the EN 61800-5-1 standard.

The components that make up the electrical isolation, as described, also comply with the requirements for higher isolation and the relevant test as described in EN 61800-5-1. The PELV galvanic isolation can be shown in the following illustrations.

To maintain PELV, all connections made to the control terminals must be PELV, for example, thermistors must be reinforced/double insulated.

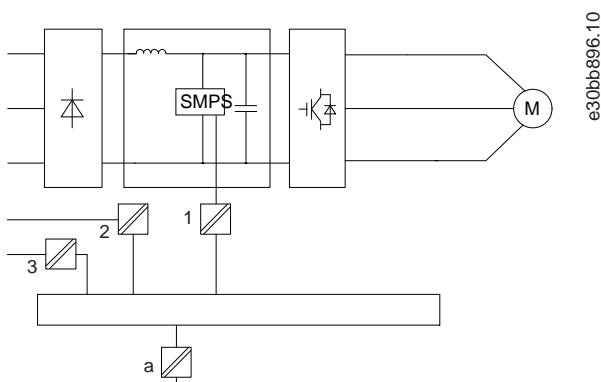

Illustration 24: Galvanic Isolation 0.37–22 kW (0.5–30 hp)

1	Supply (SMPS)	3	Custom relays
2	Optocouplers, communication between AOC and BOC	a	Control card terminals

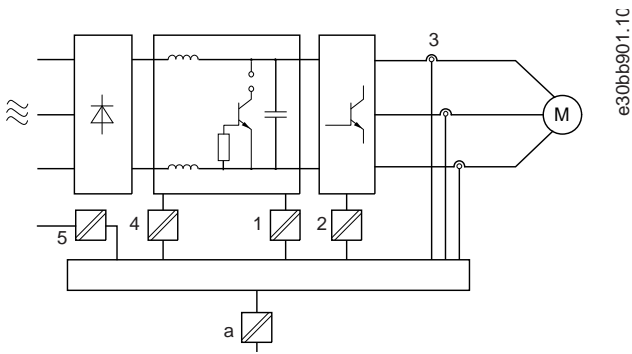

Illustration 25: Galvanic Isolation 30–90 kW (40–120 hp)

1	Supply (SMPS) including signal isolation of UDC, indicating the intermediate current voltage	4	Internal soft-charge, RFI, and temperature measurement circuits
2	Gate drive that runs the IGBTs (trigger transformers/optocouplers)	5	Custom relays
3	Current transducers	a	Control card terminals

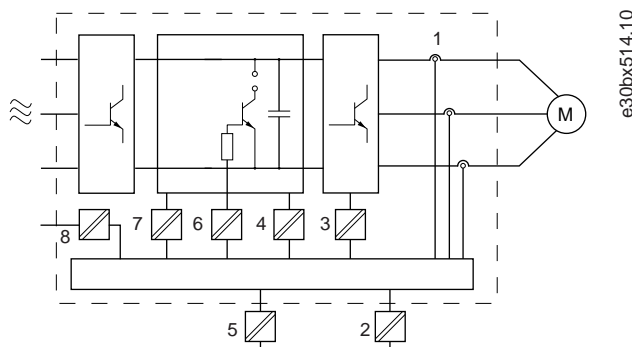

Illustration 26: Galvanic Isolation 110–315 kW (150–450 hp)

1	Current transducers	5	Galvanic isolation for the 24 V back-up option
2	Galvanic isolation for the RS485 standard bus interface	6	Opto-coupler, brake module (optional)
3	Gate drive for the IGBTs	7	Internal inrush, RFI, and temperature measurement circuits
4	Supply (SMPS) including signal isolation of V DC, indicating the intermediate current voltage	8	Customer relays

The functional galvanic isolation (see [Illustration 24](#)) is for the RS485 standard bus interface.

⚠ CAUTION ⚠

INSTALLATION AT HIGH ALTITUDE

At altitudes above 2000 m (6500 ft), contact Danfoss regarding PELV.

3.6 Ground Leakage Current

Follow national and local codes regarding protective earthing of equipment where leakage current exceeds 3.5 mA. Drive technology implies high frequency switching at high power. This generates a leakage current in the ground connection. The ground leakage current is made up of several contributions and depends on various system configurations, including:

- RFI filtering.
- Motor cable length.
- Motor cable shielding.
- Drive power.

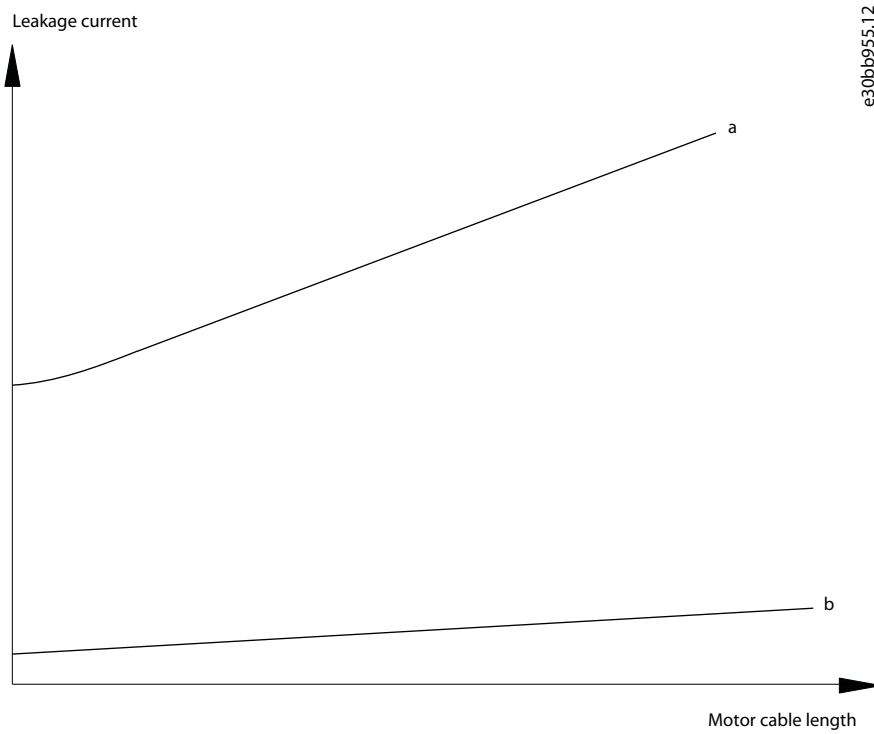

Illustration 27: Influence of the Cable Length and Power Size on Leakage Current, Power Size a > Power Size B

The leakage current also depends on the line distortion.

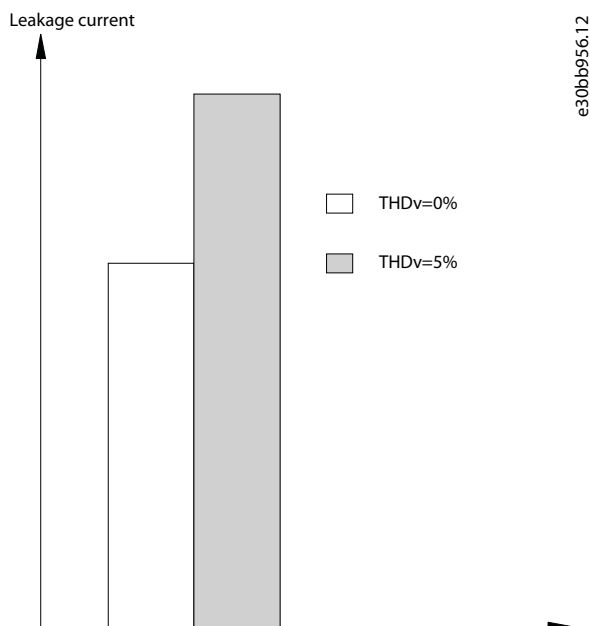

Illustration 28: Influence of Line Distortion on Leakage Current

If the leakage current exceeds 3.5 mA, compliance with EN/IEC 61800-5-1 (power drive system product standard) requires special care.

Reinforce grounding with the following protective earth connection requirements:

- Ground wire (terminal 95) of at least 10 mm² (8 AWG) cross-section.
- 2 separate ground wires both complying with the dimensioning rules.

See EN/IEC 61800-5-1 and IEC EN 62477-1 for further information.

⚠ WARNING ⚠

DISCHARGE TIME

Touching the electrical parts, even after the equipment has been disconnected from mains, could be fatal.

- Make sure that other voltage inputs have been disconnected, such as load sharing (linkage of DC-link), and the motor connection for kinetic back-up.
- Before touching any electrical parts, wait at least the amount of time indicated in the safety chapter. Shorter time is allowed only if indicated on the nameplate for the specific unit.

⚠ WARNING ⚠

LEAKAGE CURRENT HAZARD

Leakage currents exceed 3.5 mA. Failure to ground the drive properly can result in death or serious injury.

- Ensure the correct grounding of the equipment by a certified electrical installer.

3.6.1 Using a Residual Current Device (RCD)

Where residual current devices (RCDs), also known as earth leakage circuit breakers (ELCBs), are used, comply with the following:

- Use RCDs of type B only, which are capable of detecting AC and DC currents.
- Use RCDs with an inrush delay to prevent faults caused by transient ground currents.
- Dimension RCDs according to the system configuration and environmental considerations.

The leakage current includes several frequencies originating from both the mains frequency and the switching frequency. Whether the switching frequency is detected depends on the type of RCD used.

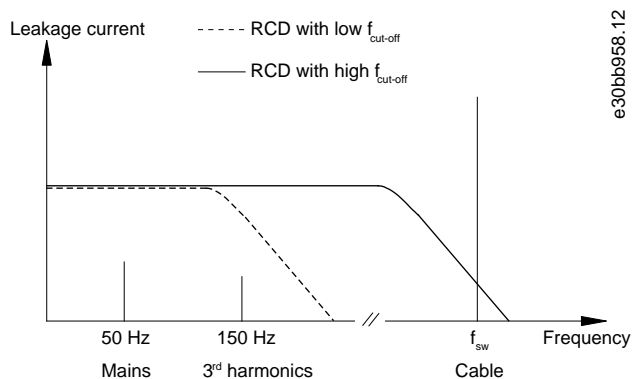

Illustration 29: Mains Contributions to Leakage Current

The amount of leakage current detected by the RCD depends on the cut-off frequency of the RCD.

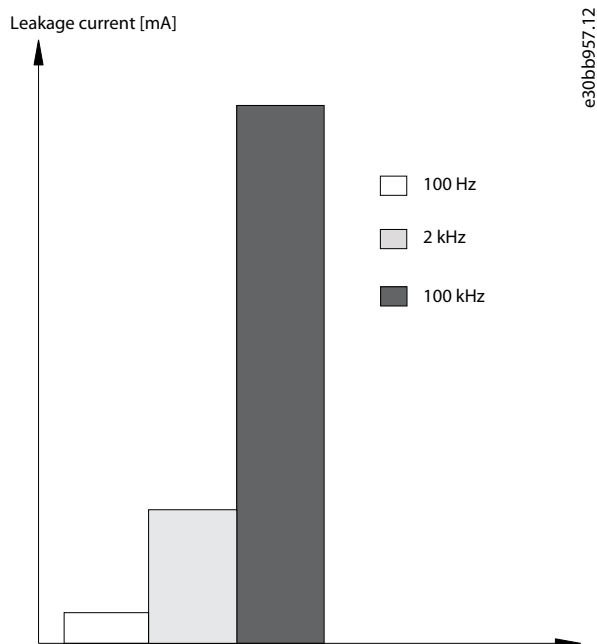

Illustration 30: Influence of Cut-off Frequency of the RCD on what is Responded to/Measured

For more details, refer to the RCD Application Note.

⚠ WARNING ⚠

RESIDUAL CURRENT DEVICE PROTECTION

This product can cause a DC current in the protective conductor. Where a residual current device (RCD) is used for protection in case of direct or indirect contact, only an RCD of Type B is allowed on the supply side of this product. Otherwise, apply another protective measure, such as separation from the environment by double or reinforced insulation, or isolation from the supply system by a transformer. See also application note Protection against Electrical Hazards.

- Protective grounding of the drive and the use of RCDs must always follow national and local regulations.

3.7 Extreme Running Conditions

3.7.1 Introduction

Short circuit (motor phase-phase)

Current measurement in each of the 3 motor phases or in the DC-link, protects the drive against short circuits. A short circuit between 2 output phases causes an overcurrent in the inverter. The inverter is turned off individually when the short circuit current exceeds the allowed value (*alarm 16, Trip Lock*).

For information about protecting the drive against a short circuit at the load sharing and brake outputs, see *chapter Fuses and Circuit Breakers*.

Switching on the output

Switching on the output between the motor and the drive is allowed. The drive is not damaged in any way by switching on the output. However, fault messages may appear.

Motor-generated overvoltage

The voltage in the DC link is increased when the motor acts as a generator. This occurs in following cases:

- The load drives the motor (at constant output frequency from the drive), that is the load generates energy.
- During deceleration (ramp-down) if the inertia moment is high, the friction is low, and the rampdown time is too short for the energy to be dissipated as a loss in the drive, the motor, and the installation.
- Incorrect slip compensation setting (*parameter 1-62 Slip Compensation*) may cause higher DC-link voltage.

The control unit may attempt to correct the ramp if *parameter 2-17 Over-voltage Control* is enabled. The drive turns off to protect the transistors and the DC-link capacitors when a certain voltage level is reached.

Mains drop-out

During a mains dropout, the drive keeps running until the DC-link voltage drops below the minimum stop level, which is typically 15% below the drive's lowest rated supply voltage. The mains voltage before the drop-out and the motor load determines how long it takes for the drive to coast.

3.7.2 Motor Thermal Protection (ETR)

Danfoss uses ETR to protect the motor from being overheated. It is an electronic feature that simulates a bimetal relay based on internal measurements. The characteristic is shown in the following illustration.

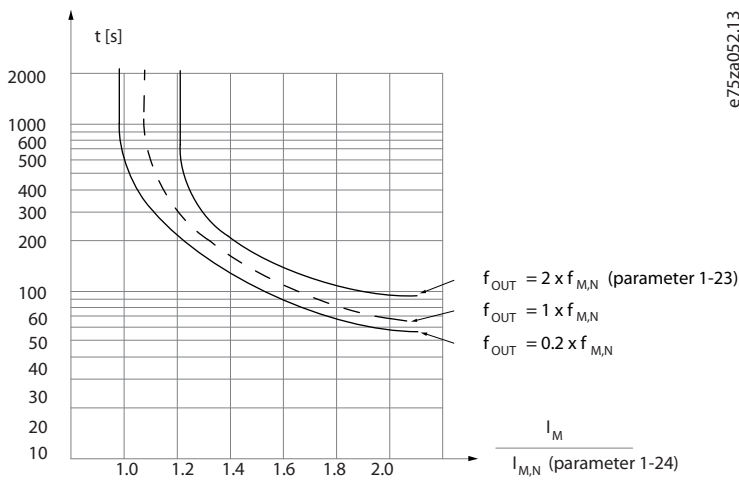

Illustration 31: Motor Thermal Protection Characteristic

The X-axis shows the ratio between I_{motor} and I_{motor} nominal. The Y-axis shows the time in seconds before the ETR cuts off and trips the drive. The curves show the characteristic nominal speed at twice the nominal speed and at 0.2x the nominal speed. It is clear that at lower speed the ETR cuts off at lower heat due to less cooling of the motor. In that way, the motor is protected from being overheated even at low speed. The ETR feature calculates the motor temperature based on actual current and speed.

3.7.3 Thermistor Inputs

The thermistor cutout value is $>3 \text{ k}\Omega$.

Integrate a thermistor (PTC sensor) in the motor for winding protection.

Motor protection can be implemented using a range of techniques:

- PTC sensor in motor windings.
- Mechanical thermal switch (Klixon type).
- Electronic thermal relay (ETR).

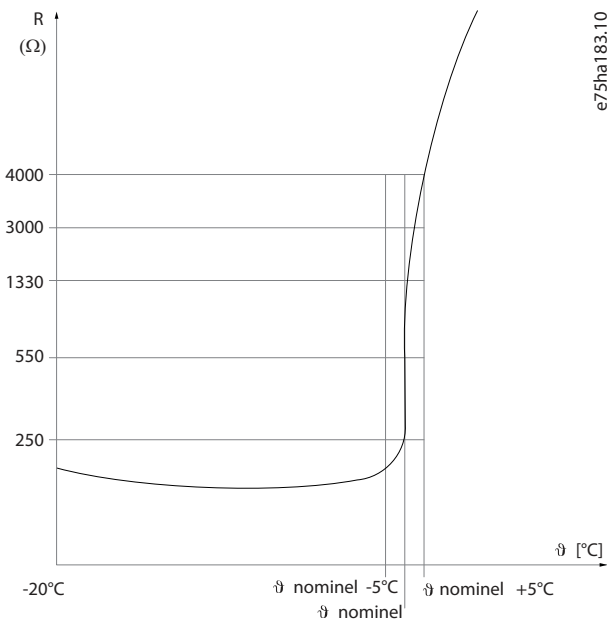

e75ha183.10

Illustration 32: Trip due to High Motor Temperature

3.7.3.1 Example with Digital Input and 10 V Power Supply

The drive trips when the motor temperature is too high.

Parameter set-up:

- Set parameter 1-90 Motor Thermal Protection to [2] Thermistor Trip.
- Set parameter 1-93 Thermistor Source to [6] Digital Input 29.

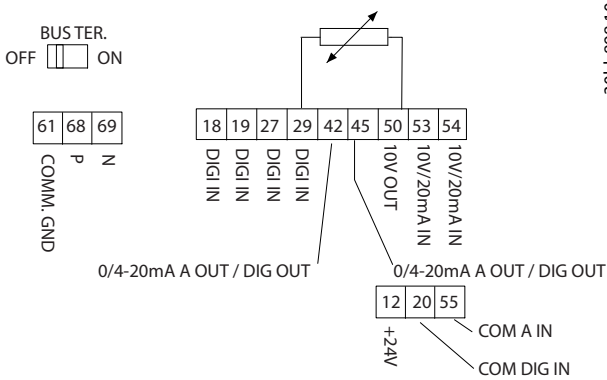

e30bb898.10

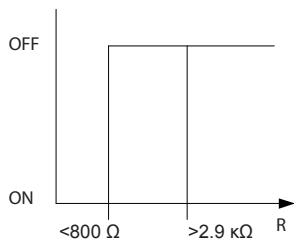

Illustration 33: Digital Input/10 V Power Supply

3.7.3.2 Example with Analog Input and 10 V Power Supply

The drive trips when the motor temperature is too high.

Parameter set-up:

- Set parameter 1-90 Motor Thermal Protection to [2] Thermistor Trip.
- Set parameter 1-93 Thermistor Source to [1] Analog Input 53.

NOTICE

Do not set Analog Input 54 as reference source.

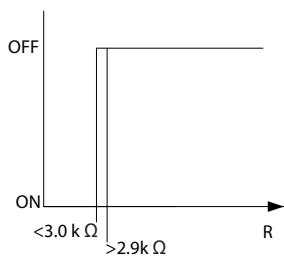
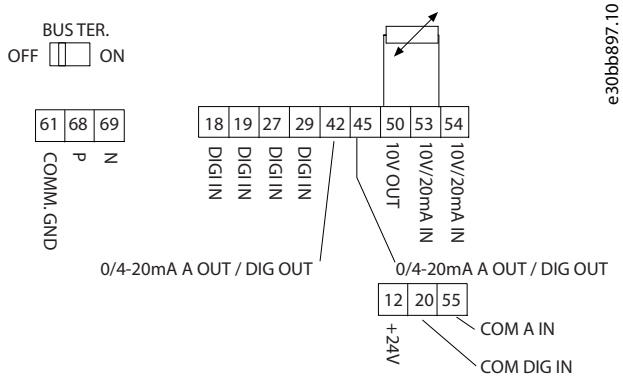

Illustration 34: Analog Input/10 V Power Supply

Table 19: Supply Voltage

Input	Supply voltage [V]	Threshold cutout values [Ω]
Digital	10	<800 \Rightarrow 2.9 k
Analog	10	<800 \Rightarrow 2.9 k

NOTICE

Make sure that the selected supply voltage follows the specification of the used thermistor element.

ETR is activated in parameter 1-90 Motor Thermal Protection.

4 Selection and Ordering

4.1 Type Code

A type code defines a specific configuration of the drive. Use the following illustration to create a type code string for the desired configuration.

1	2	3	4	5	6	7	8	9	10	11	12	13	14	15	16	17	18	19	20	21	22	23	24	25	26	27	28	29	30	31	32	33	34	35	36	37	38	39
F	C	-	1	1	1	P				T					H	X			X	X	X	S	X	X	X	X	A	X	B	X	C	X	X	X	X	D	X	

e30bu797.10

Illustration 35: Type Code

Table 20: Type Code Description

Description	Position	Possible choice
Product group & FC series	1–6	FC 111
Power rating	7–10	0.37–315 kW (0.5–450 hp) (PK37-P315)
Number of phases	11	3 phases (T)
Mains voltage	11–12	T4: 380-480 V AC
Enclosure	13–15	E20: IP20/chassis P20: IP20/chassis with back plate
RFI filter	16–17	H1: RFI filter class A1/B H2: RFI filter class A2 H3: RFI filter class A1/B (reduced cable length) H4: RFI filter class A1
Brake	18	X: No brake chopper included
Display	19	A: Alpha numeric local control panel X: No local control panel
Coating PCB	20	X: No coated PCB C: Coated PCB
Mains option	21	X: No mains option
Adaptation	22	X: No adaptation
Adaptation	23	X: No adaptation
Software release	24–27	SXXXX: Latest release - standard software
Software language	28	X: Standard
A options	29–30	AX: No A options
B options	31–32	BX: No B options
C0 options MCO	33–34	CX: No C options
C1 options	35	X: No C1 options
C option software	36–37	XX: No options

D options	38–39	DX: No D0 options
-----------	-------	-------------------

4.2 Options and Accessories

4.2.1 Local Control Panel (LCP)

Table 21: Ordering Number of LCP

Ordering number	Description
132B0200	LCP 31
132B9221	LCP 32

Table 22: Technical Data of LCP

Enclosure	Front-mounted
Maximum cable length to unit	3 m (10 ft)
Communication standard	RS485

4.2.2 IP21 Enclosure Kit

IP21 is an optional enclosure element available for IP20 units. If the enclosure kit is used, an IP20 unit is upgraded to comply with enclosure IP21.

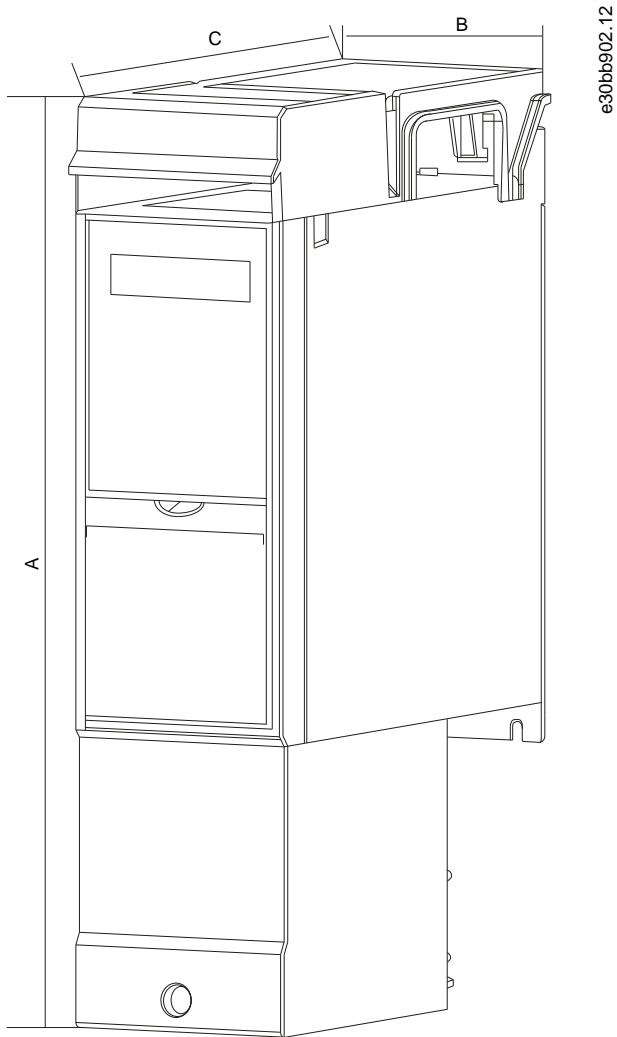

Illustration 36: H1-H5

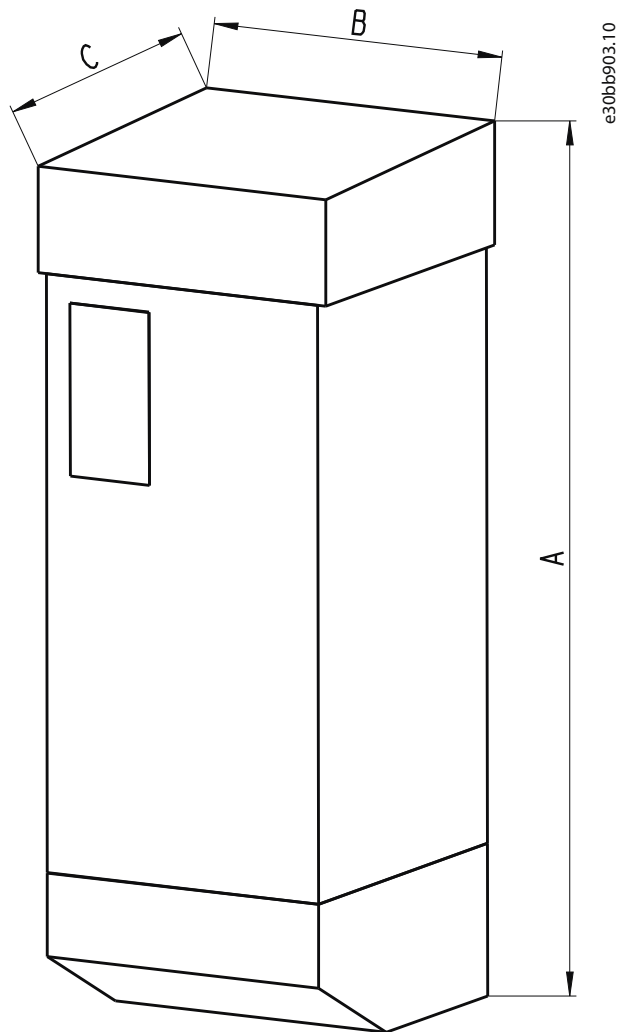

Illustration 37: Dimensions

Table 23: Enclosure Kit Specifications

Frame	IP class	3x380-480 V [kW (hp)]	Height [mm (in)] A	Width [mm (in)] B	Depth [mm (in)] C	IP21 kit ordering number
H1	IP20	0.37–1.5 (0.5–2.0)	293 (11.5)	81 (3.2)	173 (6.8)	132B0212
H2	IP20	2.2–4.0 (3.0–5.4)	322 (12.7)	96 (3.8)	195 (7.7)	132B0213
H3	IP20	5.5–7.5 (7.4–10)	346 (13.6)	106 (4.2)	210 (8.3)	132B0214
H4	IP20	11–15 (15–20)	374 (14.7)	141 (5.6)	245 (9.6)	132B0215
H5	IP20	18.5–22 (25–30)	418 (16.5)	161 (6.3)	260 (10.2)	132B0216
H6	IP20	30–45 (40–60)	663 (26.1)	260 (10.2)	242 (9.5)	132B0217
H7	IP20	55–75 (74–100)	807 (31.8)	329 (13.0)	335 (13.2)	132B0218
H8	IP20	90 (120)	943 (37.1)	390 (15.3)	335 (13.2)	132B0219

4.2.3 Decoupling Plate

Use the decoupling plate for EMC-correct installation. The following illustration shows the decoupling plate on an H3 enclosure.

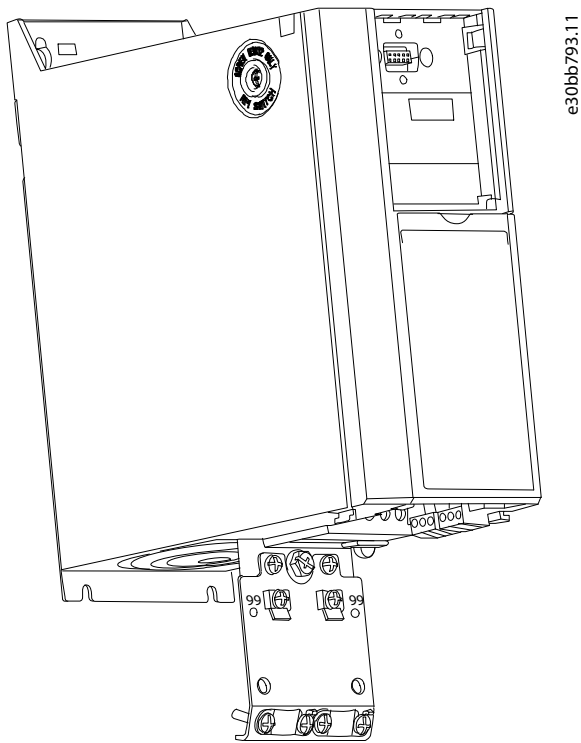

Illustration 38: Decoupling Plate

Table 24: Decoupling Plate Specifications

Frame	IP class	3x380–480 V	Decoupling plate ordering numbers
H1	IP20	0.37–1.5 (0.5–2.0)	132B0202
H2	IP20	2.2–4.0 (3.0–5.4)	132B0202
H3	IP20	5.5–7.5 (7.5–10)	132B0204
H4	IP20	11–15 (15–20)	132B0205
H5	IP20	18.5–22 (25–30)	132B0205
H6	IP20	30 (40)	132B0207
H6	IP20	37–45 (50–60)	132B0242
H7	IP20	55 (75)	132B0208
H7	IP20	75 (100)	132B0243
H8	IP20	90 (125)	132B0209

4.3 Ordering Numbers

4.3.1 Options and Accessories

Table 25: Options and Accessories

Enclosure size Mains voltage	H1 [kW (hp)]	H2 [kW (hp)]	H3 [kW (hp)]	H4 [kW (hp)]	H5 [kW (hp)]	H6 [kW (hp)]	H7 [kW (hp)]	H8 [kW (hp)]

T4 (380–480 V AC)	0.37–1.5 (0.5–2.0)	2.2–4.0 (3.0–5.4)	5.5–7.5 (7.5–10)	11–15 (15–20)	18.5–22 (25–30)	30 (40)	37–45 (50–60)	55 (75)	75 (100)	90 (125)
Description										
LCP ⁽¹⁾	132B0200									
LCP panel mounting kit including 3 m (9.8 ft) cable	132B0201									
Decoupling plate	132B0202	132B0202	132B0204	132B0205	132B0205	132B0207	132B0242	132B0208	132B0243	132B0209
IP21 option	132B0212	132B0213	132B0214	132B0215	132B0216	132B0217		132B0218		132B0219

¹ For IP20 units, LCP is ordered separately.

4.3.2 Harmonic Filters

Table 26: AHF Filters (5% Current Distortion)

3x380–480 V 50 Hz					
Power [kW (hp)]	Drive input current continuous [A]	Default switching frequency [kHz]	THDi level [%]	Order number filter IP00	Code number filter IP20
22 (30)	41.5	4	4	130B1397	130B1239
30 (40)	57	4	3	130B1398	130B1240
37 (50)	70	4	3	130B1442	130B1247
45 (60)	84	3	3	130B1442	130B1247
55 (74)	103	3	5	130B1444	130B1249
75 (100)	140	3	4	130B1445	130B1250
90 (120)	176	3	4	130B1445	130B1250

Table 27: AHF Filters (10% Current Distortion)

3x380–480 V 50 Hz					
Power [kW (hp)]	Drive input current continuous [A]	Default switching frequency [kHz]	THDi level [%]	Order number filter IP00	Code number filter IP20
22 (30)	41.5	4	6	130B1274	130B1111
30 (40)	57	4	6	130B1275	130B1176
37 (50)	70	4	9	130B1291	130B1201

45 (60)	84	3	9	130B1291	130B1201
55 (74)	103	3	9	130B1292	130B1204
75 (100)	140	3	8	130B1294	130B1213
90 (120)	176	3	8	130B1294	130B1213

Table 28: AHF Filters (5% Current Distortion)

3x440–480 V 60 Hz					
Power [kW (hp)]	Drive input current Continuous [A]	Default switching frequency [kHz]	THDi level [%]	Order number filter IP00	Code number filter IP20
22 (30)	34.6	4	3	130B1792	130B1757
30 (40)	49	4	3	130B1793	130B1758
37 (50)	61	4	3	130B1794	130B1759
45 (60)	73	3	4	130B1795	130B1760
55 (74)	89	3	4	130B1796	130B1761
75 (100)	121	3	5	130B1797	130B1762
90 (120)	143	3	5	130B1798	130B1763

Table 29: AHF Filters (10% Current Distortion)

3x440–480 V 60 Hz					
Power [kW (hp)]	Drive input current continuous [A]	Default switching frequency [kHz]	THDi level [%]	Order number filter IP00	Code number filter IP20
22 (30)	34.6	4	6	130B1775	130B1487
30 (40)	49	4	8	130B1776	130B1488
37 (50)	61	4	7	130B1777	130B1491
45 (60)	73	3	9	130B1778	130B1492
55 (74)	89	3	8	130B1779	130B1493
75 (100)	121	3	9	130B1780	130B1494
90 (120)	143	3	10	130B1781	130B1495

4.3.3 External RFI Filter

With external filters listed in the following table, the maximum shielded cable length of 50 m (164 ft) according to EN/IEC 61800-3 C2 (EN 55011 A1), or 20 m (65.6 ft) according to EN/IEC 61800-3 C1 (EN 55011 B) can be achieved.

Table 30: RFI Filters - Details

Power [kW (hp)] Size 380–480 V	Type												L1	Torque [Nm (in-lb)]	Weight [kg (lb)]	Ordering Number	
		A	B	C	D	E	F	G	H	I	J	K					

0.37–2.2 (0.5–3.0)	FN3258-7-45	190	40	70	160	180	20	4.5	1	10.6	M5	20	31	0.7–0.8 (6.2–7.1)	0.5 (1.1)	132B0244
3.0–7.5 (4.0–10)	FN3258-16-45	250	45	70	220	235	25	4.5	1	10.6	M5	22.5	31	0.7–0.8 (6.2–7.1)	0.8 (1.8)	132B0245
11–15 (15–20)	FN3258-30-47	270	50	85	240	255	30	5.4	1	10.6	M5	25	40	1.9–2.2 (16.8–19.5)	1.2 (2.6)	132B0246
18.5–22 (25–30)	FN3258-42-47	310	50	85	280	295	30	5.4	1	10.6	M5	25	40	1.9–2.2 (16.8–19.5)	1.4 (3.1)	132B0247

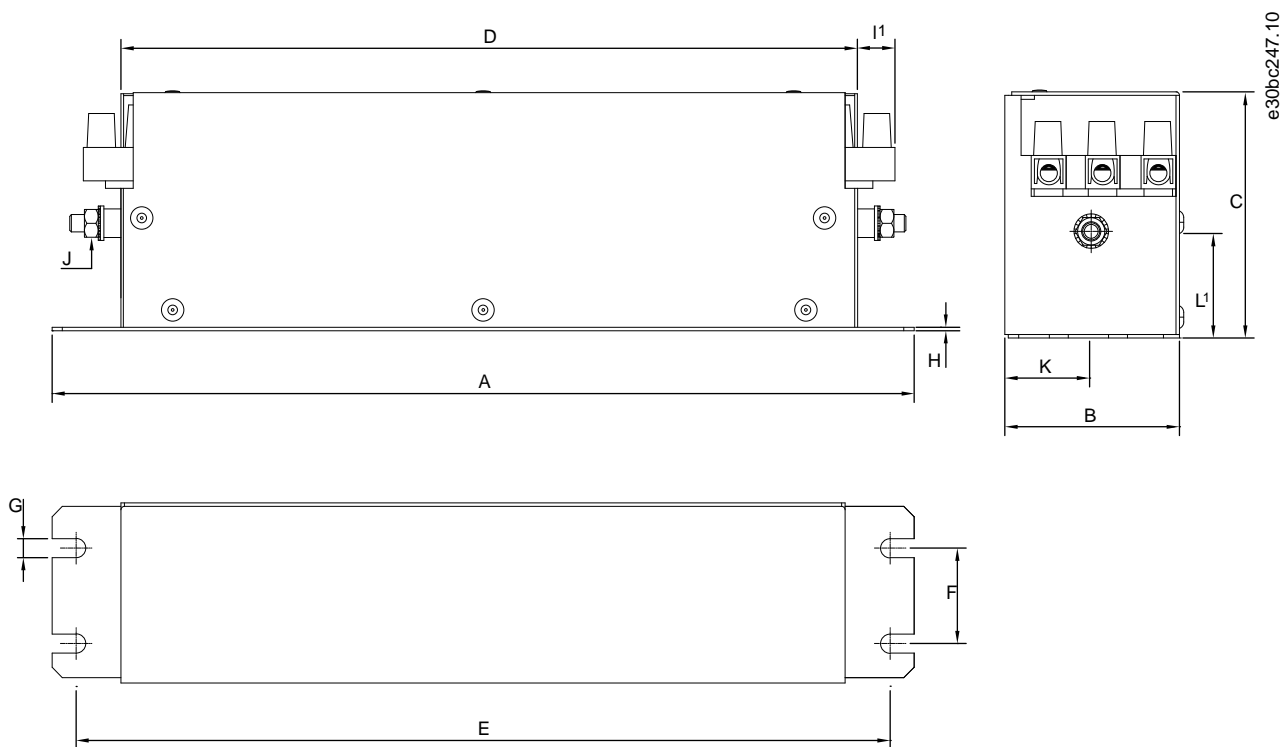

Illustration 39: RFI Filter - Dimensions

5 Mechanical Installation Considerations

5.1 Power Ratings, Weights, and Dimensions

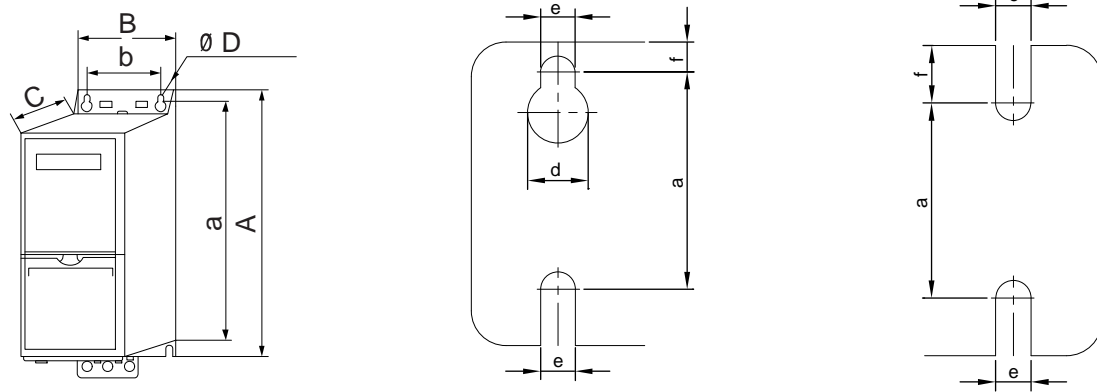

Illustration 40: Dimensions, Enclosure Sizes H1–H8

Table 31: Power Ratings, Weights, and Dimensions, Enclosure Sizes H1–H4

Enclosure Size		H1	H2	H3	H4
IP class		IP20	IP20	IP20	IP20
Power [kW (hp)]	3x380–480 V	0.37–1.5 (0.5–2.0)	2.2–4.0 (3.0–5.0)	5.5–7.5 (7.5–10)	11–15 (15–20)
Height [mm (in)]	A	195 (7.7)	227 (8.9)	255 (10.0)	296 (11.7)
	A ⁽¹⁾	273 (10.7)	303 (11.9)	329 (13.0)	359 (14.1)
	a	183 (7.2)	212 (8.3)	240 (9.4)	275 (10.8)
Width [mm (in)]	B	75 (3.0)	90 (3.5)	100 (3.9)	135 (5.3)
	b	56 (2.2)	65 (2.6)	74 (2.9)	105 (4.1)
Depth [mm (in)]	C	168 (6.6)	190 (7.5)	206 (8.1)	241 (9.5)
Mounting hole [mm (in)]	d	9 (0.35)	11 (0.43)	11 (0.43)	12.6 (0.50)
	e	4.5 (0.18)	5.5 (0.22)	5.5 (0.22)	7 (0.28)
	f	5.3 (0.21)	7.4 (0.29)	8.1 (0.32)	8.4 (0.33)
Maximum weight kg (lb)		2.1 (4.6)	3.4 (7.5)	4.5 (9.9)	7.9 (17.4)

¹ Including decoupling plate.

Table 32: Power Ratings, Weights, and Dimensions H6–H8

Enclosure Size		H5	H6	H7	H8
IP class		IP20	IP20	IP20	IP20
Power [kW (hp)]	3x380–480 V	18.5–22 (25–30)	30–45 (40–60)	55–75 (70–100)	90 (125)
Height [mm (in)]	A	334 (13.1)	518 (20.4)	550 (21.7)	660 (26)
	A ⁽¹⁾	402 (15.8)	595 (23.4)/635 (25), 45 kW	630 (24.8)/690 (27.2), 75 kW	800 (31.5)

Design Guide

Enclosure Size		H5	H6	H7	H8
	a	314 (12.4)	495 (19.5)	521 (20.5)	631 (24.8)
Width [mm (in)]	B	150 (5.9)	239 (9.4)	313 (12.3)	375 (14.8)
	b	120 (4.7)	200 (7.9)	270 (10.6)	330 (13)
Depth [mm (in)]	C	255 (10)	242 (9.5)	335 (13.2)	335 (13.2)
Mounting hole [mm (in)]	d	12.6 (0.50)	–	–	–
	e	7 (0.28)	8.5 (0.33)	8.5 (0.33)	8.5 (0.33)
	f	8.5 (0.33)	15 (0.6)	17 (0.67)	17 (0.67)
Maximum weight kg (lb)		9.5 (20.9)	24.5 (54)	36 (79)	51 (112)

¹ Including decoupling plate.

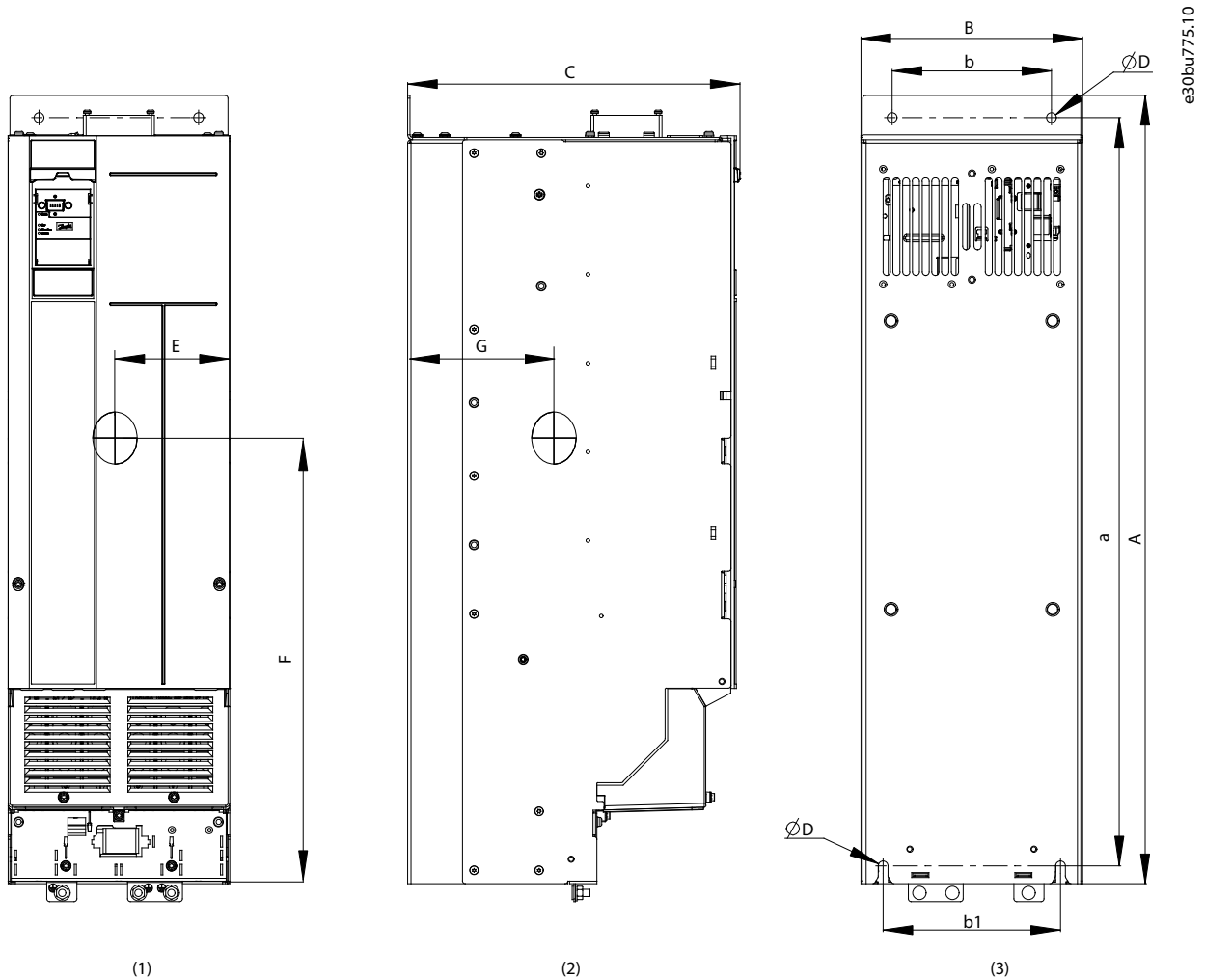

Illustration 41: Dimensions, Enclosure Sizes H13–H14

1	Front view	3	Back view
2	Side view		

Table 33: Power Ratings, Weights, and Dimensions H13–H14

Enclosure Size		H13	H14
IP class		IP20	IP20
Power [kW (hp)]	3x380–480 V	110–160 (150–250)	200–315 (300–450)
Height [mm (in)]	A	889 (35.0)	1096 (43.1)
	A ⁽¹⁾	909 (35.8)	1122 (44.2)
	a	844 (33.2)	1051 (41.4)
Width [mm (in)]	B	250 (9.8)	350 (13.8)
	b	180 (7.1)	280 (11.0)
	b1	200 (7.9)	271 (10.7)
Depth [mm (in)]	C	375 (14.8)	375 (14.8)
Mounting hole [mm (in)]	D	11 (0.4)	11 (0.4)
Center of gravity [mm (in)]	E	128 (5.0)	176 (6.9)
	F	495 (19.5)	611 (24.1)
	G	148 (5.8)	148 (5.8)
Maximum weight kg (lb)		98 (216)	164 (362)

¹ Including decoupling plate.

The dimensions are only for the physical units.

5.2 Mechanical Installation H1-H8

5.2.1 Side-by-side Installation

The drive can be mounted side by side but requires the clearance above and below for cooling.

Table 34: Clearance Required for Cooling

		Power [kW (hp)]	Clearance above/below [mm (in)]
Size	IP class	3x380–480 V	
H1	IP20	0.37–1.5 (0.5–2.0)	100 (4)
H2	IP20	2.2–4.0 (3.0–5.4)	100 (4)
H3	IP20	5.5–7.5 (7.5–10)	100 (4)
H4	IP20	11–15 (15–20)	100 (4)
H5	IP20	18.5–22 (25–30)	100 (4)
H6	IP20	30–45 (40–60)	200 (7.9)
H7	IP20	55–75 (70–100)	200 (7.9)
H8	IP20	90 (125)	225 (8.9)

N O T I C E

With IP21 option kit mounted, a distance of 50 mm (2 in) between the units is required.

5.3 Mechanical Installation H13-H14

5.3.1 Tools Needed

Receiving/unloading

- I-beam and hooks rated to lift the weight of the drive. Refer to [5.1 Power Ratings, Weights, and Dimensions](#).
- Crane or other lifting aid to place the unit into position.

Installation

- Drill with a 12 mm (1/2 in) drill bit.
- Tape measurer.
- Phillips and flat bladed screwdrivers.
- Wrench with 7–17 mm metric sockets.
- Wrench extensions.
- T25 and T50 Torx drives.
- Sheet metal punch and/or pliers for cable entry plate.

5.3.2 Installation and Cooling Requirements

N O T I C E

OVERHEATING

Improper mounting can result in overheating and reduced performance.

- Install the drive according to the installation and cooling requirements.

Installation requirements

- Ensure drive stability by mounting the drive vertically to a solid flat surface.
- Ensure that the strength of the mounting location supports the drive weight. Ensure that the mounting location allows access to open the enclosure door. Refer to [5.1 Power Ratings, Weights, and Dimensions](#).
- Ensure that there is enough space around the drive for cooling airflow.
- Place the drive as near to the motor as possible. Keep the motor cables as short as possible. See [9.2.4 Cable Length and Cross-section](#).
- Ensure that the location allows for cable entry at the bottom of the drive.

Cooling and airflow requirements

- Ensure that top and bottom clearance for air cooling is provided. Clearance requirement: 225 mm (9 in).
- Consider derating for temperatures starting between 45 °C (113 °F) and 50 °C (122 °F) and elevation 1000 m (3300 ft) above sea level. See *chapter Derating* for detailed information.

The drive uses back-channel cooling to circulate the heat sink cooling air. The cooling duct carries approximately 90% of the heat out of the back channel of the drive. Redirect the back-channel air from the panel or room by using:

- Duct cooling. Back-channel cooling kits are available to direct the air away from the panel when an IP20/chassis drive is installed in a Rittal enclosure. Use of a kit reduces the heat in the panel and smaller door fans can be specified on the enclosure.
- Cooling out the back (top and base covers). The back-channel cooling air can be ventilated out of the room so that the heat from the back channel is not dissipated into the control room.

N O T I C E

One or more door fans are required on the enclosure to remove heat not contained in the back channel of the drive. The fans also remove any additional losses generated by other components inside the drive.

Design Guide

Ensure that the fans supply adequate airflow over the heat sink. To select the appropriate number of fans, calculate the total required airflow. The flow rate is shown in the following table.

Table 35: Airflow

Enclosure size	Door fan/top fan	Heat sink fan
H13	102 m ³ /hr (60 CFM)	420 m ³ /hr (250 CFM)
H14	204 m ³ /hr (120 CFM)	840 m ³ /hr (500 CFM)

5.3.3 Lifting the Drive

! W A R N I N G !

HEAVY LOAD

Unbalanced loads can fall or tip over. Failure to take proper lifting precautions increases risk of death, serious injury, or equipment damage.

- Move the unit using a hoist, crane, forklift, or other lifting device with the appropriate weight rating. See [5.1 Power Ratings, Weights, and Dimensions](#) for the weight of the drive.
- Failure to locate the center of gravity and correctly position the load can cause unexpected shifting during lifting and transport. For measurements and center of gravity, see [5.1 Power Ratings, Weights, and Dimensions](#).
- The angle from the top of the drive module to the lifting cables affects the maximum load force on the cable. This angle must be 65° or greater. Refer to the following illustration. Attach and dimension the lifting cables properly.
- Never walk under suspended loads.
- To guard against injury, wear personal protective equipment such as gloves, safety glasses, and safety shoes.

Always lift the drive using the dedicated eye bolts at the top of the drive. See the following illustration.

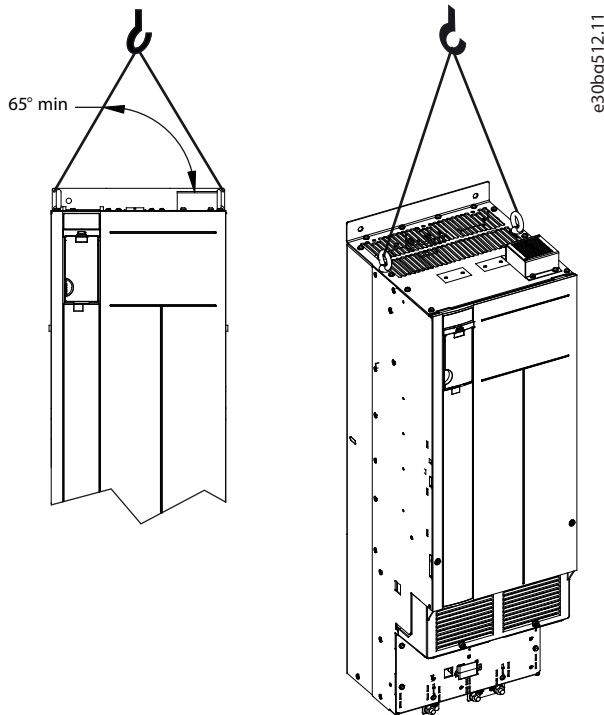

Illustration 42: Lifting the Drive

Design Guide

5.3.4 Wall Mounting the Drive

H13 and H14 are chassis drives intended to be mounted on a wall or on a mounting plate within an enclosure. To wall mount the drive, use the following steps.

Procedure

1. Fasten 2 M10 bolts in the wall to align with the fastener slots at the bottom of drive.
2. Slide the lower fastener slots in the drive over the M10 bolts.
3. Tip the drive against the wall, and secure the top with 2 M10 bolts in the mounting holes.

Example

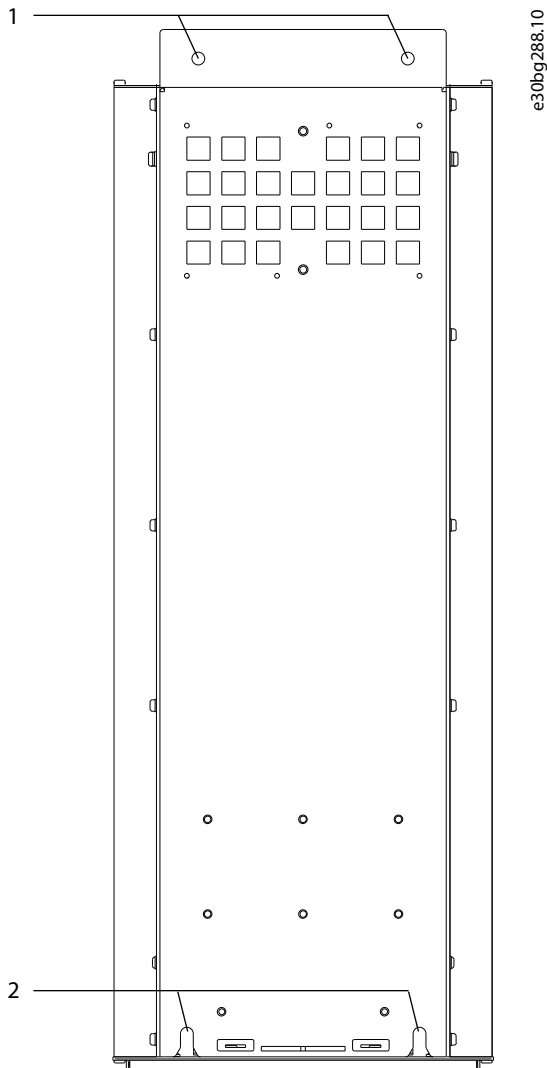

Illustration 43: Drive-to-wall Mounting Holes

- | | |
|---|----------------------|
| 1 | Top mounting holes |
| 2 | Lower fastener slots |

Design Guide

5.3.5 Creating Cable Openings

After installing the drive, create cable openings in the gland plate to accommodate the mains and motor cables. The gland plate is required to maintain the drive protection rating.

Procedure

1. Punch out plastic tabs to accommodate the cables.

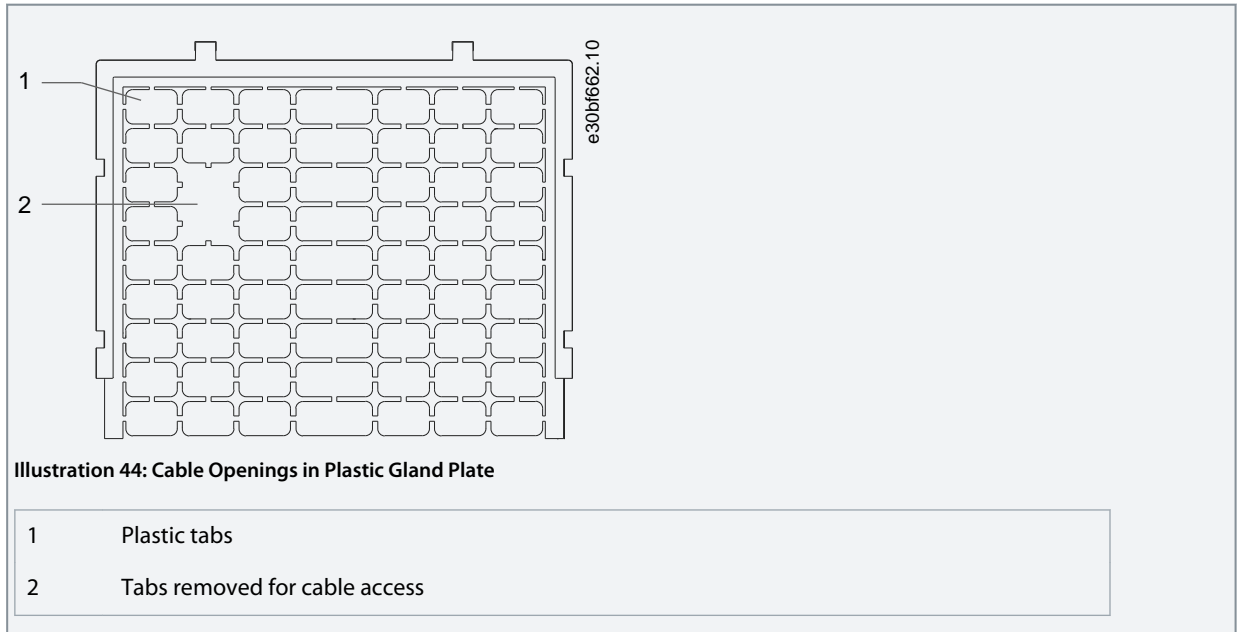

5.3.6 Back-channel Cooling

A unique back-channel duct passes cooling air over the heat sinks with minimal air passing through the electronics area. There is an IP54/Type 12 seal between the back-channel cooling duct and the electronics area of the VLT® drive. This back-channel cooling allows 90% of the heat losses to be exhausted directly outside the enclosure. This design improves reliability and prolongs component life by dramatically reducing interior temperatures and contamination of the electronic components. Different back-channel cooling kits are available to redirect the airflow based on individual needs.

5.3.6.1 Airflow for H13 & H14 Enclosures

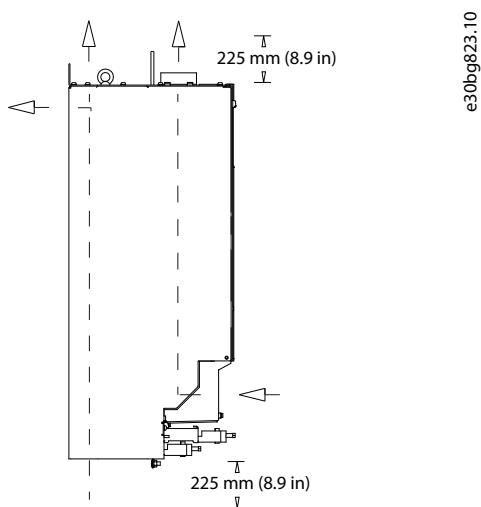

Illustration 45: Standard Airflow Configuration for Enclosures H13 and H14

5.4 Derating

5.4.1 Manual Derating and Automatic Derating

Derating is a method used to reduce output current to avoid tripping the drive when high temperatures are reached within the enclosure. If certain extreme operating conditions are expected, a higher-powered drive can be selected to eliminate the need for derating. This is called manual derating. Otherwise, the drive automatically derates the output current to eliminate the excessive heat generated by extreme conditions.

Manual derating

When the following conditions are present, Danfoss recommends selecting a drive 1 power size higher (for example P132 instead of P110):

- Low-speed – continuous operation at low RPM in constant torque applications.
- Low air pressure – operating at altitudes above 1000 m (3281 ft).
- High ambient temperature – operating at ambient temperatures of 10 °C (50 °F).
- High switching frequency.
- Long motor cables.
- Cables with a large cross-section.

Automatic derating

If the following operating conditions are found, the drive automatically changes switching frequency or switching pattern (PWM to SFAVM) to reduce excessive heat within the enclosure:

- High temperature on the control card or heat sink.
- High motor load or low motor speed.
- High DC-link voltage.

5.4.2 Derating for Low-speed Operation

When a motor is connected to a drive, it is necessary to ensure that the cooling of the motor is adequate. The level of cooling required depends on the following:

- Load on the motor.
- Operating speed.
- Length of operating time.

Constant torque applications (CT mode)

In a constant torque application, a motor may overheat at low speeds because the fan within the motor is providing less cooling air. Therefore, if the motor is to be run continuously at an RPM value lower than half of the rated value, the motor must be supplied with extra air cooling. If extra air cooling is not available, use a motor designed for low RPM/constant torque applications, or select a larger motor to reduce the load level.

Variable (quadratic) torque applications (VT)

In variable torque applications where the torque is proportional to the square of the speed and the power is proportional to the cube of the speed, there is no need for extra cooling or derating of the motor. Common variable torque applications are centrifugal pumps and fans.

5.4.3 Derating for Low Air Pressure and High Altitudes

The cooling capability of air is decreased at low air pressure. For altitudes above 2000 m (6562 ft), contact Danfoss regarding PELV. Below 1000 m (3281 ft) altitude, derating is not necessary. For altitudes above 1000 m (3281 ft), decrease the ambient temperature or the maximum output current. Decrease the output by 1% per 100 m (328 ft) altitude above 1000 m (3281 ft) or reduce the maximum ambient cooling air temperature by 1 °C (1.8 °F) per 200 m (656 ft).

5.4.4 Derating for Ambient Temperature and Switching Frequency

Ensure that the ambient temperature measured over 24 hours is at least 5 °C (9 °F) lower than the maximum ambient temperature that is specified for the drive. If the drive is operated at a high ambient temperature, decrease the constant output current.

N O T I C E

FACTORY DERATING

Danfoss drives have already derated for operational temperature (55 °C (131 °F) $T_{AMB,MAX}$ and 50 °C (122 °F) $T_{AMB,AVG}$).

Design Guide

Use the following graphs to determine if the output current must be derated based on switching frequency and ambient temperature. When referring to the graphs, I_{out} indicates the percentage of rated output current, and f_{sw} indicates the switching frequency.

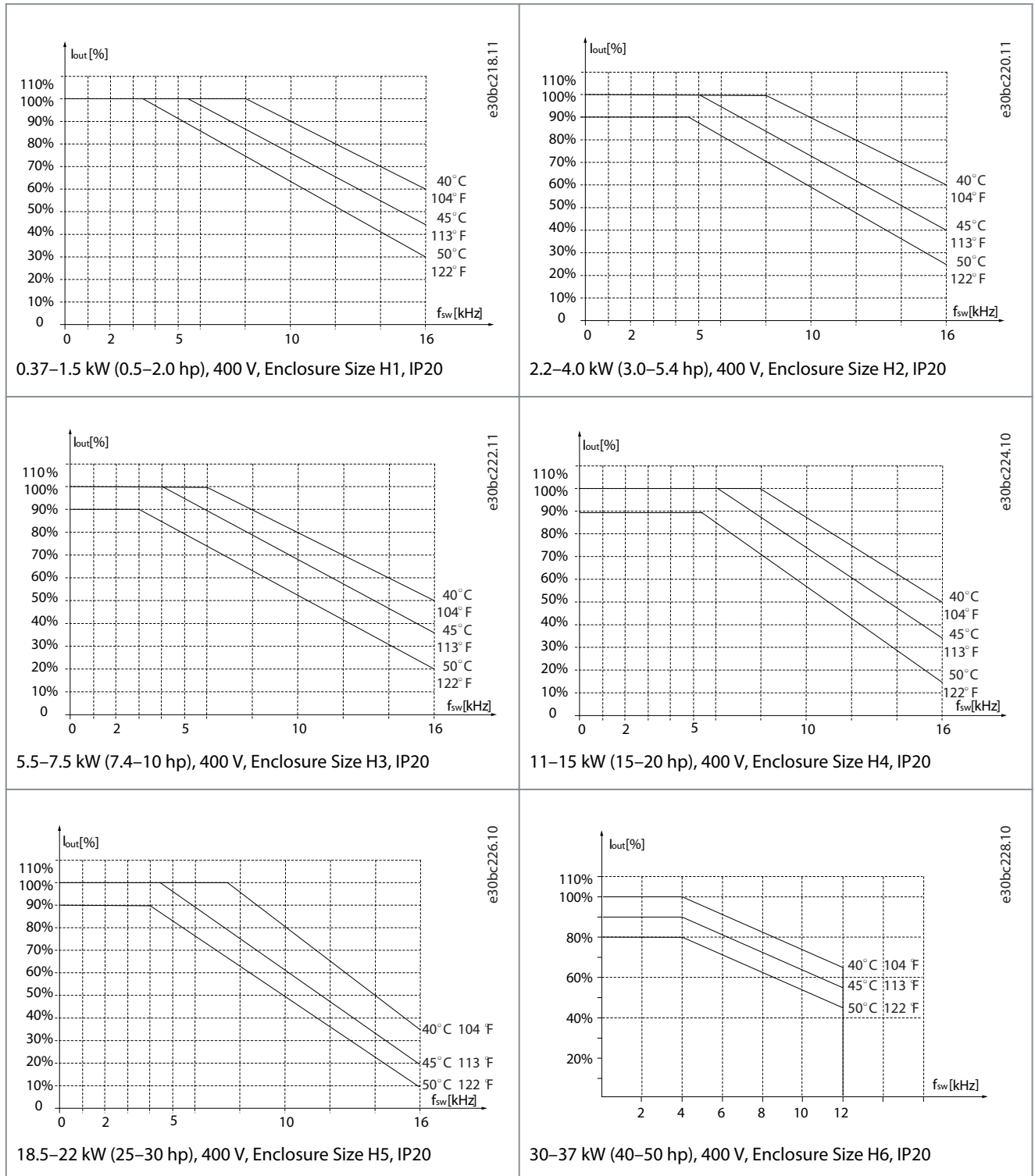

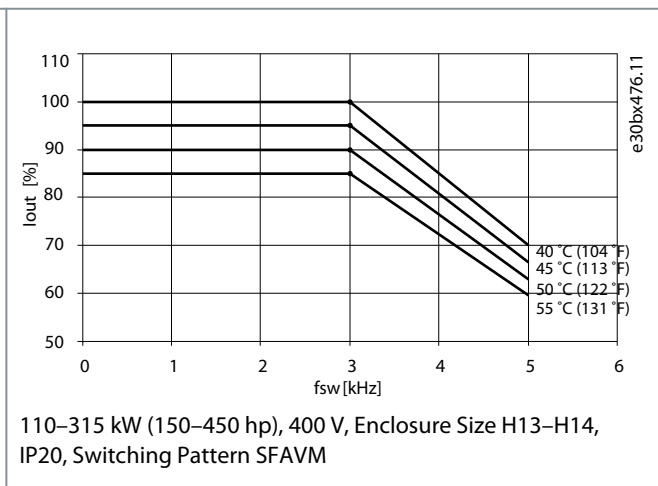
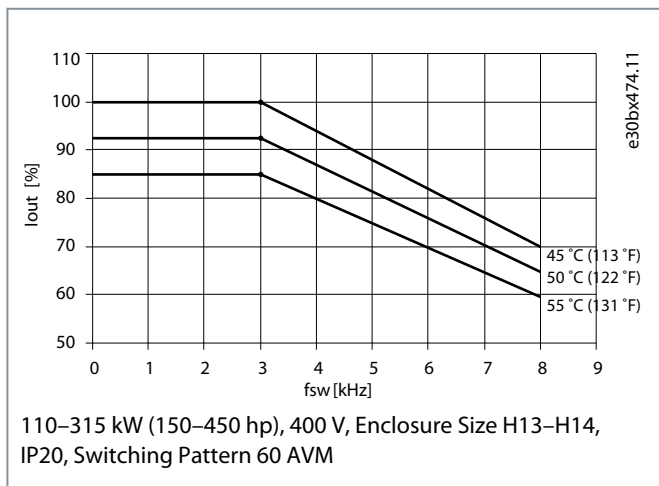
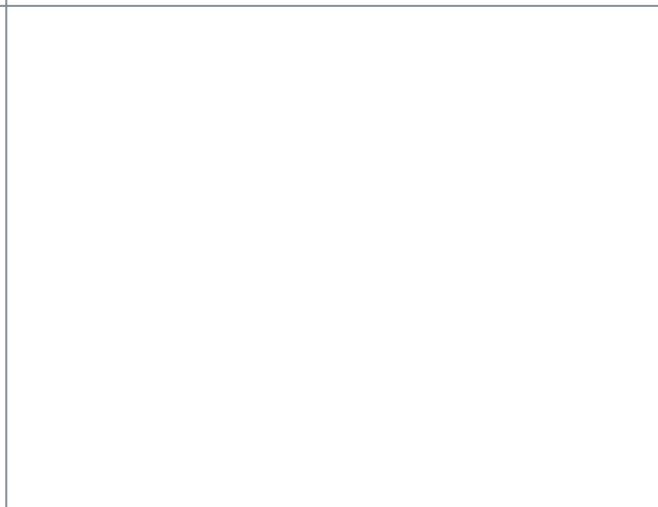
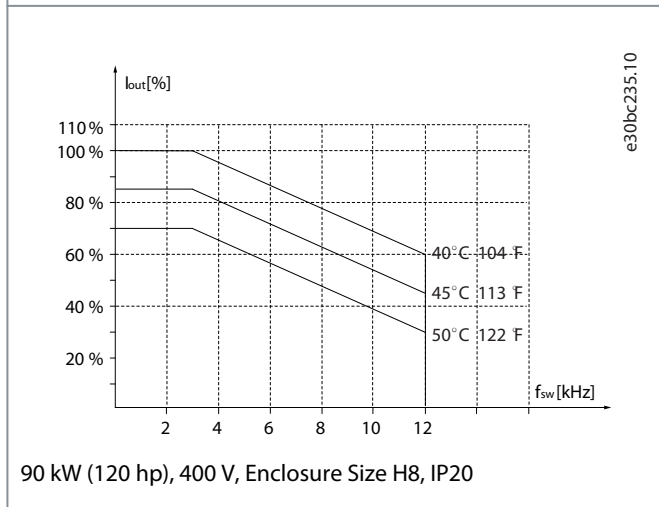
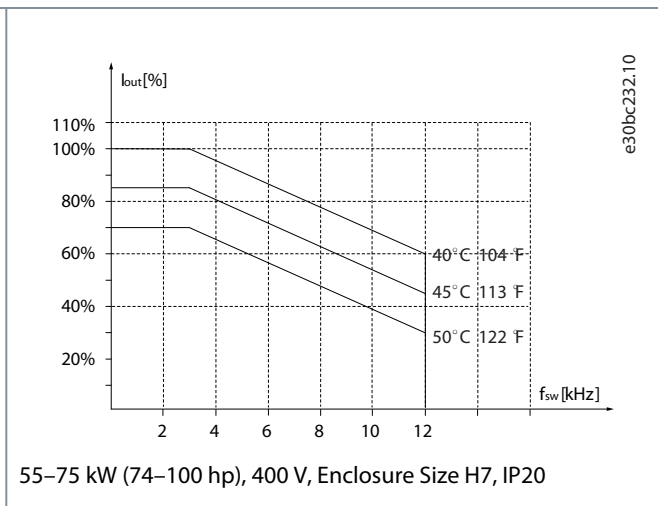
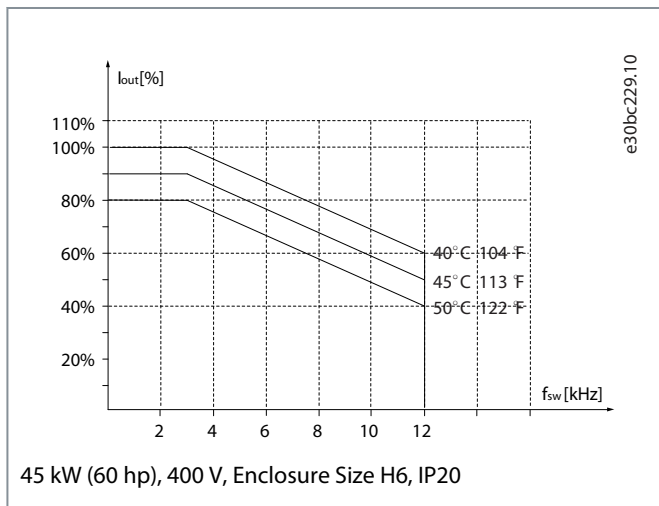

6 Electrical Installation Considerations

6.1 Safety Instructions

See *chapter Safety* for general safety instructions.

⚠ WARNING ⚠

INDUCED VOLTAGE

Induced voltage from output motor cables from different drives that are run together can charge equipment capacitors even with the equipment turned off and locked out. Failure to run output motor cables separately or use shielded cables could result in death or serious injury.

- Run output motor cables separately or use shielded cables.
- Simultaneously lock out all the drives.

⚠ WARNING ⚠

SHOCK HAZARD

The drive can cause a DC current in the ground conductor and thus result in death or serious injury. Failure to follow the recommendation means that the residual current-operated protective device (RCD) cannot provide the intended protection.

- When a residual current-operated protective device (RCD) is used for protection against electrical shock, only an RCD of Type B is allowed on the supply side.

Overcurrent protection

- Additional protective equipment such as short-circuit protection or motor thermal protection between drive and motor is required for applications with multiple motors.
- Input fusing is required to provide short circuit and overcurrent protection. If fuses are not factory-supplied, the installer must provide them. See maximum fuse ratings in *chapter Fuses and Circuit Breakers*.

Wire type and ratings

- All wiring must comply with local and national regulations regarding cross-section and ambient temperature requirements.
- Power connection wire recommendation: Minimum 75 °C (167 °F) rated copper wire.

See [9.2.4 Cable Length and Cross-section](#) for recommended wire sizes and types.

Design Guide

6.2 Electrical Wiring

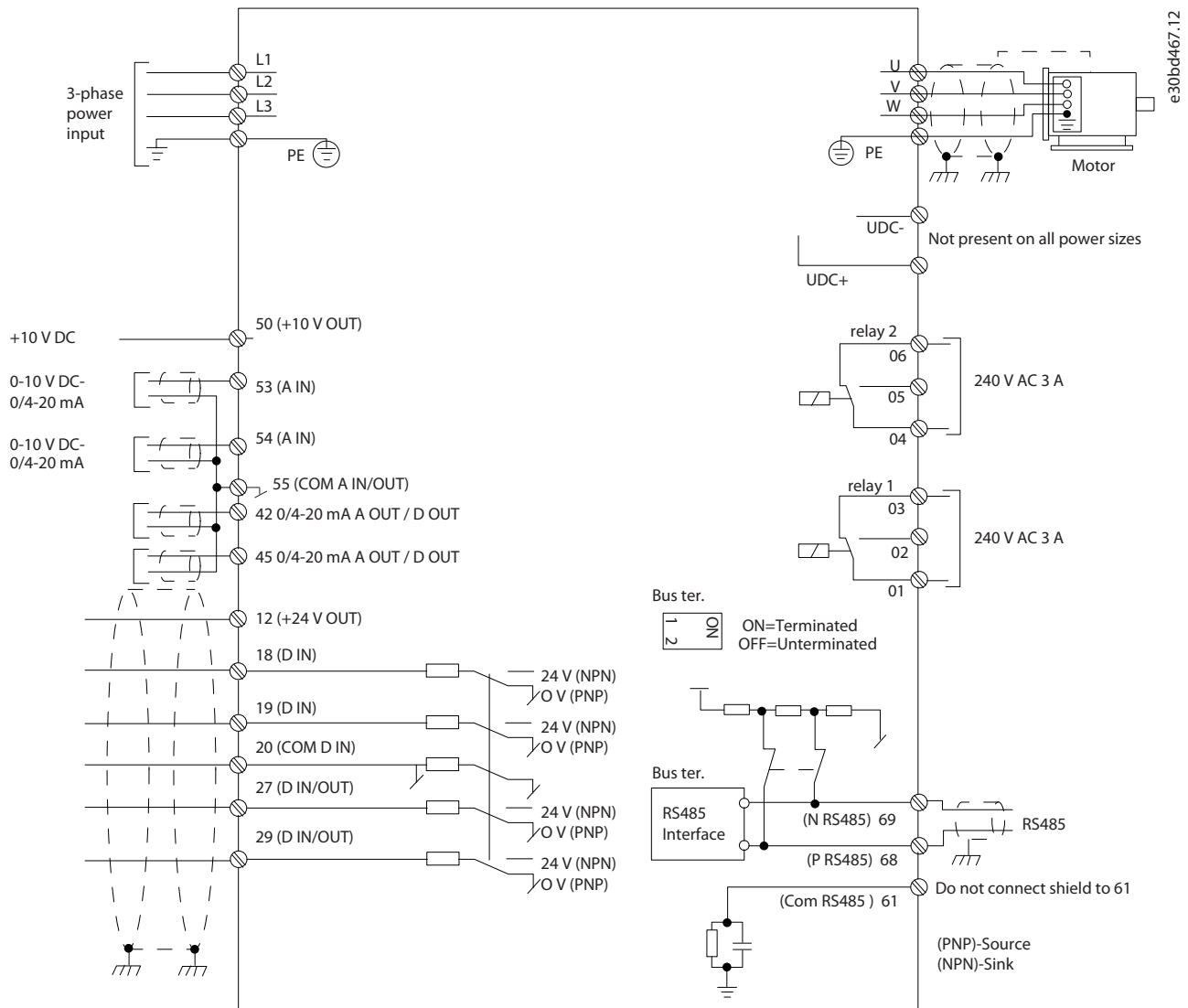

Illustration 46: Basic Wiring Schematic Drawing

NOTICE

There is no access to UDC- and UDC+ on the following units:

- IP20, 380-480 V, 30-315 kW (40-450 hp)

6.3 EMC-compliant Electrical Installation

To ensure EMC-correct electrical installation, observe the following:

- Use only shielded/armored motor cables and shielded/armored control cables.
- Ground the shield at both ends.
- Avoid installation with twisted shield ends (pigtailed), because it reduces the shielding effect at high frequencies. Use the cable clamps provided.
- Ensure the same potential between the drive and the ground potential of PLC.
- Use star washers and galvanically conductive installation plates.

e30bb761.13

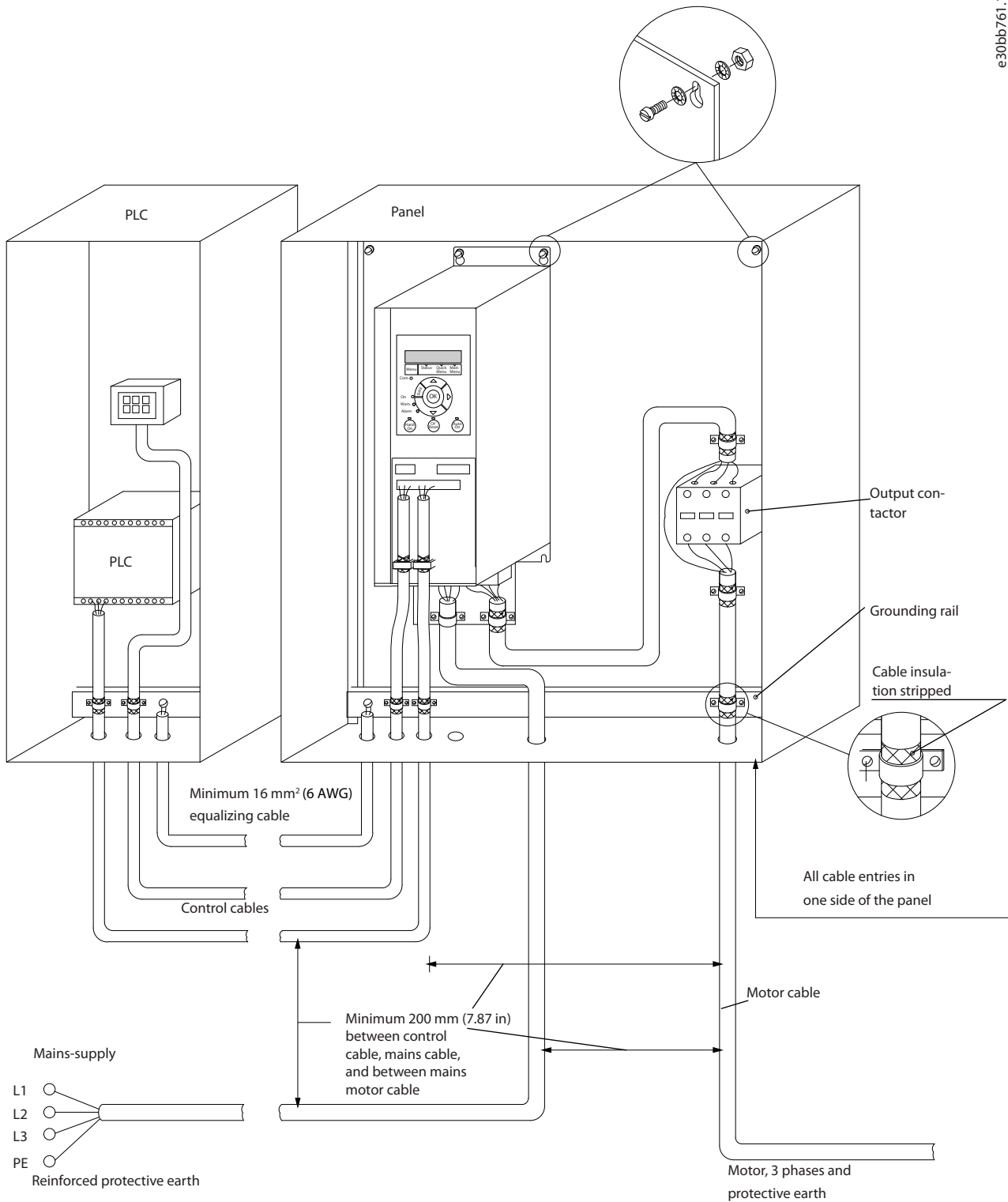

Illustration 47: EMC-compliant Installation

Design Guide

6.4 Relays and Terminals

6.4.1 Relays and Terminals on Enclosure Sizes H1–H5

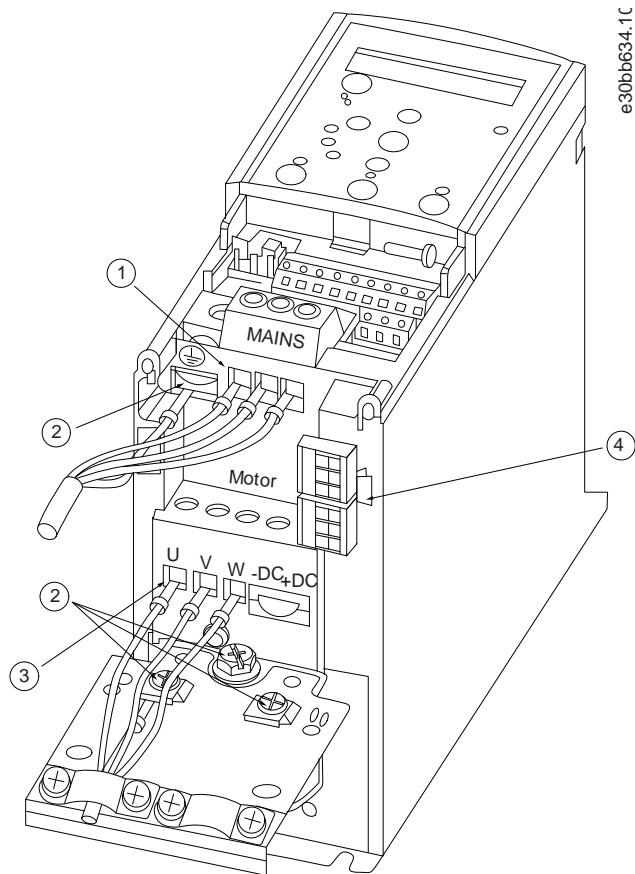

Illustration 48: Enclosure Sizes H1–H5 IP20, 380–480 V, 0.37–22 kW (0.5–30 hp)

1	Mains	3	Motor
2	Ground	4	Relays

Design Guide

6.4.2 Relays and Terminals on Enclosure Size H6

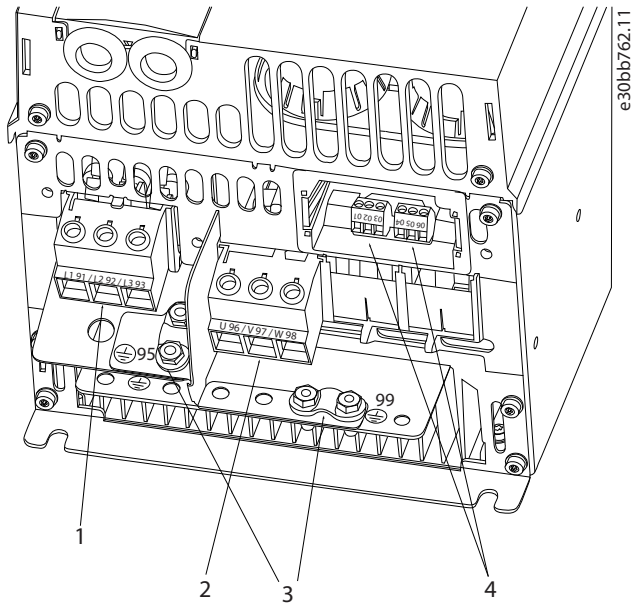

Illustration 49: Enclosure Size H6 IP20, 380–480 V, 30–45 kW (40–60 hp)

1	Mains	3	Ground
2	Motor	4	Relays

6.4.3 Relays and Terminals on Enclosure Size H7

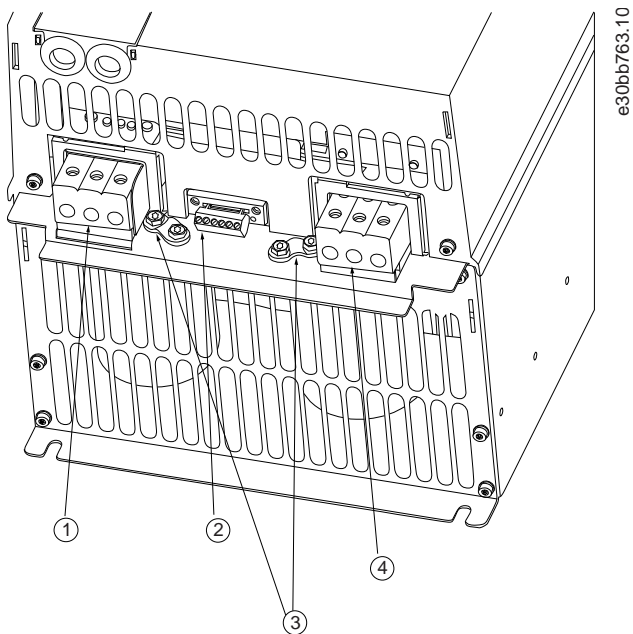

Illustration 50: Enclosure Size H7 IP20, 380–480 V, 55–75 kW (70–100 hp)

Design Guide

1	Mains	3	Ground
2	Relays	4	Motor

6.4.4 Relays and Terminals on Enclosure Size H8

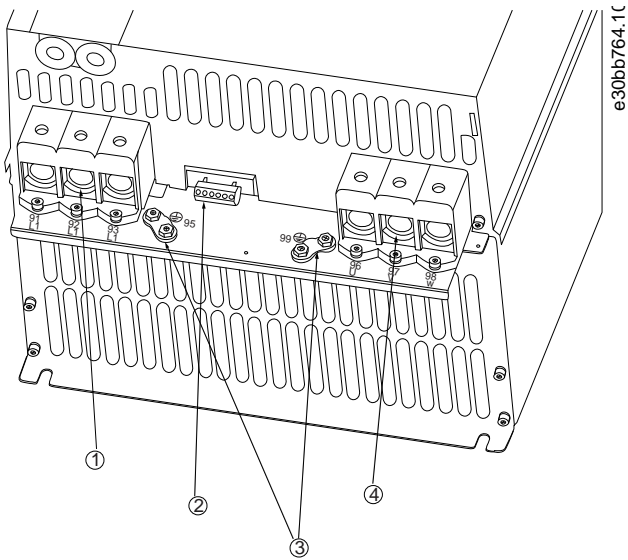

Illustration 51: Enclosure Size H8 IP20, 380–480 V, 90 kW (125 hp)

1	Mains	3	Ground
2	Relays	4	Motor

6.4.5 Relays and Terminals on Enclosure Size H13–H14

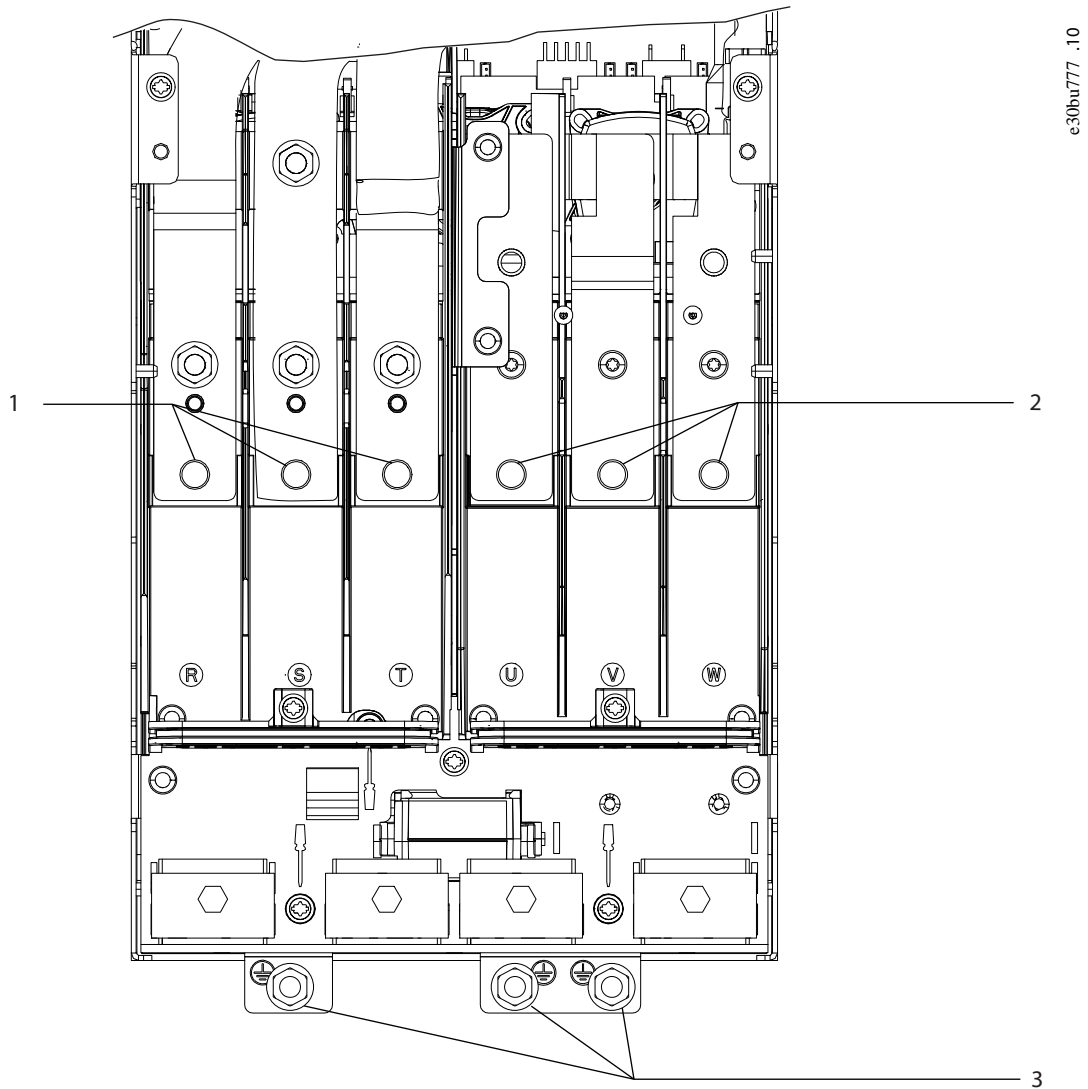

Illustration 52: Enclosure Size H13–H14 IP20, 380–480 V, 110–315 kW (150–450 hp)

1	Mains	3	Ground
2	Motor		

See [6.5 View of Control Shelf](#) for the relay terminals of H13–H14 drives.

6.5 View of Control Shelf

The control shelf of H13–H14 drives holds the keypad, known as the local control panel or LCP. The control shelf also includes the control terminals, relays, and various connectors.

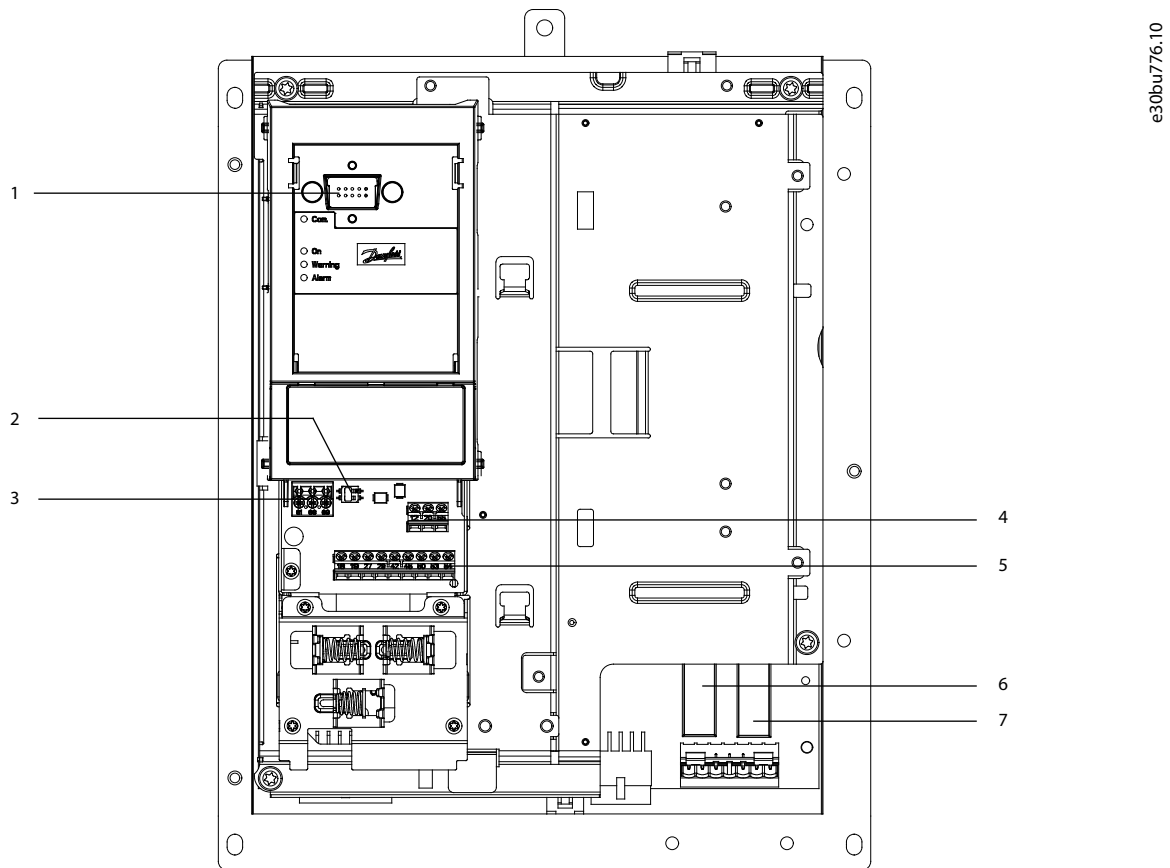

Illustration 53: View of Control Shelf in H13-H14

1	LCP connector	5	Digital I/O and 24 V supply
2	RS485 termination switch	6	Relay 1 on power card
3	RS485 fieldbus connector	7	Relay 2 on power card
4	Analog I/O connector		

6.6 Fastener Tightening Torques

Apply the correct torque when tightening fasteners in the locations that are listed in the following tables. Too low or too high torque when fastening an electrical connection results in a bad electrical connection. To ensure correct torque, use a torque wrench.

Table 36: Tightening Torques for Enclosure Sizes H1-H8, 3x380-480 V

Power [kW (hp)]			Torque [Nm (in-lb)]					
Enclosure size	IP class	3x380-480 V	Mains	Motor	DC connection	Control terminals	Ground	Relay
H1	IP20	0.37-1.5 (0.5-2.0)	0.8 (7)	0.8 (7)	0.8 (7)	0.5 (4)	0.8 (7)	0.5 (4)
H2	IP20	2.2-4.0 (3.0-5.4)	0.8 (7)	0.8 (7)	0.8 (7)	0.5 (4)	0.8 (7)	0.5 (4)
H3	IP20	5.5-7.5 (7.5-10)	0.8 (7)	0.8 (7)	0.8 (7)	0.5 (4)	0.8 (7)	0.5 (4)
H4	IP20	11-15 (15-20)	1.2 (11)	1.2 (11)	1.2 (11)	0.5 (4)	0.8 (7)	0.5 (4)
H5	IP20	18.5-22 (25-30)	1.2 (11)	1.2 (11)	1.2 (11)	0.5 (4)	0.8 (7)	0.5 (4)
H6	IP20	30-45 (40-60)	4.5 (40)	4.5 (40)	-	0.5 (4)	3 (27)	0.5 (4)

Design Guide

Power [kW (hp)]			Torque [Nm (in-lb)]					
H7	IP20	55 (70)	10 (89)	10 (89)	–	0.5 (4)	3 (27)	0.5 (4)
H7	IP20	75 (100)	14 (124)	14 (124)	–	0.5 (4)	3 (27)	0.5 (4)
H8	IP20	90 (125)	24 (212) ⁽¹⁾	24 (212) ⁽¹⁾	–	0.5 (4)	3 (27)	0.5 (4)

¹ Cable dimensions >95 mm².

Table 37: Tightening Torques for Enclosure Sizes H13–H14, 3x380–480 V

Location	Bolt size	Torque [Nm (in-lb)]
Mains terminals	M10/M12	19 (168)/37 (335)
Motor terminals	M10/M12	19 (168)/37 (335)
Ground terminals	M8/M10	9.6 (84)/19.1 (169)
Relay terminals	–	0.5 (4)
Door/panel cover	M5	2.3 (20)
Gland plate	M5	2.3 (20)

6.7 IT Mains

! CAUTION !

IT MAINS

Installation on isolated mains source, that is, IT mains.

- Ensure that the supply voltage does not exceed 440 V (3x380–480 V units) when connected to mains.

For 380–480 V, IP20, 0.37–22 kW (0.5–30 hp) units, open the RFI switch by removing the screw on the side of the drive when at IT grid.

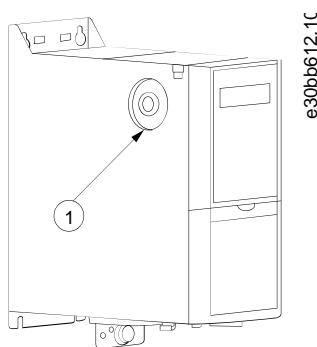

Illustration 54: IP20, 0.37–22 kW (0.5–30 hp), 380–480 V

- | | |
|---|-----------|
| 1 | EMC screw |
|---|-----------|

NOTICE

If reinserted, use only M3x12 screw.

For 380–480 V, 30–90 kW (40–125 hp) units, set *parameter 14-50 RFI Filter* to [0] Off when operating in IT mains.

For 380–480 V, 110–315 kW (150–450 hp) units, if the drive is supplied from an isolated mains source (IT mains, floating delta, or grounded delta) or TT/TN-S mains with grounded leg, the RFI switch is recommended to be turned off via *parameter 14-50 RFI Filter*

Design Guide

on the drive and *parameter 14-50 RFI Filter* on the filter. For more detail, see IEC 364-3. In the *[Off]* position, the filter capacitors between the chassis and the DC link are cut off to avoid damage to the DC link and to reduce the ground capacity currents, according to IEC 61800-3.

If optimum EMC performance is needed, or parallel motors are connected, or the motor cable length is above 25 m (82 ft), Danfoss recommends setting *parameter 14-50 RFI Filter* to *[On]*. It is important to use isolation monitors that are rated for use together with power electronics (IEC 61557-8).

6.8 Mains and Motor Connection

6.8.1 Introduction

The drive is designed to operate all standard 3-phase asynchronous motors.

- Use a shielded/armored motor cable to comply with EMC emission specifications and connect this cable to both the decoupling plate and the motor.
- Keep the motor cable as short as possible to reduce the noise level and leakage currents.
- For further details on mounting the decoupling plate, see the *Decoupling Plate Mounting Instructions*.
- Also see EMC-Correct Installation in the [6.3 EMC-compliant Electrical Installation](#).

6.8.2 Connecting to the Ground

! W A R N I N G

LEAKAGE CURRENT HAZARD

Leakage currents exceed 3.5 mA. Failure to ground the drive properly can result in death or serious injury.

- Ensure that the minimum size of the ground conductor complies with the local safety regulations for high touch current equipment.

For electrical safety:

- Ground the drive in accordance with applicable standards and directives.
- Use a dedicated ground wire for input power, motor power, and control wiring.
- Do not ground 1 drive to another in a daisy chain fashion.
- Keep the ground wire connections as short as possible.
- Follow motor manufacturer wiring requirements.
- Minimum cable cross-section: 10 mm² (8 AWG) Cu or 16 mm² (6 AWG) Al (or 2 rated ground wires terminated separately).
- Tighten the terminals in accordance with the information provided in [6.6 Fastener Tightening Torques](#).

For EMC-compliant installation

- Establish electrical contact between the cable shield and the drive enclosure by using metal cable glands or by using the clamps provided on the equipment.
- Reduce burst transient by using high-strand wire.
- Do not use twisted shield ends (pigtailed).

N O T I C E

POTENTIAL EQUALIZATION

There is a risk of burst transient when the ground potential between the drive and the control system is different.

- Install equalizing cables between the system components. Recommended cable cross-section: 16 mm² (6 AWG).

6.8.3 Connecting the Motor

⚠ W A R N I N G ⚠

INDUCED VOLTAGE

Induced voltage from output motor cables that run together can charge equipment capacitors, even with the equipment turned off and locked out/tagged out. Failure to run output motor cables separately or to use shielded cables could result in death or serious injury.

- Run output motor cables separately or use shielded cables.
- Simultaneously lock out/tag out all the drives.

- Comply with local and national electrical codes for cable sizes. For maximum wire sizes, see [9.2.4 Cable Length and Cross-section](#).
- Follow motor manufacturer wiring requirements.
- Motor wiring knockouts or access panels are provided at the base of IP21 (NEMA1/12) and higher units.
- Do not wire a starting or pole-changing device (for example, Dahlander motor or slip ring asynchronous motor) between the drive and the motor.

Procedure

1. Strip a section of the outer cable insulation.
2. Position the stripped wire under the cable clamp, establishing mechanical fixation and electrical contact between the cable shield and ground.
3. Connect the ground wire to the nearest grounding terminal in accordance with the grounding instructions provided in [6.8.2 Connecting to the Ground](#).
4. Connect the 3-phase motor wiring to terminals U, V, and W.
5. Tighten the terminals in accordance with the information provided in [6.6 Fastener Tightening Torques](#).

6.8.4 Connecting the AC Mains

- Size the wiring according to the input current of the drive. For maximum wire sizes, see [9.1.1 3x380–480 V AC](#).
- Comply with local and national electrical codes for cable sizes.

Procedure

1. Strip a section of the outer cable insulation.
2. Position the stripped wire under the cable clamp, establishing mechanical fixation and electrical contact between the cable shield and ground.
3. Connect the ground wire to the nearest grounding terminal in accordance with the grounding instructions provided in [6.8.2 Connecting to the Ground](#).
4. For H1-H8 drives, connect the 3-phase AC input power wiring to terminals L1, L2, and L3.
5. For H13-H14 drives, connect the 3-phase AC input power wiring to terminals R, S, and T.
6. When supplied from an isolated mains source (IT mains or floating delta) or TT/TN-S mains with a grounded leg (grounded delta), ensure that *parameter 14-50 RFI Filter* is set to [0] Off to avoid damage to the DC link and to reduce ground capacity currents.
7. Tighten the terminals in accordance with the information provided in [6.6 Fastener Tightening Torques](#).

6.9 Fuses and Circuit Breakers

6.9.1 Branch Circuit Protection

To prevent fire hazards, protect the branch circuits in an installation, switch gear, machines, and so on, against short circuits and overcurrent. Follow national and local regulations.

6.9.2 Short-circuit Protection

Danfoss recommends using the fuses and circuit breakers listed in this chapter to protect service personnel or other equipment in case of an internal failure in the unit or a short circuit on the DC link. The drive provides full short-circuit protection in case of a short circuit on the motor.

Design Guide

6.9.3 Overcurrent Protection

Provide overload protection to avoid overheating of the cables in the installation. Overcurrent protection must always be carried out according to local and national regulations. Design circuit breakers and fuses for protection in a circuit capable of supplying a maximum of 100000 A_{rms} (symmetrical), 480 V maximum.

6.9.4 CE Compliance

To ensure compliance with IEC 61800-5-1, use the circuit breakers or fuses listed in this chapter. Circuit breakers must be designed for protection in a circuit capable of supplying a maximum of 10000 A_{rms} (symmetrical), 480 V maximum.

6.9.5 Recommendation of Fuses and Circuit Breakers

N O T I C E

In the event of malfunction, failure to follow the protection recommendation may result in damage to the drive.

Table 38: Fuses and Circuit Breakers

3x380–480 V IP20 kW (hp)	Circuit breaker	Maximum fuse
0.37 (0.5)	–	gG-10
0.75 (1.0)	–	gG-10
1.5 (2.0)	–	gG-10
2.2 (3.0)	–	gG-16
3.0 (4.0)	–	gG-16
4.0 (5.4)	–	gG-16
5.5 (7.5)	–	gG-25
7.5 (10)	–	gG-25
11 (15)	–	gG-50
15 (20)	–	gG-50
18.5 (25)	–	gG-65
22 (30)	–	gG-65
30 (40)	Moeller NZMB1- A125	gG-80
37 (50)	Moeller NZMB1- A125	gG-100
45 (60)	Moeller NZMB1- A125	gG-125
55 (70)	Moeller NZMB1- A200	gG-150
75 (100)	Moeller NZMB1- A200	gG-200
90 (125)	Moeller NZMB2- A250	gG-250
110 (150)	–	aR-315
132 (175)	–	aR-350
160 (250)	–	aR-400
200 (300)	–	aR-500
250 (350)	–	aR-630

Design Guide

315 (450)	-	aR-800
-----------	---	--------

Table 39: H13–H14 Power/semiconductor Fuse Options, 380–480 V

Model	Fuse Options						
	Bussman	Littelfuse	Littelfuse	Bussman	Siba	Ferraz-Shawmut	Ferraz-Shawmut(Europe)
P110	170M2619	LA50QS300-4	L50S-300	FWH-300A	20 189 20.315	A50QS300-4	6,9URD31D08A0315
P132	170M2620	LA50QS350-4	L50S-350	FWH-350A	20 189 20.350	A50QS350-4	6,9URD31D08A0350
P160	170M2621	LA50QS400-4	L50S-400	FWH-400A	20 189 20.400	A50QS400-4	6,9URD31D08A0400
P200	170M4015	LA50QS500-4	L50S-500	FWH-500A	20 189 20.550	A50QS500-4	6,9URD31D08A0550
P250	170M4016	LA50QS600-4	L50S-600	FWH-600A	20 189 20.630	A50QS600-4	6,9URD31D08A0630
P315	170M4017	LA50QS800-4	L50S-800	FWH-800A	20 189 20.800	A50QS800-4	6,9URD32D08A0800

6.10 Control Terminals

Remove the terminal cover (H1-H8) or the cradle cover (H13-H14) to access the control terminals.

H1-H8

Use a flat-edged screwdriver to push down the lock lever of the terminal cover under the LCP, then remove the terminal cover as shown in [Illustration 55](#).

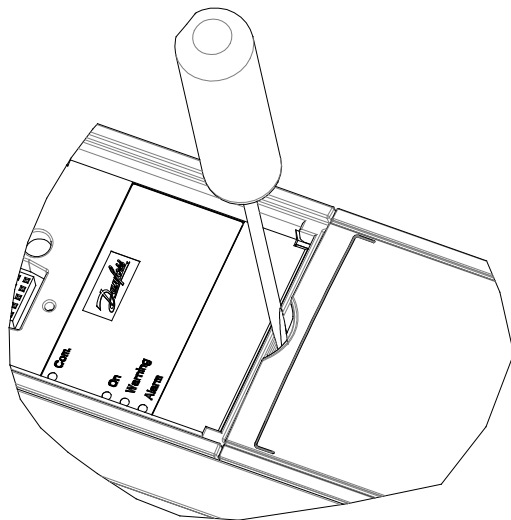

e30bd331.11

Illustration 55: Removing the Terminal Cover

H13-H14

Press the tips of the cradle cover inwards as shown in [Illustration 56](#), and then lift the cradle cover up.

Design Guide

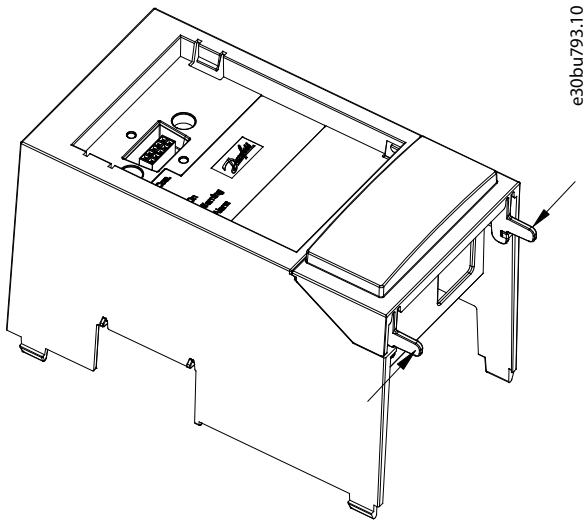

Illustration 56: Removing the Cradle Cover

All the drive control terminals are shown in [Illustration 57](#). Applying start (terminal 18), connection between terminals 12-27, and an analog reference (terminal 53 or 54, and 55) make the drive run.

The digital input mode of terminal 18, 19, and 27 is set in *parameter 5-00 Digital Input Mode* (PNP is default value). Digital input 29 mode is set in *parameter 5-03 Digital Input 29 Mode* (PNP is default value).

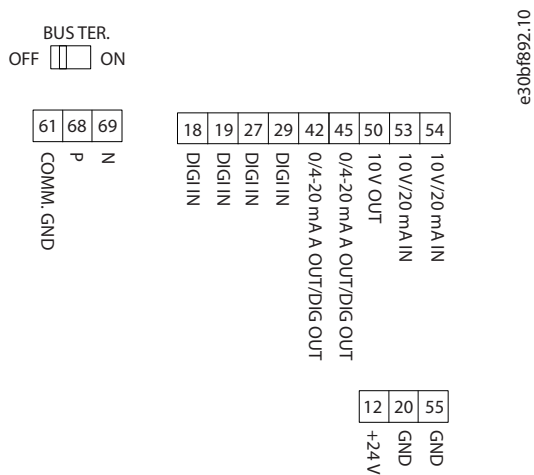

Illustration 57: Control Terminals

6.11 Efficiency

6.11.1 Efficiency of the Drive

The load on the drive has little effect on its efficiency. In general, the efficiency is the same at the rated motor frequency $f_{M,N}$. This rule also applies even if the motor supplies 100% of the rated shaft torque or only 75%, for example if there is part loads.

This also means that the efficiency of the drive does not change even if other U/f characteristics are selected.

However, the U/f characteristics influence the efficiency of the motor.

The efficiency declines a little when the switching frequency is set to a value above the default value. If the mains voltage is 480 V, or if the motor cable is longer than 30 m (98.4 ft), the efficiency is also slightly reduced.

Calculate the efficiency of the drive (η_{VLT}) at different loads based on the following illustration. Multiply the factor in the following illustration by the specific efficiency factor listed in the specification tables.

Design Guide

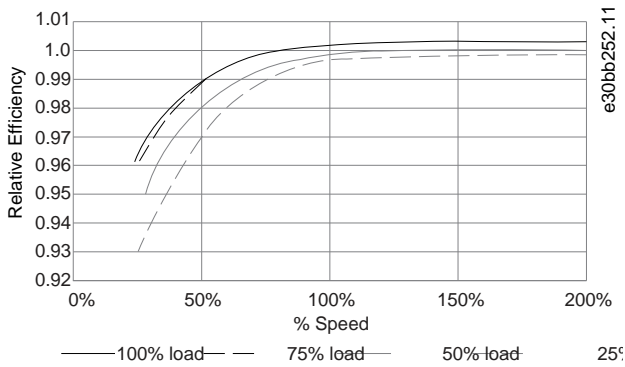

Illustration 58: Typical Efficiency Curves

6.11.2 Efficiency of the Motor

The efficiency of a motor (η_{MOTOR}) connected to the drive depends on the magnetizing level. In general, the efficiency is as good as with mains operation. The efficiency of the motor depends on the type of motor.

In the range of 75–100% of the rated torque, the efficiency of the motor is practically constant, both when controlled by the drive and when running directly on mains.

In small motors, the influence from the U/f characteristic on efficiency is marginal. However, in motors from 11 kW (15 hp) and up, the advantages are significant.

In general, the switching frequency does not affect the efficiency of small motors. Motors from 11 kW (15 hp) and up have their efficiency improved 1–2% because the sine shape of the motor current is almost perfect at high switching frequency.

6.11.3 Efficiency of the System

To calculate the system efficiency (η_{SYSTEM}), the efficiency of the drive (η_{VLT}) is multiplied by the efficiency of the motor (η_{MOTOR}):

$$\eta_{SYSTEM} = \eta_{VLT} \times \eta_{MOTOR}$$

6.12 dU/dt Conditions

6.12.1 dU/dt Overview

NOTICE

To avoid the premature aging of motors that are not designed to be used with drives, such as those motors without phase insulation paper or other insulation reinforcement, Danfoss strongly recommends a dU/dt filter or a sine-wave filter fitted on the output of the drive. For further information about dU/dt and sine-wave filters, see the *Output Filters Design Guide*.

When a transistor in the inverter bridge switches, the voltage across the motor increases by a dU/dt ratio depending on the motor cable (type, cross-section, length shielded or unshielded) and the inductance.

The natural induction causes an overshoot U_{PEAK} in the motor voltage before it stabilizes itself at a level depending on the voltage in the intermediate circuit. The rise time and the peak voltage U_{PEAK} affect the service life of the motor. In particular, motors without phase coil insulation are affected if the peak voltage is too high. Motor cable length affects the rise time and peak voltage. If the motor cable is short (a few meters), the rise time and peak voltage are lower. If the motor cable is long (100 m (328 ft)), the rise time and peak voltage are higher.

Peak voltage on the motor terminals is caused by the switching of the IGBTs. The drive complies with the demands of IEC 60034-25:2007 edition 2.0 regarding motors designed to be controlled by drives. The drive also complies with IEC 60034-17:2006 edition 4 regarding Norm motors controlled by drives.

6.12.2 dU/dt Test Results for H1–H8

Table 40: dU/dt Test Results for H1–H8

	Cable length [m (ft)]	AC line voltage [V]	Rise time [μ sec]	V_{peak} [kV]	dU/dt [kV/ μ sec]
400 V 0.37 kW (0.5 hp)	5 (16)	400	0.160	0.808	4.050
	25 (82)	400	0.240	1.026	3.420

Design Guide

	Cable length [m (ft)]	AC line voltage [V]	Rise time [μsec]	V _{peak} [kV]	dU/dt [kV/μsec]
	50 (164)	400	0.340	1.056	2.517
400 V 0.75 kW (1.0 hp)	5 (16)	400	0.160	0.808	4.050
	25 (82)	400	0.240	1.026	3.420
	50 (164)	400	0.340	1.056	2.517
400 V 1.5 kW (2.0 hp)	5 (16)	400	0.160	0.808	4.050
	25 (82)	400	0.240	1.026	3.420
	50 (164)	400	0.340	1.056	2.517
400 V 2.2 kW (3.0 hp)	5 (16)	400	0.190	0.760	3.200
	25 (82)	400	0.293	1.026	2.801
	50 (164)	400	0.422	1.040	1.971
400 V 3.0 kW (4.0 hp)	5 (16)	400	0.190	0.760	3.200
	25 (82)	400	0.293	1.026	2.801
	50 (164)	400	0.422	1.040	1.971
400 V 4.0 kW (5.4 hp)	5 (16)	400	0.190	0.760	3.200
	25 (82)	400	0.293	1.026	2.801
	50 (164)	400	0.422	1.040	1.971
400 V 5.5 kW (7.4 hp)	5 (16)	400	0.168	0.81	3.857
	25 (82)	400	0.239	1.026	3.434
	50 (164)	400	0.328	1.05	2.560
400 V 7.5 kW (10 hp)	5 (16)	400	0.168	0.81	3.857
	25 (82)	400	0.239	1.026	3.434
	50 (164)	400	0.328	1.05	2.560
400 V 11 kW (15 hp)	5 (16)	400	0.116	0.69	4.871
	25 (82)	400	0.204	0.985	3.799
	50 (164)	400	0.316	1.01	2.563
400 V 15 kW (20 hp)	5 (16)	400	0.139	0.864	4.955
	50 (82)	400	0.338	1.008	2.365
400 V 18.5 kW (25 hp)	5 (16)	400	0.132	0.88	5.220
	25 (82)	400	0.172	1.026	4.772
	50 (164)	400	0.222	1.00	3.603
400 V 22 kW (30 hp)	5 (16)	400	0.132	0.88	5.220
	25 (82)	400	0.172	1.026	4.772

Design Guide

	Cable length [m (ft)]	AC line voltage [V]	Rise time [μsec]	V_{peak} [kV]	dU/dt [kV/ μsec]
	50 (164)	400	0.222	1.00	3.603
400 V 30 kW (40 hp)	10 (33)	400	0.376	0.92	1.957
	50 (164)	400	0.536	0.97	1.448
	100 (328)	400	0.696	0.95	1.092
	150 (492)	400	0.8	0.965	0.965
	10 (33)	480	0.384	1.2	2.5
	50 (164)	480	0.632	1.18	1.494
	100 (328)	480	0.712	1.2	1.348
	150 (492)	480	0.832	1.17	1.125
	10 (33)	500	0.408	1.24	2.431
	50 (164)	500	0.592	1.29	1.743
	100 (328)	500	0.656	1.28	1.561
	150 (492)	500	0.84	1.26	1.2
400 V 37 kW (50 hp)	10 (33)	400	0.276	0.928	2.69
	50 (164)	400	0.432	1.02	1.889
	10 (33)	480	0.272	1.17	3.441
	50 (164)	480	0.384	1.21	2.521
	10 (33)	500	0.288	1.2	3.333
	50 (164)	500	0.384	1.27	2.646
400 V 45 kW (60 hp)	10 (33)	400	0.3	0.936	2.496
	50 (164)	400	0.44	0.924	1.68
	100 (328)	400	0.56	0.92	1.314
	150 (492)	400	0.8	0.92	0.92
	10 (33)	480	0.3	1.19	3.173
	50 (164)	480	0.4	1.15	2.3
	100 (328)	480	0.48	1.14	1.9
	150 (492)	480	0.72	1.14	1.267
	10 (33)	500	0.3	1.22	3.253
	50 (164)	500	0.38	1.2	2.526
	100 (328)	500	0.56	1.16	1.657
	150 (492)	500	0.74	1.16	1.254
400 V 55 kW (74 hp)	10 (33)	400	0.46	1.12	1.948

	Cable length [m (ft)]	AC line voltage [V]	Rise time [μ sec]	V _{peak} [kV]	dU/dt [kV/ μ sec]
		480	0.468	1.3	2.222
400 V 75 kW (100 hp)	10 (33)	400	0.502	1.048	1.673
		480	0.52	1.212	1.869
		500	0.51	1.272	1.992
400 V 90 kW (120 hp)	10 (33)	400	0.402	1.108	2.155
		400	0.408	1.288	2.529
		400	0.424	1.368	2.585

6.12.3 High-power Range

The power sizes in the tables in [6.12.4 dU/dt Test Results for H13–H14](#) at the appropriate mains voltages comply with the requirements of IEC 60034-17:2006 edition 4 regarding normal motors controlled by drives, IEC 60034-25:2007 edition 2.0 regarding motors designed to be controlled by drives, and NEMA MG 1-1998 Part 31.4.4.2 for inverter-fed motors. The power sizes in the tables in [6.12.4 dU/dt Test Results for H13–H14](#) do not comply with NEMA MG 1-1998 Part 30.2.2.8 for general purpose motors.

6.12.4 dU/dt Test Results for H13–H14

Table 41: IEC dU/dt Test Results for H13–H14 with Unshielded Cables and No Output Filter, 380–480 V

Power size [kW (hp)]	Cable [m (ft)]	Mains voltage [V]	Rise time [μ s]	Peak voltage [V]	dU/dt [V/ μ s]
90–160 (125–250)	30 (98)	500	0.71	1180	1339
	150 (492)	500	0.76	1423	1497
	300 (984)	500	0.91	1557	1370
200–315 (300–450)	30 (98)	500	1.10	1116	815
	150 (492)	500	2.53	1028	321
	300 (984)	500	1.29	835	517

Table 42: IEC dU/dt Test Results for H13–H14 with Shielded Cables and No Output Filter, 380–480 V

Power size [kW (hp)]	Cable [m (ft)]	Mains voltage [V]	Rise time [μ s]	Peak voltage [V]	dU/dt [V/ μ s]
90–160 (125–250)	30 (98)	500	–	–	–
	150 (492)	500	0.66	1418	1725
	300 (984)	500	0.96	1530	1277
200–315 (300–450)	30 (98)	500	–	–	–
	150 (492)	500	0.56	1261	1820
	300 (984)	500	0.78	1278	1295

7 Programming

7.1 Local Control Panel (LCP)

The LCP is divided into 4 functional sections.

- A. Display
- B. Menu key
- C. Navigation keys and indicator lights
- D. Operation keys and indicator lights

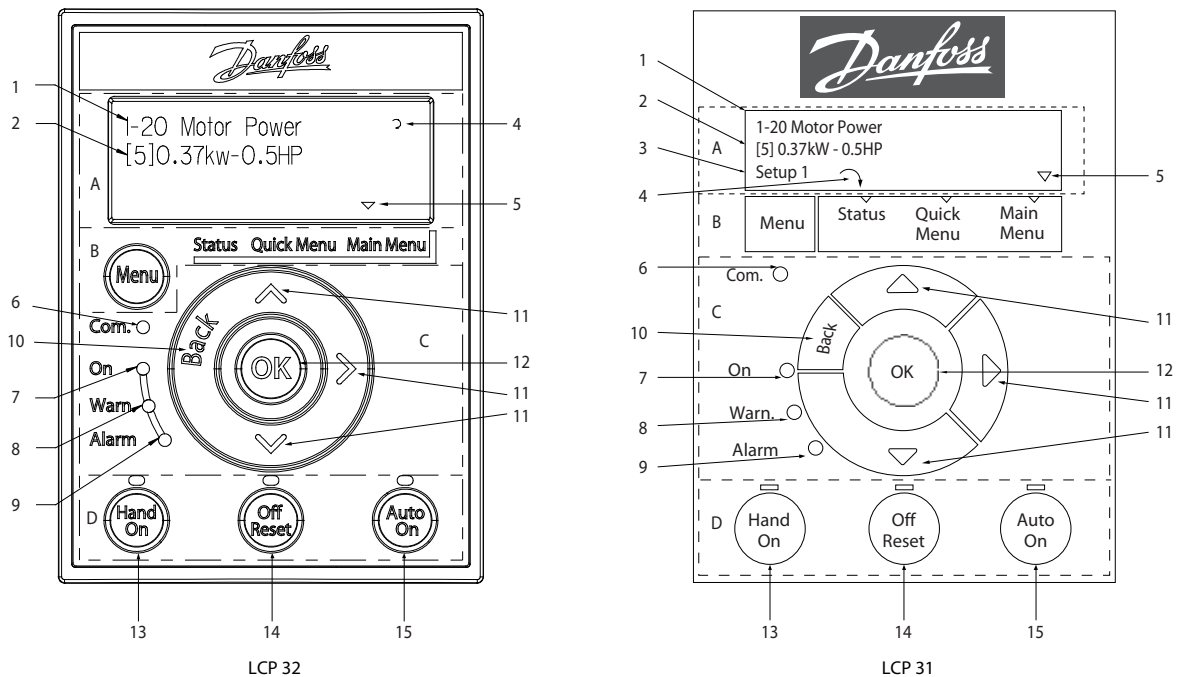

e30bu792.10

Illustration 59: Local Control Panel (LCP)

A. Display

The LCD-display is illuminated with 2 alphanumeric lines. All data is shown on the LCP. The [Table 43](#) describes the information that can be read from the display.

Table 43: Legend to Section A, Illustration 3

1	Parameter number and name.
2	Parameter value.
3	The setup number shows the active setup and the edit setup. For LCP 32, the setup number only shows in Status menu, the number outside brackets is active setup, and the number inside brackets is edit setup. For example, 1(2) means 1 is the active setup, and 2 is the edit setup. For LCP 31, if the same setup acts as both active and edit setup, only that setup number is shown (factory setting). When the active and the edit setup differ, both numbers are shown in the display (setup 12). The number flashing indicates the edit setup.
4	Motor direction is shown to the bottom left of the display – indicated by a small arrow pointing either clockwise or counter-clockwise.
5	The triangle indicates if the LCP is in Status, Quick Menu, or Main Menu.

B. Menu key

Press [Menu] to select among Status, Quick Menu, or Main Menu.

C. Navigation keys and indicator lights

Table 44: Legend to Section C, Illustration 3

6	Com. (yellow indicator): Flashes during bus communication.
7	On (green indicator): Shows the power on status.
8	Warn. (yellow indicator): Indicates a warning.
9	Alarm (red indicator): Indicates an alarm.
10	[Back]: For moving to the previous step or layer in the navigation structure.
11	Up arrow key, down arrow key, and right arrow key: For navigating among parameter groups and parameters, and within parameters. They can also be used for setting local reference.
12	[OK]: For selecting a parameter and for accepting changes to parameter settings.

D. Operation keys and indicator lights

Table 45: Legend to Section D, Illustration 3

13	[Hand On]: Starts the motor and enables control of the drive via the LCP.
<div style="background-color: #cccccc; padding: 5px; border: 1px solid black;"> <p style="margin: 0;">NOTICE</p> <p style="margin: 0;">[2] <i>Coast inverse</i> is the default option for <i>parameter 5-12 Terminal 27 Digital Input</i>. If there is no 24 V supply to terminal 27, [Hand On] does not start the motor. Connect terminal 12 to terminal 27.</p> </div>	
14	[Off/Reset]: Stops the compressor (Off). If in alarm mode, the alarm is reset.
15	[Auto On]: The drive is controlled either via control terminals or serial communication.

7.2 Menus

7.2.1 Status Menu

In the Status menu, the selection options are:

- Motor frequency [Hz], *parameter 16-13 Frequency*.
- Motor current [A], *parameter 16-14 Motor current*.
- Motor speed reference in percentage [%], *parameter 16-02 Reference [%]*.
- Feedback, *parameter 16-52 Feedback [Unit]*.
- Motor power *parameter 16-10 Power [kW]* for kW, *parameter 16-11 Power [hp]* for hp. If *parameter 0-03 Regional Settings* is set to [1] *North America*, motor power is shown in hp instead of kW.
- Custom readout, *parameter 16-09 Custom Readout*.
- Motor Speed [RPM], *parameter 16-17 Speed [RPM]*.

7.2.2 Quick Menu

7.2.2.1 Quick Menu Introduction

Use the Quick Menu to program the most common functions. The Quick Menu consists of:

- Wizard for open-loop applications.
- Wizard for closed-loop applications.
- Motor set-up.
- Changes made.

7.2.2.2 Setup Wizard Introduction

The built-in wizard menu guides the installer through the setup of the drive in a clear and structured manner for open-loop and closed-loop applications, and for quick motor settings.

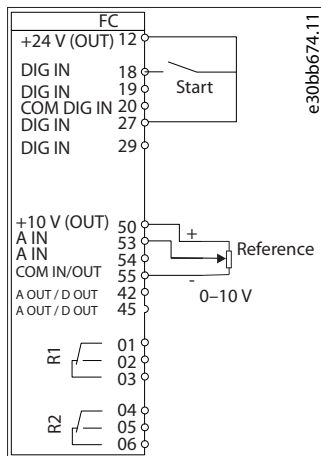
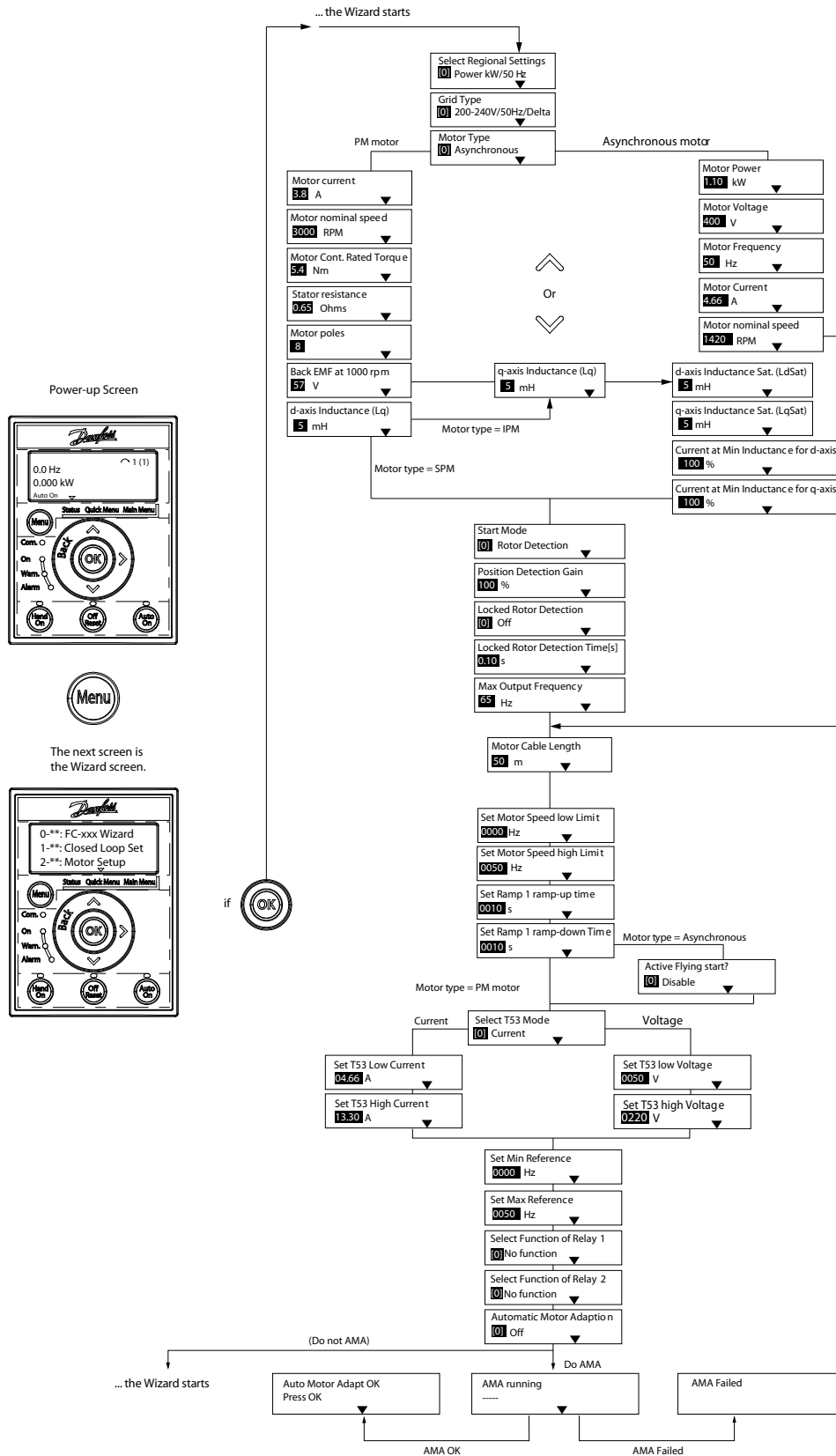

Illustration 60: Drive Wiring

The wizard can always be accessed again through the quick menu. Press [OK] to start the wizard. Press [Back] to return to the status view.

7.2.2.3 Setup Wizard for Open-loop Applications



e30bu808.10

Illustration 61: Setup Wizard for Open-loop Applications

Table 46: Setup Wizard for Open-loop Applications

Parameter	Option	Default	Usage
<i>Parameter 0-03 Regional Settings</i>	[0] International [1] US	[0] International	–
<i>Parameter 0-06 GridType</i>	[10] 380–440 V/50 Hz/IT-grid [11] 380–440 V/50 Hz/Delta [12] 380–440 V/50 Hz [20] 440–480 V/50 Hz/IT-grid [21] 440–480 V/50 Hz/Delta [22] 440–480 V/50 Hz [110] 380–440 V/60 Hz/IT-grid [111] 380–440 V/60 Hz/Delta [112] 380–440 V/60 Hz [120] 440–480 V/60 Hz/IT-grid [121] 440–480 V/60 Hz/Delta [122] 440–480 V/60 Hz	Size related	Select the operating mode for restart after reconnection of the drive to mains voltage after power down. <div style="border: 1px solid black; padding: 5px; text-align: center;"> <p>NOTICE</p> <p>Compared to 380–440 V groups, when selecting 440–480 V groups, the rated current decreases accordingly.</p> </div>
<i>Parameter 1-10 Motor Construction</i>	*[0] Asynchron [1] PM, non-salient SPM [3] PM, salient IPM	[0] Asynchron	Setting the parameter value might change these parameters: <ul style="list-style-type: none"> • <i>Parameter 1-01 Motor Control Principle.</i> • <i>Parameter 1-03 Torque Characteristics.</i> • <i>Parameter 1-08 Motor Control Bandwidth.</i> • <i>Parameter 1-14 Damping Gain.</i> • <i>Parameter 1-15 Low Speed Filter Time Const.</i> • <i>Parameter 1-16 High Speed Filter Time Const.</i> • <i>Parameter 1-17 Voltage Filter Time Const.</i> • <i>Parameter 1-20 Motor Power.</i> • <i>Parameter 1-22 Motor Voltage.</i> • <i>Parameter 1-23 Motor Frequency.</i> • <i>Parameter 1-24 Motor Current.</i> • <i>Parameter 1-25 Motor Nominal Speed.</i> • <i>Parameter 1-26 Motor Cont. Rated Torque.</i> • <i>Parameter 1-30 Stator Resistance (Rs).</i> • <i>Parameter 1-33 Stator Leakage Reactance (X1).</i> • <i>Parameter 1-35 Main Reactance (Xh).</i> • <i>Parameter 1-37 d-axis Inductance (Ld).</i> • <i>Parameter 1-38 q-axis Inductance (Lq).</i> • <i>Parameter 1-39 Motor Poles.</i> • <i>Parameter 1-40 Back EMF at 1000 RPM.</i> • <i>Parameter 1-44 d-axis Inductance Sat. (LdSat).</i> • <i>Parameter 1-45 q-axis Inductance Sat. (LqSat).</i> • <i>Parameter 1-46 Position Detection Gain.</i> • <i>Parameter 1-48 Current at Min Inductance for d-axis.</i> • <i>Parameter 1-49 Current at Min Inductance for q-axis.</i> • <i>Parameter 1-66 Min. Current at Low Speed.</i>

Parameter	Option	Default	Usage
			<ul style="list-style-type: none"> Parameter 1-70 PM Start Mode. Parameter 1-72 Start Function. Parameter 1-73 Flying Start. Parameter 1-80 Function at Stop. Parameter 1-82 Min Speed for Function at Stop [Hz]. Parameter 1-90 Motor Thermal Protection. Parameter 2-00 DC Hold/Motor Preheat Current. Parameter 2-01 DC Brake Current. Parameter 2-02 DC Braking Time. Parameter 2-04 DC Brake Cut In Speed. Parameter 2-10 Brake Function. Parameter 4-14 Motor Speed High Limit [Hz]. Parameter 4-19 Max Output Frequency. Parameter 4-58 Missing Motor Phase Function. Parameter 14-65 Speed Derate Dead Time Compensation.
Parameter 1-20 Motor Power	0.18–110 kW/0.25–150 hp	Size related	Enter the motor power from the nameplate data.
Parameter 1-22 Motor Voltage	50–1000 V	Size related	Enter the motor voltage from the nameplate data.
Parameter 1-23 Motor Frequency	20–400 Hz	Size related	Enter the motor frequency from the nameplate data.
Parameter 1-24 Motor Current	0.01–1000.00 A	Size related	Enter the motor current from the nameplate data.
Parameter 1-25 Motor Nominal Speed	50–9999 RPM	Size related	Enter the motor nominal speed from the nameplate data.
Parameter 1-26 Motor Cont. Rated Torque	0.1–1000.0 Nm	Size related	<p>This parameter is available when <i>parameter 1-10 Motor Construction</i> is set to options that enable permanent motor mode.</p> <div style="border: 1px solid black; padding: 5px; margin-top: 10px;"> <p style="text-align: center; font-weight: bold; letter-spacing: 0.5em;">N O T I C E</p> <p>Changing this parameter affects the settings of other parameters.</p> </div>
Parameter 1-29 Automatic Motor Adaption (AMA)	See <i>parameter 1-29 Automatic Motor Adaption (AMA)</i> .	Off	Performing an AMA optimizes motor performance.
Parameter 1-30 Stator Resistance (Rs)	0.000–99.990 Ω	Size related	Set the stator resistance value.
Parameter 1-37 d-axis Inductance (Ld)	0.000–1000.000 mH	Size related	Enter the value of the d-axis inductance. Obtain the value from the permanent magnet motor datasheet.

Parameter	Option	Default	Usage
<i>Parameter 1-38 q-axis Induc- tance (Lq)</i>	0.000–1000.000 mH	Size related	Enter the value of the q-axis inductance.
<i>Parameter 1-39 Motor Poles</i>	2–100	4	Enter the number of motor poles.
<i>Parameter 1-40 Back EMF at 1000 RPM</i>	10–9000 V	Size related	Line-line RMS back EMF voltage at 1000 RPM.
<i>Parameter 1-42 Motor Cable Length</i>	0–100 m	50 m	Enter the motor cable length.
<i>Parameter 1-44 d-axis Induc- tance Sat. (LdSat)</i>	0.000–1000.000 mH	Size related	This parameter corresponds to the inductance saturation of Ld. Ideally, this parameter has the same value as <i>parameter 1-37 d-axis Inductance (Ld)</i> . However, if the motor supplier provides an induction curve, enter the induction value, which is 200% of the nominal current.
<i>Parameter 1-45 q-axis Induc- tance Sat. (LqSat)</i>	0.000–1000.000 mH	Size related	This parameter corresponds to the inductance saturation of Lq. Ideally, this parameter has the same value as <i>parameter 1-38 q-axis Inductance (Lq)</i> . However, if the motor supplier provides an induction curve, enter the induction value, which is 200% of the nominal current.
<i>Parameter 1-46 Position Detec- tion Gain</i>	20–200%	100%	Adjusts the height of the test pulse during position detec- tion at start.
<i>Parameter 1-48 Current at Min Inductance for d-axis</i>	20–200%	100%	Enter the inductance saturation point.
<i>Parameter 1-49 Current at Min Inductance for q-axis</i>	20–200%	100%	This parameter specifies the saturation curve of the d- and q- inductance values. From 20–100% of this parameter, the in- ductances are linearly approximated due to <i>parameter 1-37 d-axis Inductance (Ld)</i> , <i>parameter 1-38 q-axis Inductance (Lq)</i> , <i>parameter 1-44 d-axis Inductance Sat. (LdSat)</i> , and <i>parameter 1-45 q-axis Inductance Sat. (LqSat)</i> .
<i>Parameter 1-70 PM Start Mode</i>	[0] Rotor Detection [1] Parking [3] Rotor Last Position	[1] Parking	Select the PM motor start mode.
<i>Parameter 1-73 Flying Start</i>	[0] Disabled [1] Enabled	[0] Disabled	Select [1] Enabled to enable the drive to catch a motor spin- ning due to mains drop-out. Select [0] Disabled if this func- tion is not required. When this parameter is set to [1] Ena- bled, <i>parameter 1-71 Start Delay</i> and <i>parameter 1-72 Start Function</i> are not functional. <i>Parameter 1-73 Flying Start</i> is ac- tive in VVC ⁺ mode only.
<i>Parameter 3-02 Minimum Refer- ence</i>	-4999.000–4999.000	0	The minimum reference is the lowest value obtainable by summing all references.
<i>Parameter 3-03 Maximum Ref- erence</i>	-4999.000–4999.000	50	The maximum reference is the lowest obtainable by sum- ming all references.

Parameter	Option	Default	Usage
<i>Parameter 3-41 Ramp 1 Ramp Up Time</i>	0.01–3600.00 s	Size related	If asynchronous motor is selected, the ramp-up time is from 0 to rated <i>parameter 1-23 Motor Frequency</i> . If PM motor is selected, the ramp-up time is from 0 to <i>parameter 1-25 Motor Nominal Speed</i> .
<i>Parameter 3-42 Ramp 1 Ramp Down Time</i>	0.01–3600.00 s	Size related	For asynchronous motors, the ramp-down time is from rated <i>parameter 1-23 Motor Frequency</i> to 0. For PM motors, the ramp-down time is from <i>parameter 1-25 Motor Nominal Speed</i> to 0.
<i>Parameter 4-12 Motor Speed Low Limit [Hz]</i>	0.0–400.0 Hz	0 Hz	Enter the minimum limit for low speed.
<i>Parameter 4-14 Motor Speed High Limit [Hz]</i>	0.0–400.0 Hz	100 Hz	Enter the maximum limit for high speed.
<i>Parameter 4-19 Max Output Frequency</i>	0.0–400.0 Hz	100 Hz	Enter the maximum output frequency value. If <i>parameter 4-19 Max Output Frequency</i> is set lower than <i>parameter 4-14 Motor Speed High Limit [Hz]</i> , <i>parameter 4-14 Motor Speed High Limit [Hz]</i> is set equal to <i>parameter 4-19 Max Output Frequency</i> automatically.
<i>Parameter 5-40 Function Relay</i>	See <i>parameter 5-40 Function Relay</i> .	[9] Alarm	Select the function to control output relay 1.
<i>Parameter 5-40 Function Relay</i>	See <i>parameter 5-40 Function Relay</i> .	[5] Drive running	Select the function to control output relay 2.
<i>Parameter 6-10 Terminal 53 Low Voltage</i>	0.00–10.00 V	0.07 V	Enter the voltage that corresponds to the low reference value.
<i>Parameter 6-11 Terminal 53 High Voltage</i>	0.00–10.00 V	10 V	Enter the voltage that corresponds to the high reference value.
<i>Parameter 6-12 Terminal 53 Low Current</i>	0.00–20.00 mA	4 mA	Enter the current that corresponds to the low reference value.
<i>Parameter 6-13 Terminal 53 High Current</i>	0.00–20.00 mA	20 mA	Enter the current that corresponds to the high reference value.
<i>Parameter 6-19 Terminal 53 mode</i>	[0] Current [1] Voltage	[1] Voltage	Select if terminal 53 is used for current or voltage input.
<i>Parameter 30-22 Locked Rotor Detection</i>	[0] Off [1] On	[0] Off	–
<i>Parameter 30-23 Locked Rotor Detection Time [s]</i>	0.05–1 s	0.10 s	–

7.2.2.4 Setup Wizard for Closed-loop Applications

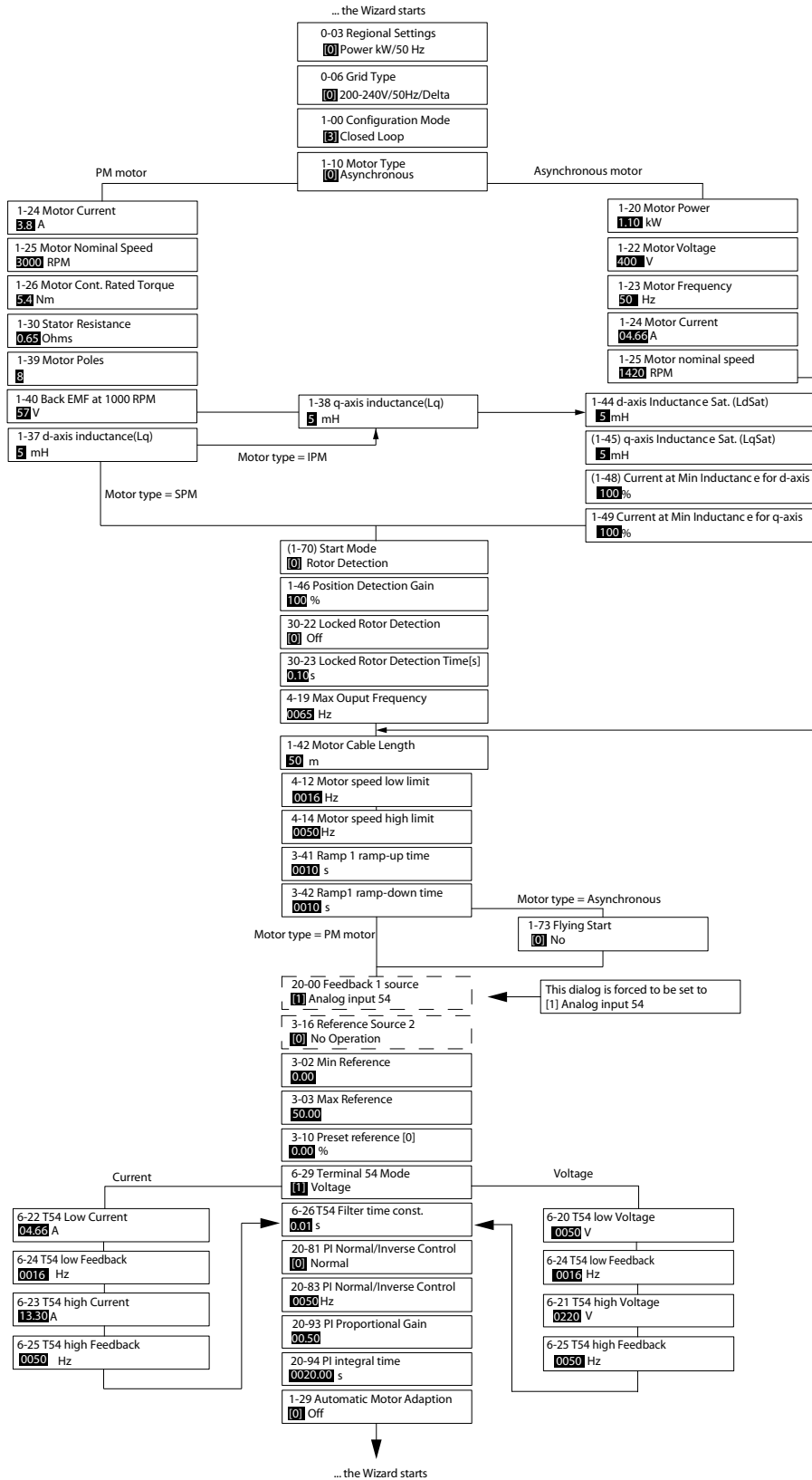

e30bc402.15

Illustration 62: Setup Wizard for Closed-loop Applications

Table 47: Setup Wizard for Closed-loop Applications

Parameter	Range	Default	Usage
<i>Parameter 0-03 Regional Set- tings</i>	[0] International [1] US	<i>[0] Interna- tional</i>	–
<i>Parameter 0-06 GridType</i>	[10] 380–440 V/50 Hz/IT-grid [11] 380–440 V/50 Hz/Delta [12] 380–440 V/50 Hz [20] 440–480 V/50 Hz/IT-grid [21] 440–480 V/50 Hz/Delta [22] 440–480 V/50 Hz [110] 380–440 V/60 Hz/IT-grid [111] 380–440 V/60 Hz/Delta [112] 380–440 V/60 Hz [120] 440–480 V/60 Hz/IT-grid [121] 440–480 V/60 Hz/Delta [122] 440–480 V/60 Hz	Size selected	Select the operating mode for restart after reconnection of the drive to mains voltage after power down.
<i>Parameter 1-00 Configuration Mode</i>	[0] Open loop [3] Closed loop	<i>[0] Open loop</i>	Select <i>[3] Closed loop</i> .
<i>Parameter 1-10 Motor Con- struction</i>	*[0] Asynchron [1] PM, non-salient SPM [3] PM, salient IPM	<i>[0] Asynchron</i>	Setting the parameter value might change these parameters: <ul style="list-style-type: none"> • <i>Parameter 1-01 Motor Control Principle.</i> • <i>Parameter 1-03 Torque Characteristics.</i> • <i>Parameter 1-08 Motor Control Bandwidth.</i> • <i>Parameter 1-14 Damping Gain.</i> • <i>Parameter 1-15 Low Speed Filter Time Const.</i> • <i>Parameter 1-16 High Speed Filter Time Const.</i> • <i>Parameter 1-17 Voltage Filter Time Const.</i> • <i>Parameter 1-20 Motor Power.</i> • <i>Parameter 1-22 Motor Voltage.</i> • <i>Parameter 1-23 Motor Frequency.</i> • <i>Parameter 1-24 Motor Current.</i> • <i>Parameter 1-25 Motor Nominal Speed.</i> • <i>Parameter 1-26 Motor Cont. Rated Torque.</i> • <i>Parameter 1-30 Stator Resistance (Rs).</i> • <i>Parameter 1-33 Stator Leakage Reactance (X1).</i> • <i>Parameter 1-35 Main Reactance (Xh).</i> • <i>Parameter 1-37 d-axis Inductance (Ld).</i> • <i>Parameter 1-38 q-axis Inductance (Lq).</i> • <i>Parameter 1-39 Motor Poles.</i> • <i>Parameter 1-40 Back EMF at 1000 RPM.</i> • <i>Parameter 1-44 d-axis Inductance Sat. (LdSat).</i> • <i>Parameter 1-45 q-axis Inductance Sat. (LqSat).</i> • <i>Parameter 1-46 Position Detection Gain.</i>

Parameter	Range	Default	Usage
			<ul style="list-style-type: none"> Parameter 1-48 Current at Min Inductance for d-axis. Parameter 1-49 Current at Min Inductance for q-axis. Parameter 1-66 Min. Current at Low Speed. Parameter 1-70 PM Start Mode. Parameter 1-72 Start Function. Parameter 1-73 Flying Start. Parameter 1-80 Function at Stop. Parameter 1-82 Min Speed for Function at Stop [Hz]. Parameter 1-90 Motor Thermal Protection. Parameter 2-00 DC Hold/Motor Preheat Current. Parameter 2-01 DC Brake Current. Parameter 2-02 DC Braking Time. Parameter 2-04 DC Brake Cut In Speed. Parameter 2-10 Brake Function. Parameter 4-14 Motor Speed High Limit [Hz]. Parameter 4-19 Max Output Frequency. Parameter 4-58 Missing Motor Phase Function. Parameter 14-65 Speed Derate Dead Time Compensation.
Parameter 1-20 Motor Power	0.18–110 kW/0.25–150 hp	Size related	Enter the motor power from the nameplate data.
Parameter 1-22 Motor Voltage	50–1000 V	Size related	Enter the motor voltage from the nameplate data.
Parameter 1-23 Motor Frequency	20–400 Hz	Size related	Enter the motor frequency from the nameplate data.
Parameter 1-24 Motor Current	0.01–1000.00 A	Size related	Enter the motor current from the nameplate data.
Parameter 1-25 Motor Nominal Speed	50–60000 RPM	Size related	Enter the motor nominal speed from the nameplate data.
Parameter 1-26 Motor Cont. Rated Torque	0.1–10000.0 Nm	Size related	<p>This parameter is available when <i>parameter 1-10 Motor Construction</i> is set to options that enable permanent motor mode.</p> <div style="border: 1px solid black; padding: 5px; text-align: center;"> <p>NOTICE</p> <p>Changing this parameter affects the settings of other parameters.</p> </div>
Parameter 1-29 Automatic Motor Adaption (AMA)	–	Off	Performing an AMA optimizes motor performance.
Parameter 1-30 Stator Resistance (Rs)	0.000–9999.000 Ω	Size related	Set the stator resistance value.

Parameter	Range	Default	Usage
<i>Parameter 1-37 d-axis Inductance (Ld)</i>	0.000–1000.000 mH	Size related	Enter the value of the d-axis inductance. Obtain the value from the permanent magnet motor datasheet.
<i>Parameter 1-38 q-axis Inductance (Lq)</i>	0.000–1000.000 mH	Size related	Enter the value of the q-axis inductance.
<i>Parameter 1-39 Motor Poles</i>	2–100	4	Enter the number of motor poles.
<i>Parameter 1-40 Back EMF at 1000 RPM</i>	10–9000 V	Size related	Line-line RMS back EMF voltage at 1000 RPM.
<i>Parameter 1-42 Motor Cable Length</i>	0–100 m	50 m	Enter the motor cable length.
<i>Parameter 1-44 d-axis Inductance Sat. (LdSat)</i>	0.000–1000.000 mH	Size related	This parameter corresponds to the inductance saturation of Ld. Ideally, this parameter has the same value as <i>parameter 1-37 d-axis Inductance (Ld)</i> . However, if the motor supplier provides an induction curve, enter the induction value, which is 200% of the nominal current.
<i>Parameter 1-45 q-axis Inductance Sat. (LqSat)</i>	0.000–1000.000 mH	Size related	This parameter corresponds to the inductance saturation of Lq. Ideally, this parameter has the same value as <i>parameter 1-38 q-axis Inductance (Lq)</i> . However, if the motor supplier provides an induction curve, enter the induction value, which is 200% of the nominal current.
<i>Parameter 1-46 Position Detection Gain</i>	20–200%	100%	Adjusts the height of the test pulse during position detection at start.
<i>Parameter 1-48 Current at Min Inductance for d-axis</i>	20–200%	100%	Enter the inductance saturation point.
<i>Parameter 1-49 Current at Min Inductance for q-axis</i>	20–200%	100%	This parameter specifies the saturation curve of the d- and q-inductance values. From 20–100% of this parameter, the inductances are linearly approximated due to <i>parameter 1-37 d-axis Inductance (Ld)</i> , <i>parameter 1-38 q-axis Inductance (Lq)</i> , <i>parameter 1-44 d-axis Inductance Sat. (LdSat)</i> , and <i>parameter 1-45 q-axis Inductance Sat. (LqSat)</i> .
<i>Parameter 1-70 PM Start Mode</i>	[0] Rotor Detection [1] Parking [3] Rotor Last Position	[1] Parking	Select the PM motor start mode.
<i>Parameter 1-73 Flying Start</i>	[0] Disabled [1] Enabled	[0] Disabled	Select [1] Enabled to enable the drive to catch a spinning motor in, for example, fan applications. When PM is selected, this parameter is enabled.
<i>Parameter 3-02 Minimum Reference</i>	-4999.000–4999.000	0	The minimum reference is the lowest value obtainable by summing all references.

Parameter	Range	Default	Usage
<i>Parameter 3-03 Maximum Reference</i>	-4999.000–4999.000	50	The maximum reference is the highest value obtainable by summing all references.
<i>Parameter 3-10 Preset Reference</i>	-100–100%	0	Enter the setpoint.
<i>Parameter 3-41 Ramp 1 Ramp Up Time</i>	0.05–3600.0 s	Size related	Ramp-up time from 0 to rated <i>parameter 1-23 Motor Frequency</i> for asynchronous motors. Ramp-up time from 0 to <i>parameter 1-25 Motor Nominal Speed</i> for PM motors.
<i>Parameter 3-42 Ramp 1 Ramp Down Time</i>	0.05–3600.0 s	Size related	Ramp-down time from rated <i>parameter 1-23 Motor Frequency</i> to 0 for asynchronous motors. Ramp-down time from <i>parameter 1-25 Motor Nominal Speed</i> to 0 for PM motors.
<i>Parameter 4-12 Motor Speed Low Limit [Hz]</i>	0.0–400.0 Hz	0.0 Hz	Enter the minimum limit for low speed.
<i>Parameter 4-14 Motor Speed High Limit [Hz]</i>	0.0–400.0 Hz	100 Hz	Enter the minimum limit for high speed.
<i>Parameter 4-19 Max Output Frequency</i>	0.0–400.0 Hz	100 Hz	Enter the maximum output frequency value. If <i>parameter 4-19 Max Output Frequency</i> is set lower than <i>parameter 4-14 Motor Speed High Limit [Hz]</i> , <i>parameter 4-14 Motor Speed High Limit [Hz]</i> is set equal to <i>parameter 4-19 Max Output Frequency</i> automatically.
<i>Parameter 6-20 Terminal 54 Low Voltage</i>	0.00–10.00 V	0.07 V	Enter the voltage that corresponds to the low reference value.
<i>Parameter 6-21 Terminal 54 High Voltage</i>	0.00–10.00 V	10.00 V	Enter the voltage that corresponds to the high reference value.
<i>Parameter 6-22 Terminal 54 Low Current</i>	0.00–20.00 mA	4.00 mA	Enter the current that corresponds to the low reference value.
<i>Parameter 6-23 Terminal 54 High Current</i>	0.00–20.00 mA	20.00 mA	Enter the current that corresponds to the high reference value.
<i>Parameter 6-24 Terminal 54 Low Ref./Feedb. Value</i>	-4999–4999	0	Enter the feedback value that corresponds to the voltage or current set in <i>parameter 6-20 Terminal 54 Low Voltage/parameter 6-22 Terminal 54 Low Current</i> .
<i>Parameter 6-25 Terminal 54 High Ref./Feedb. Value</i>	-4999–4999	50	Enter the feedback value that corresponds to the voltage or current set in <i>parameter 6-21 Terminal 54 High Voltage/parameter 6-23 Terminal 54 High Current</i> .
<i>Parameter 6-26 Terminal 54 Filter Time Constant</i>	0.00–10.00 s	0.01	Enter the filter time constant.

Parameter	Range	Default	Usage
<i>Parameter 6-29 Terminal 54 mode</i>	[0] Current [1] Voltage	[1] Voltage	Select if terminal 54 is used for current or voltage input.
<i>Parameter 20-81 PI Normal/Inverse Control</i>	[0] Normal [1] Inverse	[0] Normal	Select [0] Normal to set the process control to increase the output speed when the process error is positive. Select [1] Inverse to reduce the output speed.
<i>Parameter 20-83 PI Start Speed [Hz]</i>	0–200 Hz	0 Hz	Enter the motor speed to be attained as a start signal for commencement of PI control.
<i>Parameter 20-93 PI Proportional Gain</i>	0.00–10.00	0.01	Enter the process controller proportional gain. Quick control is obtained at high amplification. However, if amplification is too high, the process may become unstable.
<i>Parameter 20-94 PI Integral Time</i>	0.1–999.0 s	999.0 s	Enter the process controller integral time. Obtain quick control through a short integral time, though if the integral time is too short, the process becomes unstable. An excessively long integral time disables the integral action.
<i>Parameter 30-22 Locked Rotor Detection</i>	[0] Off [1] On	[0] Off	–
<i>Parameter 30-23 Locked Rotor Detection Time [s]</i>	0.05–1.00 s	0.10 s	–

7.2.2.5 Motor Setup

The motor setup wizard guides users through the needed motor parameters.

Table 48: Motor Setup Wizard Settings

Parameter	Range	Default	Usage
<i>Parameter 0-03 Regional Settings</i>	[0] International [1] US	[0] International	–
<i>Parameter 0-06 GridType</i>	[10] 380–440 V/50 Hz/IT-grid [11] 380–440 V/50 Hz/Delta [12] 380–440 V/50 Hz [20] 440–480 V/50 Hz/IT-grid [21] 440–480 V/50 Hz/Delta [22] 440–480 V/50 Hz [110] 380–440 V/60 Hz/IT-grid [111] 380–440 V/60 Hz/Delta [112] 380–440 V/60 Hz [120] 440–480 V/60 Hz/IT-grid [121] 440–480 V/60 Hz/Delta [122] 440–480 V/60 Hz	Size selected	Select the operating mode for restart after reconnection of the drive to mains voltage after power down.
<i>Parameter 1-10 Motor Construction</i>	*[0] Asynchron [1] PM, non-salient SPM [3] PM, salient IPM	[0] Asynchron	Setting the parameter value might change these parameters:

Parameter	Range	Default	Usage
			<ul style="list-style-type: none"> • <i>Parameter 1-01 Motor Control Principle.</i> • <i>Parameter 1-03 Torque Characteristics.</i> • <i>Parameter 1-08 Motor Control Bandwidth.</i> • <i>Parameter 1-14 Damping Gain.</i> • <i>Parameter 1-15 Low Speed Filter Time Const.</i> • <i>Parameter 1-16 High Speed Filter Time Const.</i> • <i>Parameter 1-17 Voltage Filter Time Const.</i> • <i>Parameter 1-20 Motor Power.</i> • <i>Parameter 1-22 Motor Voltage.</i> • <i>Parameter 1-23 Motor Frequency.</i> • <i>Parameter 1-24 Motor Current.</i> • <i>Parameter 1-25 Motor Nominal Speed.</i> • <i>Parameter 1-26 Motor Cont. Rated Torque.</i> • <i>Parameter 1-30 Stator Resistance (Rs).</i> • <i>Parameter 1-33 Stator Leakage Reactance (X1).</i> • <i>Parameter 1-35 Main Reactance (Xh).</i> • <i>Parameter 1-37 d-axis Inductance (Ld).</i> • <i>Parameter 1-38 q-axis Inductance (Lq).</i> • <i>Parameter 1-39 Motor Poles.</i> • <i>Parameter 1-40 Back EMF at 1000 RPM.</i> • <i>Parameter 1-44 d-axis Inductance Sat. (LdSat).</i> • <i>Parameter 1-45 q-axis Inductance Sat. (LqSat).</i> • <i>Parameter 1-46 Position Detection Gain.</i> • <i>Parameter 1-48 Current at Min Inductance for d-axis.</i> • <i>Parameter 1-49 Current at Min Inductance for q-axis.</i> • <i>Parameter 1-66 Min. Current at Low Speed.</i> • <i>Parameter 1-70 PM Start Mode.</i> • <i>Parameter 1-72 Start Function.</i> • <i>Parameter 1-73 Flying Start.</i> • <i>Parameter 1-80 Function at Stop.</i> • <i>Parameter 1-82 Min Speed for Function at Stop [Hz].</i> • <i>Parameter 1-90 Motor Thermal Protection.</i> • <i>Parameter 2-00 DC Hold/Motor Preheat Current.</i> • <i>Parameter 2-01 DC Brake Current.</i> • <i>Parameter 2-02 DC Braking Time.</i> • <i>Parameter 2-04 DC Brake Cut In Speed.</i> • <i>Parameter 2-10 Brake Function.</i> • <i>Parameter 4-14 Motor Speed High Limit [Hz].</i> • <i>Parameter 4-19 Max Output Frequency.</i> • <i>Parameter 4-58 Missing Motor Phase Function.</i> • <i>Parameter 14-65 Speed Derate Dead Time Compensation.</i>

Parameter	Range	Default	Usage
<i>Parameter 1-20 Motor Power</i>	0.18–110 kW/0.25–150 hp	Size related	Enter the motor power from the nameplate data.
<i>Parameter 1-22 Motor Voltage</i>	50–1000 V	Size related	Enter the motor voltage from the nameplate data.
<i>Parameter 1-23 Motor Frequency</i>	20–400 Hz	Size related	Enter the motor frequency from the nameplate data.
<i>Parameter 1-24 Motor Current</i>	0.01–10000.00 A	Size related	Enter the motor current from the nameplate data.
<i>Parameter 1-25 Motor Nominal Speed</i>	50–9999 RPM	Size related	Enter the motor nominal speed from the nameplate data.
<i>Parameter 1-26 Motor Cont. Rated Torque</i>	0.1–1000.0 Nm	Size related	This parameter is available when <i>parameter 1-10 Motor Construction</i> is set to options that enable permanent motor mode. <div style="background-color: #cccccc; text-align: center; padding: 5px;">NOTICE</div> Changing this parameter affects the settings of other parameters.
<i>Parameter 1-30 Stator Resistance (Rs)</i>	0–99.990 Ω	Size related	Set the stator resistance value.
<i>Parameter 1-37 d-axis Inductance (Ld)</i>	0.000–1000.000 mH	Size related	Enter the value of the d-axis inductance. Obtain the value from the permanent magnet motor datasheet.
<i>Parameter 1-38 q-axis Inductance (Lq)</i>	0.000–1000.000 mH	Size related	Enter the value of the q-axis inductance.
<i>Parameter 1-39 Motor Poles</i>	2–100	4	Enter the number of motor poles.
<i>Parameter 1-40 Back EMF at 1000 RPM</i>	10–9000 V	Size related	Line-line RMS back EMF voltage at 1000 RPM.
<i>Parameter 1-42 Motor Cable Length</i>	0–100 m	50 m	Enter the motor cable length.
<i>Parameter 1-44 d-axis Inductance Sat. (LdSat)</i>	0.000–1000.000 mH	Size related	This parameter corresponds to the inductance saturation of Ld. Ideally, this parameter has the same value as <i>parameter 1-37 d-axis Inductance (Ld)</i> . However, if the motor supplier provides an induction curve, enter the induction value, which is 200% of the nominal current.
<i>Parameter 1-45 q-axis Inductance Sat. (LqSat)</i>	0.000–1000.000 mH	Size related	This parameter corresponds to the inductance saturation of Lq. Ideally, this parameter has the same value as <i>parameter 1-38 q-axis Inductance (Lq)</i> . However, if the motor supplier provides an induction curve, enter the induction value, which is 200% of the nominal current.

Parameter	Range	Default	Usage
<i>Parameter 1-46 Position Detection Gain</i>	20–200%	100%	Adjusts the height of the test pulse during position detection at start.
<i>Parameter 1-48 Current at Min Inductance for d-axis</i>	20–200%	100%	Enter the inductance saturation point.
<i>Parameter 1-49 Current at Min Inductance for q-axis</i>	20–200%	100%	This parameter specifies the saturation curve of the d- and q-inductance values. From 20–100% of this parameter, the inductances are linearly approximated due to <i>parameter 1-37 d-axis Inductance (Ld)</i> , <i>parameter 1-38 q-axis Inductance (Lq)</i> , <i>parameter 1-44 d-axis Inductance Sat. (LdSat)</i> , and <i>parameter 1-45 q-axis Inductance Sat. (LqSat)</i> .
<i>Parameter 1-70 PM Start Mode</i>	[0] Rotor Detection [1] Parking [3] Rotor Last Position	[1] Parking	Select the PM motor start mode.
<i>Parameter 1-73 Flying Start</i>	[0] Disabled [1] Enabled	[0] Disabled	Select [1] Enabled to enable the drive to catch a spinning motor.
<i>Parameter 3-41 Ramp 1 Ramp Up Time</i>	0.05–3600.0 s	Size related	Ramp-up time from 0 to rated <i>parameter 1-23 Motor Frequency</i> .
<i>Parameter 3-42 Ramp 1 Ramp Down Time</i>	0.05–3600.0 s	Size related	Ramp-down time from rated <i>parameter 1-23 Motor Frequency</i> to 0.
<i>Parameter 4-12 Motor Speed Low Limit [Hz]</i>	0.0–400.0 Hz	0.0 Hz	Enter the minimum limit for low speed.
<i>Parameter 4-14 Motor Speed High Limit [Hz]</i>	0.0–400.0 Hz	100.0 Hz	Enter the maximum limit for high speed.
<i>Parameter 4-19 Max Output Frequency</i>	0.0–400.0 Hz	100.0 Hz	Enter the maximum output frequency value. If <i>parameter 4-19 Max Output Frequency</i> is set lower than <i>parameter 4-14 Motor Speed High Limit [Hz]</i> , <i>parameter 4-14 Motor Speed High Limit [Hz]</i> is set equal to <i>parameter 4-19 Max Output Frequency</i> automatically.
<i>Parameter 30-22 Locked Rotor Detection</i>	[0] Off [1] On	[0] Off	–
<i>Parameter 30-23 Locked Rotor Detection Time [s]</i>	0.05–1.00 s	0.10 s	–

7.2.2.6 Changes Made Function

The changes made function lists all parameters changed from default settings.

- The list shows only parameters that have been changed in the current edit setup.
- Parameters that have been reset to default values are not listed.
- The message *Empty* indicates that no parameters have been changed.

7.2.2.7 Changing Parameter Settings

Procedure

1. To enter the Quick Menu, press the [Menu] key until the indicator in the display is placed above Quick Menu.
2. Press [▲] [▼] to select the wizard, closed-loop setup, motor setup, or changes made.
3. Press [OK].
4. Press [▲] [▼] to browse through the parameters in the Quick Menu.
5. Press [OK] to select a parameter.
6. Press [▲] [▼] to change the value of a parameter setting.
7. Press [OK] to accept the change.
8. Press either [Back] twice to enter Status, or press [Menu] once to enter the Main Menu.

7.2.2.8 Accessing All Parameters via the Main Menu

Procedure

1. Press the [Menu] key until the indicator in the display is placed above Main Menu.
2. Press [▲] [▼] to browse through the parameter groups.
3. Press [OK] to select a parameter group.
4. Press [▲] [▼] to browse through the parameters in the specific group.
5. Press [OK] to select the parameter.
6. Press [▲] [▼] to set/change the parameter value.
7. Press [OK] to accept the change.

7.2.3 Main Menu

Press [Menu] to access the main menu and program all parameters. The main menu parameters can be accessed readily unless a password has been created via *parameter 0-60 Main Menu Password*.

For most applications, it is not necessary to access the main menu parameters. The quick menu provides the simplest and quickest access to the typical required parameters.

7.3 Quick Transfer of Parameter Settings between Multiple Drives

When the set-up of a drive is completed, store the data in the LCP. Then connect the LCP to another drive and copy the parameter settings to the new drive.

7.3.1 Transferring Data from the Drive to the LCP

Procedure

1. Go to *parameter 0-50 LCP Copy*.
2. Press [OK].
3. Select [1] All to LCP.
4. Press [OK].

7.3.2 Transferring Data from the LCP to the Drive

Procedure

1. Go to *parameter 0-50 LCP Copy*.
2. Press [OK].
3. Select [2] All from LCP.
4. Press [OK].

7.4 Readout and Programming of Indexed Parameters

Procedure

1. Select the parameter and press [OK].
2. Press [▲]/[▼] to scroll through the indexed values.
3. To change the parameter value, select the indexed value and press [OK].
4. Change the value by pressing [▲]/[▼].
5. Press [OK] or [Cancel] to accept or abort the new setting.
6. Press [Back] to leave the parameter.

7.5 Initialization to Default Settings

There are 2 ways to initialize the drive to the default settings.

- Recommended initialization
- Two-finger initialization

Initialization of parameters is confirmed by *alarm 80, Drive initialised* in the display after the power cycle.

7.5.1 Recommended Initialization

Procedure

1. Select *parameter 14-22 Operation Mode*.
2. Press [OK].
3. Select *[2] Initialisation* and press [OK].
4. Power off the drive and wait until the display turns off.
5. Reconnect the mains supply. The drive is now reset, except for the following parameters.

- *Parameter 1-06 Clockwise Direction*
- *Parameter 8-30 Protocol*
- *Parameter 8-31 Address*
- *Parameter 8-32 Baud Rate*
- *Parameter 8-33 Parity / Stop Bits*
- *Parameter 8-35 Minimum Response Delay*
- *Parameter 8-36 Maximum Response Delay*
- *Parameter 8-37 Maximum Inter-char delay*
- *Parameter 8-70 BACnet Device Instance*
- *Parameter 8-72 MS/TP Max Masters*
- *Parameter 8-73 MS/TP Max Info Frames*
- *Parameter 8-74 "I am" Service*
- *Parameter 8-75 Initialisation Password*
- *Parameter 15-00 Operating hours to parameter 15-05 Over Volt's*
- *Parameter 15-03 Power Up's*
- *Parameter 15-04 Over Temp's*
- *Parameter 15-05 Over Volt's*
- *Parameter 15-30 Alarm Log: Error Code*
- *Parameter group 15-4* Drive identification*
- *Parameter 18-10 FireMode Log:Event*

7.5.2 Two-finger Initialization

Procedure

1. Power off the drive.

2. Press [OK] and [Menu].
3. Power up the drive while still pressing the keys for 10 s.
4. The drive is now reset, except for the following parameters.

- *Parameter 1-06 Clockwise Direction*
- *Parameter 15-00 Operating hours*
- *Parameter 15-03 Power Up's*
- *Parameter 15-04 Over Temp's*
- *Parameter 15-05 Over Volt's*
- *Parameter group 15-4* Drive identification*
- *Parameter 18-10 FireMode Log:Event*

8 RS485 Installation and Set-up

8.1 RS485

8.1.1 Overview

RS485 is a 2-wire bus interface compatible with multi-drop network topology. The nodes can be connected as a bus, or via drop cables from a common trunk line. A total of 32 nodes can be connected to 1 network segment. Repeaters divide network segments, see the following illustration.

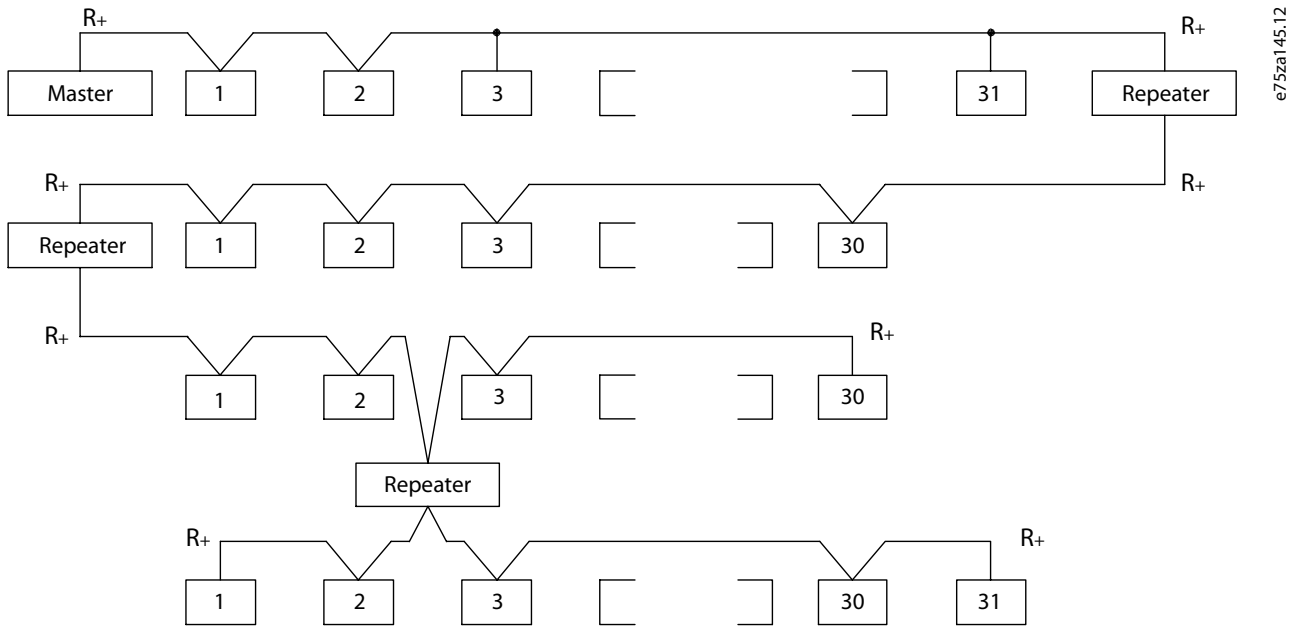

Illustration 63: RS485 Bus Interface

NOTICE

Each repeater functions as a node within the segment in which it is installed. Each node connected within a given network must have a unique node address across all segments.

Terminate each segment at both ends, using either the termination switch (S801) of the drives or a biased termination resistor network. Always use shielded twisted pair (STP) cable for bus cabling and follow good common installation practice.

Low-impedance ground connection of the shield at every node is important, including at high frequencies. Thus, connect a large surface of the shield to ground, for example with a cable clamp or a conductive cable gland. Sometimes, it is necessary to apply potential-equalizing cables to maintain the same ground potential throughout the network, particularly in installations with long cables.

To prevent impedance mismatch, use the same type of cable throughout the entire network. When connecting a motor to the drive, always use shielded motor cable.

Table 49: Cable Specifications

Cable	Shielded twisted pair (STP)
Impedance [Ω]	120
Cable length [m (ft)]	Maximum 1200 (3937) (including drop lines). Maximum 500 (1640) station-to-station.

8.1.2 Connecting the Drive to the RS485 Network

Procedure

1. Connect signal wires to terminal 68 (P+) and terminal 69 (N-) on the main control board of the drive.

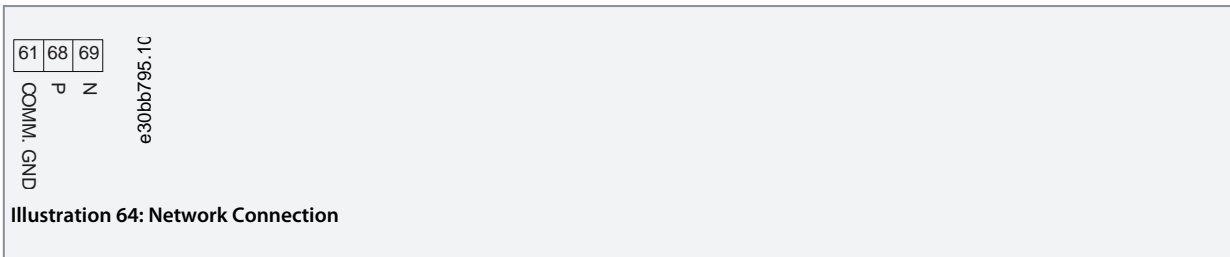

2. Connect the cable shield to the cable clamps.

NOTICE

To reduce noise between conductors, use shielded, twisted-pair cables.

8.1.3 Hardware Set-up

To terminate the RS485 bus, use the terminator switch on the main control board of the drive.

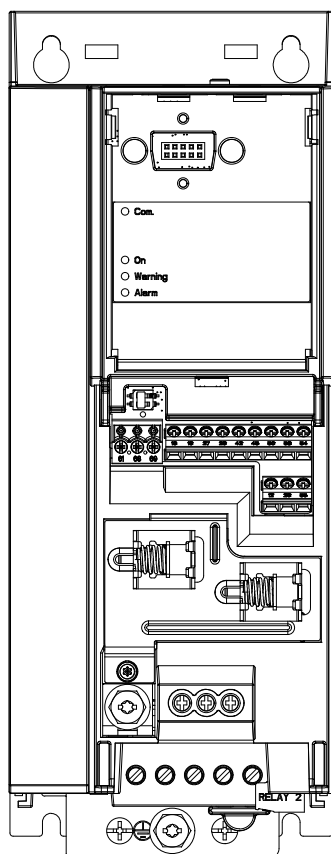

e30bg049.10

Illustration 65: Terminator Switch Factory Setting

The factory setting for the switch is OFF.

8.1.4 Parameter Settings for Modbus Communication

Table 50: Modbus Communication Parameter Settings

Parameter	Function
<i>Parameter 8-30 Protocol</i>	Select the application protocol to run for the RS485 interface.
<i>Parameter 8-31 Address</i>	Set the node address. <div style="text-align: center;">NOTICE</div> The address range depends on the protocol selected in <i>parameter 8-30 Protocol</i> .
<i>Parameter 8-32 Baud Rate</i>	Set the baud rate. <div style="text-align: center;">NOTICE</div> The default baud rate depends on the protocol selected in <i>parameter 8-30 Protocol</i> .
<i>Parameter 8-33 Parity / Stop Bits</i>	Set the parity and number of stop bits. <div style="text-align: center;">NOTICE</div> The default selection depends on the protocol selected in <i>parameter 8-30 Protocol</i> .
<i>Parameter 8-35 Minimum Response Delay</i>	Specify a minimum delay time between receiving a request and transmitting a response. This function is for overcoming modem turnaround delays.
<i>Parameter 8-36 Maximum Response Delay</i>	Specify a maximum delay time between transmitting a request and receiving a response.
<i>Parameter 8-37 Maximum Inter-char delay</i>	If transmission is interrupted, specify a maximum delay time between 2 received bytes to ensure timeout. <div style="text-align: center;">NOTICE</div> The default selection depends on the protocol selected in <i>parameter 8-30 Protocol</i> .

8.1.5 EMC Precautions

To achieve interference-free operation of the RS485 network, Danfoss recommends the following EMC precautions.

NOTICE

Observe relevant national and local regulations, for example regarding protective earth connection. Failure to ground the cables properly can result in communication degradation and equipment damage. To avoid coupling of high-frequency noise between the cables, keep the RS485 communication cable away from motor and brake resistor cables. Normally, a distance of 200 mm (8 in) is sufficient. Maintain the greatest possible distance between the cables, especially where cables run in parallel over long distances. When crossing is unavoidable, the RS485 cable must cross motor and brake resistor cables at an angle of 90°.

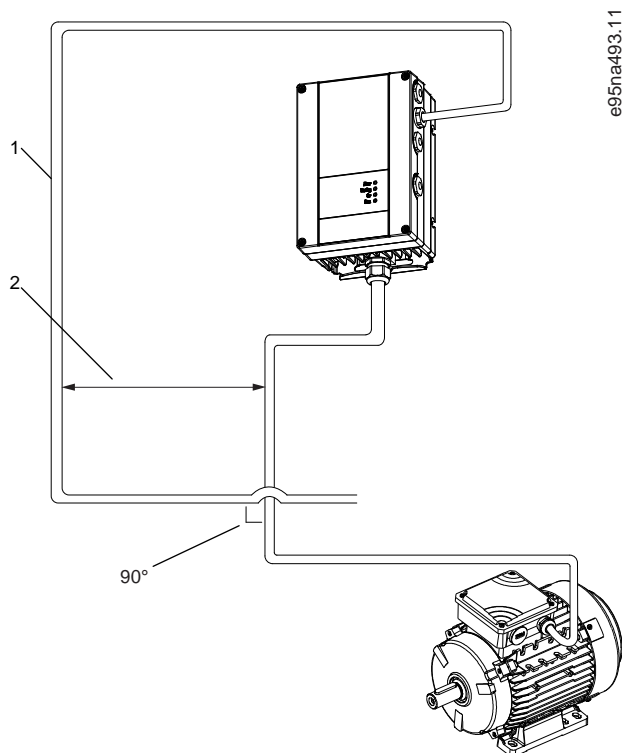

Illustration 66: Minimum Distance between Communication and Power Cables

1	Fieldbus cable
2	Minimum 200 mm (8 in) distance

8.2 FC Protocol

8.2.1 Overview

The FC protocol, also referred to as FC bus or standard bus, is the Danfoss standard fieldbus. It defines an access technique according to the master/follower principle for communications via a fieldbus.

One master and a maximum of 126 followers can be connected to the bus. The master selects the individual followers via an address character in the telegram. A follower itself can never transmit without first being requested to do so, and direct telegram transfer between the individual followers is not possible. Communications occur in the halfduplex mode.

The master function cannot be transferred to another node (single-master system).

The physical layer is RS485, thus utilizing the RS485 port built into the drive. The FC protocol supports different telegram formats:

- A short format of 8 bytes for process data.
- A long format of 16 bytes that also includes a parameter channel.
- A format used for texts.

8.2.2 FC with Modbus RTU

The FC protocol provides access to the control word and bus reference of the drive.

The control word allows the Modbus master to control several important functions of the drive:

- Start.
- Stop of the drive in various ways:
 - Coast stop.
 - Quick stop.
 - DC brake stop.
 - Normal (ramp) stop.
- Reset after a fault trip.

- Run at various preset speeds.
- Run in reverse.
- Change of the active set-up.
- Control of the 2 relays built into the drive.

The bus reference is commonly used for speed control. It is also possible to access the parameters, read their values, and where possible, write values to them. Accessing the parameters offers a range of control options, including controlling the setpoint of the drive when its internal PI controller is used.

8.3 Network Configuration

To enable the FC protocol for the drive, set the following parameters.

Table 51: Parameters to Enable the Protocol

Parameter	Setting
Parameter 8-30 Protocol	FC
Parameter 8-31 Address	1–126
Parameter 8-32 Baud Rate	2400–115200
Parameter 8-33 Parity/Stop Bits	Even parity, 1 stop bit (default)

8.4 FC Protocol Message Framing Structure

8.4.1 Content of a Character (byte)

Each character transferred begins with a start bit. Then 8 data bits are transferred, corresponding to a byte. Each character is secured via a parity bit. This bit is set at 1 when it reaches parity. Parity is when there are an equal number of 1s in the 8 data bits and the parity bit in total. A stop bit completes a character, consisting of 11 bits in all.

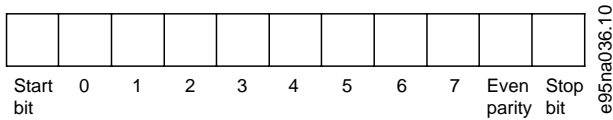

Illustration 67: Content of a Character

8.4.2 Telegram Structure

Each telegram has the following structure:

- Start character (STX) = 02 hex.
- A byte denoting the telegram length (LGE).
- A byte denoting the drive address (ADR).

Several data bytes (variable, depending on the type of telegram) follow.

A data control byte (BCC) completes the telegram.

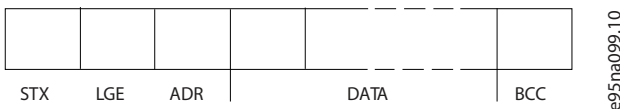

Illustration 68: Telegram Structure

8.4.3 Telegram Length (LGE)

The telegram length is the number of data bytes plus the address byte ADR and the data control byte BCC.

Table 52: Length of Telegrams

4 data bytes	LGE=4+1+1=6 bytes
--------------	-------------------

12 data bytes	LGE=12+1+1=14 bytes
Telegrams containing texts	10 ⁽¹⁾ +n bytes

¹ The 10 represents the fixed characters, while the n is variable (depending on the length of the text).

8.4.4 Drive Address (ADR)

Address format 1–126:

- Bit 7 = 1 (address format 1–126 active).
- Bit 0–6 = drive address 1–126.
- Bit 0–6 = 0 broadcast.

The follower returns the address byte unchanged to the master in the response telegram.

8.4.5 Data Control Byte (BCC)

The checksum is calculated as an XOR-function. Before the first byte in the telegram is received, the calculated checksum is 0.

8.4.6 The Data Field

The structure of data blocks depends on the type of telegram. There are 3 telegram types, and the type applies for both control telegrams (master->follower) and response telegrams (follower->master).

The 3 types of telegram are:

- Process block (PCD).
- Parameter block.
- Text block.

Process block (PCD)

The PCD is made up of a data block of 4 bytes (2 words) and contains:

- Control word and reference value (from master to follower).
- Status word and present output frequency (from follower to master).

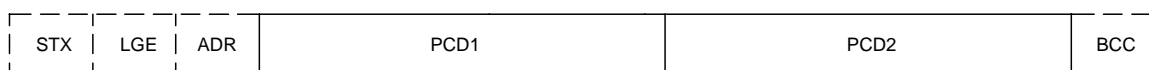

e30ba269.10

Illustration 69: Process Block

Parameter block

The parameter block is used to transfer parameters between master and follower. The data block is made up of 12 bytes (6 words) and also contains the process block.

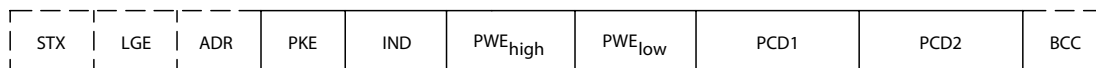

e30ba271.10

Illustration 70: Parameter Block

Text block

The text block is used to read or write texts via the data block.

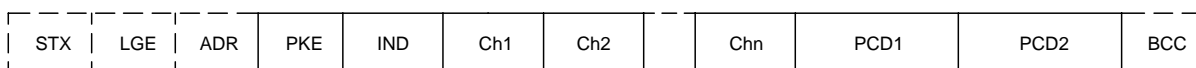

e30ba270.10

Illustration 71: Text Block

8.4.7 The PKE Field

The PKE field contains 2 subfields:

- Parameter command and response (AK)
- Parameter number (PNU)

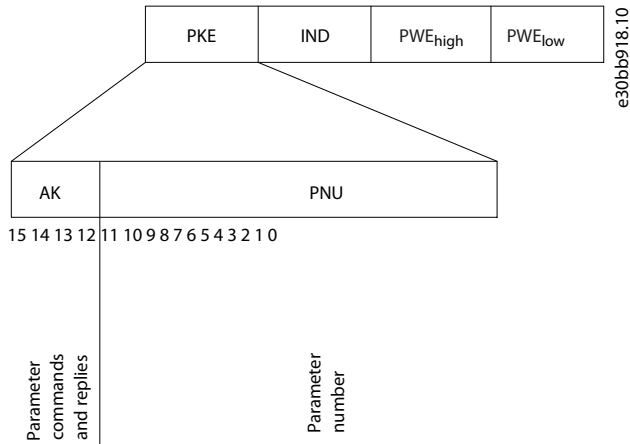

Illustration 72: PKE Field

Bits 12–15 transfer parameter commands from master to follower and return processed follower responses to the master.

Table 53: Parameter Commands

Parameter commands master->follower				
Bit number				Parameter command
15	14	13	12	
0	0	0	0	No command.
0	0	0	1	Read parameter value.
0	0	1	0	Write parameter value in RAM (word).
0	0	1	1	Write parameter value in RAM (double word).
1	1	0	1	Write parameter value in RAM and EEPROM (double word).
1	1	1	0	Write parameter value in RAM and EEPROM (word).
1	1	1	1	Read text.

Table 54: Response

Response follower->master				
Bit number				Response
15	14	13	12	
0	0	0	0	No response.
0	0	0	1	Parameter value transferred (word).
0	0	1	0	Parameter value transferred (double word).
0	1	1	1	Command cannot be performed.
1	1	1	1	Text transferred.

If the command cannot be performed, the follower sends *0111 Command cannot be performed* response and issues the following fault reports in the following table.

Table 55: Follower Report

Fault code	FC specification
0	Illegal parameter number.
1	Parameter cannot be changed
2	Upper or lower limit is exceeded.
3	Subindex is corrupted.
4	No array.
5	Wrong data type.
6	Not used.
7	Not used.
9	Description element is not available.
11	No parameter write access.
15	No text available.
17	Not applicable while running.
18	Other errors.
100	–
>100	–
130	No bus access for this parameter.
131	Write to factory set-up is not possible.
132	No LCP access.
252	Unknown viewer.
253	Request is not supported.
254	Unknown attribute.
255	No error.

8.4.8 Parameter Number (PNU)

Bits 0–11 transfer parameter numbers. The function of the relevant parameter is defined in the parameter description in the VLT® Flow Drive FC 111 Programming Guide.

8.4.9 Index (IND)

The index is used with the parameter number to read/ write access parameters with an index, for example, *parameter 15-30 Alarm Log: Error Code*. The index consists of 2 bytes: a low byte and a high byte. Only the low byte is used as an index.

8.4.10 Parameter Value (PWE)

The parameter value block consists of 2 words (4 bytes), and the value depends on the defined command (AK). The master prompts for a parameter value when the PWE block contains no value. To change a parameter value (write), write the new value in the PWE block and send from the master to the follower.

When a follower responds to a parameter request (read command), the present parameter value in the PWE block is transferred and returned to the master. If a parameter contains several data options, for example *parameter 0-01 Language*, select the data value by entering the value in the PWE block. Serial communication is only capable of reading parameters containing data type 9 (text string).

Parameter 15-40 FC Type to parameter 15-53 Power Card Serial Number contain data type 9. For example, read the unit size and mains voltage range in *parameter 15-40 FC Type*. When a text string is transferred (read), the length of the telegram is variable, and the texts are of different lengths. The telegram length is defined in the 2nd byte of the telegram (LGE). When using text transfer, the index character indicates whether it is a read or a write command.

To read a text via the PWE block, set the parameter command (AK) to F hex. The index character high-byte must be 4.

8.4.11 Data Types Supported by the Drive

Table 56: Data Types

Data types	Description
3	Integer 16
4	Integer 32
5	Unsigned 8 ⁽¹⁾
6	Unsigned 16 ⁽¹⁾
7	Unsigned 32 ⁽¹⁾
9	Text string
10	Byte string
13	Time difference
33	Reserved
35	Bit sequence

¹ Unsigned means that there is no operational sign in the telegram.

8.4.12 Conversion

The Programming Guide contains the descriptions of attributes of each parameter. Parameter values are transferred as whole numbers only. Conversion factors are used to transfer decimals.

Parameter 4-12 Motor Speed Low Limit [Hz] has a conversion factor of 0.1. To preset the minimum frequency to 10 Hz, transfer the value 100. A conversion factor of 0.1 means that the value transferred is multiplied by 0.1. The value 100 is thus perceived as 10.0.

Table 57: Conversion

Conversion index	Conversion factor
74	3600
2	100
1	10
0	1
-1	0.1
-2	0.01
-3	0.001
-4	0.0001

Conversion index	Conversion factor
-5	0.00001

8.4.13 Process Words (PCD)

The block of process words is divided into 2 blocks of 16 bits, which always occur in the defined sequence.

Table 58: Process Words (PCD)

PCD 1	PCD 2
Control telegram (master->follower control word)	Reference value
Control telegram (follower->master) status word	Present output frequency

8.5 Examples

8.5.1 Writing a Parameter Value

Change *parameter 4-14 Motor Speed High Limit [Hz]* to 100 Hz.

Write the data in EEPROM.

PKE = E19E hex - Write single word in *parameter 4-14 Motor Speed High Limit [Hz]*:

- IND = 0000 hex.
- PWE_{HIGH} = 0000 hex.
- PWE_{LOW} = 03E8 hex.

Data value 1000, corresponding to 100 Hz, see [8.4.12 Conversion](#).

The telegram looks like the following illustration.

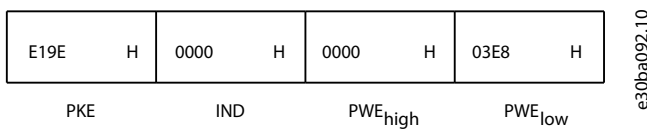

Illustration 73: Telegram

NOTICE

Parameter 4-14 Motor Speed High Limit [Hz] is a single word, and the parameter command for write in EEPROM is E. *Parameter 4-14 Motor Speed High Limit [Hz]* is 19E in hexadecimal.

The response from the follower to the master is shown in the following illustration.

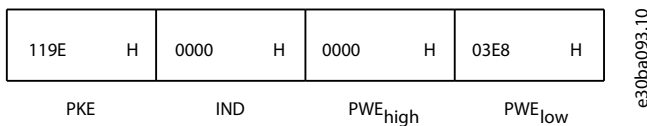

Illustration 74: Response from Master

8.5.2 Reading a Parameter Value

Read the value in *parameter 3-41 Ramp 1 Ramp Up Time*.

PKE = 1155 hex - Read parameter value in *parameter 3-41 Ramp 1 Ramp Up Time*:

- IND = 0000 hex.
- PWE_{HIGH} = 0000 hex.
- PWE_{LOW} = 0000 hex.

1155	H	0000	H	0000	H	0000	H
PKE		IND		PWE _{high}		PWE _{low}	

e30ba094.10

Illustration 75: Telegram

If the value in *parameter 3-41 Ramp 1 Ramp Up Time* is 10 s, the response from the follower to the master is shown in the following illustration.

1155	H	0000	H	0000	H	03E8	H
PKE		IND		PWE _{high}		PWE _{low}	

e30ba267.10

Illustration 76: Response

3E8 hex corresponds to 1000 decimal. The conversion index for *parameter 3-41 Ramp 1 Ramp Up Time* is -2, that is, 0.01. *Parameter 3-41 Ramp 1 Ramp Up Time* is of the type Unsigned 32.

8.6 Modbus RTU

8.6.1 Prerequisite Knowledge

Danfoss assumes that the installed controller supports the interfaces in this manual, and strictly observes all requirements and limitations stipulated in the controller and drive.

The built-in Modbus RTU (remote terminal unit) is designed to communicate with any controller that supports the interfaces defined in this manual. It is assumed that the user has full knowledge of the capabilities and limitations of the controller.

8.6.2 Modbus RTU Overview

Regardless of the type of physical communication networks, this section describes the process that a controller uses to request access to another device. This process includes how the Modbus RTU responds to requests from another device, and how errors are detected and reported. It also establishes a common format for the layout and contents of telegram fields.

During communications over a Modbus RTU network, the protocol:

- Determines how each controller learns its device address.
- Recognizes a telegram addressed to it.
- Determines which actions to take.
- Extracts any data or other information contained in the telegram.

If a reply is required, the controller constructs the reply telegram and sends it. Controllers communicate using a master/follower technique in which only the master can initiate transactions (called queries). Followers respond by supplying the requested data to the master, or by acting as requested in the query. The master can address individual followers, or initiate a broadcast telegram to all followers. Followers return a response to queries that are addressed to them individually. No responses are returned to broadcast queries from the master.

The Modbus RTU protocol establishes the format for the master query by providing the following information:

- The device (or broadcast) address.
- A function code defining the requested action.
- Any data to be sent.
- An error-checking field.

The response telegram of the follower device is also constructed using Modbus protocol. It contains fields confirming the action taken, any data to be returned, and an error-checking field. If an error occurs in receipt of the telegram, or if the follower is unable to perform the requested action, the follower constructs and sends an error message. Alternatively, a timeout occurs.

8.6.3 Drive with Modbus RTU

The drive communicates in Modbus RTU format over the built-in RS485 interface. Modbus RTU provides access to the control word and bus reference of the drive.

The control word allows the Modbus master to control several important functions of the drive:

- Start.
- Various stops:
 - Coast stop.
 - Quick stop.
 - DC brake stop.
 - Normal (ramp) stop.
- Reset after a fault trip.
- Run at various preset speeds.
- Run in reverse.
- Change the active set-up.
- Control built-in relay of the drive.

The bus reference is commonly used for speed control. It is also possible to access the parameters, read their values, and, where possible, write values to them. Accessing the parameters offers a range of control options, including controlling the setpoint of the drive when its internal PI controller is used.

8.7 Network Configuration

To enable Modbus RTU on the drive, set the following parameters:

Table 59: Network Configuration

Parameter	Setting
<i>Parameter 8-30 Protocol</i>	Modbus RTU
<i>Parameter 8-31 Address</i>	1–247
<i>Parameter 8-32 Baud Rate</i>	2400–115200
<i>Parameter 8-33 Parity/Stop Bits</i>	Even parity, 1 stop bit (default)

8.8 Modbus RTU Message Framing Structure

8.8.1 Modbus RTU Message Byte Format

The controllers are set up to communicate on the Modbus network using RTU (remote terminal unit) mode, with each byte in a telegram containing 2 4-bit hexadecimal characters. The format for each byte is shown in the following tables.

Table 60: Format for Each Byte

Start bit	Data byte	Stop/ parity	Stop

Table 61: Byte Details

Coding system	8-bit binary, hexadecimal 0–9, A–F. 2 hexadecimal characters contained in each 8-bit field of the telegram.
Bits per byte	<ul style="list-style-type: none"> • 1 start bit. • 8 data bits, least significant bit sent first. • 1 bit for even/odd parity; no bit for no parity. • 1 stop bit if parity is used; 2 bits if no parity.
Error check field	Cyclic redundancy check (CRC).

8.8.2 Modbus RTU Telegram Structure

The transmitting device places a Modbus RTU telegram into a frame with a known beginning and ending point. This allows receiving devices to begin at the start of the telegram, read the address portion, determine which device is addressed (or all devices, if the telegram is broadcast), and to recognize when the telegram is completed. Partial telegrams are detected and errors set as a result. Characters for transmission must be in hexadecimal 00–FF format in each field. The drive continuously monitors the network bus, also during silent intervals. When the 1st field (the address field) is received, each drive or device decodes it to determine which device is being addressed. Modbus RTU telegrams addressed to 0 are broadcast telegrams. No response is allowed for broadcast telegrams. A typical telegram frame is shown in the following table.

Table 62: Typical Modbus RTU Telegram Structure

Start	Address	Function	Data	CRC check	End
T1-T2-T3- T4	8 bits	8 bits	N x 8 bits	16 bits	T1-T2-T3- T4

8.8.3 Start/Stop Field

Telegrams start with a silent period of at least 3.5 character intervals. The silent period is implemented as a multiple of character intervals at the selected network baud rate (shown as Start T1-T2-T3-T4). The 1st field to be transmitted is the device address. Following the last transmitted character, a similar period of at least 3.5 character intervals marks the end of the telegram. A new telegram can begin after this period.

Transmit the entire telegram frame as a continuous stream. If a silent period of more than 1.5 character intervals occurs before completion of the frame, the receiving device flushes the incomplete telegram and assumes that the next byte is the address field of a new telegram. Similarly, if a new telegram begins before 3.5 character intervals after a previous telegram, the receiving device considers it a continuation of the previous telegram. This behavior causes a timeout (no response from the follower), since the value in the final CRC field is not valid for the combined telegrams.

8.8.4 Address Field

The address field of a telegram frame contains 8 bits. Valid follower device addresses are in the range of 0–247 decimal. The individual follower devices are assigned addresses in the range of 1–247. 0 is reserved for broadcast mode, which all followers recognize. A master addresses a follower by placing the follower address in the address field of the telegram. When the follower sends its response, it places its own address in this address field to let the master know which follower is responding.

8.8.5 Function Field

The function field of a telegram frame contains 8 bits. Valid codes are in the range of 1–FF. Function fields are used to send telegrams between master and follower. When a telegram is sent from a master to a follower device, the function code field tells the follower what kind of action to perform. When the follower responds to the master, it uses the function code field to indicate either a normal (errorfree) response, or that some kind of error occurred (called an exception response).

For a normal response, the follower simply echoes the original function code. For an exception response, the follower returns a code that is equivalent to the original function code with its most significant bit set to logic 1. In addition, the follower places a unique code into the data field of the response telegram. This code tells the master what kind of error occurred, or the reason for the exception. Also refer to [8.8.10.2 Function Codes Supported by Modbus RTU](#) and [8.8.10.3 Modbus Exception Codes](#).

8.8.6 Data Field

The data field is constructed using sets of 2 hexadecimal digits, in the range of 00–FF hexadecimal. These digits are made up of 1 RTU character. The data field of telegrams sent from a master to a follower device contains additional information which the follower must use to perform accordingly.

The information can include items such as:

- Coil or register addresses.
- The quantity of items to be handled.
- The count of actual data bytes in the field.

8.8.7 CRC Check Field

Telegrams include an error-checking field, operating based on a cyclic redundancy check (CRC) method. The CRC field checks the contents of the entire telegram. It is applied regardless of any parity check method used for the individual characters of the telegram. The transmitting device calculates the CRC value and appends the CRC as the last field in the telegram. The receiving device recalculates a CRC during receipt of the telegram and compares the calculated value to the actual value received in the CRC field. 2 unequal values result in bus timeout. The error-checking field contains a 16-bit binary value implemented as 2 8-bit bytes. After the

implementation, the low-order byte of the field is appended first, followed by the high-order byte. The CRC high-order byte is the last byte sent in the telegram.

8.8.8 Coil Register Addressing

8.8.8.1 Introduction

In Modbus, all data is organized in coils and holding registers. Coils hold a single bit, whereas holding registers hold a 2 byte word (that is 16 bits). All data addresses in Modbus telegrams are referenced to 0. The 1st occurrence of a data item is addressed as item number 0. For example: The coil known as coil 1 in a programmable controller is addressed as coil 0000 in the data address field of a Modbus telegram. Coil 127 decimal is addressed as coil 007Ehex (126 decimal).

Holding register 40001 is addressed as register 0000 in the data address field of the telegram. The function code field already specifies a holding register operation. Therefore, the 4XXXX reference is implicit. Holding register 40108 is addressed as register 006Bhex (107 decimal).

8.8.8.2 Coil Register

Table 63: Coil Register

Coil number	Description	Signal direction
1–16	Drive control word.	Master to follower
17–32	Drive speed or setpoint reference range 0x0– 0xFFFF (-200% ... ~200%).	Master to follower
33–48	Drive status word.	Follower to master
49–64	Open-loop mode: Drive output frequency. Closed-loop mode: Drive feedback signal.	Follower to master
65	Parameter write control (master to follower).	Master to follower
	0 = Parameter changes are written to the RAM of the drive.	
	1 = Parameter changes are written to the RAM and EEPROM of the drive.	
66–65536	Reserved.	–

8.8.8.3 Drive Control Word (FC Profile)

Table 64: Drive Control Word (FC Profile)

Coil	0	1
01	Preset reference lsb	
02	Preset reference msb	
03	DC brake	No DC brake
04	Coast stop	No coast stop
05	Quick stop	No quick stop
06	Freeze frequency	No freeze frequency
07	Ramp stop	Start
08	No reset	Reset
09	No jog	Jog
10	Ramp 1	Ramp 2

Coil	0	1
11	Data not valid	Data valid
12	Relay 1 off	Relay 1 on
13	Relay 2 off	Relay 2 on
14	Set up LSB	
15	–	
16	No reversing	Reversing

8.8.8.4 Drive Status Word (FC Profile)

Table 65: Drive Status Word (FC Profile)

Coil	0	1
33	Control not ready	Control ready
34	Drive not ready	Drive ready
35	Coast stop	Safety closed
36	No alarm	Alarm
37	Not used	Not used
38	Not used	Not used
39	Not used	Not used
40	No warning	Warning
41	Not at reference	At reference
42	Hand mode	Auto mode
43	Out of frequency range	In frequency range
44	Stopped	Running
45	Not used	Not used
46	No voltage warning	Voltage warning
47	Not in current limit	Current limit
48	No thermal warning	Thermal warning

8.8.8.5 Address/Registers

Table 66: Address/Registers

Bus address	Bus register ⁽¹⁾	PLC register	Content	Access	Description
0	1	40001	Reserved	–	Reserved for legacy drives VLT® 5000 and VLT® 2800.
1	2	40002	Reserved	–	Reserved for legacy drives VLT® 5000 and VLT® 2800.
2	3	40003	Reserved	–	Reserved for legacy drives VLT® 5000 and VLT® 2800.

Bus address	Bus register ⁽¹⁾	PLC register	Content	Access	Description
3	4	40004	Free	–	–
4	5	40005	Free	–	–
5	6	40006	Modbus configuration	Read/Write	TCP only. Reserved for Modbus TCP (<i>parameter 12-28 Store Data Values</i> and <i>parameter 12-29 Store Always - stored in</i> , for example, EEPROM).
6	7	40007	Last fault code	Read only	Fault code received from parameter database, refer to WHAT 38295 for details.
7	8	40008	Last error register	Read only	Address of register with which last error occurred, refer to WHAT 38296 for details.
8	9	40009	Index pointer	Read/Write	Subindex of parameter to be accessed. Refer to WHAT 38297 for details.
9	10	40010	<i>Parameter 0-01 Language</i>	Dependent on parameter access	<i>Parameter 0-01 Language</i> (Modbus register = 10 parameter number) 20 bytes space reserved for parameter in Modbus map.
19	20	40020	Free	–	–
29	30	40030	<i>Parameter 0-03 Regional Settings</i>	Dependent on parameter access	<i>Parameter 0-03 Regional Settings</i> 20 bytes space reserved for parameter in Modbus map.

¹ Value written in the Modbus RTU telegram must be 1 or less than the register number. For example, Read Modbus Register 1 by writing value 0 in the telegram.

8.8.9 Access via PCD Write/read

The advantage of using the PCD write/read configuration is that the controller can write or read more data in 1 telegram. Up to 63 registers can be read or written to via the function code read holding register or write multiple registers in 1 telegram. The structure is also flexible so that only 2 registers can be written to and 10 registers can be read from the controller.

The PCD write list is data sent from the controller to the drive, the data includes control word, reference, and application dependent data like minimum reference and ramp times, and so on.

N O T I C E

The control word and reference is always sent in the list from the controller to the drive.

The PCD write list is set up in *parameter 8-42 PCD Write Configuration*.

The PCD read list is data sent from the drive to the controller like status word, main actual value, and application dependent data like running hours, motor current, and alarm word.

N O T I C E

The status word and main actual value is always sent in the list from the drive to the controller.

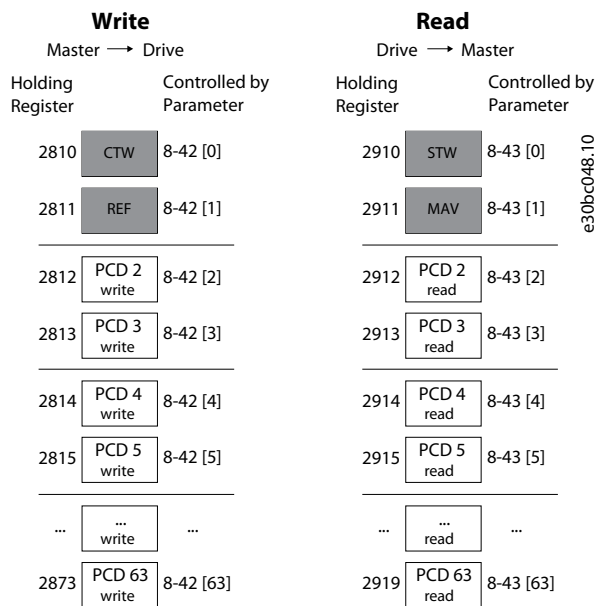

Illustration 77: Accessing via PCD write/read

NOTICE

The boxes marked in gray are not changeable, they are default values.

NOTICE

The 32-bit parameters must be mapped inside the 32-bit boundaries (PCD2 & PCD3 or PCD4 & PCD5, and so on), where the parameter number is mapped twice to *parameter 8-42 PCD Write Configuration* or *parameter 8-43 PCD Read Configuration*.

8.8.10 How to Control the Drive

8.8.10.1 Introduction

This section describes codes which can be used in the function and data fields of a Modbus RTU telegram.

8.8.10.2 Function Codes Supported by Modbus RTU

Modbus RTU supports use of the following function codes in the function field of a telegram:

Table 67: Function Codes

Function	Function code (hex)
Read coils	1
Read holding registers	3
Write single coil	5
Write single register	6
Write multiple coils	F
Write multiple registers	10
Get comm. event counter	B
Report follower ID	11
Read write multiple registers	17

Table 68: Function Codes

Function	Function code	Subfunction code	Subfunction
Diagnostics	8	1	Restart communication.
		2	Return diagnostic register.
		10	Clear counters and diagnostic register.
		11	Return bus message count.
		12	Return bus communication error count.
		13	Return follower error count.
		14	Return follower message count.

8.8.10.3 Modbus Exception Codes

For a full explanation of the structure of an exception code response, refer to [8.8.5 Function Field](#).

Table 69: Modbus Exception Codes

Code	Name	Meaning
1	Illegal function	The function code received in the query is not an allowable action for the server (or follower). This may be because the function code is only applicable to newer devices and was not implemented in the unit selected. It could also indicate that the server (or follower) is in the wrong state to process a request of this type, for example because it is not configured and is being asked to return register values.
2	Illegal data address	The data address received in the query is not an allowable address for the server (or follower). More specifically, the combination of reference number and transfer length is invalid. For a controller with 100 registers, a request with offset 96 and length 4 succeeds, while a request with offset 96 and length 5 generates exception 02.
3	Illegal data value	A value contained in the query data field is not an allowable value for server (or follower). This indicates a fault in the structure of the remainder of a complex request, such as that the implied length is incorrect. It does NOT mean that a data item submitted for storage in a register has a value outside the expectation of the application program, since the Modbus protocol is unaware of the significance of any value of any register.
4	Follower device failure	An unrecoverable error occurred while the server (or follower) was attempting to perform the requested action.

8.9 How to Access Parameters

8.9.1 Parameter Handling

The PNU (parameter number) is translated from the register address contained in the Modbus read or write telegram. The parameter number is translated to Modbus as (10 x parameter number) decimal.

Examples

Reading *parameter 3-12 Catch up/slow Down Value* (16 bit): The holding register 3120 holds the parameters value. A value of 1352 (decimal), means that the parameter is set to 12.52%.

Reading *parameter 3-14 Preset Relative Reference* (32 bit): The holding registers 3410 and 3411 hold the parameters values. A value of 11300 (decimal), means that the parameter is set to 1113.00.

For information on the parameters, size, and conversion index, see the drive's Programming Guide.

8.9.2 Storage of Data

The coil 65 decimal determines whether data written to the drive is stored in EEPROM and RAM (coil 65 = 1), or only in RAM (coil 65 = 0).

8.9.3 IND (Index)

Some parameters in the drive are array parameters, for example *parameter 3-10 Preset Reference*. Since the Modbus does not support arrays in the holding registers, the drive has reserved the holding register 9 as pointer to the array. Before reading or writing an array parameter, set the holding register 9. Setting holding register to the value of 2 causes all following read/write to array parameters to be to the index 2.

8.9.4 Text Blocks

Parameters stored as text strings are accessed in the same way as the other parameters. The maximum text block size is 20 characters. If a read request for a parameter is for more characters than the parameter stores, the response is truncated. If the read request for a parameter is for fewer characters than the parameter stores, the response is space filled.

8.9.5 Conversion Factor

A parameter value can only be transferred as a whole number. To transfer decimals, use a conversion factor.

8.9.6 Parameter Values

Standard data types

Standard data types are int 16, int 32, uint 8, uint 16, and uint 32. They are stored as 4x registers (40001–4FFFF). The parameters are read using function 03 hex read holding registers. Parameters are written using the function 6 hex preset single register for 1 register (16 bits), and the function 10 hex preset multiple registers for 2 registers (32 bits). Readable sizes range from 1 register (16 bits) up to 10 registers (20 characters).

Non-standard data types

Non-standard data types are text strings and are stored as 4x registers (40001–4FFFF). The parameters are read using function 03 hex read holding registers and written using function 10 hex preset multiple registers. Readable sizes range from 1 register (2 characters) up to 10 registers (20 characters).

8.10 Examples

8.10.1 Introduction

The following examples show various Modbus RTU commands.

8.10.2 Read Coil Status (01 hex)

Description

This function reads the ON/OFF status of discrete outputs (coils) in the drive. Broadcast is never supported for reads.

Query

The query telegram specifies the starting coil and quantity of coils to be read. Coil addresses start at 0, that is, coil 33 is addressed as 32. Example of a request to read coils 33–48 (status word) from follower device 01.

Table 70: Query

Field name	Example (hex)
Follower address	01 (drive address)
Function	01 (read coils)
Starting address HI	00
Starting address LO	20 (32 decimals) coil 33
Number of points HI	00
Number of points LO	10 (16 decimals)
Error check (CRC)	–

Response

The coil status in the response telegram is packed as 1 coil per bit of the data field. Status is indicated as: 1 = ON; 0 = OFF. The lsb of the 1st data byte contains the coil addressed in the query. The other coils follow toward the high-order end of this byte, and from low order to high order in subsequent bytes.

If the returned coil quantity is not a multiple of 8, the remaining bits in the final data byte are padded with values 0 (toward the high-order end of the byte). The byte count field specifies the number of complete bytes of data.

Table 71: Response

Field name	Example (hex)
Follower address	01 (drive address)
Function	01 (read coils)
Byte count	02 (2 bytes of data)
Data (coils 40–33)	07
Data (coils 48–41)	06 (STW = 0607hex)
Error check (CRC)	–

N O T I C E

Coils and registers are addressed explicitly with an offset of -1 in Modbus. For example, coil 33 is addressed as coil 32.

8.10.3 Force/Write Single Coil (05 hex)

Description

This function forces the coil to either ON or OFF. When broadcast, the function forces the same coil references in all attached followers.

Query

The query telegram specifies the coil 65 (parameter write control) to be forced. Coil addresses start at 0, that is, coil 65 is addressed as 64. Force data = 00 00 hex (OFF) or FF 00 hex (ON).

Table 72: Query

Field name	Example (hex)
Follower address	01 (drive address)
Function	05 (write single coil)
Coil address HI	00
Coil address LO	40 (64 decimal) Coil 65
Force data HI	FF
Force data LO	00 (FF 00 = ON)
Error check (CRC)	–

Response

The normal response is an echo of the query, returned after the coil state has been forced.

Table 73: Response

Field name	Example (hex)
Follower address	01
Function	05
Force data HI	FF
Force data LO	00

Field name	Example (hex)
Quantity of coils HI	00
Quantity of coils LO	01
Error check (CRC)	–

8.10.4 Force/Write Multiple Coils (0F hex)

Description

This function forces each coil in a sequence of coils to either on or off. When broadcasting, the function forces the same coil references in all attached followers.

Query

The query telegram specifies the coils 17–32 (speed setpoint) to be forced.

N O T I C E

Coil addresses start at 0, that is, coil 17 is addressed as 16.

Table 74: Query

Field name	Example (hex)
Follower address	01 (drive address)
Function	0F (write multiple coils)
Coil address HI	00
Coil address LO	10 (coil address 17)
Quantity of coils HI	00
Quantity of coils LO	10 (16 coils)
Byte count	02
Force data HI (Coils 8–1)	20
Force data LO (Coils 16–9)	00 (reference = 2000 hex)
Error check (CRC)	–

Response

The normal response returns the follower address, function code, starting address, and quantity of coils forced.

Table 75: Response

Field name	Example (hex)
Follower address	01 (drive address)
Function	0F (write multiple coils)
Coil address HI	00
Coil address LO	10 (coil address 17)
Quantity of coils HI	00
Quantity of coils LO	10 (16 coils)

Field name	Example (hex)
Error check (CRC)	–

8.10.5 Read Holding Registers (03 hex)

Description

This function reads the contents of holding registers in the follower.

Query

The query telegram specifies the starting register and quantity of registers to be read. Register addresses start at 0, that is, registers 1–4 are addressed as 0–3.

Example: Read *parameter 3-03 Maximum Reference*, register 03030.

Table 76: Query

Field name	Example (hex)
Follower address	01
Function	03 (Read holding registers)
Starting address HI	0B (Register address 3029)
Starting address LO	D5 (Register address 3029)
Number of points HI	00
Number of points LO	02 – (<i>parameter 3-03 Maximum Reference</i> is 32 bits long, that is, 2 registers)
Error check (CRC)	–

Response

The register data in the response telegram is packed as 2 bytes per register, with the binary contents right justified within each byte. For each register, the 1st byte contains the high-order bits, and the 2nd contains the low-order bits.

Example: hex 000088B8 = 35.000 = 35 Hz.

Table 77: Response

Field name	Example (hex)
Follower address	01
Function	03
Byte count	04
Data HI (register 3030)	00
Data LO (register 3030)	16
Data HI (register 3031)	E3
Data LO (register 3031)	60
Error check (CRC)	–

8.10.6 Preset Single Register (06 hex)

Description

This function presets a value into a single holding register.

Query

The query telegram specifies the register reference to be preset. Register addresses start at 0, that is, register 1 is addressed as 0.

Example: Write to *parameter 1-00 Configuration Mode*, register 1000.

Table 78: Query

Field name	Example (hex)
Follower address	01
Function	06
Starting address HI	03 (register address 999)
Starting address LO	E7 (register address 999)
Preset data HI	00
Preset data LO	01
Error check (CRC)	–

Response

The normal response is an echo of the query, returned after the register contents have been passed.

Table 79: Response

Field name	Example (hex)
Follower address	01
Function	06
Register address HI	03
Register address LO	E7
Preset data HI	00
Preset data LO	01
Error check (CRC)	–

8.10.7 Preset Multiple Registers (10 hex)**Description**

This function presets values into a sequence of holding registers.

Query

The query telegram specifies the register references to be preset. Register addresses start at 0, that is, register 1 is addressed as 0. Example of a request to preset 2 registers (set *parameter 1-24 Motor Current* to 738 (7.38 A)):

Table 80: Query

Field name	Example (hex)
Follower address	01
Function	10
Starting address HI	04
Starting address LO	07
Number of registers HI	00
Number of registers LO	02
Byte count	04
Write data HI (Register 4: 1049)	00

Field name	Example (hex)
Write data LO (Register 4: 1049)	00
Write data HI (Register 4: 1050)	02
Write data LO (Register 4: 1050)	E2
Error check (CRC)	–

Response

The normal response returns the follower address, function code, starting address, and quantity of registers preset.

Table 81: Response

Field name	Example (hex)
Follower address	01
Function	10
Starting address HI	04
Starting address LO	19
Number of registers HI	00
Number of registers LO	02
Error check (CRC)	–

8.10.8 Read/Write Multiple Registers (17 hex)

Description

This function code performs a combination of 1 read operation and 1 write operation in a single MODBUS transaction. The write operation is performed before read.

Query

The query message specifies the starting address and number of holding registers to be read as well as the starting address, number of holding registers, and the data to be written. Holding registers are addressed starting at 0. Example of a request to set *parameter 1-24 Motor Current* to 738 (7.38 A) and read *parameter 3-03 Maximum Reference* which has value 50000 (50,000 Hz):

Table 82: Query

Field name	Example (hex)
Follower address	01
Function	17
Reading starting address HI	0B (Register address 3029)
Read starting address LO	D5 (Register address 3029)
Quantity to read HI	00
Quantity to read LO	02 (<i>Parameter 3-03 Maximum Reference</i> is 32 bits long, that is, 2 registers)
Write starting address HI	04 (Register address 1239)
Write starting address LO	D7 (Register address 1239)
Quantity to write HI	00
Quantity to write LO	02

Field name	Example (hex)
Write byte count	04
Write registers value HI	00
Write registers value LO	00
Write registers value HI	02
Write registers value LO	0E
Error check (CRC)	-

Response

The normal response contains the data from the group of registers that were read. The byte count field specifies the quantity of bytes to follow in the read data field.

Table 83: Response

Field name	Example (hex)
Follower address	01
Function	17
Byte count	04
Read registers value HI	00
Read registers value LO	00
Read registers value HI	C3
Read registers value LO	50
Error check (CRC)	-

8.11 Danfoss FC Control Profile

8.11.1 Control Word According to FC Profile (8-10 Protocol = FC Profile)

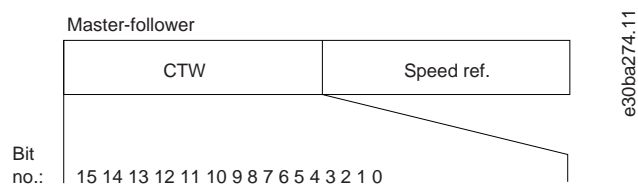

Illustration 78: Control Word According to FC Profile

Table 84: Control Word According to FC Profile

Bit	Bit value = 0	Bit value = 1
00	Reference value	External selection lsb
01	Reference value	External selection msb
02	DC brake	Ramp
03	Coasting	No coasting
04	Quick stop	Ramp

Bit	Bit value = 0	Bit value = 1
05	Hold output frequency	Use ramp
06	Ramp stop	Start
07	No function	Reset
08	No function	Jog
09	Ramp 1	Ramp 2
10	Data invalid	Data valid
11	Relay 01 open	Relay 01 active
12	Relay 02 open	Relay 02 active
13	Parameter set-up	Selection lsb
14	Parameter set-up	Selection msb
15	No function	Reverse

8.11.2 Explanation of Each Control Bit

8.11.2.1 Bits 00/01

Bits 00 and 01 are used to select among the 4 reference values, which are preprogrammed in *parameter 3-10 Preset Reference* according to the following table.

Table 85: Control Bits

Programmed reference value	Parameter	Bit 01	Bit 00
1	<i>Parameter 3-10 Preset Reference</i> [0]	0	0
2	<i>Parameter 3-10 Preset Reference</i> [1]	0	1
3	<i>Parameter 3-10 Preset Reference</i> [2]	1	0
4	<i>Parameter 3-10 Preset Reference</i> [3]	1	1

N O T I C E

In *parameter 8-56 Preset Reference Select*, define how bit 00/01 gates with the corresponding function on the digital inputs.

8.11.2.2 Bit 02, DC Brake

Bit 02 = 0: Leads to DC braking and stop. Set braking current and duration in *parameter 2-01 DC Brake Current* and *parameter 2-02 DC Braking Time*.

Bit 02 = 1: Leads to ramping.

8.11.2.3 Bit 03, Coasting

Bit 03 = 0: The drive immediately releases the motor (the output transistors are shut off), and it coasts to a standstill.

Bit 03 = 1: If the other starting conditions are met, the drive starts the motor.

In *parameter 8-50 Coasting Select*, define how bit 03 gates with the corresponding function on a digital input.

8.11.2.4 Bit 04, Quick Stop

Bit 04 = 0: Makes the motor speed ramp down to stop (set in *parameter 3-81 Quick Stop Ramp Time*).

8.11.2.5 Bit 05, Hold Output Frequency

Bit 05 = 0: The present output frequency (in Hz) freezes. Change the frozen output frequency only with the digital inputs programmed to [21] *Speed up* and [22] *Speed down* (parameter 5-10 Terminal 18 Digital Input to parameter 5-13 Terminal 29 Digital Input).

N O T I C E

If freeze output is active, the drive can only be stopped in 1 of the following ways:

- Bit 03 coast stop.
- Bit 02 DC brake.
- Digital input programmed to [5] *DC brake inverse*, [2] *Coast inverse*, or [3] *Coast and reset inv* (parameter 5-10 Terminal 18 Digital Input to parameter 5-13 Terminal 29 Digital Input).

8.11.2.6 Bit 06, Ramp Stop/Start

Bit 06 = 0: Causes a stop and makes the motor speed ramp down to stop via the selected ramp-down parameter.

Bit 06 = 1: Allows the drive to start the motor if the other starting conditions are met.

In parameter 8-53 *Start Select*, define how bit 06 ramp stop/start gates with the corresponding function on a digital input.

8.11.2.7 Bit 07, Reset

Bit 07 = 0: No reset.

Bit 07 = 1: Resets a trip. Reset is activated on the leading signal edge, that is, when changing from logic 0 to logic 1.

8.11.2.8 Bit 08, Jog

Bit 08 = 1: Parameter 3-11 *Jog Speed [Hz]* determines the output frequency.

8.11.2.9 Bit 09, Selection of Ramp 1/2

Bit 09 = 0: Ramp 1 is active (parameter 3-41 *Ramp 1 Ramp Up Time* to parameter 3-42 *Ramp 1 Ramp Down Time*).

Bit 09 = 1: Ramp 2 (parameter 3-51 *Ramp 2 Ramp Up Time* to parameter 3-52 *Ramp 2 Ramp Down Time*) is active.

8.11.2.10 Bit 10, Data Not Valid/Data Valid

Tell the drive whether to use or ignore the control word.

Bit 10 = 0: The control word is ignored.

Bit 10 = 1: The control word is used. This function is relevant because the telegram always contains the control word, regardless of the telegram type. If the control word is not needed when updating or reading parameter, turn it off.

8.11.2.11 Bit 11, Relay 01

Bit 11 = 0: Relay 01 not activated.

Bit 11 = 1: Relay 01 activated if [36] *Control word bit 11* is selected in parameter 5-40 *Function Relay*.

8.11.2.12 Bit 12, Relay 02

Bit 12 = 0: Relay 02 is not activated.

Bit 12 = 1: Relay 02 is activated if [37] *Control word bit 12* is selected in parameter 5-40 *Function Relay*.

8.11.2.13 Bit 13, Set-up Selection

Use bit 13 to select from the 2 set-ups according to the following table.

The function is only possible when [9] *Multi set-ups* is selected in parameter 0-10 *Active Set-up*.

Table 86: Set-up selection

Setup	Bit 13
1	0
2	1

NOTICE

To define how bit 13 gates with the corresponding function on the digital inputs, use *parameter 8-55 Set-up Select*.

8.11.2.14 Bit 15, Reverse

Bit 15 = 0: No reversing.

Bit 15 = 1: Reversing. In the default setting, reversing is set to [0] Digital input in *parameter 8-54 Reversing Select*. Bit 15 causes reversing only when [1] Bus, [2] Logic AND or [3] Logic OR is selected.

8.11.3 Status Word According to FC Profile (STW)

Set *parameter 8-30 Protocol* to [0] FC.

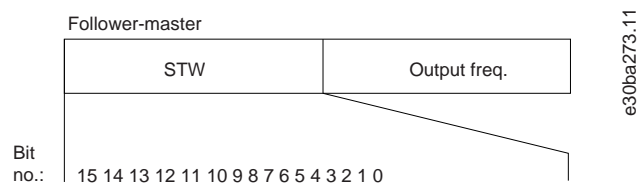

Illustration 79: Status Word

Table 87: Status Word According to FC Profile

Bit	Bit = 0	Bit = 1
00	Control not ready	Control ready
01	Drive not ready	Drive ready
02	Coasting	Enable
03	No error	Trip
04	No error	Error (no trip)
05	Reserved	–
06	No error	Triplock
07	No warning	Warning
08	Speed≠reference	Speed=reference
09	Local operation	Bus control
10	Out of frequency limit	Frequency limit OK
11	No operation	In operation
12	Drive OK	Stopped, auto start
13	Voltage OK	Voltage exceeded
14	Torque OK	Torque exceeded
15	Timer OK	Timer exceeded

8.11.4 Explanation of Each Status Bit

8.11.4.1 Bit 00, Control Not Ready/Ready

Bit 00=0: The drive trips.

Bit 00=1: The drive controls are ready but the power component does not necessarily receive any supply (if there is 24 V external supply to controls).

8.11.4.2 Bit 01, Drive Ready

Bit 01=0: The drive is not ready.

Bit 01=1: The drive is ready for operation, but the coasting command is active via the digital inputs or via serial communication.

8.11.4.3 Bit 02, Coast Stop

Bit 02=0: The drive releases the motor.

Bit 02=1: The drive starts the motor with a start command.

8.11.4.4 Bit 03, No Error/Trip

Bit 03=0: The drive is not in fault mode.

Bit 03=1: The drive trips. To re-establish operation, press [Reset].

8.11.4.5 Bit 04, No Error/Error (No Trip)

Bit 04=0: The drive is not in fault mode.

Bit 04=1: The drive shows an error but does not trip.

8.11.4.6 Bit 05, Not Used

Bit 05 is not used in the status word.

8.11.4.7 Bit 06, No Error/Triplock

Bit 06=0: The drive is not in fault mode.

Bit 06=1: The drive is tripped and locked.

8.11.4.8 Bit 07, No Warning/Warning

Bit 07=0: There are no warnings.

Bit 07=1: A warning has occurred.

8.11.4.9 Bit 08, Speed \neq Reference/Speed=Reference

Bit 08=0: The motor runs, but the present speed is different from the preset speed reference. It might happen when the speed ramps up/down during start/stop.

Bit 08=1: The motor speed matches the preset speed reference.

8.11.4.10 Bit 09, Local Operation/Bus Control

Bit 09=0: [Off/Reset] is activated on the control unit or [2] *Local* in *parameter 3-13 Reference Site* is selected. It is not possible to control the drive via serial communication.

Bit 09=1: It is possible to control the drive via the fieldbus/serial communication.

8.11.4.11 Bit 10, Out of Frequency Limit

Bit 10=0: The output frequency has reached the value in *parameter 4-12 Motor Speed Low Limit [Hz]* or *parameter 4-14 Motor Speed High Limit [Hz]*.

Bit 10=1: The output frequency is within the defined limits.

8.11.4.12 Bit 11, No Operation/In Operation

Bit 11=0: The motor is not running.

Bit 11=1: The drive has a start signal or the output frequency is greater than 0 Hz.

8.11.4.13 Bit 12, Drive OK/Stopped, Auto Start

Bit 12=0: There is no temporary overtemperature on the drive.

Bit 12=1: The drive stops because of overtemperature but the unit does not trip and resumes operation once the overtemperature normalizes.

8.11.4.14 Bit 13, Voltage OK/Limit Exceeded

Bit 13=0: There are no voltage warnings.

Bit 13=1: The DC voltage in the drive's DC link is too low or too high.

8.11.4.15 Bit 14, Current OK/Limit Exceeded

Bit 14=0: The motor current is lower than the current limit selected in *parameter 4-18 Current Limit*.

Bit 14=1: The current limit in *parameter 4-18 Current Limit* is exceeded.

8.11.4.16 Bit 15, Thermal Level OK/Limit Exceeded

Bit 15=0: The timers for motor thermal protection and thermal protection are not exceeded 100%.

Bit 15=1: 1 of the timers exceeds 100%.

8.11.5 Bus Speed Reference Value

Speed reference value is transmitted to the drive in a relative value in %. The value is transmitted in the form of a 16-bit word. The integer value 16384 (4000 hex) corresponds to 100%. Negative figures are formatted using 2's complement. The actual output frequency (MAV) is scaled in the same way as the bus reference.

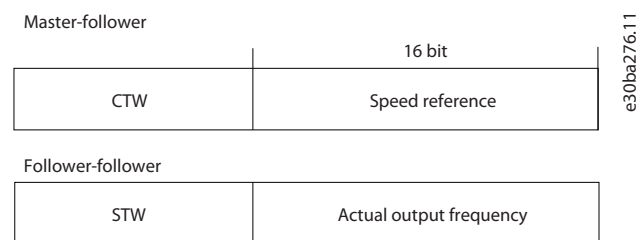

Illustration 80: Actual Output Frequency (MAV)

The reference and MAV are scaled as follows:

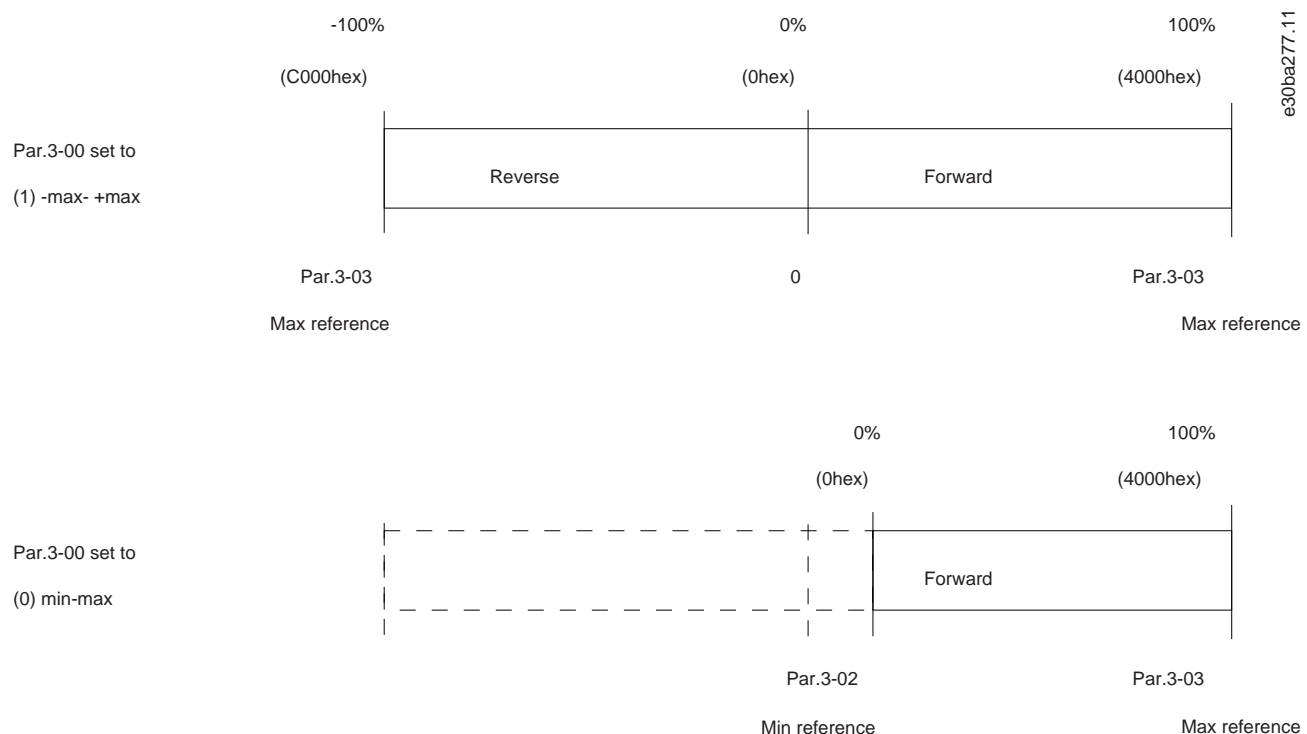

Illustration 81: Reference and MAV

9 General Specifications

9.1 Mains Supply

9.1.1 3x380–480 V AC

Table 88: 3x380–480 V AC, 0.37–15 kW (0.5–20 hp), Enclosure Sizes H1–H4

Drive	PK37	PK75	P1K5	P2K2	P3K0	P4K0	P5K5	P7K5	P11K	P15K
Typical shaft output [kW]	0.37	0.75	1.5	2.2	3.0	4.0	5.5	7.5	11.0	15.0
Typical shaft output [hp]	0.5	1.0	2.0	3.0	4.0	5.4	7.5	10.0	15.0	20.0
Protection rating IP20	H1	H1	H1	H2	H2	H2	H3	H3	H4	H4
Maximum cable size in terminals (mains, motor) [mm ² (AWG)]	4 (10)	4 (10)	4 (10)	4 (10)	4 (10)	4 (10)	4 (10)	4 (10)	16 (6)	16 (6)
Output current at 40°C (104°F) ambient temperature⁽¹⁾										
Continuous [A]	1.2	2.2	3.7	5.3	7.2	9.0	12.0	15.5	23.0	31.0
Intermittent (110% overload 60 s) [A] ⁽²⁾	1.3	2.4	4.1	5.8	7.9	9.9	13.2	17.1	25.3	34.0
Maximum input current										
Continuous [A]	1.2	2.1	3.5	4.7	6.3	8.3	11.2	15.1	22.1	29.9
Intermittent [A]	1.3	2.3	3.9	5.2	6.9	9.1	12.3	16.6	24.3	32.9
Maximum external mains fuses [A]	See 6.9.5 Recommendation of Fuses and Circuit Breakers .									
Estimated power loss [W] ⁽³⁾	15	21	57	58	83	118	131	198	274	379
Weight enclosure protection rating IP20 [kg (lb)]	2.0 (4.4)	2.0 (4.4)	2.1 (4.6)	3.3 (7.3)	3.3 (7.3)	3.4 (7.5)	4.3 (9.5)	4.5 (9.9)	7.9 (17.4)	7.9 (17.4)
Efficiency [%] ⁽⁴⁾	97.3	97.6	97.2	97.9	97.8	97.6	98.0	97.8	97.9	97.8

¹ Refer to the *chapter Derating* for the derating curves at 50°C (122°F) ambient temperature.

² The drive also supports 150% overload for 60 s when selecting 1 level higher power size.

³ Applies for dimensioning of drive cooling. If the switching frequency is higher than the default setting, the power losses may increase. LCP and typical control card power consumptions are included. For power loss data according to EN 50598-2, refer to Danfoss [MyDrive® ecoSmart](#) website.

⁴ Efficiency measured at nominal current. For energy efficiency class, see [9.2.13 Ambient Conditions \(H1–H8\)](#). For part load losses, see Danfoss [My-Drive® ecoSmart](#) website.

Table 89: 3x380–480 V AC, 18.5–90 kW (25–125 hp), Enclosure Sizes H5–H8

Drive	P18K	P22K	P30K	P37K	P45K	P55K	P75K	P90K
Typical shaft output [kW]	18.5	22.0	30.0	37.0	45.0	55.0	75.0	90.0
Typical shaft output [hp]	25.0	30.0	40.0	50.0	60.0	70.0	100.0	125.0
Protection rating IP20	H5	H5	H6	H6	H6	H7	H7	H8
Maximum cable size in terminals (mains, motor) [mm ² (AWG)]	16 (6)	16 (6)	35 (2)	35 (2)	35 (2)	50 (1)	95 (0)	120 (250 MCM)

Drive	P18K	P22K	P30K	P37K	P45K	P55K	P75K	P90K
Output current at 40°C (104°F) ambient temperature⁽¹⁾								
Continuous [A]	37.0	42.5	61.0	73.0	90.0	106.0	147.0	177.0
Intermittent (110% overload 60 s) [A] ⁽²⁾	40.7	46.8	67.1	80.3	99.0	116.0	161.0	194.0
Maximum input current								
Continuous [A]	35.2	41.5	57.0	70.0	84.0	103.0	140.0	166.0
Intermittent [A]	38.7	45.7	62.7	77.0	92.4	113.0	154.0	182.0
Maximum external mains fuses [A]	See 6.9.5 Recommendation of Fuses and Circuit Breakers .							
Estimated power loss [W] ⁽³⁾	456	523	733	922	1067	1133	1733	2141
Weight enclosure protection rating IP20 [kg (lb)]	9.5 (20.9)	9.5 (20.9)	24.5 (54)	24.5 (54)	24.5 (54)	36.0 (79.4)	36.0 (79.4)	51.0 (112.4)
Efficiency [%] ⁽⁴⁾	97.9	97.9	97.8	97.7	98	98.2	97.8	97.9

¹ Refer to the *chapter Derating* for the derating curves at 50°C (122°F) ambient temperature.

² The drive also supports 150% overload for 60 s when selecting 1 level higher power size.

³ Applies for dimensioning of drive cooling. If the switching frequency is higher than the default setting, the power losses may increase. LCP and typical control card power consumptions are included. For power loss data according to EN 50598-2, refer to Danfoss [MyDrive® ecoSmart](#) website.

⁴ Efficiency measured at nominal current. For energy efficiency class, see [9.2.13 Ambient Conditions \(H1–H8\)](#). For part load losses, see Danfoss [MyDrive® ecoSmart](#) website.

Table 90: 3x380–480 V AC, 110–315 kW (150–450 hp), Enclosure Sizes H13–H14

Drive	P110	P132	P160	P200	P250	P315
Typical shaft output [kW]	110	132	160	200	250	315
Typical shaft output [hp]	150	175	250	300	350	450
Protection rating IP20	H13	H13	H13	H14	H14	H14
Maximum cable size in terminals (mains, motor) [mm ² (AWG)]	2x95 (2x3/0)			2x185 (2x350 mcm)		
Output current at 40°C/45°C (104°F/113°F) ambient temperature⁽¹⁾						
Continuous [A]	212	260	315	395	480	588
Intermittent (110% overload 60 s) [A] ⁽²⁾	233	286	347	435	528	647
Maximum input current						
Continuous [A]	204	251	304	381	463	567
Intermittent [A]	224	276	334	419	509	623
Maximum external mains fuses [A]	See 6.9.5 Recommendation of Fuses and Circuit Breakers .					
Estimated power loss [W] ⁽³⁾⁽⁴⁾	2559	2954	3770	4116	5137	6674
Efficiency ⁽⁴⁾	0.98					

Drive	P110	P132	P160	P200	P250	P315
Output frequency [Hz]	0–500					
Heat sink overtemperature trip [°C (°F)]	110 (230)					
Weight, enclosure protection rating IP20 kg (lbs)	98 (216)			164 (362)		
Control card overtemperature trip [°C (°F)]	75 (167)			80 (176)		

¹ Refer to the *chapter Derating* for the derating curves at 50°C (122°F) ambient temperature.

² The drive also supports 150% overload for 60 s when selecting 1 level higher power size.

³ Typical power loss is at normal conditions and expected to be within $\pm 15\%$ (tolerance relates to variety in voltage and cable conditions). These values are based on a typical motor efficiency (IE/IE3 border line). Lower efficiency motors add to the power loss in the drive. Applies for dimensioning of drive cooling. If the switching frequency is higher than the default setting, the power losses can increase. LCP and typical control card power consumptions are included. For power loss data according to EN 50598-2, refer to Danfoss [MyDrive® ecoSmart](#) website. Options and customer load can add up to 30 W to the losses, though usually a fully loaded control card and options for slots A and B each add only 4 W.

⁴ Measured using 5 m (16.4 ft) shielded motor cables at rated load and rated frequency. Efficiency measured at nominal current. For energy efficiency class, see [9.2.14 Ambient Conditions \(H13–H14\)](#). For part load losses, see Danfoss [MyDrive® ecoSmart](#) website.

9.2 General Technical Data

9.2.1 Protection and Features

- Electronic motor thermal protection against overload.
- Temperature monitoring of the heat sink ensures that the drive trips if there is overtemperature.
- The drive is protected against short circuits between motor terminals U, V, W.
- When a motor phase is missing, the drive trips and issues an alarm.
- When a mains phase is missing, the drive trips or issues a warning (depending on the load).
- Monitoring of the DC-link voltage ensures that the drive trips when the DC-link voltage is too low or too high.
- The drive is protected against ground faults on motor terminals U, V, W.

9.2.2 Mains Supply

Supply voltage	380–480 V $\pm 10\%$
Supply frequency	50/60 Hz
Maximum imbalance temporary between mains phases	3.0% of rated supply voltage
True power factor (λ)	≥ 0.9 nominal at rated load
Displacement power factor ($\cos\phi$) near unity	(>0.98)
Switching on the input supply L1, L2, L3 (power-ups) enclosure sizes H1–H5	Maximum 1 time/30 s
Switching on the input supply L1, L2, L3 (power-ups) enclosure sizes H6–H8	Maximum 1 time/minute
Switching on the input supply R, S, T (power-ups) enclosure sizes H13–H14	Maximum 1 time/2 minutes
Environment according to EN 60664-1	Overvoltage category III/pollution degree 2

The unit is suitable for use on a circuit capable of delivering not more than 100000 A_{rms} symmetrical Amperes, 240/480 V maximum.

9.2.3 Motor Output (U, V, W)

Output voltage	0–100% of supply voltage
Output frequency in U/f mode (for AM motor)	0–500 Hz

Output frequency in VVC+ mode (for AM motor)	0–200 Hz
Output frequency in VVC+ mode (for PM motor)	0–400 Hz
Switching on output	Unlimited
Ramp time	0.01–3600 s

9.2.4 Cable Length and Cross-section

Maximum motor cable length, shielded/armored (EMC-correct installation)	See 3.4.3 EMC Emission Test Results .
Maximum motor cable length, unshielded/unarmored, H1–H8	50 m (164 ft)
Maximum motor cable length, shielded, H13–H14	150 m (492 ft)
Maximum motor cable length, unshielded, H13–H14	300 m (984 ft)
Maximum cross-section to motor, mains	See 9.1.1 3x380–480 V AC for more information
Cross-section DC terminals for filter feedback on enclosure sizes H1–H3	4 mm ² /12 AWG
Cross-section DC terminals for filter feedback on enclosure sizes H4–H5	16 mm ² /6 AWG
Maximum cross-section to control terminals, rigid wire, H1–H8	2.5 mm ² /14 AWG
Maximum cross-section to control terminals, rigid wire, H13–H14	1.5 mm ² /16 AWG (2x0.75 mm ²)
Maximum cross-section to control terminals, flexible cable, H1–H8	2.5 mm ² /14 AWG
Maximum cross-section to control terminals, flexible cable, H13–H14	1 mm ² /18 AWG
Maximum cross-section to control terminals, cable with enclosed core, H13–H14	0.05 mm ² /20 AWG
Minimum cross-section to control terminals, H1–H8	0.05 mm ² /30 AWG
Minimum cross-section to control terminals, H13–H14	0.25 mm ² /23 AWG

9.2.5 Digital Inputs

Programmable digital inputs	4
Terminal number	18, 19, 27, 29
Logic	PNP or NPN
Voltage level	0–24 V DC
Voltage level, logic 0 PNP	<5 V DC
Voltage level, logic 1 PNP	>10 V DC
Voltage level, logic 0 NPN	>19 V DC
Voltage level, logic 1 NPN	<14 V DC
Maximum voltage on input	28 V DC
Input resistance, R _i	Approximately 4 kΩ
Digital input 29 as thermistor input	Fault: >2.9 kΩ and no fault: <800 Ω
Digital input 29 as pulse input	Maximum frequency 32 kHz push-pull-driven & 5 kHz (O.C.)

9.2.6 Analog Inputs

Number of analog inputs	2
Terminal number	53, 54
Terminal 53 mode	<i>Parameter 16-61 Terminal 53 Setting: 1 = voltage, 0 = current</i>
Terminal 54 mode	<i>Parameter 16-63 Terminal 54 Setting: 1 = voltage, 0 = current</i>
Voltage level	0–10 V
Input resistance, R _i	Approximately 10 kΩ

Maximum voltage	20 V
Current level	0/4–20 mA (scalable)
Input resistance, R_i	<500 Ω
Maximum current	29 mA
Resolution on analog input	10 bit

9.2.7 Analog Outputs

Number of programmable analog outputs	2
Terminal number	42, 45 ⁽¹⁾
Current range at analog output	0/4–20 mA
The load resistor to common at analog out	$\leq 500 \Omega$
Maximum voltage at analog output	17 V
Accuracy on analog output	Maximum error: 0.4% of full scale
Resolution on analog output	10 bit

¹ Terminals 42 and 45 can also be programmed as digital outputs.

9.2.8 Digital Output

Number of digital outputs	4
Terminals 27 and 29	
Terminal number	27, 29 ⁽¹⁾
Voltage level at digital output	0–24 V
Maximum output current (sink and source)	40 mA
Terminals 42 and 45	
Terminal number	42, 45 ⁽²⁾
Voltage level at digital output	17 V
Maximum output current at digital output	20 mA
The load resistor at digital output	$\geq 1 \text{ k}\Omega$

¹ Terminals 27 and 29 can also be programmed as input.

² Terminals 42 and 45 can also be programmed as analog output.

The digital outputs are galvanically isolated from the supply voltage (PELV) and other high-voltage terminals.

9.2.9 RS485 Serial Communication

Terminal number	68 (P, TX+, RX+), 69 (N, TX-, RX-)
Terminal number	61 common for terminals 68 and 69

9.2.10 24 V DC Output

Terminal number	12
Maximum load	80 mA

9.2.11 Relay Output

Programmable relay output	2
Relay 01 and 02	01–03 (NC), 01–02 (NO), 04–06 (NC), 04–05 (NO)
Maximum terminal load (AC-1) ⁽¹⁾ on 01–02/04–05 (NO) (Resistive load)	250 V AC, 3 A
Maximum terminal load (AC-15) ⁽¹⁾ on 01–02/04–05 (NO) (Inductive load @ $\cos\phi$ 0.4)	250 V AC, 0.2 A

Design Guide

General Specifications

Maximum terminal load (DC-1) ⁽¹⁾ on 01–02/04–05 (NO) (Resistive load)	30 V DC, 2 A
Maximum terminal load (DC-13) ⁽¹⁾ on 01–02/04–05 (NO) (Inductive load)	24 V DC, 0.1 A
Maximum terminal load (AC-1) ⁽¹⁾ on 01–03/04–06 (NC) (Resistive load)	250 V AC, 3 A
Maximum terminal load (AC-15) ⁽¹⁾ on 01–03/04–06 (NC) (Inductive load @ cosφ 0.4)	250 V AC, 0.2 A
Maximum terminal load (DC-1) ⁽¹⁾ on 01–03/04–06 (NC) (Resistive load)	30 V DC, 2 A
Minimum terminal load on 01–03 (NC), 01–02 (NO)	24 V DC 10 mA, 24 V AC 20 mA
Environment according to EN 60664-1	Overtoltage category III/pollution degree 2

¹ IEC 60947 parts 4 and 5. Endurance of the relay varies with different load type, switching current, ambient temperature, driving configuration, working profile, and so forth. It is recommended to mount a snubber circuit when connecting inductive loads to the relays.

9.2.12 10 V DC Output

Terminal number	50
Output voltage	10.5 V ±0.5 V
Maximum load	25 mA

9.2.13 Ambient Conditions (H1–H8)

Enclosure protection rating	IP20
Enclosure kit available	IP21
Vibration test	1.0 g
Maximum relative humidity	5–95% (IEC 60721-3-3; Class 3K3 (non-condensing) during operation)
Aggressive environment (IEC 60721-3-3), coated (standard) enclosure sizes H1–H5	Class 3C3
Aggressive environment (IEC 60721-3-3), coated (optional) enclosure sizes H6–H8	Class 3C3
Test method according to IEC 60068-2-43 H2S (10 days)	
Ambient temperature ⁽¹⁾	See maximum output current at 40/50 °C (104/122 °F) in 9.1.1 3x380–480 V AC .
Minimum ambient temperature during full-scale operation	0 °C (32 °F)
Minimum ambient temperature at reduced performance (H1–H5)	-20 °C (-4 °F)
Minimum ambient temperature at reduced performance (H6–H8)	-10 °C (14 °F)
Temperature during storage/transport	-30 to +65/70 °C (-22 to +149/158 °F)
Maximum altitude above sea level without derating	1000 m (3281 ft)
Maximum altitude above sea level with derating	3000 m (9843 ft)
Derating for high altitude	See 5.4.3 Derating for Low Air Pressure and High Altitudes .
Safety standards	EN/IEC 61800-5-1
EMC standards, Emission	EN 61800-3, EN 61000-6-3/4, EN 55011, IEC 61800-3
EMC standards, Immunity	EN 61800-3, EN 61000-3-12, EN 61000-6-1/2, EN 61000-4-2, EN 61000-4-3, EN 61000-4-4, EN 61000-4-5, EN 61000-4-6

Energy efficiency class⁽²⁾

IE2

¹ Refer to *chapter Derating* for:

- Derating for high ambient temperature.
- Derating for high altitude.

² Determined according to EN 50598-2 at:

- Rated load.
- 90% rated frequency.
- Switching frequency factory setting.
- Switching pattern factory setting.

9.2.14 Ambient Conditions (H13–H14)

Enclosure protection rating	IP20/Chassis
Vibration test (standard/ruggedized)	0.7 g/1.0 g
Relative humidity	5%-95% (IEC 721-3-3; Class 3K3 (non-condensing) during operation)
Aggressive environment (IEC 60068-2-43) H ₂ S test	Class Kd
Aggressive gases (IEC 60721-3-3)	Class 3C3
Test method according to IEC 60068-2-43	H2S (10 days)
Ambient temperature (at SFAVM switching mode)	
- with derating	Maximum 55° C (131° F) ⁽¹⁾
- with full output power of typical EFF2 motors (up to 90% output current)	Maximum 50° C (122° F) ⁽¹⁾
- at full continuous FC output current	Maximum 45° C (113° F) ⁽¹⁾
Minimum ambient temperature during full-scale operation	0° C (32° F)
Minimum ambient temperature at reduced speed performance	-10° C (14° F)
Temperature during storage/transport	-25 to +65/70° C (-13 to +149/158° F)
Maximum altitude above sea level without derating	1000 m (3281 ft)
Maximum altitude above sea level with derating ⁽²⁾	3000 m (9842 ft)
EMC standards, Emission	EN 61800-3
EMC standards, Immunity	EN 61800-3
Energy efficiency class	IE2 ⁽¹⁾

¹ Determined according to EN 50598-2 at:

- Rated load.
- 90% rated frequency.
- Switching frequency factory setting.
- Switching pattern factory setting.

² For more information on derating, see *chapter Derating*.

10 Appendix

10.1 Abbreviations

°C	Degrees Celsius
°F	Degrees Fahrenheit
A	Ampere/AMP
AC	Alternating current
AWG	American wire gauge
AMA	Automatic motor adaptation
DC	Direct current
D-TYPE	Drive dependent
EMC	Electro-magnetic compatibility
ETR	Electronic thermal relay
$f_{M,N}$	Nominal motor frequency
FC	Frequency converter
g	Gram
Hz	Hertz
hp	Horsepower
I_{LIM}	Current limit
I_{INV}	Rated inverter output current
$I_{M,N}$	Nominal motor current
$I_{VLT,MAX}$	Maximum output current
$I_{VLT,N}$	Rated output current supplied by the drive
kg	Kilogram
kHz	Kilohertz
LCP	Local control panel
m	Meter
mH	Millihenry inductance
mA	Milliampere
ms	Millisecond
min	Minute
MCT	Motion control tool
nF	Nanofarad
Nm	Newton meter

n_s	Synchronous motor speed
$P_{M,N}$	Nominal motor power
PELV	Protective extra low voltage
PCB	Printed circuit board
PM motor	Permanent magnet motor
Regen	Regenerative terminals
RPM	Revolutions per minute
s	Second
T_{LIM}	Torque limit
$U_{M,N}$	Nominal motor voltage
V	Volts

10.2 Definitions

10.2.1 AC Drive

Coast

The motor shaft is in free mode. No torque on the motor.

$I_{VLT,MAX}$

Maximum output current.

$I_{VLT,N}$

Rated output current supplied by the drive.

$U_{VLT,MAX}$

Maximum output voltage.

10.2.2 Input

Control commands

Start and stop the connected motor with LCP and digital inputs.

Functions are divided into 2 groups.

Functions in group 1 have higher priority than functions in group 2.

Table 91: Function Groups

Group 1	Reset, coast stop, reset and coast stop, quick stop, DC brake, stop, and [Off].
Group 2	Start, pulse start, reversing, start reversing, jog, and freeze output.

10.2.3 Motor

Motor running

Torque generated on the output shaft and speed from 0 RPM to maximum speed on the motor.

f_{JOG}

Motor frequency when the jog function is activated (via digital terminals or bus).

f_M

Motor frequency.

f_{MAX}

Maximum motor frequency.

f_{MIN}

Minimum motor frequency.

$f_{M,N}$
Rated motor frequency (nameplate data).

I_M
Motor current (actual).

$I_{M,N}$
Nominal motor current (nameplate data).

$n_{M,N}$
Nominal motor speed (nameplate data).

n_s
Synchronous motor speed.

$$n_s = \frac{2 \times \text{Parameter 1-23} \times 60 \text{ s}}{\text{Parameter 1-39}}$$

n_{slip}
Motor slip.

$P_{M,N}$
Rated motor power (nameplate data in kW or hp).

$T_{M,N}$
Rated torque (motor).

U_M
Instantaneous motor voltage.

$U_{M,N}$
Rated motor voltage (nameplate data).

Break-away torque

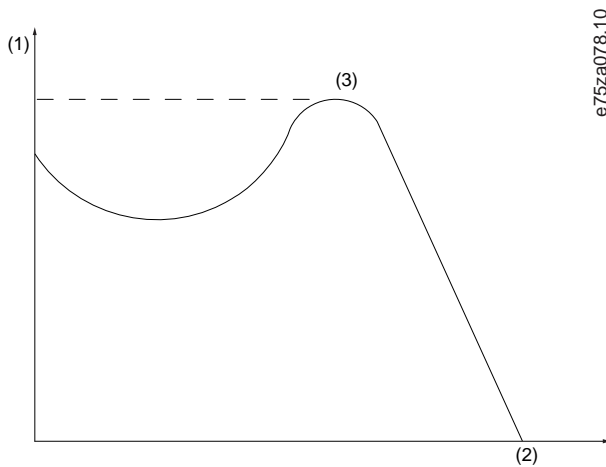

Illustration 82: Break-away Torque

1	Torque	3	Pull-out
2	RPM		

η_{VLT}
The efficiency of the drive is defined as the ratio between the power output and the power input.

Start-disable command

A start-disable command belonging to the control commands in group 1. See the table in chapter Input for more details.

Stop command

A stop command belonging to the control commands in group 1. See the table in chapter Input for more details.

10.2.4 References

Analog reference

A signal transmitted to the analog inputs 53 or 54 can be voltage or current.

- Current input: 0–20 mA and 4–20 mA
- Voltage input: 0–10 V DC

Bus reference

A signal transmitted to the serial communication port (FC port).

Binary reference

A signal transmitted via the serial communication port.

Preset reference

A defined preset reference to be set from -100% to +100% of the reference range. Selection of 8 preset references via the digital terminals. Selection of 4 preset references via the bus.

Ref_{MAX}

Determines the relationship between the reference input at 100% full scale value (typically 10 V, 20 mA) and the resulting reference. The maximum reference value is set in *parameter 3-03 Maximum Reference*.

Ref_{MIN}

Determines the relationship between the reference input at 0% value (typically 0 V, 0 mA, 4 mA) and the resulting reference. The minimum reference value is set in *parameter 3-02 Minimum Reference*.

10.2.5 Miscellaneous

Analog inputs

The analog inputs are used for controlling various functions of the drive.

There are 2 types of analog inputs:

- Current input: 0–20 mA and 4–20 mA.
- Voltage input: 0–10 V DC.

Analog outputs

The analog outputs can supply a signal of 0–20 mA, 4–20 mA, or a digital signal.

Automatic motor adaptation, AMA

The AMA algorithm determines the electrical parameters for the connected motor at standstill and compensates for the resistance based on the length of the motor cable.

Digital inputs

The digital inputs can be used for controlling various functions of the drive.

Digital outputs

The drive features 2 solid-state outputs that can supply a 24 V DC (maximum 40 mA) signal.

DSP

Digital signal processor.

Relay outputs

The drive provides 2 programmable relay outputs.

ETR

Electronic thermal relay is a thermal load calculation based on present load and time. Its purpose is to estimate the motor temperature and prevent overheating of the motor.

Initializing

If initializing is carried out (*parameter 14-22 Operation Mode*), the drive returns to the default setting.

Parameter 14-22 Operation Mode does not initialize communication parameters, fault log, or fire mode log.

Intermittent duty cycle

An intermittent duty rating refers to a sequence of duty cycles. Each cycle consists of an on-load and an off-load period. The operation can be either periodic duty or nonperiodic duty.

LCP

The local control panel makes up a complete interface for control and programming of the drive. The LCP is detachable. With the installation kit option, the LCP can be installed up to 3 m (9.8 ft) from the drive in a front panel.

NLCP

The numerical local control panel interface for control and programming of the drive. The display is numerical and the panel is used to show process values. The NLCP has storing and copy functions.

GLCP

The graphic local control panel interface for control and programming of the drive. The display is graphic and the panel is used to show process values. The GLCP has storing and copy functions.

lsb

Least significant bit.

msb

Most significant bit.

MCM

Short for mille circular mil, an American measuring unit for cable cross-section. 1 MCM = 0.5067 mm².

On-line/off-line parameters

Changes to on-line parameters are activated immediately after the data value is changed. To activate changes to offline parameters, press [OK].

PI controller

The PI controller maintains the desired speed, pressure, temperature, and so on, by adjusting the output frequency to match the varying load.

Process PID

The PID control maintains speed, pressure, and temperature by adjusting the output frequency to match the varying load.

PCD

Process control data.

PFC

Power factor correction.

Power cycle

Switch off the mains until the display (LCP) is dark, then turn power on again.

Power factor

The power factor is the relation between I_1 and I_{RMS} , where I_1 is the fundamental current, and I_{RMS} is the total RMS current including harmonic currents.

$$\text{Power factor} = \frac{\sqrt{3} \times U \times I_1 \cos\phi_1}{\sqrt{3} \times U \times I_{RMS}}$$

For VLT® Flow Drive FC 111 drives, $\cos\phi_1 = 1$, therefore:

$$\text{Power factor} = \frac{I_1 \times \cos\phi_1}{I_{RMS}} = \frac{I_1}{I_{RMS}}$$

The power factor indicates to which extent the drive imposes a load on the mains supply. The lower the power factor, the higher the I_{RMS} for the same kW performance.

$$I_{RMS} = \sqrt{I_1^2 + I_5^2 + I_7^2 + \dots + I_n^2}$$

In addition, a high power factor indicates that the different harmonic currents are low.

The built-in DC coils produce a high-power factor, minimizing the imposed load on the mains supply.

Pulse input/incremental encoder

An external, digital pulse transmitter used for feeding back information on motor speed. The encoder is used in applications where great accuracy in speed control is required.

RCD

Residual current device.

Set-up

Save parameter settings in 2 set-ups. Change between the 2 parameter set-ups and edit 1 set-up while another set-up is active.

SFAVM

Acronym describing the switching pattern stator flux-oriented asynchronous vector modulation.

Slip compensation

The drive compensates for the motor slip by giving the frequency a supplement that follows the measured motor load, keeping the motor speed almost constant.

Smart logic control (SLC)

The SLC is a sequence of user-defined actions executed when the smart logic controller evaluates the associated user-defined events as true.

STW

Status word.

THD

Total harmonic distortion states the total contribution of harmonic distortion.

Thermistor

A temperature-dependent resistor placed where the temperature is monitored (drive or motor).

Trip

Trip is a state entered in fault situations. Examples of fault situations:

- The drive is subject to an over voltage.
- The drive protects the motor, process, or mechanism.

Restart is prevented until the cause of the fault has disappeared, and the trip state is canceled by activating reset or, in some cases, by being programmed to reset automatically. Do not use trip for personal safety.

Trip lock

Trip lock is a state entered in fault situations when the drive is protecting itself and requiring physical intervention. For example, a short circuit on the output triggers a trip lock. A locked trip can only be canceled by cutting off mains, removing the cause of the fault, and reconnecting the drive. Restart is prevented until the trip state is canceled by activating reset or, sometimes, by being programmed to reset automatically. Do not use trip lock for personal safety.

VT characteristics

Variable torque characteristics used for pumps and fans.

VVC⁺

If compared with standard voltage/frequency ratio control, voltage vector control (VVC⁺) improves the dynamics and stability, both when the speed reference is changed and in relation to the load torque.

60° AVM

Refer to the switching pattern 60° asynchronous vector modulation.

Index

A	
Abbreviations.....	138
AC mains.....	73
Accessory.....	50
Acoustic noise.....	30
Additional resource.....	10
ADR.....	106
Aggressive environments.....	31
Air humidity.....	30
AK.....	107, 108
AMA.....	141
Ambient conditions (H13–H14).....	137
Ambient conditions (H1–H8).....	136
Ambient temperature.....	61
Analog input.....	134, 141, 141
Analog output.....	141
Application examples.....	20
Automatic derating.....	60
B	
Back-channel cooling.....	59
Balancing contractor.....	24
BCC.....	106
Better control.....	18
Branch circuit protection.....	73
Break-away torque.....	140
Building management system, BMS.....	15
Burst transient.....	72
Bypass frequency range.....	22
C	
Cables	
Leakage current.....	39
CAV.....	21
CE compliance.....	74
CE mark.....	10
Central VAV system.....	20
Centrifugal pumps.....	60
Changes made.....	82
Check valve monitoring.....	26
Circuit breaker.....	40, 73
Coast.....	126, 139
Comparison, energy saving.....	15
Condenser pump.....	23
Constant air volume.....	21
Constant torque.....	60
Control input/output.....	135, 136
Control potential.....	25
Control shelf.....	69
Control structure closed loop.....	28
Control structure open loop.....	27
Control word.....	125
Controlling fan.....	14
Controlling pump.....	14
Conversion.....	109
Conversion factor.....	109
Conversion index.....	109
Cooling.....	56
Cooling tower fan.....	22
CT mode.....	60
Current	
Leakage current.....	38
Transient ground.....	40
Current loop.....	32
D	
Damper.....	20
Data control byte.....	106
Data field.....	106
Data types.....	109
DC brake.....	126
DC voltage output, 10 V.....	136
DC voltage output, 24 V.....	135
Decoupling plate.....	48
Definition of EMC categories.....	32
Derating	
Low-speed operation.....	60
Differential pressure.....	25
Digital input.....	134
Digital output.....	135
Display.....	81
Document version.....	10
Drive address.....	106
Drive closed-loop controller, tuning.....	29
Dry pump detection.....	26
E	
Earth leakage circuit breaker.....	40
See Residual current device	
Efficiency of the drive.....	76
Efficiency of the motor.....	77
Efficiency of the system.....	77
Electrical installation.....	70
Electronic thermal relay.....	141
EMC	
Directive.....	11
EMC plan.....	32
EMC-compliant installation.....	64
Emission.....	31
Emission requirement.....	32, 32
EN 61800-3.....	137
End of curve detection.....	26
Energy efficiency class.....	137, 137
Energy saving.....	14, 15, 17
Environment	
Industrial.....	32
Residential.....	32
ErP directive.....	11
ETR.....	42, 141
Evaporator flow rate.....	24
Extreme running condition.....	41
F	
Fans.....	60
Feedback conversion.....	28
Flow meter.....	24
Force/write multiple coil (0F hex).....	121
Force/write single coil (05 hex).....	120
Freeze output.....	139
Function Codes.....	117

Fuse.....	73	Modbus communication.....	103
G		Modbus exception codes.....	118
Galvanic isolation.....	37	Modbus RTU.....	104, 111, 112, 117
GLCP.....	142	Modbus RTU commands.....	119
Ground		Modbus RTU protocol.....	111
Leakage protection.....	31	Moment of inertia.....	41
Leakage current.....	39	Motor	
H		Cable.....	31
Hardware Set-up.....	102	Leakage current.....	39
Harmonic current.....	34	Thermal protection.....	42,130
Harmonics distortion.....	31	Low-speed operation.....	60
Harmonics emission.....	34	Connection.....	73
Harmonics emission requirement.....	34, 34	Overload protection.....	133
Harmonics test result (emission).....	35, 36	Output.....	133
High altitudes.....	60	Motor-generated overvoltage.....	41
Hold output frequency.....	127	Mounting.....	56
I		Multiple pump.....	25
IEC 60068-2-43.....	137	N	
IEC 721-3-3.....	137	Navigation key.....	82
IGV.....	20	Network configuration.....	112
Immunity requirement.....	32, 37	Network connection.....	102
IND.....	108	NLCP.....	141
Index.....	108	Nominal motor current.....	140
Indexed parameters.....	99	Nominal motor speed.....	140
Indicator light.....	82, 82	O	
Industrial environment.....	32, 33	Operation key.....	82
Installation		Option.....	50
Qualified personnel.....	12	Overcurrent protection.....	74
Tools required.....	56	P	
Intermediate circuit.....	41	Parameter block.....	106
Intermittent duty cycle.....	141	Parameter number.....	108
IP21 enclosure kit.....	46	Parameter value.....	108
Isolated main.....	73	Payback period.....	17
J		PCD.....	106, 110
Jog.....	127, 139	PELV.....	37
L		PKE field.....	107
LCP.....	27, 81, 98, 139, 141	PNU.....	107, 108, 118
Leakage current.....	13, 31, 38, 72, 72	Potential equalization.....	72
LGE.....	105	Power cycle.....	142
Lifting.....	56, 57	Preset multiple register (10 hex).....	123
Local (hand on) control.....	27	Preset single register (06 hex).....	122
Local control panel.....	81	Primary pump.....	24
Local speed determination.....	24	Process block.....	106
Low air pressure.....	60	Process words.....	110
Low evaporator temperature.....	24	Programmable minimum frequency setting.....	22
Low voltage directive.....	11	Programming.....	81
M		Protective extra low voltage.....	37
Main menu.....	98	Public supply network.....	34, 34
Mains drop-out.....	42	Pump impeller.....	23
Mains supply.....	133	Purpose of the manual.....	10
Manual derating.....	60	PWE.....	108
Manual PI adjustment.....	29	Q	
MCT 10 setup software.....	10, 81	Qualified personnel.....	12
Menu key.....	81	Quick menu.....	82
		Quick transfer.....	98

R		Telegram structure.....	105
Rated current.....	32	Text block.....	106
RCD.....	142	THD.....	34
Read coil status (01 hex).....	119	Throttling valve.....	23
Read holding registers (03 hex).....	122	Tightening torques.....	70
Read/Write multiple registers (17 hex).....	124	Time-based functions.....	26
Recommended initialization.....	99, 99	Tools.....	56
Reference handling.....	28	Total voltage distortion.....	34
Relay output.....	135	Trip.....	143
Remote (auto on) control.....	27	Trip lock.....	143
Remote terminal unit.....	111	Two-finger initialization.....	99, 99
Residential environment.....	32, 33	Type code.....	45
Residual current device.....	40		
RS485.....	101, 104, 135	V	
		Variable air volume.....	20
S		Variable control, flow and pressure.....	18
Secondary pump.....	25	Variable torque.....	60
Serial communication.....	141	Varying flow (1 year).....	17
Shock.....	31	VAV.....	20
Short circuit (motor phase-phase).....	41	Vibration.....	22, 31
Short-circuit protection.....	73	Voltage	
Side-by-side installation.....	55	Safety warning.....	12
Slip compensation.....	142	Voltage distortion.....	34
Soft starter.....	18	VT mode.....	60
Software version.....	10		
Star/delta starter.....	18	W	
Status menu.....	82	Wire size.....	73
Status word.....	128	Wiring schematic.....	64
Switching frequency		Wizard	
Use with RCDs.....	40	Open-loop application.....	82
Switching on the output.....	41	Closed-loop application.....	82
Symbols.....	12	Motor set-up.....	82
Synchronous motor speed.....	140		
T			
Telegram length.....	105		

Danfoss A/S
Ulsnaes 1
DK-6300 Graasten
vlt-drives.danfoss.com

Danfoss can accept no responsibility for possible errors in catalogs, brochures, and other printed material. Danfoss reserves the right to alter its products without notice. This also applies to products already on order provided that such alterations can be made without subsequential changes being necessary in specifications already agreed. All trademarks in this material are property of the respective companies. Danfoss and the Danfoss logotype are trademarks of Danfoss A/S. All rights reserved.

