

Installation Guide

VLT® Programmable I/O MCB 115
VLT® HVAC Drive FC 102, VLT® Refrigeration
Drive FC 103, VLT® AutomationDrive FC 301/302

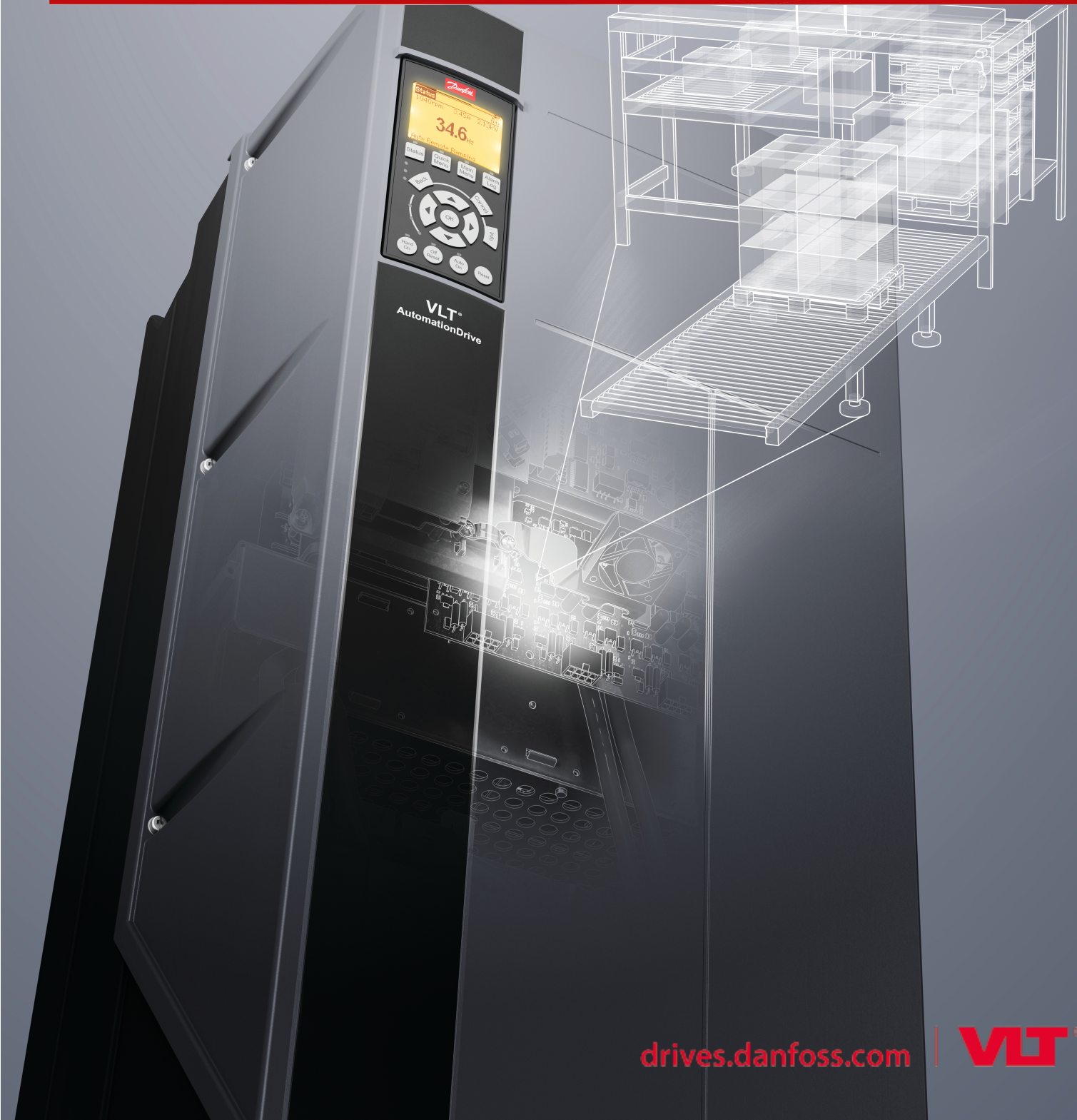

Contents

1	Introduction	4
1.1	Purpose of this Installation Guide	4
1.2	Trademarks	4
1.3	Document Version	4
1.4	Additional Resources	4
1.5	Product Overview	4
1.5.1	Intended Use	4
1.5.2	Foreseeable Misuse	5
1.5.3	Items Supplied	5
2	Safety	6
2.1	Safety Symbols	6
2.2	Qualified Personnel	6
2.3	Safety Precautions	7
3	Installation	8
3.1	Safety Instructions	8
3.2	Mounting the Option in Enclosure Sizes A2, A3, and B3	8
3.3	Mounting the Option in Enclosure Sizes A5, B1, B2, B4, C, D, E, and F	9
3.4	Electrical Installation	10
3.4.1	Specifications	10
3.4.1.1	Programmable Inputs	11
3.4.1.2	Programmable Outputs	12
3.4.1.3	Terminals	13
4	Appendix	14
4.1	Abbreviations	14
4.2	Conventions	14

1 Introduction

1.1 Purpose of this Installation Guide

This manual provides information for safe installation of a VLT® Programmable I/O MCB 115 option used in the VLT® FC drive series.

The installation guide is intended for use by qualified personnel only. Personnel must be familiar with the VLT® FC drive series.

Read and follow the instructions before installation, and ensure that instructions for safe installation are observed. Always keep these instructions available with the drive.

1.2 Trademarks

VLT® is a registered trademark for Danfoss A/S.

1.3 Document Version

This manual is regularly reviewed and updated. All suggestions for improvement are welcome. See document version and changes applied in [table 1](#).

The original language of this manual is English.

Table 1: Version and Changes Applied

Revision date	Remarks
2019.10	Option now also applicable for VLT® HVAC Drive FC 102 and VLT® Refrigeration Drive FC 103.

1.4 Additional Resources

More information resources are available to understand advanced drive functions and programming.

- The VLT® FC Series Operating Guides provide information required to install and commission the drive for given applications.
- The VLT® FC Series Programming Guides provide greater detail on working with parameters.
- VLT® FC Series Design Guides provide detailed capabilities and functionality to design motor control systems for various applications.

Technical documentation for other product options is available at www.danfoss.com.

1.5 Product Overview

1.5.1 Intended Use

The VLT® Programmable I/O MCB 115 is intended to:

- Extend the I/O selection available on the control card, for example, for multi-zone control with 3 pressure transmitters.
- Turn the AC drive into a decentralized I/O block supporting building automation systems with inputs and outputs.
- Support the extended PI controllers with I/Os for setpoint inputs, transmitter/sensor inputs, and outputs for actuators.
- Provide a digital output used for:
 - Driving a relay.
 - Input to commonly used PLC I/O boards.
 - Input to another AC drive in a sequentially controlled application.

The VLT® Programmable I/O MCB 115 is intended for use only with:

- VLT® HVAC Drive FC 102
- VLT® Refrigeration Drive FC 103
- VLT® AutomationDrive FC 301
- VLT® AutomationDrive FC 302

NOTICE

The VLT® Programmable I/O MCB 115 is only functional if it is built into the drive. The option cannot be used as a standalone.

1.5.2 Foreseeable Misuse

Any use not expressly approved by Danfoss constitutes misuse. This also applies to failure to comply with the specified operating conditions and applications.

Danfoss assumes no liability of any sort for damage attributable to improper use.

1.5.3 Items Supplied

When the VLT® Programmable I/O MCB 115 is not factory mounted, the following items are supplied:

- VLT® Programmable I/O MCB 115 B-option with coated PCB, order number 130B1266.
- LCP cradle
- Front cover
- Stickers for front cover
- Installation Guide

2 Safety

2.1 Safety Symbols

The following symbols are used in this manual:

⚠ DANGER ⚠

Indicates a hazardous situation which, if not avoided, will result in death or serious injury.

⚠ WARNING ⚠

Indicates a hazardous situation which, if not avoided, could result in death or serious injury.

⚠ CAUTION ⚠

Indicates a hazardous situation which, if not avoided, could result in minor or moderate injury.

NOTICE

Indicates information considered important, but not hazard-related (for example messages relating to property damage).

2.2 Qualified Personnel

The products must only be assembled, installed, programmed, commissioned, maintained, and decommissioned by persons with proven skills. Persons with proven skills:

- Are qualified electrical engineers, or persons who have received training from qualified electrical engineers and are suitably experienced to operate devices, systems, plant, and machinery in accordance with the general standards and guidelines for safety technology.
- Are familiar with the basic regulations concerning health and safety/accident prevention.
- Have read and understood the safety guidelines given in this manual and also the instructions given in the operating guide of the drive.
- Have good knowledge of the generic and specialist standards applicable to the specific application.

2.3 Safety Precautions

⚠ WARNING ⚠

UNINTENDED START

When the drive is connected to the AC mains, DC supply, or load sharing, the motor may start at any time, causing risk of death, serious injury, and equipment or property damage. The motor may start by activation of an external switch, a fieldbus command, an input reference signal from the LCP or LOP, via remote operation using MCT 10 Set-up software, or after a cleared fault condition.

- Press [Off] on the LCP before programming parameters.
- Disconnect the drive from the mains whenever personal safety considerations make it necessary to avoid unintended motor start.
- Check that the drive, motor, and any driven equipment are in operational readiness.

⚠ WARNING ⚠

LACK OF SAFETY AWARENESS

This document gives important information on how to prevent injury and damage to the equipment or the system. Ignoring them can lead to death, serious injury, or severe damage to the equipment.

- Make sure to fully understand the dangers and safety measures incurred in the application.

3 Installation

3.1 Safety Instructions

⚠ WARNING ⚠

DISCHARGE TIME

The drive contains DC-link capacitors, which can remain charged even when the drive is not powered. High voltage can be present even when the warning indicator lights are off.

Failure to wait the specified time after power has been removed before performing service or repair work could result in death or serious injury.

- Stop the motor.
- Disconnect AC mains, permanent magnet type motors, and remote DC-link supplies, including battery back-ups, UPS, and DC-link connections to other drives.
- Wait for the capacitors to discharge fully before performing any service or repair work. The discharge time is specified in the drive operating guides.
- Use a measuring device to make sure that there is no voltage, before opening the drive or performing any work on the cables.

⚠ WARNING ⚠

BEFORE INSTALLATION/REPAIR

The operator or electrical installer is responsible for compliance with all applicable national and local safety regulations. Not following national and local regulations may lead to personal injury.

- Disconnect all electric power, including remote disconnects, and discharge all motor start/run capacitors before servicing.
- To ensure that the power cannot be inadvertently energized, follow proper lock-out/tag-out procedures.

For more safety information, see [2 Safety](#) and the relevant drive operating guide. Also, always observe the instructions provided by the motor manufacturer.

3.2 Mounting the Option in Enclosure Sizes A2, A3, and B3

Context:

The installation procedure depends on the enclosure size of the drive. This procedure is for installation in enclosure sizes A2, A3, and B3.

Procedure

1. Remove the LCP, the terminal cover, and the LCP frame from the drive.
2. Fit the option into slot B.
3. Connect the control cables and relieve the cable. See [3.4.1 Specifications](#) for wiring details.
4. Remove the knockouts in the extended LCP frame (supplied).
5. Fix the extended LCP frame and terminal cover on the drive.
6. Fit the LCP or blind cover in the extended LCP frame.
7. Connect power to the drive.
8. Set up the input/output functions in the corresponding parameters.

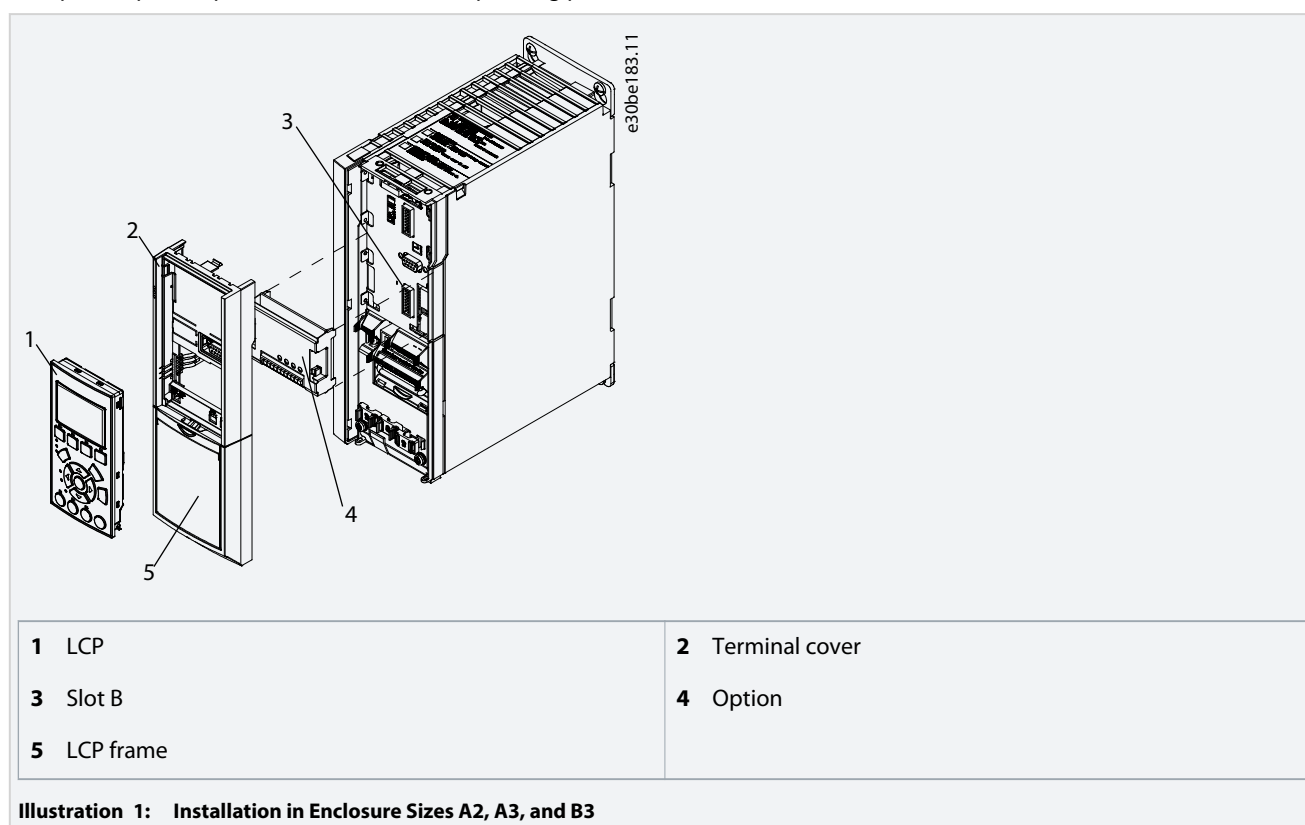

3.3 Mounting the Option in Enclosure Sizes A5, B1, B2, B4, C, D, E, and F

Context:

The installation procedure depends on the enclosure size of the drive. This procedure is for installation in enclosure sizes A5, B1, B2, B4, C, D, E, and F.

Procedure

1. Remove the LCP and the LCP cradle.
2. Fit the option card into slot B.
3. Connect the control cables and relieve the cable. See [3.4.1 Specifications](#) for wiring details.
4. Fit the cradle on the drive.
5. Fit the LCP in the cradle.

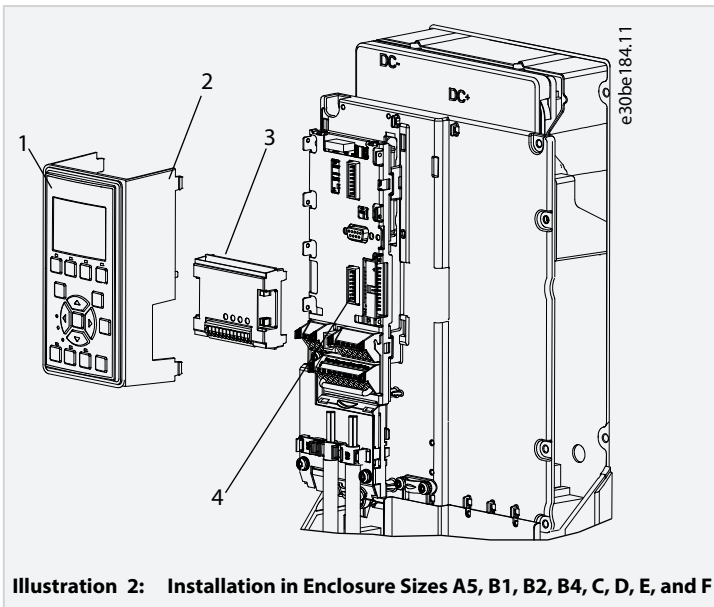

3.4 Electrical Installation

3.4.1 Specifications

The VLT® Programmable I/O MCB 115 has 3 programmable inputs/outputs, which extend the number of inputs and outputs for the drive.

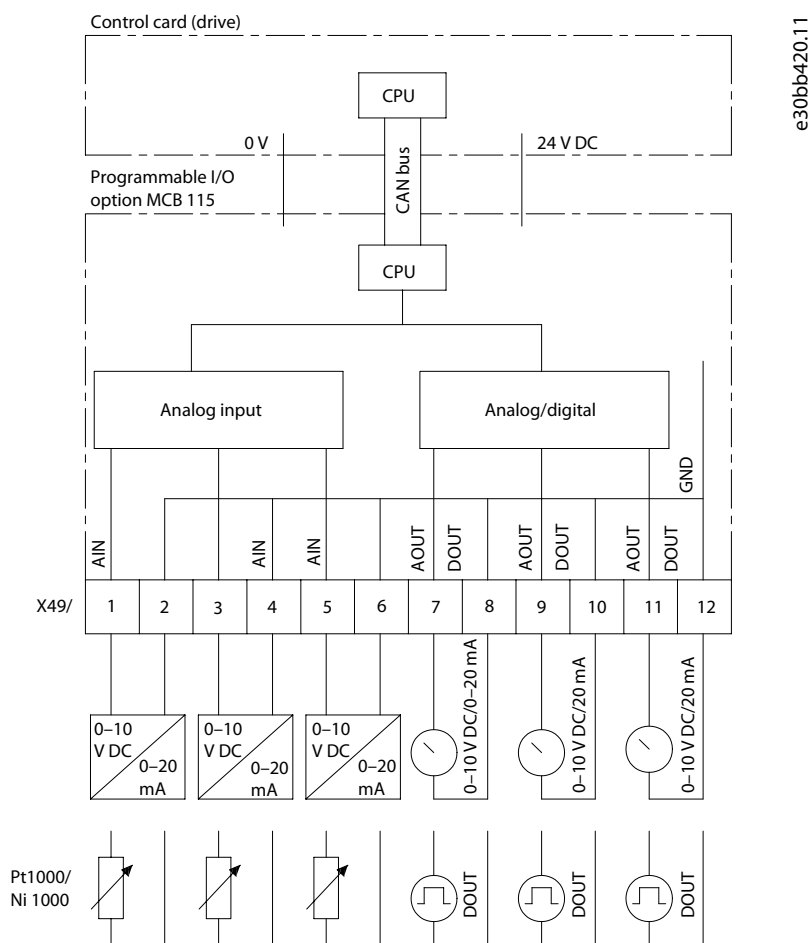

e30bb420.11

Illustration 3: Input and Output Block Diagram

3.4.1.1 Programmable Inputs

The analog inputs can be used for reference or process feedback for PID controllers. They can work as:

- Analog voltage inputs.
- Analog current inputs.
- Analog temperature inputs.

Table 2: Programmable Inputs

	Used as temperature sensor input	Used as analog voltage input	Used as current input
Number of inputs	3	3	3
Terminal	X49/1-6	X49/1-6	X49/1-6
Voltage/current range	-	0-10 V DC or 2-10 V DC	0-20 mA or 4-20 mA

	Used as temperature sensor input	Used as analog voltage input	Used as current input
Temperature sensor (1000 Ω at 0 °C (32 °F))	Ni1000 (according to DIN 43760)	–	–
	Pt1000 (according to IEC 60751)	–	–
Accuracy	-50 °C ±1 Kelvin +150 °C ±2 Kelvins	Better than 1% of full scale	Better than 1% of full scale
Temperature range	-50 °C (-58 °F) to +150 °C (+302 °F)	–	–
Resolution [bits]	10	10	10
Sampling [Hz]	3	Minimum 2	Minimum 2
Maximum load	–	±28 V continuously	±29 mA continuously
Impedance	–	10 kΩ	200 Ω

NOTICE

- Maximum cable length for temperature sensors is 50 m (164 ft) non-shielded/non-twisted wires.
- Keep cable impedance low as every 3.85 Ω in cables gives a misreading of 1 Kelvin.

3.4.1.2 Programmable Outputs

The 3 programmable outputs can work as:

- analog voltage outputs.
- analog current outputs.
- digital outputs.

Table 3: Programmable Outputs

	Used as digital output	Used as analog voltage output	Used as current output
Number of outputs	3	3	3
Terminal	X49/7–12	X49/7–12	X49/7–12
Voltage/current range	<ul style="list-style-type: none"> • Maximum voltage at low output: 4 V • Minimum voltage at high output: 20 V • Maximum output current: 24 mA 	0–10 V DC	0–20 mA
Accuracy	–	Better than ±1%	Better than ±1%
Resolution [bits]	–	10	10
Maximum load	–	±28 V continuously	±29 mA continuously
Load impedance	–	≥10 kΩ	≤200 Ω

3.4.1.3 Terminals

There are 3 inputs and 3 outputs on the option:

- Inputs: X49/1+2, X49/3+4, and X49/5+6
- Outputs: X49/7+8, X49/9+10, and X49/11+12

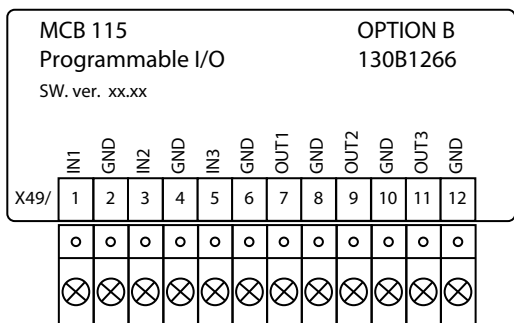

e30bt125.12

Illustration 4: Terminal X49

4 Appendix

4.1 Abbreviations

I/O	Input/output
LCP	Local control panel
LOP	Local operation panel
PLC	Programmable logic controller

4.2 Conventions

- Numbered lists indicate procedures.
- Bulleted and dashed lists indicate listings of other information where the order of the information is not relevant.
- Bolded text indicates highlighting and section headings.
- Italicized text indicates the following:
 - Cross-reference.
 - Link.
 - Footnote.
 - Parameter name.
 - Parameter option.
 - Parameter group name.
- All dimensions in drawings are in metric values (imperial values in brackets).
- An asterisk (*) indicates the default setting of a parameter.

ENGINEERING
TOMORROW

Danfoss

.....
Danfoss can accept no responsibility for possible errors in catalogues, brochures and other printed material. Danfoss reserves the right to alter its products without notice. This also applies to products already on order provided that such alterations can be made without subsequential changes being necessary in specifications already agreed. All trademarks in this material are property of the respective companies. Danfoss and the Danfoss logotype are trademarks of Danfoss A/S. All rights reserved.
.....

Danfoss A/S
Ulsnaes 1
DK-6300 Graasten
vlt-drives.danfoss.com

