

VACON® 10
AC DRIVES

QUICK GUIDE

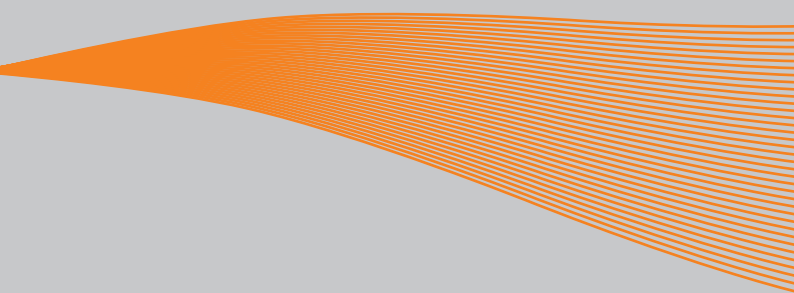

This quick guide includes the steps that enable you to easily install and setup your Vacon 10 frequency converter.

Before putting your drive into operation, download and read the complete Vacon 10 user manual from www.vacon.com -> Downloads

1. SAFETY



THE ELECTRICAL INSTALLATION MAY ONLY BE CARRIED OUT BY A COMPETENT ELECTRICIAN!

This quick guide contains clearly marked warnings that are intended for your personal safety and to prevent any unintentional damage to the product or connected appliances.

Please read these warnings carefully:



The components of the frequency converter's power unit are live when Vacon 10 is connected to the mains. Coming into contact with this voltage is extremely dangerous and may cause death or severe injury.



The motor terminals U, V, W (T1, T2, T3) and brake resistor terminals - / + are live when Vacon 10 is connected to the mains, even if the motor is not running.



The control I/O terminals are isolated from the mains potential. However, the relay output terminals may have a dangerous control voltage even when Vacon 10 is disconnected from the mains.



The earth leakage current of Vacon 10 frequency converters exceeds 3.5 mA AC. A reinforced protective ground connection must be available in accordance with standard EN61800-5-1. **See Chapter 7!**



If the frequency converter is used as part of a machine, the machine manufacturer is responsible for providing the machine with a main switch (EN 60204-1).



If Vacon 10 is disconnected from the mains while the motor is running, Vacon 20 will remain live if the motor is fed by the process. In this case, the motor functions as a generator that feeds energy to the frequency converter.



After disconnecting the frequency converter from the mains, wait until the fan stops and the display segments or status LEDs on the front panel switch off. Wait 5 more minutes before doing any work on Vacon 10 connections.



The motor can start automatically after a fault if the autoreset function is active.

NOTE: English and French product manuals with applicable information on safety, warnings, and cautions can be downloaded from www.vacon.com/downloads.

REMARQUE Vous pouvez télécharger les versions anglaise et française des manuels produit contenant l'ensemble des informations de sécurité, avertissements et mises en garde applicables sur le site www.vacon.com/downloads.

2. INSTALLATION

2.1 Mechanical installation

There are two possible ways to mount Vacon 10 on the wall, either by screw or DIN rail mounting.

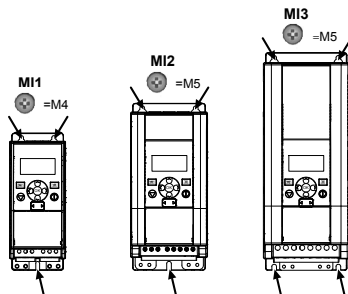

Figure 2.1: Screw mounting, MI1 - MI3

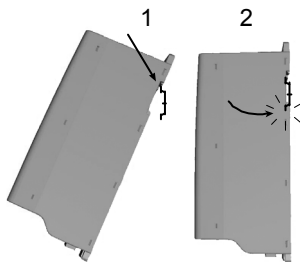

Figure 2.2: DIN rail mounting, MI1 - MI3

Note! See the mounting dimensions on the back of the drive. Leave **free space** for cooling above (**100 mm**), below (**50 mm**), and on the sides (**20 mm**) of Vacon 10! [Side-to-side installation allowed only if the ambient temperature is below 40 °C.]

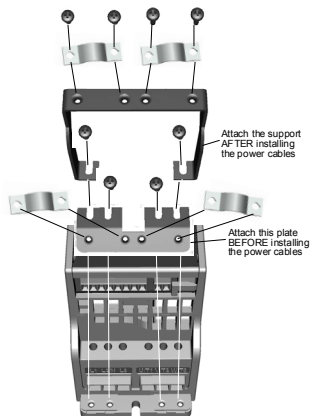

Figure 2.3: Attaching the PE plate and API cable support, MI1 - MI3

2.2 Cabling and connections

2.2.1 Power cabling

Note: The tightening torque for power cables is 0.5 - 0.6 Nm [4-5 In-Lbs].

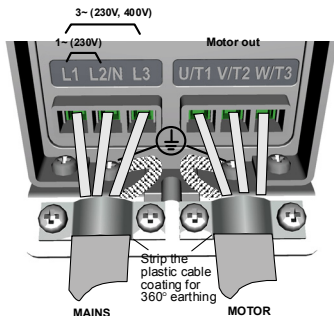

Figure 2.4: Vacon 10 power connections, MI1

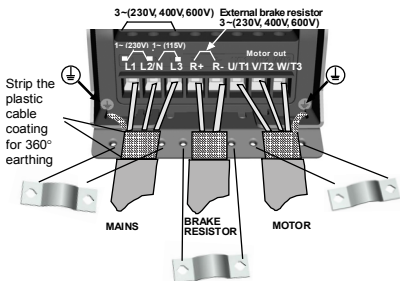

Figure 2.5: Vacon 10 power connections, MI2 - MI3

2.2.2 Control cabling



Figure 2.6: Open the lid (MI1 - MI3)

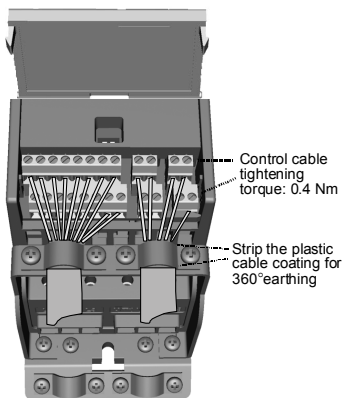
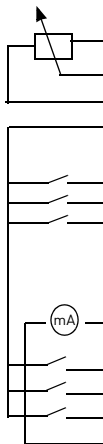

Figure 2.7: Install the control cables (MI1 - MI3)

3. CONTROL I/O AND TERMINALS



Terminal	Signal	Factory preset	Description
1	+10Vref		Ref. voltage out Maximum load 10 mA
2	AI1	Freq. reference ^{P1}	0 - 10 V, Ri = 300 kΩ (min)
3	GND		I/O signal ground
6	24Vout		24V output for DIs ±20 %, max load 50 mA
7	GND		I/O signal ground
8	DI1	Start forward ^{P1}	Positive: Logic1: 8...30V; Logic0: 0...1.5V, Ri = 20KΩ
9	DI2	Start reverse ^{P1}	
10	DI3	Fault reset ^{P1}	
A	A	RS485 signal A	FB Communication Negative
B	B	RS485 signal B	FB Communication Positive
4	AI2	PI actual value ^{P1}	0[4] - 20 mA, Ri ≤ 200Ω
5	GND		I/O signal ground
13	GND		I/O signal ground
14	DI4	Preset speed B0 ^{P1}	Positive: Logic1: 8...30V; Logic0: 0...1.5V, Ri = 20KΩ
15	DI5	Preset speed B1 ^{P1}	
16	DI6	External fault ^{P1}	
18	A0	Output frequency ^{P1}	0[4] - 20 mA, RL ≤ 500Ω
20	DO	Active = READY ^{P1}	Open collector, max load 35V/50mA
22	R01 NO	Relay out 1	Active = RUN ^{P1}
23	R01 CM		
24	R02 NC	Relay out 2	Active = FAULT ^{P1}
25	R02 CM		
26	R02 NO		

Table 3.1: Vacon 10 default I/O configuration and connections
^{P1} = Programmable function; see parameter lists and descriptions, chapters 5.

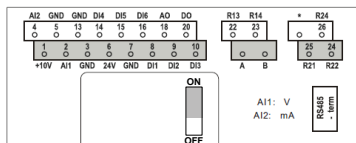

Figure 3.1: Vacon 10 I/O

4. NAVIGATION AND STARTUP

4.1 The main menus of Vacon 10

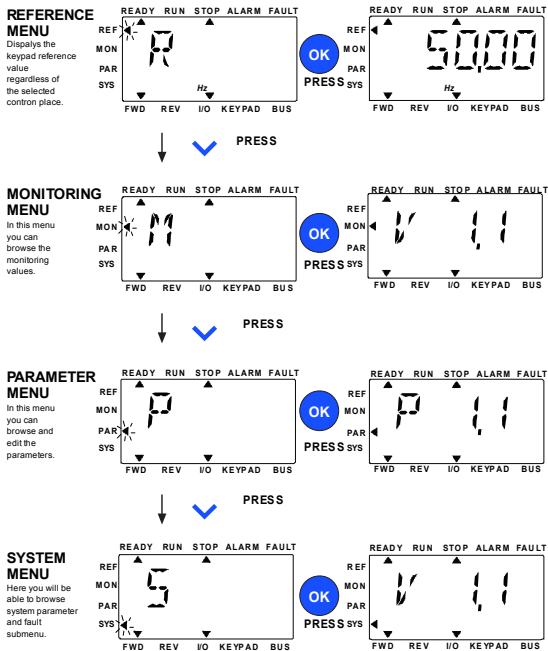

Figure 4.1: The main menu of Vacon 10

4.2 Putting into operation and startup wizard

4.2.1 Steps to put the drive into operation:

1. Read the safety instructions on page 1	7. Perform the test run without the motor ; see the User Manual at www.vacon.com
2. Secure the grounding and check that cables comply with requirements	8. Run no-load tests without the motor connected to the process
3. Check the quality and quantity of the cooling air	9. Perform an identification run (Par. ID631)
4. Check that all start/stop switches are in the STOP position	10. Connect the motor to the process and perform the test run again
5. Connect the drive to the mains	11. Vacon 10 is now ready for use
6. Run the startup wizard and set all necessary parameters	

Table 4.1: Steps to put the drive into operation

4.2.2 Startup wizard

Vacon 10 runs the startup wizard when the machine is powered up for the first time. The wizard is run by setting SYS Par.4.2 =1. The following figures show the procedure.

NOTE: Running the startup wizard always returns all parameters to their factory default settings.

NOTE: StartUp-Wizard can be skipped after pressing the STOP button continuously for 30 seconds

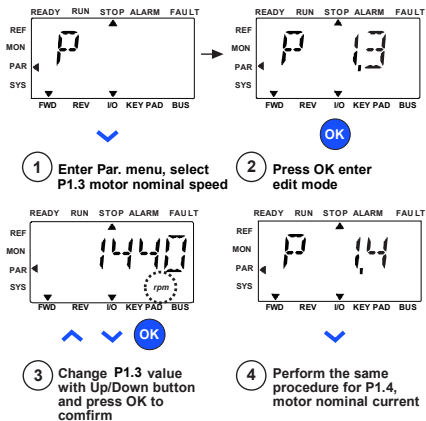
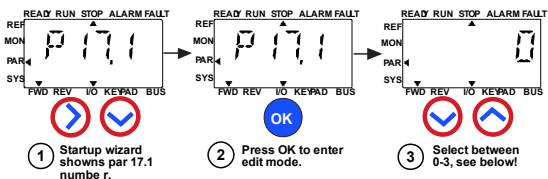

Figure 4.2: Vacon 10 startup wizard (standard application)

Selections:

	P1.7	P1.8	P1.15	P2.2	P2.3	P3.1	P4.2	P4.3
0 = Basic	1.5 x INMOT	0= Frequency control	0= Not used	0= Ramp	0= Coast	0 Hz	3s	3s
1 = Pump drive	1.1 x INMOT	0= Frequency control	0= Not used	0= Ramp	1= Ramp	20 Hz	5s	5s
2 = Fan drive	1.1 x INMOT	0= Frequency control	0= Not used	1= Flying	0= Coast	20 Hz	20s	20s
3 = High Torque drive	1.5 x INMOT	1=Open loop speed control	1= used	0= Ramp	0= Coast	0 Hz	1s	1s

Parameters affected:

P1.7 Current limit (A)
 P1.8 Motor control mode
 P1.15 Torque boost
 P2.2 Start function
 P2.3 Stop function
 P3.1 Min frequency
 P4.2 Acc. time (s)
 P4.3 Dec time (s)

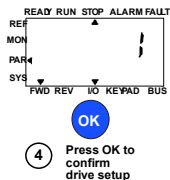

Figure 4.3: Drive setup

5. MONITORING & PARAMETERS

NOTE: This guide is for Vacon 10 standard application, if you need description of parameters in detail, please download the application manual on: www.vacon.com -> downloads.

5.1 Monitoring values

Code	Monitoring signal	Unit	ID	Description
V1.1	Output frequency	Hz	1	Output frequency to motor
V1.2	Frequency reference	Hz	25	Frequency reference to motor control
V1.3	Motor speed	rpm	2	Calculated motor speed
V1.4	Motor current	A	3	Measured motor current
V1.5	Motor torque	%	4	Calculated actual/nominal motor torque
V1.6	Motor Power	%	5	Calculated actual/nominal motor power
V1.7	Motor voltage	V	6	Motor voltage
V1.8	DC link voltage	V	7	Measured DC link voltage
V1.9	Drive temperature	°C	8	Heatsink temperature
V1.10	Motor temperature	%	9	Calculated motor temperature
V2.1	Analog input 1	%	59	A11 signal range as percent of used range
V2.2	Analog input 2	%	60	A12 signal range as percent of used range
V2.3	Analog output	%	81	A0 signal range as percent of used range
V2.4	Digital input status DI1, DI2, DI3		15	Digital input status
V2.5	Digital input status DI4, DI5, DI6		16	Digital input status
V2.6	R01, R02, D0		17	Relay/digital output status
V4.1	PI setpoint	%	20	Regulator setpoint
V4.2	PI feedback value	%	21	Regulator actual value
V4.3	PI error	%	22	Regulator error
V4.4	PI output	%	23	Regulator output

Table 5.1: Vacon 10 monitoring signals

5.2 Quick setup parameters (virtual menu; displays when par. 17.2 = 1)

Code	Parameter	Min	Max	Unit	Default	ID	Note
P1.1	Motor nominal voltage	180	690	V	Varies	110	Check rating plate on motor
P1.2	Motor nominal frequency	30,00	320,00	Hz	50.00 / 60.00	111	Check rating plate on motor
P1.3	Motor nominal speed	30	20000	rpm	1440 / 1720	112	Default applies for a 4-pole motor
P1.4	Motor nominal current	0,2 x I _{Nunit}	2.0 x I _{Nunit}	A	I _{Nunit}	113	Check rating plate on motor
P1.5	Motor cos Φ (Power Factor)	0,30	1,00		0,85	120	Check rating plate on motor
P1.7	Current limit	0,2 x I _{Nunit}	2.0 x I _{Nunit}	A	1.5 x I _{Nunit}	107	Maximum motor current
P1.15	Torque boost	0	1		0	109	0 = Not used 1 = Used
P2.1	Remote control place 1 selection	0	1		0	172	0 = I/O terminal 1 = Fieldbus
P2.2	Start function	0	1		0	505	0 = Ramp 1 = Flying start
P2.3	Stop function	0	1		0	506	0 = Coasting 1 = Ramp
P3.1	Min frequency	0,00	P3.2	Hz	0,00	101	Minimum frequency reference
P3.2	Max frequency	P3.1	320,00	Hz	50.00 / 60.00	102	Maximum frequency reference
P3.3	Remote Control Place 1 frequency reference selection	1	6		4	117	1 = Preset Speed 0 2 = Keypad 3 = Fieldbus 4 = AI1 5 = AI2 6 = PI
P3.4	Preset speed 0	P3.1	P3.2	Hz	5.00	180	Activated by digital inputs
P3.5	Preset speed 1	P3.1	P3.2	Hz	10.00	105	Activated by digital inputs
P3.6	Preset speed 2	P3.1	P3.2	Hz	15.00	106	Activated by digital inputs
P3.7	Preset speed 3	P3.1	P3.2	Hz	20,00	126	Activated by digital inputs

Table 5.2: Quick setup parameters

Code	Parameter	Min	Max	Unit	Default	ID	Note
P4.2	Acceleration time 1	0,1	3000,0	s	3,0	103	Acceleration time from 0 Hz to maximum frequency.
P4.3	Deceleration time 1	0,1	3000,0	s	3,0	104	Deceleration time from maximum frequency to 0 Hz.
P6.1	AI1 Signal range	0	1		0	379	0 = 0 - 100% 1 = 20% - 100% 20% is the same as 2 V minimum signal level.
P6.5	AI2 Signal range	0	1		0	390	0 = 0 - 100% 1 = 20% - 100% 20% is the same as 4 mA minimum signal level.
P14.1	Automatic reset	0	1		0	731	0 = Disable 1 = Enable
P17.2	Parameter conceal	0	1		1	115	0 = All parameters visible 1 = Only quick setup parameter group visible

Table 5.2: Quick setup parameters

5.3 Motor settings (Control panel: Menu PAR -> P1)

Code	Parameter	Min	Max	Unit	Default	ID	Note
P1.1	Motor nominal voltage	180	690	V	Varies	110	Check rating plate on motor
P1.2	Motor nominal frequency	30,00	320,00	Hz	50.00 / 60.00	111	Check rating plate on motor
P1.3	Motor nominal speed	30	20000	rpm	1440 / 1720	112	Default applies for a 4-pole motor
P1.4	Motor nominal current	0,2 x I _{Nunit}	2,0 x I _{Nunit}	A	I _{Nunit}	113	Check rating plate on motor
P1.5	Motor cos Φ (Power Factor)	0,30	1,00		0,85	120	Check rating plate on motor
P1.7	Current limit	0,2 x I _{Nunit}	2,0 x I _{Nunit}	A	1,5 x I _{Nunit}	107	Maximum motor current
P1.8	Motor control mode	0	1		0	600	0 = Frequency control 1 = Open loop speed control
P1.9	U/f ratio	0	2		0	108	0 = Linear 1 = Square 2 = Programmable
P1.10	Field weakening point	8,00	320,00	Hz	50.00 / 60.00	602	Field weakening point frequency
P1.11	Field weakening point voltage	10,00	200,00	%	100,00	603	Voltage at field weakening point as % of U _{nmot}
P1.12	U/f midpoint frequency	0,00	P1.10	Hz	50.00 / 60.00	604	Midpoint frequency for programmable U/f
P1.13	U/f midpoint voltage	0,00	P1.11	%	100,00	605	Midpoint voltage for programmable U/f as % of U _{nmot}
P1.14	Zero freq. voltage	0,00	40,00	%	0,00	606	Voltage at 0 Hz as % of U _{nmot}
P1.15	Torque Boost	0	1		0	109	0 = Disabled 1 = Enabled
P1.16	Switching frequency	1,5	16,0	kHz	4,0/2,0	601	PWM frequency. If values are higher than default, reduce current capacity
P1.17	Brake Chopper	0	2		0	504	0 = Disabled 1 = Enabled: Always 2 = Run state

Table 5.3: Motor settings

Code	Parameter	Min	Max	Unit	Default	ID	Note
P1.19	Motor identification	0	1		0	631	0 = Not active 1 = Standstill identification (need run command within 20 s to activate)
P1.20	Rs voltage drop	0,00	100,00	%	0,00	662	Voltage drop over motor windings as % of $U_{n\text{mot}}$ at nominal current
P1.21	Overtoltage controller	0	2		1	607	0 = Disabled 1 = Enabled, Standard mode 2 = Enabled, Shock load mode
P1.22	Undervoltage controller	0	1		1	608	0 = Disable 1 = Enable
P1.23	Sine filter	0	1		0	522	0 = Not in use 1 = In use
P1.24	Modulator type	0	65535		28928	648	Modulator configuration word: B1 = discontinuous modulation (DPWMMIN) B2 = Pulse dropping in overmodulation B6 = under modulation B8 = instantaneous DC voltage compensation* B11 = Low noise B12 = Dead time compensation* B13 = Flux error compensation* *Enable by default

Table 5.3: Motor settings

NOTE: These parameters display when P17.2 = 0.

5.4 Start/stop setup (Control panel: Menu PAR -> P2)

Code	Parameter	Min	Max	Unit	Default	ID	Note
P2.1	Remote Control Place Selection	0	1		0	172	0 = I/O terminals 1 = Fieldbus
P2.2	Start function	0	1		0	505	0 = Ramp 1 = Flying start
P2.3	Stop function	0	1		0	506	0 = Coasting 1 = Ramp
P2.4	I/O Start/Stop logic	0	3		2	300	I / O control signal 1 I / O control signal 2 0 Forward Reverse 1 Fwd(ledge) Inverted Stop 2 Fwd(ledge) Rev(ledge) 3 Start Reverse
P2.5	Local / Remote	0	1		0	211	0 = Remote control 1 = Local control
P2.6	Keypad control direction	0	1		0	123	0 = Forward 1 = Reverse
P2.9	Keypad button lock	0	1		0	15520	0 = Unlock all keypad button 1 = Lock/Rem button locked

Table 5.4: Start/stop setup

5.5 Frequency references (Control panel: Menu PAR -> P3)

Code	Parameter	Min	Max	Unit	Default	ID	Note
P3.1	Min frequency	0,00	P3.2	Hz	0,00	101	Minimum allowed frequency reference
P3.2	Max frequency	P3.1	320,00	Hz	50.00 / 60.00	102	Maximum allowed frequency reference
P3.3	Remote Control Place frequency reference selection	1	6		4	117	1 = Preset Speed 2 = Keypad 3 = Fieldbus 4 = AI1 5 = AI2 6 = PI
P3.4	Preset speed 0	P3.1	P3.2	Hz	5.00	180	Activated by digital inputs
P3.5	Preset speed 1	P3.1	P3.2	Hz	10.00	105	Activated by digital inputs
P3.6	Preset speed 2	P3.1	P3.2	Hz	15.00	106	Activated by digital inputs
P3.7	Preset speed 3	P3.1	P3.2	Hz	20.00	126	Activated by digital inputs
P3.8	Preset speed 4	P3.1	P3.2	Hz	25.00	127	Activated by digital inputs
P3.9	Preset speed 5	P3.1	P3.2	Hz	30.00	128	Activated by digital inputs
P3.10	Preset speed 6	P3.1	P3.2	Hz	40.00	129	Activated by digital inputs
P3.11	Preset speed 7	P3.1	P3.2	Hz	50.00	130	Activated by digital inputs

Table 5.5: Frequency references

NOTE: These parameters display when P17.2 = 0.

5.6 Ramp and brake setup (Control panel: Menu PAR -> P4)

Code	Parameter	Min	Max	Unit	Default	ID	Note
P4.1	Ramp S-shape	0,0	10,0	s	0,0	500	0 = Linear >0 = S-curve ramp time
P4.2	Acceleration time 1	0,1	3000,0	s	3,0	103	Defines the time required for the output frequency to increase from zero frequency to maximum frequency
P4.3	Deceleration time 1	0,1	3000,0	s	3,0	104	Defines the time required for the output frequency to decrease from maximum frequency to zero frequency
P4.4	Ramp S-shape 2	0,0	10,0	s	0,0	501	See P4.1
P4.5	Acceleration time 2	0,1	3000,0	s	10,0	502	See P4.2
P4.6	Deceleration time 2	0,1	3000,0	s	10,0	503	See P4.3
P4.7	Flux Braking	0	3		0	520	0 = Off 1 = Deceleration 2 = Chopper 3 = Full Mode
P4.8	Flux Braking Current	0,5 x I_{Nunit}	2,0 x I_{Nunit}	A	I_{Nunit}	519	
P4.9	DC Braking Current	0,3 x I_{Nunit}	2,0 x I_{Nunit}	A	I_{Nunit}	507	Defines the current injected into the motor during DC braking
P4.10	Stop DC current time	0,00	600,00	s	0,00	508	Determines if braking is ON or OFF and the braking time of the DC brake when the motor is stopping 0 = Not active
P4.11	Stop DC current frequency	0,10	10,00	Hz	1,50	515	The output frequency at which DC braking is applied
P4.12	Start DC current time	0,00	600,00	s	0,00	516	0 = Not active

Table 5.6: Ramp and brake setup

5.7 Digital inputs (Control panel: Menu PAR -> P5)

Code	Parameter	Min	Max	Unit	Default	ID	Note
P5.1	I/O control signal 1	0	6		1	403	0 = Not used 1 = DI1 2 = DI2 3 = DI3 4 = DI4 5 = DI5 6 = DI6
P5.2	I/O control signal 2	0	6		2	404	See P5.1
P5.3	Reverse	0	6		0	412	See P5.1
P5.4	Ext. fault Close	0	6		6	405	See P5.1
P5.5	Ext. fault Open	0	6		0	406	See P5.1
P5.6	Fault reset	0	6		3	414	See P5.1
P5.7	Run enable	0	6		0	407	See P5.1
P5.8	Preset speed B0	0	6		4	419	See P5.1
P5.9	Preset speed B1	0	6		5	420	See P5.1
P5.10	Preset speed B2	0	6		0	421	See P5.1
P5.11	Ramp time 2 selection	0	6		0	408	See P5.1
P5.12	Disable PI	0	6		0	1020	See P5.1
P5.13	Force to I/O	0	6		0	409	See P5.1

Table 5.7: Digital inputs

5.8 Analog inputs (Control panel: Menu PAR -> P6)

Code	Parameter	Min	Max	Unit	Default	ID	Note
P6.1	AI1 Signal range	0	1		0	379	0 = 0 - 100% (0 - 10 V) 1 = 20% - 100% (2 - 10 V)
P6.2	AI1 Custom min	-100,00	100,00	%	0,00	380	0.00 = No min scaling
P6.3	AI1 Custom max	-100,00	300,00	%	100,00	381	100.00 = No max scaling
P6.4	AI1 filter time	0,0	10,0	s	0,1	378	0 = no filtering
P6.5	AI2 signal range	0	1		0	390	0 = 0 - 100% (0 - 20 mA) 1 = 20% - 100% (4 - 20 mA)
P6.6	AI2 Custom min	-100,00	100,00	%	0,00	391	0.00 = No min scaling
P6.7	AI2 Custom max	-100,00	300,00	%	100,00	392	100.00 = No max scaling
P6.8	AI2 filter time	0,0	10,0	s	0,1	389	0 = no filtering

Table 5.8: Analog inputs

5.9 Digital outputs (Control panel: Menu PAR -> P8)

Code	Parameter	Min	Max	Unit	Default	ID	Selections
P8.1	RO1 signal selection	0	11		2	313	0 = Not used 1 = Ready 2 = Run 3 = Fault 4 = Fault Inverted 5 = Warning 6 = Reversed 7 = At Speed 8 = Motor regulator active 9 = FB Control Word B13 10 = FB Control Word B14 11 = FB Control Word B15
P8.2	RO2 signal selection	0	11		3	314	See P8.1
P8.3	DO1 signal selection	0	11		1	312	See P8.1
P8.4	RO2 inversion	0	1		0	1588	0 = No inversion 1 = Inverted

Table 5.9: Digital outputs

5.10 Analog outputs (Control panel: Menu PAR -> P9)

Code	Parameter	Min	Max	Unit	Default	ID	Selections
P9.1	Analog output signal selection	0	4		1	307	0 = Not used 1 = Output freq ($0-f_{max}$) 2 = Output current ($0-I_{nMotor}$) 3 = Motor torque ($0-T_{nMotor}$) 4 = PI output (0 - 100%)
P9.2	Analog output minimum	0	1		0	310	0 = 0 mA 1 = 4 mA

Table 5.10: Analog outputs

5.11 Protections (Control panel: Menu PAR -> P13)

Code	Parameter	Min	Max	Unit	Default	ID	Note
P13.1	Analog Input low fault	0	2		1	700	0 = No action 1 = Alarm 2 = Fault: Coast
P13.2	Undervoltage fault	1	2		2	727	1 = No response (no fault generated but drive still stops modulation) 2 = Fault:Coast
P13.3	Earth fault	0	2		2	703	See P13.1
P13.4	Output Phase Fault	0	2		2	702	See P13.1
P13.5	Stall protection	0	2		0	709	See P13.1
P13.6	Under load protection	0	2		0	713	See P13.1
P13.7	Motor thermal protection	0	2		2	704	See P13.1
P13.8	Mtp: Ambient temperature	-20	100	°C	40	705	Environment temperature
P13.9	Mtp: Zero speed cooling	0,0	150,0	%	40,0	706	Cooling as % at 0 speed
P13.10	Mtp: Thermal time constant	1	200	min	45	707	Motor thermal time constant
P13.23	FWD/REV conflict supervision	0	2		1	1463	Same as P13.1

Table 5.11: Protections

NOTE: These parameters are shown when P17.2 = 0.

5.12 Fault autoreset parameters (Control panel: Menu PAR -> P14)

Code	Parameter	Min	Max	Unit	Default	ID	Note
P14.1	Automatic Reset	0	1		0	731	0 = Disabled 1 = Enable
P14.2	Wait time	0,10	10,00	s	0,50	717	Waiting time after fault
P14.3	Trial time	0,00	60,00	s	30,00	718	Maximum time for trials
P14.5	Restart Function	0	2		2	719	0 = Ramping 1 = Flying 2 = From Start Function

Table 5.12: Fault autoreset parameters

NOTE: These parameters are shown when P17.2 = 0.

5.13 PI control parameters (Control panel: Menu PAR -> P15)

Code	Parameter	Min	Max	Unit	Default	ID	Note
P15.1	Setpoint source selection	0	3		0	332	0 = Fixed setpoint % 1 = AI1 2 = AI2 3 = Fieldbus (ProcessDataIn1)
P15.2	Fixed setpoint	0,0	100,0	%	50,0	167	Fixed setpoint
P15.4	Feedback source selection	0	2		1	334	0 = AI1 1 = AI2 2 = Fieldbus (Process-DataIn2)
P15.5	Feedback value minimum	0,0	50,0	%	0,0	336	Value at minimum signal
P15.6	Feedback value maximum	10,0	300,0	%	100,0	337	Value at maximum signal
P15.7	P gain	0,0	1000,0	%	100,0	118	Proportional gain
P15.8	I time	0,00	320,00	s	10,00	119	Integrative time
P15.10	Error inversion	0	1		0	340	0 = Direct (Feedback < Setpoint -> Increase PID output) 1 = Inverted (Feedback > Setpoint -> Decrease PID output)

Table 5.13: PI control parameters

NOTE: These parameters are shown when **P17.2 = 0**.

5.14 Application Setting (Control panel: Menu PAR -> P17)

Code	Parameter	Min	Max	Unit	Default	ID	Note
P17.1	Application Type	0	3		0	540	0 = Basic 1 = Pump 2 = Fan drive 3 = High Torque NOTE: Visible only when the startup wizard is active.
P17.2	Parameter conceal	0	1		1	115	0 = All parameters visible 1 = Only quick setup parameter group visible

Table 5.14: Application Setting parameters

5.15 System parameters

Code	Parameter	Min	Max	Default	ID	Note
Software information (MENU SYS -> V1)						
V1.1	API SW ID				2314	
V1.2	API SW version				835	
V1.3	Power SW ID				2315	
V1.4	Power SW version				834	
V1.5	Application ID				837	
V1.6	Application revision				838	
V1.7	System load				839	
Fieldbus parameter (MENU SYS - V2)						
V2.1	Communication status				808	Status of Modbus communication. Format: xx.yyy where xx = 0 - 64 (number of error messages) yyy = 0 - 999 (number of good messages)
P2.2	Fieldbus protocol	0	1	0	809	0 = Not used 1 = Modbus used
P2.3	Slave address	1	255	1	810	Default setting: None parity, 1 stop bit
P2.4	Baud rate	0	5	5	811	0 = 300 1 = 600 2 = 1200 3 = 2400 4 = 4800 5 = 9600
P2.7	Communication timeout	0	255	10	814	1 = 1 sec 2 = 2 sec, etc.

Table 5.15: System parameters

Code	Parameter	Min	Max	Default	ID	Note
P2.8	Reset communication status	0	1	0	815	
Other information						
V3.1	MWh counter				827	Million watt hour
V3.2	Power on days				828	
V3.3	Power on hours				829	
V3.4	Run counter: Days				840	
V3.5	Run counter: Hours				841	
V3.6	Fault counter				842	
P4.2	Restore factory defaults	0	1	0	831	1 = Restores factory defaults for all parameters
F5.x	Active Fault menu					
F6.x	Fault History menu					

Table 5.15: System parameters

6. FAULT TRACING

Fault code	Fault name	Fault code	Fault name
1	Overcurrent	25	Microcontroller watchdog fault
2	Overvoltage	27	Back EMF protection
3	Earth fault	29	Thermistor fault
8	System fault	34	Internal bus communication
9	Undervoltage	35	Application fault
11	Output phase fault	41	IGBT Overtemperature
13	Frequency converter undertemperature	50	Analog input select 20% - 100% (selected signal range 4 to 20 mA or 2 to 10 V)
14	Frequency converter over-temperature	51	External fault
15	Motor stalled	53	Fieldbus fault
16	Motor overtemperature	55	Wrong run fault (FWD/REV conflict)
17	Motor underload	57	Identification fault
22	EEPROM checksum fault	111	Temperature fault

Table 6.1: Fault codes. See the User Manual for detailed fault descriptions.

7. GENERAL DATA

Dimensions and weight	Frame	Height (mm)	Width (mm)	Depth (mm)	Weight (kg)
	MI1	160	66	98	0.5
	MI2	195	90	102	0.7
	MI3	254	100	109	1
Supply network	Networks	Vacon 10 (400 V) cannot be used with corner grounded networks			
	Short circuit current	Maximum short circuit current has to be 50 kA			
Motor connection	Output voltage	0 - U_{in}			
	Output current	Continuous rated current I_N at ambient temperature max +50 °C (depends on the unit size), overload 1.5 x I_N max 1 min/10 min			
Control connection	Digital input	Positive; Logic 1: 8...+30V; Logic 0: 0...1.5V, $R_i = 20K\Omega$			
	Analog input voltage	0....+10V, $R_i = 300 K\Omega$ (min)			
	Analog input current	0(4)...20mA, $R_i = 200\Omega$			
	Analog output	0(4)...20mA, $R_L = 500\Omega$			
	Digital output	Open collector, max load 35V/50mA			
	Relay output	Switching load: 250Vac/3A, 24V DC 3A			
	Auxiliary voltage	$\pm 20\%$, max. load 50mA			
Ambient conditions	Ambient operating temperature	-10 °C (no frost)...+40/50 °C (depends on the unit size): rated loadability I_N When the MI1-3 is installed side-by-side, the ambient operating temperature is always 40 °C. This also applies to the IP21/Nema1 option in MI1-3.			
	Storage temperature	-40 °C...+70 °C			
	Relative humidity	0...95% RH, non-condensing, non-corrosive, no dripping water			
	Altitude	100% load capacity (no derating) up to 1000 m; 1% derating for each 100 m above 1000 m; max 2000 m			
	Enclosure class	IP20/IP21/Nema1 for MI1-3.			
	Pollution degree	PD2			
EMC	Immunity	Complies with EN50082-1, -2, EN61800-3			
	Emissions (see detailed descriptions in Vacon 10 User Manual at www.vacon.com)	230V: Complies with EMC category C2; with internal RFI filter. 400V: Complies with EMC category C2; with internal RFI filter. Both: No EMC emission protection (Vacon level N); without RFI filter.			
Standards	For EMC: EN61800-3 For safety: UL508C, EN61800-5				

Certificates and manufacturer's declarations of conformity		For safety: CE, UL, cUL, KC For EMC: CE, KC (see unit nameplate for more detailed approvals)
--	--	--

Cable and fuse requirements (see detailed data in Vacon 10 User Manual at www.vacon.com) 380 - 480 V, 3~ 208 - 240 V, 3~	Frame	Fuse [A]	Mains cable Cu (mm ²)	Terminal cable min-max (mm ²)		
				Main	Earth	Control and relay
	MI1	6	3*1.5+1.5	1.5-4	0.5-1.5	
	MI2	10				
	MI3	20				
115 V, 1~	MI2	20	2*2.5+2.5	1.5-4	0.5-1.5	
	MI3	32	2*6+6			
208 - 240, 1~	MI1	10	2*1.5+1.5	1.5-4	0.5-1.5	
	MI2	20	2*2.5+2.5			
	MI3	32	2*6+6			
600 V	MI3	6	3*1.5+1.5	1.5-4	0.5-1.5	
	MI3	10				
	MI3	20	3*2.5+2.5	1.5-6		

- The drive can be connected to the power supply with the above-mentioned fuses. The short circuit current of the power supply may not exceed 50 kA.
- Use cables with heat resistance of at least +70 °C.
- The fuses also function as cable overload protection.
- These instructions only apply to cases with one motor and one cable connection from the frequency converter to the motor.
- In order to comply with standard EN61800-5-1, the protective conductor should be **at least 10 mm² Cu or 16 mm² Al**. Another option is to use an additional protective conductor of at least the same size as the original one.

Vacon 10 power ratings

Mains voltage 208 - 240 V, 50/60 Hz, 1~ series							
Fre- quency converter type	Rated loadability		Motor shaft power		Nominal input cur- rent	Mechanical size	Weight (kg)
	100% contin- uous current I_N [A]	150% over- load current [A]	P [HP]	P [KW]	[A]		
0001	1.7	2.6	0.33	0.25	4.2	M11	0.55
0002	2.4	3.6	0.5	0.37	5.7	M11	0.55
0003	2.8	4.2	0.75	0.55	6.6	M11	0.55
0004	3.7	5.6	1	0.75	8.3	M12	0.7
0005	4.8	7.2	1.5	1.1	11.2	M12	0.7
0007	7	10.5	2	1.5	14.1	M12	0.7
0009*	9.6	14.4	3	2.2	22.1	M13	0.99

Table 7.1: Vacon 10 power ratings, 208 - 240 V

* The maximum ambient operating temperature of this drive is 40 °C!

Mains voltage 208 - 240 V, 50/60 Hz, 3~ series							
Fre- quency converter type	Rated loadability		Motor shaft power		Nominal input cur- rent	Mechanical size	Weight (kg)
	100% contin- uous current I_N [A]	150% over- load current [A]	P [HP]	P [KW]	[A]		
0001	1.7	2.6	0.33	0.25	2.7	M11	0.55
0002	2.4	3.6	0.5	0.37	3.5	M11	0.55
0003	2.8	4.2	0.75	0.55	3.8	M11	0.55
0004	3.7	5.6	1	0.75	4.3	M12	0.7
0005	4.8	7.2	1.5	1.1	6.8	M12	0.7
0007*	7	10.5	2	1.5	8.4	M12	0.7
0011*	11	16.5	3	2.2	13.4	M13	0.99

Table 7.2: Vacon 10 power ratings, 208 - 240 V, 3~

*The maximum ambient operating temperature of this drive is +40°C!

Mains voltage 115 V, 50/60 Hz, 1~ series							
Fre- quency converter type	Rated loadability		Motor shaft power		Nominal input cur- rent [A]	Mechanical size	Weight [Kg]
	100% contin- uous current I_N [A]	150% over- load current [A]	P [HP]	P [KW]			
0001	1.7	2.6	0.33	0.25	9.2	MI2	0.7
0002	2.4	3.6	0.5	0.37	11.6	MI2	0.7
0003	2.8	4.2	0.75	0.55	12.4	MI2	0.7
0004	3.7	5.6	1	0.75	15	MI2	0.7
0005	4.8	7.2	1.5	1.1	16.5	MI3	0.99

Table 7.3: Vacon 10 power ratings, 115 V, 1~

Mains voltage 380 - 480 V, 50/60 Hz, 3~ series							
Fre- quency converter type	Rated loadability		Motor shaft power		Nominal input cur- rent [A]	Mechanical size	Weight [kg]
	100% contin- uous current I_N [A]	150% over- load current [A]	P [HP]	P [KW]			
0001	1.3	2	0.5	0.37	2.2	MI1	0.55
0002	1.9	2.9	0.75	0.55	2.8	MI1	0.55
0003	2.4	3.6	1	0.75	3.2	MI1	0.55
0004	3.3	5	1.5	1.1	4	MI2	0.7
0005	4.3	6.5	2	1.5	5.6	MI2	0.7
0006	5.6	8.4	3	2.2	7.3	MI2	0.7
0008	7.6	11.4	4	3	9.6	MI3	0.99
0009	9	13.5	5	4	11.5	MI3	0.99
0012	12	18	7.5	5.5	14.9	MI3	0.99

Table 7.4: Vacon 10 power ratings, 380 - 480 V

Mains voltage 600 V, 50/60 Hz, 3~ series							
Fre- quency converter type	Rated loadability		Motor shaft power		Nominal input cur- rent [A]	Mechanical size	Weight (kg)
	100% continu- ous current I_N [A]	150% over- load current [A]	P [HP]	P [KW]			
0002	1.7	2.6	1	0.75	2	MI3	0.99
0003	2.7	4.2	2	1,5	3.6	MI3	0.99
0004	3,9	5,9	3	2,2	5	MI3	0.99
0006	6,1	9,2	5	3.7	7,6	MI3	0.99
0009	9	13,5	7.5	5,5	10,4	MI3	0.99

Table 7.5: Vacon 10 power ratings, 600 V

Note: The input currents are calculated values with 100 kVA line transformer supply.

Quick Modbus setup

1	A: Select Fieldbus as remote control place: P2.1 to 1 – Fieldbus B: Set Modbus RTU protocol to "ON:" S2.2 to 1 – Modbus
2	A. Set Control Word to "0" [2001] B. Set Control Word to "1" [2001] C. Frequency converter status is RUN D. Set Reference value to "5000" [50.00%] [2003] E. Actual Speed is 5000 [25.00 Hz if MinFreq is 0.00 Hz and MaxFreq is 50.00 Hz] F. Set Control Word to "0" [2001] G. Frequency converter status is STOP

VACON[®]

DRIVEN BY DRIVES

Find your nearest Vacon office
on the Internet at:

www.vacon.com

Manual authoring:
documentation@vacon.com

Vacon Plc.
Runsorintie 7
65380 Vaasa
Finland

Subject to change without prior notice
© 2012 Vacon Plc.

Document ID:



Rev. F1