

**VACON<sup>®</sup> 100**  
AC DRIVES

# APPLICATION MANUAL

**VACON<sup>®</sup>**



# PREFACE

Document ID:	DPD00927G
Date:	18.11.2015
Software version:	FW0072V020

## ABOUT THIS MANUAL

This manual is copyright of Vacon Plc. All Rights Reserved.

In this manual, you can read about the functions of the Vacon® AC drive and how to use the drive. The manual has the same structure than the menu of the drive (chapters 1 and 4-8).

### Chapter 1, Quick Startup Guide

- How to start the work with the control panel.

### Chapter 2, Wizards

- Making a selection of the application configuration.
- Setting up an application quickly.
- The different applications with examples.

### Chapter 3, User Interfaces

- The display types and how to use the control panel.
- The PC tool Vacon Live.
- The functions of the fieldbus.

### Chapter 4, Monitoring menu

- Data on the monitoring values.

### Chapter 5, Parameter menu

- A list of all the parameters of the drive.

### Chapter 6, Diagnostics menu

### Chapter 7, I/O and Hardware menu

### Chapter 8, User settings, favourites and user level menus

### Chapter 9, Parameter descriptions

- How to use the parameters.
- Digital and analogue input programming.
- Application-specific functions.

## Chapter 10, Fault tracing

- The faults and their causes.
- Resetting the faults.

## Chapter 11, Appendix

- Data on the different default values of the applications.

This manual includes a large quantity of parameter tables. These instructions tell you how to read the tables.

Index	Parameter	Min	Max	Unit	Default	ID	Description
							

- |                                                                                                                                                                                                                                                                                                           |                                                                                                                                                                                                                                                                                             |
|-----------------------------------------------------------------------------------------------------------------------------------------------------------------------------------------------------------------------------------------------------------------------------------------------------------|---------------------------------------------------------------------------------------------------------------------------------------------------------------------------------------------------------------------------------------------------------------------------------------------|
| <p>A. The location of the parameter in the menu, that is, the parameter number.</p> <p>B. The name of the parameter.</p> <p>C. The minimum value of the parameter.</p> <p>D. The maximum value of the parameter.</p> <p>E. The unit of the value of the parameter. The unit shows if it is available.</p> | <p>F. The value that was set in the factory.</p> <p>G. The ID number of the parameter.</p> <p>H. A short description of the values of the parameter and/or its function.</p> <p>I. When the symbol shows, you can find more data about the parameter in Chapter Parameter descriptions.</p> |
|-----------------------------------------------------------------------------------------------------------------------------------------------------------------------------------------------------------------------------------------------------------------------------------------------------------|---------------------------------------------------------------------------------------------------------------------------------------------------------------------------------------------------------------------------------------------------------------------------------------------|

**NOTE!** You can download the English and French product manuals with applicable safety, warning and caution information from [www.vacon.com/downloads](http://www.vacon.com/downloads).

**REMARQUE** Vous pouvez télécharger les versions anglaise et française des manuels produit contenant l'ensemble des informations de sécurité, avertissements et mises en garde applicables sur le site [www.vacon.com/downloads](http://www.vacon.com/downloads).

## FUNCTIONS OF THE VACON® AC DRIVE

- You can select one of the preset applications for your process: Standard, Local/Remote, Multi-step speed, PID control, Multi-purpose or Motor potentiometer. The drive automatically makes some of the necessary settings, which makes the commissioning easy.
- Wizards for the first startup and the Fire mode.
- Wizards for each application: Standard, Local/Remote, Multi-step speed, PID control, Multi-purpose or Motor potentiometer.
- The FUNCT button for an easy change between the local and the remote control place. The remote control place can be I/O or fieldbus. You can make a selection of the remote control place with a parameter.
- 8 preset frequencies.
- Motor potentiometer functions.
- A joystick control.
- A jogging function.
- 2 programmable ramp times, 2 supervisions and 3 ranges of prohibited frequencies.
- A forced stop.
- A control page to operate and monitor of the most important values quickly.
- A fieldbus data mapping.
- An automatic reset.
- Different pre-heat modes to prevent condensation problems.
- A maximum output frequency of 320 Hz.
- A Real time clock and timer functions (an optional battery is necessary). It is possible to program 3 time channels to get different functions on the drive.
- An external PID controller is available. You can use it, for example, to control a valve with the I/O of the AC drive.
- A sleep mode function that automatically enables and disables the operation of the drive to save energy.
- A 2-zone PID controller with 2 different feedback signals: minimum and maximum control.
- 2 setpoint sources for the PID control. You can make the selection with a digital input.
- A function for PID setpoint boost.
- A feedforward function to make the response to the process changes better.
- A process value supervision.
- A Multi-pump control.
- A maintenance counter.
- Pump control functions: priming pump control, jockey pump control, pump impeller auto-cleaning, pump input pressure supervision and frost protection function.



# TABLE OF CONTENTS

## Preface

About this manual .....	3
Functions of the Vacon® AC drive .....	5

<b>1 Quick Startup Guide .....</b>	<b>12</b>
1.1 Control panel and keypad .....	12
1.2 The displays .....	12
1.3 First start-up .....	13
1.4 Description of the applications .....	15
1.4.1 Standard application .....	15
1.4.2 Local/Remote application .....	21
1.4.3 Multi-step speed application .....	27
1.4.4 PID control application .....	33
1.4.5 Multi-purpose application .....	39
1.4.6 Motor potentiometer application .....	46
<b>2 Wizards .....</b>	<b>53</b>
2.1 Standard application wizard .....	53
2.2 Local/Remote application wizard .....	54
2.3 Multi-step speed application wizard .....	55
2.4 PID control application wizard .....	56
2.5 Multi-purpose application wizard .....	58
2.6 Motor potentiometer application wizard .....	59
2.7 Multi-pump wizard .....	60
2.8 Fire mode wizard .....	62
<b>3 User interfaces .....</b>	<b>64</b>
3.1 Navigation on the keypad .....	64
3.2 Using the graphical display .....	66
3.2.1 Editing the values .....	66
3.2.2 Resetting a fault .....	69
3.2.3 The FUNCT button .....	69
3.2.4 Copying the parameters .....	73
3.2.5 Comparing the parameters .....	75
3.2.6 Help texts .....	77
3.2.7 Using the Favourites menu .....	78
3.3 Using the text display .....	78
3.3.1 Editing the values .....	79
3.3.2 Resetting a fault .....	80
3.3.3 The FUNCT button .....	80
3.4 Menu structure .....	84
3.4.1 Quick setup .....	85
3.4.2 Monitor .....	85
3.5 Vacon Live .....	87

<b>4</b>	<b>Monitoring menu</b> .....	<b>88</b>
4.1	Monitor group .....	88
4.1.1	Multimonitor .....	88
4.1.2	Trend curve .....	89
4.1.3	Basic .....	92
4.1.4	I/O .....	94
4.1.5	Temperature inputs .....	94
4.1.6	Extras and advanced .....	95
4.1.7	Timer functions monitoring .....	96
4.1.8	PID controller monitoring .....	97
4.1.9	External PID controller monitoring .....	98
4.1.10	Multi-pump monitoring .....	98
4.1.11	Maintenance counters .....	98
4.1.12	Fieldbus process data monitoring .....	99
<b>5</b>	<b>Parameters menu</b> .....	<b>100</b>
5.1	Group 3.1: Motor settings .....	100
5.2	Group 3.2: Start/stop setup .....	105
5.3	Group 3.3: References .....	107
5.4	Group 3.4: Ramps and brakes setup .....	112
5.5	Group 3.5: I/O configuration .....	114
5.6	Group 3.6: Fieldbus data mapping .....	126
5.7	Group 3.7: Prohibit frequencies .....	127
5.8	Group 3.8: Supervisions .....	128
5.9	Group 3.9: Protections .....	129
5.10	Group 3.10: Automatic reset .....	135
5.11	Group 3.11: Application settings .....	136
5.12	Group 3.12: Timer functions .....	137
5.13	Group 3.13: PID controller .....	139
5.14	Group 3.14: External PID controller .....	151
5.15	Group 3.15: Multi-pump .....	155
5.16	Group 3.16: Maintenance counters .....	156
5.17	Group 3.17: Fire mode .....	157
5.18	Group 3.18: Motor preheat parameters .....	158
5.19	Group 3.19: Drive Customizer .....	158
5.20	Group 3.20: Mechanical brake .....	159
5.21	Group 3.21: Pump control .....	160
<b>6</b>	<b>Diagnostics menu</b> .....	<b>161</b>
6.1	Active faults .....	161
6.2	Reset faults .....	161
6.3	Fault history .....	161
6.4	Total counters .....	161
6.5	Trip counters .....	163
6.6	Software info .....	164
<b>7</b>	<b>I/O and hardware menu</b> .....	<b>165</b>
7.1	Basic I/O .....	165
7.2	Option board slots .....	167



7.3	Real time clock .....	168
7.4	Power unit settings .....	168
7.5	Keypad .....	170
7.6	Fieldbus .....	170
<b>8</b>	<b>User settings, favourites and user level menus .....</b>	<b>175</b>
8.1	User settings .....	175
8.1.1	Parameter backup .....	176
8.2	Favourites .....	176
8.2.1	Adding an item to the Favourites .....	177
8.2.2	Removing an item from the Favourites .....	177
8.3	User levels .....	178
8.3.1	Changing the access code of the user levels .....	179
<b>9</b>	<b>Monitoring value descriptions .....</b>	<b>181</b>
9.1	Multimonitor .....	181
9.2	Basic .....	182
9.3	I/O .....	183
9.4	Temperature inputs .....	184
9.5	Extras and advanced .....	185
9.6	Timer functions .....	186
9.7	PID controller .....	187
9.8	External PID controller .....	188
9.9	Multi-pump .....	188
9.10	Maintenance counters .....	188
9.11	Fieldbus data .....	189
<b>10</b>	<b>Parameter descriptions .....</b>	<b>191</b>
10.1	Trend curve .....	191
10.2	Motor settings .....	192
10.2.1	Motor nameplate parameters .....	192
10.2.2	Motor control parameters .....	193
10.2.3	Motor limits .....	198
10.2.4	Open loop parameters .....	199
10.2.5	I/f start function .....	202
10.2.6	Torque stabilator function .....	203
10.2.7	Sensorless control .....	204
10.3	Start/Stop setup .....	204
10.4	References .....	214
10.4.1	Frequency reference .....	214
10.4.2	Torque reference .....	215
10.4.3	Torque control open loop .....	218
10.4.4	Preset frequencies .....	218
10.4.5	Motor potentiometer parameters .....	222
10.4.6	Joystick parameters .....	223
10.4.7	Jogging parameters .....	225

10.5	Ramps and brakes setup .....	227
10.5.1	Ramp 1 .....	227
10.5.2	Ramp 2 .....	228
10.5.3	Start magnetising .....	229
10.5.4	DC brake .....	229
10.5.5	Flux braking .....	229
10.6	I/O configuration .....	230
10.6.1	Programming of digital and analogue inputs .....	230
10.6.2	Default functions of programmable inputs .....	241
10.6.3	Digital inputs .....	241
10.6.4	Analogue inputs .....	247
10.6.5	Digital outputs .....	252
10.6.6	Analogue outputs .....	256
10.7	Fieldbus data map .....	260
10.8	Prohibit frequencies .....	261
10.9	Supervisions .....	263
10.10	Protections .....	263
10.10.1	General .....	263
10.10.2	Motor thermal protections .....	265
10.10.3	Motor stall protection .....	269
10.10.4	Underload protection .....	271
10.10.5	Quick stop .....	273
10.10.6	Temperature input fault .....	274
10.10.7	AI low protection .....	276
10.10.8	User-defined fault 1 .....	277
10.10.9	User-defined fault 2 .....	277
10.11	Automatic reset .....	277
10.12	Application settings .....	279
10.13	Timer functions .....	280
10.14	PID controller .....	285
10.14.1	Basic settings .....	285
10.14.2	Setpoints .....	287
10.14.3	Feedback .....	288
10.14.4	Feedforward .....	288
10.14.5	Sleep function .....	290
10.14.6	Feedback supervision .....	291
10.14.7	Pressure loss compensation .....	293
10.14.8	Soft fill .....	294
10.14.9	Input pressure supervision .....	296
10.14.10	Frost protection .....	298
10.15	External PID controller .....	299
10.16	Multi-pump function .....	300
10.16.1	Overpressure supervision .....	307
10.17	Maintenance counters .....	308
10.18	Fire mode .....	309
10.19	Motor preheat function .....	312
10.20	Drive customizer .....	313

10.21	Mechanical brake .....	313
10.22	Pump control .....	317
10.22.1	Auto-cleaning .....	317
10.22.2	Jockey pump .....	318
10.22.3	Priming pump .....	320
<b>11</b>	<b>Fault tracing .....</b>	<b>321</b>
11.1	A fault comes into view .....	321
11.1.1	Resetting with the Reset button .....	321
11.1.2	Resetting with a parameter in the graphical display .....	321
11.1.3	Resetting with a parameter in the text display .....	322
11.2	Fault history .....	323
11.2.1	Examining the Fault history in the graphical display .....	323
11.2.2	Examining the Fault history in the text display .....	324
11.3	Fault codes .....	326
11.4	Total and trip counters .....	338
11.4.1	Operating time counter .....	339
11.4.2	Operating time trip counter .....	339
11.4.3	Run time counter .....	340
11.4.4	Power on time counter .....	340
11.4.5	Energy counter .....	341
11.4.6	Energy trip counter .....	342
<b>12</b>	<b>Appendix 1 .....</b>	<b>344</b>
12.1	The default values of parameters in the different applications .....	344

# 1 QUICK STARTUP GUIDE

## 1.1 CONTROL PANEL AND KEYPAD

The control panel is the interface between the AC drive and the user. With the control panel, you can control the speed of a motor and monitor the status of the AC drive. You can also set the parameters of the AC drive.

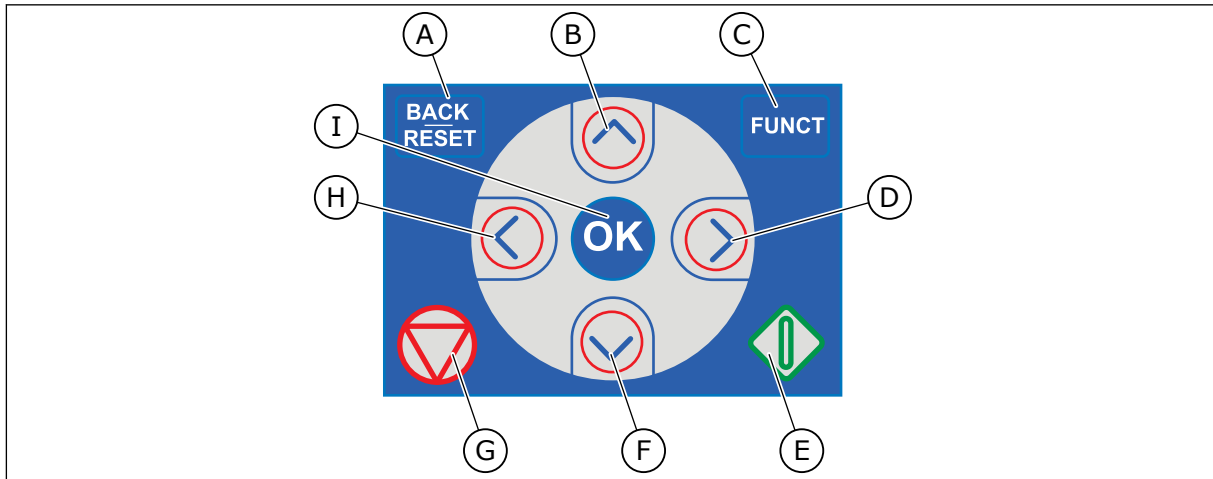

Fig. 1: The buttons of the keypad

- |                                                                                                                                                                                                                                                                                                                                                                          |                                                                                                                                                                                                                                                                                                                                                  |
|--------------------------------------------------------------------------------------------------------------------------------------------------------------------------------------------------------------------------------------------------------------------------------------------------------------------------------------------------------------------------|--------------------------------------------------------------------------------------------------------------------------------------------------------------------------------------------------------------------------------------------------------------------------------------------------------------------------------------------------|
| <p>A. The BACK/RESET button. Use it to move back in the menu, exit the Edit mode, reset a fault.</p> <p>B. The arrow button UP. Use it to scroll the menu up and to increase a value.</p> <p>C. The FUNCT button. Use it to change the rotation direction of the motor, access the control page, and change the control place. See more in <i>3 User interfaces</i>.</p> | <p>D. The arrow button RIGHT.</p> <p>E. The START button.</p> <p>F. The arrow button DOWN. Use it to scroll the menu down and to decrease a value.</p> <p>G. The STOP button.</p> <p>H. The arrow button LEFT. Use it to move the cursor left.</p> <p>I. The OK button. Use it to go into an active level or item, or to accept a selection.</p> |
|--------------------------------------------------------------------------------------------------------------------------------------------------------------------------------------------------------------------------------------------------------------------------------------------------------------------------------------------------------------------------|--------------------------------------------------------------------------------------------------------------------------------------------------------------------------------------------------------------------------------------------------------------------------------------------------------------------------------------------------|

## 1.2 THE DISPLAYS

There are 2 display types: the graphical display and the text display. The control panel always has the same keypad and buttons.

The display shows this data.

- The status of the motor and the drive.
- Faults in the motor and in the drive.
- Your location in the menu structure.

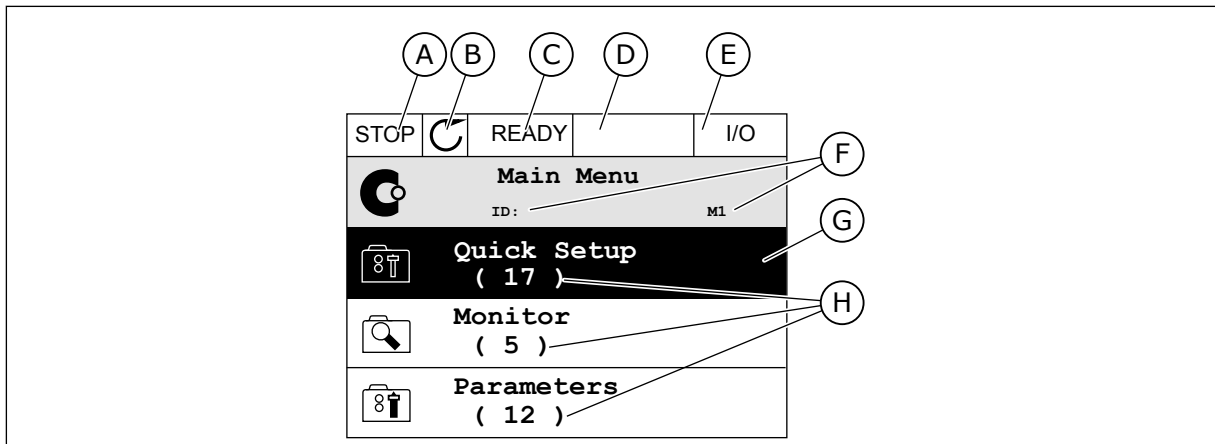

Fig. 2: The graphical display

- A. The first status field: STOP/RUN
- B. The rotation direction of the motor
- C. The second status field: READY/NOT READY/FAULT
- D. The alarm field: ALARM/-
- E. The control place field: PC/I/O/KEYPAD/ FIELDBUS
- F. The location field: the ID number of the parameter and the current location in the menu
- G. An activated group or item
- H. The number of items in the group in question

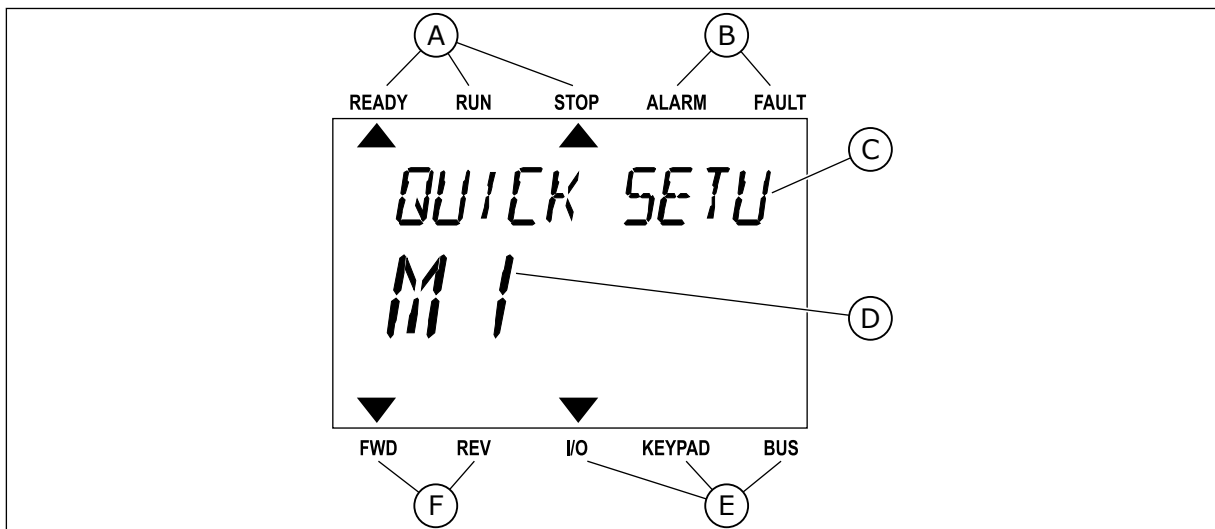

Fig. 3: The text display. If the text is too long to show, the text scrolls automatically on the display.

- A. The indicators of status
- B. The indicators of alarm and fault
- C. The name of the group or item of the current location
- D. The current location in the menu
- E. The indicators of the control place
- F. The indicators of the rotation direction

### 1.3 FIRST START-UP

The Start-up wizard tells you to give necessary data for the drive to control your procedure.

1	Language selection (P6.1)	The selection is different in all the language packages
2	Daylight saving* (P5.5.5)	Russia US EU OFF
3	Time* (P5.5.2)	hh:mm:ss
4	Year* (P5.5.4)	yyyy
5	Date* (P5.5.3)	dd.mm.

\* If a battery is installed, you see these steps.

6	Run Startup wizard?	Yes No
---	---------------------	-----------

To set the parameter values manually, make the selection *No* and push the OK button.

7	Make a selection of an application (P1.2 Application, ID212)	Standard Local/Remote Multi-step speed PID control Multi-purpose Motor potentiometer
8	Set a value for P3.1.2.2 Motor Type (so that it agrees with the nameplate)	PM motor Induction motor Reluctance motor
9	Set a value for P3.1.1.1 Motor Nominal Voltage (so that it agrees with the nameplate)	Range: Varies
10	Set a value for P3.1.1.2 Motor Nominal Frequency (so that it agrees with the nameplate)	Range: 8.00...320.00 Hz
11	Set a value for P3.1.1.3 Motor Nominal Speed (so that it agrees with the nameplate)	Range: 24...19200
12	Set a value for P3.1.1.4 Motor Nominal Current	Range: Varies
13	Set a value for P3.1.1.5 Motor Cos Phi	Range: 0.30-1.00

If you set Motor Type to *Induction Motor*, you see the next step. If your selection is *PM Motor*, the value of parameter P3.1.1.5 Motor Cos Phi is set to 1.00 and the wizard goes directly to step 14.

<b>14</b>	Set a value for P3.3.1.1 Minimum Frequency Reference	Range: 0.00...P3.3.1.2 Hz
<b>15</b>	Set a value for P3.3.1.2 Maximum Frequency Reference	Range: P3.3.1.1...320.00 Hz
<b>16</b>	Set a value for P3.4.1.2 Acceleration Time 1	Range: 0.1...300.0 s
<b>17</b>	Set a value for P3.4.1.3 Deceleration Time 1	Range: 0.1...300.0 s
<b>18</b>	Run the Application wizard?	Yes No

To continue to the application wizard, set the selection to *Yes* and push the OK button. See the description of the different application wizards in Chapter 2 *Wizards*.

After these selections, the Start-up wizard is completed. To start the Start-up wizard again, you have 2 alternatives. Go to the parameter P6.5.1 Restore Factory Defaults or to the parameter B1.1.2 Start-up Wizard. Then set the value to *Activate*.

## 1.4 DESCRIPTION OF THE APPLICATIONS

Use the parameter P1.2 (Application) to make a selection of an application for the drive. Immediately when the parameter P1.2 changes, a group of parameters get their preset values.

### 1.4.1 STANDARD APPLICATION

You can use the Standard application in speed-controlled processes where no special functions are necessary, for example pumps, fans, or conveyors.

It is possible to control the drive from the keypad, Fieldbus or I/O terminal.

When you control the drive with the I/O terminal, the frequency reference signal is connected to AI1 (0...10V) or AI2 (4...20mA). The connection depends the type of the signal. There are also 3 preset frequency references available. You can activate the preset frequency references with DI4 and DI5. The start/stop signals of the drive are connected to DI1 (start forward) and DI2 (start reverse).

It is possible to configure all the drive outputs freely in all the applications. There are 1 analogue output (Output Frequency) and 3 relay outputs (Run, Fault, Ready) available on the basic I/O board.

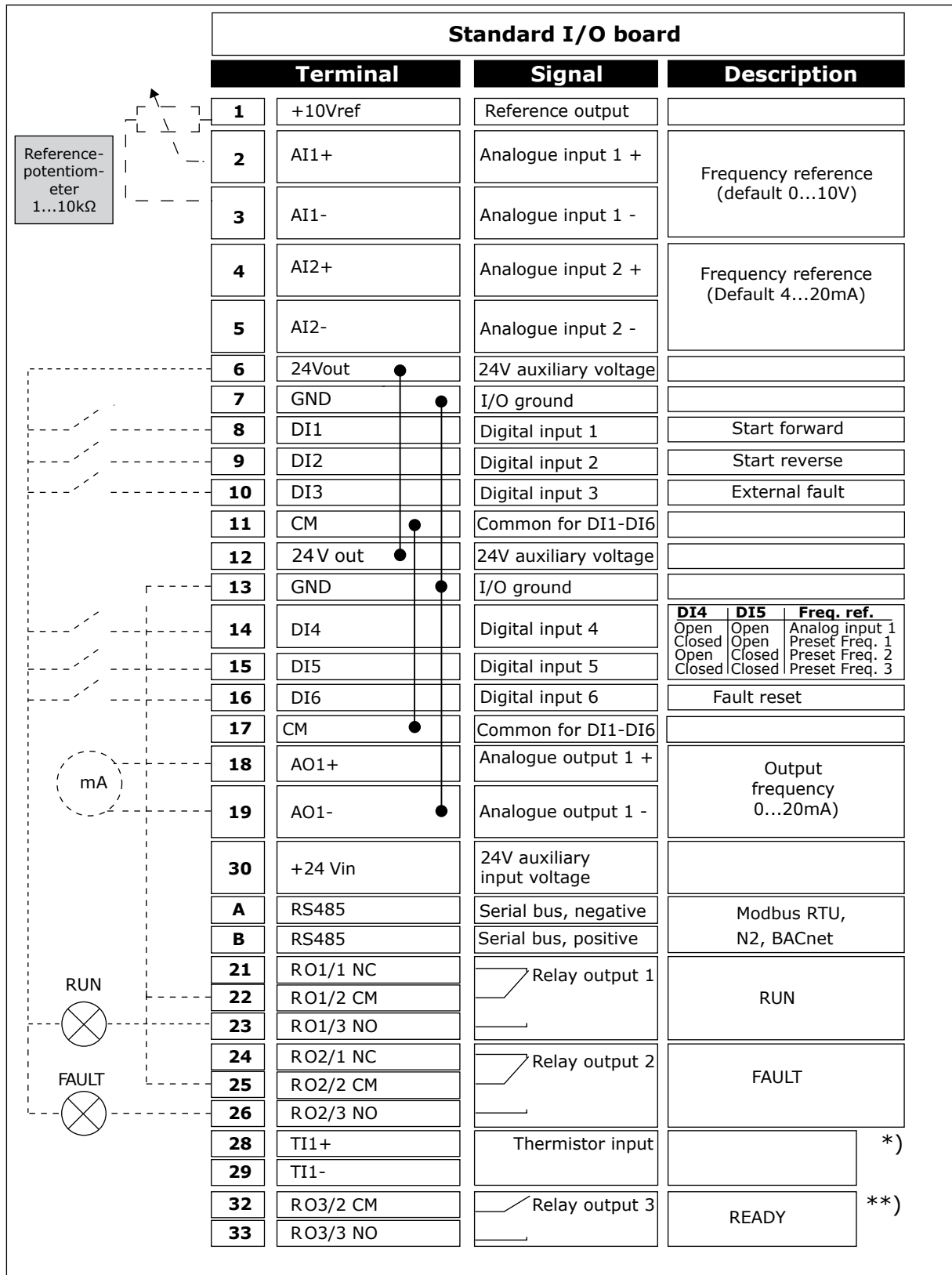

Fig. 4: The default control connections of the Standard application

\* = Available only in Vacon 100 X.



\*\* = For the DIP switch configurations in Vacon 100 X, see the Vacon 100 X Installation manual.

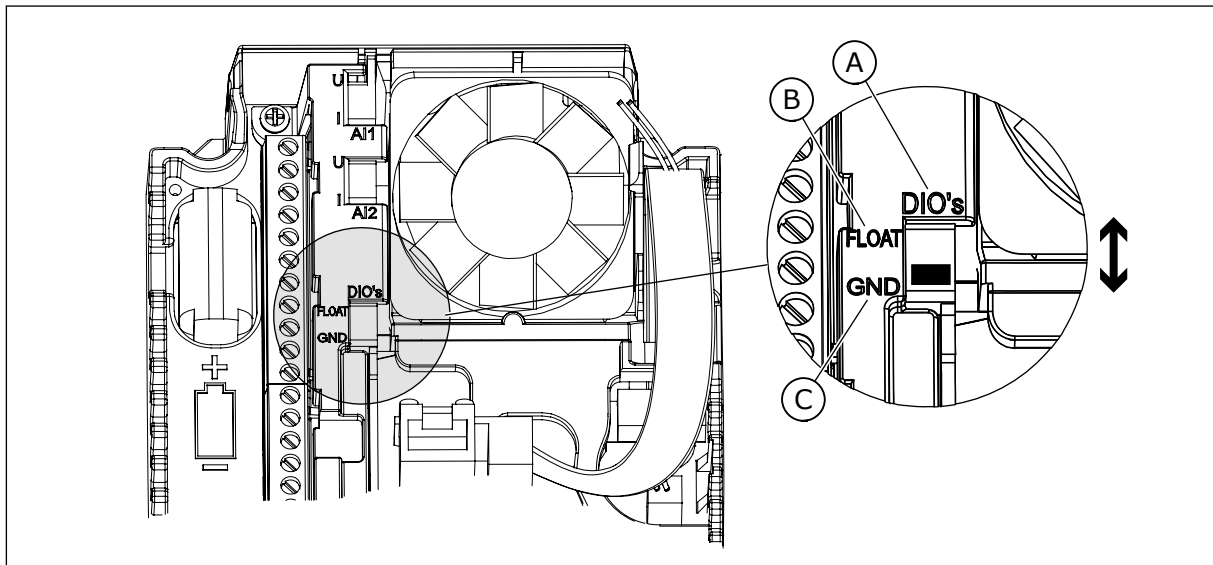

Fig. 5: The DIP switch

- A. Digital input DIP switch
- B. Floating

- C. Connected to GND (**Default**)

Table 2: M1.1 Wizards

Index	Parameter	Min	Max	Unit	Default	ID	Description
1.1.1	Startup wizard	0	1		0	1170	0 = Do not activate 1 = Activate  The selection Activate starts the Start-up wizard (see Chapter Table 1 The Start-up wizard).
1.1.3	Multi-pump Wizard	0	1		0	1671	The selection Activate starts the Multi-pump wizard (see Chapter 2.7 Multi-pump wizard).
1.1.4	Fire mode Wizard	0	1		0	1672	The selection Activate starts the Fire mode wizard (see Chapter 2.8 Fire mode wizard).

**Table 3: M1 Quick Setup**

Index	Parameter	Min	Max	Unit	Default	ID	Description
1.2	Application	0	5		0	212	0 = Standard 1 = Local/Remote 2 = Multi-Step Speed 3 = PID Control 4 = Multi-Purpose 5 = Motor Potentiometer
1.3	Minimum Frequency Reference	0.00	P1.4	Hz	0.0	101	
1.4	Maximum Frequency Reference	P1.3	320.0	Hz	50.0 / 60.0	102	
1.5	Acceleration Time 1	0.1	300.0	s	5.0	103	
1.6	Deceleration Time 1	0.1	300.0	s	5.0	104	
1.7	Motor Current Limit	I <sub>H</sub> *0.1	I <sub>S</sub>	A	Varies	107	
1.8	Motor Type	0	2		0	650	0 = Induction Motor 1 = Permanent Magnet Motor 2 = Reluctance Motor
1.9	Motor Nominal Voltage	Varies	Varies	V	Varies	110	Find this value U <sub>n</sub> on the nameplate of the motor. <b>NOTE!</b> Find out if the motor connection is Delta or Star.
1.10	Motor Nominal Frequency	8.0	320.0	Hz	50 / 60	111	Find this value f <sub>n</sub> on the nameplate of the motor.
1.11	Motor Nominal Speed	24	19200	Rpm	Varies	112	Find this value n <sub>n</sub> on the nameplate of the motor.
1.12	Motor Nominal Current	I <sub>H</sub> * 0.1	I <sub>H</sub> * 2	A	Varies	113	Find this value I <sub>n</sub> on the nameplate of the motor.
1.13	Motor Cos Phi (Power Factor)	0.30	1.00		Varies	120	Find this value on the nameplate of the motor.

**Table 3: M1 Quick Setup**

Index	Parameter	Min	Max	Unit	Default	ID	Description
1.14	Energy Optimization	0	1		0	666	0 = Disabled 1 = Enabled
1.15	Identification	0	2		0	631	0 = No action 1 = At standstill 2 = With rotation
1.16	Start Function	0	1		0	505	0 = Ramping 1 = Flying Start
1.17	Stop Function	0	1		0	506	0 = Coasting 1 = Ramping
1.18	Automatic Reset	0	1		0	731	0 = Disabled 1 = Enabled
1.19	Response to External Fault	0	3		2	701	0 = No action 1 = Alarm 2 = Fault (Stop according to stop mode) 3 = Fault (Stop by coasting)
1.20	Response to AI Low Fault	0	5		0	700	0 = No action 1 = Alarm 2 = Alarm+preset fault frequency (P3.9.1.13) 3 = Alarm + previous frequency 4 = Fault (Stop according to stop mode) 5 = Fault (Stop by coasting)
1.21	Remote Control Place	0	1		0	172	0 = I/O control 1 = Fieldbus control

**Table 3: M1 Quick Setup**

Index	Parameter	Min	Max	Unit	Default	ID	Description
1.22	I/O Control Reference A Selection	0	9		5	117	0 = Preset Frequency 1 = Keypad Reference 2 = Fieldbus 3 = AI1 4 = AI2 5 = AI1+AI2 6 = PID Reference 7 = Motor Potentiometer 8 = Joystick Reference 9 = Jogging Reference 10 = Block Out.1 11 = Block Out.2 12 = Block Out.3 13 = Block Out.4 14 = Block Out.5 15 = Block Out.6 16 = Block Out.7 17 = Block Out.8 18 = Block Out.9 19 = Block Out.10
1.23	Keypad Control Reference Selection	0	9		1	121	See P1.22.
1.24	Fieldbus Control Reference Selection	0	9		2	122	See P1.22.
1.25	AI1 Signal Range	0	1		0	379	0= 0..10V / 0..20mA 1= 2..10V / 4..20mA
1.26	AI2 Signal Range	0	1		1	390	0= 0..10V / 0..20mA 1= 2..10V / 4..20mA
1.27	R01 Function	0	51		2	1101	See P3.5.3.2.1
1.28	R02 Function	0	51		3	1104	See P3.5.3.2.1
1.29	R03 Function	0	51		1	1107	See P3.5.3.2.1
1.30	A01 Function	0	31		2	10050	See P3.5.4.1.1

**Table 4: M1.31 Standard**

Index	Parameter	Min	Max	Unit	Default	ID	Description
1.31.1	Preset Frequency 1	P1.3	P1.4	Hz	10.0	105	
1.31.2	Preset Frequency 2	P1.3	P1.4	Hz	15.0	106	
1.31.3	Preset Frequency 3	P1.3	P1.4	Hz	20.0	126	

#### 1.4.2 LOCAL/REMOTE APPLICATION

Use the Local/Remote application when, for example, it is necessary to switch between 2 different control places.

To change between the Local and the Remote control place, use DI6. When Remote control is active, you can give the start/stop commands from Fieldbus or from I/O terminal (DI1 and DI2). When Local control is active, you can give the start/stop commands from the keypad, Fieldbus or I/O terminal (DI4 and DI5).

For each control place, you can make a selection of the frequency reference from the keypad, Fieldbus or I/O terminal (AI1 or AI2).

It is possible to configure all the drive outputs freely in all the applications. There are 1 analogue output (Output Frequency) and 3 relay outputs (Run, Fault, Ready) available on the basic I/O board.

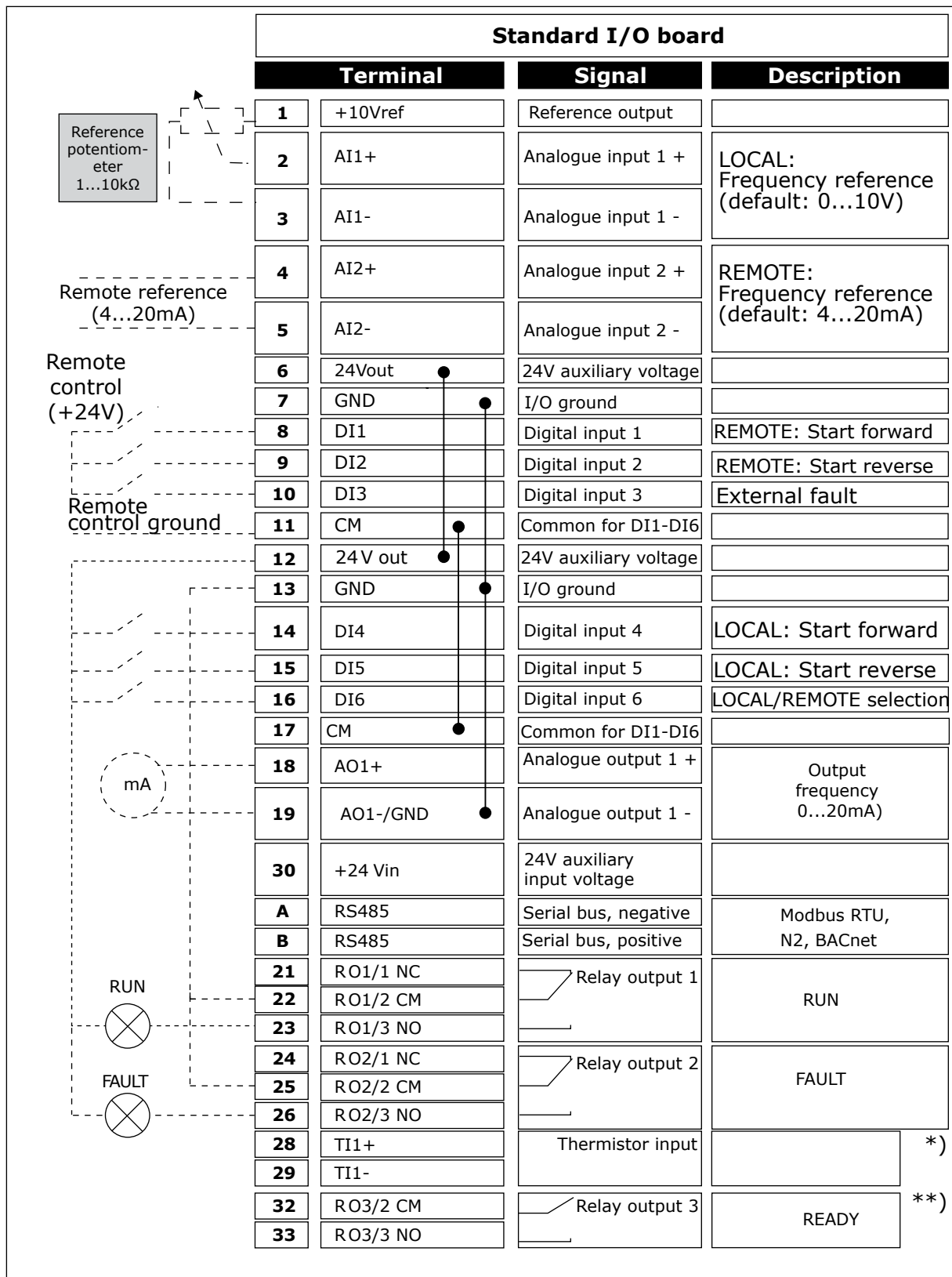

Fig. 6: The default control connections of the Local/Remote application

\* = Available only in Vacon 100 X.

\*\* = For the DIP switch configurations in Vacon 100 X, see the Vacon 100 X Installation manual.

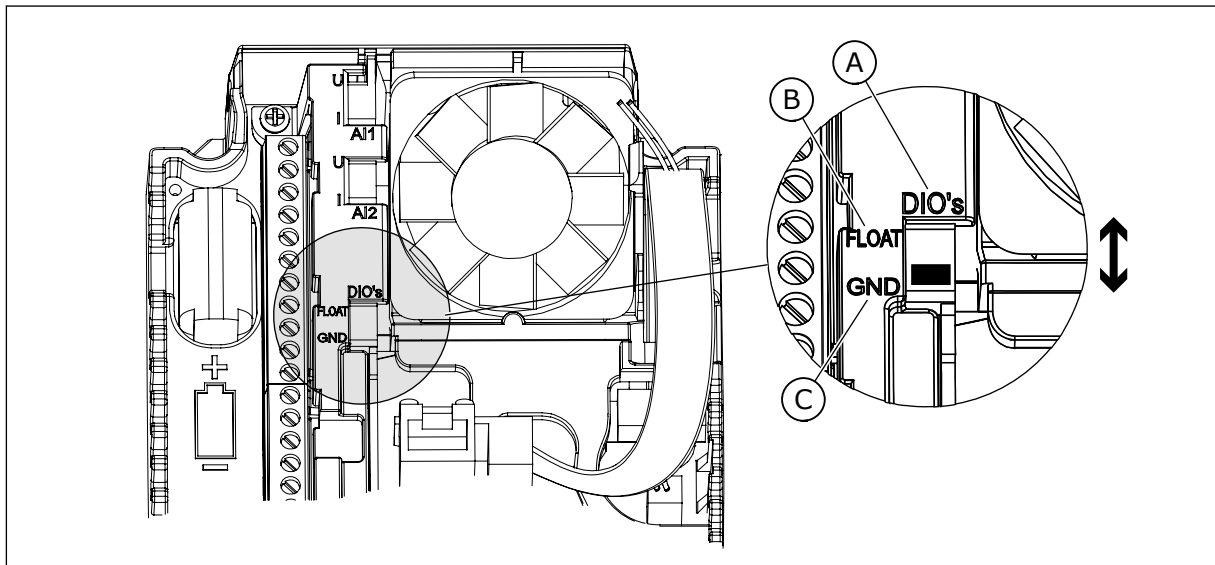

Fig. 7: The DIP switch

- A. Digital input DIP switch
- B. Floating

- C. Connected to GND (**Default**)

Table 5: M1.1 Wizards

Index	Parameter	Min	Max	Unit	Default	ID	Description
1.1.1	Startup wizard	0	1		0	1170	0 = Do not activate 1 = Activate  The selection Activate starts the Start-up wizard (see Chapter Table 1 The Start-up wizard).
1.1.3	Multi-pump Wizard	0	1		0	1671	The selection Activate starts the Multi-pump wizard (see Chapter 2.7 Multi-pump wizard).
1.1.4	Fire mode Wizard	0	1		0	1672	The selection Activate starts the Fire mode wizard (see Chapter 2.8 Fire mode wizard).

**Table 6: M1 Quick Setup**

Index	Parameter	Min	Max	Unit	Default	ID	Description
1.2	Application	0	5		1	212	0 = Standard 1 = Local/Remote 2 = Multi-Step Speed 3 = PID Control 4 = Multi-Purpose 5 = Motor Potentiometer
1.3	Minimum Frequency Reference	0.00	P1.4	Hz	0.0	101	
1.4	Maximum Frequency Reference	P1.3	320.0	Hz	50.0 / 60.0	102	
1.5	Acceleration Time 1	0.1	300.0	s	5.0	103	
1.6	Deceleration Time 1	0.1	300.0	s	5.0	104	
1.7	Motor Current Limit	I <sub>H</sub> *0.1	I <sub>S</sub>	A	Varies	107	
1.8	Motor Type	0	2		0	650	0 = Induction Motor 1 = Permanent Magnet Motor 2 = Reluctance Motor
1.9	Motor Nominal Voltage	Varies	Varies	V	Varies	110	Find this value U <sub>n</sub> on the nameplate of the motor. <b>NOTE!</b> Find out if the motor connection is Delta or Star.
1.10	Motor Nominal Frequency	8.0	320.0	Hz	50 / 60	111	Find this value f <sub>n</sub> on the nameplate of the motor.
1.11	Motor Nominal Speed	24	19200	Rpm	Varies	112	Find this value n <sub>n</sub> on the nameplate of the motor.
1.12	Motor Nominal Current	I <sub>H</sub> * 0.1	I <sub>H</sub> * 2	A	Varies	113	Find this value I <sub>n</sub> on the nameplate of the motor.
1.13	Motor Cos Phi (Power Factor)	0.30	1.00		Varies	120	Find this value on the nameplate of the motor.



**Table 6: M1 Quick Setup**

Index	Parameter	Min	Max	Unit	Default	ID	Description
1.14	Energy Optimization	0	1		0	666	0 = Disabled 1 = Enabled
1.15	Identification	0	2		0	631	0 = No action 1 = At standstill 2 = With rotation
1.16	Start Function	0	1		0	505	0 = Ramping 1 = Flying Start
1.17	Stop Function	0	1		0	506	0 = Coasting 1 = Ramping
1.18	Automatic Reset	0	1		0	731	0 = Disabled 1 = Enabled
1.19	Response to External Fault	0	3		2	701	0 = No action 1 = Alarm 2 = Fault (Stop according to stop mode) 3 = Fault (Stop by coasting)
1.20	Response to AI Low Fault	0	5		0	700	0 = No action 1 = Alarm 2 = Alarm+preset fault frequency (P3.9.1.13) 3 = Alarm + previous frequency 4 = Fault (Stop according to stop mode) 5 = Fault (Stop by coasting)
1.21	Remote Control Place	0	1		0	172	0 = I/O control 1 = Fieldbus control

**Table 6: M1 Quick Setup**

Index	Parameter	Min	Max	Unit	Default	ID	Description
1.22	I/O Control Reference A Selection	0	9		3	117	0 = Preset Frequency 0 1 = Keypad Reference 2 = Fieldbus 3 = AI1 4 = AI2 5 = AI1+AI2 6 = PID Reference 7 = Motor Potentiometer 8 = Joystick Reference 9 = Jogging Reference 10 = Block Out.1 11 = Block Out.2 12 = Block Out.3 13 = Block Out.4 14 = Block Out.5 15 = Block Out.6 16 = Block Out.7 17 = Block Out.8 18 = Block Out.9 19 = Block Out.10
1.23	Keypad Control Reference Selection	0	9		1	121	See P1.22.
1.24	Fieldbus Control Reference Selection	0	9		2	122	See P1.22.
1.25	AI1 Signal Range	0	1		0	379	0= 0..10V / 0..20mA 1= 2..10V / 4..20mA
1.26	AI2 Signal Range	0	1		1	390	0= 0..10V / 0..20mA 1= 2..10V / 4..20mA
1.27	R01 Function	0	51		2	1101	See P3.5.3.2.1
1.28	R02 Function	0	51		3	1104	See P3.5.3.2.1
1.29	R03 Function	0	51		1	1107	See P3.5.3.2.1
1.30	A01 Function	0	31		2	10050	See P3.5.4.1.1

**Table 7: M1.32 Local/Remote**

Index	Parameter	Min	Max	Unit	Default	ID	Description
1.32.1	I/O Control Reference B Selection	1	20		4	131	See P1.22
1.32.2	I/O B Control Force				DigIN SlotA.6	425	CLOSED = Force control place to I/O B
1.32.3	I/O B Reference Force				DigIN SlotA.6	343	CLOSED = Used frequency reference is specified by I/O Reference B parameter (P1.32.1)
1.32.4	Control Signal 1 B				DigIN SlotA.4	423	
1.32.5	Control Signal 2 B				DigIN SlotA.5	424	
1.32.6	Keypad Control Force				DigIN SlotA.1	410	
1.32.7	Fieldbus Control Force				DigIN Slot0.1	411	
1.32.8	External Fault (Close)				DigIN SlotA.3	405	OPEN = OK CLOSED = External fault
1.32.9	Fault Reset (Close)				DigIN Slot0.1	414	Resets all active faults when CLOSED

### 1.4.3 MULTI-STEP SPEED APPLICATION

You can use the Multi-step speed application with processes where more than 1 fixed frequency reference is necessary (for example test benches).

It is possible to use 1 + 7 frequency references: 1 basic reference (AI1 or AI2) and 7 preset references.

Make a selection of the preset frequency references with digital signals DI4, DI5 and DI6. If none of these inputs are active, the frequency reference is removed from the analogue input (AI1 or AI2). Give the start/stop commands from the I/O terminal (DI1 and DI2).

It is possible to configure all the drive outputs freely in all the applications. There are 1 analogue output (Output Frequency) and 3 relay outputs (Run, Fault, Ready) available on the basic I/O board.

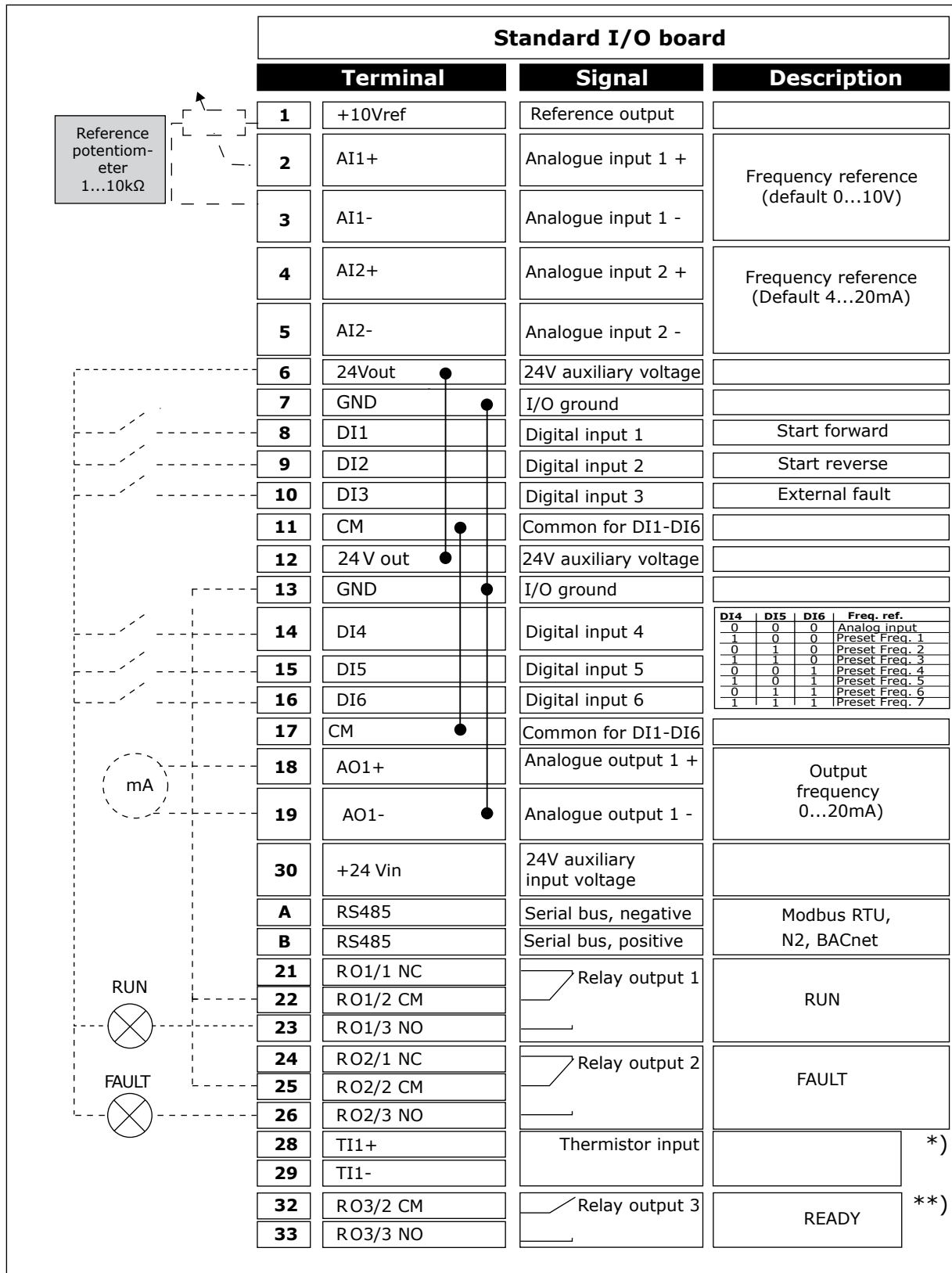

Fig. 8: The default control connections of the Multi-step speed application

\* = Available only in Vacon 100 X.

\*\* = For the DIP switch configurations in Vacon 100 X, see the Vacon 100 X Installation manual.

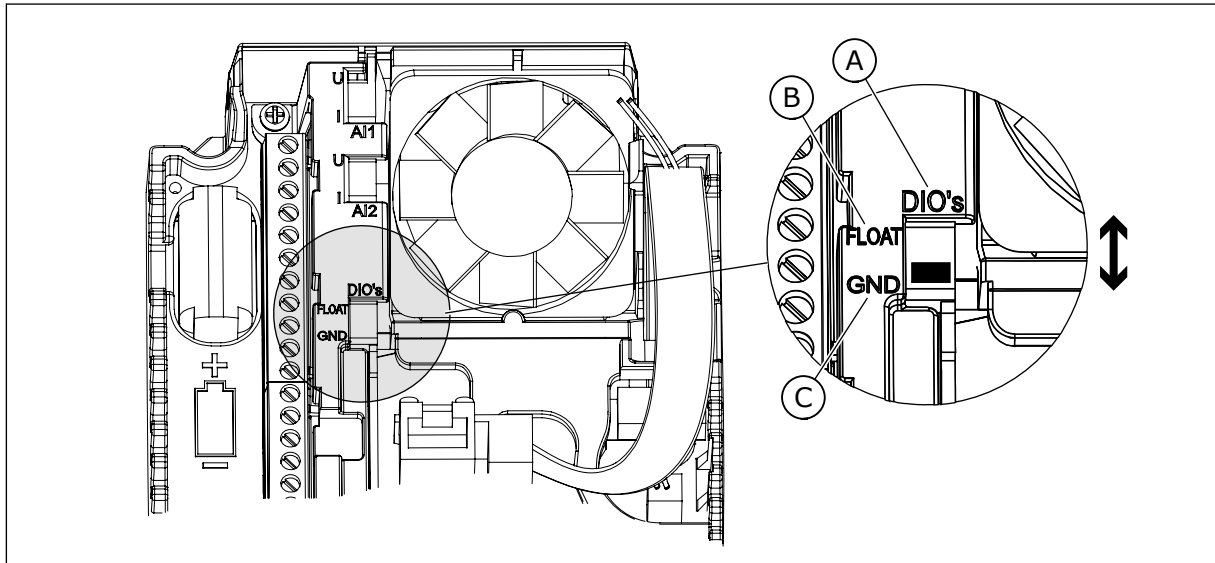

Fig. 9: The DIP switch

- A. Digital input DIP switch
- B. Floating

- C. Connected to GND (**Default**)

Table 8: M1.1 Wizards

Index	Parameter	Min	Max	Unit	Default	ID	Description
1.1.1	Startup wizard	0	1		0	1170	0 = Do not activate 1 = Activate  The selection Activate starts the Start-up wizard (see Chapter Table 1 The Start-up wizard).
1.1.3	Multi-pump Wizard	0	1		0	1671	The selection Activate starts the Multi-pump wizard (see Chapter 2.7 Multi-pump wizard).
1.1.4	Fire mode Wizard	0	1		0	1672	The selection Activate starts the Fire mode wizard (see Chapter 2.8 Fire mode wizard).

**Table 9: M1 Quick Setup**

Index	Parameter	Min	Max	Unit	Default	ID	Description
1.2	Application	0	5		2	212	0 = Standard 1 = Local/Remote 2 = Multi-Step Speed 3 = PID Control 4 = Multi-Purpose 5 = Motor Potentiometer
1.3	Minimum Frequency Reference	0.00	P1.4	Hz	0.0	101	
1.4	Maximum Frequency Reference	P1.3	320.0	Hz	50.0 / 60.0	102	
1.5	Acceleration Time 1	0.1	300.0	s	5.0	103	
1.6	Deceleration Time 1	0.1	300.0	s	5.0	104	
1.7	Motor Current Limit	I <sub>H</sub> *0.1	I <sub>S</sub>	A	Varies	107	
1.8	Motor Type	0	2		0	650	0 = Induction Motor 1 = Permanent Magnet Motor 2 = Reluctance Motor
1.9	Motor Nominal Voltage	Varies	Varies	V	Varies	110	Find this value U <sub>n</sub> on the nameplate of the motor. <b>NOTE!</b> Find out if the motor connection is Delta or Star.
1.10	Motor Nominal Frequency	8.0	320.0	Hz	50 / 60	111	Find this value f <sub>n</sub> on the nameplate of the motor.
1.11	Motor Nominal Speed	24	19200	Rpm	Varies	112	Find this value n <sub>n</sub> on the nameplate of the motor.
1.12	Motor Nominal Current	I <sub>H</sub> * 0.1	I <sub>H</sub> * 2	A	Varies	113	Find this value I <sub>n</sub> on the nameplate of the motor.
1.13	Motor Cos Phi (Power Factor)	0.30	1.00		Varies	120	Find this value on the nameplate of the motor.

**Table 9: M1 Quick Setup**

Index	Parameter	Min	Max	Unit	Default	ID	Description
1.14	Energy Optimization	0	1		0	666	0 = Disabled 1 = Enabled
1.15	Identification	0	2		0	631	0 = No action 1 = At standstill 2 = With rotation
1.16	Start Function	0	1		0	505	0 = Ramping 1 = Flying Start
1.17	Stop Function	0	1		0	506	0 = Coasting 1 = Ramping
1.18	Automatic Reset	0	1		0	731	0 = Disabled 1 = Enabled
1.19	Response to External Fault	0	3		2	701	0 = No action 1 = Alarm 2 = Fault (Stop according to stop mode) 3 = Fault (Stop by coasting)
1.20	Response to AI Low Fault	0	5		0	700	0 = No action 1 = Alarm 2 = Alarm+preset fault frequency (P3.9.1.13) 3 = Alarm + previous frequency 4 = Fault (Stop according to stop mode) 5 = Fault (Stop by coasting)
1.21	Remote Control Place	0	1		0	172	0 = I/O control 1 = Fieldbus control

**Table 9: M1 Quick Setup**

Index	Parameter	Min	Max	Unit	Default	ID	Description
1.22	I/O Control Reference A Selection	0	9		5	117	0 = Preset Frequency 1 = Keypad Reference 2 = Fieldbus 3 = AI1 4 = AI2 5 = AI1+AI2 6 = PID Reference 7 = Motor Potentiometer 8 = Joystick Reference 9 = Jogging Reference 10 = Block Out.1 11 = Block Out.2 12 = Block Out.3 13 = Block Out.4 14 = Block Out.5 15 = Block Out.6 16 = Block Out.7 17 = Block Out.8 18 = Block Out.9 19 = Block Out.10
1.23	Keypad Control Reference Selection	0	9		1	121	See P1.22.
1.24	Fieldbus Control Reference Selection	0	9		2	122	See P1.22.
1.25	AI1 Signal Range	0	1		0	379	0= 0..10V / 0..20mA 1= 2..10V / 4..20mA
1.26	AI2 Signal Range	0	1		1	390	0= 0..10V / 0..20mA 1= 2..10V / 4..20mA
1.27	R01 Function	0	51		2	1101	See P3.5.3.2.1
1.28	R02 Function	0	51		3	1104	See P3.5.3.2.1
1.29	R03 Function	0	51		1	1107	See P3.5.3.2.1
1.30	A01 Function	0	31		2	10050	See P3.5.4.1.1



**Table 10: M1.33 Multi-step speed**

Index	Parameter	Min	Max	Unit	Default	ID	Description
1.33.1	Preset Frequency 1	P1.3	P1.4	Hz	10.0	105	
1.33.2	Preset Frequency 2	P1.3	P1.4	Hz	15.0	106	
1.33.3	Preset Frequency 3	P1.3	P1.4	Hz	20.0	126	
1.33.4	Preset Frequency 4	P1.3	P1.4	Hz	25.0	127	
1.33.5	Preset Frequency 5	P1.3	P1.4	Hz	30.0	128	
1.33.6	Preset Frequency 6	P1.3	P1.4	Hz	40.0	129	
1.33.7	Preset Frequency 7	P1.3	P1.4	Hz	50.0	130	
1.33.8	Preset Frequency Mode	0	1		0	128	0 = Binary Coded 1 = Number of inputs. Preset frequency is selected according to how many of preset speed digital inputs are active.
1.33.9	External Fault (Close)				DigIN SlotA.3	405	CLOSED = OK OPEN = External fault
1.33.10	Fault Reset (Close)				DigIN Slot0.1	414	Resets all active faults when CLOSED

#### 1.4.4 PID CONTROL APPLICATION

You can use the PID control application with processes where you control the process variable (for example pressure) through control of the speed of the motor.

In this application, the internal PID controller of the drive is configured for 1 setpoint and 1 feedback signal.

It is possible to use 2 control places. Make the selection of the control place A or B with DI6. When control place A is active, the start/stop commands are given by DI1, and the PID controller gives the frequency reference. When control place B is active, start/stop commands are given by DI4, and AI1 gives the frequency reference.

It is possible to configure all the drive outputs freely in all the applications. There are 1 analogue output (Output Frequency) and 3 relay outputs (Run, Fault, Ready) available on the basic I/O board.

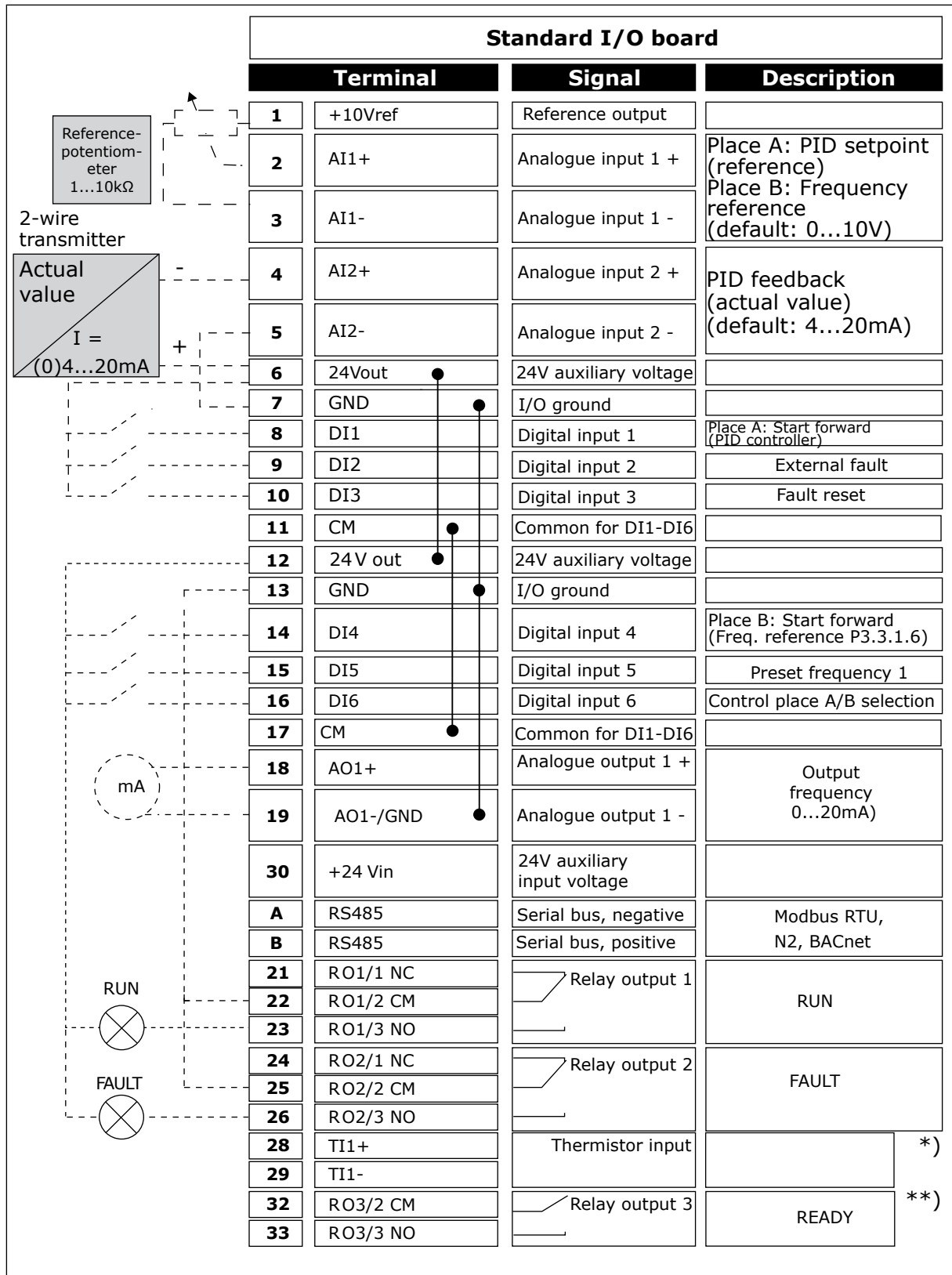

Fig. 10: The default control connections of the PID control application

\* = Available only in Vacon 100 X.

\*\* = For the DIP switch configurations in Vacon 100 X, see the Vacon 100 X Installation manual.

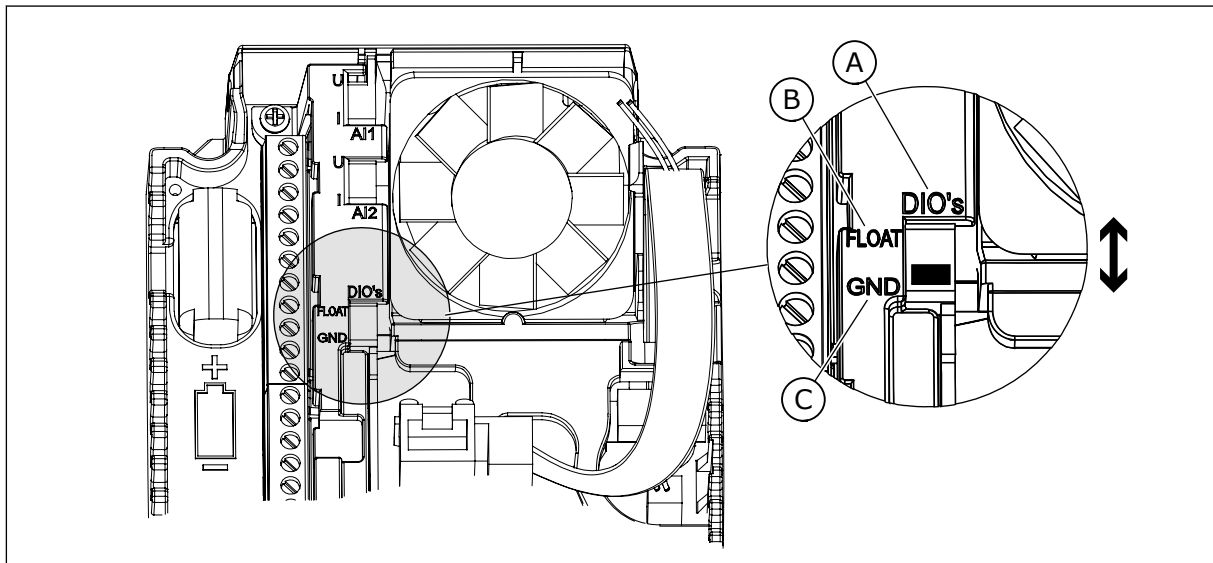

Fig. 11: The DIP switch

- A. Digital input DIP switch
- B. Floating

- C. Connected to GND (**Default**)

Table 11: M1.1 Wizards

Index	Parameter	Min	Max	Unit	Default	ID	Description
1.1.1	Startup wizard	0	1		0	1170	0 = Do not activate 1 = Activate  The selection Activate starts the Start-up wizard (see Chapter Table 1 The Start-up wizard).
1.1.3	Multi-pump Wizard	0	1		0	1671	The selection Activate starts the Multi-pump wizard (see Chapter 2.7 Multi-pump wizard).
1.1.4	Fire mode Wizard	0	1		0	1672	The selection Activate starts the Fire mode wizard (see Chapter 2.8 Fire mode wizard).

**Table 12: M1 Quick Setup**

Index	Parameter	Min	Max	Unit	Default	ID	Description
1.2	Application	0	5		3	212	0 = Standard 1 = Local/Remote 2 = Multi-Step Speed 3 = PID Control 4 = Multi-Purpose 5 = Motor Potentiometer
1.3	Minimum Frequency Reference	0.00	P1.4	Hz	0.0	101	
1.4	Maximum Frequency Reference	P1.3	320.0	Hz	50.0 / 60.0	102	
1.5	Acceleration Time 1	0.1	300.0	s	5.0	103	
1.6	Deceleration Time 1	0.1	300.0	s	5.0	104	
1.7	Motor Current Limit	I <sub>H</sub> *0.1	I <sub>S</sub>	A	Varies	107	
1.8	Motor Type	0	2		0	650	0 = Induction Motor 1 = Permanent Magnet Motor 2 = Reluctance Motor
1.9	Motor Nominal Voltage	Varies	Varies	V	Varies	110	Find this value U <sub>n</sub> on the nameplate of the motor. <b>NOTE!</b> Find out if the motor connection is Delta or Star.
1.10	Motor Nominal Frequency	8.0	320.0	Hz	50 / 60	111	Find this value f <sub>n</sub> on the nameplate of the motor.
1.11	Motor Nominal Speed	24	19200	Rpm	Varies	112	Find this value n <sub>n</sub> on the nameplate of the motor.
1.12	Motor Nominal Current	I <sub>H</sub> * 0.1	I <sub>H</sub> * 2	A	Varies	113	Find this value I <sub>n</sub> on the nameplate of the motor.
1.13	Motor Cos Phi (Power Factor)	0.30	1.00		Varies	120	Find this value on the nameplate of the motor.

**Table 12: M1 Quick Setup**

Index	Parameter	Min	Max	Unit	Default	ID	Description
1.14	Energy Optimization	0	1		0	666	0 = Disabled 1 = Enabled
1.15	Identification	0	2		0	631	0 = No action 1 = At standstill 2 = With rotation
1.16	Start Function	0	1		0	505	0 = Ramping 1 = Flying Start
1.17	Stop Function	0	1		0	506	0 = Coasting 1 = Ramping
1.18	Automatic Reset	0	1		0	731	0 = Disabled 1 = Enabled
1.19	Response to External Fault	0	3		2	701	0 = No action 1 = Alarm 2 = Fault (Stop according to stop mode) 3 = Fault (Stop by coasting)
1.20	Response to AI Low Fault	0	5		0	700	0 = No action 1 = Alarm 2 = Alarm+preset fault frequency (P3.9.1.13) 3 = Alarm + previous frequency 4 = Fault (Stop according to stop mode) 5 = Fault (Stop by coasting)
1.21	Remote Control Place	0	1		0	172	0 = I/O control 1 = Fieldbus control

**Table 12: M1 Quick Setup**

Index	Parameter	Min	Max	Unit	Default	ID	Description
1.22	I/O Control Reference A Selection	0	9		6	117	0 = Preset Frequency 1 = Keypad Reference 2 = Fieldbus 3 = AI1 4 = AI2 5 = AI1+AI2 6 = PID Reference 7 = Motor Potentiometer 8 = Joystick Reference 9 = Jogging Reference 10 = Block Out.1 11 = Block Out.2 12 = Block Out.3 13 = Block Out.4 14 = Block Out.5 15 = Block Out.6 16 = Block Out.7 17 = Block Out.8 18 = Block Out.9 19 = Block Out.10  The application that you set with parameter 1.2 gives the default value.
1.23	Keypad Control Reference Selection	0	9		1	121	See P1.22.
1.24	Fieldbus Control Reference Selection	0	9		2	122	See P1.22.
1.25	AI1 Signal Range	0	1		0	379	0= 0..10V / 0..20mA 1= 2..10V / 4..20mA
1.26	AI2 Signal Range	0	1		1	390	0= 0..10V / 0..20mA 1= 2..10V / 4..20mA
1.27	R01 Function	0	51		2	1101	See P3.5.3.2.1
1.28	R02 Function	0	51		3	1104	See P3.5.3.2.1
1.29	R03 Function	0	51		1	1107	See P3.5.3.2.1
1.30	A01 Function	0	31		2	10050	See P3.5.4.1.1

**Table 13: M1.34 PID control**

Index	Parameter	Min	Max	Unit	Default	ID	Description
1.34.1	PID Gain	0.00	100.00	%	100.00	18	
1.34.2	PID Integration Time	0.00	600.00	s	1.00	119	
1.34.3	PID Derivation Time	0.00	100.00	s	0.00	1132	
1.34.4	Feedback 1 Source Selection	0	30		2	334	See P3.13.3.3
1.34.5	Setpoint 1 Source Selection	0	32		1	332	See P3.13.2.6
1.34.6	Keypad Setpoint 1	Varies	Varies	Varies	0	167	
1.34.7	Sleep Frequency Limit 1	0.0	320.0	Hz	0.0	1016	
1.34.8	Sleep Delay 1	0	3000	s	0	1017	
1.34.9	Wake-up Level 1	Varies	Varies	Varies	Varies	1018	
1.34.10	Preset Frequency 1	P1.3	P1.4	Hz	10.0	105	

#### 1.4.5 MULTI-PURPOSE APPLICATION

You can use the Multi-purpose application for different processes (for example conveyors) where a wide range of motor control functions is necessary.

It is possible to control the drive from the keypad, Fieldbus or I/O terminal. When you use I/O terminal control, the start/stop commands are given through DI1 and DI2, and the frequency reference from AI1 or AI2.

There are 2 acceleration/deceleration ramps available. The selection between Ramp1 and Ramp2 is made by DI6.

It is possible to configure all the drive outputs freely in all the applications. There are 1 analogue output (Output Frequency) and 3 relay outputs (Run, Fault, Ready) available on the basic I/O board.

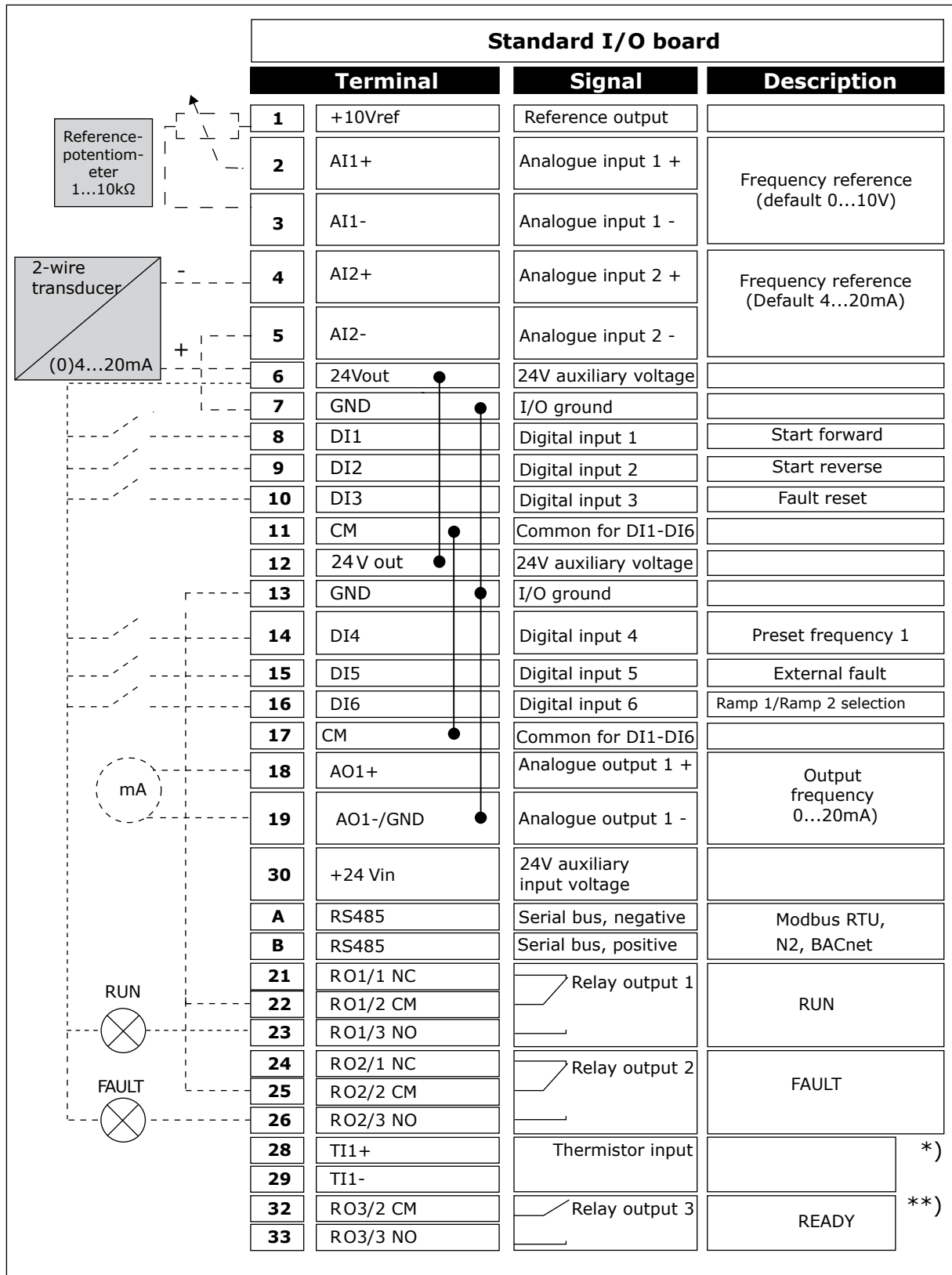

Fig. 12: The default control connections of the Multi-purpose application

\* = Available only in Vacon 100 X.



\*\* = For the DIP switch configurations in Vacon 100 X, see the Vacon 100 X Installation manual.

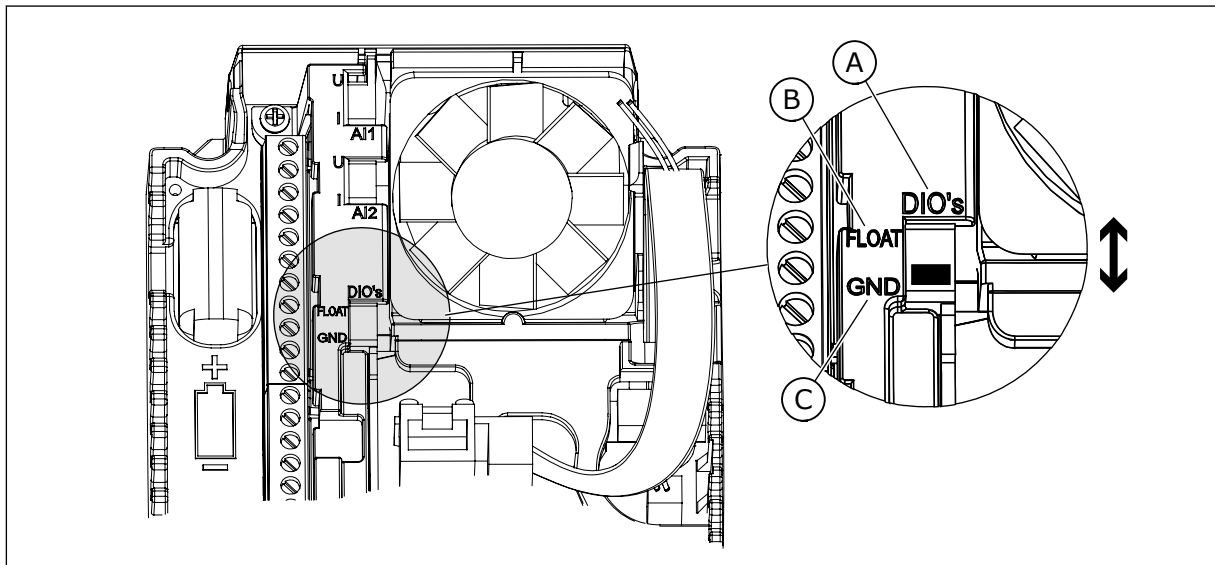

Fig. 13: The DIP switch

- A. Digital input DIP switch
- B. Floating

- C. Connected to GND (**Default**)

Table 14: M1.1 Wizards

Index	Parameter	Min	Max	Unit	Default	ID	Description
1.1.1	Startup wizard	0	1		0	1170	0 = Do not activate 1 = Activate  The selection Activate starts the Start-up wizard (see Chapter Table 1 The Start-up wizard).
1.1.3	Multi-pump Wizard	0	1		0	1671	The selection Activate starts the Multi-pump wizard (see Chapter 2.7 Multi-pump wizard).
1.1.4	Fire mode Wizard	0	1		0	1672	The selection Activate starts the Fire mode wizard (see Chapter 2.8 Fire mode wizard).

**Table 15: M1 Quick Setup**

Index	Parameter	Min	Max	Unit	Default	ID	Description
1.2	Application	0	5		4	212	0 = Standard 1 = Local/Remote 2 = Multi-Step Speed 3 = PID Control 4 = Multi-Purpose 5 = Motor Potentiometer
1.3	Minimum Frequency Reference	0.00	P1.4	Hz	0.0	101	
1.4	Maximum Frequency Reference	P1.3	320.0	Hz	50.0 / 60.0	102	
1.5	Acceleration Time 1	0.1	300.0	s	5.0	103	
1.6	Deceleration Time 1	0.1	300.0	s	5.0	104	
1.7	Motor Current Limit	I <sub>H</sub> *0.1	I <sub>S</sub>	A	Varies	107	
1.8	Motor Type	0	2		0	650	0 = Induction Motor 1 = Permanent Magnet Motor 2 = Reluctance Motor
1.9	Motor Nominal Voltage	Varies	Varies	V	Varies	110	Find this value U <sub>n</sub> on the nameplate of the motor. <b>NOTE!</b> Find out if the motor connection is Delta or Star.
1.10	Motor Nominal Frequency	8.0	320.0	Hz	50 / 60	111	Find this value f <sub>n</sub> on the nameplate of the motor.
1.11	Motor Nominal Speed	24	19200	Rpm	Varies	112	Find this value n <sub>n</sub> on the nameplate of the motor.
1.12	Motor Nominal Current	I <sub>H</sub> * 0.1	I <sub>H</sub> * 2	A	Varies	113	Find this value I <sub>n</sub> on the nameplate of the motor.
1.13	Motor Cos Phi (Power Factor)	0.30	1.00		Varies	120	Find this value on the nameplate of the motor.

**Table 15: M1 Quick Setup**

Index	Parameter	Min	Max	Unit	Default	ID	Description
1.14	Energy Optimization	0	1		0	666	0 = Disabled 1 = Enabled
1.15	Identification	0	2		0	631	0 = No action 1 = At standstill 2 = With rotation
1.16	Start Function	0	1		0	505	0 = Ramping 1 = Flying Start
1.17	Stop Function	0	1		0	506	0 = Coasting 1 = Ramping
1.18	Automatic Reset	0	1		0	731	0 = Disabled 1 = Enabled
1.19	Response to External Fault	0	3		2	701	0 = No action 1 = Alarm 2 = Fault (Stop according to stop mode) 3 = Fault (Stop by coasting)
1.20	Response to AI Low Fault	0	5		0	700	0 = No action 1 = Alarm 2 = Alarm+preset fault frequency (P3.9.1.13) 3 = Alarm + previous frequency 4 = Fault (Stop according to stop mode) 5 = Fault (Stop by coasting)
1.21	Remote Control Place	0	1		0	172	0 = I/O control 1 = Fieldbus control

**Table 15: M1 Quick Setup**

Index	Parameter	Min	Max	Unit	Default	ID	Description
1.22	I/O Control Reference A Selection	0	9		5	117	0 = Preset Frequency 1 = Keypad Reference 2 = Fieldbus 3 = AI1 4 = AI2 5 = AI1+AI2 6 = PID Reference 7 = Motor Potentiometer 8 = Joystick Reference 9 = Jogging Reference 10 = Block Out.1 11 = Block Out.2 12 = Block Out.3 13 = Block Out.4 14 = Block Out.5 15 = Block Out.6 16 = Block Out.7 17 = Block Out.8 18 = Block Out.9 19 = Block Out.10  The application that you set with parameter 1.2 gives the default value.
1.23	Keypad Control Reference Selection	0	9		1	121	See P1.22.
1.24	Fieldbus Control Reference Selection	0	9		2	122	See P1.22.
1.25	AI1 Signal Range	0	1		0	379	0= 0..10V / 0..20mA 1= 2..10V / 4..20mA
1.26	AI2 Signal Range	0	1		0	390	0= 0..10V / 0..20mA 1= 2..10V / 4..20mA
1.27	R01 Function	0	51		2	1101	See P3.5.3.2.1
1.28	R02 Function	0	51		3	1104	See P3.5.3.2.1
1.29	R03 Function	0	51		1	1107	See P3.5.3.2.1
1.30	A01 Function	0	31		2	10050	See P3.5.4.1.1

**Table 16: M1.35 Multi-purpose**

Index	Parameter	Min	Max	Unit	Default	ID	Description
1.35.1	Control Mode	0	2		0	600	0 = U/f Freq Control open loop 1 = Speed control open loop 2 = Torque Control open loop
1.35.2	Auto Torque Boost	0	1		0	109	0 = Disabled 1 = Enabled
1.35.3	Acceleration Time 2	0.1	300.0	s	10.0	502	
1.35.4	Deceleration Time 2	0.1	300.0	s	10.0	503	
1.35.5	Preset Frequency 1	P1.3	P1.4	Hz	5.0	105	
1.35.6	U/f Ratio Select	0	2		0	108	0 = Linear 1 = Squared 2 = Programmable
1.35.7	Field Weakening Point Frequency	8.00	P1.4	Hz	Varies	602	
1.35.8	Voltage at Field Weakening Point	10.00	200.00	%	100.00	603	
1.35.9	U/f Midpoint Frequency	0.0	P1.35.7	Hz	Varies	604	
1.35.10	U/f Midpoint Voltage	0.0	100.00	%	100.0	605	
1.35.11	Zero Frequency Voltage	0.00	40.00	%	Varies	606	
1.35.12	Start Magnetizing Current	0.00	Varies	A	Varies	517	
1.35.13	Start Magnetizing Time	0.00	600.00	s	0.00	516	
1.35.14	DC Brake Current	Varies	Varies	A	Varies	507	0 = Disabled
1.35.15	DC Braking time at stop	0.00	600.00	s	0.00	508	
1.35.16	Frequency to start DC braking at ramp stop	0.10	50.00	%	0.00	515	

**Table 16: M1.35 Multi-purpose**

Index	Parameter	Min	Max	Unit	Default	ID	Description
1.35.17	Load Drooping	0.00	50.00	%	0.00	620	
1.35.18	Load Drooping Time	0.00	2.00	s	0.00	656	
1.35.19	Load Drooping Mode	0	1		0	1534	0 = Normal; Load drooping factor is constant through the whole frequency range 1 = Linear removal; Load drooping is removed linearly from nominal frequency to zero frequency

#### 1.4.6 MOTOR POTENTIOMETER APPLICATION

Use the Motor potentiometer application for the processes where the frequency reference of the motor is controlled (that is, increased and decreased) through digital inputs.

In this application, the I/O terminal is set to the default control place. the start/stop commands are given with DI1 and DI2. The frequency reference of the motor is increased with DI5 and decreased with DI6.

It is possible to configure all the drive outputs freely in all the applications. There are 1 analogue output (Output Frequency) and 3 relay outputs (Run, Fault, Ready) available on the basic I/O board.

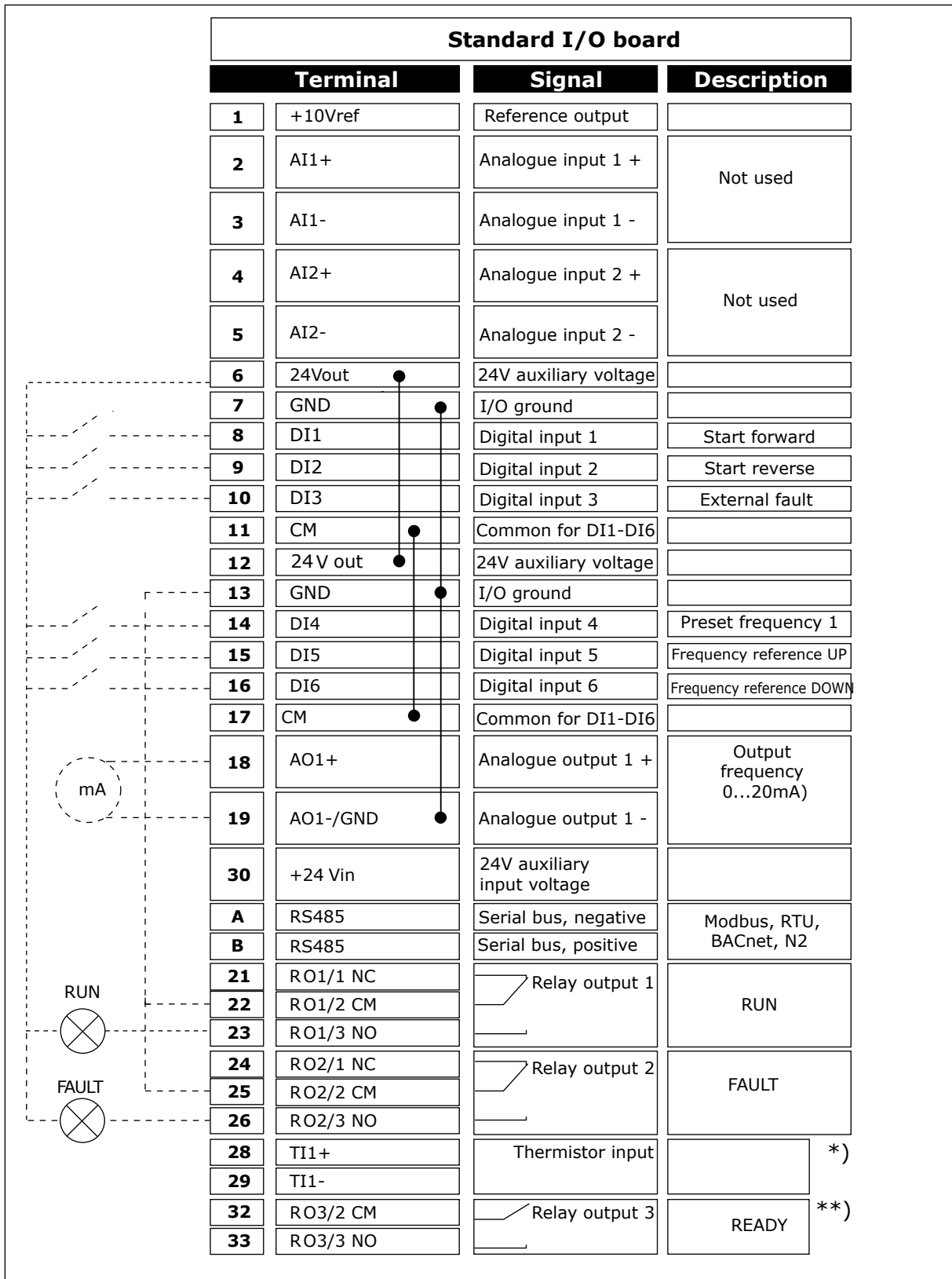

Fig. 14: The default control connections of the Motor potentiometer application

\* = Available only in Vacon 100 X.

\*\* = For the DIP switch configurations in Vacon 100 X, see the Vacon 100 X Installation manual.

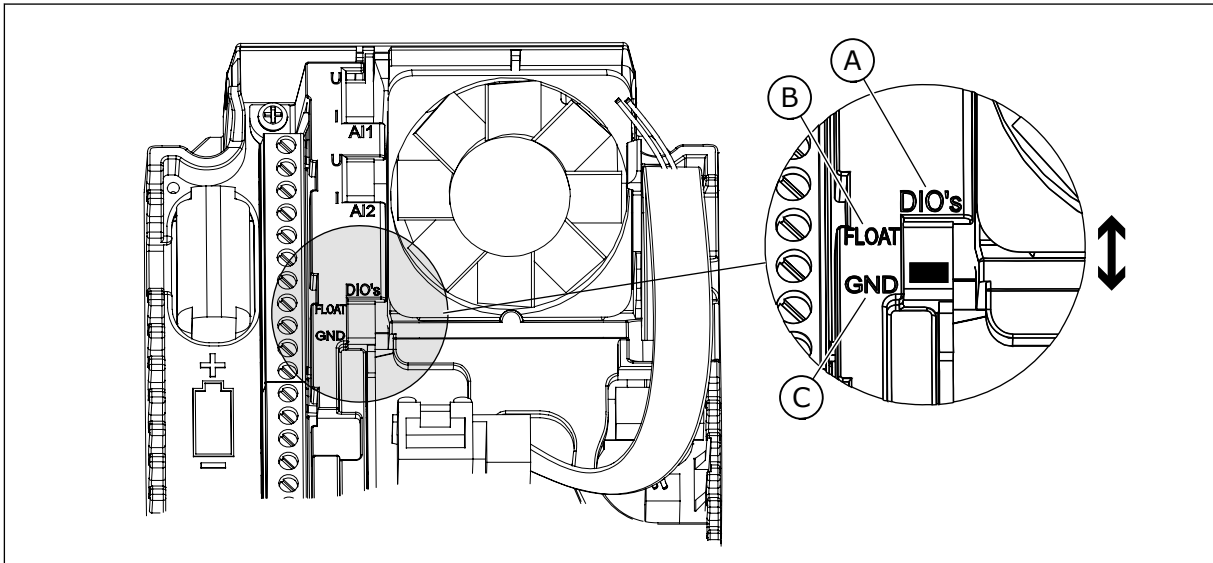

Fig. 15: The DIP switch

- A. Digital input DIP switch
- B. Floating

- C. Connected to GND (**Default**)

Table 17: M1.1 Wizards

Index	Parameter	Min	Max	Unit	Default	ID	Description
1.1.1	Startup wizard	0	1		0	1170	0 = Do not activate 1 = Activate  The selection Activate starts the Start-up wizard (see Chapter Table 1 The Start-up wizard).
1.1.3	Multi-pump Wizard	0	1		0	1671	The selection Activate starts the Multi-pump wizard (see Chapter 2.7 Multi-pump wizard).
1.1.4	Fire mode Wizard	0	1		0	1672	The selection Activate starts the Fire mode wizard (see Chapter 2.8 Fire mode wizard).



**Table 18: M1 Quick Setup**

Index	Parameter	Min	Max	Unit	Default	ID	Description
1.2	Application	0	5		5	212	0 = Standard 1 = Local/Remote 2 = Multi-Step Speed 3 = PID Control 4 = Multi-Purpose 5 = Motor Potentiometer
1.3	Minimum Frequency Reference	0.00	P1.4	Hz	0.0	101	
1.4	Maximum Frequency Reference	P1.3	320.0	Hz	50.0 / 60.0	102	
1.5	Acceleration Time 1	0.1	300.0	s	5.0	103	
1.6	Deceleration Time 1	0.1	300.0	s	5.0	104	
1.7	Motor Current Limit	I <sub>H</sub> *0.1	I <sub>S</sub>	A	Varies	107	
1.8	Motor Type	0	2		0	650	0 = Induction Motor 1 = Permanent Magnet Motor 2 = Reluctance Motor
1.9	Motor Nominal Voltage	Varies	Varies	V	Varies	110	Find this value U <sub>n</sub> on the nameplate of the motor. <b>NOTE!</b> Find out if the motor connection is Delta or Star.
1.10	Motor Nominal Frequency	8.0	320.0	Hz	50 / 60	111	Find this value f <sub>n</sub> on the nameplate of the motor.
1.11	Motor Nominal Speed	24	19200	Rpm	Varies	112	Find this value n <sub>n</sub> on the nameplate of the motor.
1.12	Motor Nominal Current	I <sub>H</sub> * 0.1	I <sub>H</sub> * 2	A	Varies	113	Find this value I <sub>n</sub> on the nameplate of the motor.
1.13	Motor Cos Phi (Power Factor)	0.30	1.00		Varies	120	Find this value on the nameplate of the motor.

**Table 18: M1 Quick Setup**

Index	Parameter	Min	Max	Unit	Default	ID	Description
1.14	Energy Optimization	0	1		0	666	0 = Disabled 1 = Enabled
1.15	Identification	0	2		0	631	0 = No action 1 = At standstill 2 = With rotation
1.16	Start Function	0	1		0	505	0 = Ramping 1 = Flying Start
1.17	Stop Function	0	1		0	506	0 = Coasting 1 = Ramping
1.18	Automatic Reset	0	1		0	731	0 = Disabled 1 = Enabled
1.19	Response to External Fault	0	3		2	701	0 = No action 1 = Alarm 2 = Fault (Stop according to stop mode) 3 = Fault (Stop by coasting)
1.20	Response to AI Low Fault	0	5		0	700	0 = No action 1 = Alarm 2 = Alarm+preset fault frequency (P3.9.1.13) 3 = Alarm + previous frequency 4 = Fault (Stop according to stop mode) 5 = Fault (Stop by coasting)
1.21	Remote Control Place	0	1		0	172	0 = I/O control 1 = Fieldbus control

**Table 18: M1 Quick Setup**

Index	Parameter	Min	Max	Unit	Default	ID	Description
1.22	I/O Control Reference A Selection	0	9		7	117	0 = Preset Frequency 1 = Keypad Reference 2 = Fieldbus 3 = AI1 4 = AI2 5 = AI1+AI2 6 = PID Reference 7 = Motor Potentiometer 8 = Joystick Reference 9 = Jogging Reference 10 = Block Out.1 11 = Block Out.2 12 = Block Out.3 13 = Block Out.4 14 = Block Out.5 15 = Block Out.6 16 = Block Out.7 17 = Block Out.8 18 = Block Out.9 19 = Block Out.10  The application that you set with parameter 1.2 gives the default value.
1.23	Keypad Control Reference Selection	0	9		1	121	See P1.22.
1.24	Fieldbus Control Reference Selection	0	9		2	122	See P1.22.
1.25	AI1 Signal Range	0	1		0	379	0= 0..10V / 0..20mA 1= 2..10V / 4..20mA
1.26	AI2 Signal Range	0	1		1	390	0= 0..10V / 0..20mA 1= 2..10V / 4..20mA
1.27	R01 Function	0	51		2	1101	See P3.5.3.2.1
1.28	R02 Function	0	51		3	1104	See P3.5.3.2.1
1.29	R03 Function	0	51		1	1107	See P3.5.3.2.1
1.30	A01 Function	0	31		2	10050	See P3.5.4.1.1

**Table 19: M1.36 Motor Potentiometer**

Index	Parameter	Min	Max	Unit	Default	ID	Description
1.36.1	Motor Potentiometer Ramp Time	0.1	500.0	Hz/s	10.0	331	
1.31.2	Motor Potentiometer Reset	0	2		1	367	0 = No reset 1 = Reset if stopped 2 = Reset if powered down
1.31.2	Preset Frequency 1	P1.3	P1.4	Hz	10.0	105	

## 2 WIZARDS

### 2.1 STANDARD APPLICATION WIZARD

The application wizard helps you to set the basic parameters that are related to the application.

To start the Standard application wizard, set the value *Standard* to parameter P1.2 Application (ID 212) in the keypad.



#### NOTE!

If you start the application wizard from the Start-up wizard, the wizard goes directly to step 11.

1	Set a value for P3.1.2.2 Motor Type (so that it agrees with the nameplate of the motor)	PM motor Induction motor Reluctance motor
2	Set a value for P3.1.1.1 Motor Nominal Voltage (so that it agrees with the nameplate of the motor)	Range: Varies
3	Set a value for P3.1.1.2 Motor Nominal Frequency (so that it agrees with the nameplate of the motor)	Range: 8.00...320.00 Hz
4	Set a value for P3.1.1.3 Motor Nominal Speed (so that it agrees with the nameplate of the motor)	Range: 24...19200 rpm
5	Set a value for P3.1.1.4 Motor Nominal Current (so that it agrees with the nameplate of the motor)	Range: Varies

If you set Motor Type to *Induction Motor*, you see the next step. If your selection is *PM Motor*, the value of parameter P3.1.1.5 Motor Cos Phi is set to 1.00, and the wizard goes directly to step 7.

6	Set a value for P3.3.1.5 Motor Cos Phi (so that it agrees with the nameplate of the motor)	Range: 0.3...1.00
7	Set a value for P3.3.1.1 Minimum Frequency Reference	Range: 0.00...P3.3.1.2 Hz
8	Set a value for P3.3.1.1 Maximum Frequency Reference	Range: P3.3.1.1...320.00 Hz
9	Set a value for P3.4.1.2 Acceleration Time 1	Range: 0.1...300.0 s
10	Set a value for P3.4.1.2 Deceleration Time 1	Range: 0.1...300.0 s
11	Make a selection of a control place (where you give the start and stop commands, and the frequency reference of the drive)	I/O terminal Fieldbus Keypad

The Standard application wizard is completed.

## 2.2 LOCAL/REMOTE APPLICATION WIZARD

The application wizard helps you to set the application related basic parameters.

To start the Local/Remote application wizard, set the value *Local/Remote* to parameter P1.2 Application (ID 212) in the keypad.



### NOTE!

If you start the application wizard from the Start-up wizard, the wizard goes directly to step 11.

1	Set a value for P3.1.2.2 Motor Type (so that it agrees with the nameplate of the motor)	PM motor Induction motor Reluctance motor
2	Set a value for P3.1.1.1 Motor Nominal Voltage (so that it agrees with the nameplate of the motor)	Range: Varies
3	Set a value for P3.1.1.2 Motor Nominal Frequency (so that it agrees with the nameplate of the motor)	Range: 8.00...320.00 Hz
4	Set a value for P3.1.1.3 Motor Nominal Speed (so that it agrees with the nameplate of the motor)	Range: 24...19200 rpm
5	Set a value for P3.1.1.4 Motor Nominal Current (so that it agrees with the nameplate of the motor)	Range: Varies

If you set Motor Type to *Induction Motor*, you see the next step. If your selection is *PM Motor*, the value of parameter P3.1.1.5 Motor Cos Phi is set to 1.00, and the wizard goes directly to step 7.

6	Set a value for P3.1.1.5 Motor Cos Phi (so that it agrees with the nameplate of the motor)	Range: 0.30...1.00
7	Set a value for P3.3.1.1 Minimum Frequency Reference	Range: 0.00...P3.3.1.2 Hz
8	Set a value for P3.3.1.2 Maximum Frequency Reference	Range: P3.3.1.1...320.00 Hz
9	Set a value for P3.4.1.2 Acceleration Time 1	Range: 0.1...300.0 s
10	Set a value for P3.4.1.3 Deceleration Time 1	Range: 0.1...300.0 s
11	Make a selection of the Remote control place (where you give the start and stop commands, and the frequency reference of the drive when Remote control is active)	I/O terminal Fieldbus

If you set *I/O Terminal* as the value for Remote Control Place, you see the next step. If you set *Fieldbus*, the wizard goes directly to step 14.

12	P1.26 Analogue Input 2 Signal Range	0=0...10V / 0...20mA 1=2...10V / 4...20mA
13	Set Local Control Place (where the drive start/stop commands and the frequency reference is given when Local control is active)	Fieldbus Keypad I/O (B) terminal

If you set *I/O (B) Terminal* as the value for Local Control Place, you see the next step. With other selections, the wizard goes directly to step 16.

14	P1.25 Analogue Input 1 Signal Range	0=0...10V / 0...20mA 1=2...10V / 4...20mA
----	-------------------------------------	----------------------------------------------

The Local/Remote application wizard is completed.

## 2.3 MULTI-STEP SPEED APPLICATION WIZARD

The application wizard helps you to set the basic parameters that are related to the application.

To start the Multi-step speed application wizard, set the value *Multi-step speed* to parameter P1.2 Application (ID 212) in the keypad.



### NOTE!

If you start the application wizard from the Start-up wizard, the wizard shows only the I/O configuration.

1	Set a value for P3.1.2.2 Motor Type (so that it agrees with the nameplate of the motor)	PM motor Induction motor Reluctance motor
2	Set a value for P3.1.1.1 Motor Nominal Voltage (so that it agrees with the nameplate of the motor)	Range: Varies
3	Set a value for P3.1.1.2 Motor Nominal Frequency (so that it agrees with the nameplate of the motor)	Range: 8.00...320.00 Hz
4	Set a value for P3.1.1.3 Motor Nominal Speed (so that it agrees with the nameplate of the motor)	Range: 24...19200 rpm
5	Set a value for P3.1.1.4 Motor Nominal Current (so that it agrees with the nameplate of the motor)	Range: Varies

If you set Motor Type to *Induction Motor*, you see the next step. If your selection is *PM Motor*, the value of parameter P3.1.1.5 Motor Cos Phi is set to 1.00, and the wizard goes directly to step 7.

6	Set a value for P3.1.1.5 Motor Cos Phi (so that it agrees with the nameplate of the motor)	Range: 0.30...1.00
7	Set a value for P3.3.1.1 Minimum Frequency Reference	Range: 0.00...P3.3.1.2 Hz
8	Set a value for P3.3.1.2 Maximum Frequency Reference	Range: P3.3.1.1...320.00 Hz
9	Set a value for P3.4.1.2 Acceleration Time 1	Range: 0.1...300.0 s
10	Set a value for P3.4.1.3 Deceleration Time 1	Range: 0.1...300.0 s

The Multi-step speed application wizard is completed.

## 2.4 PID CONTROL APPLICATION WIZARD

The application wizard helps you to set the basic parameters that are related to the application.

To start the PID control application wizard, set the value *PID control* to parameter P1.2 Application (ID 212) in the keypad.



### NOTE!

If you start the application wizard from the startup wizard, the wizard goes directly to step 11.



1	Set a value for P3.1.2.2 Motor Type (so that it agrees with the nameplate of the motor)	PM motor Induction motor Reluctance motor
2	Set a value for P3.1.1.1 Motor Nominal Voltage (so that it agrees with the nameplate of the motor)	Range: Varies
3	Set a value for P3.1.1.2 Motor Nominal Frequency (so that it agrees with the nameplate of the motor)	Range: 8.00...320.00 Hz
4	Set a value for P3.1.1.3 Motor Nominal Speed (so that it agrees with the nameplate of the motor)	Range: 24...19200 rpm
5	Set a value for P3.1.1.4 Motor Nominal Current (so that it agrees with the nameplate of the motor)	Range: Varies

If you set Motor Type to *Induction Motor*, you see the next step. If your selection is *PM Motor*, the value of parameter P3.1.1.5 Motor Cos Phi is set to 1.00, and the wizard goes directly to step 7.

6	Set a value for P3.1.1.5 Motor Cos Phi (so that it agrees with the nameplate of the motor)	Range: 0.30...1.00
7	Set a value for P3.3.1.1 Minimum Frequency Reference	Range: 0.00 Hz...P3.3.1.2
8	Set a value for P3.3.1.2 Maximum Frequency Reference	Range: P3.3.1.1...320.00 Hz
9	Set a value for P3.4.1.2 Acceleration Time 1	Range: 0.1...300.0 s
10	Set a value for P3.4.1.3 Deceleration Time 1	Range: 0.1...300.0 s
11	Make a selection of a control place (where you give the start/stop commands)	I/O Terminal Fieldbus Keypad
12	Set a value for P3.13.1.4 Process Unit Selection	More than 1 selection

If your selection is other than %, you see the next steps. If your selection is %, the wizard goes directly to step 17.

13	Set a value for P3.13.1.5 Process Unit Min	The range depends on the selection in step 12.
14	Set a value for P3.13.1.6 Process Unit Max	The range depends on the selection in step 12.
15	Set a value for P3.13.1.7 Process Unit Decimals	Range: 0...4
16	Set a value for P3.13.3.3 Feedback 1 Source Selection	See the table Feedback settings in Chapter 5.13 Group 3.13: PID controller

If you make a selection of an analogue input signal, you see step 18. With other selections, the wizard goes to step 19.

<b>17</b>	Set the signal range of the analogue input	0 = 0...10V / 0...20mA 1 = 2...10V / 4...20mA
<b>18</b>	Set a value for P3.13.1.8 Error Inversion	0 = Normal 1 = Inverted
<b>19</b>	Set a value for P3.13.2.6 Setpoint Source Selection	See table Setpoints in Chapter 5.13 Group 3.13: PID controller

If you make a selection of an analogue input signal, you see step 21. With other selections, the wizard goes to step 23.

If you set *Keypad Setpoint 1* or *Keypad Setpoint 2* for the value, the wizard goes directly to step 22.

<b>20</b>	Set the signal range of the analogue input	0 = 0...10V / 0...20mA 1 = 2...10V / 4...20mA
<b>21</b>	Set a value for P3.13.2.1 (Keypad Setpoint 1) and P3.13.2.2 (Keypad Setpoint 2)	Depends on the range set in step 20.
<b>22</b>	Using the sleep function	0 = No 1 = Yes

If you give the value *Yes* for step 22, you see the next 3 steps. If you give the value *No*, the wizard is completed.

<b>23</b>	Set a value for P3.34.7 Sleep Frequency Limit	Range: 0.00...320.00 Hz
<b>24</b>	Set a value for P3.34.8 Sleep Delay 1	Range: 0...3000 s
<b>25</b>	Set a value for P3.34.9 Wake-up Level	The range depends on the set process unit

The PID Control application wizard is completed.

## 2.5 MULTI-PURPOSE APPLICATION WIZARD

The application wizard helps you to set the basic parameters that are related to the application.

To start the Multi-purpose application wizard, set the value *Multi-purpose* to parameter P1.2 Application (ID 212) in the keypad.

**NOTE!**

If you start the application wizard from the Start-up wizard, the wizard goes directly to step 11.

1	Set a value for P3.1.2.2 Motor Type (so that it agrees with the nameplate of the motor)	PM motor Induction motor Reluctance motor
2	Set a value for P3.1.1.1 Motor Nominal Voltage (so that it agrees with the nameplate of the motor)	Range: Varies
3	Set a value for P3.1.1.2 Motor Nominal Frequency (so that it agrees with the nameplate of the motor)	Range: 8.00...320.00 Hz
4	Set a value for P3.1.1.3 Motor Nominal Speed (so that it agrees with the nameplate of the motor)	Range: 24...19200 rpm
5	Set a value for P3.1.1.4 Motor Nominal Current (so that it agrees with the nameplate of the motor)	Range: Varies

If you set Motor Type to *Induction Motor*, you see the next step. If your selection is *PM Motor*, the value of parameter P3.1.1.5 Motor Cos Phi is set to 1.00, and the wizard goes directly to step 7.

6	Set a value for P3.1.1.5 Motor Cos Phi (so that it agrees with the nameplate of the motor)	Range: 0.30...1.00
7	Set a value for P3.3.1.1 Minimum Frequency Reference	Range: 0.00...P3.3.1.2 Hz
8	Set a value for P3.3.1.2 Maximum Frequency Reference	Range: P3.3.1.1...320.00 Hz
9	Set a value for P3.4.1.2 Acceleration Time 1	Range: 0.1...300.0 s
10	Set a value for P3.4.1.3 Deceleration Time 1	Range: 0.1...300.0 s
11	Select Control Place (where you give the start and stop commands, and the frequency reference of the drive)	I/O Terminal Fieldbus Keypad

The Multi-purpose application wizard is completed.

## 2.6 MOTOR POTENTIOMETER APPLICATION WIZARD

The application wizard helps you to set the application related basic parameters.

To start the Motor potentiometer application wizard, set the value *Motor potentiometer* to parameter P1.2 Application (ID 212) in the keypad.

**NOTE!**

If you start the application wizard from the Start-up wizard, the wizard goes directly to step 11.

1	Set a value for P3.1.2.2 Motor Type (so that it agrees with the nameplate of the motor)	PM motor Induction motor Reluctance motor
2	Set a value for P3.1.1.1 Motor Nominal Voltage (so that it agrees with the nameplate of the motor)	Range: Varies
3	Set a value for P3.1.1.2 Motor Nominal Frequency (so that it agrees with the nameplate of the motor)	Range: 8.00...320.00 Hz
4	Set a value for P3.1.1.3 Motor Nominal Speed (so that it agrees with the nameplate of the motor)	Range: 24...19200 rpm
5	Set a value for P3.1.1.4 Motor Nominal Current (so that it agrees with the nameplate of the motor)	Range: Varies

If you set Motor Type to *Induction Motor*, you see the next step. If your selection is *PM Motor*, the value of parameter P3.1.1.5 Motor Cos Phi is set to 1.00, and the wizard goes directly to step 7.

6	Set a value for P3.1.1.5 Motor Cos Phi (so that it agrees with the nameplate of the motor)	Range: 0.30...1.00
7	Set a value for P3.3.1.1 Minimum Frequency Reference	Range: 0.00...P3.3.1.2 Hz
8	Set a value for P3.3.1.2 Maximum Frequency Reference	Range: P3.3.1.1...320.00 Hz
9	Set a value for P3.4.1.2 Acceleration Time 1	Range: 0.1...300.0 s
10	Set a value for P3.4.1.3 Deceleration Time 1	Range: 0.1...300.0 s
11	Set a value for P1.36.1 Motor Potentiometer Ramp Time	Range: 0.1...500.0 Hz/s
12	Set a value for P1.36.2 Motor Potentiometer Reset	0 = No Reset 1 = Stop State 2 = Power Down

The Motor Potentiometer application wizard is completed.

## 2.7 MULTI-PUMP WIZARD

To start the Multi-pump wizard, make the selection *Activate* for parameter B1.1.3 in the Quick setup menu. The default settings tell you to use the PID controller in the one

feedback / one setpoint mode. The default control place is I/O A, and the default process unit is %.

<b>1</b>	Set a value for P3.13.1.4 Process Unit Selection	More than 1 selection.
----------	--------------------------------------------------	------------------------

If your selection is other than %, you see the next steps. If your selection is %, the wizard goes directly to step 5.

<b>2</b>	Set a value for P3.13.1.5 Process Unit Min	Varies
<b>3</b>	Set a value for P3.13.1.6 Process Unit Max	Varies
<b>4</b>	Set a value for P3.13.1.7 Process Unit Decimals	0...4
<b>5</b>	Set a value for P3.13.3.3 Feedback 1 Source Selection	See the table Feedback settings in Chapter 5.13 Group 3.13: PID controller.

If you make a selection of an analogue input signal, you see step 6. With other selections, the wizard goes to step 7.

<b>6</b>	Set the signal range of the analogue input	0 = 0...10V / 0...20mA 1 = 2...10V / 4...20mA See table Analogue inputs in Chapter 5.5 Group 3.5: I/O configuration.
<b>7</b>	Set a value for P3.13.1.8 Error Inversion	0 = Normal 1 = Inverted
<b>8</b>	Set a value for P3.13.2.6 Setpoint Source 1 Selection	See table Setpoints in Chapter 5.13 Group 3.13: PID controller.

If you make a selection of an analogue input signal, you see step 9. With other selections, the wizard goes to step 11.

If you set *Keypad Setpoint 1* or *Keypad Setpoint 2* for the value, you see step 10.

<b>9</b>	Set the signal range of the analogue input	0 = 0...10V / 0...20mA 1 = 2...10V / 4...20mA See table Analogue inputs in Chapter 5.5 Group 3.5: I/O configuration.
<b>10</b>	Set a value for P3.13.2.1 (Keypad setpoint 1) and P3.13.2.2 (Keypad setpoint 2)	Varies
<b>11</b>	Using the sleep function	No Yes

If you give the value *Yes* in step 11, you see the next 3 steps.

12	Set a value for P3.13.5.1 Sleep Frequency Limit 1	0.00...320.00 Hz
13	Set a value for P3.13.5.2 Sleep Delay 1	0...3000 s
14	Set a value for P3.13.5.6 Wake-up Level 1	The range depends on the set process unit.
15	Set a value for P3.15.1 Number of Motors	1...6
16	Set a value for P3.15.2 Interlock Function	0 = Not used 1 = Enabled
17	Set a value for P3.15.4 Autochange	0 = Disabled 1 = Enabled

If you enable the Autochange function, you see the next 3 steps. If you do not use the Autochange function, the wizard goes directly to step 21.

18	Set a value for P3.15.3 Include FC	0 = Disabled 1 = Enabled
19	Set a value for P3.15.5 Autochange Interval	0.0...3000.0 h
20	Set a value for P3.15.6 Autochange: Frequency Limit	0.00...50.00 Hz
21	Set a value for P3.15.8 Bandwidth	0...100%
22	Set a value for P3.15.9 Bandwidth Delay	0...3600 s

After this, the display will show the digital input and relay output configuration that the application does automatically. Write these values down. This function is not available in the text display.

## 2.8 FIRE MODE WIZARD

To start the Fire Mode Wizard, make the selection *Activate* for parameter B1.1.4 in the Quick setup menu.



### CAUTION!

Before you continue, read about the password and warranty in Chapter 10.18 *Fire mode*.

1	Set a value for parameter P3.17.2 Fire Mode Frequency Source	More than 1 selection
---	--------------------------------------------------------------	-----------------------

If you set a value other than *Fire mode frequency*, the wizard goes directly to step 3.

2	Set a value for parameter P3.17.3 Fire Mode Frequency	8.00 Hz...P3.3.1.2 (MaxFreqRef)
3	Activate the signal when the contact opens or when it closes	0 = Open contact 1 = Closed contact
4	Set a value for parameters P3.17.4 Fire Mode Activation on OPEN / P3.17.5 Fire Mode Activation on CLOSE	Make a selection of a digital input to activate Fire mode. See also Chapter 10.6.1 <i>Programming of digital and analogue inputs.</i>
5	Set a value for parameter P3.17.6 Fire Mode Reverse	Make a selection of a digital input to activate the reverse direction in Fire mode.  DigIn Slot0.1 = FORWARD DigIn Slot0.2 = REVERSE
6	Set a value for P3.17.1 Fire Mode Password	Set a password to enable the Fire mode function.  1234 = Enable test mode 1002 = Enable Fire mode

## **3 USER INTERFACES**

### **3.1 NAVIGATION ON THE KEYPAD**

The data of the AC drive is in menus and submenus. To move between the menus, use the arrow buttons Up and Down in the keypad. To go into a group or an item, push the OK button. To go back to the level where you were before, push the Back/Reset button.

On the display, you see your current location in the menu, for example M3.2.1. You also see the name of the group or item in your current location.



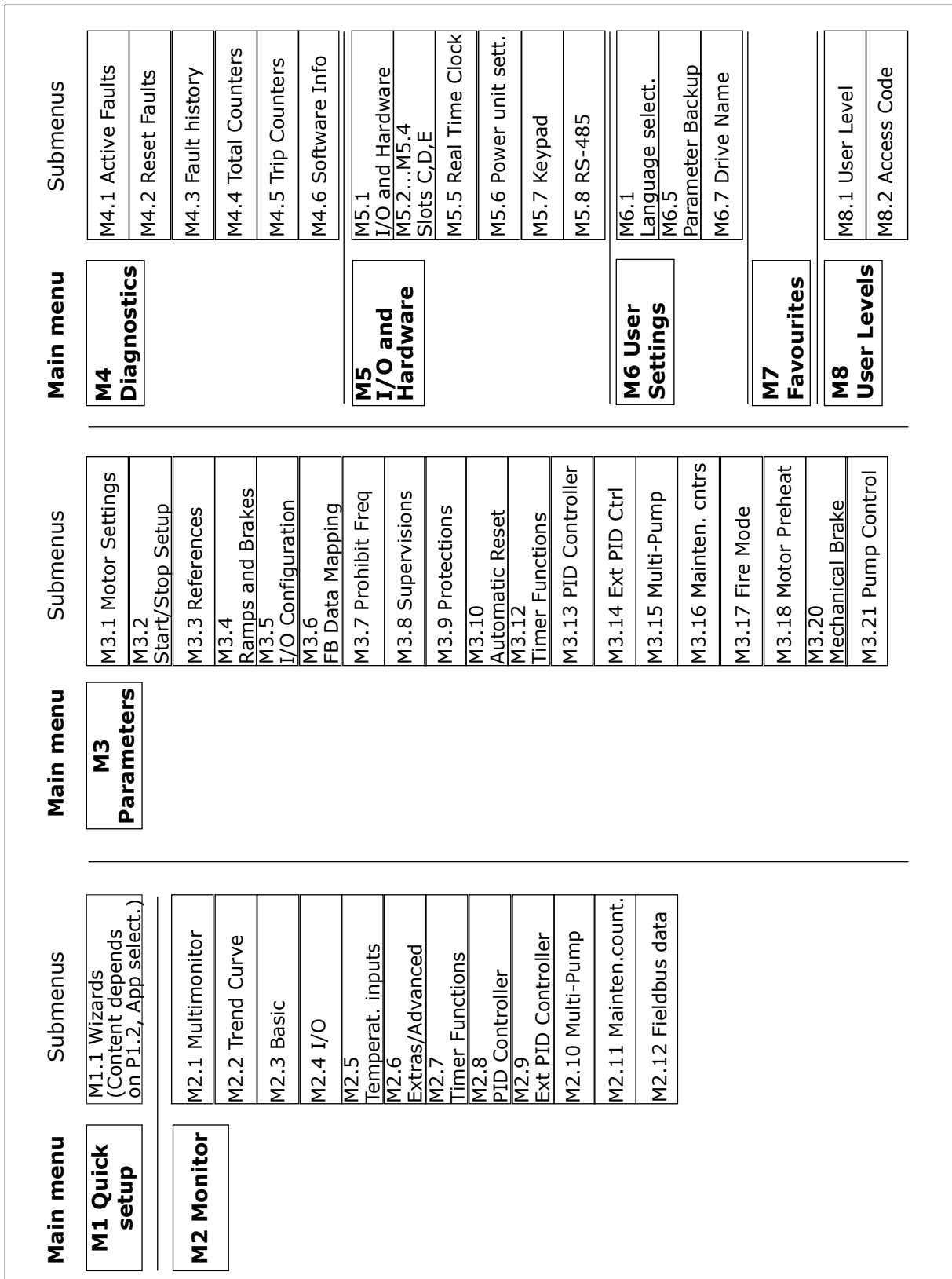

Fig. 16: The basic menu structure of the AC drive

### 3.2 USING THE GRAPHICAL DISPLAY

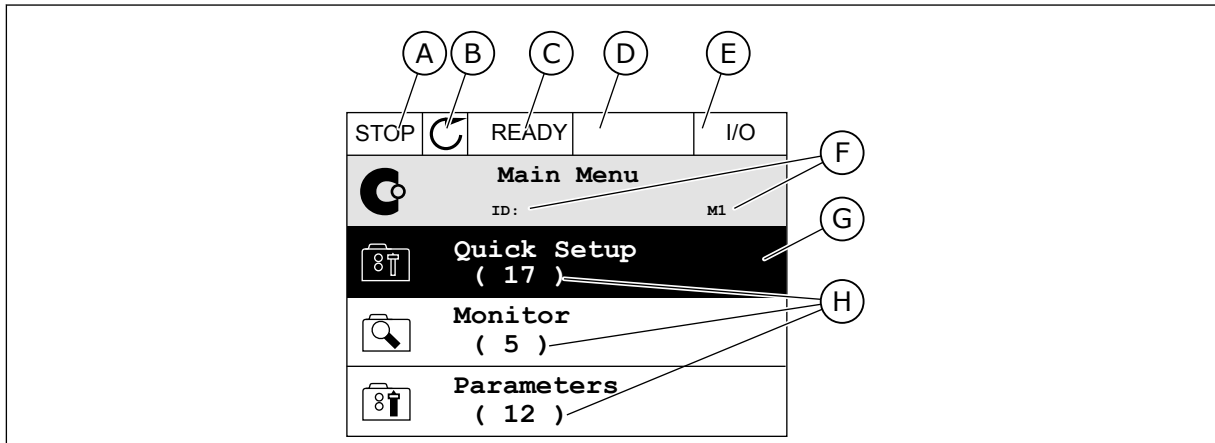

Fig. 17: The main menu of the graphical display

- A. The first status field: STOP/RUN
- B. The rotation direction
- C. The second status field: READY/NOT READY/FAULT
- D. The alarm field: ALARM/-
- E. The control place: PC/I/O/KEYPAD/ FIELDBUS
- F. The location field: the parameter ID number and the current location in the menu
- G. An activated group or item: push OK to go in
- H. The number of items in the group in question

#### 3.2.1 EDITING THE VALUES

On the graphical display, there are 2 different procedures to edit the value of an item.

Usually, you can set only 1 value for a parameter. Select from a list of text values or from a range of numerical values.

#### CHANGING THE TEXT VALUE OF A PARAMETER

- 1 Find the parameter with the arrow buttons.

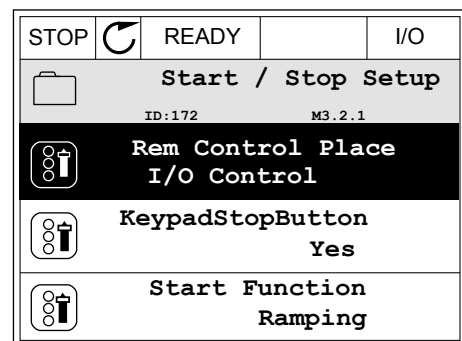

- To go to the Edit mode, push the OK button 2 times or push the arrow button Right.

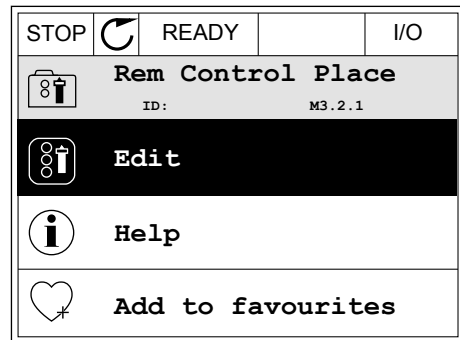

- To set a new value, push the arrow buttons Up and Down.

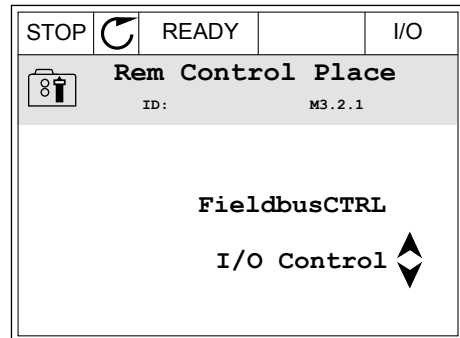

- To accept the change, push the OK button. To ignore the change, use the Back/Reset button.

**EDITING THE NUMERICAL VALUES**

- Find the parameter with the arrow buttons.

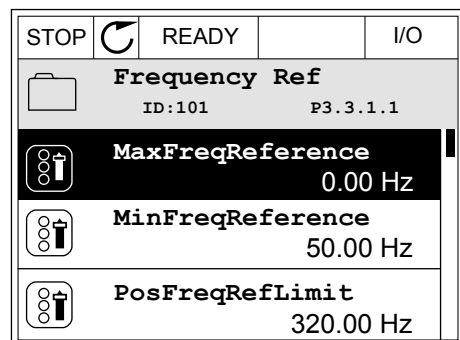

- Go to the Edit mode.

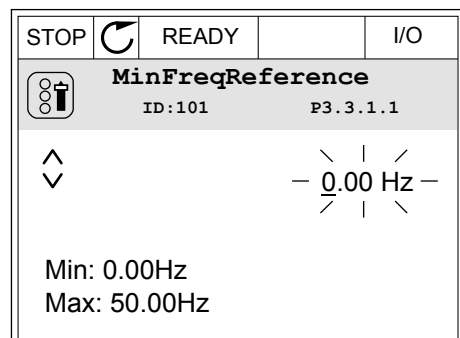

- 3 If the value is numerical, move from digit to digit with the arrow buttons Left and Right. Change the digits with the arrow buttons Up and Down.

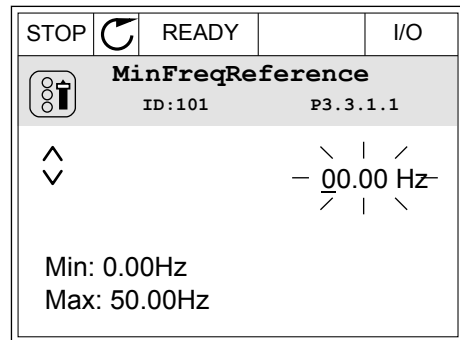

- 4 To accept the change, push the OK button. To ignore the change, go back to the level where you were before with the Back/Reset button.

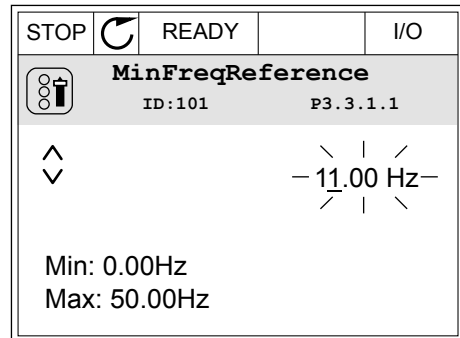

### THE SELECTION OF MORE THAN 1 VALUE

Some parameters let you to make a selection of more than 1 value. Select a checkbox at each necessary value.

- 1 Find the parameter. There is a symbol on the display when a checkbox selection is possible.

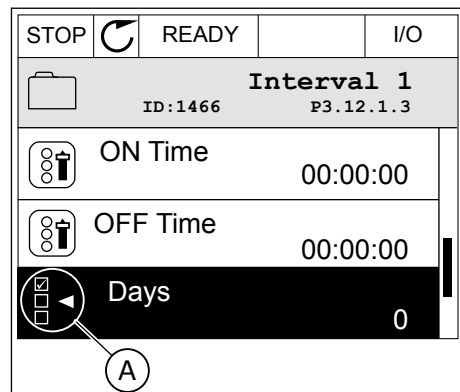

- A. The symbol of the checkbox selection

- To move in the list of values, use the arrow buttons Up and Down.

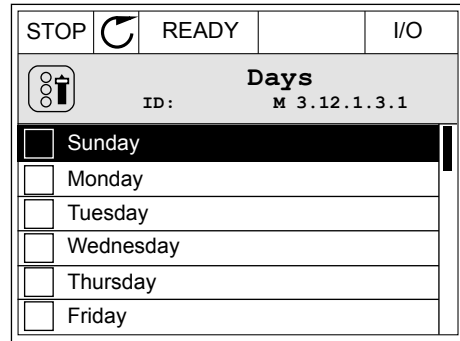

- To add a value into your selection, select the box that is next to it with the arrow button Right.

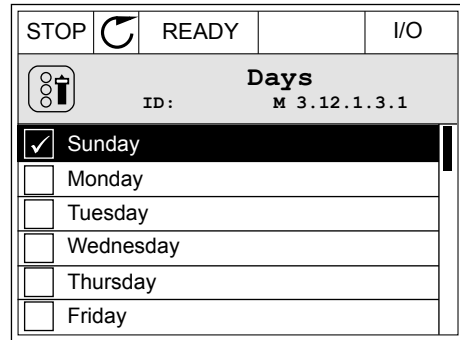

### 3.2.2 RESETTING A FAULT

To reset a fault, you can use the Reset button or the parameter Reset Faults. See the instructions in *11.1 A fault comes into view*.

### 3.2.3 THE FUNCT BUTTON

You can use the FUNCT button for 4 functions.

- To have an access to the Control page.
- To easily change between the Local and Remote control places.
- To change the rotation direction.
- To quickly edit a parameter value.

The selection of the control place determines from where the AC drive takes the start and stop commands. All the control places have a parameter for the selection of the frequency reference source. The Local control place is always the keypad. The Remote control place is I/O or Fieldbus. You can see the current control place on the status bar of the display.

It is possible to use I/O A, I/O B and Fieldbus as Remote control places. I/O A and Fieldbus have the lowest priority. You can make a selection of them with P3.2.1 (Remote Control Place). I/O B can bypass the Remote control places I/O A and Fieldbus with a digital input. You can make a selection of the digital input with parameter P3.5.1.7 (I/O B Control Force).

The keypad is always used as a control place when the control place is Local. Local control has higher priority than Remote control. For example, when you are in Remote control, if parameter P3.5.1.7 bypasses the control place with a digital input, and you make a selection of Local, Keypad becomes the control place. Use the FUNCT button or P3.2.2 Local/Remote to change between the Local and Remote control.

### CHANGING THE CONTROL PLACE

1 Anywhere in the menu structure, push the FUNCT button.

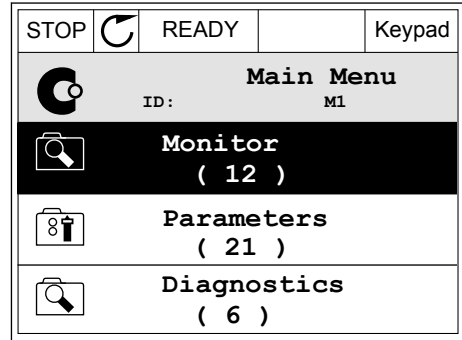

2 To make a selection of the Local/Remote, use the arrow buttons Up and Down. Push the OK button.

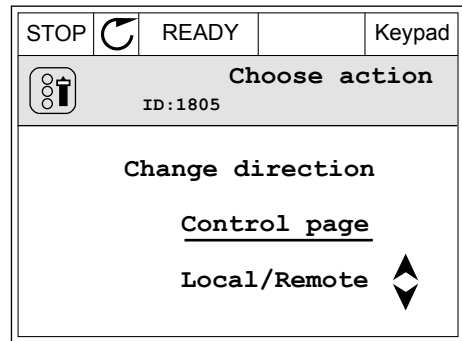

3 To make a selection of Local or Remote, use the arrow buttons Up and Down again. To accept the selection, push the OK button.

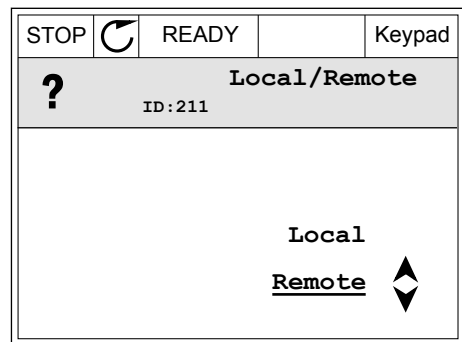

4 If you changed Remote control place to Local, that is, the keypad, give a keypad reference.

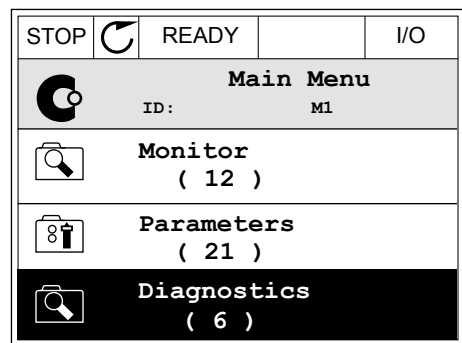

After the selection, the display goes back into the same location where it was when you pushed the FUNCT button.

### GOING INTO THE CONTROL PAGE

It is easy to monitor the most important values in the Control page.

- 1 Anywhere in the menu structure, push the FUNCT button.

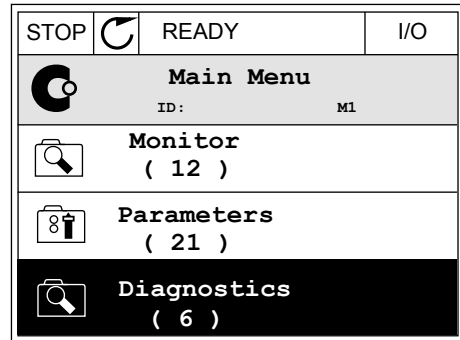

- 2 To make a selection of the Control page, push the arrow buttons Up and Down. Go in with the OK button. The control page opens.

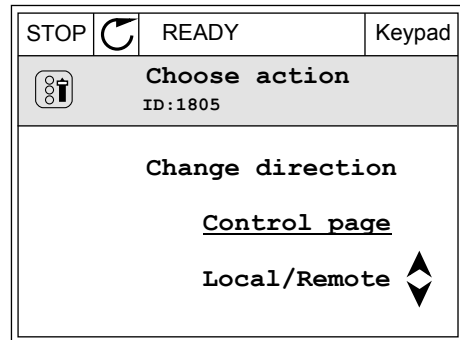

- 3 If you use the Local control place and the keypad reference, you can set P3.3.1.8 Keypad Reference with the OK button.

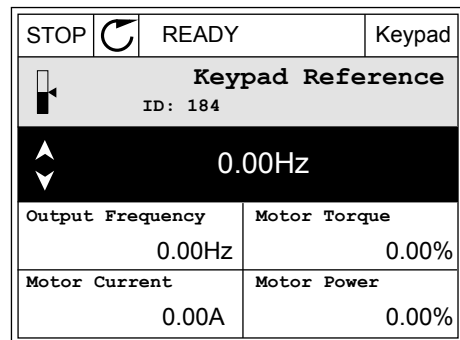

- 4 To change the digits in the value, push the arrow buttons Up and Down. Accept the change with the OK button.

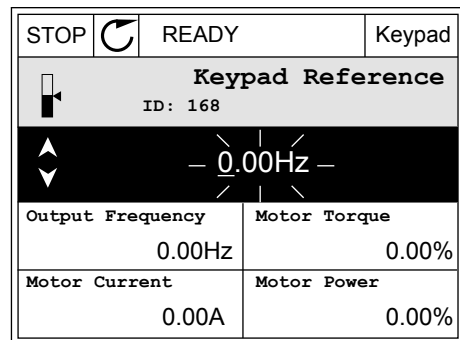

See more information about Keypad Reference in *5.3 Group 3.3: References*. If you use other control places or reference values, the display shows the frequency reference, which you

cannot edit. The other values on the page are Multimonitoring values. You can make a selection of the values that show up here (see instructions in 4.1.1 *Multimonitor*).

### CHANGING THE ROTATION DIRECTION

You can change the rotation direction of the motor quickly with the FUNCT button.



**NOTE!**

The command Change direction is available in the menu only if the current control place is Local.

- 1 Anywhere in the menu structure, push the FUNCT button.

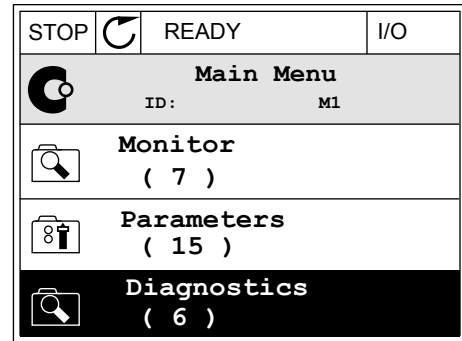

- 2 To make a selection of the Change direction, push the arrow buttons Up and Down. Push the OK button.

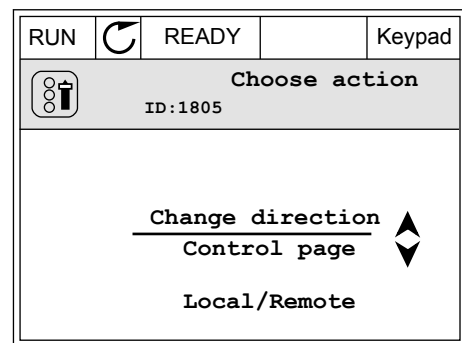

- 3 Make a selection of a new rotation direction. The current rotation direction blinks. Push the OK button.

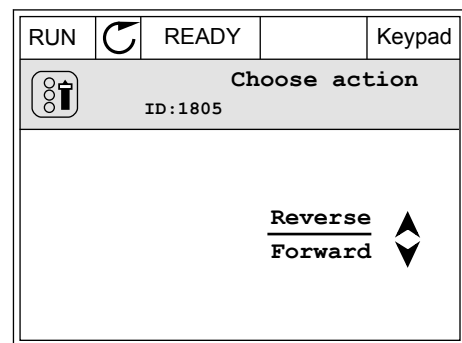



- 4 The rotation direction changes immediately. You can see that the arrow indication in the status field of the display changes.

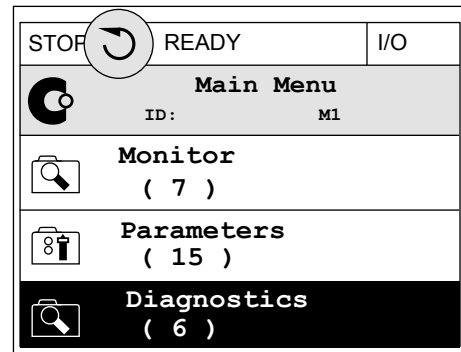

## THE QUICK EDIT FUNCTION

With the Quick edit function, you can have a quick access to a parameter by typing the ID number of the parameter.

- 1 Anywhere in the menu structure, push the FUNCT button.
- 2 Push the arrow buttons Up and Down to make a selection of Quick Edit and accept with the OK button.
- 3 Write the ID number of a parameter or monitoring value. Push OK. The display shows the parameter value in the edit mode and the monitoring value in the monitoring mode.

### 3.2.4 COPYING THE PARAMETERS



#### NOTE!

This function is available only in the graphical display.

Before you can copy parameters from the control panel to the drive, you must stop the drive.

#### COPYING THE PARAMETERS OF AN AC DRIVE

Use this function to copy parameters from a drive to another.

- 1 Save the parameters to the control panel.
- 2 Detach the control panel and connect it to another drive.
- 3 Download the parameters to the new drive with the command Restore from keypad.

**SAVING THE PARAMETERS TO THE CONTROL PANEL**

1 Go into the User settings menu.

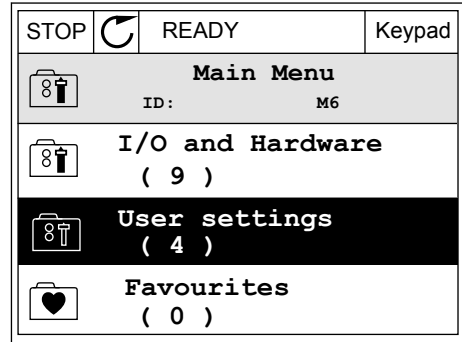

2 Go into the Parameter backup submenu.

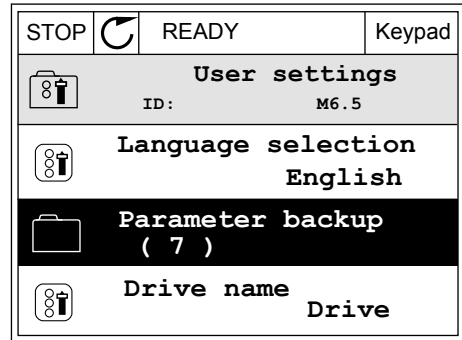

3 Use the arrow buttons Up and Down to make a selection of a function. Accept the selection with the OK button.

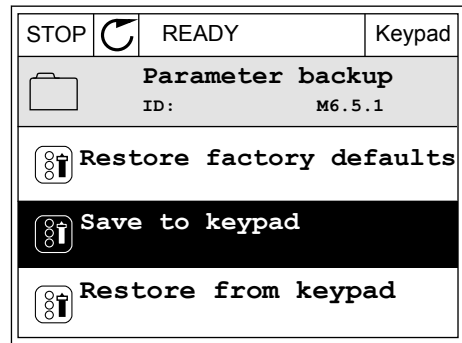

The command Restore factory defaults brings back the parameter settings that were made at the factory. With the command Save to keypad you can copy all the parameters to the control panel. The command Restore from keypad copies all the parameters from the control panel to the drive.

**The parameters that you cannot copy if the drives have a different size**

If you replace the control panel of a drive with a control panel from a drive that is of a different size, the values of these parameters do not change.

- Motor Nominal Voltage (P3.1.1.1)
- Motor Nominal Frequency (P3.1.1.2)
- Motor Nominal Speed (P3.1.1.3)
- Motor Nominal Current (P3.1.1.4)
- Motor Cos Phi (P3.1.1.5)
- Motor Nominal Power (P3.1.1.6)
- Switching Frequency (P3.1.2.3)
- Magnetising Current (P3.1.2.5)
- Stator Voltage Adjust (P3.1.2.13)
- Motor Current Limit (P3.1.3.1)
- Maximum Frequency Reference (P3.3.1.2)
- Field Weakening Point Frequency (P3.1.4.2)
- Voltage at Field Weakening Point (P3.1.4.3)
- U/f Midpoint Frequency (P3.1.4.4)
- U/f Midpoint Voltage (P3.1.4.5)
- Zero Frequency Voltage (P3.1.4.6)
- Start Magnetising Current (P3.4.3.1)
- DC Brake Current (P3.4.4.1)
- Flux Braking Current (P3.4.5.2)
- Motor Thermal Time Constant (P3.9.2.4)
- Stall Current Limit (P3.9.3.2)
- Motor Preheat Current (P3.18.3)

### 3.2.5 COMPARING THE PARAMETERS

With this function, you can compare the current parameter set with 1 of these 4 sets.

- Set 1 (P6.5.4 Save to Set 1)
- Set 2 (P6.5.6 Save to Set 2)
- The defaults (P6.5.1 Restore Factory Defaults)
- The keypad set (P6.5.2 Save to Keypad)

See more about these parameters in *Table 117 The parameter backup parameters in the user settings menu.*



#### NOTE!

If you have not saved the parameter set with which you want to compare the current set, the display shows the text *Comparing failed.*

### USING THE FUNCTION PARAMETER COMPARE

1 Go into Parameter Compare in the User settings menu.

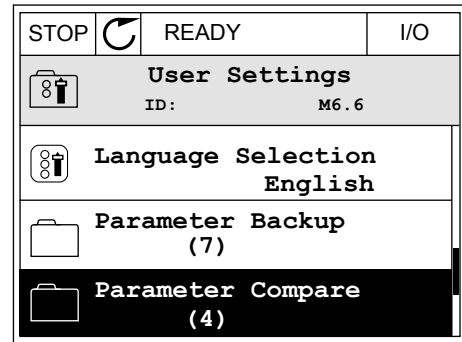

2 Make a selection of the pair of sets. Push OK to accept the selection.

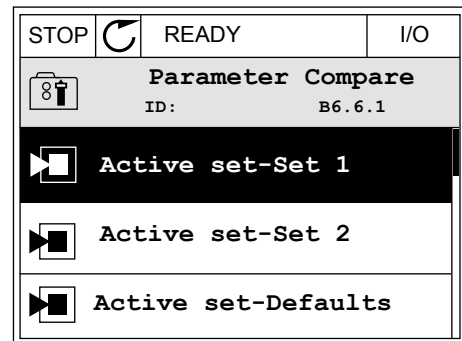

3 Make a selection of Active and push OK.

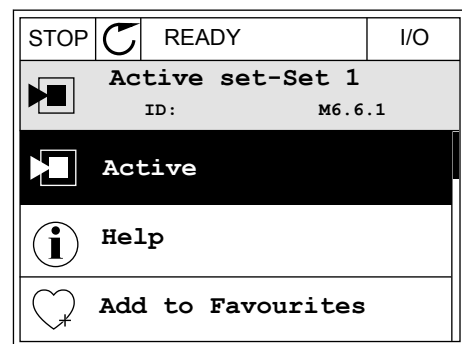

- Examine the comparing between the current values and the values of the other set.

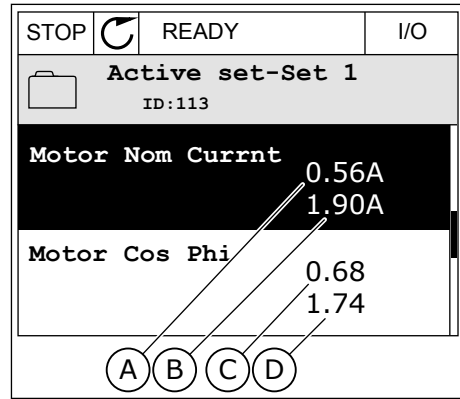

- The current value
- The value of the other set
- The current value
- The value of the other set

### 3.2.6 HELP TEXTS

The graphical display can show help texts on many topics. All the parameters have a help text.

The help texts are also available for the faults, alarms, and the Startup wizard.

#### READING A HELP TEXT

- Find the item about which you want to read.

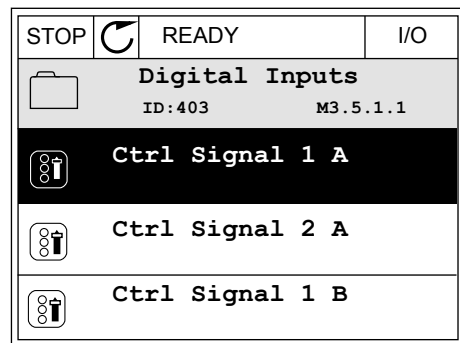

- Use the arrow buttons Up and Down to make a selection of Help.

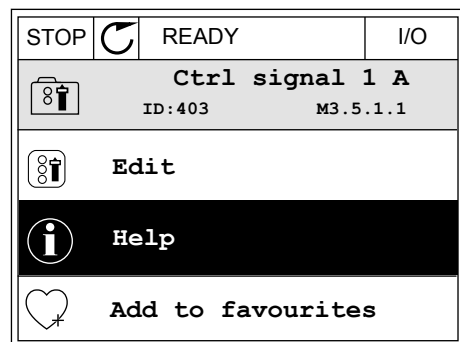

3 To open the help text, push the OK button.

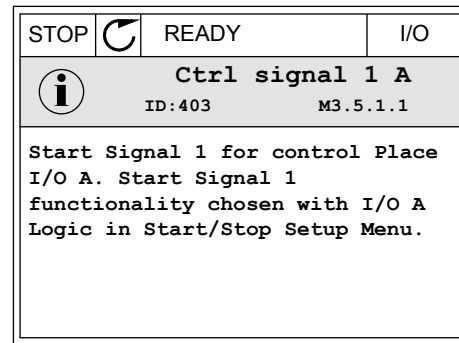

**NOTE!**

The help texts are always in English.

**3.2.7 USING THE FAVOURITES MENU**

If you use the same items frequently, you can add them into Favourites. You can collect a set of parameters or monitoring signals from all the keypad menus.

See more about how to use the Favourites menu in Chapter 8.2 *Favourites*.

**3.3 USING THE TEXT DISPLAY**

You can also have the control panel with the text display for your user interface. The text display and the graphical display have almost the same functions. Some functions are only available in the graphical display.

The display shows the status of the motor and the AC drive. It also shows faults in the operation of the motor and the drive. On the display, you see your current location in the menu. You also see the name of the group or item in your current location. If the text is too long for the display, the text scrolls to show the full text string.

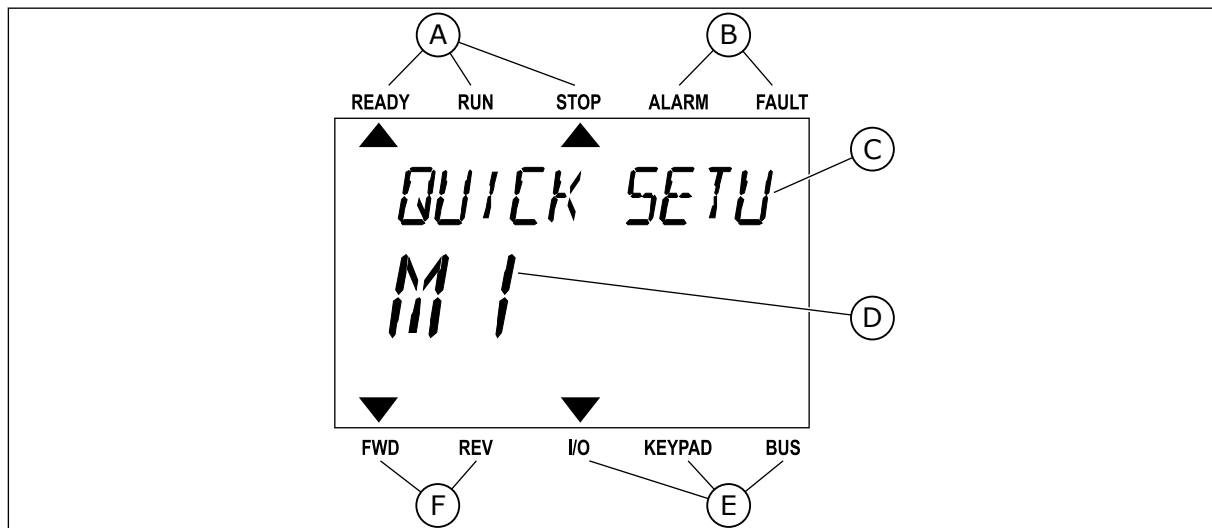

Fig. 18: The main menu of the text display

- A. The indicators of status
- B. The indicators of alarm and fault
- C. The name of the group or item of the current location

- D. The current location in the menu
- E. The indicators of the control place
- F. The indicators of the rotation direction

### 3.3.1 EDITING THE VALUES

#### CHANGING THE TEXT VALUE OF A PARAMETER

Set the value of a parameter with this procedure.

- 1 Find the parameter with the arrow buttons.



- 2 To go to the Edit mode, push the OK button.

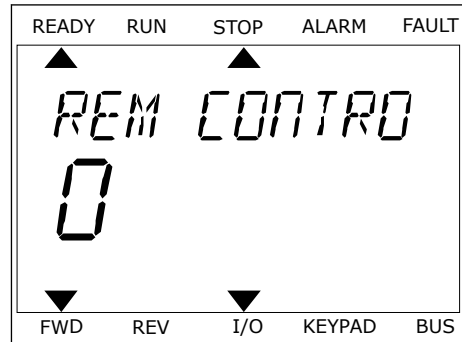

- 3 To set a new value, push the arrow buttons Up and Down.

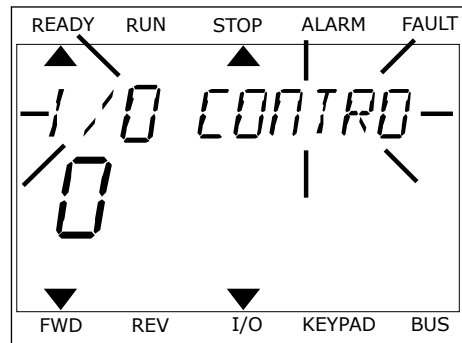

- 4 Accept the change with the OK button. To ignore the change, go back to the level where you were before with the Back/Reset button.

#### EDITING THE NUMERICAL VALUES

- 1 Find the parameter with the arrow buttons.
- 2 Go to the Edit mode.

- 3 Move from digit to digit with the arrow buttons Left and Right. Change the digits with the arrow buttons Up and Down.
- 4 Accept the change with the OK button. To ignore the change, go back to the level where you were before with the Back/Reset button.

### 3.3.2 RESETTING A FAULT

To reset a fault, you can use the Reset button or the parameter Reset Faults. See the instructions in *11.1 A fault comes into view*.

### 3.3.3 THE FUNCT BUTTON

You can use the FUNCT button for 4 functions.

- To have an access to the Control page.
- To easily change between the Local and Remote control places.
- To change the rotation direction.
- To quickly edit a parameter value.

The selection of the control place determines from where the AC drive takes the start and stop commands. All the control places have a parameter for the selection of the frequency reference source. The Local control place is always the keypad. The Remote control place is I/O or Fieldbus. You can see the current control place on the status bar of the display.

It is possible to use I/O A, I/O B and Fieldbus as Remote control places. I/O A and Fieldbus have the lowest priority. You can make a selection of them with P3.2.1 (Remote Control Place). I/O B can bypass the Remote control places I/O A and Fieldbus with a digital input. You can make a selection of the digital input with parameter P3.5.1.7 (I/O B Control Force).

The keypad is always used as a control place when the control place is Local. Local control has higher priority than Remote control. For example, when you are in Remote control, if parameter P3.5.1.7 bypasses the control place with a digital input, and you make a selection of Local, Keypad becomes the control place. Use the FUNCT button or P3.2.2 Local/Remote to change between the Local and Remote control.

### CHANGING THE CONTROL PLACE

- 1 Anywhere in the menu structure, push the FUNCT button.

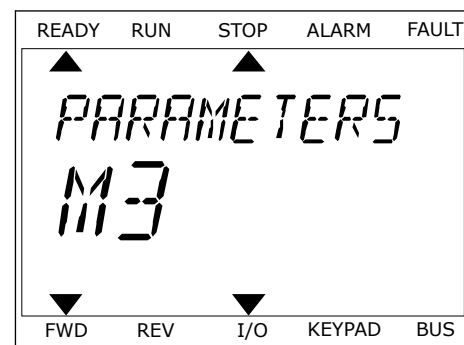



- 2 To make a selection of the Local/Remote, use the arrow buttons Up and Down. Push the OK button.



- 3 To make a selection of Local **or** Remote, use the arrow buttons Up and Down again. To accept the selection, push the OK button.

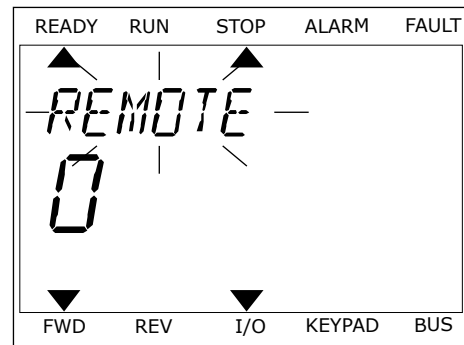

- 4 If you changed Remote control place to Local, that is, the keypad, give a keypad reference.

After the selection, the display goes back into the same location where it was when you pushed the FUNCT button.

### GOING INTO THE CONTROL PAGE

It is easy to monitor the most important values in the Control page.

- 1 Anywhere in the menu structure, push the FUNCT button.

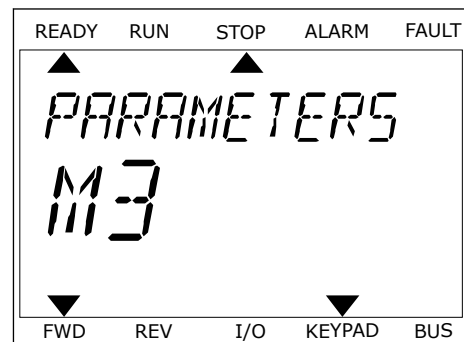

- To make a selection of the Control page, push the arrow buttons Up and Down. Go in with the OK button. The control page opens.

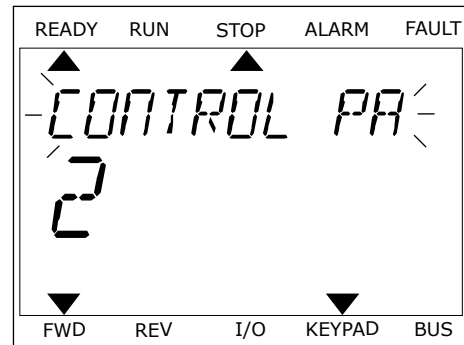

- If you use the Local control place and the keypad reference, you can set P3.3.1.8 Keypad Reference with the OK button.

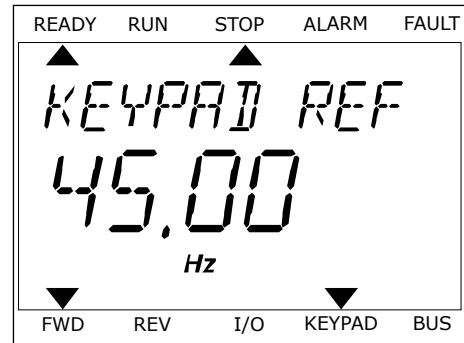

See more information about the Keypad Reference in 5.3 Group 3.3: References). If you use other control places or reference values, the display shows the frequency reference, which you cannot edit. The other values on the page are Multimonitoring values. You can make a selection of the values that show up here (see instructions in 4.1.1 Multimonitor).

### CHANGING THE ROTATION DIRECTION

You can change the rotation direction of the motor quickly with the FUNCT button.



#### NOTE!

The command Change direction is available in the menu only if the current control place is Local.

- Anywhere in the menu structure, push the FUNCT button.
- To make a selection of the Change direction, push the arrow buttons Up and Down. Push the OK button.
- Make a selection of a new rotation direction. The current rotation direction blinks. Push the OK button. The rotation direction changes immediately, and the arrow indication in the status field of the display changes.

### THE QUICK EDIT FUNCTION

With the Quick edit function, you can have a quick access to a parameter by typing the ID number of the parameter.

- 1 Anywhere in the menu structure, push the FUNCT button.
- 2 Push the arrow buttons Up and Down to make a selection of Quick Edit and accept with the OK button.
- 3 Write the ID number of a parameter or monitoring value. Push OK. The display shows the parameter value in the edit mode and the monitoring value in the monitoring mode.

### 3.4 MENU STRUCTURE

Menu	Function
<b>Quick setup</b>	See Chapter 1.4 <i>Description of the applications.</i>
<b>Monitor</b>	Multimonitor
	Trend curve
	Basic
	I/O
	Extras/Advanced
	Timer functions
	PID controller
	External PID controller
	Multi-pump
	Maintenance counters
	Fieldbus data
<b>Parameters</b>	See Chapter 5 <i>Parameters menu.</i>
<b>Diagnostics</b>	Active faults
	Reset faults
	Fault history
	Total counters
	Trip counters
	Software info

Menu	Function
<b>I/O and hardware</b>	Basic I/O
	Slot C
	Slot D
	Slot E
	Real time clock
	Power unit settings
	Keypad
	RS-485
	Ethernet
<b>User settings</b>	Language selections
	Parameter backup *
	Drive name
	Parameter compare
<b>Favourites *</b>	See Chapter 8.2 <i>Favourites</i> .
<b>User levels</b>	See Chapter 8.3 <i>User levels</i> .

\* = The function is not available in the control panel with a text display.

### 3.4.1 QUICK SETUP

The Quick Setup group includes the different wizards and quick setup parameters of the Vacon 100 Application. More detailed information on the parameters of this group you will find in chapter 1.3 *First start-up* and 2 *Wizards*.

### 3.4.2 MONITOR

#### MULTIMONITOR

With the Multimonitor function, you can collect 4 to 9 items to monitor. See 4.1.1 *Multimonitor*.

**NOTE!**

The Multimonitor menu is not available in the text display.

**TREND CURVE**

The Trend Curve function is a graphical presentation of 2 monitor values at the same time. See 4.1.2 *Trend curve*.

**BASIC**

The basic monitoring values can include statuses, measurements, and the actual values of parameters and signals. See 4.1.3 *Basic*.

**I/O**

It is possible to monitor the statuses and levels of the values of input and output signals. See 4.1.4 *I/O*.

**EXTRAS/ADVANCED**

You can monitor different advanced values, for example fieldbus values. See 4.1.6 *Extras and advanced*.

**TIMER FUNCTIONS**

With this function, you can monitor the timer functions and the Real Time Clock. See 4.1.7 *Timer functions monitoring*.

**PID CONTROLLER**

With this function, you can monitor the PID controller values. See 4.1.8 *PID controller monitoring*.

**EXTERNAL PID CONTROLLER**

Monitor the values that are related to the external PID controller. See 4.1.9 *External PID controller monitoring*.

**MULTI-PUMP**

Use this function to monitor the values that are related to the operation of more than 1 drive. See 4.1.10 *Multi-pump monitoring*.

**MAINTENANCE COUNTERS**

Monitor the values related to the maintenance counters. See 4.1.11 *Maintenance counters*.

**FIELDBUS DATA**

With this function, you see the fieldbus data as monitor values. Use this function, for example, for monitoring during the fieldbus commissioning. See 4.1.12 *Fieldbus process data monitoring*.

### 3.5 VACON LIVE

Vacon Live is a PC tool for commissioning and maintenance of the Vacon® 10, Vacon® 20, and Vacon® 100 AC drives). You can download Vacon Live from [www.vacon.com](http://www.vacon.com).

The Vacon Live PC tool includes these functions.

- Parametrisation, monitoring, drive info, data logger, etc.
- The software download tool Vacon Loader
- Serial communication and Ethernet support
- Windows XP, Vista 7 and 8 support
- 17 languages: English, German, Spanish, Finnish, French, Italian, Russian, Swedish, Chinese, Czech, Danish, Dutch, Polish, Portuguese, Romanian, Slovak and Turkish

You can make the connection between the AC drive and the PC tool with the Vacon serial communication cable. The serial communication drivers are installed automatically during the installation of Vacon Live. After you installed the cable, Vacon Live finds the connected drive automatically.

See more on how to use Vacon Live in the help menu of the program.

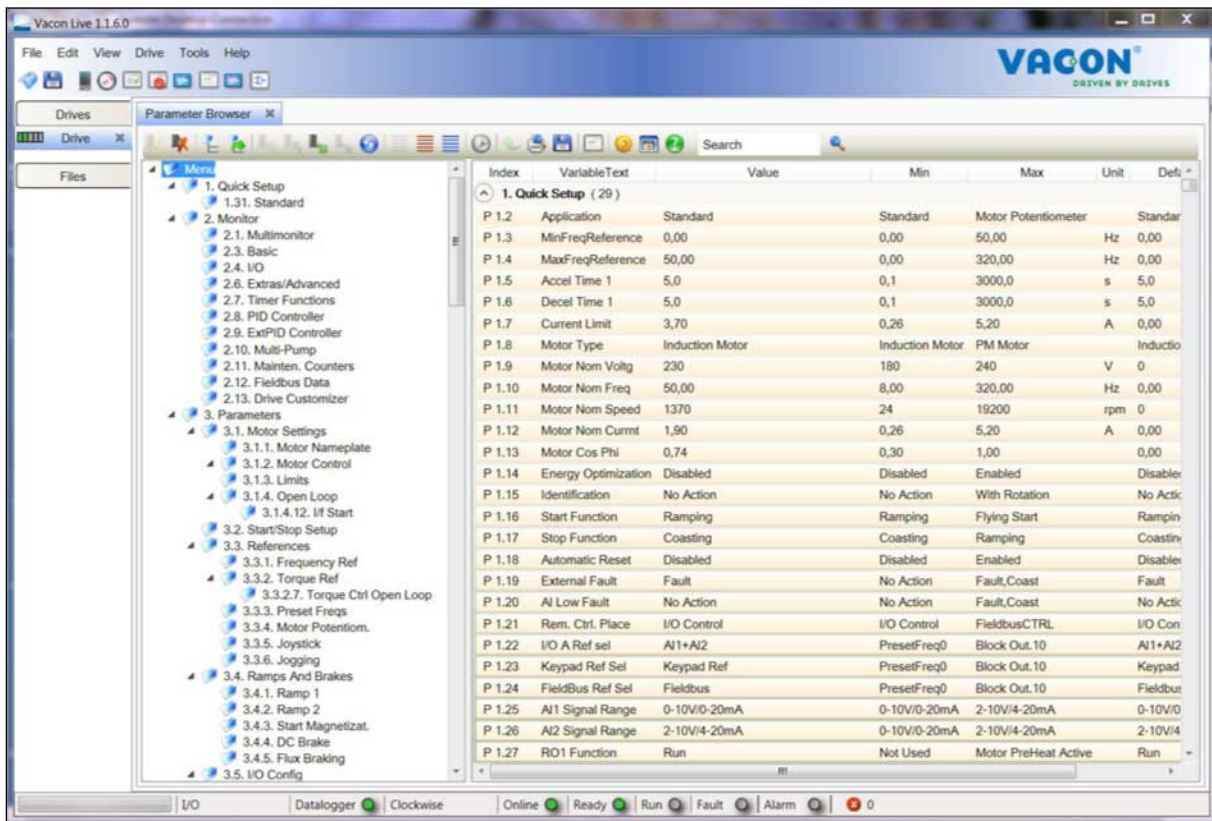

Fig. 19: The Vacon Live PC tool

# 4 MONITORING MENU

## 4.1 MONITOR GROUP

You can monitor the actual values of the parameters and signals. You can also monitor the statuses and measurements. You can customise some of the values that you can monitor.

### 4.1.1 MULTIMONITOR

On the Multimonitor page, you can collect 4 to 9 items to monitor. Make a selection of the number of items with the parameter 3.11.4 Multimonitor View. See more in chapter 5.11 *Group 3.11: Application settings*.

### CHANGING THE ITEMS TO MONITOR

1 Go into the Monitor menu with the OK button.

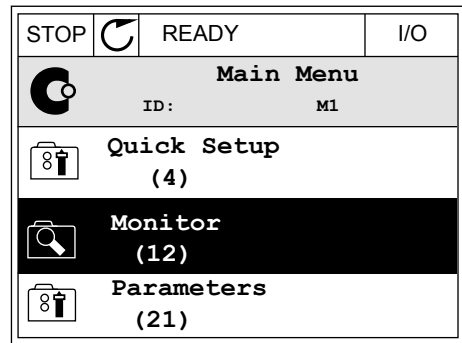

2 Go into Multimonitor.

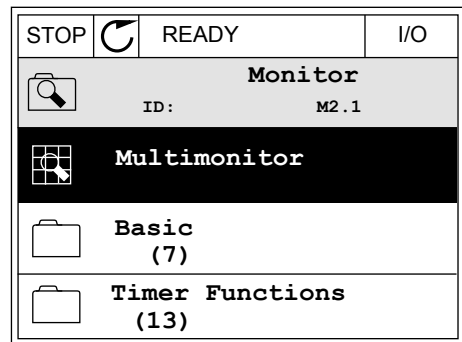

3 To replace an old item, activate it. Use the arrow buttons.

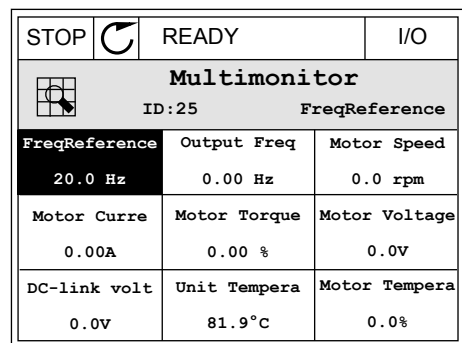



- To make a selection of a new item in the list, push OK.

STOP		READY	I/O
<b>FreqReference</b>			
ID:1		M2.1.1.1	
<input checked="" type="checkbox"/>	Output frequency	0.00 Hz	
<input checked="" type="checkbox"/>	FreqReference	10.00 Hz	
<input checked="" type="checkbox"/>	Motor Speed	0.00 rpm	
<input checked="" type="checkbox"/>	Motor Current	0.00 A	
<input checked="" type="checkbox"/>	Motor Torque	0.00 %	
<input type="checkbox"/>	Motor Power	0.00 %	

### 4.1.2 TREND CURVE

The Trend curve is a graphical presentation of 2 monitor values.

When you make a selection of a value, the drive starts to record the values. In the Trend curve submenu, you can examine the trend curve, make the signal selections. You can also give the minimum and maximum settings and the sampling interval, and use Autoscaling.

### CHANGING THE VALUES

Change the monitoring values with this procedure.

- In the Monitor menu, find the Trend curve submenu and push OK.

STOP		READY	I/O
<b>Monitor</b>			
ID:		M2.2	
	Multimonitor		
	<b>Trend Curve</b> (7)		
	Basic (13)		

- Go into the submenu View trend curve with the OK button.

STOP		READY	I/O
<b>Trend Curve</b>			
ID:		M2.2.1	
	<b>View Trend Curve</b> (2)		
	Sampling interval	100 ms	
	Channel 1 min	-1000	

- 3 You can monitor only 2 values as trend curves at the same time. The current selections, FreqReference and Motor speed, are at the bottom of the display. To make a selection of the current value that you wish to change, use the arrow buttons up and down. Push OK.

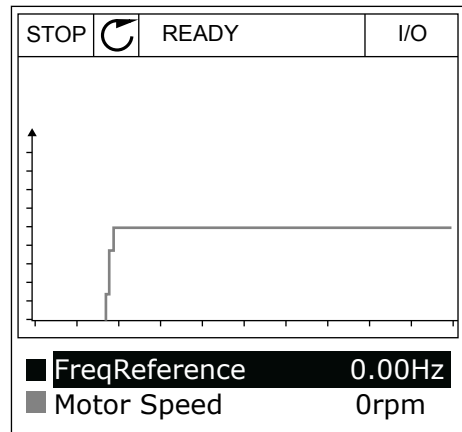

- 4 Go through the list of the monitoring values with the arrow buttons.

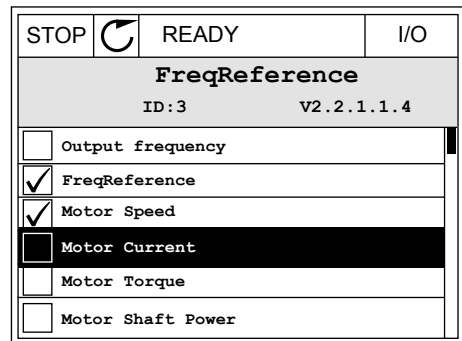

- 5 Make a selection and push OK.

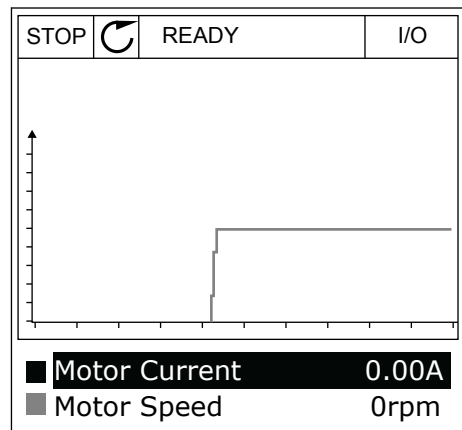

### STOPPING THE PROGRESSION OF THE CURVE

The Trend curve function also lets you to stop the curve and read the current values. After, you can start the progression of the curve again.

- 1 In Trend curve view, make a curve active with the arrow button Up. The frame of the display turns bold.

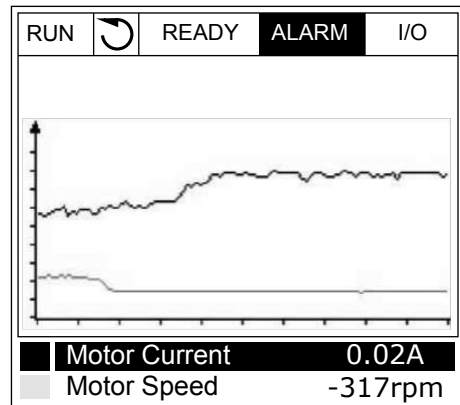

- 2 Push OK at the target point of the curve.

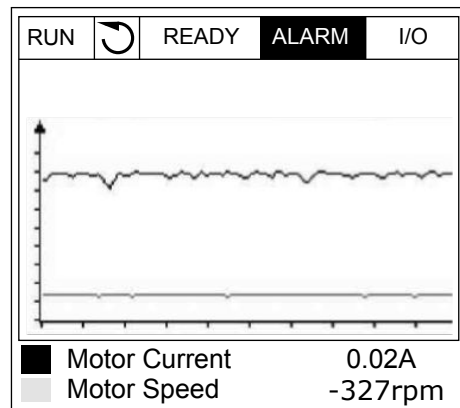

- 3 A vertical line comes into view on the display. The values at the bottom of the display agree to the location of the line.

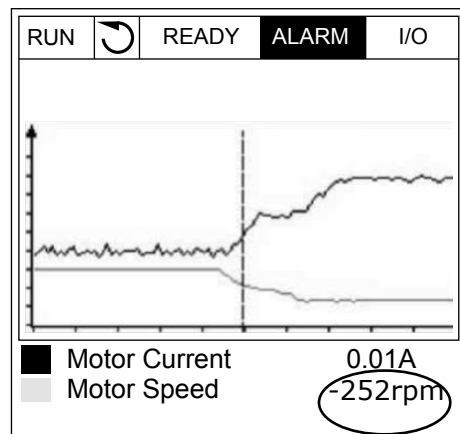

- 4 To move the line to see the values of some other location, use the arrow buttons Left and Right.

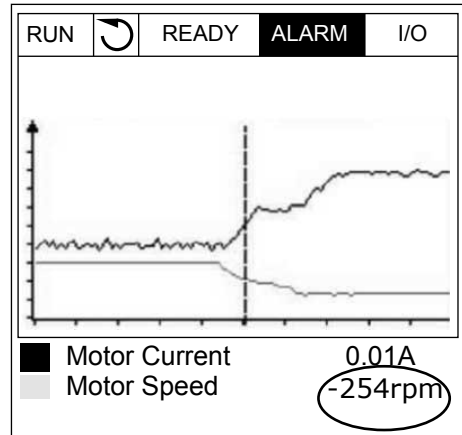

**Table 20: The trend curve parameters**

Index	Parameter	Min	Max	Unit	Default	ID	Description
M2.2.1	View Trend curve						Go into this menu to monitor values in a curve form.
P2.2.2	Sampling interval	100	432000	ms	100	2368	
P2.2.3	Channel 1 min	-214748	1000		-1000	2369	
P2.2.4	Channel 1 max	-1000	214748		1000	2370	
P2.2.5	Channel 2 min	-214748	1000		-1000	2371	
P2.2.6	Channel 2 max	-1000	214748		1000	2372	
P2.2.7	Autoscale	0	1		0	2373	0 = Disabled 1 = Enabled

### 4.1.3 BASIC

You can see the basic monitoring values and their related data in the next table.



**NOTE!**

Only the standard I/O board statuses are available in the Monitor menu. You can find the statuses of all the I/O board signals as raw data in the I/O and Hardware menu.

Do a check of the statuses of the expander I/O board in the I/O and Hardware menu when the system asks you to do it.

**Table 21: Items in the monitoring menu**

Index	Monitoring value	Unit	Scale	ID	Description
V2.3.1	Output frequency	Hz	0.01	1	
V2.3.2	Frequency reference	Hz	0.01	25	
V2.3.3	Motor speed	rpm	1	2	
V2.3.4	Motor current	A	Varies	3	
V2.3.5	Motor torque	%	0.1	4	
V2.3.7	Motor shaft power	%	0.1	5	
V2.3.8	Motor shaft power	kW/hp	Varies	73	
V2.3.9	Motor voltage	V	0.1	6	
V2.3.10	DC link voltage	V	1	7	
V2.3.11	Unit temperature	°C	0.1	8	
V2.3.12	Motor temperature	%	0.1	9	
V2.3.13	Motor Preheat		1	1228	0 = OFF 1 = Heating (feeding DC-current)
V2.3.14	Torque reference	%	0.1	18	

## 4.1.4 I/O

**Table 22: I/O signal monitoring**

Index	Monitoring value	Unit	Scale	ID	Description
V2.4.1	Slot A DIN 1, 2, 3		1	15	
V2.4.2	Slot A DIN 4, 5, 6		1	16	
V2.4.3	Slot B RO 1, 2, 3		1	17	
V2.4.4	Analogue input 1	%	0.01	59	Slot A.1 as default.
V2.4.5	Analogue input 2	%	0.01	60	Slot A.2 as default.
V2.4.6	Analogue input 3	%	0.01	61	Slot D.1 as default.
V2.4.7	Analogue input 4	%	0.01	62	Slot D.2 as default.
V2.4.8	Analogue input 5	%	0.01	75	Slot E.1 as default.
V2.4.9	Analogue input 6	%	0.01	76	Slot E.2 as default.
V2.4.10	Slot A AO1	%	0.01	81	

## 4.1.5 TEMPERATURE INPUTS

**NOTE!**

This parameter group is visible when you have an option board for temperature measurement (OPT-BH).

**Table 23: Monitoring the temperature inputs**

Index	Monitoring value	Unit	Scale	ID	Description
V2.5.1	Temperature input 1	°C	0.1	50	
V2.5.2	Temperature input 2	°C	0.1	51	
V2.5.3	Temperature input 3	°C	0.1	52	
V2.5.4	Temperature input 4	°C	0.1	69	
V2.5.5	Temperature input 5	°C	0.1	70	
V2.5.6	Temperature input 6	°C	0.1	71	

## 4.1.6 EXTRAS AND ADVANCED

**Table 24: Monitoring of the advanced values**

Index	Monitoring value	Unit	Scale	ID	Description
V2.6.1	Drive Status Word		1	43	B1 = Ready B2 = Run B3 = Fault B6 = RunEnable B7 = AlarmActive B10 = DC current in stop B11 = DC brake active B12 = RunRequest B13 = MotorRegulatorActive
V2.6.2	Ready status		1	78	B0 = RunEnable high B1 = No fault active B2 = Charge switch closed B3 = DC voltage within limits B4 = Power manager initialised B5 = Power unit is not blocking start B6 = System software is not blocking start
V2.6.3	Application Status Word1		1	89	B0 = Interlock 1 B1 = Interlock 2 B2 = Reserved B3 = Ramp 2 active B4 = Mechanical brake control B5 = I/O A control active B6 = I/O B control active B7 = Fieldbus Control Active B8 = Local control active B9 = PC control active B10 = Preset frequencies active B11 = Jogging active B12 = Fire Mode active B13 = Motor Preheat active B14 = Quick stop active B15 = Drive stopped from keypad
V2.6.4	Application Status Word2		1	90	B0 = Acc/Dec prohibited B1 = Motor switch open B5 = Jockey pump active B6 = Priming pump active B7 = Input pressure supervision (Alarm/Fault) B8 = Frost protection (Alarm/Fault) B9 = Autocleaning active
V2.6.5	DIN Status Word 1		1	56	
V2.6.6	DIN Status Word 2		1	57	

**Table 24: Monitoring of the advanced values**

Index	Monitoring value	Unit	Scale	ID	Description
V2.6.7	Motor current 1 decimal		0.1	45	
V2.6.8	Frequency reference source		1	1495	0 = PC 1 = Preset Freqs 2 = Keypad Reference 3 = Fieldbus 4 = AI1 5 = AI2 6 = AI1+AI2 7 = PID Controller 8 = Motor Potentiom. 9 = Joystick 10 = Jogging 100 = Not defined 101 = Alarm, PresetFreq 102 = Auto-cleaning
V2.6.9	Last active fault code		1	37	
V2.6.10	Last active fault ID		1	95	
V2.6.11	Last active alarm code		1	74	
V2.6.12	Last active alarm ID		1	94	
V2.6.13	Motor regulator status		1	77	B0 = Current Limit (Motor) B1 = Current Limit (Generator) B2 = Torque Limit (Motor) B3 = Torque Limit (Generator) B4 = Overvoltage Control B5 = Undervoltage Control B6 = Power Limit (Motor) B7 = Power Limit (Generator)

#### 4.1.7 TIMER FUNCTIONS MONITORING

Monitor the values of Timer functions and the Real Time Clock.



**Table 25: Monitoring of the timer functions**

Index	Monitoring value	Unit	Scale	ID	Description
V2.7.1	TC 1, TC 2, TC 3		1	1441	
V2.7.2	Interval 1		1	1442	
V2.7.3	Interval 2		1	1443	
V2.7.4	Interval 3		1	1444	
V2.7.5	Interval 4		1	1445	
V2.7.6	Interval 5		1	1446	
V2.7.7	Timer 1	s	1	1447	
V2.7.8	Timer 2	s	1	1448	
V2.7.9	Timer 3	s	1	1449	
V2.7.10	Real time clock			1450	

#### 4.1.8 PID CONTROLLER MONITORING

**Table 26: Monitoring of the values of the PID controller**

Index	Monitoring value	Unit	Scale	ID	Description
V2.8.1	PID1 setpoint	Varies	As is set in P3.13.1.7 (See 5.13 Group 3.13: PID controller)	20	
V2.8.2	PID1 feedback	Varies	As is set in P3.13.1.7	21	
V2.8.3	PID1 error value	Varies	As is set in P3.13.1.7	22	
V2.8.4	PID1 output	%	0.01	23	
V2.8.5	PID1 status		1	24	0 = Stopped 1 = Running 3 = Sleep mode 4 = In dead band (see 5.13 Group 3.13: PID controller)

#### 4.1.9 EXTERNAL PID CONTROLLER MONITORING

**Table 27: Monitoring of the values of the external PID controller**

Index	Monitoring value	Unit	Scale	ID	Description
V2.9.1	ExtPID Setpoint	Varies	As set in P3.14.1.1 0 (See 5.14 Group 3.14: External PID controller)	83	
V2.9.2	ExtPID Feedback	Varies	As set in P3.14.1.1 0	84	
V2.9.3	ExtPID Error	Varies	As set in P3.14.1.1 0	85	
V2.9.4	ExtPID Output	%	0.01	86	
V2.9.5	ExtPID Status		1	87	0=Stopped 1=Running 2=In dead band (see 5.14 Group 3.14: External PID controller)

#### 4.1.10 MULTI-PUMP MONITORING

**Table 28: Multi-pump monitoring**

Index	Monitoring value	Unit	Scale	ID	Description
V2.10.1	Motors running		1	30	
V2.10.2	Autochange		1	1114	

#### 4.1.11 MAINTENANCE COUNTERS

**Table 29: Maintenance counter monitoring**

Index	Monitoring value	Unit	Scale	ID	Description
V2.11.1	Maintenance counter 1	h/ kRev	Varies	1101	

## 4.1.12 FIELDBUS PROCESS DATA MONITORING

**Table 30: Fieldbus process data monitoring**

Index	Monitoring value	Unit	Scale	ID	Description
V2.12.1	FB Control Word		1	874	
V2.12.2	FB Speed Reference		Varies	875	
V2.12.3	FB data in 1		1	876	
V2.12.4	FB data in 2		1	877	
V2.12.5	FB data in 3		1	878	
V2.12.6	FB data in 4		1	879	
V2.12.7	FB data in 5		1	880	
V2.12.8	FB data in 6		1	881	
V2.12.9	FB data in 7		1	882	
V2.12.10	FB data in 8		1	883	
V2.12.11	FB Status Word		1	864	
V2.12.12	FB Speed Actual		0.01	865	
V2.12.13	FB data out 1		1	866	
V2.12.14	FB data out 2		1	867	
V2.12.15	FB data out 3		1	868	
V2.12.16	FB data out 4		1	869	
V2.12.17	FB data out 5		1	870	
V2.12.18	FB data out 6		1	871	
V2.12.19	FB data out 7		1	872	
V2.12.20	FB data out 8		1	873	

## 5 PARAMETERS MENU

### 5.1 GROUP 3.1: MOTOR SETTINGS

**Table 31: Motor nameplate parameters**

Index	Parameter	Min	Max	Unit	Default	ID	Description
P3.1.1.1	Motor Nominal Voltage	Varies	Varies	V	Varies	110	
P3.1.1.2	Motor Nominal Frequency	8.00	320.00	Hz	50 / 60	111	
P3.1.1.3	Motor Nominal Speed	24	19200	rpm	Varies	112	
P3.1.1.4	Motor Nominal Current	I <sub>H</sub> * 0.1	I <sub>H</sub> * 2	A	Varies	113	
P3.1.1.5	Motor Cos Phi (Power Factor)	0.30	1.00		Varies	120	
P3.1.1.6	Motor Nominal Power	Varies	Varies	kW	Varies	116	

**Table 32: Motor control settings**

Index	Parameter	Min	Max	Unit	Default	ID	Description
P3.1.2.1	Control Mode	0	2		0	600	0 = Frequency control (open loop) 1 = Speed control (open loop) 2 = Torque control (open loop)
P3.1.2.2	Motor Type	0	2		0	650	0 = Induction motor 1 = PM motor 2 = Reluctance motor
P3.1.2.3	Switching Frequency	1.5	Varies	kHz	Varies	601	
P3.1.2.4	Identification	0	2		0	631	0 = No action 1 = At standstill 2 = With rotation
P3.1.2.5	Magnetizing Current	0.0	2*I <sub>H</sub>	A	0.0	612	
P3.1.2.6	Motor Switch	0	1		0	653	0 = Disabled 1 = Enabled
P3.1.2.7	Load Drooping	0.00	20.00	%	0.00	620	
P3.1.2.8	Load Drooping Time	0.00	2.00	s	0.00	656	
P3.1.2.9	Load Drooping Mode	0	1		0	1534	0 = Normal. 1 = Linear removal.
P3.1.2.10	Overvoltage Control	0	1		1	607	0 = Disabled 1 = Enabled
P3.1.2.11	Undervoltage Control	0	1		1	608	0 = Disabled 1 = Enabled
P3.1.2.12	Energy Optimization	0	1		0	666	0 = Disabled 1 = Enabled
P3.1.2.13	Stator Voltage Adjust	50.0	150.0	%	100.0	659	

**Table 32: Motor control settings**

Index	Parameter	Min	Max	Unit	Default	ID	Description
P3.1.2.14	Overmodulation	0	1		1	1515	0 = Disabled 1 = Enabled

**Table 33: Motor limit settings**

Index	Parameter	Min	Max	Unit	Default	ID	Description
P3.1.3.1	Motor Current Limit	$I_H \cdot 0.1$	$I_S$	A	Varies	107	
P3.1.3.2	Motor Torque Limit	0.0	300.0	%	300.0	1287	
P3.1.3.3	Generator Torque Limit	0.0	300.0	%	300.0	1288	
P3.1.3.4	Motor Power Limit	0.0	300.0	%	300.0	1289	
P3.1.3.5	Generator Power Limit	0.0	300.0	%	300.0	1290	

**Table 34: Open loop settings**

Index	Parameter	Min	Max	Unit	Default	ID	Description
P3.1.4.1	U/f Ratio	0	2		0	108	0=Linear 1=Squared 2=Programmable
P3.1.4.2	Field Weakening Point Frequency	8.00	P3.3.1.2	Hz	Varies	602	
P3.1.4.3	Voltage at Field Weakening Point	10.00	200.00	%	100.00	603	
P3.1.4.4	U/f Midpoint Frequency	0.00	P3.1.4.2.	Hz	Varies	604	
P3.1.4.5	U/f Midpoint Voltage	0.0	100.0	%	100.0	605	
P3.1.4.6	Zero Frequency Voltage	0.00	40.00	%	Varies	606	
P3.1.4.7	Flying Start Options	0	127		0	1590	B0 = Search the shaft frequency only from the same direction as the frequency reference B1 = Disable AC scanning B4 = Use the frequency reference for the initial guess B5 = Disable DC pulses B6 = Flux build with current control
P3.1.4.8	Flying Start Scan Current	0.0	100.0	%	45.0	1610	
P3.1.4.9	Auto Torque Boost	0	1		0	109	0=Disabled 1=Enabled
P3.1.4.10	Torque Boost Motor Gain	0.0	100.0	%	100.0	667	
P3.1.4.11	Torque Boost Generator Gain	0.0	100.0	%	0.0	665	
M3.1.4.12	I/f Start	This menu includes 3 parameters. See the table below.					

**Table 35: I/f start parameters**

Index	Parameter	Min	Max	Unit	Default	ID	Description
P3.1.4.12.1	I/f Start	0	1		0	534	0 = Disabled 1 = Enabled
P3.1.4.12.2	I/f Start Frequency	5.0	0.5 * P3.1.1.2		0.2 * P3.1.1.2	535	
P3.1.4.12.3	I/f Start Current	0.0	100.0	%	80.0	536	

**Table 36: Torque stabilator parameters**

Index	Parameter	Min	Max	Unit	Default	ID	Description
P3.1.4.13.1	Torque Stabilator Gain	0.0	500.0	%	50.0	1412	
P3.1.4.13.2	Torque Stabilator Gain at Field Weakening Point	0.0	500.0	%	50.0	1414	
P3.1.4.13.3	Torque Stabilator Damping Time Constant	0.0005	1.0000	s	0.0050	1413	
P3.1.4.13.4	Torque Stabilator Damping Time Constant (for PM motors)	0.0005	1.0000	s	0.0050	1735	

**Table 37: Sensorless control settings**

Index	Parameter	Min	Max	Unit	Default	ID	Description
P3.1.6.1	Sensorless Control	0	1		0	1724	0=Disabled 1=Enabled



## 5.2 GROUP 3.2: START/STOP SETUP

**Table 38: Start/stop setup menu**

Index	Parameter	Min	Max	Unit	Default	ID	Description
P3.2.1	Remote Control Place	0	1		0 *	172	0 = I/O control 1 = Fieldbus control
P3.2.2	Local/Remote	0	1		0 *	211	0 = Remote 1 = Local
P3.2.3	Keypad Stop Button	0	1		0	114	0 = Yes 1 = No
P3.2.4	Start Function	0	1		0	505	0 = Ramping 1 = Flying start
P3.2.5	Stop Function	0	1		0	506	0 = Coasting 1 = Ramping

**Table 38: Start/stop setup menu**

Index	Parameter	Min	Max	Unit	Default	ID	Description
P3.2.6	I/O A Start/Stop Logic	0	4		2 *	300	<p><b>Logic = 0</b> Ctrl sgn 1 = Forward Ctrl sgn 2 = Backward</p> <p><b>Logic = 1</b> Ctrl sgn 1 = Forward (edge) Ctrl sgn 2 = Inverted Stop Ctrl sgn 3 = Bckwrđ (edge)</p> <p><b>Logic = 2</b> Ctrl sgn 1 = Forward (edge) Ctrl sgn 2 = Bckwrđ (edge)</p> <p><b>Logic = 3</b> Ctrl sgn 1 = Start Ctrl sgn 2 = Reverse</p> <p><b>Logic = 4</b> Ctrl sgn 1 = Start (edge) Ctrl sgn 2 = Reverse</p>
P3.2.7	I/O B Start/Stop Logic	0	4		2 *	363	See above.
P3.2.8	Fieldbus Start Logic	0	1		0	889	0 = A rising edge is necessary 1 = State
P3.2.9	Start Delay	0.000	60.000	s	0.000	524	
P3.2.10	Remote to Local Function	0	2		2	181	0 = Keep Run 1 = Keep Run & Reference 2 = Stop

\* = The selection of the application with parameter P1.2 Application gives the default value. See the default values in Chapter 12 Appendix 1.

### 5.3 GROUP 3.3: REFERENCES

**Table 39: Frequency reference parameters**

Index	Parameter	Min	Max	Unit	Default	ID	Description
P3.3.1.1	Minimum Frequency Reference	0.00	P3.3.1.2.	Hz	0.00	101	
P3.3.1.2	Maximum Frequency Reference	P3.3.1.1.	320.00	Hz	50.00 / 60.00	102	
P3.3.1.3	Positive Frequency Reference Limit	-320.0	320.0	Hz	320.00	1285	
P3.3.1.4	Negative Frequency Reference Limit	-320.0	320.0	Hz	-320.00	1286	
P3.3.1.5	I/O Control Reference A Selection	0	19		5 *	117	0 = Preset Frequency 0 1 = Keypad reference 2 = Fieldbus 3 = AI1 4 = AI2 5 = AI1+AI2 6 = PID reference 7 = Motor potentiometer 8 = Joystick reference 9 = Jogging reference 10 = Block Out.1 11 = Block Out.2 12 = Block Out.3 13 = Block Out.4 14 = Block Out.5 15 = Block Out.6 16 = Block Out.7 17 = Block Out.8 18 = Block Out.9 19 = Block Out.10
P3.3.1.6	I/O Control Reference B Selection	0	9		4 *	131	

**Table 39: Frequency reference parameters**

Index	Parameter	Min	Max	Unit	Default	ID	Description
P3.3.1.7	Keypad Control Reference Selection	0	19		2 *	121	0 = Preset Frequency 0 1 = Keypad 2 = Fieldbus 3 = AI1 4 = AI2 5 = AI1+AI2 6 = PID reference 7 = Motor potentiometer 8 = Joystick 9 = Jogging reference 10 = Block Out.1 11 = Block Out.2 12 = Block Out.3 13 = Block Out.4 14 = Block Out.5 15 = Block Out.6 16 = Block Out.7 17 = Block Out.8 18 = Block Out.9 19 = Block Out.10
P3.3.1.8	Keypad Reference	P3.3.1.1	P3.3.1.2.	Hz	0.00	184	
P3.3.1.9	Keypad Direction	0	1		0	123	0 = Forward 1 = Reverse
P3.3.1.10	Fieldbus Control Reference Selection	0	19		3 *	122	0 = Preset frequency 0 1 = Keypad 2 = Fieldbus 3 = AI1 4 = AI2 5 = AI1+AI2 6 = PID reference 7 = Motor potentiometer 8 = Joystick 9 = Jogging reference 10 = Block Out.1 11 = Block Out.2 12 = Block Out.3 13 = Block Out.4 14 = Block Out.5 15 = Block Out.6 16 = Block Out.7 17 = Block Out.8 18 = Block Out.9 19 = Block Out.10

\* = The selection of the application with parameter P1.2 Application gives the default value. See the default values in Chapter 12 Appendix 1.

**Table 40: Torque reference parameters**

Index	Parameter	Min	Max	Unit	Default	ID	Description
P3.3.2.1	Torque Reference Selection	0	26		0 *	641	0 = Not used 1 = Keypad 2 = Joystick 3 = AI1 4 = AI2 5 = AI3 6 = AI4 7 = AI5 8 = AI6 9 = ProcessDataIn 1 10 = ProcessDataIn 2 11 = ProcessDataIn 3 12 = ProcessDataIn 4 13 = ProcessDataIn 5 14 = ProcessDataIn 6 15 = ProcessDataIn 7 16 = ProcessDataIn 8 17 = Block Out.1 18 = Block Out.2 19 = Block Out.3 20 = Block Out.4 21 = Block Out.5 22 = Block Out.6 23 = Block Out.7 24 = Block Out.8 25 = Block Out.9 26 = Block Out.10
P3.3.2.2	Torque Minimum Reference	-300.0	300.0	%	0.0	643	
P3.3.2.3	Torque Maximum Reference	-300.0	300.0	%	100.0	642	
P3.3.2.4	Torque Reference Filter Time	0.00	300.00	s	0.00	1244	
P3.3.2.5	Torque Reference Dead Zone	0.0	300.0	%	0.0	1246	
P3.3.2.6	Keypad Torque Reference	0.0	P3.3.2.3	%	0.0	1439	
P3.3.2.7	Torque Control Frequency Limit	0	1		0	1278	0 = Pos/Neg frequency limits 1 = frequency reference
M3.3.2.8	Torque Control Open Loop	This menu includes 3 parameters. See table below.					

**Table 41: Torque control Open Loop parameters**

Index	Parameter	Min	Max	Unit	Default	ID	Description
P3.3.2.8.1	Open Loop Torque Control Minimum Frequency	0.0	P3.3.1.2	Hz	3.0	636	
P3.3.2.8.2	Open Loop Torque Control P Gain	0.0	32000.0		0.01	639	
P3.3.2.8.3	Open Loop Torque Control I Gain	0.0	32000.0		2.0	640	

**Table 42: Preset frequency parameters**

Index	Parameter	Min	Max	Unit	Default	ID	Description
P3.3.3.1	Preset Frequency Mode	0	1		0 *	182	0 = Binary coded 1 = Number of inputs
P3.3.3.2	Preset Frequency 0	P3.3.1.1	P3.3.1.2	Hz	5.00	180	
P3.3.3.3	Preset Frequency 1	P3.3.1.1	P3.3.1.2	Hz	10.00 *	105	
P3.3.3.4	Preset Frequency 2	P3.3.1.1	P3.3.1.2	Hz	15.00 *	106	
P3.3.3.5	Preset Frequency 3	P3.3.1.1	P3.3.1.2	Hz	20.00 *	126	
P3.3.3.6	Preset Frequency 4	P3.3.1.1	P3.3.1.2	Hz	25.00 *	127	
P3.3.3.7	Preset Frequency 5	P3.3.1.1	P3.3.1.2	Hz	30.00 *	128	
P3.3.3.8	Preset Frequency 6	P3.3.1.1	P3.3.1.2	Hz	40.00 *	129	
P3.3.3.9	Preset Frequency 7	P3.3.1.1	P3.3.1.2	Hz	50.00 *	130	
P3.3.3.10	Preset Frequency Selection 0				DigIN SlotA.4	419	
P3.3.3.11	Preset Frequency Selection 1				DigIN SlotA.5	420	
P3.3.3.12	Preset Frequency Selection 2				DigIN Slot0.1	421	

**Table 43: Motor potentiometer parameters**

Index	Parameter	Min	Max	Unit	Default	ID	Description
P3.3.4.1	Motor Potentiometer UP				DigIN Slot0.1	418	OPEN = Not active CLOSED = Active
P3.3.4.2	Motor Potentiometer DOWN				DigIN Slot0.1	417	OPEN = Not active CLOSED = Active
P3.3.4.3	Motor Potentiometer Ramp Time	0.1	500.0	Hz/s	10.0	331	
P3.3.4.4	Motor Potentiometer Reset	0	2		1	367	0 = No reset 1 = Reset if stopped 2 = Reset if powered down

**Table 44: Joystick control parameters**

Index	Parameter	Min	Max	Unit	Default	ID	Description
P3.3.5.1	Joystick Signal Selection	0	6		0	451	0 = Not Used 1 = AI1 (0-100%) 2 = AI2 (0-100%) 3 = AI3 (0-100%) 4 = AI4 (0-100%) 5 = AI5 (0-100%) 6 = AI6 (0-100%)
P3.3.5.2	Joystick Dead Zone	0.0	20.0	%	2.0	384	
P3.3.5.3	Joystick Sleep Zone	0.0	20.0	%	0.0	385	0 = Not used
P3.3.5.4	Joystick Sleep Delay	0.00	300.00	s	0.00	386	0 = Not used

**Table 45: Jogging parameters**

Index	Parameter	Min	Max	Unit	Default	ID	Description
P3.3.6.1	Enable DI Jogging	Varies	Varies		DigIN Slot0.1	532	
P3.3.6.2	Jogging Reference 1 Activation	Varies	Varies		DigIN Slot0.1	530	
P3.3.6.3	Jogging Reference 2 Activation	Varies	Varies		DigIN Slot0.1	531	
P3.3.6.4	Jogging Reference 1	-MaxRef	MaxRef	Hz	0.00	1239	
P3.3.6.5	Jogging Reference 2	-MaxRef	MaxRef	Hz	0.00	1240	
P3.3.6.6	Jogging Ramp	0.1	300.0	s	10.0	1257	

\* = The selection of the application with parameter P1.2 Application gives the default value. See the default values in Chapter 12 Appendix 1.

## 5.4 GROUP 3.4: RAMPS AND BRAKES SETUP

**Table 46: Ramp 1 setup**

Index	Parameter	Min	Max	Unit	Default	ID	Description
P3.4.1.1	Ramp 1 Shape	0.0	100.0	%	0.0	500	
P3.4.1.2	Acceleration Time 1	0.1	300.0	s	5.0	103	
P3.4.1.3	Deceleration Time 1	0.1	300.0	s	5.0	104	

**Table 47: Ramp 2 setup**

Index	Parameter	Min	Max	Unit	Default	ID	Description
P3.4.2.1	Ramp 2 Shape	0.0	100.0	%	0.0	501	
P3.4.2.2	Acceleration Time 2	0.1	300.0	s	10.0	502	
P3.4.2.3	Deceleration Time 2	0.1	300.0	s	10.0	503	
P3.4.2.4	Ramp 2 Selection	Varies	Varies		DigIN Slot0.1	408	0 = OPEN 1 = CLOSED



**Table 48: Start magnetisation parameters**

Index	Parameter	Min	Max	Unit	Default	ID	Description
P3.4.3.1	Start Magnetising Current	0.00	IL	A	IH	517	0 = Disabled
P3.4.3.2	Start Magnetising Time	0.00	600.00	s	0.00	516	

**Table 49: DC brake parameters**

Index	Parameter	Min	Max	Unit	Default	ID	Description
P3.4.4.1	DC Brake Current	0	IL	A	IH	507	0 = Disabled
P3.4.4.2	DC Braking Time at Stop	0.00	600.00	s	0.00	508	
P3.4.4.3	Frequency to Start DC Braking at Ramp Stop	0.10	10.00	Hz	1.50	515	

**Table 50: Flux braking parameters**

Index	Parameter	Min	Max	Unit	Default	ID	Description
P3.4.5.1	Flux Braking	0	1		0	520	0 = Disabled 1 = Enabled
P3.4.5.2	Flux Braking Current	0	IL	A	IH	519	

## 5.5 GROUP 3.5: I/O CONFIGURATION

**Table 51: Digital input settings**

Index	Parameter	Min	Max	Unit	Default	ID	Description
P3.5.1.1	Control Signal 1 A				DigIN SlotA.1 *	403	
P3.5.1.2	Control Signal 2 A				DigIN SlotA.2 *	404	
P3.5.1.3	Control Signal 3 A				DigIN Slot0.1	434	
P3.5.1.4	Control Signal 1 B				DigIN Slot0.1 *	423	
P3.5.1.5	Control Signal 2 B				DigIN Slot0.1 *	424	
P3.5.1.6	Control Signal 3 B				DigIN Slot0.1	435	
P3.5.1.7	I/O B Control Force				DigIN Slot0.1 *	425	CLOSED = Force the control place to I/O B.
P3.5.1.8	I/O B Reference Force				DigIN Slot0.1 *	343	CLOSED = I/O reference B (P3.3.1.6) gives the frequency reference.
P3.5.1.9	Fieldbus Control Force				DigIN Slot0.1 *	411	
P3.5.1.10	Keypad Control Force				DigIN Slot0.1 *	410	
P3.5.1.11	External Fault Close				DigIN SlotA.3 *	405	OPEN = OK CLOSED = External fault
P3.5.1.12	External Fault Open				DigIN Slot0.2	406	OPEN = External fault CLOSED = OK
P3.5.1.13	Fault Reset Close				Varies	414	CLOSED = Resets all active faults.
P3.5.1.14	Fault Reset Open				DigIN Slot0.1	213	OPEN = Resets all active faults.
P3.5.1.15	Run Enable				DigIN Slot0.2	407	

**Table 51: Digital input settings**

Index	Parameter	Min	Max	Unit	Default	ID	Description
P3.5.1.16	Run Interlock 1				DigIN Slot0.2	1041	
P3.5.1.17	Run Interlock 2				DigIN Slot0.2	1042	
P3.5.1.18	Motor Preheat ON				DigIN Slot0.1	1044	OPEN = No action. CLOSED = Uses the DC current of the motor preheat in Stop state. Used when the value of P3.18.1 is 2.
P3.5.1.19	Ramp 2 Selection				DigIN Slot0.1 *	408	OPEN = Ramp 1 Shape, Acceleration Time 1 and Deceleration Time 1. CLOSED = Ramp 2 Shape, Acceleration Time 2 and Deceleration Time 2.
P3.5.1.20	Acc/Dec Prohibit				DigIN Slot0.1	415	
P3.5.1.21	Preset Frequency Selection 0				DigIN SlotA.4 *	419	
P3.5.1.22	Preset Frequency Selection 1				Varies	420	
P3.5.1.23	Preset Frequency Selection 2				DigIN Slot0.1 *	421	
P3.5.1.24	Motor Potentiometer UP				DigIN Slot0.1 *	418	OPEN = Not active CLOSED = Active.
P3.5.1.25	Motor Potentiometer DOWN				DigIN Slot0.1 *	417	OPEN = Not active CLOSED = Active.
P3.5.1.26	Quick Stop Activation				Varies	1213	OPEN = Activated
P3.5.1.27	Timer 1				DigIN Slot0.1	447	
P3.5.1.28	Timer 2				DigIN Slot0.1	448	

**Table 51: Digital input settings**

Index	Parameter	Min	Max	Unit	Default	ID	Description
P3.5.1.29	Timer 3				DigIN Slot0.1	449	
P3.5.1.30	PID1 Setpoint Boost				DigIN Slot0.1	1046	OPEN = No boost CLOSED = Boost
P3.5.1.31	PID1 Select Setpoint				DigIN Slot0.1	1047	OPEN = Setpoint 1 CLOSED = Setpoint 2
P3.5.1.32	External PID Start Signal				DigIN Slot0.2	1049	OPEN = PID2 in stop mode CLOSED = PID2 regulating
P3.5.1.33	External PID Select Setpoint				DigIN Slot0.1	1048	OPEN = Setpoint 1 CLOSED = Setpoint 2
P3.5.1.34	Motor 1 Interlock				DigIN Slot0.1	426	OPEN = Not active CLOSED = Active
P3.5.1.35	Motor 2 Interlock				DigIN Slot0.1	427	OPEN = Not active CLOSED = Active
P3.5.1.36	Motor 3 Interlock				DigIN Slot0.1	428	OPEN = Not active CLOSED = Active
P3.5.1.37	Motor 4 Interlock				DigIN Slot0.1	429	OPEN = Not active CLOSED = Active
P3.5.1.38	Motor 5 Interlock				DigIN Slot0.1	430	OPEN = Not active CLOSED = Active
P3.5.1.39	Motor 6 Interlock				DigIN Slot0.1	486	OPEN = Not active CLOSED = Active
P3.5.1.40	Reset Maintenance Counter				DigIN Slot0.1	490	CLOSED = Reset
P3.5.1.41	Enable DI Jogging				DigIN Slot0.1	532	

**Table 51: Digital input settings**

Index	Parameter	Min	Max	Unit	Default	ID	Description
P3.5.1.42	Jogging Reference 1 Activation				DigIN Slot0.1	530	
P3.5.1.43	Jogging Reference 2 Activation				DigIN Slot0.1	531	
P3.5.1.44	Mechanical Brake Feedback				DigIN Slot0.1	1210	
P3.5.1.45	Fire Mode Activation OPEN				DigIN Slot0.2	1596	OPEN = Fire Mode active CLOSED = No action
P3.5.1.46	Fire Mode Activation CLOSE				DigIN Slot0.1	1619	OPEN = No action CLOSED = Fire Mode active
P3.5.1.47	Fire Mode Reverse				DigIN Slot0.1	1618	OPEN = Forward CLOSED = Reverse
P3.5.1.48	Auto-cleaning Activation				DigIN Slot0.1	1715	
P3.5.1.49	Parameter Set 1/2 Selection				DigIN Slot0.1	496	OPEN = Parameter set 1 CLOSED = Parameter set 2
P3.5.1.50	User Defined Fault 1 Activation				DigIN Slot0.1	15523	OPEN = No action CLOSED = Fault activated
P3.5.1.51	User Defined Fault 2 Activation				DigIN Slot0.1	15524	OPEN = No action CLOSED = Fault activated

**NOTE!**

Your option board and board setup gives the number of available analogue inputs. The standard I/O board has 2 analogue inputs.

\* = The selection of the application with parameter P1.2 Application gives the default value. See the default values in Chapter 12 Appendix 1.

**Table 52: Analogue input 1 settings**

Index	Parameter	Min	Max	Unit	Default	ID	Description
P3.5.2.1.1	AI1 Signal Selection				AnIN SlotA.1	377	
P3.5.2.1.2	AI1 Signal Filter Time	0.00	300.00	s	0.1 *	378	
P3.5.2.1.3	AI1 Signal Range	0	1		0 *	379	0 = 0...10V / 0...20mA 1 = 2...10V / 4...20mA
P3.5.2.1.4	AI1 Custom. Min	-160.00	160.00	%	0.00 *	380	
P3.5.2.1.5	AI1 Custom. Max	-160.00	160.00	%	100.00 *	381	
P3.5.2.1.6	AI1 Signal Inversion	0	1		0 *	387	0 = Normal 1 = Signal inverted

**Table 53: Analogue input 2 settings**

Index	Parameter	Min	Max	Unit	Default	ID	Description
P3.5.2.2.1	AI2 Signal Selection				AnIN SlotA.2	388	See P3.5.2.1.1.
P3.5.2.2.2	AI2 Signal Filter Time	0.00	300.00	s	0.1 *	389	See P3.5.2.1.2.
P3.5.2.2.3	AI2 Signal Range	0	1		1 *	390	See P3.5.2.1.3.
P3.5.2.2.4	AI2 Custom. Min	-160.00	160.00	%	0.00 *	391	See P3.5.2.1.4.
P3.5.2.2.5	AI2 Custom. Max	-160.00	160.00	%	100.00 *	392	See P3.5.2.1.5.
P3.5.2.2.6	AI2 Signal Inversion	0	1		0 *	398	See P3.5.2.1.6.

**Table 54: Analogue input 3 settings**

Index	Parameter	Min	Max	Unit	Default	ID	Description
P3.5.2.3.1	AI3 Signal Selection				AnIN SlotD.1	141	See P3.5.2.1.1.
P3.5.2.3.2	AI3 Signal Filter Time	0.00	300.00	s	0.1	142	See P3.5.2.1.2.
P3.5.2.3.3	AI3 Signal Range	0	1		0	143	See P3.5.2.1.3.
P3.5.2.3.4	AI3 Custom. Min	-160.00	160.00	%	0.00	144	See P3.5.2.1.4.
P3.5.2.3.5	AI3 Custom. Max	-160.00	160.00	%	100.00	145	See P3.5.2.1.5.
P3.5.2.3.6	AI3 Signal Inversion	0	1		0	151	See P3.5.2.1.6.

**Table 55: Analogue input 4 settings**

Index	Parameter	Min	Max	Unit	Default	ID	Description
P3.5.2.4.1	AI4 Signal Selection				AnIN SlotD.2	152	See P3.5.2.1.1.
P3.5.2.4.2	AI4 Signal Filter Time	0.00	300.00	s	0.1	153	See P3.5.2.1.2.
P3.5.2.4.3	AI4 Signal Range	0	1		0	154	See P3.5.2.1.3.
P3.5.2.4.4	AI4 Custom. Min	-160.00	160.00	%	0.00	155	See P3.5.2.1.4.
P3.5.2.4.5	AI4 Custom. Max	-160.00	160.00	%	100.00	156	See P3.5.2.1.5.
P3.5.2.4.6	AI4 Signal Inversion	0	1		0	162	See P3.5.2.1.6.

**Table 56: Analogue input 5 settings**

Index	Parameter	Min	Max	Unit	Default	ID	Description
P3.5.2.5.1	AI5 Signal Selection				AnIN SlotE.1	188	See P3.5.2.1.1.
P3.5.2.5.2	AI5 Signal Filter Time	0.00	300.00	s	0.1	189	See P3.5.2.1.2.
P3.5.2.5.3	AI5 Signal Range	0	1		0	190	See P3.5.2.1.3.
P3.5.2.5.4	AI5 Custom. Min	-160.00	160.00	%	0.00	191	See P3.5.2.1.4.
P3.5.2.5.5	AI5 Custom. Max	-160.00	160.00	%	100.00	192	See P3.5.2.1.5.
P3.5.2.5.6	AI5 Signal Inversion	0	1		0	198	See P3.5.2.1.6.

**Table 57: Analogue input 6 settings**

Index	Parameter	Min	Max	Unit	Default	ID	Description
P3.5.2.6.1	AI6 Signal Selection				AnIN SlotE.2	199	See P3.5.2.1.1.
P3.5.2.6.2	AI6 Signal Filter Time	0.00	300.00	s	0.1	200	See P3.5.2.1.2.
P3.5.2.6.3	AI6 Signal Range	0	1		0	201	See P3.5.2.1.3.
P3.5.2.6.4	AI6 Custom. Min	-160.00	160.00	%	0.00	202	See P3.5.2.1.4.
P3.5.2.6.5	AI6 Custom. Max	-160.00	160.00	%	100.00	203	See P3.5.2.1.5.
P3.5.2.6.6	AI6 Signal Inversion	0	1		0	209	See P3.5.2.1.6.



**Table 58: Digital output settings on standard I/O board**

Index	Parameter	Min	Max	Unit	Default	ID	Description
P3.5.3.2.1	Basic R01 Function	0	59		Varies	11001	0 = None 1 = Ready 2 = Run 3 = General fault 4 = General fault inverted 5 = General alarm 6 = Reversed 7 = At speed 8 = Thermistor fault 9 = Motor regulator active 10 = Start signal active 11 = Keypad control active 12 = I/O B control activated 13 = Limit supervision 1 14 = Limit supervision 2 15 = Fire Mode active 16 = Jogging activated 17 = Preset speed active 18 = Quick stop activated 19 = PID in Sleep mode 20 = PID soft fill active 21 = PID feedback supervision (limits) 22 = Ext. PID supervision (limits) 23 = Input press. alarm/fault

**Table 58: Digital output settings on standard I/O board**

Index	Parameter	Min	Max	Unit	Default	ID	Description
P3.5.3.2.1	Basic R01 Function	0	59		Varies	11001	24 = Frost prot. alarm/ fault 25 = Motor 1 control 26 = Motor 2 control 27 = Motor 3 control 28 = Motor 4 control 29 = Motor 5 control 30 = Motor 6 control 31 = Time Channel 1 32 = Time Channel 2 33 = Time Channel 3 34 = FB ControlWord B13 35 = FB ControlWord B14 36 = FB ControlWord B15 37 = FB Process- Data1.B0 38 = FB Process- Data1.B1 39 = FB Process- Data1.B2 40 = Maintenance alarm 41 = Maintenance fault 42 = Mechanical brake (Open brake com- mand) 43 = Mech. brake inverted 44 = Block Out.1 45 = Block Out.2

**Table 58: Digital output settings on standard I/O board**

Index	Parameter	Min	Max	Unit	Default	ID	Description
P3.5.3.2.1	Basic R01 Function	0	59		Varies	11001	46 = Block Out.3 47 = Block Out.4 48 = Block Out.5 49 = Block Out.6 50 = Block Out.7 51 = Block Out.8 52 = Block Out.9 53 = Block Out.10 54 = Jockey pump control 55 = Priming pump control 56 = Auto-cleaning active 57 = Motor Switch Open 58 = TEST (Always Closed) 59 = Motor preheat active
P3.5.3.2.2	Basic R01 ON Delay	0.00	320.00	s	0.00	11002	
P3.5.3.2.3	Basic R01 OFF Delay	0.00	320.00	s	0.00	11003	
P3.5.3.2.4	Basic R02 Function	0	56		Varies	11004	See P3.5.3.2.1.
P3.5.3.2.5	Basic R02 ON Delay	0.00	320.00	s	0.00	11005	See P3.5.3.2.2.
P3.5.3.2.6	Basic R02 OFF Delay	0.00	320.00	s	0.00	11006	See P3.5.3.2.3.
P3.5.3.2.7	Basic R03 Function	0	56		Varies	11007	See P3.5.3.2.1. Not visible if only 2 output relays are installed.

\* = The selection of the application with parameter P1.2 Application gives the default value. See the default values in Chapter 12 Appendix 1.

### THE DIGITAL OUTPUTS OF THE EXPANDER SLOTS C, D AND E

Shows only the parameters for the outputs on option boards in slots C, D and E. Make the selections as in Basic R01 Function (P3.5.3.2.1).

This group or these parameters are not visible if there are no digital outputs in slots C, D or E.

**Table 59: Standard I/O board analogue output settings**

Index	Parameter	Min	Max	Unit	Default	ID	Description
P3.5.4.1.1	A01 function	0	31		2 *	10050	0 = TEST 0% (Not used) 1 = TEST 100% 2 = Output freq (0 - fmax) 3 = Freq reference (0 - fmax) 4 = Motor speed (0 - Motor nominal speed) 5 = Output current (0 - I <sub>N</sub> Motor) 6 = Motor torque (0 - T <sub>N</sub> Motor) 7 = Motor power (0 - P <sub>N</sub> Motor) 8 = Motor voltage (0 - U <sub>N</sub> Motor) 9 = DC link voltage (0 - 1000V) 10 = PID Setpoint (0-100%) 11 = PID Feedback (0-100%) 12 = PID1 output (0-100%) 13 = Ext.PID output (0-100%) 14 = ProcessDataIn1 (0-100%) 15 = ProcessDataIn2 (0-100%) 16 = ProcessDataIn3 (0-100%)

**Table 59: Standard I/O board analogue output settings**

Index	Parameter	Min	Max	Unit	Default	ID	Description
P3.5.4.1.1	A01 function	0	31		2 *	10050	17 = ProcessDataIn4 (0-100%) 18 = ProcessDataIn5 (0-100%) 19 = ProcessDataIn6 (0-100%) 20 = ProcessDataIn7 (0-100%) 21 = ProcessDataIn8 (0-100%) 22 = Block Out.1 (0-100%) 23 = Block Out.2 (0-100%) 24 = Block Out.3 (0-100%) 25 = Block Out.4 (0-100%) 26 = Block Out.5 (0-100%) 27 = Block Out.6 (0-100%) 28 = Block Out.7 (0-100%) 29 = Block Out.8 (0-100%) 30 = Block Out.9 (0-100%) 31 = Block Out.10 (0-100%)
P3.5.4.1.2	A01 filter time	0.0	300.0	s	1.0 *	10051	0 = No filtering
P3.5.4.1.3	A01 minimum	0	1		0 *	10052	0 = 0 mA / 0V 1 = 4 mA / 2V
P3.5.4.1.4	A01 minimum scale	Varies	Varies	Varies	0.0 *	10053	
P3.5.4.1.5	A01 maximum scale	Varies	Varies	Varies	0.0 *	10054	

\* = The selection of the application with parameter P1.2 Application gives the default value. See the default values in Chapter 12 Appendix 1.

### THE ANALOGUE OUTPUTS OF THE EXPANDER SLOTS C, D AND E

Shows only the parameters for the outputs on option boards in slots C, D and E. Make the selections as in Basic A01 Function (P3.5.4.1.1).

This group or these parameters are not visible if there are no digital outputs in slots C, D or E.

## 5.6 GROUP 3.6: FIELDBUS DATA MAPPING

**Table 60: Fieldbus data mapping**

Index	Parameter	Min	Max	Unit	Default	ID	Description
P3.6.1	Fieldbus Data Out 1 Selection	0	35000		1	852	
P3.6.2	Fieldbus Data Out 2 Selection	0	35000		2	853	
P3.6.3	Fieldbus Data Out 3 Selection	0	35000		3	854	
P3.6.4	Fieldbus Data Out 4 Selection	0	35000		4	855	
P3.6.5	Fieldbus Data Out 5 Selection	0	35000		5	856	
P3.6.6	Fieldbus Data Out 6 Selection	0	35000		6	857	
P3.6.7	Fieldbus Data Out 7 Selection	0	35000		7	858	
P3.6.8	Fieldbus Data Out 8 Selection	0	35000		37	859	

**Table 61: The default values for Process Data Out in fieldbus**

Data	Default value	Scale
Process Data Out 1	Output frequency	0.01 Hz
Process Data Out 2	Motor speed	1 rpm
Process Data Out 3	Motor current	0.1 A
Process Data Out 4	Motor torque	0.1%
Process Data Out 5	Motor power	0.1%
Process Data Out 6	Motor voltage	0.1 V
Process Data Out 7	DC link voltage	1 V
Process Data Out 8	Last active fault code	1

For example, the value *2500* for Output frequency equals 25.00 Hz, because the scale is 0.01. All the monitoring values that you can find in Chapter 4.1 *Monitor group* are given the scale value.

## 5.7 GROUP 3.7: PROHIBIT FREQUENCIES

**Table 62: Prohibit frequencies**

Index	Parameter	Min	Max	Unit	Default	ID	Description
P3.7.1	Prohibit Frequency Range 1 Low Limit	-1.00	320.00	Hz	0.00	509	0 = Not used
P3.7.2	Prohibit Frequency Range 1 High Limit	0.00	320.00	Hz	0.00	510	0 = Not used
P3.7.3	Prohibit Frequency Range 2 Low Limit	0.00	320.00	Hz	0.00	511	0 = Not used
P3.7.4	Prohibit Frequency Range 2 High Limit	0.00	320.00	Hz	0.00	512	0 = Not used
P3.7.5	Prohibit Frequency Range 3 Low Limit	0.00	320.00	Hz	0.00	513	0 = Not used
P3.7.6	Prohibit Frequency Range 3 High Limit	0.00	320.00	Hz	0.00	514	0 = Not used
P3.7.7	Ramp Time Factor	0.1	10.0	Times	1.0	518	

## 5.8 GROUP 3.8: SUPERVISIONS

**Table 63: Supervision settings**

Index	Parameter	Min	Max	Unit	Default	ID	Description
P3.8.1	Supervision #1 Item Selection	0	17		0	1431	0 = Output frequency 1 = Frequency reference 2 = Motor current 3 = Motor torque 4 = Motor power 5 = DC-link voltage 6 = Analogue input 1 7 = Analogue input 2 8 = Analogue input 3 9 = Analogue input 4 10 = Analogue input 5 11 = Analogue input 6 12 = Temperature input 1 13 = Temperature input 2 14 = Temperature input 3 15 = Temperature input 4 16 = Temperature input 5 17 = Temperature input 6
P3.8.2	Supervision #1 Mode	0	2		0	1432	0 = Not used 1 = Low limit supervision 2 = High limit supervision
P3.8.3	Supervision #1 Limit	-50.00	50.00	Varies	25.00	1433	
P3.8.4	Supervision #1 Limit Hysteresis	0.00	50.00	Varies	5.00	1434	
P3.8.5	Supervision #2 Item Selection	0	17		1	1435	See P3.8.1
P3.8.6	Supervision #2 Mode	0	2		0	1436	See P3.8.2
P3.8.7	Supervision #2 Limit	-50.00	50.00	Varies	40.00	1437	
P3.8.8	Supervision #2 Limit Hysteresis	0.00	50.00	Varies	5.00	1438	



## 5.9 GROUP 3.9: PROTECTIONS

**Table 64: General protections settings**

Index	Parameter	Min	Max	Unit	Default	ID	Description
P3.9.1.2	Response to External Fault	0	3		2	701	0 = No action 1 = Alarm 2 = Fault (Stop according to stop function) 3 = Fault (Stop by coasting)
P3.9.1.3	Input Phase Fault	0	1		0	730	0 = 3-phase support 1 = 1-phase support
P3.9.1.4	Undervoltage Fault	0	1		0	727	0 = Fault stored in history 1 = Fault not stored in history
P3.9.1.5	Response to Output Phase Fault	0	3		2	702	
P3.9.1.6	Response to Field-bus Communication Fault	0	5		3	733	0 = No action 1 = Alarm 2 = Alarm + preset fault frequency (P3.9.1.13) 3 = Fault (Stop according to stop function) 4 = Fault (Stop by coasting)
P3.9.1.7	Slot Communication Fault	0	3		2	734	
P3.9.1.8	Thermistor Fault	0	3		0	732	
P3.9.1.9	PID Soft Fill Fault	0	3		2	748	
P3.9.1.10	Response to PID Supervision Fault	0	3		2	749	
P3.9.1.11	Response to External PID Supervision Fault	0	3		2	757	
P3.9.1.12	Earth Fault	0	3		3	703	
P3.9.1.13	Preset Alarm Frequency	P3.3.1.1	P3.3.1.2	Hz	25.00	183	
P3.9.1.14	Response to Safe Torque Off (STO) Fault	0	2		2	775	0 = No action 1 = Alarm 2 = Fault (Stop by coasting)

**Table 65: Motor thermal protection settings**

Index	Parameter	Min	Max	Unit	Default	ID	Description
P3.9.2.1	Motor Thermal Protection	0	3		2	704	0 = No action 1 = Alarm 2 = Fault (Stop by stop mode) 3 = Fault (Stop by coasting)
P3.9.2.2	Ambient Temperature	-20.0	100.0	°C	40.0	705	
P3.9.2.3	Zero Speed Cooling Factor	5.0	150.0	%	Varies	706	
P3.9.2.4	Motor Thermal Time Constant	1	200	min	Varies	707	
P3.9.2.5	Motor Thermal Loadability	10	150	%	100	708	

**Table 66: Motor stall protection settings**

Index	Parameter	Min	Max	Unit	Default	ID	Description
P3.9.3.1	Motor Stall Fault	0	3		0	709	0 = No action 1 = Alarm 2 = Fault (Stop according to stop mode) 3 = Fault (Stop by coasting)
P3.9.3.2	Stall Current	0.00	5.2	A	3.7	710	
P3.9.3.3	Stall Time Limit	1.00	120.00	s	15.00	711	
P3.9.3.4	Stall Frequency Limit	1.00	P3.3.1.2	Hz	25.00	712	

**Table 67: Motor underload protection settings**

Index	Parameter	Min	Max	Unit	Default	ID	Description
P3.9.4.1	Underload Fault	0	3		0	713	0 = No action 1 = Alarm 2 = Fault (Stop according to stop mode) 3 = Fault (Stop by coasting)
P3.9.4.2	Underload Protection: Field Weakening Area Load	10.0	150.0	%	50.0	714	
P3.9.4.3	Underload Protection: Zero Frequency Load	5.0	150.0	%	10.0	715	
P3.9.4.4	Underload Protection: Time Limit	2.00	600.00	s	20.00	716	

**Table 68: Quick stop settings**

Index	Parameter	Min	Max	Unit	Default	ID	Description
P3.9.5.1	Quick Stop Mode	0	2		Varies	1276	0 = Coasting 1 = Quick stop deceleration time 2 = Stop according to Stop function (P3.2.5)
P3.9.5.2	Quick Stop Activation	Varies	Varies		DigIN Slot0.2	1213	OPEN = Activated
P3.9.5.3	Quick Stop Deceleration Time	0.1	300.0	s	Varies	1256	
P3.9.5.4	Response to Quick Stop Fault	0	2		Varies	744	0 = No action 1 = Alarm 2 = Fault (Stop according to Quick stop mode)

**Table 69: Temperature input fault 1 settings**

Index	Parameter	Min	Max	Unit	Default	ID	Description
P3.9.6.1	Temperature Signal 1	0	63		0	739	B0 = Temperature Signal 1 B1 = Temperature Signal 2 B2 = Temperature Signal 3 B3 = Temperature Signal 4 B4 = Temperature Signal 5 B5 = Temperature Signal 6
P3.9.6.2	Alarm Limit 1	-30.0	200.0	°C	130.0	741	
P3.9.6.3	Fault Limit 1	-30.0	200.0	°C	155.0	742	
P3.9.6.4	Fault Limit Response 1	0	3		2	740	0 = No response 1 = Alarm 2 = Fault (Stop according to stop mode) 3 = Fault (Stop by coasting)

**NOTE!**

Temperature input settings are only available if a B8 or BH option board is installed.

**Table 70: Temperature input fault 2 settings**

Index	Parameter	Min	Max	Unit	Default	ID	Description
P3.9.6.5	Temperature Signal 2	0	63		0	763	B0 = Temperature Signal 1 B1 = Temperature Signal 2 B2 = Temperature Signal 3 B3 = Temperature Signal 4 B4 = Temperature Signal 5 B5 = Temperature Signal 6
P3.9.6.6	Alarm Limit 2	-30.0	200.0	°C	130.0	764	
P3.9.6.7	Fault Limit 2	-30.0	200.0	°C	155.0	765	
P3.9.6.8	Fault Limit Response 2	0	3		2	766	0 = No response 1 = Alarm 2 = Fault (Stop according to stop mode) 3 = Fault (Stop by coasting)

**NOTE!**

Temperature input settings are only available if a B8 or BH option board is installed.

**Table 71: AI low protection settings**

Index	Parameter	Min	Max	Unit	Default	ID	Description
P3.9.8.1	Analogue Input Low Protection	0	2			767	0 = No protection 1 = Protection enabled in Run state 2 = Protection enabled in Run and Stop state
P3.9.8.2	Analogue Input Low Fault	0	5		0	700	0 = No action 1 = Alarm 2 = Alarm + preset fault frequency (P3.9.1.13) 3 = Alarm + previous frequency reference 4 = Fault (Stop according to stop mode) 5 = Fault (Stop by coasting)

**Table 72: User Defined Fault 1**

Index	Parameter	Min	Max	Unit	Default	ID	Description
P3.9.9.1	User Defined Fault 1	N/A	N/A		DigIN Slot0.1	15523	OPEN = No operation CLOSED = Fault activated
P3.9.9.2	Response to User Defined Fault 1	N/A	N/A		Fault,Coast	15525	

**Table 73: User Defined Fault 2**

Index	Parameter	Min	Max	Unit	Default	ID	Description
P3.9.10.1	User Defined Fault 2	N/A	N/A		DigIN Slot0.1	15524	OPEN = No operation CLOSED = Fault activated
P3.9.10.2	Response to User Defined Fault 2	N/A	N/A		Fault,Coast	15526	

## 5.10 GROUP 3.10: AUTOMATIC RESET

**Table 74: Autoreset settings**

Index	Parameter	Min	Max	Unit	Default	ID	Description
P3.10.1	Automatic Reset	0	1		0	731	0 = Disabled 1 = Enabled
P3.10.2	Restart Function	0	1		1	719	0 = Flying start 1 = According to P3.2.4.
P3.10.3	Wait Time	0.10	10000.0 0	s	0.50	717	
P3.10.4	Trial Time	0.00	10000.0 0	s	60.00	718	
P3.10.5	Number of Trials	1	10		4	759	
P3.10.6	Autoreset: Under-voltage	0	1		1	720	0 = No 1 = Yes
P3.10.7	Autoreset: Overvoltage	0	1		1	721	0 = No 1 = Yes
P3.10.8	Autoreset: Overcurrent	0	1		1	722	0 = No 1 = Yes
P3.10.9	Autoreset: AI Low	0	1		1	723	0 = No 1 = Yes
P3.10.10	Autoreset: Unit Over-temperature	0	1		1	724	0 = No 1 = Yes
P3.10.11	Autoreset: Motor Overtemperature	0	1		1	725	0 = No 1 = Yes
P3.10.12	Autoreset: External Fault	0	1		0	726	0 = No 1 = Yes
P3.10.13	Autoreset: Under-load Fault	0	1		0	738	0 = No 1 = Yes

**Table 74: Autoreset settings**

Index	Parameter	Min	Max	Unit	Default	ID	Description
P3.10.14	Autoreset: PID Supervision Fault	0	1		0	776	0 = No 1 = Yes
P3.10.15	Autoreset: Ext PID Supervision Fault	0	1		0	777	0 = No 1 = Yes

## 5.11 GROUP 3.11: APPLICATION SETTINGS

**Table 75: Application settings**

Index	Parameter	Min	Max	Unit	Default	ID	Description
P3.11.1	Password	0	9999		0	1806	
P3.11.2	C/F Selection	0	1		0 *	1197	0 = Celsius 1 = Fahrenheit
P3.11.3	kW/hp Selection	0	1		0 *	1198	0 = kW 1 = hp
P3.11.4	Multimonitor View	0	2		1	1196	0 = 2x2 sections 1 = 3x2 sections 2 = 3x3 sections
P3.11.5	FUNCT Button Configuration	0	15		15	1195	B0 = Local / Remote B1 = Control Page B2 = Change Direction B3 = Quick Edit

\* = The default value in the US is 1.



## 5.12 GROUP 3.12: TIMER FUNCTIONS

**Table 76: Interval 1**

Index	Parameter	Min	Max	Unit	Default	ID	Description
P3.12.1.1	ON Time	00:00:00	23:59:59	hh:mm:ss	00:00:00	1464	
P3.12.1.2	OFF Time	00:00:00	23:59:59	hh:mm:ss	00:00:00	1465	
P3.12.1.3	Days					1466	B0 = Sunday B1 = Monday B2 = Tuesday B3 = Wednesday B4 = Thursday B5 = Friday B6 = Saturday
P3.12.1.4	Assign to Channel					1468	B0 = Time channel 1 B1 = Time channel 2 B2 = Time channel 3

**Table 77: Interval 2**

Index	Parameter	Min	Max	Unit	Default	ID	Description
P3.12.2.1	ON Time	00:00:00	23:59:59	hh:mm:ss	00:00:00	1469	See Interval 1.
P3.12.2.2	OFF Time	00:00:00	23:59:59	hh:mm:ss	00:00:00	1470	See Interval 1.
P3.12.2.3	Days					1471	See Interval 1.
P3.12.2.4	Assign to Channel					1473	See Interval 1.

**Table 78: Interval 3**

Index	Parameter	Min	Max	Unit	Default	ID	Description
P3.12.3.1	ON Time	00:00:00	23:59:59	hh:mm:ss	00:00:00	1474	See Interval 1.
P3.12.3.2	OFF Time	00:00:00	23:59:59	hh:mm:ss	00:00:00	1475	See Interval 1.
P3.12.3.3	Days					1476	See Interval 1.
P3.12.3.4	Assign to Channel					1478	See Interval 1.

**Table 79: Interval 4**

Index	Parameter	Min	Max	Unit	Default	ID	Description
P3.12.4.1	ON Time	00:00:00	23:59:59	hh:mm:ss	00:00:00	1479	See Interval 1.
P3.12.4.2	OFF Time	00:00:00	23:59:59	hh:mm:ss	00:00:00	1480	See Interval 1.
P3.12.4.3	Days					1481	See Interval 1.
P3.12.4.4	Assign to Channel					1483	See Interval 1.

**Table 80: Interval 5**

Index	Parameter	Min	Max	Unit	Default	ID	Description
P3.12.5.1	ON Time	00:00:00	23:59:59	hh:mm:ss	00:00:00	1484	See Interval 1.
P3.12.5.2	OFF Time	00:00:00	23:59:59	hh:mm:ss	00:00:00	1485	See Interval 1.
P3.12.5.3	Days					1486	See Interval 1.
P3.12.5.4	Assign to Channel					1488	See Interval 1.

**Table 81: Timer 1**

Index	Parameter	Min	Max	Unit	Default	ID	Description
P3.12.6.1	Duration	0	72000	s	0	1489	
P3.12.6.2	Timer 1				DigINSlot 0.1	447	
P3.12.6.3	Assign to Channel					1490	B0 = Time channel 1 B1 = Time channel 2 B2 = Time channel 3

**Table 82: Timer 2**

Index	Parameter	Min	Max	Unit	Default	ID	Description
P3.12.7.1	Duration	0	72000	s	0	1491	See Timer 1.
P3.12.7.2	Timer 2				DigINSlot 0.1	448	See Timer 1.
P3.12.7.3	Assign to Channel					1492	See Timer 1.

**Table 83: Timer 3**

Index	Parameter	Min	Max	Unit	Default	ID	Description
P3.12.8.1	Duration	0	72000	s	0	1493	See Timer 1.
P3.12.8.2	Timer 3				DigINSlot 0.1	449	See Timer 1.
P3.12.8.3	Assign to Channel					1494	See Timer 1.

### 5.13 GROUP 3.13: PID CONTROLLER

**Table 84: PID controller basic settings**

Index	Parameter	Min	Max	Unit	Default	ID	Description
P3.13.1.1	PID Gain	0.00	1000.00	%	100.00	118	
P3.13.1.2	PID Integration Time	0.00	600.00	s	1.00	119	
P3.13.1.3	PID Derivation Time	0.00	100.00	s	0.00	132	
P3.13.1.4	Process Unit Selection	1	38		1	1036	
P3.13.1.5	Process Unit Min	Varies	Varies	Varies	0	1033	
P3.13.1.6	Process Unit Max	Varies	Varies	Varies	100	1034	
P3.13.1.7	Process Unit Decimals	0	4		2	1035	
P3.13.1.8	Error Inversion	0	1		0	340	0 = Normal (Feedback < Setpoint -> Increase PID output) 1 = Inverted (Feedback < Setpoint -> Decrease PID output)
P3.13.1.9	Dead Band	Varies	Varies	Varies	0	1056	
P3.13.1.10	Dead Band Delay	0.00	320.00	s	0.00	1057	

**Table 85: Setpoint settings**

Index	Parameter	Min	Max	Unit	Default	ID	Description
P3.13.2.1	Keypad setpoint 1	Varies	Varies	Varies	0	167	
P3.13.2.2	Keypad setpoint 2	Varies	Varies	Varies	0	168	
P3.13.2.3	Setpoint ramp time	0.00	300.0	s	0.00	1068	
P3.13.2.4	PID setpoint boost activation	Varies	Varies		DigIN Slot0.1	1046	OPEN = No boost CLOSED = Boost
P3.13.2.5	PID select setpoint	Varies	Varies		DigIN Slot0.1	1047	OPEN = Setpoint 1 CLOSED = Setpoint 2

**Table 85: Setpoint settings**

Index	Parameter	Min	Max	Unit	Default	ID	Description
P3.13.2.6	Setpoint source 1 selection	0	32		3 *	332	0 = Not used 1 = Keypad setpoint 1 2 = Keypad setpoint 2 3 = AI1 4 = AI2 5 = AI3 6 = AI4 7 = AI5 8 = AI6 9 = ProcessDataIn1 10 = ProcessDataIn2 11 = ProcessDataIn3 12 = ProcessDataIn4 13 = ProcessDataIn5 14 = ProcessDataIn6 15 = ProcessDataIn7 16 = ProcessDataIn8 17 = Temperature input 1 18 = Temperature input 2 19 = Temperature input 3 20 = Temperature input 4 21 = Temperature input 5 22 = Temperature input 6 23 = Block Out.1 24 = Block Out.2 25 = Block Out.3 26 = Block Out.4 27 = Block Out.5 28 = Block Out.6 29 = Block Out.7 30 = Block Out.8 31 = Block Out.9 32 = Block Out.10
P3.13.2.7	Setpoint 1 minimum	-200.00	200.00	%	0.00	1069	
P3.13.2.8	Setpoint 1 maximum	-200.00	200.00	%	100.00	1070	
P3.13.2.9	Setpoint 1 boost	-2.0	2.0	x	1.0	1071	
P3.13.2.10	Setpoint source 2 selection	0	22		2	431	See P3.13.2.6.
P3.13.2.11	Setpoint 2 minimum	-200.00	200.00	%	0.00	1073	See P3.13.2.7.
P3.13.2.12	Setpoint 2 maximum	-200.00	200.00	%	100.00	1074	See P3.13.2.8.
P3.13.2.13	Setpoint 2 boost	-2.0	2.0	x	1.0	1078	See P3.13.2.9.

\* = The selection of the application with parameter P1.2 Application gives the default value.  
See the default values in Chapter *12 Appendix 1*.

**Table 86: Feedback settings**

Index	Parameter	Min	Max	Unit	Default	ID	Description
P3.13.3.1	Feedback Function	1	9		1 *	333	1 = Only Source1 in use 2 = SQRT(Source1); (Flow=Constant x SQRT(Pressure)) 3 = SQRT(Source1- Source 2) 4 = SQRT(Source 1) + SQRT (Source 2) 5 = Source 1 + Source 2 6 = Source 1 - Source 2 7 = MIN (Source 1, Source 2) 8 = MAX (Source 1, Source 2) 9 = MEAN (Source 1, Source 2)
P3.13.3.2	Feedback Function Gain	-1000.0	1000.0	%	100.0	1058	
P3.13.3.3	Feedback 1 Source Selection	0	30		2 *	334	0 = Not used 1 = AI1 2 = AI2 3 = AI3 4 = AI4 5 = AI5 6 = AI6 7 = ProcessDataIn1 8 = ProcessDataIn2 9 = ProcessDataIn3 10 = ProcessDataIn4 11 = ProcessDataIn5 12 = ProcessDataIn6 13 = ProcessDataIn7 14 = ProcessDataIn8 15 = Temperature input 1 16 = Temperature input 2 17 = Temperature input 3 18 = Temperature input 4 19 = Temperature input 5 20 = Temperature input 6 21 = Block Out.1 22 = Block Out.2 23 = Block Out.3 24 = Block Out.4 25 = Block Out.5 26 = Block Out.6 27 = Block Out.7 28 = Block Out.8 29 = Block Out.9 30 = Block Out.10

**Table 86: Feedback settings**

Index	Parameter	Min	Max	Unit	Default	ID	Description
P3.13.3.4	Feedback 1 Minimum	-200.00	200.00	%	0.00	336	
P3.13.3.5	Feedback 1 Maximum	-200.00	200.00	%	100.00	337	
P3.13.3.6	Feedback 2 Source Selection	0	20		0	335	See P3.13.3.3.
P3.13.3.7	Feedback 2 Minimum	-200.00	200.00	%	0.00	338	See P3.13.3.4.
M3.13.3.8	Feedback 2 Maximum	-200.00	200.00	%	100.00	339	See P3.13.3.5.

\* = The selection of the application with parameter P1.2 Application gives the default value. See the default values in Chapter 12 Appendix 1.

**Table 87: Feedforward settings**

Index	Parameter	Min	Max	Unit	Default	ID	Description
P3.13.4.1	Feedforward Function	1	9		1	1059	See P3.13.3.1
P3.13.4.2	Feedforward Function Gain	-1000	1000	%	100.0	1060	See P3.13.3.2
P3.13.4.3	Feedforward 1 Source Selection	0	25		0	1061	See P3.13.3.3
P3.13.4.4	Feedforward 1 Minimum	-200.00	200.00	%	0.00	1062	See P3.13.3.4
P3.13.4.5	Feedforward 1 Maximum	-200.00	200.00	%	100.00	1063	See P3.13.3.5
P3.13.4.6	Feedforward 2 Source Selection	0	25		0	1064	See P3.13.3.6
P3.13.4.7	Feedforward 2 Min	-200.00	200.00	%	0.00	1065	See P3.13.3.7
P3.13.4.8	Feedforward 2 Max	-200.00	200.00	%	100.00	1066	See P3.13.3.8



**Table 88: Sleep function settings**

Index	Parameter	Min	Max	Unit	Default	ID	Description
P3.13.5.1	SP1 Sleep Frequency	0.00	320.00	Hz	0.00	1016	
P3.13.5.2	SP1 Sleep Delay	0	300	s	0	1017	
P3.13.5.3	SP1 Wake-up Level			Varies	0.0000	1018	
P3.13.5.4	SP1 Wake-up Mode	0	1		0	1019	0 = Absolute level 1 = Relative setpoint
P3.13.5.5	SP2 Sleep Frequency	0.00	320.00	Hz	0.00	1075	See P3.13.5.1.
P3.13.5.6	SP2 Sleep Delay	0	3000	s	0	1076	See P3.13.5.2.
P3.13.5.7	SP2 Wake-up Level			Varies	0.0000	1077	See P3.13.5.3.
P3.13.5.8	SP2 Wake-up Mode	0	1		0	1020	See P3.13.5.4.

**Table 89: Feedback supervision parameters**

Index	Parameter	Min	Max	Unit	Default	ID	Description
P3.13.6.1	Enable Feedback Supervision	0	1		0	735	0 = Disabled 1 = Enabled
P3.13.6.2	Upper Limit	Varies	Varies	Varies	Varies	736	
P3.13.6.3	Lower Limit	Varies	Varies	Varies	Varies	758	
P3.13.6.4	Delay	0	30000	s	0	737	
P3.13.6.5	Response to PID Supervision Fault	0	3		2	749	0 = No action 1 = Alarm 2 = Fault (Stop according to stop mode) 3 = Fault (Stop by coasting)

**Table 90: Pressure loss compensation parameters**

Index	Parameter	Min	Max	Unit	Default	ID	Description
P3.13.7.1	Enable Setpoint 1	0	1		0	1189	0 = Disabled 1 = Enabled
P3.13.7.2	Setpoint 1 Max Compensation	Varies	Varies	Varies	Varies	1190	
P3.13.7.3	Enable Setpoint 2	0	1		0	1191	See P3.13.7.1.
P3.13.7.4	Setpoint 2 Max Compensation	Varies	Varies	Varies	Varies	1192	See P3.13.7.2.

**Table 91: Soft fill settings**

Index	Parameter	Min	Max	Unit	Default	ID	Description
P3.13.8.1	Enable Soft Fill	0	1		0	1094	0 = Disabled 1 = Enabled
P3.13.8.2	Soft Fill Frequency	0.00	50.00	Hz	20.00	1055	
P3.13.8.3	Soft Fill Level	Varies	Varies	Varies	0.0000	1095	
P3.13.8.4	Soft Fill Timeout	0	30000	s	0	1096	0 = No timeout
P3.13.8.5	PID Soft Fill Timeout Response	0	3		2	748	0 = No action 1 = Alarm 2 = Fault (Stop according to stop mode) 3 = Fault (Stop by coasting)

**Table 92: Input pressure supervision parameters**

Index	Parameter	Min	Max	Unit	Default	ID	Description
P3.13.9.1	Enable Supervision	0	1		0	1685	0 = Disabled 1 = Enabled
P3.13.9.2	Supervision Signal	0	23		0	1686	0 = Analogue input 1 1 = Analogue input 2 2 = Analogue input 3 3 = Analogue input 4 4 = Analogue input 5 5 = Analogue input 6 6 = ProcessDataIn1 (0-100%) 7 = ProcessDataIn2 (0-100%) 8 = ProcessDataIn3 (0-100%) 9 = ProcessDataIn4 (0-100%) 10 = ProcessDataIn5 (0-100%) 11 = ProcessDataIn6 (0-100%) 12 = ProcessDataIn7 (0-100%) 13 = ProcessDataIn8 (0-100%) 14 = Block Out.1 15 = Block Out.2 16 = Block Out.3 17 = Block Out.4 18 = Block Out.5 19 = Block Out.6 20 = Block Out.7 21 = Block Out.8 22 = Block Out.9 23 = Block Out.10
P3.13.9.3	Supervision Unit Selection	0	8	Varies	2	1687	
P3.13.9.4	Supervision Unit Decimals	0	4		2	1688	
P3.13.9.5	Supervision Unit Minimum Value	Varies	Varies	Varies	Varies	1689	
P3.13.9.6	Supervision Unit Maximum Value	Varies	Varies	Varies	Varies	1690	
P3.13.9.7	Supervision Alarm Level	Varies	Varies	Varies	Varies	1691	

**Table 92: Input pressure supervision parameters**

Index	Parameter	Min	Max	Unit	Default	ID	Description
P3.13.9.8	Supervision Fault Level	Varies	Varies	Varies	Varies	1692	
P3.13.9.9	Supervision Fault Delay	0.00	60.00	s	5.00	1693	
P3.13.9.10	PID Setpoint Reduction	0.0	100.0	%	10.0	1694	
V3.13.9.11	Input Pressure	Varies	Varies	Varies	Varies	1695	This monitoring value shows the actual value of the pump input pressure.

**Table 93: Frost protection parameters**

Index	Parameter	Min	Max	Unit	Default	ID	Description
P3.13.10.1	Frost Protection	0	1		0	1704	0 = Disabled 1 = Enabled
P3.13.10.2	Temperature Signal	0	29		6	1705	0 = Temperature Input 1 (-50..200 C) 1 = Temperature Input 2 (-50..200 C) 2 = Temperature Input 3 (-50..200 C) 3 = Temperature Input 4 (-50..200 C) 4 = Temperature Input 5 (-50..200 C) 5 = Temperature Input 6 (-50..200) 6 = Analogue input 1 7 = Analogue input 2 8 = Analogue input 3 9 = Analogue input 4 10 = Analogue input 5 11 = Analogue input 6 12 = ProcessDataIn1 (0-100%) 13 = ProcessDataIn2 (0-100%) 14 = ProcessDataIn3 (0-100%) 15 = ProcessDataIn4 (0-100%) 16 = ProcessDataIn5 (0-100%) 17 = ProcessDataIn6 (0-100%) 18 = ProcessDataIn7 (0-100%) 19 = ProcessDataIn8 (0-100%) 20 = Block Out.1 21 = Block Out.2 22 = Block Out.3 23 = Block Out.4 24 = Block Out.5 25 = Block Out.6 26 = Block Out.7 27 = Block Out.8 28 = Block Out.9 29 = Block Out.10
P3.13.10.3	Temperature Signal Minimum	-100.0	P3.13.10. 4	°C/°F	-50.0 (°C)	1706	

**Table 93: Frost protection parameters**

Index	Parameter	Min	Max	Unit	Default	ID	Description
P3.13.10.4	Temperature Signal Maximum	P3.13.10.3	300.0	°C/°F	200.0 (°C)	1707	
P3.13.10.5	Frost Protection Temperature	P3.13.10.3	P3.13.10.4	°C/°F	5.00	1708	
P3.13.10.6	Frost Protection Frequency	0.0	Varies	Hz	10.0	1710	
V3.13.10.7	Frost Temperature Monitoring	Varies	Varies	°C/°F		1711	The monitoring value for the measured temperature signal in the Frost protection function. Scaling value: 0.1.

## 5.14 GROUP 3.14: EXTERNAL PID CONTROLLER

**Table 94: Basic settings for the external PID controller**

Index	Parameter	Min	Max	Unit	Default	ID	Description
P3.14.1.1	Enable External PID	0	1		0	1630	0 = Disabled 1 = Enabled
P3.14.1.2	Start Signal				DigIN Slot0.2	1049	OPEN = PID2 in stop mode CLOSED = PID2 regu- lating
P3.14.1.3	Output in Stop	0.0	100.0	%	0.0	1100	
P3.14.1.4	PID Gain	0.00	1000.00	%	100.00	1631	See P3.13.1.1
P3.14.1.5	PID Integration Time	0.00	600.00	s	1.00	1632	See P3.13.1.2
P3.14.1.6	PID Derivation Time	0.00	100.00	s	0.00	1633	See P3.13.1.3
P3.14.1.7	Process Unit Selec- tion	0	37		0	1635	See P3.13.1.4
P3.14.1.8	Process Unit Min	Varies	Varies	Varies	0	1664	See P3.13.1.5
P3.14.1.9	Process Unit Max	Varies	Varies	Varies	100	1665	See P3.13.1.6
P3.14.1.10	Process Unit Deci- mals	0	4		2	1666	See P3.13.1.7
P3.14.1.11	Error Inversion	0	1		0	1636	See P3.13.1.8
P3.14.1.12	Dead Band	Varies	Varies	Varies	0.0	1637	See P3.13.1.9
P3.14.1.13	Dead Band Delay	0.00	320.00	s	0.00	1638	See P3.13.1.10

**Table 95: Setpoints of the external PID controller**

Index	Parameter	Min	Max	Unit	Default	ID	Description
P3.14.2.1	Keypad Setpoint 1	0.00	100.00	Varies	0.00	1640	See P3.13.2.1
P3.14.2.2	Keypad Setpoint 2	0.00	100.00	Varies	0.00	1641	See P3.13.2.2
P3.14.2.3	Setpoint Ramp Time	0.00	300.00	s	0.00	1642	See P3.13.2.3
P3.14.2.4	Select Setpoint	Varies	Varies		DigIN Slot0.1	1048	OPEN = Setpoint 1 CLOSED = Setpoint 2
P3.14.2.5	Setpoint Source 1 Selection	0	32		1	1643	0 = Not Used 1 = Keypad Setpoint 1 2 = Keypad Setpoint 2 3 = AI1 4 = AI2 5 = AI3 6 = AI4 7 = AI5 8 = AI6 9 = ProcessDataIn1 10 = ProcessDataIn2 11 = ProcessDataIn3 12 = ProcessDataIn4 13 = ProcessDataIn5 14 = ProcessDataIn6 15 = ProcessDataIn7 16 = ProcessDataIn8 17 = Temperature Input 1 18 = Temperature Input 2 19 = Temperature Input 3 20 = Temperature Input 4 21 = Temperature Input 5 22 = Temperature Input 6 23 = Block Out.1 24 = Block Out.2 25 = Block Out.3 26 = Block Out.4 27 = Block Out.5 28 = Block Out.6 29 = Block Out.7 30 = Block Out.8 31 = Block Out.9 32 = Block Out.10



**Table 95: Setpoints of the external PID controller**

Index	Parameter	Min	Max	Unit	Default	ID	Description
P3.14.2.5	Setpoint Source 1 Selection	0	32		1	1643	If temperature inputs are selected, you must set the values of parameters P3.14.1.8 Process Unit Min and P3.14.1.9 Process Unit Max to agree with the scale of the temperature measurement board.
P3.14.2.6	Setpoint 1 minimum	-200.00	200.00	%	0.00	1644	
P3.14.2.7	Setpoint 1 maximum	-200.00	200.00	%	100.00	1645	
P3.14.2.8	Setpoint source 2 selection	0	22		0	1646	See P3.14.2.5.
P3.14.2.9	Setpoint 2 minimum	-200.00	200.00	%	0.00	1647	
P3.14.2.10	Setpoint 2 maximum	-200.00	200.00	%	100.00	1648	

**Table 96: Feedback of the external PID controller**

Index	Parameter	Min	Max	Unit	Default	ID	Description
P3.14.3.1	Feedback Function	1	9		1	1650	
P3.14.3.2	Feedback Function Gain	-1000.0	1000.0	%	100.0	1651	
P3.14.3.3	Feedback 1 Source Selection	0	25		1	1652	See P3.13.3.3.
P3.14.3.4	Feedback 1 Minimum	-200.00	200.00	%	0.00	1653	
P3.14.3.5	Feedback 1 Maximum	-200.00	200.00	%	100.00	1654	
P3.14.3.6	Feedback 2 Source Selection	0	25		2	1655	See P3.13.3.6.
P3.14.3.7	Feedback 2 Minimum	-200.00	200.00	%	0.00	1656	
P3.14.3.8	Feedback 2 Maximum	-200.00	200.00	%	100.00	1657	

**Table 97: Process supervision of the external PID controller**

Index	Parameter	Min	Max	Unit	Default	ID	Description
P3.14.4.1	Enable Supervision	0	1		0	1659	0 = Disabled 1 = Enabled
P3.14.4.2	Upper Limit	Varies	Varies	Varies	Varies	1660	
P3.14.4.3	Lower Limit	Varies	Varies	Varies	Varies	1661	
P3.14.4.4	Delay	0	30000	s	0	1662	
P3.14.4.5	Response to External PID Supervision Fault	0	3		2	757	See P3.9.1.11.

## 5.15 GROUP 3.15: MULTI-PUMP

**Table 98: Multi-pump parameters**

Index	Parameter	Min	Max	Unit	Default	ID	Description
P3.15.1	Number of Motors	1	6		1	1001	
P3.15.2	Interlock Function	0	1		1	1032	0 = Disabled 1 = Enabled
P3.15.3	Include FC	0	1		1	1028	0 = Disabled 1 = Enabled
P3.15.4	Autochange	0	1		1	1027	0 = Disabled 1 = Enabled
P3.15.5	Autochange Interval	0.0	3000.0	h	48.0	1029	
P3.15.6	Autochange: Frequency Limit	0.00	P3.3.1.2	Hz	25.00	1031	
P3.15.7	Autochange: Motor Limit	1	6		1	1030	
P3.15.8	Bandwidth	0	100	%	10	1097	
P3.15.9	Bandwidth Delay	0	3600	s	10	1098	
P3.15.10	Motor 1 Interlock	Varies	Varies		DigIN Slot0.1	426	OPEN = Not active CLOSED = Active
P3.15.11	Motor 2 Interlock	Varies	Varies		DigIN Slot0.1	427	See P3.15.10
P3.15.12	Motor 3 Interlock	Varies	Varies		DigIN Slot0.1	428	See P3.15.10
P3.15.13	Motor 4 Interlock	Varies	Varies		DigIN Slot0.1	429	See P3.15.10
P3.15.14	Motor 5 Interlock	Varies	Varies		DigIN Slot0.1	430	See P3.15.10
P3.15.15	Motor 6 Interlock	Varies	Varies		DigIN Slot0.1	486	See P3.15.10
M3.15.16	Overpressure Supervision	See the overpressure supervision parameters below.					

**Table 99: Overpressure supervision parameters**

Index	Parameter	Min	Max	Unit	Default	ID	Description
P3.15.16.1	Enable Overpressure Supervision	0	1		0	1698	0 = Disabled 1 = Enabled
P3.15.16.2	Supervision Alarm Level	P3.13.1.5	P3.13.1.6	P3.13.1.4	0.00	1699	

## 5.16 GROUP 3.16: MAINTENANCE COUNTERS

**Table 100: Maintenance counters**

Index	Parameter	Min	Max	Unit	Default	ID	Description
P3.16.1	Counter 1 Mode	0	2		0	1104	0 = Not used 1 = Hours 2 = Revolutions * 1000
P3.16.2	Counter 1 Alarm Limit	0	2147483647	h/kRev	0	1105	0 = Not used
P3.16.3	Counter 1 Fault Limit	0	2147483647	h/kRev	0	1106	0 = Not used
B3.16.4	Counter 1 Reset	0	1		0	1107	
P3.16.5	Counter 1 DI Reset	Varies	Varies		0	490	CLOSED = Reset

## 5.17 GROUP 3.17: FIRE MODE

**Table 101: Fire mode parameters**

Index	Parameter	Min	Max	Unit	Default	ID	Description
P3.17.1	Fire Mode Password	0	9999		0	1599	1002 = Enabled 1234 = Test mode
P3.17.2	Fire Mode Frequency Source	0	18		0	1617	0 = Fire Mode frequency 1 = Preset speeds 2 = Keypad 3 = Fieldbus 4 = AI1 5 = AI2 6 = AI1 + AI2 7 = PID1 8 = Motor potentiometer 9 = Block Out.1 10 = Block Out.2 11 = Block Out.3 12 = Block Out.4 13 = Block Out.5 14 = Block Out.6 15 = Block Out.7 16 = Block Out.8 17 = Block Out.9 18 = Block Out.10
P3.17.3	Fire Mode Frequency	8.00	P3.3.1.2	Hz	50.00	1598	
P3.17.4	Fire Mode Activation on OPEN				DigIN Slot0.2	1596	OPEN = Fire Mode active CLOSED = No action
P3.17.5	Fire Mode Activation on CLOSE				DigIN Slot0.1	1619	OPEN = No action CLOSED = Fire Mode active
P3.17.6	Fire Mode Reverse				DigIN Slot0.1	1618	OPEN = Forward CLOSED = Reverse DigIN Slot0.1 = Forward DigIN Slot0.2 = Reverse
V3.17.7	Fire Mode Status	0	3		0	1597	See Table 21 Items in the monitoring menu. 0 = Disabled 1 = Enabled 2 = Activated (Enabled + DI Open) 3 = Test Mode
V3.17.8	Fire Mode Counter					1679	

## 5.18 GROUP 3.18: MOTOR PREHEAT PARAMETERS

**Table 102: Motor preheat parameters**

Index	Parameter	Min	Max	Unit	Default	ID	Description
P3.18.1	Motor Preheat Function	0	4		0	1225	0 = Not used 1 = Always in stop state 2 = Controlled by DI 3 = Temperature limit 4 = Temperature limit (Measured motor temperature)
P3.18.2	Preheat Temperature Limit	-20	100	°C	0	1226	
P3.18.3	Motor Preheat Current	0	31048	A	Varies	1227	
P3.18.4	Motor Preheat ON	Varies	Varies		DigIN Slot0.1	1044	OPEN = No action CLOSED = Preheat activated in Stop state
P3.18.5	Preheat Motor Temperature	0	6		0	1045	0 = Not Used 1 = Temperature Input 1 2 = Temperature Input 2 3 = Temperature Input 3 4 = Temperature Input 4 5 = Temperature Input 5 6 = Temperature Input 6

## 5.19 GROUP 3.19: DRIVE CUSTOMIZER

**Table 103: Drive Customizer parameters**

Index	Parameter	Min	Max	Unit	Default	ID	Description
P3.19.1	Operation Mode	N/A	N/A		Programming	15001	Please use the graphical Drive Customizer tool in Vacon Live.

## 5.20 GROUP 3.20: MECHANICAL BRAKE

**Table 104: Mechanical brake parameters**

Index	Parameter	Min	Max	Unit	Default	ID	Description
P3.20.1	Brake Control	0	2		0	1541	0 = Disabled 1 = Enabled 2 = Enabled with brake status supervision
P3.20.2	Brake Mechanical Delay	0.00	60.00	s	0.00	353	
P3.20.3	Brake Opening Frequency Limit	P3.20.4	P3.3.1.2	Hz	2.00	1535	
P3.20.4	Brake Closing Frequency Limit	P3.3.1.1	P3.3.1.2	Hz	2.00	1539	
P3.20.5	Brake Current Limit	0.0	Varies	A	0.0	1085	
P3.20.6	Brake Fault Delay	0.00	60.00	s	2.00	352	
P3.20.7	Response to Brake Fault	0	3		0	1316	0 = No action 1 = Alarm 2 = Fault (Stop according to stop mode) 3 = Fault (Stop by coasting)
P3.20.8	Brake Feedback				DigIN Slot0.1	1210	

## 5.21 GROUP 3.21: PUMP CONTROL

**Table 105: Auto-cleaning parameters**

Index	Parameter	Min	Max	Unit	Default	ID	Description
P3.21.1.1	Cleaning Function	0	1		0	1714	0 = Disabled 1 = Enabled
P3.21.1.2	Cleaning Activation				DigIN Slot0.1	1715	
P3.21.1.3	Cleaning Cycles	1	100		5	1716	
P3.21.1.4	Clean Forward Frequency	0.00	50.00	Hz	45.00	1717	
P3.21.1.5	Clean Forward Time	0.00	320.00	s	2.00	1718	
P3.21.1.6	Clean Reverse Frequency	0.00	50.00	Hz	45.00	1719	
P3.21.1.7	Clean Reverse Time	0.00	320.00	s	0.00	1720	
P3.21.1.8	Cleaning Acceleration Time	0.1	300.0	s	0.1	1721	
P3.21.1.9	Cleaning Deceleration Time	0.1	300.0	s	0.1	1722	

**Table 106: Jockey pump parameters**

Index	Parameter	Min	Max	Unit	Default	ID	Description
P3.21.2.1	Jockey Function	0	2		0	1674	0 = Not used 1 = PID sleep 2 = PID sleep (level)
P3.21.2.2	Jockey Start Level	0.00	100.00	%	0.00	1675	
P3.21.2.3	Jockey Stop Level	0.00	100.00	%	0.00	1676	

**Table 107: Priming pump parameters**

Index	Parameter	Min	Max	Unit	Default	ID	Description
P3.21.3.1	Priming Function	0	1		0	1677	0 = Disabled 1 = Enabled
P3.21.3.2	Priming Time	0.0	320.00		3.0	1678	



## 6 DIAGNOSTICS MENU

### 6.1 ACTIVE FAULTS

When there is a fault or many faults, the display shows the name of the fault and blinks. Push OK to go back to the Diagnostics menu. The submenu Active faults shows the number of faults. To see the fault-time data, make a selection of a fault and push OK.

The fault stays active until you reset it. There are 5 ways to reset a fault.

- Push the Reset button for 2 s.
- Go into the submenu Reset faults and use the parameter Reset Faults.
- Give a reset signal in the I/O terminal.
- Give a reset signal with the fieldbus.
- Give a reset signal in Vacon Live.

The Active faults submenu can keep a storage of maximum 10 faults. The submenu shows the faults in the sequence in which they occurred.

### 6.2 RESET FAULTS

In this menu, you can reset faults. See instructions in Chapter 11.1 *A fault comes into view*.



#### CAUTION!

Before you reset the fault, remove the external Control signal to prevent that you restart the drive accidentally.

### 6.3 FAULT HISTORY

You can see 40 faults in the Fault history.

To see the details of a fault, go into Fault history, find the fault and push OK.

### 6.4 TOTAL COUNTERS

If you read a counter value through fieldbus, see Chapter 11.4 *Total and trip counters*.

**Table 108: The total counter parameters in the diagnostics menu**

Index	Parameter	Min	Max	Unit	Default	ID	Description
V4.4.1	Energy Counter			Varies		2291	The quantity of energy taken from the supply network. You cannot reset the counter. In the text display: the highest energy unit that the display shows is MW. If the counted energy becomes more than 999.9 MW, no unit shows on the display.
V4.4.3	Operating Time (graphical keypad)			a d hh:min		2298	The operating time of the control unit.
V4.4.4	Operating Time (text keypad)			a			The operating time of the control unit in total years.
V4.4.5	Operating Time (text keypad)			d			The operating time of the control unit in total days.
V4.4.6	Operating Time (text keypad)			hh:min: ss			The operating time of the control unit in hours, minutes and seconds.
V4.4.7	Run Time (graphical keypad)			a d hh:min		2293	The motor run time.
V4.4.8	Run Time (text keypad)			a			The motor run time in total years.
V4.4.9	Run Time (text keypad)			d			The motor run time in total days.
V4.4.10	Run Time (text keypad)			hh:min: ss			The motor run time in hours, minutes and seconds.
V4.4.11	Power On Time (graphical keypad)			a d hh:min		2294	The quantity of time that the power unit has been powered on. You cannot reset the counter.
V4.4.12	Power On Time (text keypad)			a			The power on time in total years.
V4.4.13	Power On Time (text keypad)			d			The power on time in total days.

**Table 108: The total counter parameters in the diagnostics menu**

Index	Parameter	Min	Max	Unit	Default	ID	Description
V4.4.14	Power On Time (text keypad)			hh:min:ss			The power on time in hours, minutes and seconds.
V4.4.15	Start Command Counter					2295	The number of times that the power unit has been started.

## 6.5 TRIP COUNTERS

If you read a counter value through fieldbus, see Chapter 11.4 *Total and trip counters*.

**Table 109: The trip counter parameters in the diagnostics menu**

Index	Parameter	Min	Max	Unit	Default	ID	Description
P4.5.1	Energy Trip Counter			Varies		2296	<p>You can reset this counter. In the text display: the highest energy unit that the display shows is MW. If the counted energy becomes more than 999.9 MW, no unit shows on the display.</p> <p><b>Resetting the counter</b></p> <ul style="list-style-type: none"> <li>In the text display: Push the OK button for 4 s.</li> <li>In the graphical display: Push OK. A Reset counter page shows. Push OK again.</li> </ul>
P4.5.3	Operating Time (graphical keypad)			a d hh:min		2299	You can reset this counter. See instructions in P4.5.1 above.
P4.5.4	Operating Time (text keypad)			a			The operating time in total years.
P4.5.5	Operating Time (text keypad)			d			The operating time in total days.
P4.5.6	Operating Time (text keypad)			hh:min:ss			The operating time in hours, minutes and seconds.

## 6.6 SOFTWARE INFO

**Table 110: The software info parameters in the diagnostics menu**

Index	Parameter	Min	Max	Unit	Default	ID	Description
V4.6.1	Software Package (graphical keypad)						The code for the software identification
V4.6.2	Software Package ID (text keypad)						
V4.6.3	Software Package Version (text keypad)						
V4.6.4	System Load	0	100	%		2300	The load on the control unit CPU
V4.6.5	Application Name (graphical keypad)						The name of the application
V4.6.6	Application ID						The code of the application
V4.6.7	Application Version						

## **7 I/O AND HARDWARE MENU**

In the I/O and Hardware menu, there are different settings that are related to the options. The values in this menu are raw values, that is, they are not scaled by the application.

### **7.1 BASIC I/O**

In the Basic I/O menu, you can monitor the statuses of the inputs and the outputs.

**Table 111: The basic I/O parameters in the I/O and Hardware menu**

Index	Parameter	Min	Max	Unit	Default	ID	Description
V5.1.1	Digital Input 1	0	1		0		Status of the digital input signal
V5.1.2	Digital Input 2	0	1		0		Status of the digital input signal
V5.1.3	Digital Input 3	0	1		0		Status of the digital input signal
V5.1.4	Digital Input 4	0	1		0		Status of the digital input signal
V5.1.5	Digital Input 5	0	1		0		Status of the digital input signal
V5.1.6	Digital Input 6	0	1		0		Status of the digital input signal
V5.1.7	Analogue Input 1 Mode	1	3		3		Shows the mode that is set for the analogue input signal. The selection is made with a DIP switch on the control board.  1 = 0...20mA 3 = 0...10V
V5.1.8	Analogue Input 1	0	100	%	0.00		Status of the analogue input signal
V5.1.9	Analogue Input 2 Mode	1	3		3		Shows the mode that is set for the analogue input signal. The selection is made with a DIP switch on the control board.  1 = 0...20mA 3 = 0...10V
V5.1.10	Analogue Input 2	0	100	%	0.00		Status of the analogue input signal

**Table 111: The basic I/O parameters in the I/O and Hardware menu**

Index	Parameter	Min	Max	Unit	Default	ID	Description
V5.1.11	Analogue Output 1 Mode	1	3		1		Shows the mode that is set for the analogue input signal. The selection is made with a DIP switch on the control board.  1 = 0...20mA 3 = 0...10V
V5.1.12	Analogue Output 1	0	100	%	0.00		Status of the analogue output signal
V5.1.13	Relay Output 1	0	1		0		Status of the relay output signal
V5.1.14	Relay Output 2	0	1		0		Status of the relay output signal
V5.1.15	Relay Output 3	0	1		0		Status of the relay output signal

## 7.2 OPTION BOARD SLOTS

The parameters in this menu are different for all the option boards. You see the parameters of the option board that you installed. If there is no option board in the slots C, D or E, you do not see parameters. See more about the location of the slots in Chapter 10.6.1 *Programming of digital and analogue inputs*.

When you remove an option board, the fault code 39 and the fault name *Device removed* show on the display. See Chapter 11.3 *Fault codes*.

**Table 112: Option board related parameters**

Menu	Function	Description
Slot C	Settings	The settings that are related to the option board
	Monitoring	Monitor the data that is related to the option board
Slot D	Settings	The settings that are related to the option board
	Monitoring	Monitor the data that is related to the option board
Slot E	Settings	The settings that are related to the option board
	Monitoring	Monitor the data that is related to the option board

## 7.3 REAL TIME CLOCK

**Table 113: The real time clock parameters in the I/O and Hardware menu**

Index	Parameter	Min	Max	Unit	Default	ID	Description
V5.5.1	Battery State	1	3			2205	Status of the battery. 1 = Not installed 2 = Installed 3 = Replace the battery
P5.5.2	Time			hh:mm:ss		2201	The current time of the day
P5.5.3	Date			dd.mm.		2202	The current date
P5.5.4	Year			yyyy		2203	The current year
P5.5.5	Daylight Saving	1	4		1	2204	The daylight saving rule  1 = Off 2 = EU: starts on the last Sunday in March, ends on the last Sunday in October 3 = US: starts on the 2nd Sunday in March, ends on the 1st Sunday in November 4 = Russia (permanent)

## 7.4 POWER UNIT SETTINGS

In this menu, you can change the settings of the fan, the brake chopper and the sine filter.

The fan operates in the optimised or the always on mode. In the optimised mode, the internal logic of the drive receives data about the temperature and controls the fan speed. After the drive goes in the Ready state, the fan stops in 5 minutes. In the always on mode, the fan operates in full speed, and does not stop.

The Sine filter keeps the overmodulation depth in limits and does not let the thermal management functions decrease the switching frequency.



**Table 114: Power unit settings**

Index	Parameter	Min	Max	Unit	Default	ID	Description
P5.6.1.1	Fan Control Mode	0	1		1	2377	0 = Always on 1 = Optimised
P5.6.2.1	Brake Chopper Mode	0	3		0		0 = Disabled 1 = Enabled (Run) 2 = Enabled (Run & Stop) 3 = Enabled (Run, no testing)
P5.6.4.1	Sine Filter	0	1		0		0 = Not used 1 = In use

## 7.5 KEYPAD

**Table 115: The keypad parameters in the I/O and Hardware menu**

Index	Parameter	Min	Max	Unit	Default	ID	Description
P5.7.1	Timeout Time	0	60	min	0		The time after which the display goes back to the page that is set with parameter P5.7.2.  0 = Not used
P5.7.2	Default Page	0	4		0		The page that the display shows when the drive is powered up, or when the time that is set with P5.7.1 is expired. If the value is set to 0, the display shows the last page that it showed.  0 = None 1 = A menu index 2 = Main menu 3 = Control page 4 = Multimonitor
P5.7.3	Menu Index						Set a page to be the menu index. (The selection 1 in P5.7.2.)
P5.7.4	Contrast *	30	70	%	50		Set the contrast of the display.
P5.7.5	Backlight Time	0	60	min	5		Set the time after which the backlight of the display turns off. If the value is set to 0, the backlight is always on.

\* Only available with the graphical keypad.

## 7.6 FIELDBUS

In the I/O and Hardware menu, there are the parameters that are related to fieldbus boards. You can find the instructions on how to use these parameters in the related fieldbus manual.

Submenu level 1	Submenu level 2	Submenu level 3	Submenu level 4
RS-485	Common settings	Protocol	Modbus RTU
			N2
			Bacnet MSTP
RS-485	Modbus RTU	Parameters	Slave address
			Baud rate
			Parity type
			Stop bits
			Communication timeout
			Operate mode
		Monitoring	Fieldbus protocol status
			Communication status
			Illegal functions
			Illegal data addresses
			Illegal data values
			Slave device busy
			Memory parity error
			Slave device failure
			Last fault response
			Control Word
			Status Word

Submenu level 1	Submenu level 2	Submenu level 3	Submenu level 4
RS-485	N2	Parameters	Slave address
			Communication timeout
		Monitoring	Fieldbus protocol status
			Communication status
			Invalid data
			Invalid commands
			Command not accepted
			Control word
Status word			
RS-485	Bacnet MSTP	Parameters	Baud rate
			Autobauding
			MAC address
			Instance number
			Communication timeout
		Monitoring	Fieldbus protocol status
			Communication status
			Actual instance number
			Fault code
			Control word
Status word			
Ethernet	Common settings	IP address mode	
		Fixed IP	IP address
			Subnet mask
			Default gateway
		IP address	
		Subnet mask	
		Default gateway	
MAC address			

Submenu level 1	Submenu level 2	Submenu level 3	Submenu level 4
Ethernet	Modbus TCP	Parameters	Connection limit
			Unit Identifier number
			Communication timeout
		Monitoring	Fieldbus protocol status
			Communication status
			Illegal functions
			Illegal data addresses
			Illegal data values
			Slave device busy
			Memory parity error
			Slave device failure
			Last fault response
			Control word
			Status word
Ethernet	Bacnet IP	Parameters	Instance number
			Communication timeout
			Protocol in use
			BBMD IP
			BBMD Port
			Time to live
		Monitoring	Fieldbus protocol status
			Communication status
			Actual instance number
			Control word
			Status word

Submenu level 1	Submenu level 2	Submenu level 3	Submenu level 4
Ethernet	Ethernet/ IP	Parameters	Protocol in use
			Output Instance
			Input Instance
			Communication Timeout
		Monitoring	Reset Counters
			Open Request
			Open Format Reject
			Open Resource Rejects
			Open Other Rejects
			Close Requests
			Close Format Rejects
			Close Other Rejects
			Connection Timeouts
			Communication Status
			Control Word
			Status Word
Fieldbus Protocol Status			
Ethernet	Profinet IO	Parameters	Protocol in use
			Communication timeout
		Monitoring	FB Protocol Status
			Comm. Status
			Setpoint Telegram
			Actual Value Telegram
			Number of Process Data
			Control Word
			Status Word
			Connection Timeouts
Parameter accesses			

## 8 USER SETTINGS, FAVOURITES AND USER LEVEL MENUS

### 8.1 USER SETTINGS

**Table 116: General settings in the user settings menu**

Index	Parameter	Min	Max	Unit	Default	ID	Description
P6.1	Language selection	Varies	Varies		Varies	802	The selection is different in all the language packages
M6.5	Parameter backup						See 8.1.1 Parameter backup.
M6.6	Parameter compare						
P6.7	Drive name						Use Vacon Live PC tool to give a name to the drive if you think that it is necessary.

### 8.1.1 PARAMETER BACKUP

**Table 117: The parameter backup parameters in the user settings menu**

Index	Parameter	Min	Max	Unit	Default	ID	Description
P6.5.1	Restore Factory Defaults					831	Restores the default parameter values and starts the Startup wizard.
P6.5.2	Save to Keypad *	0	1		0		Saves the parameter values to the control panel, for example to copy them to another drive.  0 = No 1 = Yes
P6.5.3	Restore from Keypad *						Loads the parameter values from the control panel to the drive.
B6.5.4	Save to Set 1						Keeps a customised parameter set (that is, all the parameters included in the application).
B6.5.5	Restore from Set 1						Loads the customised parameter set to the drive.
B6.5.6	Save to Set 2						Keeps another customised parameter set (that is, all the parameters included in the application).
B6.5.7	Restore from Set 2						Loads the customised parameter set 2 to the drive.

\* Only available with the graphical display.

### 8.2 FAVOURITES



**NOTE!**

This menu is available on the control panel with the graphical display, but not on the control panel with the text display.



**NOTE!**

This menu is not available in the Vacon Live tool.



If you use the same items frequently, you can add them into Favourites. You can collect a set of parameters or monitoring signals from all the keypad menus. It is not necessary to find them in the menu structure one by one. As an alternative, add them into the Favourites folder where it is easy to find them.

### ADDING AN ITEM TO THE FAVOURITES

- 1 Find the item that you want to add to Favourites. Push the OK button.

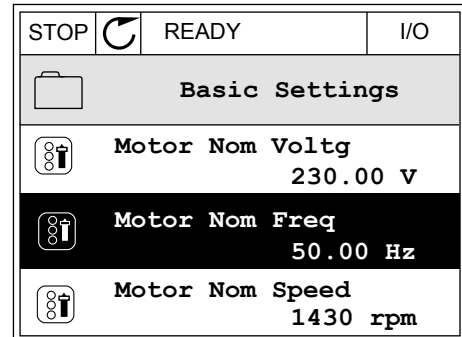

- 2 Make a selection of *Add to favourites* and push the OK button.

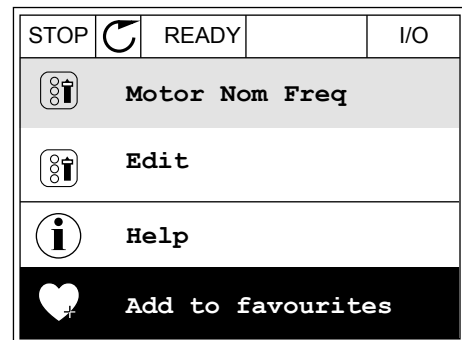

- 3 The steps are now completed. To continue, read the instructions on the display.

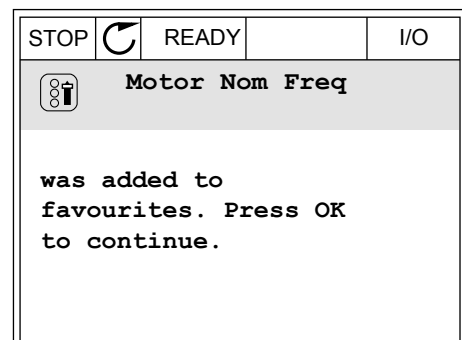

### REMOVING AN ITEM FROM THE FAVOURITES

- 1 Go to the Favourites.

- 2 Find the item that you want to remove. Push the OK button.

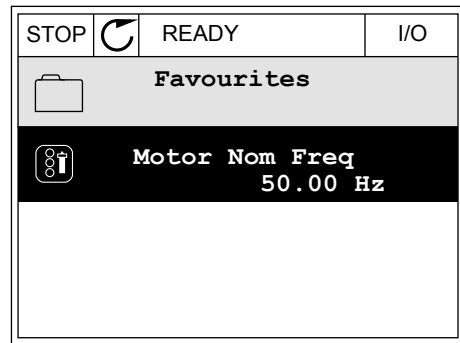

- 3 Make a selection of *Rem from favourites*.

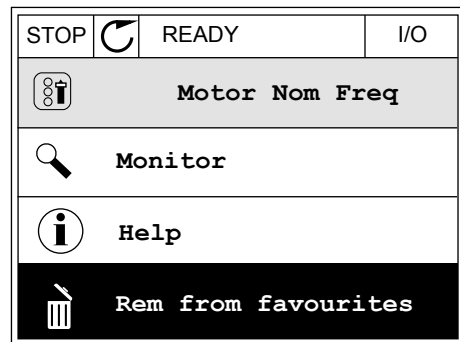

- 4 To remove the item, push the OK button again.

### 8.3 USER LEVELS

Use the User level parameters to keep the personnel who are not approved from making changes in the parameters. You can also prevent accidental changes in the parameters.

When you make a selection of a user level, the user cannot see all the parameters on the display of the control panel.

**Table 118: The user level parameters**

Index	Parameter	Min	Max	Unit	Default	ID	Description
P8.1	User Level	1	3		1	1194	1 = Normal. All the menus are visible in the main menu. 2 = Monitoring. Only the monitoring and user level menus are visible in the main menu. 3 = Favourites. Only the favourites and user level menus are visible in the main menu.
P8.2	Access Code	0	99999		0	2362	If you set the value to be to other than 0 before you go to <i>Monitoring</i> from, for example, <i>Normal</i> , you have to give the access code when you go back to <i>Normal</i> . This prevents personnel who are not approved from making changes in the parameters on the control panel.



**CAUTION!**

Do not lose the access code. If the access code is lost, contact your nearest service center or partner.

**CHANGING THE ACCESS CODE OF THE USER LEVELS**

- 1 Go to the User levels.
- 2 Go to the item Access code and push the arrow button Right.

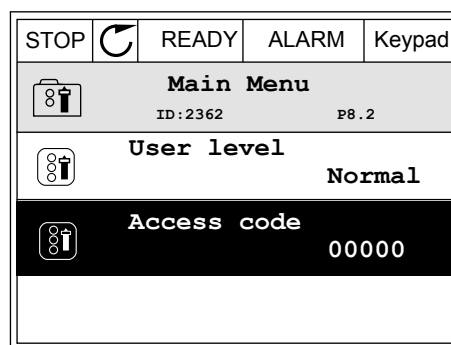

- To change the digits of the access code, use all the arrow buttons.

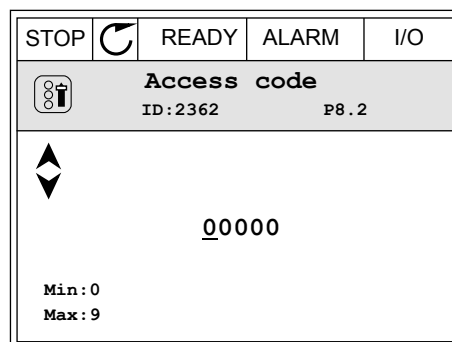

- Accept the change with the OK button.

## 9 MONITORING VALUE DESCRIPTIONS

This chapter gives you the basic descriptions of all monitoring values.

### 9.1 MULTIMONITOR

#### ***V2.1.1 FREQUENCY REFERENCE (ID 25)***

This monitoring value shows the actual frequency reference to the motor control. The value is updated at 10 ms interval.

#### ***V2.1.2 OUTPUT FREQUENCY (ID 1)***

This monitoring value shows the actual output frequency to the motor.

#### ***V2.1.3 MOTOR CURRENT (ID 3)***

This monitoring value shows the measured current of the motor. The scaling of the value is different for different drive sizes.

#### ***V2.1.4 MOTOR SPEED (ID 2)***

This monitoring value shows the actual speed of the motor in rpm (calculated value).

#### ***V2.1.5 MOTOR TORQUE (ID 4)***

This monitoring value shows the actual torque of the motor (calculated value).

#### ***V2.1.6 MOTOR POWER (ID 5)***

This monitoring value shows the actual shaft power of the motor (calculated value) as a percentage of the motor nominal power.

#### ***V2.1.7 MOTOR VOLTAGE (ID 6)***

This monitoring value shows the actual output voltage to the motor.

#### ***V2.1.8 DC-LINK VOLTAGE (ID 7)***

This monitoring value shows the measured voltage in the DC-link of the drive.

#### ***V2.1.9 UNIT TEMPERATURE (ID 8)***

This monitoring value shows the measured heatsink temperature of the drive. The unit of measurement is degrees celsius or fahrenheit, depending on the 'C/F Selection' parameter value.

## 9.2 BASIC

### **V2.3.1 OUTPUT FREQUENCY (ID 1)**

This monitoring value shows the actual output frequency to the motor.

### **V2.3.2 FREQUENCY REFERENCE (ID 25)**

This monitoring value shows the actual frequency reference to the motor control.  
The value is updated at 10 ms interval.

### **V2.3.3 MOTOR SPEED (ID 2)**

This monitoring value shows the actual speed of the motor in rpm (calculated value).

### **V2.3.4 MOTOR CURRENT (ID 3)**

This monitoring value shows the measured current of the motor.  
The scaling of the value is different for different drive sizes.

### **V2.3.5 MOTOR TORQUE (ID 4)**

This monitoring value shows the actual torque of the motor (calculated value).

### **V2.3.7 MOTOR SHAFT POWER (ID 5)**

This monitoring value shows the actual shaft power of the motor (calculated value) as a percentage of the motor nominal power.

### **V2.3.8 MOTOR SHAFT POWER (ID 73)**

This monitoring value shows the actual shaft power of the motor (calculated value).  
The unit of measurement is kW or hp, depending on the 'kW/hp Selection' parameter value.

### **V2.3.9 MOTOR VOLTAGE (ID 6)**

This monitoring value shows the actual output voltage to the motor.

### **V2.3.10 DC LINK VOLTAGE (ID 7)**

This monitoring value shows the measured voltage in the DC-link of the drive.

### **V2.3.11 UNIT TEMPERATURE (ID 8)**

This monitoring value shows the measured heatsink temperature of the drive.  
The unit of the monitoring value is celsius degrees or fahrenheit degrees, depending on the 'C/F Selection' parameter value.

### **V2.3.12 MOTOR TEMPERATURE (ID 9)**

This monitoring value shows the calculated motor temperature in percentage of the nominal working temperature.  
When the value rises above 105%, motor thermal protection fault occurs.

**V2.3.13 MOTOR PREHEAT (ID 1228)**

This monitoring value shows the status of the motor preheat function.

**V2.3.14 TORQUE REFERENCE (ID 18)**

This monitoring value shows the final torque reference for motor control.

**9.3 I/O****V2.4.1 SLOTA DIN 1,2,3 (ID 15)**

This monitoring value shows the status of the digital inputs 1-3 in slot A (standard I/O).

**V2.4.2 SLOTA DIN 4,5,6 (ID 16)**

This monitoring value shows the status of the digital inputs 4-6 in slot A (standard I/O).

**V2.4.3 SLOTB RO 1,2,3 (ID 17)**

This monitoring value shows the status of the relay outputs 1-3 in slot B.

**V2.4.4 ANALOG INPUT 1 (ID 59)**

This monitoring value shows the value of the analogue input signal as a percentage of the used range.

**V2.4.5 ANALOG INPUT 2 (ID 60)**

This monitoring value shows the value of the analogue input signal as a percentage of the used range.

**V2.4.6 ANALOG INPUT 3 (ID 61)**

This monitoring value shows the value of the analogue input signal as a percentage of the used range.

**V2.4.7 ANALOG INPUT 4 (ID 62)**

This monitoring value shows the value of the analogue input signal as a percentage of the used range.

**V2.4.8 ANALOG INPUT 5 (ID 75)**

This monitoring value shows the value of the analogue input signal as a percentage of the used range.

**V2.4.9 ANALOG INPUT 6 (ID 76)**

This monitoring value shows the value of the analogue input signal as a percentage of the used range.

### **V2.4.10 SLOTA A0 1 (ID 81)**

This monitoring value shows the value of the analogue output as a percentage of the used range.

## **9.4 TEMPERATURE INPUTS**

The monitoring values related to temperature input settings are only available if a B8 or BH option board is installed.

### **V2.5.1 TEMPERATURE INPUT 1 (ID 50)**

This monitoring value shows the measured value of the temperature.  
The unit of the monitoring value is celsius degrees or fahrenheit degrees, depending on the 'C/F Selection' parameter value.



#### **NOTE!**

The list of temperature inputs is made of the first 6 available temperature inputs. The list starts from slot A and ends in slot E. If an input is available but no sensor is connected, the list shows the maximum value because the measured resistance is endless. To make the value go to its minimum value, hardwire the input.

### **V2.5.2 TEMPERATURE INPUT 2 (ID 51)**

This monitoring value shows the measured value of the temperature.  
The unit of the monitoring value is celsius degrees or fahrenheit degrees, depending on the 'C/F Selection' parameter value.

### **V2.5.3 TEMPERATURE INPUT 3 (ID 52)**

This monitoring value shows the measured value of the temperature.  
The unit of the monitoring value is celsius degrees or fahrenheit degrees, depending on the 'C/F Selection' parameter value.

### **V2.5.4 TEMPERATURE INPUT 4 (ID 69)**

This monitoring value shows the measured value of the temperature.  
The unit of the monitoring value is celsius degrees or fahrenheit degrees, depending on the 'C/F Selection' parameter value.

### **V2.5.5 TEMPERATURE INPUT 5 (ID 70)**

This monitoring value shows the measured value of the temperature.  
The unit of the monitoring value is celsius degrees or fahrenheit degrees, depending on the 'C/F Selection' parameter value.

### **V2.5.6 TEMPERATURE INPUT 6 (ID 71)**

This monitoring value shows the measured value of the temperature.  
The unit of the monitoring value is celsius degrees or fahrenheit degrees, depending on the 'C/F Selection' parameter value.



## 9.5 EXTRAS AND ADVANCED

### V2.6.1 DRIVE STATUS WORD (ID 43)

This monitoring value shows the bit-coded status of drive.

### V2.6.2 READY STATUS (ID 78)

This monitoring value shows the bit-coded data about the Ready criteria of the drive.

This data is useful for monitoring when the drive is not in the Ready state.



#### NOTE!

The values are visible as checkboxes on the graphical display. If a box is selected, the value is active.

### V2.6.3 APPLICATION STATUS WORD 1 (ID 89)

This monitoring value shows the bit-coded statuses of the application.



#### NOTE!

The values are visible as checkboxes on the graphical display. If a box is selected, the value is active.

### V2.6.4 APPLICATION STATUS WORD 2 (ID 90)

This monitoring value shows the bit-coded statuses of the application.



#### NOTE!

The values are visible as checkboxes on the graphical display. If a box is selected, the value is active.

### V2.6.5 DIN STATUS WORD 1 (ID 56)

This monitoring value shows the bit-coded status of the digital input signals.

The monitoring value is a 16 bit word, where each bit shows the status of 1 digital input.

From each slot, 6 digital inputs are read. Word 1 starts from the input 1 in slot A (bit0) and ends with input 4 in slot C (bit15).

### V2.6.6 DIN STATUS WORD 2 (ID 57)

This monitoring value shows the bit-coded status of the digital input signals.

The monitoring value is a 16 bit word, where each bit shows the status of 1 digital input.

From each slot, 6 digital inputs are read. Word 2 starts from the input 5 in slot C (bit0) and ends with input 6 in slot E (bit13).

### V2.6.7 MOTOR CURRENT 1 DECI (ID 45)

This monitoring value shows the measured current of the motor with the fixed number of decimals and that is less filtered.

This monitoring value can be used for example with fieldbus to get the correct value so that the frame size does not have an effect, or for monitoring when less filtering time is needed for the motor current.

#### **V2.6.8 FREQUENCY REFERENCE SOURCE (ID 1495)**

This monitoring value shows the momentary frequency reference source.

#### **V2.6.9 LAST ACTIVE FAULT CODE (ID 37)**

This monitoring value shows the fault code of latest activated fault that is not reset.

#### **V2.6.10 LAST ACTIVE FAULT ID (ID 95)**

This monitoring value shows the fault ID of latest activated fault that is not reset.

#### **V2.6.11 LAST ACTIVE ALARM CODE (ID 74)**

This monitoring value shows the alarm code of latest activated alarm that is not reset.

#### **V2.6.12 LAST ACTIVE ALARM ID (ID 94)**

This monitoring value shows the alarm ID of latest activated alarm that is not reset.

#### **V2.6.13 MOTOR REGULATOR STATUS (ID 77)**

This monitoring value shows the bit-coded status of the motor limit controllers.



#### **NOTE!**

The values are visible as checkboxes on the graphical display. If a box is selected, the limit controller is active.

## **9.6 TIMER FUNCTIONS**

#### **V2.7.1 TC 1, TC 2, TC 3 (ID 1441)**

This monitoring value shows the status of the time channels 1, 2 and 3.

#### **V2.7.2 INTERVAL 1 (ID 1442)**

This monitoring value shows the status of the interval function.

#### **V2.7.3 INTERVAL 2 (ID 1443)**

This monitoring value shows the status of the interval function.

#### **V2.7.4 INTERVAL 3 (ID 1444)**

This monitoring value shows the status of the interval function.

**V2.7.5 INTERVAL 4 (ID 1445)**

This monitoring value shows the status of the interval function.

**V2.7.6 INTERVAL 5 (ID 1446)**

This monitoring value shows the status of the interval function.

**V2.7.7 TIMER 1 (ID 1447)**

The monitoring value shows the remaining time on the timer if the timer is active.

**V2.7.8 TIMER 2 (ID 1448)**

The monitoring value shows the remaining time on the timer if the timer is active.

**V2.7.9 TIMER 3 (ID 1449)**

The monitoring value shows the remaining time on the timer if the timer is active.

**V2.7.10 REAL TIME CLOCK (ID 1450)**

This monitoring value shows the actual time of the real time clock in a format of hh:mm:ss.

**9.7 PID CONTROLLER****V2.8.1 PID SETPOINT (ID 20)**

This monitoring value shows the value of the PID setpoint signal in process units. You can use the parameter P3.13.1.7 to select the process unit (See *10.14.1 Basic settings*).

**V2.8.2 PID FEEDBACK (ID 21)**

This monitoring value shows the value of the PID feedback signal in process units. You can use the parameter P3.13.1.7 to select the process unit (See *10.14.1 Basic settings*).

**V2.8.3 PID ERROR (ID 22)**

This monitoring value shows the error value of the PID controller. The error value is the deviation of PID feedback from the PID setpoint in process unit. You can use the parameter P3.13.1.7 to select the process unit (See *10.14.1 Basic settings*).

**V2.8.4 PID OUTPUT (ID 23)**

This monitoring value shows the output of the PID controller as a percentage (0-100%). You can give this value to the motor control (frequency reference) or to an analogue output.

**V2.8.5 PID STATUS (ID 24)**

This monitoring value shows the state of the PID controller.

## 9.8 EXTERNAL PID CONTROLLER

### V2.9.1 EXTPID SETPOINT (ID 83)

This monitoring value shows the value of the PID setpoint signal in process units. You can use the parameter P3.14.1.10 to select the process unit (See *10.14.1 Basic settings*).

### V2.9.2 EXTPID FEEDBACK (ID 84)

This monitoring value shows the value of the PID feedback signal in process units. You can use the parameter P3.14.1.10 to select the process unit (See *10.14.1 Basic settings*).

### V2.9.3 EXTPID ERROR (ID 85)

This monitoring value shows the error value of the PID controller. The error value is the deviation of PID feedback from the PID setpoint in process unit. You can use the parameter P3.14.1.10 to select the process unit (See *10.14.1 Basic settings*).

### V2.9.4 EXTPID OUTPUT (ID 86)

This monitoring value shows the output of the PID controller as a percentage (0-100%). You can give this value to, for example, the analogue output.

### V2.9.4 EXTPID STATUS (ID 87)

This monitoring value shows the state of the PID controller.

## 9.9 MULTI-PUMP

### V2.10.1 MOTORS RUNNING (ID 30)

This monitoring value shows the actual number of motors that operate in the Multi-pump system.

### V2.10.2 AUTOCHANGE (ID 1114)

This monitoring value shows the status of the autochange requested.

## 9.10 MAINTENANCE COUNTERS

### V2.11.1 MAINTENANCE COUNTER 1 (ID 1101)

This monitoring value shows the status of the maintenance counter. The status of the maintenance counter is shown as revolutions multiplied by 1000, or in hours. For the configuration and activation of this counter, see *10.17 Maintenance counters*.

## 9.11     **FIELD BUS DATA**

### ***V2.12.1 FB CONTROL WORD (ID 874)***

This monitoring value shows the status of the fieldbus control word that the application uses in bypass mode.

Depending on the fieldbus type or profile, the data that is received from the fieldbus can be modified before it is sent to the application.

### ***V2.12.2 FB SPEED REFERENCE (ID 875)***

This monitoring value shows the fieldbus frequency reference as a percentage of minimum frequency to maximum frequency.

The speed reference information is scaled between the minimum and the maximum frequency at the moment when the application received it. You can change the minimum and the maximum frequencies after the application received the reference without an effect on the reference.

### ***V2.12.3 FB DATA IN 1 (ID 876)***

This monitoring value shows the raw value of process data in a 32-bit signed format.

### ***V2.12.4 FB DATA IN 2 (ID 877)***

This monitoring value shows the raw value of process data in a 32-bit signed format.

### ***V2.12.5 FB DATA IN 3 (ID 878)***

This monitoring value shows the raw value of process data in a 32-bit signed format.

### ***V2.12.6 FB DATA IN 4 (ID 879)***

This monitoring value shows the raw value of process data in a 32-bit signed format.

### ***V2.12.7 FB DATA IN 5 (ID 880)***

This monitoring value shows the raw value of process data in a 32-bit signed format.

### ***V2.12.8 FB DATA IN 6 (ID 881)***

This monitoring value shows the raw value of process data in a 32-bit signed format.

### ***V2.12.9 FB DATA IN 7 (ID 882)***

This monitoring value shows the raw value of process data in a 32-bit signed format.

### ***V2.12.10 FB DATA IN 8 (ID 883)***

This monitoring value shows the raw value of process data in a 32-bit signed format.

**V2.12.11 FB STATUS WORD (ID 864)**

This monitoring value shows the status of the fieldbus status word that the application uses in bypass mode.

Depending on the fieldbus type or profile, the data can be modified before it is sent to the fieldbus.

**V2.12.12 FB SPEED ACTUAL (ID 865)**

This monitoring value shows the actual speed of the drive as a percentage of minimum frequency and maximum frequency.

The value 0% indicates the minimum frequency and the value 100% indicates the maximum frequency. This monitoring value is continuously updated depending on the momentary min and max frequencies and the output frequency.

**V2.12.13 FB DATA OUT 1 (ID 866)**

This monitoring value shows the raw value of process data in a 32-bit signed format.

**V2.12.14 FB DATA OUT 2 (ID 867)**

This monitoring value shows the raw value of process data in a 32-bit signed format.

**V2.12.15 FB DATA OUT 3 (ID 868)**

This monitoring value shows the raw value of process data in a 32-bit signed format.

**V2.12.16 FB DATA OUT 4 (ID 869)**

This monitoring value shows the raw value of process data in a 32-bit signed format.

**V2.12.17 FB DATA OUT 5 (ID 870)**

This monitoring value shows the raw value of process data in a 32-bit signed format.

**V2.12.18 FB DATA OUT 6 (ID 871)**

This monitoring value shows the raw value of process data in a 32-bit signed format.

**V2.12.19 FB DATA OUT 7 (ID 872)**

This monitoring value shows the raw value of process data in a 32-bit signed format.

**V2.12.20 FB DATA OUT 8 (ID 873)**

This monitoring value shows the raw value of process data in a 32-bit signed format.

## 10 PARAMETER DESCRIPTIONS

In this chapter, you can find data on the most special parameters of the application. For most parameters of the Vacon 100 application, a basic description is sufficient. You can find these basic descriptions in the parameter tables of Chapter 5 *Parameters menu*. If other data is necessary, your distributor will help you.

### ***P1.2 APPLICATION (ID212)***

Use this parameter to select the application configuration for the drive. The applications include preset application configurations, that is, sets of predefined parameters. The selection of the application makes the commissioning of the drive easy and reduces the manual work with the parameters.

When the value of this parameter changes, a group of parameters get their preset values. You can change the value of this parameter when you make the start up or the commissioning of the drive.

If you use the control panel to change this parameter, an application wizard starts and helps you to set the basic parameters related to the application. The wizard does not start, if you use the PC tool to change this parameter. You can find data about the application wizards in Chapter 2 *Wizards*.

These applications are available:

- 0 = Standard
- 1 = Local/Remote
- 2 = Multi-step speed
- 3 = PID control
- 4 = Multi-purpose
- 5 = Motor potentiometer



#### **NOTE!**

When you change the application, the contents of the Quick Setup menu change.

### **10.1 TREND CURVE**

#### ***P2.2.2 SAMPLING INTERVAL (ID 2368)***

Use this parameter to set the sampling interval.

#### ***P2.2.3 CHANNEL 1 MIN (ID 2369)***

This parameter is used in scaling by default. Adjustments can be necessary.

#### ***P2.2.4 CHANNEL 1 MAX (ID 2370)***

This parameter is used in scaling by default. Adjustments can be necessary.

**P2.2.5 CHANNEL 2 MIN (ID 2371)**

This parameter is used in scaling by default. Adjustments can be necessary.

**P2.2.6 CHANNEL 2 MAX (ID 2372)**

This parameter is used in scaling by default. Adjustments can be necessary.

**P2.2.7 AUTOSCALE (ID 2373)**

Use this parameter to set autoscaling on or off. If autoscaling is enabled, the signal is automatically scaled between the minimum and maximum values.

**10.2 MOTOR SETTINGS****10.2.1 MOTOR NAMEPLATE PARAMETERS****P3.1.1.1 MOTOR NOMINAL VOLTAGE (ID 110)**

Find the value  $U_n$  on the nameplate of the motor. Find out whether the motor connection is Delta or Star.

**P3.1.1.2 MOTOR NOMINAL FREQUENCY (ID 111)**

Find the value  $f_n$  on the nameplate of the motor. When this parameter changes, parameters P3.1.4.2 Field Weakening Point Frequency and P3.1.4.3 Voltage at Field Weakening Point start automatically. The 2 parameters have different values for each motor type. See the tables in *P3.1.2.2 Motor Type (ID 650)*.

**P3.1.1.3 MOTOR NOMINAL SPEED (ID 112)**

Find the value  $n_n$  on the nameplate of the motor.

**P3.1.1.4 MOTOR NOMINAL CURRENT (ID 113)**

Find the value  $I_n$  on the nameplate of the motor.

**P3.1.1.5 MOTOR COS PHI (ID 120)**

Find the value on the nameplate of the motor.

**P3.1.1.6 MOTOR NOMINAL POWER (ID 116)**

Find the value  $I_n$  on the nameplate of the motor.



## 10.2.2 MOTOR CONTROL PARAMETERS

### P3.1.2.1 CONTROL MODE (ID 600)

Use this parameter to set the AC drive control mode.

Selection number	Selection name	Description
0	Frequency control (open loop)	The frequency reference of the drive is set to the output frequency without slip compensation. The actual speed of the motor is specified by the motor load.
1	Speed control (sensorless control)	The frequency reference of the drive is set to the motor speed reference. The motor load does not have an effect on the motor speed. There is slip compensation.
2	Torque control (open loop)	The motor torque is controlled. The motor produces torque in the set speed limits to achieve torque reference. P3.3.2.7 (Torque Control Frequency Limit) controls the motor speed limit.

### P3.1.2.2 MOTOR TYPE (ID 650)

Use this parameter to set the type of motor in your process.

Selection number	Selection name	Description
0	Induction motor (IM)	Make this selection if you use an induction motor.
1	Permanent Magnet Motor (PM)	Make this selection if you use a permanent magnet motor.
2	Reluctance Motor	Make this selection if you use a reluctance motor.

When you change the value of parameter P3.1.2.2 Motor Type, the values of parameters P3.1.4.2 Field Weakening Point Frequency and P3.1.4.3 Voltage at Field Weakening Point change automatically, as the table below shows. The 2 parameters have different values for each motor type.

Parameter	Induction motor (IM)	Permanent magnet motor (PM)
P3.1.4.2 (Field Weakening Point Frequency)	Motor nominal frequency	Internally calculated
P3.1.4.3 (Voltage at Field Weakening Point)	100.0%	Internally calculated

### P3.1.2.3 SWITCHING FREQUENCY (ID 601)

Use this parameter to set the switching frequency of the AC drive.

If you increase the switching frequency, the capacity of the AC drive reduces. To reduce capacitive currents in the motor cable, when the cable is long, we recommend that you use a low switching frequency. To reduce the motor noise, use a high switching frequency.

### **P3.1.2.4 IDENTIFICATION (ID 631)**

Use this parameter to find the parameter values that are optimal for the operation of the drive.

The identification run calculates or measures the motor parameters that are necessary for a good control of the motor and speed.

The identification run helps you to adjust the motor-specific and the drive-specific parameters. It is a tool for the commissioning and the servicing of the drive.



#### **NOTE!**

Before you do the identification run, you have to set the motor nameplate parameters.

Selection number	Selection name	Description
0	No action	No identification requested.
1	Identification at standstill	The drive operates without speed when you do the identification run for the motor parameters. The motor receives current and voltage, but the frequency is zero. The U/f ratio and start magnetisation parameters are identified.
2	Identification with motor rotating	The drive operates with speed when you do the identification run for the motor parameters. The U/f ratio, the magnetisation current and start magnetisation parameters are identified.  To get accurate results, do this identification run with no load on the motor shaft.

To activate the Identification function, set the parameter P3.1.2.4 and give a start command. You have to give the start command in 20 s. If there is no start command in that time, the identification run does not start. The parameter P3.1.2.4 is reset to the default value and an identification alarm shows.

To stop the identification run before it is completed, give a stop command. This resets the parameter to the default value. If the identification run is not completed, an identification alarm shows.



#### **NOTE!**

To start the drive after the identification, a new start command is necessary.

### **P3.1.2.5 MAGNETIZING CURRENT (ID 612)**

Use this parameter to set the magnetising current of the motor.

The magnetising current (no-load current) of the motor identifies the values of the U/f parameters if they are given before the identification run. If the value is set to 0, the magnetising current is calculated internally.

### **P3.1.2.6 MOTOR SWITCH (ID 653)**

Use this parameter to enable the Motor Switch function.

You can use the Motor Switch function, if the cable that connects the motor and the drive has a motor switch. The operation of the motor switch makes sure that the motor is isolated from the voltage source and does not start during the servicing.

To activate the function, set the parameter P3.1.2.6 to the value *Enabled*. The drive stops automatically when the motor switch is opened, and the drive starts automatically when the motor switch is closed. The drive does not trip when you use the Motor switch function.

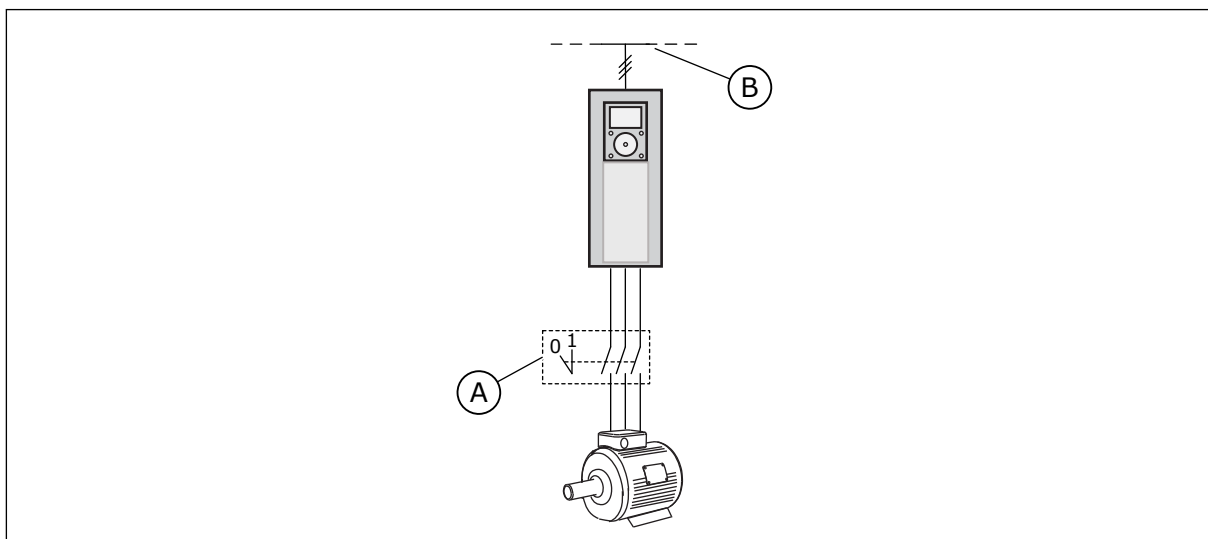

Fig. 20: The motor switch between the drive and the motor

A. The motor switch

B. Mains

### **P3.1.2.7 LOAD DROOPING (ID 620)**

Use this parameter to enable the Load Drooping function.

The Load drooping function enables a speed drop as a function of load. You can use this function when a balanced load is necessary for mechanically connected motors. This is called static drooping. You can also use the function when a dynamic drooping is necessary because the load changes. In static drooping, the Load Drooping Time is set to 0, so that the drooping cannot decay. In dynamic drooping, the Load Drooping Time is set. The load is momentarily drooped with energy from the system inertia. This decreases the current torque spikes when the load changes suddenly.

If the motor has a nominal frequency of 50 Hz, the motor is loaded with the nominal load (100% of the torque), and Load Drooping is set to 10%, the output frequency is let to decrease 5 Hz from the frequency reference.

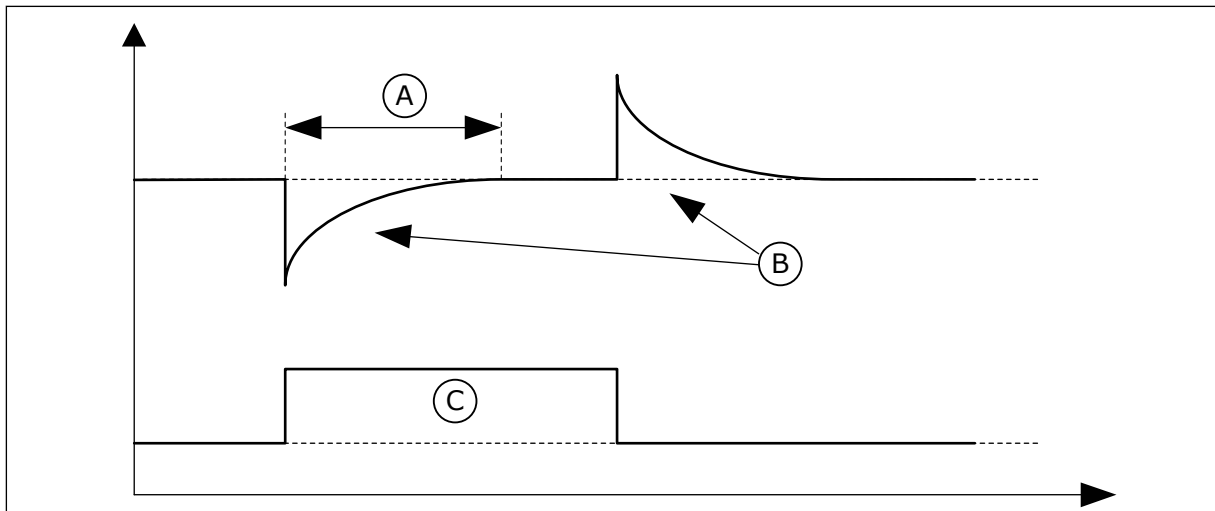

Fig. 21: The Load drooping function

- A. Load Drooping Time (ID 656)
- B. Output Frequency
- C. Torque

**P3.1.2.8 LOAD DROOPING TIME (ID 656)**

Use this parameter to set the drooping time of the motor. Use load drooping to get a dynamic speed drooping when the load changes. This parameter gives the time during which the speed is restored 63% of the change.

**P3.1.2.9 LOAD DROOPING MODE (ID 1534)**

Use this parameter to set the load drooping mode.

Selection number	Selection name	Description
0	Normal	The load drooping factor is constant through the frequency range.
1	Linear removal	The load drooping is removed linearly from the nominal frequency to zero frequency.

**P3.1.2.10 OVERVOLTAGE CONTROL (ID 607)**

Use this parameter to set the overvoltage controller out of operation.

The function is necessary when

- the supply voltage changes, for example, between -15% and +10%, and
- the process you control does not have the tolerance for the changes that the undervoltage controller and the overvoltage controller make to the output frequency of the drive.

The overvoltage controller increases the output frequency of the drive

- to keep the DC link voltage in the permitted limits, and
- to make sure that the drive does not trip because of an overvoltage fault.

**NOTE!**

The drive can trip when the overvoltage and undervoltage controllers are disabled.

**P3.1.2.11 UNDERVOLTAGE CONTROL (ID 608)**

Use this parameter to set the undervoltage controller out of operation.

The function is necessary when

- the supply voltage changes, for example, between -15% and +10%, and
- the process you control does not have the tolerance for the changes that the undervoltage controller and the overvoltage controller make to the output frequency of the drive.

The undervoltage controller decreases the output frequency of the drive

- to get energy from the motor to keep the DC link voltage at a minimum level when the voltage is near the lowest permitted limit, and
- to make sure that the drive does not trip because of an undervoltage fault.

**NOTE!**

The drive can trip when the overvoltage and undervoltage controllers are disabled.

**P3.1.2.12 ENERGY OPTIMIZATION (ID 666)**

Use this parameter to enable the Energy Optimization function.

To save energy and to lower the motor noise, the drive searches for the minimum motor current. You can use this function for example in fan and pump processes. Do not use the function with fast PID controlled processes.

**P3.1.2.13 STATOR VOLTAGE ADJUST (ID 659)**

Use this parameter to adjust the stator voltage in permanent magnet motors.

**NOTE!**

The identification run sets a value for this parameter automatically. We recommend that you make the identification run, if it is possible. You can make the identification run with the parameter P3.1.2.4.

It is possible to use this parameter only when the parameter P3.1.2.2 Motor Type has the value *PM motor*. If you set *induction motor* as the motor type, the value is automatically set to 100%, and you cannot change the value.

When you change the value of P3.1.2.2 (Motor type) to *PM Motor*, the parameters P3.1.4.2 (Field Weakening Point Frequency) and P3.1.4.3 (Voltage at Field Weakening Point) will increase automatically to be equal with output voltage of the drive. The set U/f ratio does not change. This is done to prevent the operation of the PM motor in the field weakening area. The nominal voltage of the PM motor is much lower than the full output voltage of the drive.

The nominal voltage of the PM motor agrees to the back-EMF voltage of the motor at nominal frequency. But in a different motor manufacturer, it can be equal to, for example, the stator voltage at nominal load.

Stator Voltage Adjust helps you to adjust the U/f curve of the drive near the back-EMF curve. It is not necessary to change the values of many U/f curve parameters.

The parameter P3.1.2.13 gives the output voltage of the drive in percentage of the nominal voltage of the motor at the nominal frequency of the motor. Adjust the U/f curve of the drive above the back-EMF curve of the motor. The motor current increases the more the U/f curve is different from the back-EMF curve.

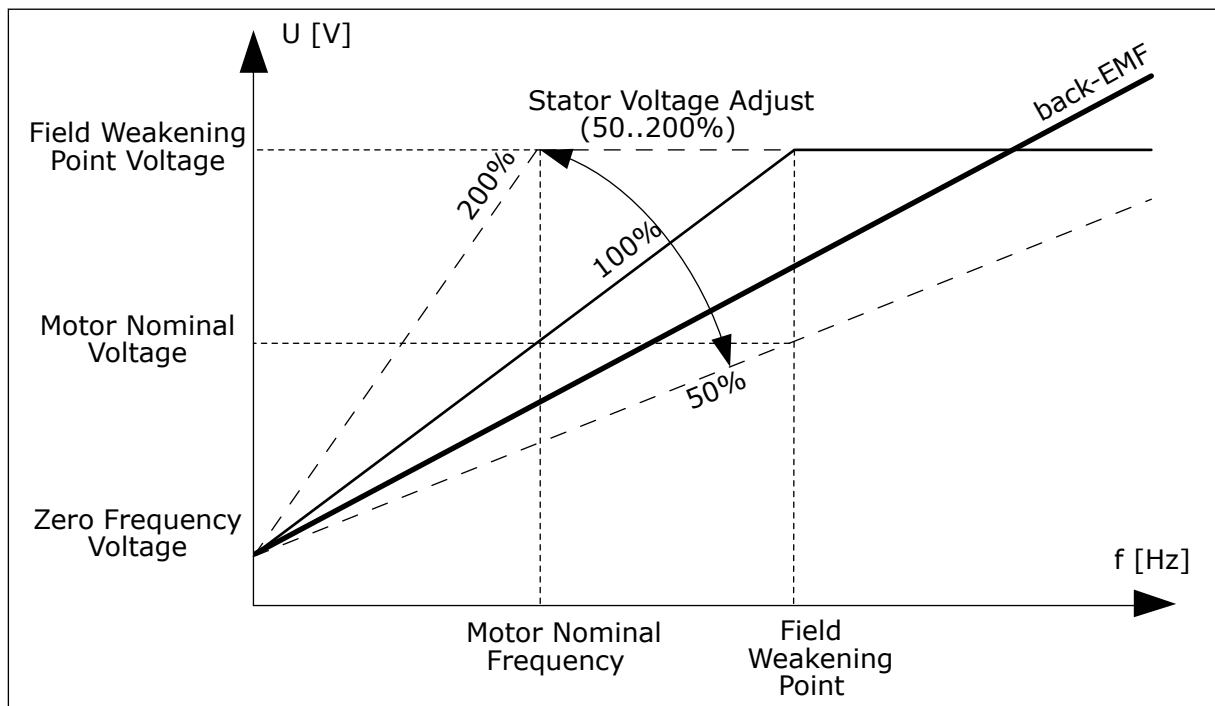

Fig. 22: The stator voltage adjustment

### P3.1.2.14 OVERMODULATION (ID 1515)

Use this parameter to disable the overmodulation of the AC drive. Overmodulation maximises the output voltage of the drive, but increases the motor current harmonics.

## 10.2.3 MOTOR LIMITS

### P3.1.3.1 MOTOR CURRENT LIMIT (ID 107)

Use this parameter to set the maximum motor current from the AC drive. The range of values for the parameter is different for each frame size of the drive.

When the current limit is active, the drive output frequency decreases.



#### NOTE!

The Motor Current Limit is not an overcurrent trip limit.

**P3.1.3.2 MOTOR TORQUE LIMIT (ID 1287)**

Use this parameter to set the maximum torque limit of the motoring side.  
The range of values for the parameter is different for each frame size of the drive.

**P3.1.3.3 GENERATOR TORQUE LIMIT (ID 1288)**

Use this parameter to set the maximum torque limit of the generating side.  
The range of values for the parameter is different for each frame size of the drive.

**P3.1.3.4 MOTOR POWER LIMIT (ID 1289)**

Use this parameter to set the maximum power limit of the motoring side.  
The range of values for the parameter is different for each frame size of the drive.

**P3.1.3.5 GENERATOR POWER LIMIT (ID 1290)**

Use this parameter to set the maximum power limit of the generating side.  
The range of values for the parameter is different for each frame size of the drive.

**10.2.4 OPEN LOOP PARAMETERS****P3.1.4.1 U/F RATIO (ID 108)**

Use this parameter to set the type of the U/f curve between zero frequency and the field weakening point.

Selection number	Selection name	Description
0	Linear	The voltage of the motor changes linearly as a function of the output frequency. The voltage changes from the value of P3.1.4.6 (Zero Frequency Voltage) to the value of P3.1.4.3 (Voltage at Field Weakening Point) at a frequency set in P3.1.4.2 (Field Weakening Point Frequency). Use this default setting if a different setting is not necessary.
1	Squared	The voltage of the motor changes from the value of P3.1.4.6 (Zero Frequency Voltage) to the value of P3.1.4.2 (Field Weakening Point Frequency) at a squared curve. The motor operates undermagnetised below the field weakening point and produces less torque. You can use the squared U/f ratio in applications where the torque demand is in relation to the square of the speed, for example in centrifugal fans and pumps.
2	Programmable	It is possible to program the U/f curve with 3 different points: the zero frequency voltage (P1), the midpoint voltage/frequency (P2), and the field weakening point (P3). You can use the programmable U/f curve at low frequencies if it is necessary to have more torque. You can find the optimal settings automatically with an identification run (P3.1.2.4).

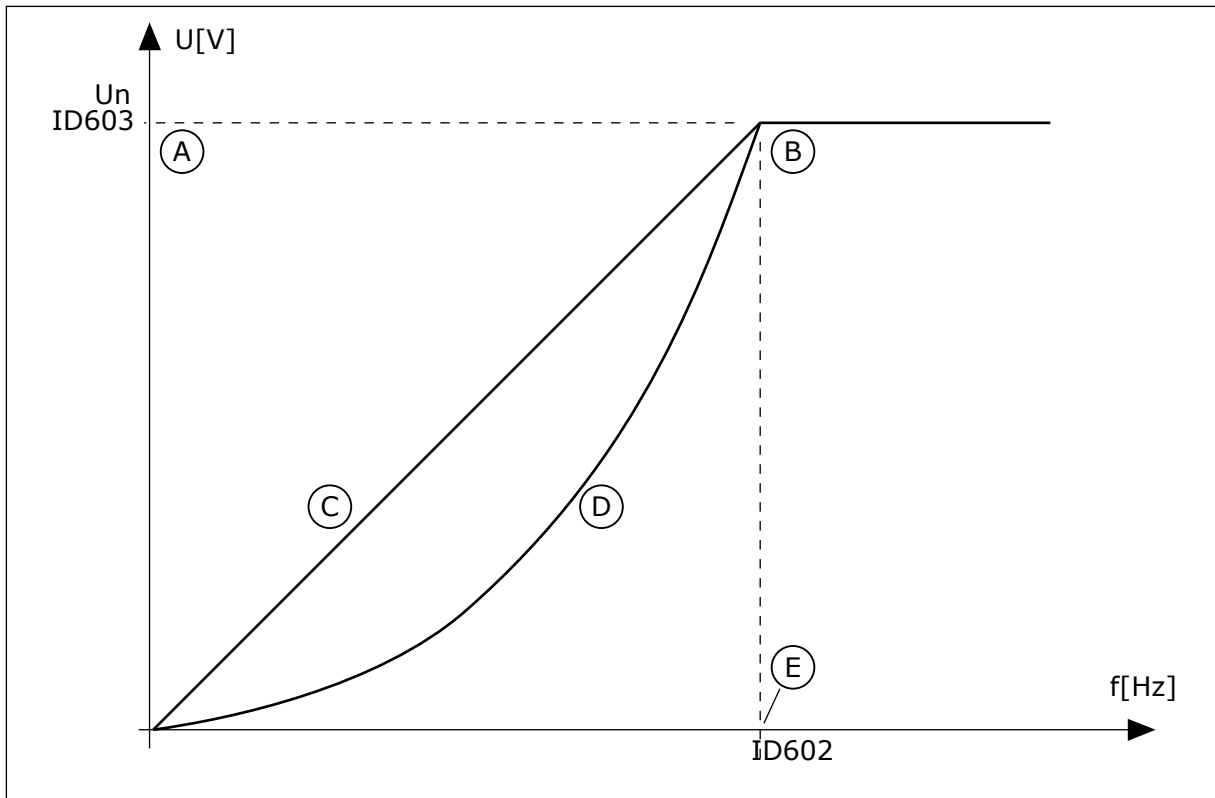

Fig. 23: Linear and squared change of the motor voltage

- A. Default: Nominal voltage of the motor
- B. Field weakening point
- C. Linear
- D. Squared
- E. Default: Nominal frequency of the motor

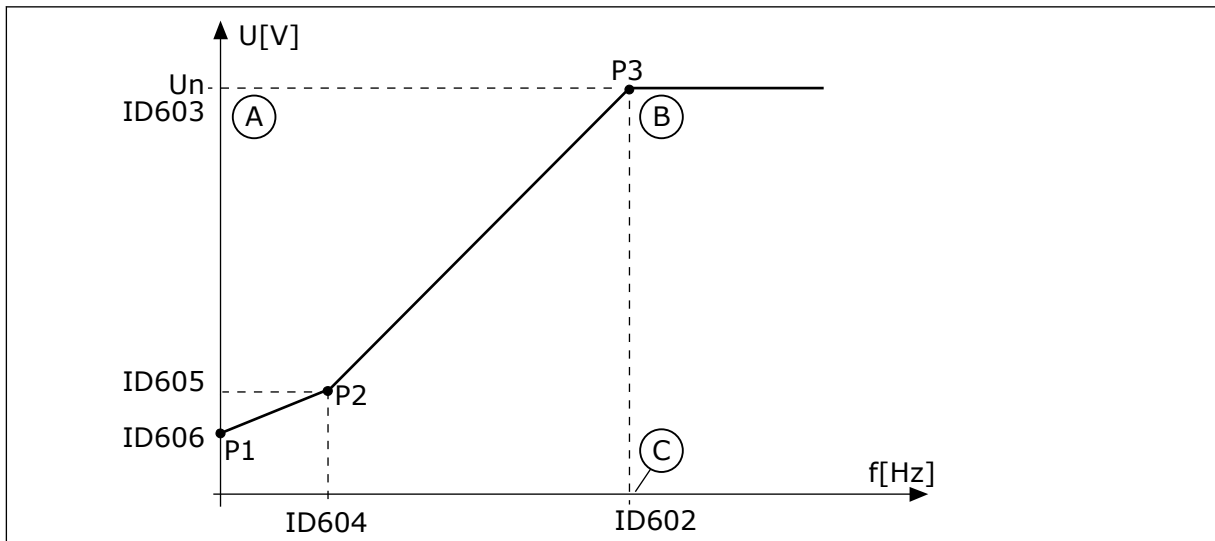

Fig. 24: The programmable U/f curve

- A. Default: Nominal voltage of the motor
- B. Field weakening point
- C. Default: Nominal frequency of the motor

When the parameter Motor Type has the value *PM motor (Permanent Magnet Motor)*, this parameter is automatically set to the value *Linear*.



When the parameter Motor Type has the value *Induction Motor*, and when this parameter is changed, these parameters are set to their default values.

- P3.1.4.2 Field Weakening Point Frequency
- P3.1.4.3 Voltage at Field Weakening Point
- P3.1.4.4 U/f Midpoint Frequency
- P3.1.4.5 U/f Midpoint Voltage
- P3.1.4.6 Zero Frequency Voltage

#### **P3.1.4.2 FIELD WEAKENING POINT FREQUENCY (ID 602)**

Use this parameter to set the output frequency at which the output voltage reaches the field weakening point voltage.

#### **P3.1.4.3 VOLTAGE AT FIELD WEAKENING POINT (ID 603)**

Use this parameter to set the voltage at the field weakening point as a percentage of the motor nominal voltage.

Above the frequency at the field weakening point, the output voltage stays at the set maximum value. Below the frequency at the field weakening point, the U/f curve parameters control the output voltage. See the U/f parameters P3.1.4.1, P3.1.4.4 and P3.1.4.5.

When you set the parameters P3.1.1.1 (Motor nominal voltage) and P3.1.1.2 (Motor nominal frequency), the parameters P3.1.4.2 and P3.1.4.3 automatically receive related values. To have different values for P3.1.4.2 and P3.1.4.3, change these parameters only after you set the parameters P3.1.1.1 and P3.1.1.2.

#### **P3.1.4.4 U/F MIDPOINT FREQUENCY (ID 604)**

Use this parameter to set the middle point frequency of the U/f curve.



#### **NOTE!**

This parameter gives the middle point frequency of the curve if the value of P3.1.4.1 is *programmable*.

#### **P3.1.4.5 U/F MIDPOINT VOLTAGE (ID 605)**

Use this parameter to set the middle point voltage of the U/f curve.



#### **NOTE!**

This parameter gives the middle point voltage of the curve if the value of P3.1.4.1 is *programmable*.

#### **P3.1.4.6 ZERO FREQUENCY VOLTAGE (ID 606)**

Use this parameter to set the zero frequency voltage of the U/f curve. The default value for the parameter is different for each unit size.

#### **P3.1.4.7 FLYING START OPTIONS (ID 1590)**

Use this parameter to set the flying start options. The parameter Flying Start Options has a checkbox selection of values.

The bits can receive these values.

- Search the shaft frequency only from the same direction as the frequency reference
- Disable the AC scanning
- Use the frequency reference for an initial guess
- Disable the DC pulses
- Flux build with current control

The bit B0 controls the search direction. When you set the bit to 0, the shaft frequency is searched in 2 directions, the positive and the negative. When you set the bit to 1, the shaft frequency is searched only in the frequency reference direction. This prevents the shaft movements for the other direction.

The bit B1 controls the AC scanning that premagnetises the motor. In the AC scanning, the system sweeps the frequency from the maximum towards zero frequency. The AC scanning stops when an adaptation to the shaft frequency occurs. To disable the AC scanning, set the bit B1 to 1. If the value of Motor Type is permanent magnet motor, the AC scanning is disabled automatically.

With the bit B5 you can disable the DC pulses. The primary function of the DC pulses is to premagnetise the motor and examine the rotation of the motor. If the DC pulses and the AC scanning are enabled, the slip frequency tells which procedure is applied. If the slip frequency is less than 2 Hz, or the motor type is PM motor, the DC pulses are disabled automatically.

#### ***P3.1.4.8 FLYING START SCAN CURRENT (ID 1610)***

Use this parameter to set the flying start scan current as a percentage of the motor nominal current.

#### ***P3.1.4.9 AUTOMATIC TORQUE BOOST (ID 109)***

Use this parameter with a process that has a high starting torque because of friction.

The voltage to the motor changes in relation to the necessary torque. This makes the motor give more torque at the start and when the motor operates at low frequencies.

The torque boost has an effect with a linear U/f curve. You can get the best result when you have done the identification run and activated the programmable U/f curve.

#### ***P3.1.4.10 TORQUE BOOST MOTOR GAIN (ID 667)***

Use this parameter to set the scaling factor for the motoring side IR-compensation when the torque boost is used.

#### ***P3.1.4.11 TORQUE BOOST GENERATOR GAIN (ID 665)***

Use this parameter to set the scaling factor for the generating side IR-compensation when the torque boost is used.

### **10.2.5 I/F START FUNCTION**

When you have a PM motor, use the I/f Start function to start the motor with constant current control. You can receive the best effect with a high power motor. With a high power motor, the resistance is low and it is not easy to change the U/f curve.

The I/f Start function can also give a sufficient torque for the motor at startup.

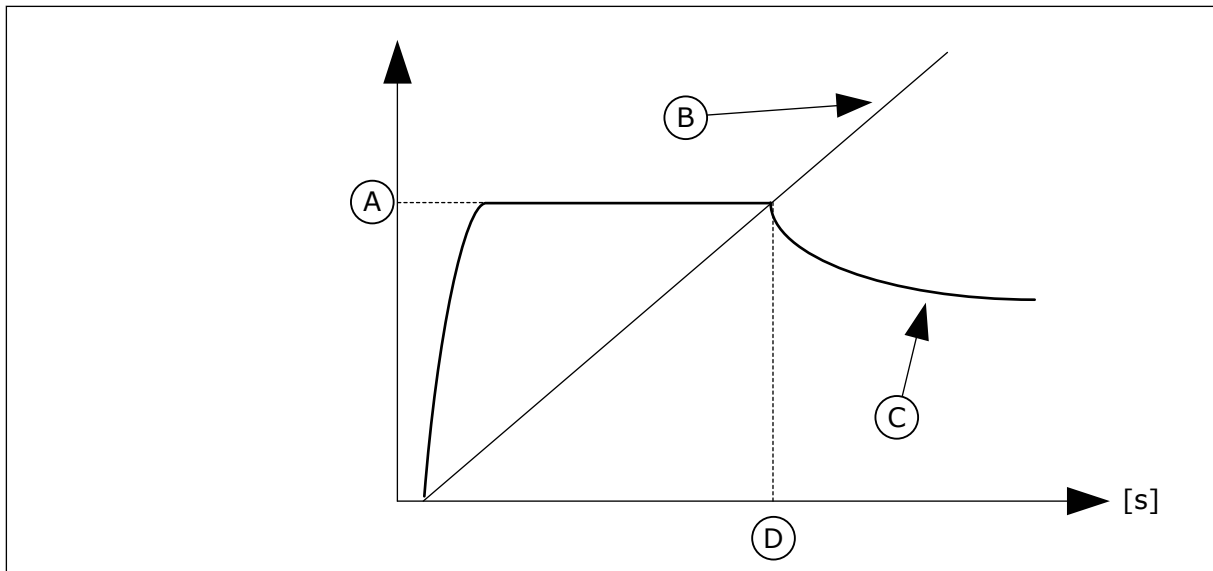

Fig. 25: The I/f start parameters

- |                      |                        |
|----------------------|------------------------|
| A. I/f Start Current | C. Motor Current       |
| B. Output Frequency  | D. I/f Start Frequency |

#### **P3.1.4.12.1 I/F START (ID 534)**

Use this parameter to enable the I/f Start function.

When you activate the I/f Start function, the drive starts to operate in the current control mode. A constant current is led to the motor until the output frequency increases above the level that is set in P3.1.4.12.2. When the output frequency increases above I/f Start Frequency level, the operation mode changes back to the normal U/f control mode.

#### **P3.1.4.12.2 I/F START FREQUENCY (ID 535)**

Use this parameter to set the output frequency limit below which the set I/f start current is fed to motor.

When the output frequency of the drive is below the limit of this parameter, I/f Start function activates. When the output frequency is more than the limit, the drive operation mode changes back to the normal U/f control mode.

#### **P3.1.4.12.3 I/F START CURRENT (ID 536)**

Use this parameter to set the current that is used when the I/f Start function is enabled.

### 10.2.6 TORQUE STABILATOR FUNCTION

#### **P3.1.4.13.1 TORQUE STABILATOR GAIN (ID 1412)**

Use this parameter to set the gain of the torque stabilator in an open loop control operation.

#### **P3.1.4.13.2 TORQUE STABILATOR GAIN AT FIELD WEAKENING POINT (ID 1414)**

Use this parameter to set the gain of the torque stabilator at field weakening point in an open loop control operation.

The torque stabiliser stabilises the possible oscillations in the estimated torque.

Two gains are used. TorqStabGainFWP is a constant gain at all the output frequencies. TorqStabGain changes linearly between the zero frequency and the field weakening point frequency. The full gain is at 0 Hz and the gain is zero at the field weakening point. The figure shows the gains as a function of output frequency.

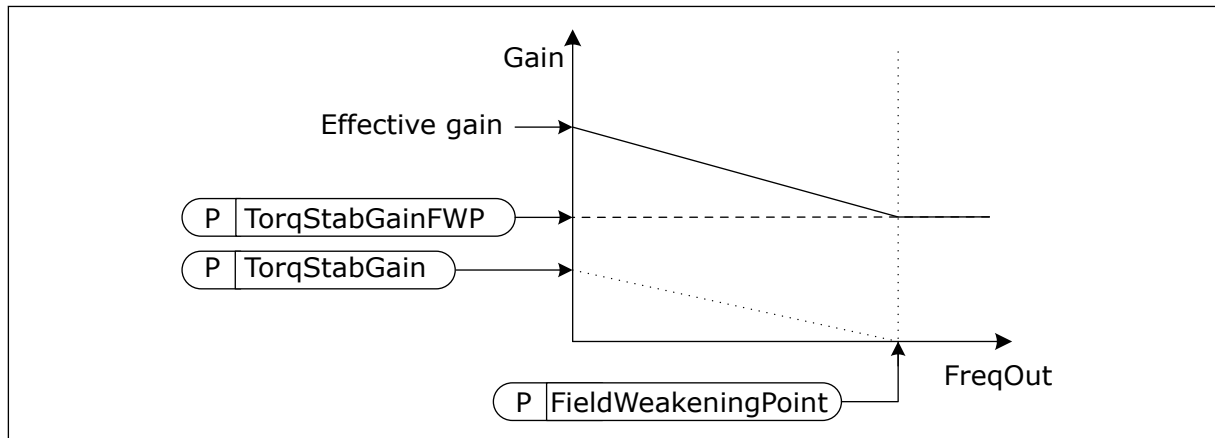

Fig. 26: The torque stabilator gain

### **P3.1.4.13.3 TORQUE STABILATOR DAMPING TIME CONSTANT (ID 1413)**

Use this parameter to set the damping time constant of the torque stabiliser.

### **P3.1.4.13.4 TORQUE STABILATOR DAMPING TIME CONSTANT FOR PMM (ID 1735)**

Use this parameter to set the damping time constant of the torque stabiliser for PM motors.

## **10.2.7 SENSORLESS CONTROL**

### **P3.1.6.1 SENSORLESS CONTROL (ID 1724)**

Use this parameter to enable the Sensorless Control function.

## **10.3 START/STOP SETUP**

You must give the start and stop commands differently in each control place.

### **REMOTE CONTROL PLACE (I/O A)**

Use the parameters P3.5.1.1 (Control signal 1 A), P3.5.1.2 (Control signal 2 A) and P3.5.1.3 (Control signal 3 A) to make a selection of digital inputs. These digital inputs control the start, stop and reverse commands. Then make a selection of a logic for these inputs with P3.2.6 I/O A Logic.

### **REMOTE CONTROL PLACE (I/O B)**

Use the parameters P3.5.1.4 (Control signal 1 B), P3.5.1.5 (Control signal 2 B) and P3.5.1.6 (Control signal 3 B) to make a selection of digital inputs. These digital inputs control the

start, stop and reverse commands. Then make a selection of a logic for these inputs with P3.2.7 I/O B Logic.

### LOCAL CONTROL PLACE (KEYPAD)

The start and stop commands come from the keypad buttons. The direction of the rotation is set with parameter P3.3.1.9 Keypad direction.

### REMOTE CONTROL PLACE (FIELDBUS)

Start, stop and reverse commands come from the fieldbus.

#### **P3.2.1 REMOTE CONTROL PLACE (ID 172)**

Use this parameter to select the remote control place (start/stop).

Use this parameter to change back to remote control from Vacon Live, for example if the control panel is broken.

#### **P3.2.2 LOCAL/REMOTE (ID 211)**

Use this parameter to switch between the local and remote control places.

Local control place is always keypad control. The remote control place can be I/O or Fieldbus, depending on the 'Remote Control Place' parameter value.

#### **P3.2.3 KEYPAD STOP BUTTON (ID 114)**

Use this parameter to enable the keypad stop button.

When this function is enabled, a press of keypad stop button always stops the drive (regardless of the control place). When this function is disabled, a press of keypad stop button stops the drive in local control only.

Selection number	Selection name	Description
0	Yes	The keypad stop button is always enabled.
1	No	Limited function of the keypad stop button.

#### **P3.2.4 START FUNCTION (ID 505)**

Use this parameter to select the type of the start function.

Selection number	Selection name	Description
0	Ramping	The drive drive accelerates from 0 frequency to frequency reference.
1	Flying start	The drive detects the actual speed of the motor and accelerates from that speed to frequency reference.

**P3.2.5 STOP FUNCTION (ID 506)**

Use this parameter to select the type of the stop function.

Selection number	Selection name	Description
0	Coasting	The motor stops on its inertia. When the stop command is given, the control by the drive stops and the current from the drive goes to 0.
1	Ramp	After the stop command, the speed of the motor is decreased to zero speed according to the deceleration parameters.

**NOTE!**

Ramp stop cannot be guaranteed in all situations. If ramp stop is selected and the net voltage changes over 20 %, the voltage estimation fails. In such case, ramp stop is not possible.

**P3.2.6 I/O A START/STOP LOGIC (ID 300)**

Use this parameter to control the start and stop of the drive with the digital signals. The selections can include the word 'edge' to help you prevent an accidental start.

**An accidental start can occur, for example, in these conditions**

- When you connect the power.
- When the power is connected again after a power cut.
- After you reset a fault.
- After Run Enable stops the drive.
- When you change the control place to I/O control.

Before you can start the motor, you must open the Start/Stop contact.

In all the examples of the next pages, the stop mode is coasting. CS = Control signal.

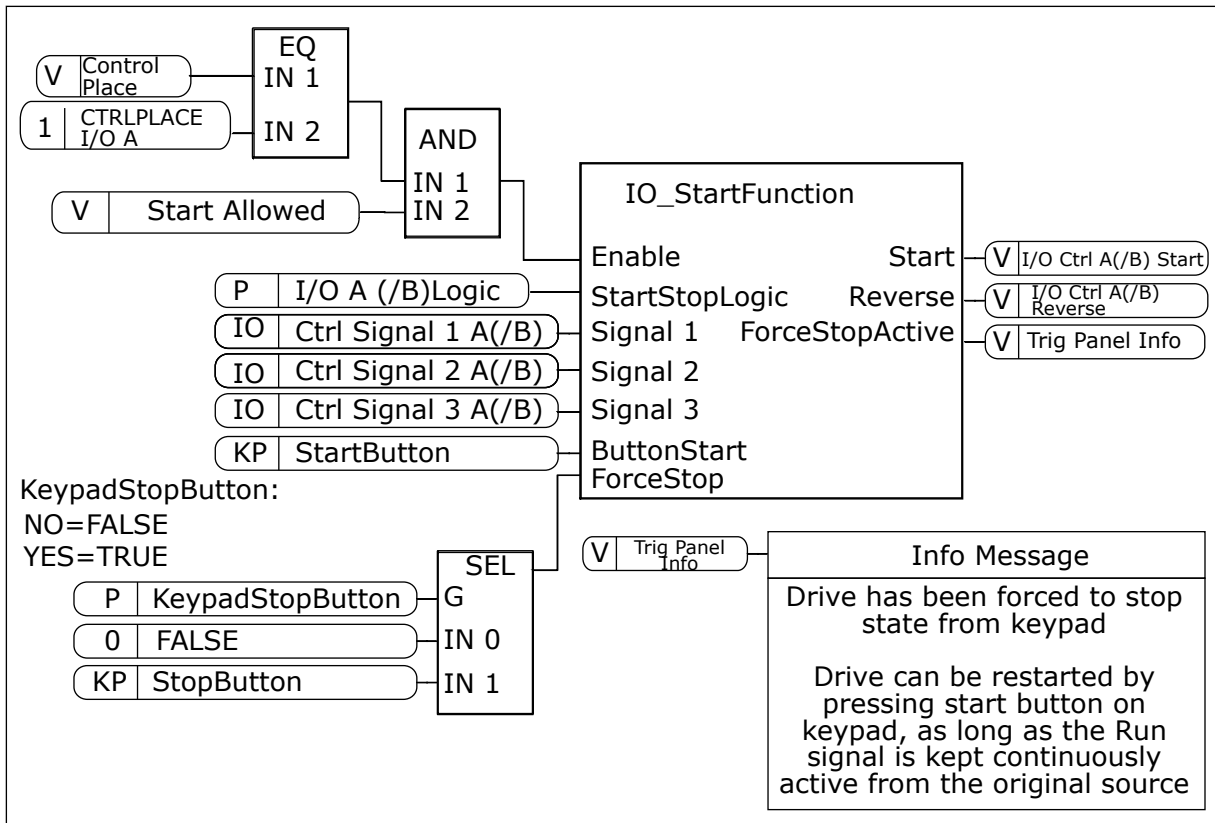

Fig. 27: The block diagram of the I/O A Start/stop logic

Selection number	Selection name	Description
0	CS1 = Forward CS2 = Backward	The functions activate when the contacts are closed.

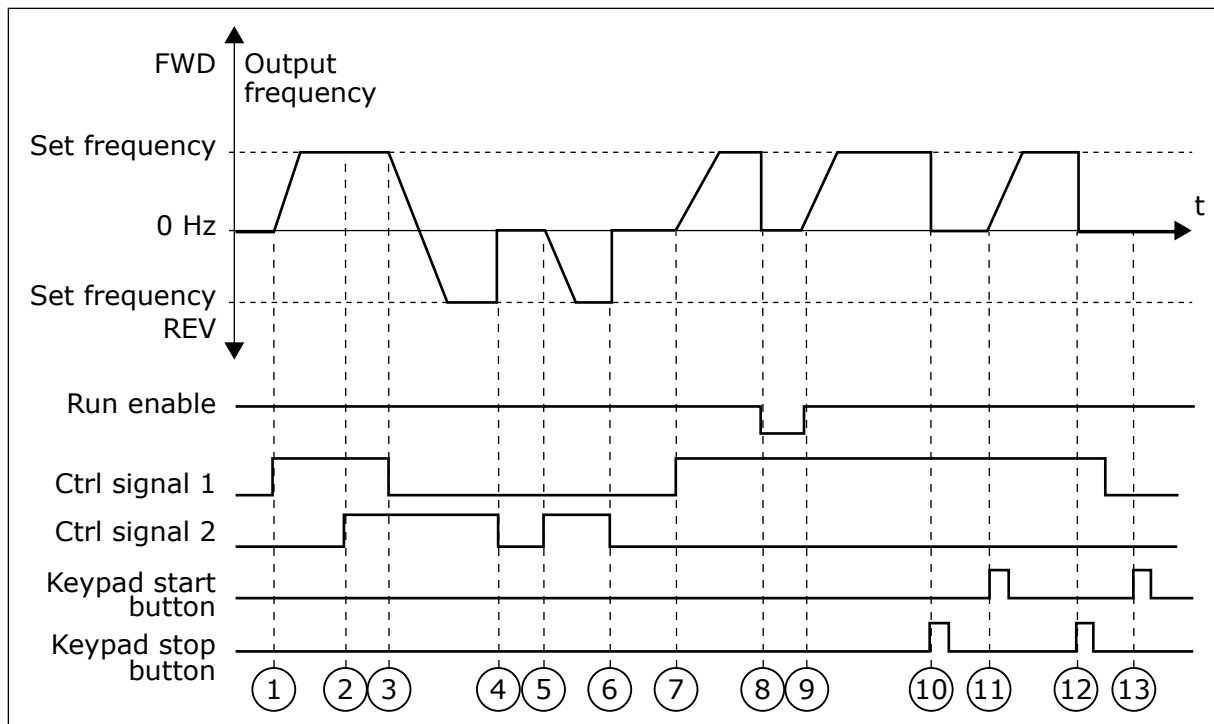

Fig. 28: I/O A Start/stop logic = 0

1. Control signal (CS) 1 activates and causes the output frequency to increase. The motor operates forward.
2. CS2 activates, but it does not have an effect on the output frequency, because the direction that is set first has the highest priority.
3. CS1 becomes inactive and causes the direction to start to change (FWD to REV), because CS2 is still active.
4. CS2 becomes inactive and the frequency that is fed to the motor goes to 0.
5. CS2 activates again and causes the motor to accelerate (REV) to the set frequency.
6. CS2 becomes inactive and the frequency fed to the motor drops to 0.
7. CS1 activates and the motor accelerates (FWD) to the set frequency
8. The Run enable signal is set to OPEN, which causes the frequency to go to 0. Configure the Run enable signal with parameter P3.5.1.15.
9. The Run enable signal is set to CLOSED, which causes the frequency to increase to the set frequency, because CS1 is still active.
10. The STOP button on the keypad is pushed, and the frequency that is fed to the motor goes to 0. (This signal only works if the value of P3.2.3 Keypad Stop Button is Yes.)
11. The drive starts because the START button on the keypad was pushed.
12. The STOP button on the keypad is pushed again to stop the drive.
13. The attempt to start the drive with the START button is not successful, because CS1 is inactive.



Selection number	Selection name	Description
1	CS1 = Forward (edge) CS2 = Inverted stop CS3 = Backward (edge)	For a 3-wire control (pulse control)

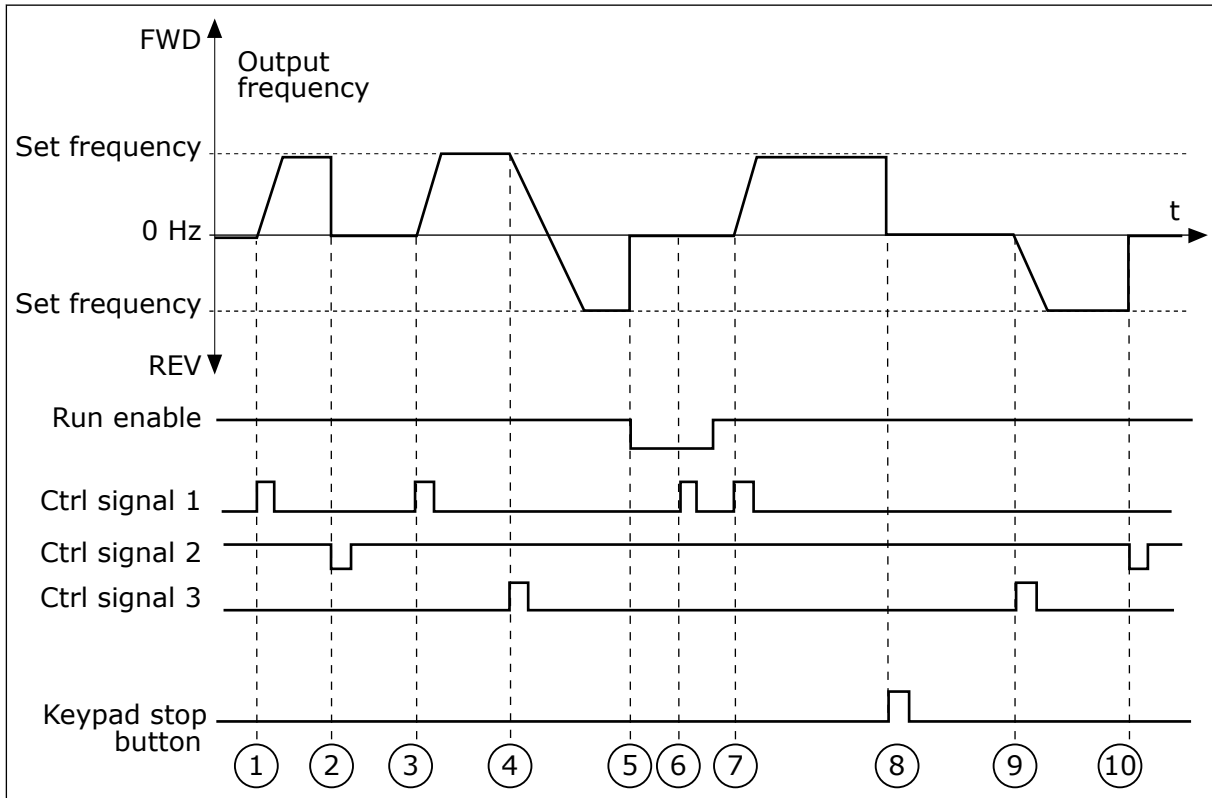

Fig. 29: I/O A Start/stop logic = 1

- Control signal (CS) 1 activates and causes the output frequency to increase. The motor operates forward.
- CS2 becomes inactive and causes the frequency to go to 0.
- CS1 activates and causes the output frequency to increase again. The motor operates forward.
- CS3 activates and causes the direction to start to change (FWD to REV).
- The Run enable signal is set to OPEN, which causes the frequency to go to 0. Configure the Run enable signal with parameter 3.5.1.15.
- The start attempt with CS1 is not successful, because the Run enable signal is still OPEN.
- CS1 activates and the motor accelerates (FWD) to the set frequency, because the Run enable signal was set to CLOSED.
- The STOP button on the keypad is pushed, and the frequency that is fed to the motor goes to 0. (This signal only works if the value of P3.2.3 Keypad Stop Button is Yes.)
- CS3 activates and causes the motor to start and to operate in the reverse direction.
- CS2 becomes inactive and causes the frequency to go to 0.

Selection number	Selection name	Description
2	CS1 = Forward (edge) CS2 = Backward (edge)	Use this function to prevent an accidental start. Before you can start the motor again, you must open the start/stop contact.

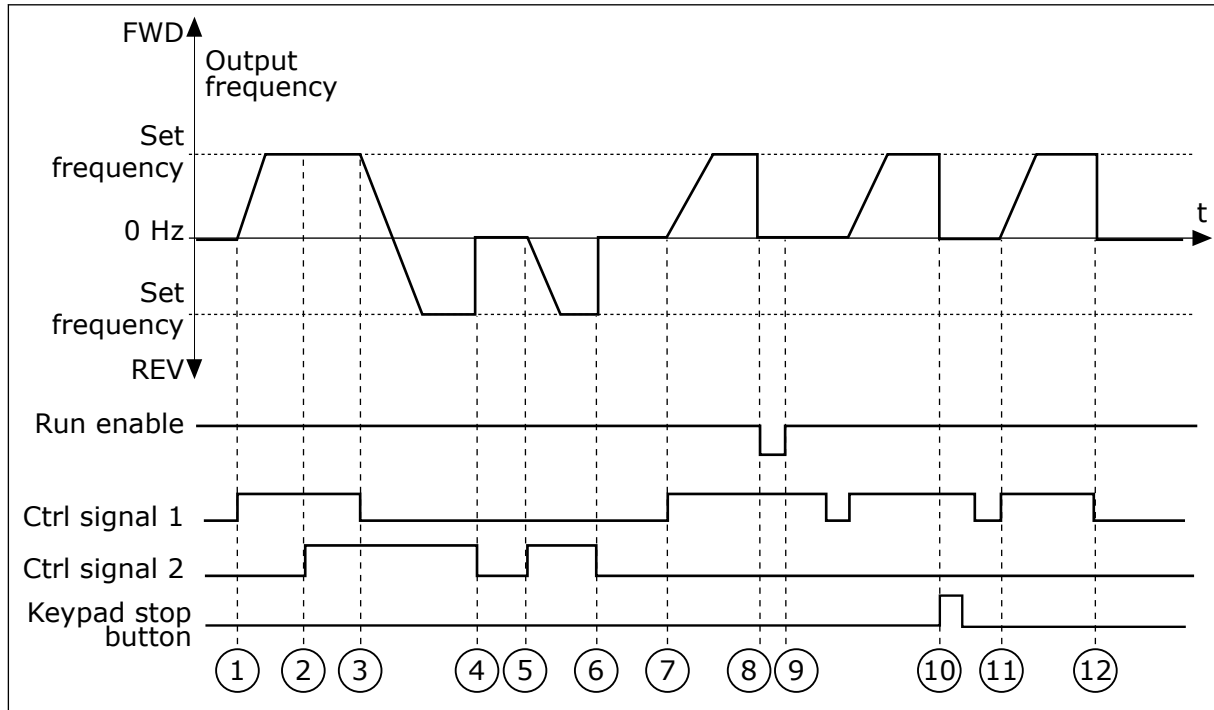

Fig. 30: I/O A Start/stop logic = 2

- Control signal (CS) 1 activates and causes the output frequency to increase. The motor operates forward.
- CS2 activates, but it does not have an effect on the output frequency, because the direction that is set first has the highest priority.
- CS1 becomes inactive and causes the direction to start to change (FWD to REV), because CS2 is still active.
- CS2 becomes inactive and the frequency that is fed to the motor goes to 0.
- CS2 activates again and causes the motor to accelerate (REV) to the set frequency.
- CS2 becomes inactive and the frequency that is fed to the motor goes to 0.
- CS1 activates and the motor accelerates (FWD) to the set frequency.
- The Run enable signal is set to OPEN, which causes the frequency to go to 0. Configure the Run enable signal with parameter P3.5.1.15.
- The Run enable signal is set to CLOSED, which does not have an effect, because a rising edge is necessary for the start, even if CS1 is active.
- The STOP button on the keypad is pushed and the frequency that is fed to the motor goes to 0. (This signal only works if the value of P3.2.3 Keypad Stop Button is Yes.)
- CS1 is opened and closed again, which causes the motor to start.
- CS1 becomes inactive and the frequency that is fed to the motor goes to 0.

Selection number	Selection name	Description
3	CS1 = Start CS2 = Reverse	

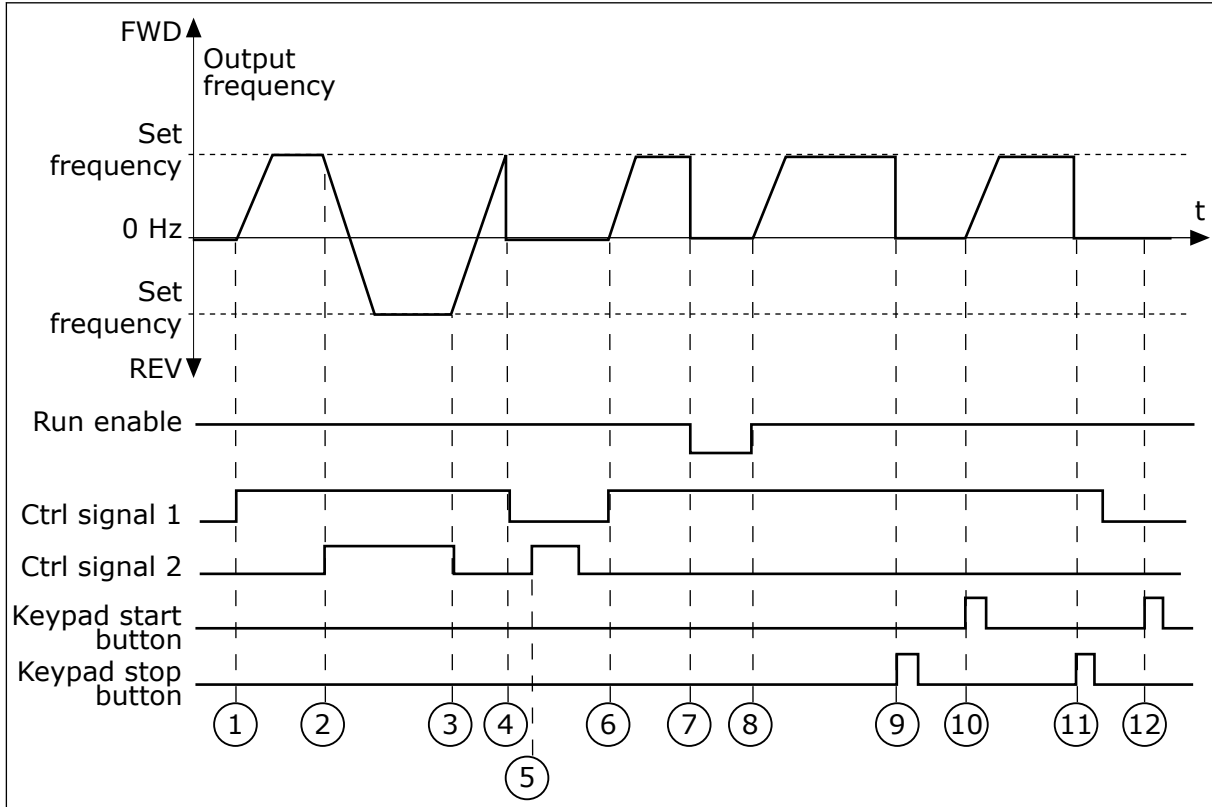

Fig. 31: I/O A Start/stop logic = 3

- Control signal (CS) 1 activates and causes the output frequency to increase. The motor operates forward.
- CS2 activates and causes the direction to start to change (FWD to REV).
- CS2 becomes inactive, which causes the direction to start to change (REV to FWD), because CS1 is still active.
- CS1 becomes inactive and the frequency goes to 0.
- CS2 activates, but the motor does not start because CS1 is inactive.
- CS1 activates and causes the output frequency to increase again. The motor operates forward because CS2 is inactive.
- The Run enable signal is set to OPEN, which causes the frequency to go to 0. Configure the Run enable signal with parameter P3.5.1.15.
- The Run enable signal is set to CLOSED, which causes the frequency to increase to the set frequency, because CS1 is still active.
- The STOP button on the keypad is pushed and the frequency that is fed to the motor goes to 0. (This signal only works if the value of P3.2.3 Keypad Stop Button is Yes.)
- The drive starts because the START button on the keypad was pushed.
- The drive is stopped again with the STOP button on the keypad.

12. The attempt to start the drive with the START button is not successful, because CS1 is inactive.

Selection number	Selection name	Description
4	CS1 = Start (edge) CS2 = Reverse	Use this function to prevent an accidental start. Before you can start the motor again, you must open the start/stop contact.

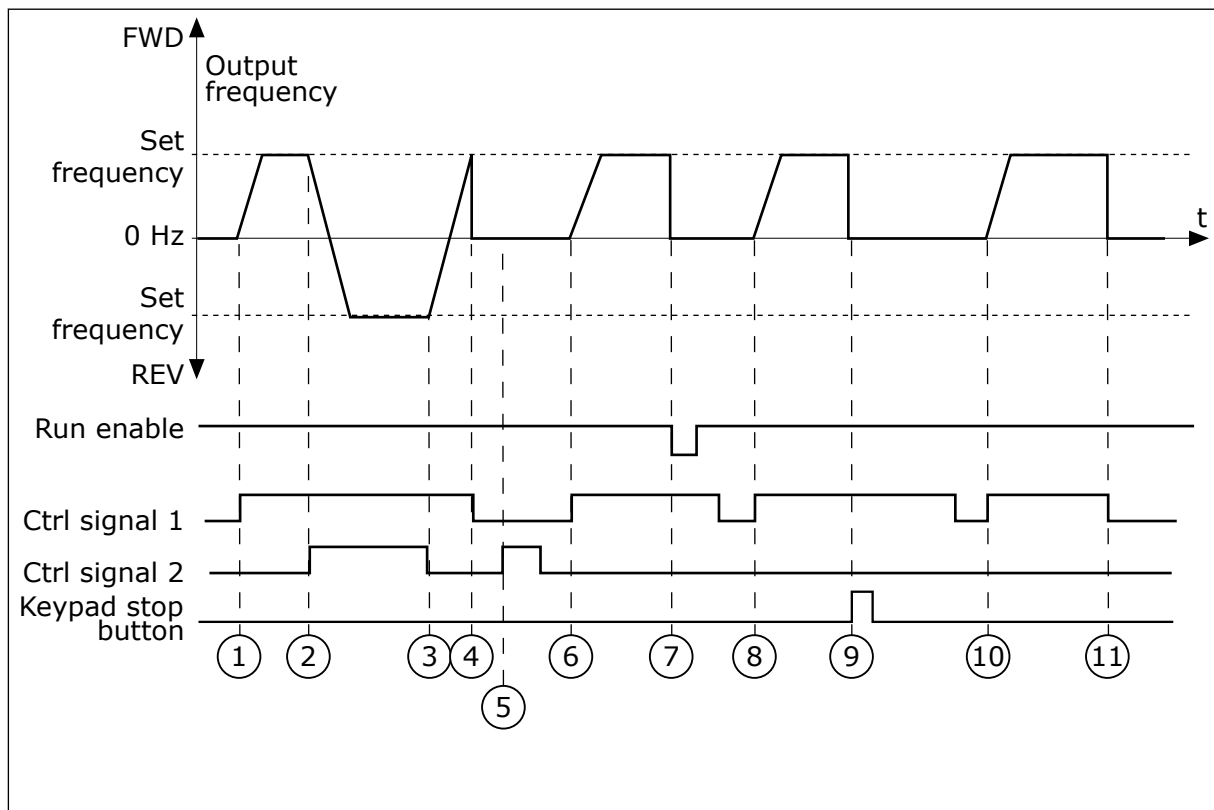

Fig. 32: I/O A Start/stop logic = 4

- Control signal (CS) 1 activates and causes the output frequency to increase. The motor operates forward because CS2 is inactive.
- CS2 activates, which causes the direction to start to change (FWD to REV).
- CS2 becomes inactive, which causes the direction to start to change (REV to FWD), because CS1 is still active.
- CS1 becomes inactive and the frequency goes to 0.
- CS2 activates, but the motor does not start because CS1 is inactive.
- CS1 activates and causes the output frequency to increase again. The motor operates forward, because CS2 is inactive.
- The Run enable signal is set to OPEN, which causes the frequency to go to 0. Configure the Run enable signal with parameter P3.5.1.15.
- Before the drive can start, you must open and close CS1 again.

9. The STOP button on the keypad is pushed and the frequency that is fed to the motor goes to 0. (This signal only works if the value of P3.2.3 Keypad Stop Button is Yes.)
10. Before the drive can start, you must open and close CS1 again.
11. CS1 becomes inactive and the frequency goes to 0.

### **P3.2.7 I/O B START/STOP LOGIC (ID 363)**

Use this parameter to control the start and stop of the drive with the digital signals. The selections can include the word 'edge' to help you prevent an accidental start. See P3.2.6 for more information.

### **P3.2.8 FIELDBUS START LOGIC (ID 889)**

Use this parameter to set the fieldbus start logic. The selections can include the word 'edge' to help you prevent an accidental start.

Selection number	Selection name	Description
0	A rising edge is necessary	
1	State	

### **P3.2.9 START DELAY (ID 524)**

Use this parameter to set the delay between the start command and the actual start of the drive.

### **P3.2.10 REMOTE TO LOCAL FUNCTION (ID 181)**

Use this parameter to set the selection of copy settings when you go from Remote to Local (keypad) control.

Selection number	Selection name	Description
0	Keep Run	
1	Keep Run & Reference	
2	Stop	

## 10.4 REFERENCES

### 10.4.1 FREQUENCY REFERENCE

It is possible to program the source of the frequency reference in all the control places, except the PC tool. If you use your PC, it always takes the frequency reference from the PC tool.

#### REMOTE CONTROL PLACE (I/O A)

To set the source of the frequency reference for I/O A, use the parameter P3.3.1.5 .

#### REMOTE CONTROL PLACE (I/O B)

To set the source of the frequency reference for I/O B, use the parameter P3.3.1.6.

#### LOCAL CONTROL PLACE (KEYPAD)

If you use the default value *keypad* for the parameter P3.3.1.7, the reference that you set for P3.3.1.8 Keypad Reference applies.

#### REMOTE CONTROL PLACE (FIELDBUS)

If you keep the default value *fieldbus* for the parameter P3.3.1.10, the frequency reference comes from fieldbus.

#### **P3.3.1.1 MINIMUM FREQUENCY REFERENCE (ID 101)**

Use this parameter to set the minimum frequency reference.

#### **P3.3.1.2 MAXIMUM FREQUENCY REFERENCE (ID 102)**

Use this parameter to set the maximum frequency reference.

#### **P3.3.1.3 POSITIVE FREQUENCY REFERENCE LIMIT (ID 1285)**

Use this parameter to set the final frequency reference limit for the positive direction.

#### **P3.3.1.4 NEGATIVE FREQUENCY REFERENCE LIMIT (ID 1286)**

Use this parameter to set the final frequency reference limit for the negative direction.  
Use this parameter for example to prevent the motor from running in the reverse direction.

#### **P3.3.1.5 I/O CONTROL REFERENCE A SELECTION (ID 117)**

Use this parameter to select the reference source when the control place is I/O A.  
The application that you set with parameter 1.2 gives the default value.

#### **P3.3.1.6 I/O CONTROL REFERENCE B SELECTION (ID 131)**

Use this parameter to select the reference source when the control place is I/O B.  
See P3.3.1.5 for more information. You can force the I/O B control place to be active only with a digital input (P3.5.1.7).

### P3.3.1.7 KEYPAD CONTROL REFERENCE SELECTION (ID 121)

Use this parameter to select the reference source when the control place is keypad.

### P3.3.1.8 KEYPAD REFERENCE (ID 184)

Use this parameter to adjust the frequency reference on the keypad.

### P3.3.1.9 KEYPAD DIRECTION (ID 123)

Use this parameter to set the rotation direction of the motor when the control place is keypad.

### P3.3.1.10 FIELDBUS CONTROL REFERENCE SELECTION (ID 122)

Use this parameter to select the reference source when the control place is Fieldbus. The selection of the application with parameter P1.2 Application gives the default value. See the default values in Chapter 12 Appendix 1.

## 10.4.2 TORQUE REFERENCE

When the parameter P3.1.2.1 (Control Mode) is set to *Torque control open loop*, the motor torque is controlled. The motor speed changes to agree with the actual load on the motor shaft. P3.3.2.7 (Torque Control Frequency Limit) controls the motor speed limit.

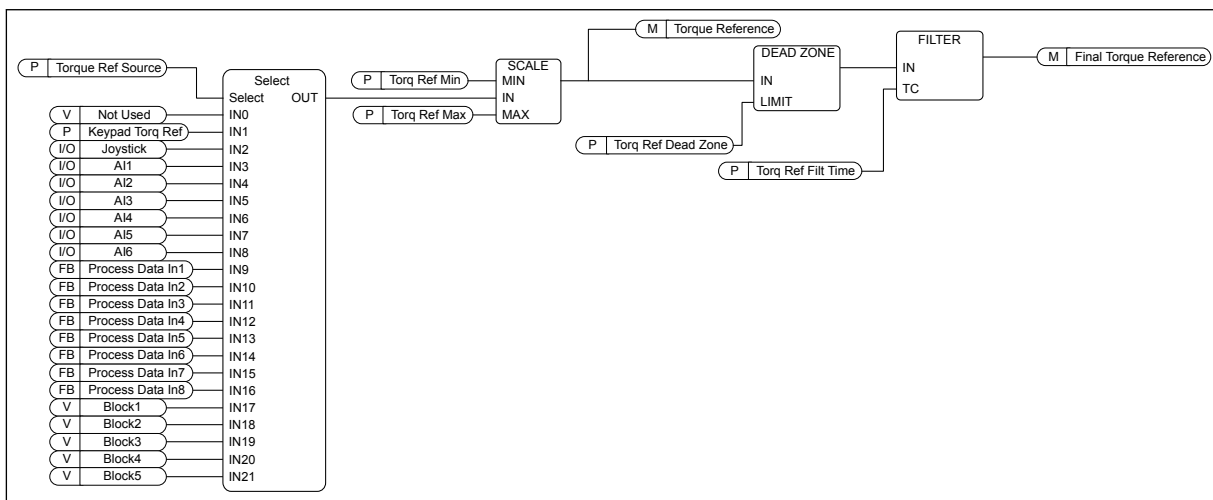

Fig. 33: The torque reference chain diagram

### P3.3.2.1 TORQUE REFERENCE SELECTION (ID 641)

Use this parameter to select the torque reference.

The torque reference is scaled between the values of P3.3.2.2. and P3.3.2.3.

If you use a fieldbus protocol where the torque reference can be given in Nm units, you must set *ProcessDataIn1* as the value to this parameter.

### P3.3.2.2 TORQUE MINIMUM REFERENCE (ID 643)

Use this parameter to set the minimum torque reference.

This parameter defines the minimum torque reference of the positive and negative values.

**NOTE!**

This value is not applied when torque reference source is Joystick.

**P3.3.2.3 TORQUE MAXIMUM REFERENCE (ID 642)**

Use this parameter to set the maximum torque reference of the positive and negative values.

These parameters define the scaling of selected torque reference signal. For instance, the analogue input signal is scaled between the Torque Reference Minimum and the Torque Reference Maximum.

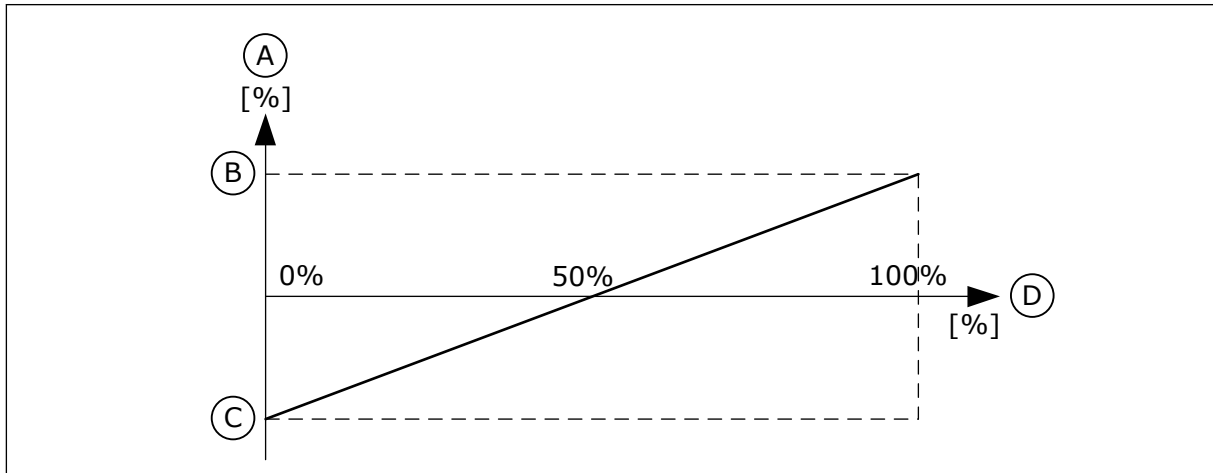

Fig. 34: Scaling of the torque reference signal

- |                             |                             |
|-----------------------------|-----------------------------|
| A. Torque reference         | C. Torque reference minimum |
| B. Torque reference maximum | D. Analogue input signal    |

**P3.3.2.4 TORQUE REFERENCE FILTER TIME (ID 1244)**

Use this parameter to set the filtering time for the final torque reference.

**P3.3.2.5 TORQUE REFERENCE DEAD ZONE (ID 1246)**

Use this parameter to set the torque reference dead zone.

To ignore the small values around 0 of the torque reference, set this value to be bigger than 0. When the reference signal is between 0 and  $0 \pm$  the value of this parameter, the torque reference is set to 0.

**P3.3.2.6 KEYPAD TORQUE REFERENCE (ID 1439)**

Use this parameter to set the keypad torque reference.

This parameter is used when P3.3.2.1. is set to 1. The value of this parameter is limited between P3.3.2.3. and P3.3.2.2.

**P3.3.2.7 TORQUE CONTROL FREQUENCY LIMIT (ID 1278)**

Use this parameter to select the output frequency limit mode for the torque control.

In the torque control mode, the drive output frequency is always limited between MinFreqReference and MaxFreqReference (P3.3.1.1 and P3.3.1.2).



You can also make the selection of 2 other modes with this parameter.

Selection 0 = *Pos/Neg Freq Limits*, that is, the positive/negative frequency limits.

The frequency is limited between Positive Frequency Reference Limit (P3.3.1.3) and Negative Frequency Reference Limit (P3.3.1.4) [if these parameters are set lower than the value of P3.3.1.2 Maximum Frequency].

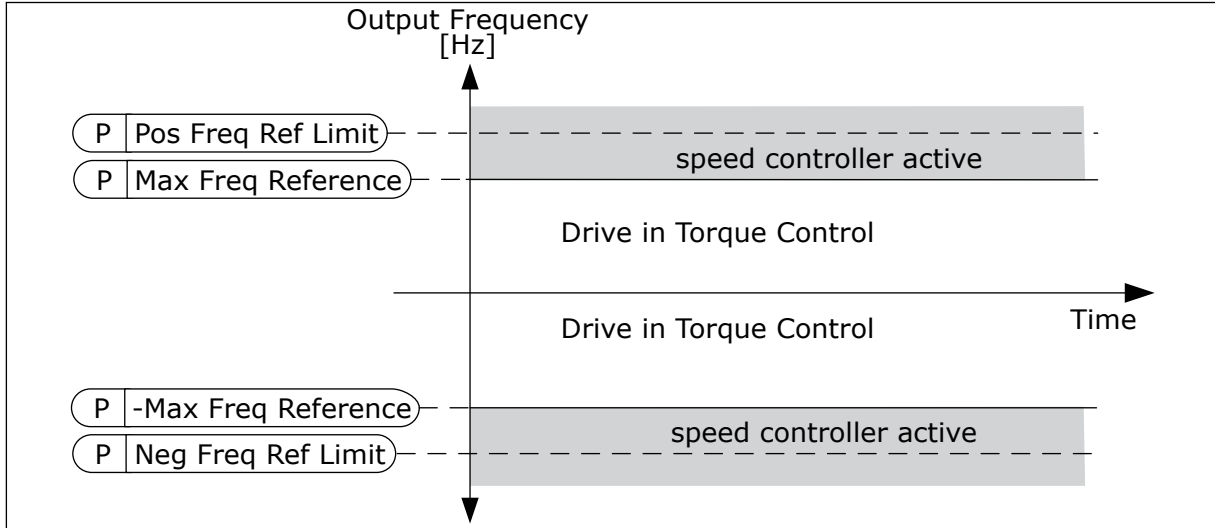

Fig. 35: Torque control frequency limit, selection 0

Selection 1 = *Freq Reference*, that is, the frequency reference for both directions.

The frequency is limited by the actual frequency reference (after the ramp generator) for both directions. That is, the output frequency increases within the set ramp time until the actual torque is equal to the referenced torque.

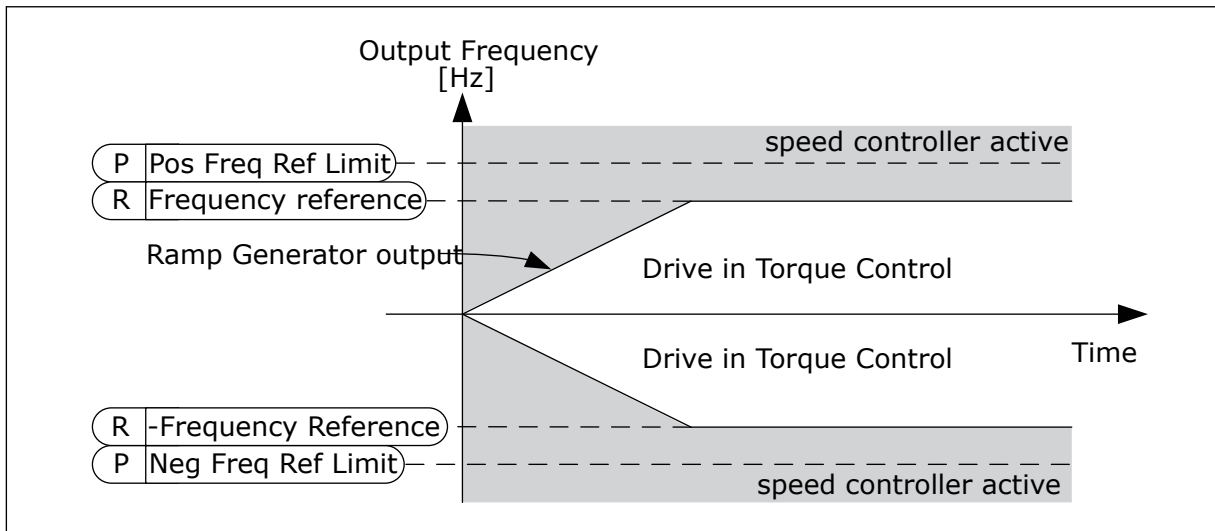

Fig. 36: Torque control frequency limit, selection 1

### 10.4.3 TORQUE CONTROL OPEN LOOP

#### **P3.3.2.8.1 OPEN LOOP TORQUE CONTROL MINIMUM FREQUENCY (ID 636)**

Use this parameter to set the output frequency limit below which the drive operates in the frequency control mode.

#### **P3.3.2.8.2 OPEN LOOP TORQUE CONTROL P GAIN (ID 639)**

Use this parameter to set the P gain for the torque controller in the open loop control mode. The P Gain value 1.0 causes a 1 Hz change in the output frequency when the torque error is 1% of the motor nominal torque.

#### **P3.3.2.8.3 OPEN LOOP TORQUE CONTROL I GAIN (ID 640)**

Use this parameter to set the I gain for the torque controller in the open loop control mode. The I Gain value 1.0 causes the integration to reach 1.0 Hz in 1 second when the torque error is 1% of the motor nominal torque.

### 10.4.4 PRESET FREQUENCIES

You can use the Preset frequencies function in processes where more than 1 fixed frequency reference is necessary. There are 8 preset frequency references available. You can make the selection of a preset frequency reference with the digital input signals P3.3.3.10, P3.3.3.11, and P3.3.3.12.

#### **P3.3.3.1 PRESET FREQUENCY MODE (ID 182)**

Use this parameter to set the logic of the digital input preset frequencies. With this parameter, you can set the logic which one of the preset frequencies is selected into use. There is a selection of 2 different logics. The number of preset speed digital inputs that are active defines the preset frequency.

Selection number	Selection name	Description
0	Binary coded	The mix of the inputs is binary coded. The different sets of active digital inputs determine the preset frequency. See more data in <i>Table 119 The selection of preset frequencies when P3.3.3.1 = Binary coded.</i>
1	Number (of inputs used)	The number of active inputs tells which preset frequency is used: 1, 2 or 3.

#### **P3.3.3.2 PRESET FREQUENCY 0 (ID 180)**

Use this parameter to set the preset frequency reference when the preset frequencies function is used. Select the preset frequencies with the digital input signals.

**P3.3.3.3 PRESET FREQUENCY 1 (ID 105)**

Use this parameter to set the preset frequency reference when the preset frequencies function is used.

Select the preset frequencies with the digital input signals.

**P3.3.3.4 PRESET FREQUENCY 2 (ID 106)**

Use this parameter to set the preset frequency reference when the preset frequencies function is used.

Select the preset frequencies with the digital input signals.

**P3.3.3.5 PRESET FREQUENCY 3 (ID 126)**

Use this parameter to set the preset frequency reference when the preset frequencies function is used.

Select the preset frequencies with the digital input signals.

**P3.3.3.6 PRESET FREQUENCY 4 (ID 127)**

Use this parameter to set the preset frequency reference when the preset frequencies function is used.

Select the preset frequencies with the digital input signals.

**P3.3.3.7 PRESET FREQUENCY 5 (ID 128)**

Use this parameter to set the preset frequency reference when the preset frequencies function is used.

Select the preset frequencies with the digital input signals.

**P3.3.3.8 PRESET FREQUENCY 6 (ID 129)**

Use this parameter to set the preset frequency reference when the preset frequencies function is used.

Select the preset frequencies with the digital input signals.

**P3.3.3.9 PRESET FREQUENCY 7 (ID 130)**

Use this parameter to set the preset frequency reference when the preset frequencies function is used.

Select the preset frequencies with the digital input signals.

**VALUE 0 SELECTED FOR PARAMETER P3.3.3.1:**

To set Preset Frequency 0 as reference, set the value 0 *Preset Frequency 0* for P3.3.1.5 (I/O Control Reference A Selection).

To make a selection of a preset frequency between 1 and 7, give digital inputs to P3.3.3.10 (Preset Frequency Selection 0), P3.3.3.11 (Preset Frequency Selection 1), and/or P3.3.3.12 (Preset Frequency Selection 2). The different sets of active digital inputs determine the preset frequency. You can find more data in the table below. The values of the preset frequencies stay automatically between the minimum and maximum frequencies (P3.3.1.1 and P3.3.1.2).

Necessary step	Activated frequency
Make a selection of the value 0 for parameter P3.3.1.5.	Preset frequency 0

**Table 119: The selection of preset frequencies when P3.3.3.1 = Binary coded**

Activated digital input signal			Activated frequency reference
Preset Freq Sel2 (P3.3.3.12)	Preset Freq Sel1 (P3.3.3.11)	Preset Freq Sel0 (P3.3.3.10)	
			Preset frequency 0 Only if Preset Freq 0 is set as frequency reference source with P3.3.3.1.5, P3.3.1.6, P3.3.1.7 or P3.3.1.10.
		*	Preset frequency 1
	*		Preset frequency 2
	*	*	Preset frequency 3
*			Preset frequency 4
*		*	Preset frequency 5
*	*		Preset frequency 6
*	*	*	Preset frequency 7

\* = the input is activated.

#### VALUE 1 SELECTED FOR PARAMETER P3.3.3.1:

You can use the Preset Frequencies 1 to 3 with different sets of active digital inputs. The number of active inputs tells which one is used.

**Table 120: The selection of preset frequencies when P3.3.3.1 = Number of inputs**

Activated digital input signal			Activated frequency reference
Preset Freq Sel2 (P3.3.3.12)	Preset Freq Sel1 (P3.3.3.11)	Preset Freq Sel0 (P3.3.3.10)	
			Preset frequency 0 Only if Preset Freq 0 is set as frequency reference source with P3.3.3.1.5, P3.3.1.6, P3.3.1.7 or P3.3.1.10.
		*	Preset frequency 1
	*		Preset frequency 1
*			Preset frequency 1
	*	*	Preset frequency 2
*		*	Preset frequency 2
*	*		Preset frequency 2
*	*	*	Preset frequency 3

\* = the input is activated.

### **P3.3.3.10 PRESET FREQUENCY SELECTION 0 (ID 419)**

Use this parameter to select the digital input signal that is used as a selector for the preset frequencies.

This parameter is a binary selector for Preset speeds (0-7). See parameters P3.3.3.2 to P3.3.3.9.

### **P3.3.3.11 PRESET FREQUENCY SELECTION 1 (ID 420)**

Use this parameter to select the digital input signal that is used as a selector for the preset frequencies.

This parameter is a binary selector for Preset speeds (0-7). See parameters P3.3.3.2 to P3.3.3.9.

### **P3.3.3.12 PRESET FREQUENCY SELECTION 2 (ID 421)**

Use this parameter to select the digital input signal that is used as a selector for the preset frequencies.

This parameter is a binary selector for Preset speeds (0-7). See parameters P3.3.3.2 to P3.3.3.9.

To apply Preset frequencies 1 to 7, connect a digital input to these functions with the instructions in Chapter 10.6.1 *Programming of digital and analogue inputs*. See more data in Table 119 *The selection of preset frequencies when P3.3.3.1 = Binary coded* and also in Table 42 *Preset frequency parameters* and Table 51 *Digital input settings*.

### 10.4.5 MOTOR POTENTIOMETER PARAMETERS

The frequency reference of the Motor Potentiometer is available in all the control places. You can change the motor potentiometer reference only when the drive is in the run state.



#### NOTE!

If you set the output frequency slower than the Motor Potentiometer Ramp Time, the normal acceleration and deceleration times give limits to it.

#### P3.3.4.1 MOTOR POTENTIOMETER UP (ID 418)

Use this parameter to increase the output frequency with a digital input signal.

With a motor potentiometer, you can increase and decrease the output frequency. When you connect a digital input to parameter Motor Potentiometer UP, and have the digital input signal active, the output frequency rises.

The motor potentiometer reference INCREASES until the contact is opened.

#### P3.3.4.2 MOTOR POTENTIOMETER DOWN (ID 417)

Use this parameter to decrease the output frequency with a digital input signal.

With a motor potentiometer, you can increase and decrease the output frequency. When you connect a digital input to parameter Motor Potentiometer DOWN, and have the digital input signal active, the output frequency falls.

The motor potentiometer reference DECREASES until the contact is opened.

3 different parameters have an effect on how the output frequency rises or falls when Motor Potentiometer UP or DOWN is active. These parameters are Motor Potentiometer Ramp Time (P3.3.4.3), Acceleration Time (P3.4.1.2), and Deceleration Time (P3.4.1.3).

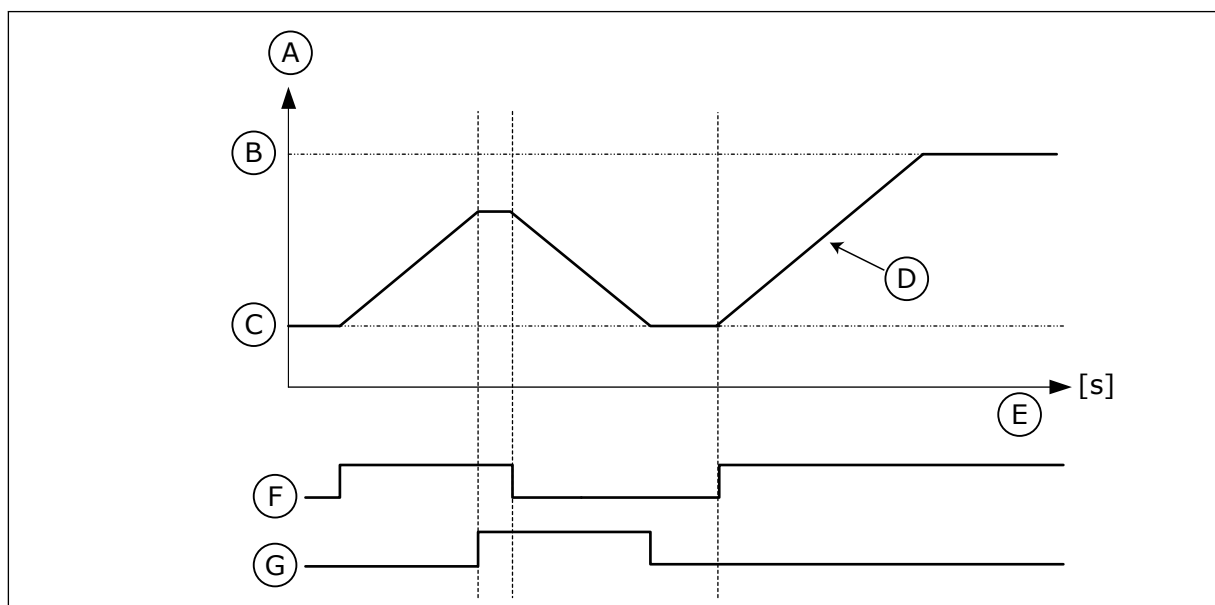

Fig. 37: The motor potentiometer parameters

- |                        |                                  |
|------------------------|----------------------------------|
| A. Frequency Reference | D. Motor potentiometer ramp time |
| B. Max Frequency       | E. Time                          |
| C. Min Frequency       | F. Motor potentiometer UP        |
|                        | G. Motor potentiometer DOWN      |

**P3.3.4.3 MOTOR POTENTIOMETER RAMP TIME (ID 331)**

Use this parameter to set the rate of change in the motor potentiometer reference when it is increased or decreased.

The parameter value is entered as Hz/second.

**P3.3.4.4 MOTOR POTENTIOMETER RESET (ID 367)**

Use this parameter to set the logic for the resetting of the frequency reference of the motor potentiometer.

This parameter defines when the reference of the motor potentiometer is set to 0.

There are 3 selections in the reset function: no reset, reset when the drive stops, or reset when the drive is powered down.

Selection number	Selection name	Description
0	No reset	The last motor potentiometer frequency reference is kept through the stop state and kept in memory if a powerdown occurs.
1	Stop state	The motor potentiometer frequency reference is set to 0 when the drive goes to the stop state, or when the drive is powered down.
2	Powered down	The motor potentiometer frequency reference is set to 0 only when a powerdown occurs.

**10.4.6 JOYSTICK PARAMETERS**

Use the joystick parameters when you control the frequency reference or the torque reference of the motor with a joystick. To control the motor with a joystick, connect the joystick signal to an analogue input and set the joystick parameters.

**CAUTION!**

We recommend strongly that you use the Joystick function with analogue inputs of the range -10V...+10V. In this case, if a wire breaks, the reference does not go to the maximum value.

**P3.3.5.1 JOYSTICK SIGNAL SELECTION (ID 451)**

Use this parameter to set the analogue input signal that controls the Joystick function.

Use the Joystick function to control the frequency reference of the drive or the torque reference.

**P3.3.5.2 JOYSTICK DEAD ZONE (ID 384)**

Use this parameter to set the joystick dead zone.

To ignore the small values of the reference around 0, set this value to be bigger than 0. When the analogue input signal is  $0 \pm$  the value of this parameter, the joystick reference is set to 0.

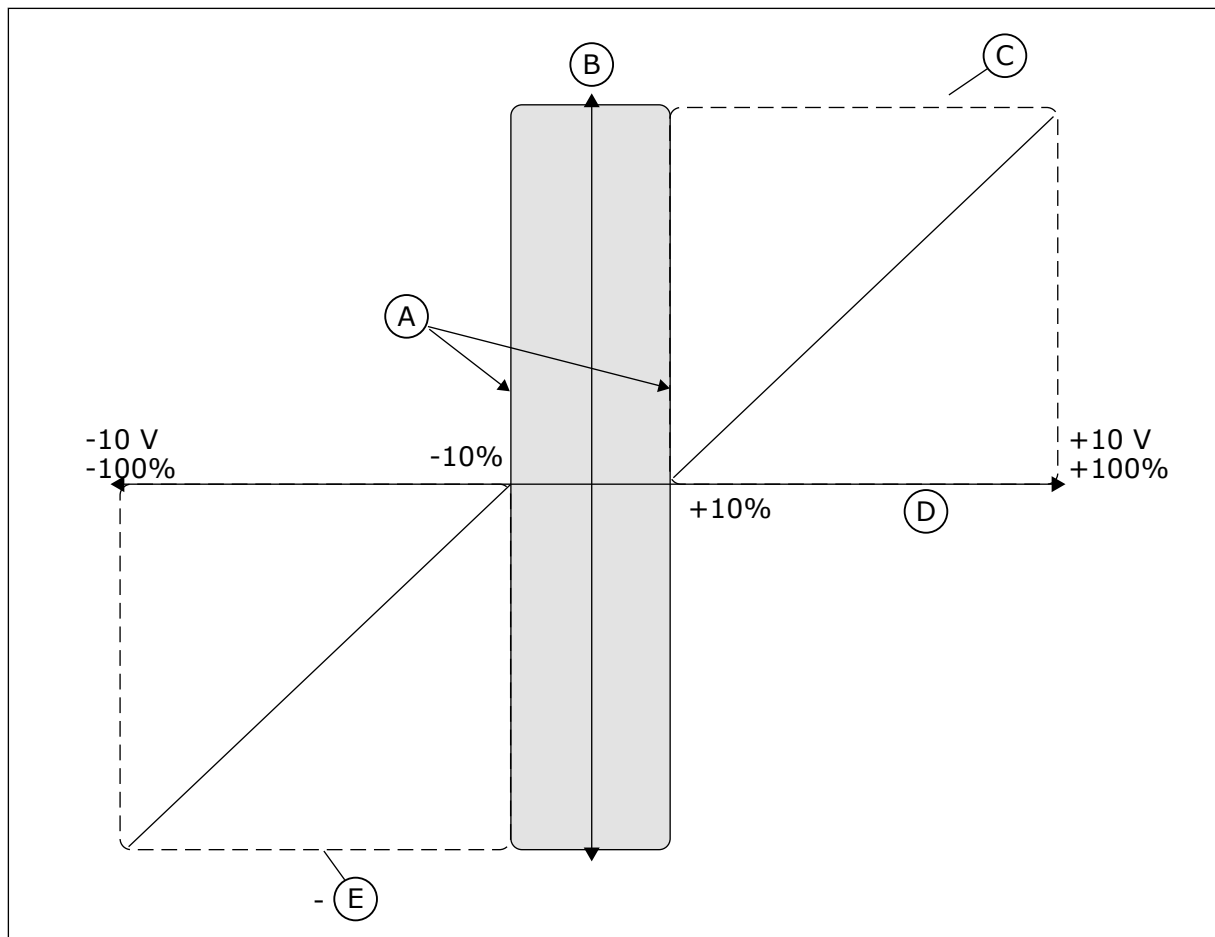

Fig. 38: The Joystick function

- |                                 |                   |
|---------------------------------|-------------------|
| A. AI joystick dead zone = 10 % | D. Analogue input |
| B. Reference                    | E. MaxFreq        |
| C. MaxFreq                      |                   |

### P3.3.5.3 JOYSTICK SLEEP ZONE (ID 385)

Use this parameter to set the joystick sleep zone. The AC drive stops if the joystick reference stays in the sleep zone for longer than the time period defined in parameter P3.3.5.4 Joystick Sleep Delay.



#### NOTE!

The Sleep function is available only if you use the joystick to control the frequency reference.

### P3.3.5.4 JOYSTICK SLEEP DELAY (ID 386)

Use this parameter to set the joystick sleep delay. If the joystick reference stays in the set sleep zone for longer than the sleep delay, the drive stops and the sleep mode is activated.



**NOTE!**

The Joystick sleep function is disabled when the value of this parameter is set to 0.

### 10.4.7 JOGGING PARAMETERS

Use the Jogging function to override the normal control momentarily. You can use this function, for example, to control the process slowly to a special status or position during maintenance. You do not have to change the control place or other parameters.

Only when the drive is in stop state, it is possible to activate the Jogging function. You can use 2 bi-directional frequency references. You can activate the Jogging function from the fieldbus or by digital input signals. The Jogging function has a ramp time that is used always when jogging is active.

The Jogging function starts the drive at the set reference. A new start command is not necessary. The control place does not have an effect on this.

You can activate the Jogging function from the fieldbus in bypass mode with Control Word bits 10 and 11.

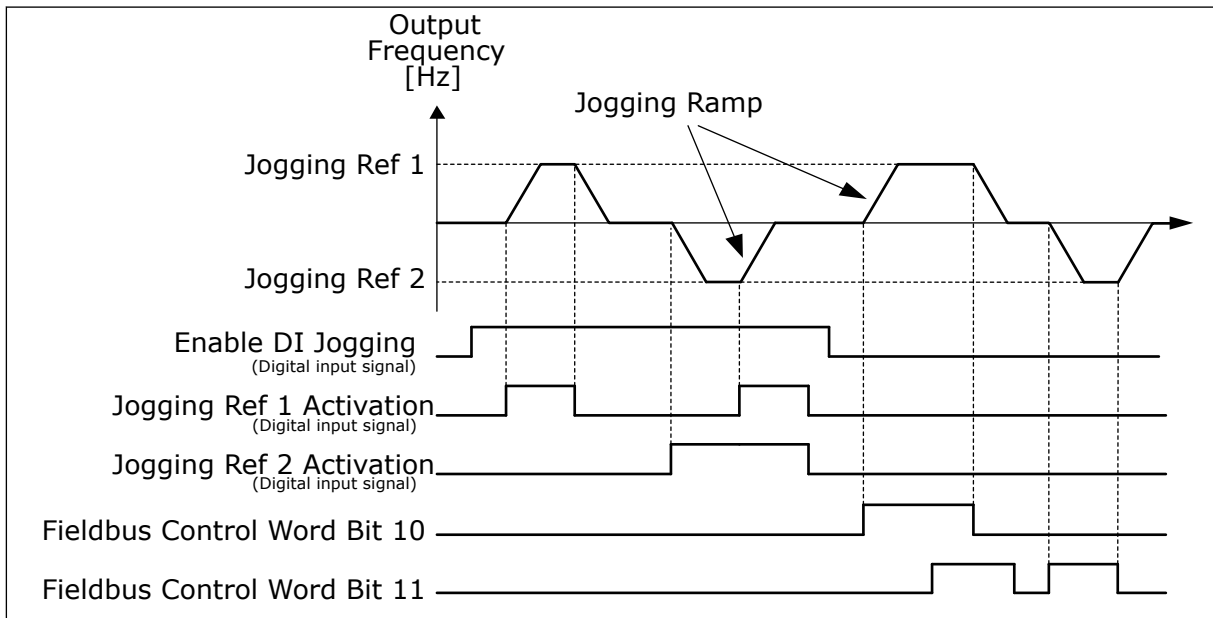

Fig. 39: The Jogging parameters

#### **P3.3.6.1 ENABLE DI JOGGING (ID 532)**

Use this parameter to enable the jogging commands from digital inputs.

This parameter gives the digital input signal that is used to enable jogging commands from digital inputs. This signal does not have an effect on the jogging commands that come from Fieldbus.

#### **P3.3.6.2 JOGGING REFERENCE 1 ACTIVATION (ID 530)**

Use this parameter to set the digital input signals for the Jogging function activation.

This parameter gives the digital input signal that is used to set the frequency reference for Jogging function and make the drive start. You can use this digital input signal only when Enable DI Jogging is active.

**NOTE!**

If you activate Enable DI Jogging and this digital input, the drive starts.

**NOTE!**

If the 2 activation signals are active at the same time, the drive stops.

***P3.3.6.3 JOGGING REFERENCE 2 ACTIVATION (ID 531)***

Use this parameter to set the digital input signals for the Jogging function activation. This parameter gives the digital input signal that is used to set the frequency reference for Jogging function and make the drive start. You can use this digital input signal only when Enable DI Jogging is active.

**NOTE!**

If you activate Enable DI Jogging and this digital input, the drive starts.

**NOTE!**

If the 2 activation signals are active at the same time, the drive stops.

***P3.3.6.4 JOGGING REFERENCE 1 (ID 1239)***

Use this parameter to set the frequency references for the jogging function. With the parameters P3.3.6.4 and P3.3.6.5, you can set the frequency references for the jogging function. The references are bi-directional. A reverse command does not have an effect on the direction of the jogging references. The reference for the forward direction has a positive value, and the reference for the reverse direction has a negative value. You can activate the jogging function with digital input signals or from Fieldbus in bypass mode with Control Word bits 10 and 11.

***P3.3.6.5 JOGGING REFERENCE 2 (ID 1240)***

Use this parameter to set the frequency references for the jogging function. With the parameters P3.3.6.4 and P3.3.6.5, you can set the frequency references for the jogging function. The references are bi-directional. A reverse command does not have an effect on the direction of the jogging references. The reference for the forward direction has a positive value, and the reference for the reverse direction has a negative value. You can activate the jogging function with digital input signals or from Fieldbus in bypass mode with Control Word bits 10 and 11.

***P3.3.6.6 JOGGING RAMP (ID 1257)***

Use this parameter to set the ramp time when jogging is active. This parameter gives the acceleration and deceleration times when the Jogging function is active.

## 10.5 RAMPS AND BRAKES SETUP

### 10.5.1 RAMP 1

#### **P3.4.1.1 RAMP 1 SHAPE (ID 500)**

Use this parameter to make the start and the end of the acceleration and deceleration ramps smoother.

With the parameters Ramp 1 Shape and Ramp 2 Shape, you can make smoother the start and the end of the acceleration and deceleration ramps. If you set the value to 0.0%, you get a linear ramp shape. The acceleration and deceleration act immediately to the changes in the reference signal.

When you set the value between 1.0% and 100.0%, you get an S-shaped acceleration or deceleration ramp. Use this function to reduce mechanical erosion of the parts and current spikes when the reference changes. You can modify the acceleration time with parameters P3.4.1.2 (Acceleration Time 1) and P3.4.1.3 (Deceleration Time 1).

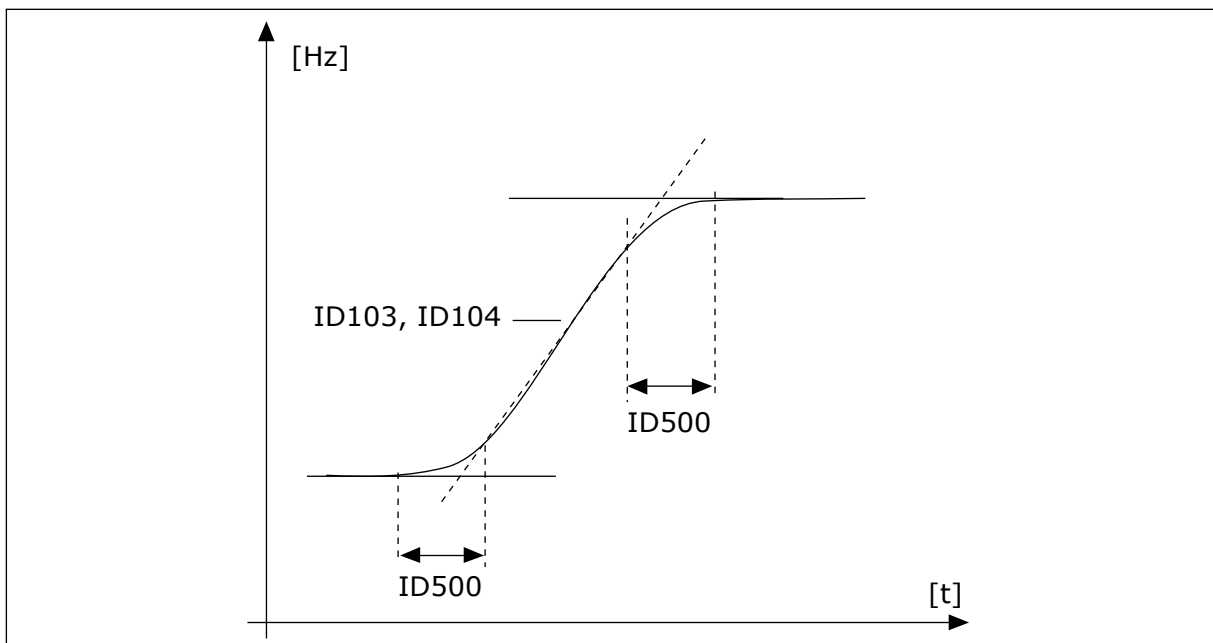

Fig. 40: The acceleration/deceleration curve (S-shaped)

#### **P3.4.1.2 ACCELERATION TIME 1 (ID 103)**

Use this parameter to set the time that is necessary for the output frequency to increase from zero frequency to maximum frequency.

#### **P3.4.1.3 DECELERATION TIME 1 (ID 104)**

Use this parameter to set the time that is necessary for the output frequency to decrease from maximum frequency to zero frequency.

## 10.5.2 RAMP 2

### P3.4.2.1 RAMP 2 SHAPE (ID 501)

Use this parameter to make the start and the end of the acceleration and deceleration ramps smoother.

With the parameters Ramp 1 Shape and Ramp 2 Shape, you can make smoother the start and the end of the acceleration and deceleration ramps. If you set the value to 0.0%, you get a linear ramp shape. The acceleration and deceleration act immediately to the changes in the reference signal.

When you set the value between 1.0% and 100.0%, you get an S-shaped acceleration or deceleration ramp. Use this function to reduce mechanical erosion of the parts and current spikes when the reference changes. You can modify the acceleration time with parameters P3.4.2.2 (Acceleration Time 2) and P3.4.2.3 (Deceleration Time 2).

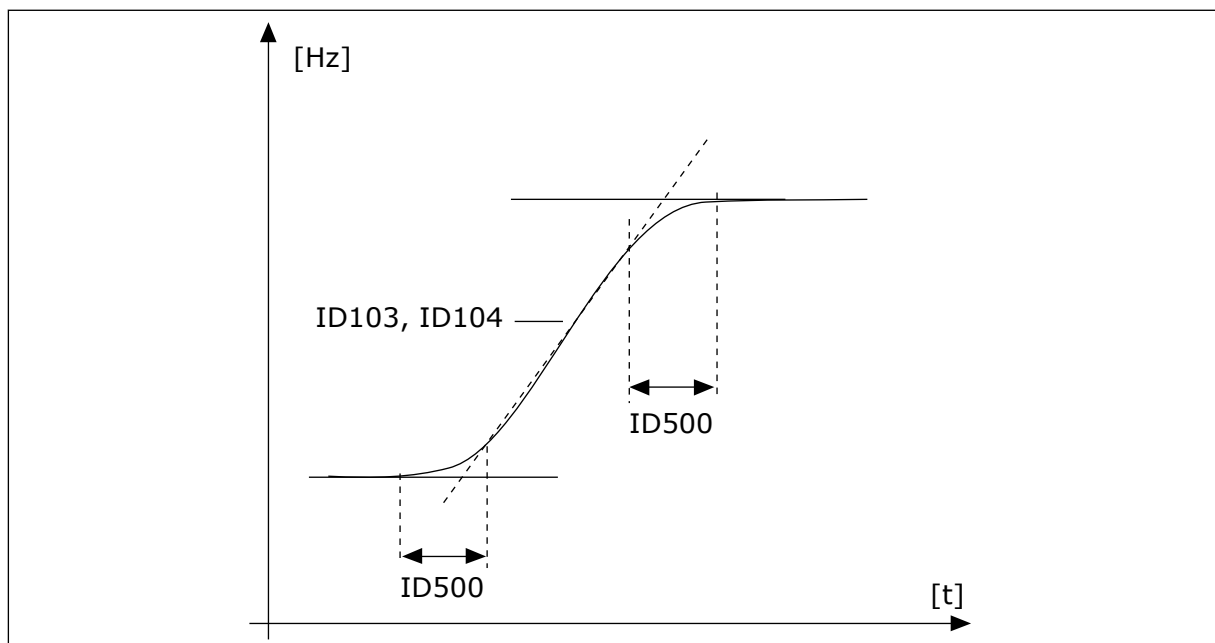

Fig. 41: The acceleration/deceleration curve (S-shaped)

### P3.4.2.2 ACCELERATION TIME 2 (ID 502)

Use this parameter to set the time that is necessary for the output frequency to increase from zero frequency to maximum frequency.

### P3.4.2.3 DECELERATION TIME 2 (ID 503)

Use this parameter to set the time that is necessary for the output frequency to decrease from maximum frequency to zero frequency.

### P3.4.2.4 RAMP 2 SELECTION (ID 408)

Use this parameter to select either ramp 1 or ramp 2.

Selection number	Selection name	Description
0	OPEN	Ramp 1 Shape, Acceleration Time 1 and Deceleration Time 1
1	CLOSED	Ramp 2 Shape, Acceleration Time 2 and Deceleration Time 2

### 10.5.3 START MAGNETISING

#### ***P3.4.3.1 START MAGNETISING CURRENT (ID 517)***

Use this parameter to set the DC current that is fed into the motor at the start. If the value of this parameter is set to 0, the Start Magnetising function is disabled.

#### ***P3.4.3.2 START MAGNETISING TIME (ID 516)***

Use this parameter to set the time during which the DC current is fed to the motor before the acceleration starts.

### 10.5.4 DC BRAKE

#### ***P3.4.4.1 DC BRAKE CURRENT (ID 507)***

Use this parameter to set the current that is fed into the motor during DC braking. If the value of this parameter is set to 0, the DC Brake function is disabled.

#### ***P3.4.4.2 DC BRAKING TIME AT STOP (ID 508)***

Use this parameter to set the braking is ON or OFF and to give the braking time when the motor stops.

If the value of this parameter is set to 0, the DC Brake function is disabled.

#### ***P3.4.4.3 FREQUENCY TO START DC BRAKING AT RAMP STOP (ID 515)***

Use this parameter to set the output frequency at which the DC braking starts.

### 10.5.5 FLUX BRAKING

#### ***P3.4.5.1 FLUX BRAKING (ID 520)***

Use this parameter to enable Flux Braking.

You can use flux braking as an alternative to DC braking. Flux braking increases the braking capacity in conditions where additional brake resistors are not necessary.

When braking is necessary, the system decreases the frequency and increases the flux in the motor. This increases the capacity of the motor to brake. The motor speed is controlled during braking.

**CAUTION!**

Use the braking only intermittently. Flux braking converts energy into heat and can cause damage to the motor.

**P3.4.5.2 FLUX BRAKING CURRENT (ID 519)**

Use this parameter to set the current level for the flux braking.

**10.6 I/O CONFIGURATION****10.6.1 PROGRAMMING OF DIGITAL AND ANALOGUE INPUTS**

The programming of inputs of the AC drive is flexible. You can freely use the available inputs of the standard and optional I/O for different functions.

It is possible to expand the available capacity of I/O with option boards. You can install the option boards in the slots C, D and E. You can find more data on the installation of option boards in the Installation manual.

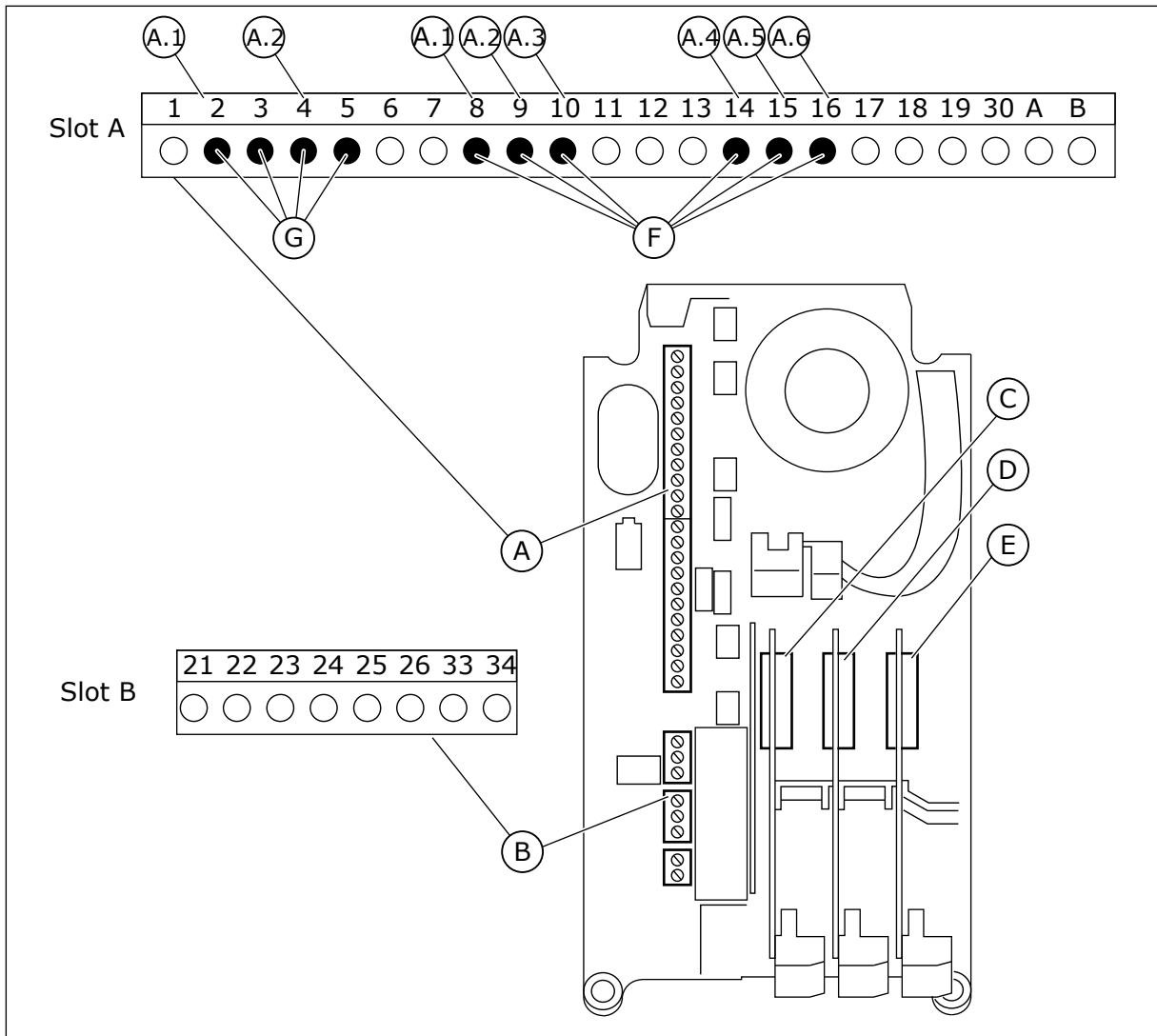

Fig. 42: The option board slots and programmable inputs

- A. Standard board slot A and its terminals
- B. Standard board slot B and its terminals
- C. Option board slot C
- D. Option board slot D
- E. Option board slot E
- F. Programmable digital inputs (DI)
- G. Programmable analogue inputs (AI)

10.6.1.1 Programming of digital inputs

You can find the applicable functions for digital inputs as parameters in parameter group M3.5.1. To give a digital input to a function, set a value to the correct parameter. The list of applicable functions shows in *Table 51 Digital input settings*.

**Example**

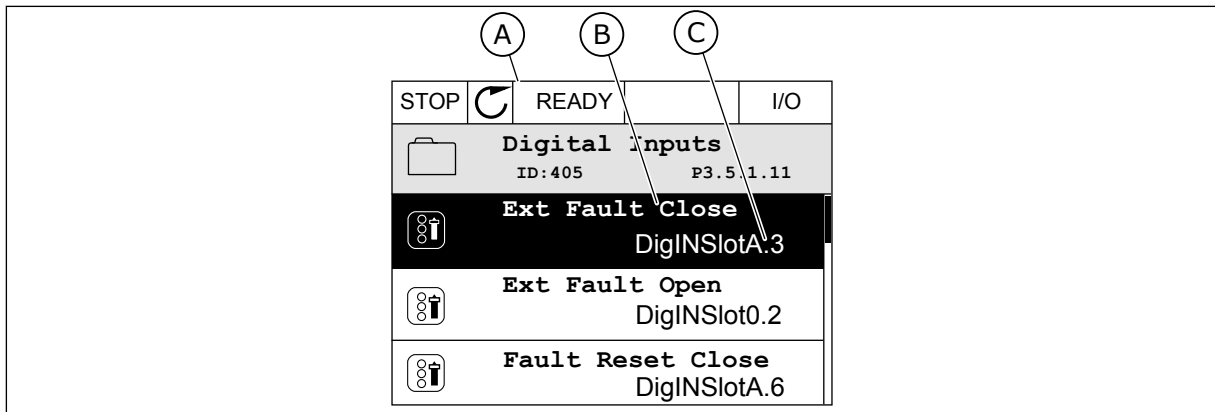

Fig. 43: The Digital inputs menu in the graphical display

- A. The graphical display
- B. The name of the parameter, that is, the function
- C. The value of the parameter, that is, the set digital input

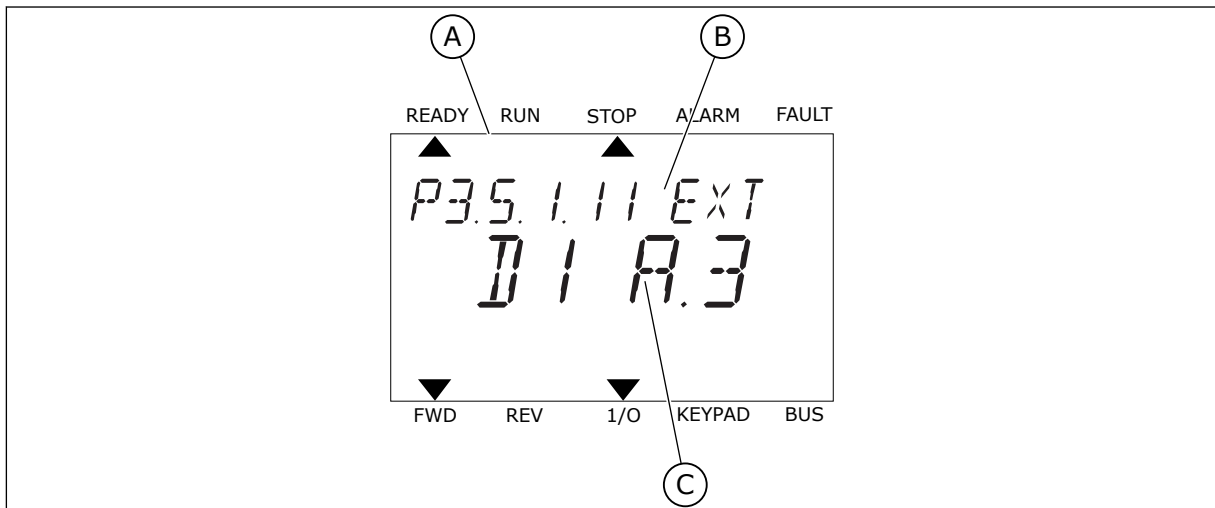

Fig. 44: The Digital inputs menu in the text display

- A. The text display
- B. The name of the parameter, that is, the function
- C. The value of the parameter, that is, the set digital input

In the standard I/O board compilation, there are 6 digital inputs available: the slot A terminals 8, 9, 10, 14, 15 and 16.



Input type (graphical display)	Input type (text display)	Slot	Input #	Explanation
DigIN	dl	A	1	Digital input #1 (terminal 8) on a board in Slot A (standard I/O board).
DigIN	dl	A	2	Digital input #2 (terminal 9) on a board in Slot A (standard I/O board).
DigIN	dl	A	3	Digital input #3 (terminal 10) on a board in Slot A (standard I/O board).
DigIN	dl	A	4	Digital input #4 (terminal 14) on a board in Slot A (standard I/O board).
DigIN	dl	A	5	Digital input #5 (terminal 15) on a board in Slot A (standard I/O board).
DigIN	dl	A	6	Digital input #6 (terminal 16) on a board in Slot A (standard I/O board).

The function External Fault Close, the location of which is the menu M3.5.1, is parameter P3.5.1.11. It gets the default value DigIN SlotA.3 in the graphical display, and dl A.3 in the text display. After this selection, a digital signal to the digital input DI3 (terminal 10) controls External Fault Close.

Index	Parameter	Default	ID	Description
P3.5.1.11	External fault close	DigIN SlotA.3	405	OPEN = OK CLOSED = External fault

To change the input from DI3 to, for example, DI6 (terminal 16) on the standard I/O, obey these instructions.

**PROGRAMMING IN THE GRAPHICAL DISPLAY**

- 1 Make a selection of a parameter. To go into the Edit mode, push the arrow button Right.

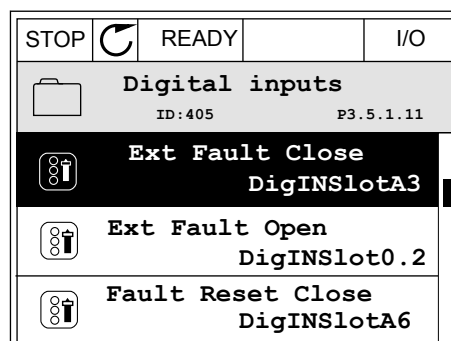

- In the Edit mode, the slot value DigIN SlotA is underlined and blinks. If you have more digital inputs available in your I/O, for example, because of option boards in slots C, D or E, make a selection of them.

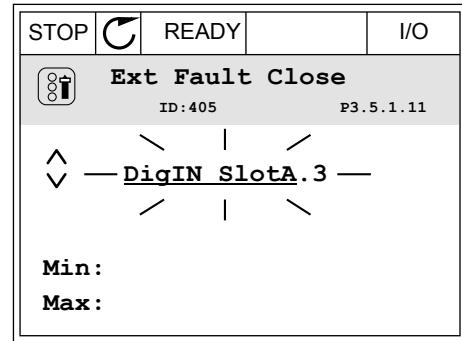

- To activate the terminal 3, push the arrow button Right again.

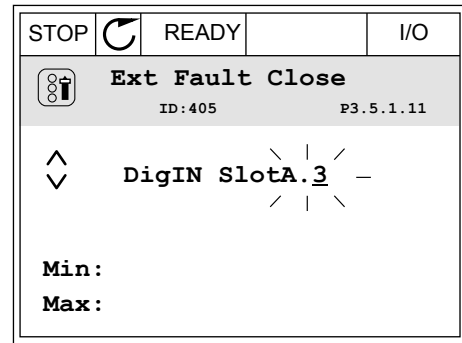

- To change the terminal to 6, push the arrow button Up 3 times. Accept the change with the OK button.

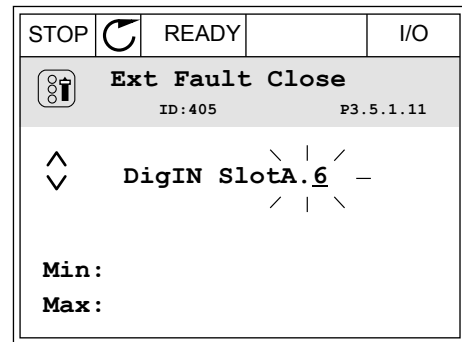

- If the digital input DI6 was already used for some other function, a message shows on the display. Change one of these selections.

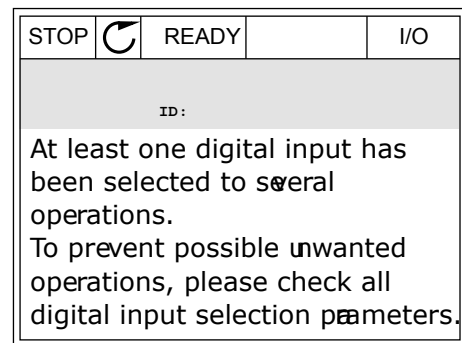

## PROGRAMMING IN THE TEXT DISPLAY

- 1 Make a selection of a parameter. To go into the Edit mode, push the OK button.

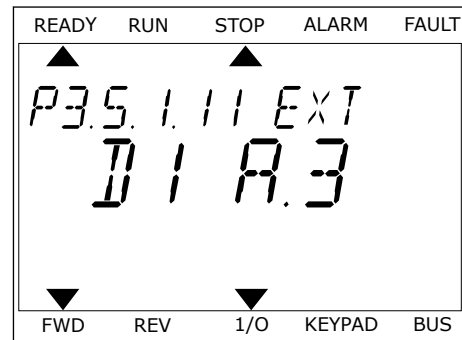

- 2 In the Edit mode, the letter D blinks. If you have more digital inputs available in your I/O, for example, because of option boards in slots C, D or E, make a selection of them.

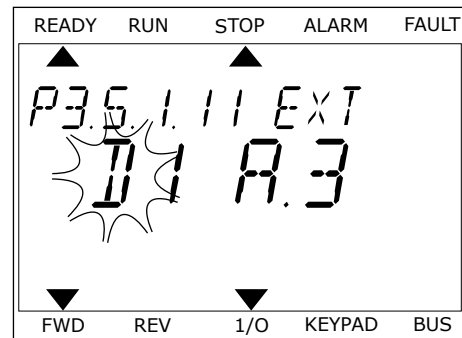

- 3 To activate the terminal 3, push the arrow button Right again. The letter D stops blinking.

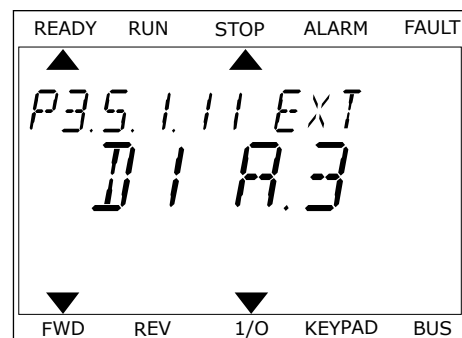

- 4 To change the terminal to 6, push the arrow button Up 3 times. Accept the change with the OK button.

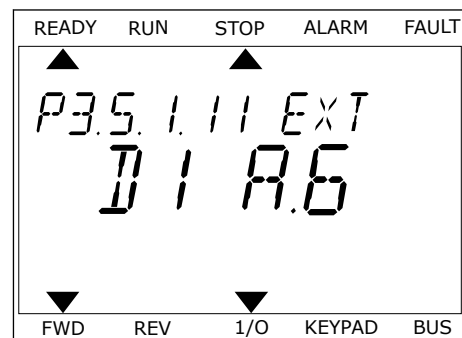

- 5 If the digital input DI6 was already used for some other function, a message scrolls on the display. Change one of these selections.

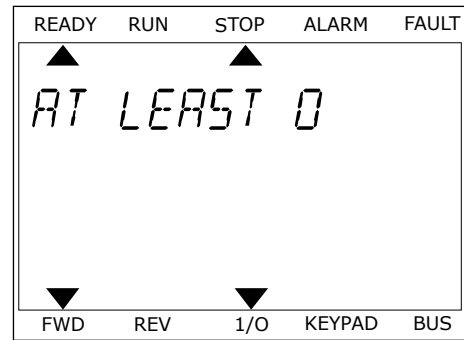

After the steps, a digital signal to the digital input DI6 controls the function External Fault Close.

The value of a function can be DigIN Slot0.1 (in the graphical display) or dl 0.1 (in the text display). In these conditions, you did not give a terminal to the function, or the the input was set to be always OPEN. This is the default value of most of parameters in the group M3.5.1. On the other hand, some inputs have the default value always CLOSED. Their value shows DigIN Slot0.2 in the graphical display and dl 0.2 in the text display.



**NOTE!**

You can also give time channels to digital inputs. There is more data about it in *Table 88 Sleep function settings*.

10.6.1.2 Programming of analogue inputs

You can make a selection of the target input for the signal of the analogue frequency reference from the available analogue inputs.

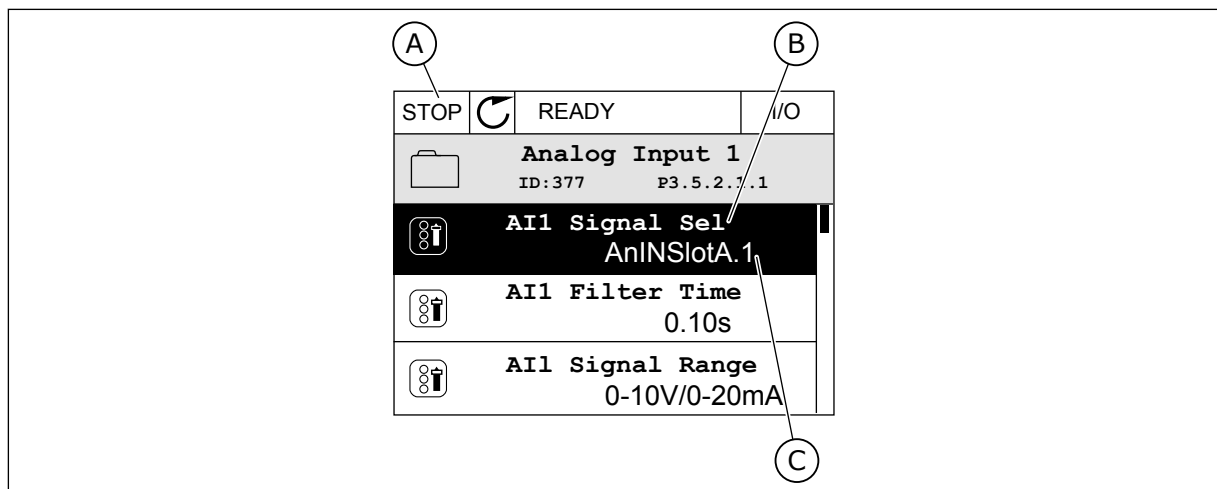

Fig. 45: The Analogue inputs menu in the graphical display

- A. The graphical display
- B. The name of the parameter
- C. The value of the parameter, that is, the set analogue input

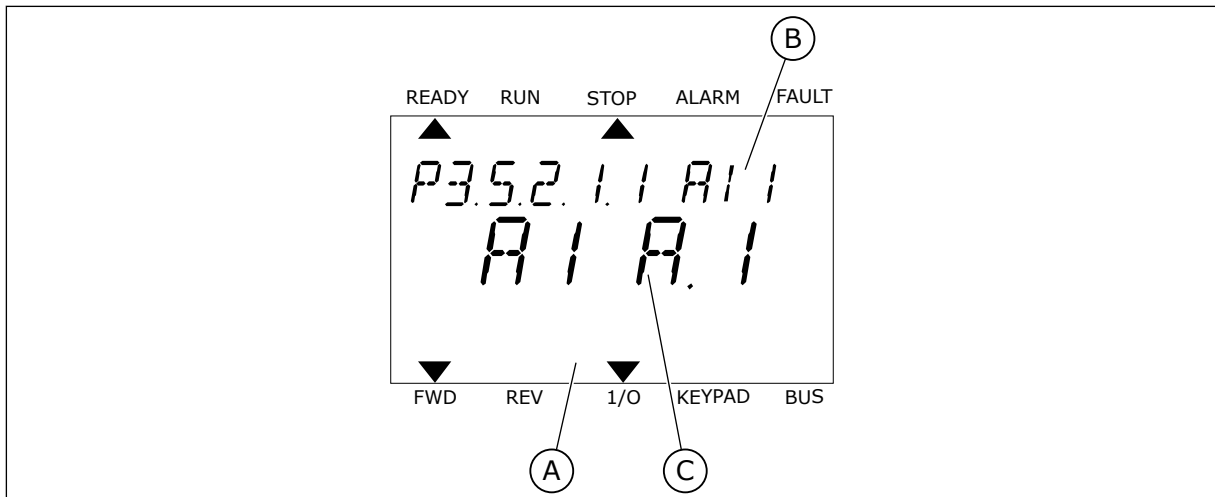

Fig. 46: The Analogue inputs menu in the text display

- A. The text display
- B. The name of the parameter
- C. The value of the parameter, that is, the set analogue input

In the standard I/O board compilation, there are 2 analogue inputs available: the slot A terminals 2/3 and 4/5.

Input type (graphical display)	Input type (text display)	Slot	Input #	Explanation
AnIN	AI	A	1	Analogue input #1 (terminals 2/3) on a board in Slot A (standard I/O board).
AnIN	AI	A	2	Analogue input #2 (terminals 4/5) on a board in Slot A (standard I/O board).

The location of the parameter P3.5.2.1.1 AI1 Signal Selection is the menu M3.5.2.1. The parameter gets the default value AnIN SlotA.1 in the graphical display or AI A.1 in the text display. The target input for the signal of the analogue frequency reference AI1 is then the analogue input in the terminals 2/3. Use the dip switches to set the signal to be voltage or current. See the Installation manual for more data.

Index	Parameter	Default	ID	Description
P3.5.2.1.1	AI1 Signal Selection	AnIN SlotA.1	377	

To change the input from AI1 to, for example, the analogue input on your option board in slot C, obey these instructions.

**PROGRAMMING OF ANALOGUE INPUTS IN THE GRAPHICAL DISPLAY**

- 1 To make a selection of the parameter, push the arrow button Right.

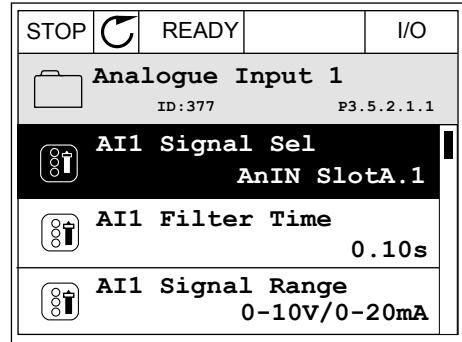

- 2 In the Edit mode, the value AnIN SlotA is underlined and blinks.

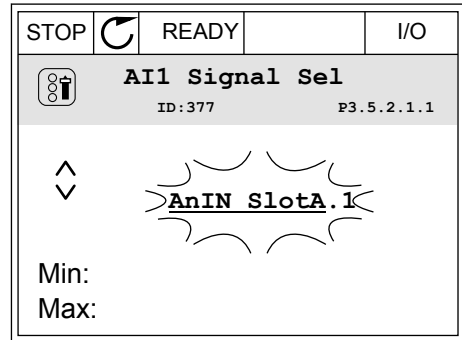

- 3 To change the value to AnIN SlotC, push the arrow button Up. Accept the change with the OK button.

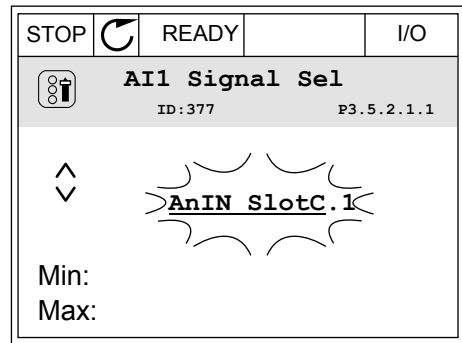

**PROGRAMMING OF ANALOGUE INPUTS IN THE TEXT DISPLAY**

- 1 To make a selection of the parameter, push the OK button.

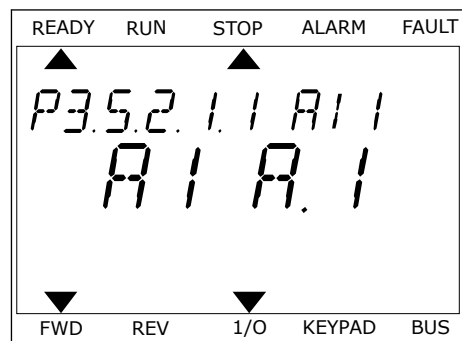

- 2 In the Edit mode, the letter A blinks.

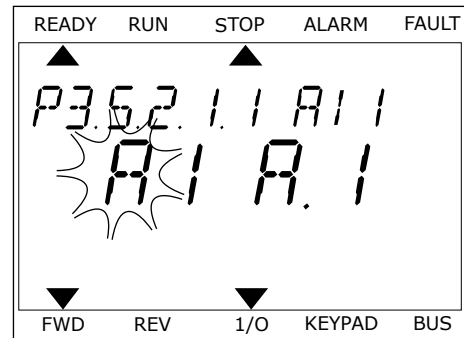

- 3 To change the value to C, push the arrow button Up. Accept the change with the OK button.

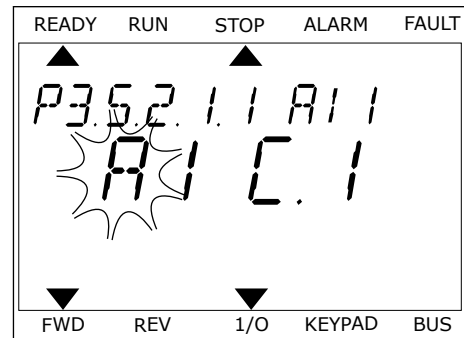

### 10.6.1.3 Descriptions of signal sources

Source	Function
Slot0.#	<p>Digital inputs:</p> <p>You can use this function to set a digital signal to be in a constant OPEN or CLOSED state. The manufacturer set some signals so that they are always in the CLOSED state, for example parameter P3.5.1.15 (Run Enable). The Run Enable signal is always on if you do not change it.</p> <p># = 1: Always OPEN # = 2-10: Always CLOSED</p> <p>Analogue inputs (used for testing purposes):</p> <p># = 1: Analogue input = 0% of the signal strength # = 2: Analogue input = 20% of the signal strength # = 3: Analogue input = 30% of the signal strength etc. # = 10: Analogue input = 100% of the signal strength</p>
SlotA.#	Number (#) agrees to a digital input in slot A.
SlotB.#	Number (#) agrees to a digital input in slot B.
SlotC.#	Number (#) agrees to a digital input in slot C.
SlotD.#	Number (#) agrees to a digital input in slot D.
SlotE.#	Number (#) agrees to a digital input in slot E.
TimeChannel.#	1=Time Channel1, 2=Time Channel2, 3=Time Channel3
FieldbusCW.#	Number (#) refers to a control word bit number.
FieldbusPD.#	Number (#) refers to the process data 1 bit number.
BlockOut.#	Number (#) refers to an output of the corresponding function block in the Drive customizer.



## 10.6.2 DEFAULT FUNCTIONS OF PROGRAMMABLE INPUTS

**Table 121: Default functions of the programmable digital and analogue inputs**

Input	Terminal(s)	Reference	Function	Parameter index
DI1	8	A.1	Control Signal 1 A	P3.5.1.1
DI2	9	A.2	Control Signal 2 A	P3.5.1.2
DI3	10	A.3	External Fault Close	P3.5.1.11
DI4	14	A.4	Preset Frequency Selection 0	P3.5.1.21
DI5	15	A.5	Preset Frequency Selection 1	P3.5.1.22
DI6	16	A.6	Fault Reset Close	P3.5.1.13
AI1	2/3	A.1	AI1 Signal Selection	P3.5.2.1.1
AI2	4/5	A.2	AI2 Signal Selection	P3.5.2.2.1

### 10.6.3 DIGITAL INPUTS

The parameters are functions that you can connect to a digital input terminal. The text *DigIn Slot A.2* means the second input on the slot A. It is also possible to connect the functions to time channels. The time channels work as terminals.

You can monitor the statuses of the digital inputs and the digital outputs in the Multimonitoring view.

#### **P3.5.1.1 CONTROL SIGNAL 1 A (ID 403)**

Use this parameter to select the digital input signal (Control Signal 1) that starts and stops the drive when the control place is I/O A (FWD).

#### **P3.5.1.2 CONTROL SIGNAL 2 A (ID 404)**

Use this parameter to select the digital input signal (Control Signal 2) that starts and stops the drive when the control place is I/O A (REV).

#### **P3.5.1.3 CONTROL SIGNAL 3 A (ID 434)**

Use this parameter to select the digital input signal (Control Signal 3) that starts and stops the drive when the control place is I/O A.

#### **P3.5.1.4 CONTROL SIGNAL 1 B (ID 423)**

Use this parameter to select the digital input signal (Control Signal 1) that starts and stops the drive when the control place is I/O B.

**P3.5.1.5 CONTROL SIGNAL 2 B (ID 424)**

Use this parameter to select the digital input signal (Control Signal 2) that starts and stops the drive when the control place is I/O B.

**P3.5.1.6 CONTROL SIGNAL 3 B (ID 435)**

Use this parameter to select the digital input signal (Control Signal 3) that starts and stops the drive when the control place is I/O B.

**P3.5.1.7 I/O B CONTROL FORCE (ID 425)**

Use this parameter to select the digital input signal that switches the control place from I/O A to I/O B.

**P3.5.1.8 I/O B REFERENCE FORCE (ID 343)**

Use this parameter to select the digital input signal that switches the frequency reference source from I/O A to I/O B.

**P3.5.1.9 FIELD BUS CONTROL FORCE (ID 411)**

Use this parameter to select the digital input signal that switches the control place and the frequency reference source to Fieldbus (from I/O A, I/O B or Local control).

**P3.5.1.10 KEYPAD CONTROL FORCE (ID 410)**

Use this parameter to select the digital input signal that switches the control place and the frequency reference source to Keypad (from any control place).

**P3.5.1.11 EXTERNAL FAULT CLOSE (ID 405)**

Use this parameter to select the digital input signal that activates an external fault.

**P3.5.1.12 EXTERNAL FAULT OPEN (ID 406)**

Use this parameter to select the digital input signal that activates an external fault.

**P3.5.1.13 FAULT RESET CLOSE (ID 414)**

Use this parameter to select the digital input signal that resets all active faults. Active faults are reset when the state of the digital input changes from open to closed (rising edge).

**P3.5.1.14 FAULT RESET OPEN (ID 213)**

Use this parameter to select the digital input signal that resets all active faults. Active faults are reset when the state of the digital input changes from closed to open (falling edge).

**P3.5.1.15 RUN ENABLE (ID 407)**

Use this parameter to select the digital input signal that sets the drive to Ready state. When the contact is OPEN, the start of the motor is disabled.

When the contact is CLOSED, the start of the motor is enabled.

**NOTE!**

The state of the drive remains in 'Not Ready' if the state of this signal is 'opened'. If the Run Enable signal is used for stopping the drive, the drive will always coast to stop regardless of the selection in parameter P3.2.5 Stop Function.

***P3.5.1.16 RUN INTERLOCK 1 (ID 1041)***

Use this parameter to select the digital input signal that prevents to start the drive. The drive can be ready but start is not possible when the state of the interlock signal is 'open' (damper interlock).

***P3.5.1.17 RUN INTERLOCK 2 (ID 1042)***

Use this parameter to select the digital input signal that prevents to start the drive. The drive can be ready but start is not possible when the state of the interlock signal is 'open' (damper interlock).

If an interlock is active, the drive cannot start.

You can use this function to prevent the start of the drive when the damper is closed. If you activate an interlock during the operation of the drive, the drive stops.

***P3.5.1.18 MOTOR PREHEAT ON (ID 1044)***

Use this parameter to select the digital input signal that activates Motor Preheat function. The Motor Preheat function feeds DC-current to the motor when the drive is in the stop state.

***P3.5.1.19 RAMP 2 SELECTION (ID 408)***

Use this parameter to select the digital input signal that selects the ramp time to be used.

***P3.5.1.20 ACC/DEC PROHIBIT (ID 415)***

Use this parameter to select the digital input signal that prevents the acceleration and the deceleration of the drive. No acceleration or deceleration is possible until the contact is open.

***P3.5.1.21 PRESET FREQUENCY SELECTION 0 (ID 419)***

Use this parameter to set the digital input signal that selects the preset frequencies.

***P3.5.1.22 PRESET FREQUENCY SELECTION 1 (ID 420)***

Use this parameter to set the digital input signal that selects the preset frequencies.

***P3.5.1.23 PRESET FREQUENCY SELECTION 2 (ID 421)***

Use this parameter to set the digital input signal that selects the preset frequencies.

**P3.5.1.24 MOTOR POTENTIOMETER UP (ID 418)**

Use this parameter to increase the output frequency with a digital input signal. The motor potentiometer reference INCREASES until the contact is open.

**P3.5.1.25 MOTOR POTENTIOMETER DOWN (ID 417)**

Use this parameter to decrease the output frequency with a digital input signal. The motor potentiometer reference DECREASES until the contact is open.

**P3.5.1.26 QUICK STOP ACTIVATION (ID 1213)**

Use this parameter to select the digital input signal that activates a Quick Stop function. The Quick Stop function stops the drive regardless of the control place or the state of the control signals.

**P3.5.1.27 TIMER 1 (ID 447)**

Use this parameter to select the digital input signal that starts the timer. The timer starts when this signal is deactivated (falling edge). The output is deactivated when the time defined in the duration parameter has elapsed.

**P3.5.1.28 TIMER 2 (ID 448)**

Use this parameter to select the digital input signal that starts the timer. The timer starts when this signal is deactivated (falling edge). The output is deactivated when the time defined in the duration parameter has elapsed.

**P3.5.1.29 TIMER 3 (ID 449)**

Use this parameter to select the digital input signal that starts the timer. The timer starts when this signal is deactivated (falling edge). The output is deactivated when the time defined in the duration parameter has elapsed.

**P3.5.1.30 PID1 SETPOINT BOOST (ID 1046)**

Use this parameter to select the digital input signal that activates the boost for the PID setpoint value. The timer starts when this signal is deactivated (falling edge). The output is deactivated when the time defined in the duration parameter has elapsed.

**P3.5.1.31 PID1 SELECT SETPOINT (ID 1047)**

Use this parameter to set the digital input signal that selects the PID setpoint value to be used.

**P3.5.1.32 EXTERNAL PID START SIGNAL (ID 1049)**

Use this parameter to select the digital input signal that starts and stops the external PID controller.

**NOTE!**

This parameter has no effect if the external PID controller is not enabled in Group 3.14.

***P3.5.1.33 EXTERNAL PID SELECT STARTPOINT (ID 1048)***

Use this parameter to set the digital input signal that selects the PID setpoint value to be used.

***P3.5.1.34 MOTOR 1 INTERLOCK (ID 426)***

Use this parameter to select the digital input signal that is used as interlock signal for the Multi-Pump system.

***P3.5.1.35 MOTOR 2 INTERLOCK (ID 427)***

Use this parameter to select the digital input signal that is used as interlock signal for the Multi-Pump system.

***P3.5.1.36 MOTOR 3 INTERLOCK (ID 428)***

Use this parameter to select the digital input signal that is used as interlock signal for the Multi-Pump system.

***P3.5.1.37 MOTOR 4 INTERLOCK (ID 429)***

Use this parameter to select the digital input signal that is used as interlock signal for the Multi-Pump system.

***P3.5.1.38 MOTOR 5 INTERLOCK (ID 430)***

Use this parameter to select the digital input signal that is used as interlock signal for the Multi-Pump system.

***P3.5.1.39 MOTOR 6 INTERLOCK (ID 486)***

Use this parameter to select the digital input signal that is used as interlock signal for the Multi-Pump system.

***P3.5.1.40 RESET MAINTENANCE COUNTER (ID 490)***

Use this parameter to select the digital input that reset the value of the Maintenance Counter.

***P3.5.1.41 ENABLE DI JOGGING (ID 532)***

Use this parameter to enable the jogging commands from digital inputs. This parameter has no effect on the jogging from fieldbus.

***P3.5.1.42 JOGGING REFERENCE 1 ACTIVATION (ID 530)***

Use this parameter to set the digital input signals that activate the Jogging function.

**NOTE!**

If the input is activated, the drive starts.

***P3.5.1.43 JOGGING REFERENCE 2 ACTIVATION (ID 531)***

Use this parameter to set the digital input signals that activate the Jogging function.

**NOTE!**

If the input is activated, the drive starts.

***P3.5.1.44 MECHANICAL BRAKE FEEDBACK (ID 1210)***

Use this parameter to set the brake status feedback signal from mechanical brake. Connect this input signal to the auxiliary contact of the mechanical brake. If the contact is not closed within the given time, the drive shows a fault.

***P3.5.1.45 FIRE MODE ACTIVATION OPEN (ID 1596)***

Use this parameter to select the digital input signal that activates the Fire Mode function. This parameter activates the Fire Mode if it is enabled with a correct password.

***P3.5.1.46 FIRE MODE ACTIVATION CLOSE (ID 1619)***

Use this parameter to select the digital input signal that activates the Fire Mode function. This parameter activates the Fire Mode if it is enabled with a correct password.

***P3.5.1.47 FIRE MODE REVERSE (ID 1618)***

Use this parameter to select the digital input signal that gives a command for reverse rotation direction during the Fire Mode. This function has no effect in normal operation.

***P3.5.1.48 AUTO-CLEANING ACTIVATION (ID 1715)***

Use this parameter to select the digital input signal that starts the Auto-cleaning. The Auto-cleaning stops if the activation signal is removed before the process is complete.

**NOTE!**

If the input is activated, the drive starts.

***P3.5.1.49 PARAMETER SET 1/2 SELECTION (ID 496)***

Use this parameter to set the digital input that selects the parameter set to be used. This function is enabled if any other slot than 'DigIN Slot0' is selected to this parameter. The parameter set selection is allowed only when the drive is stopped.

Contact Open = Parameter Set 1 is loaded as the active set  
Contact Closed = Parameter Set 2 is loaded as the active set

**NOTE!**

Parameter values are stored to Set 1 and Set 2 by parameters B6.5.4 Save to Set 1 and B6.5.4 Save to Set 2. These parameters can be used either from keypad or Vacon Live pc-tool.

***P3.5.1.50 (P3.9.9.1) USER DEFINED FAULT 1 ACTIVATION (ID 15523)***

Use this parameter to set the digital input signal that activates User Defined Fault 1 (Fault ID 1114).

***P3.5.1.51 (P3.9.10.1) USER DEFINED FAULT 2 ACTIVATION (ID 15524)***

Use this parameter to set the digital input signal that activates User Defined Fault 2 (Fault ID 1115).

**10.6.4 ANALOGUE INPUTS*****P3.5.2.1.1 AI1 SIGNAL SELECTION (ID 377)***

Use this parameter to connect the AI signal to the analogue input of your choice. This parameter is programmable. See *Table 121 Default functions of the programmable digital and analogue inputs*.

***P3.5.2.1.2 AI1 SIGNAL FILTER TIME (ID 378)***

Use this parameter to filter out disturbances in the analogue input signal. To activate this parameter, enter a value greater than 0.

**NOTE!**

A long filter time makes the regulation response slow.

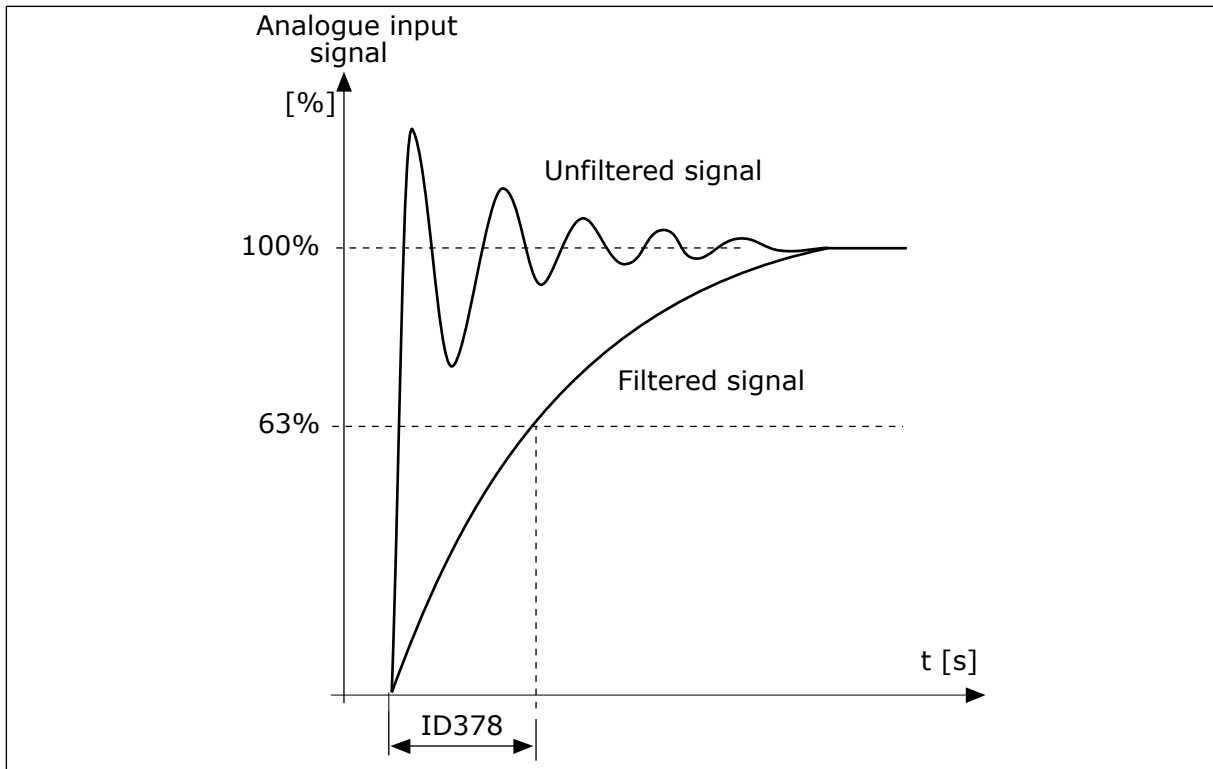

Fig. 47: The AI1 signal filtering

**P3.5.2.1.3 AI1 SIGNAL RANGE (ID 379)**

Use this parameter to change the range of the analogue signal. The value of this parameter is bypassed if the custom scaling parameters are used.

Use the dip switches on the control board to set the type of the analogue input signal (current or voltage). For more information, see the Installation manual.

It is also possible to use the analogue input signal as frequency reference. The selection of the value 0 or 1 change the scaling of the analogue input signal.

Selection number	Selection name	Description
0	0...10V / 0...20mA	The range of the analogue input signal is 0...10V or 0...20mA (the dip switch settings on the control board tell which one). The input signal is 0...100%.



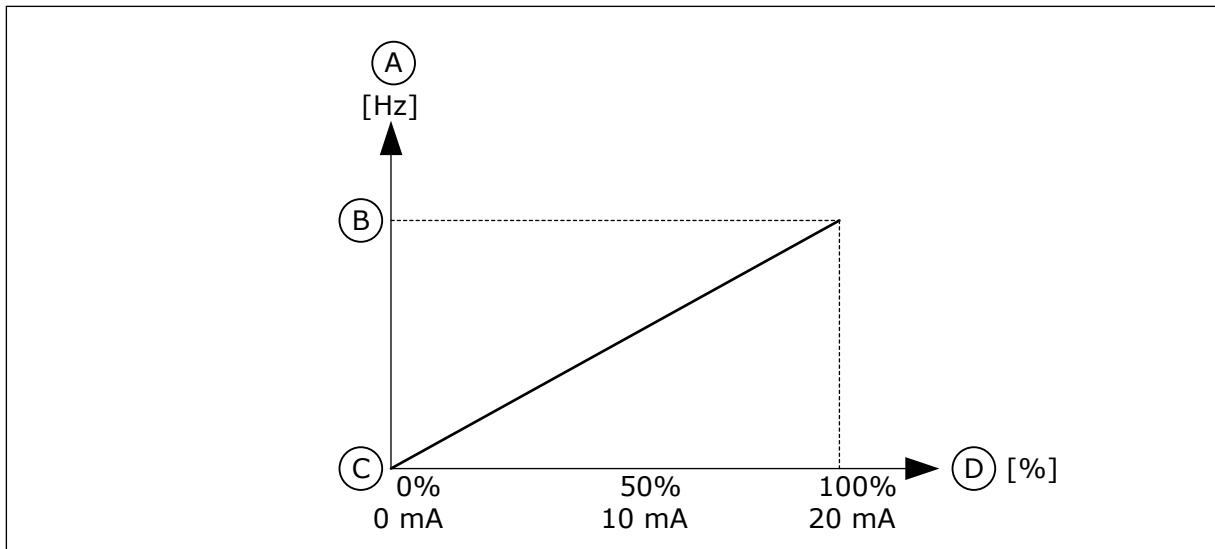

Fig. 48: The analogue input signal range, selection 0

- A. Frequency reference
- B. Max freq reference
- C. Min freq reference
- D. Analogue input signal

Selection number	Selection name	Description
1	2...10V / 4...20mA	The range of the analogue input signal is 2...10V or 4...20mA (the dip switch settings on the control board tell which one). The input signal is 20...100%.

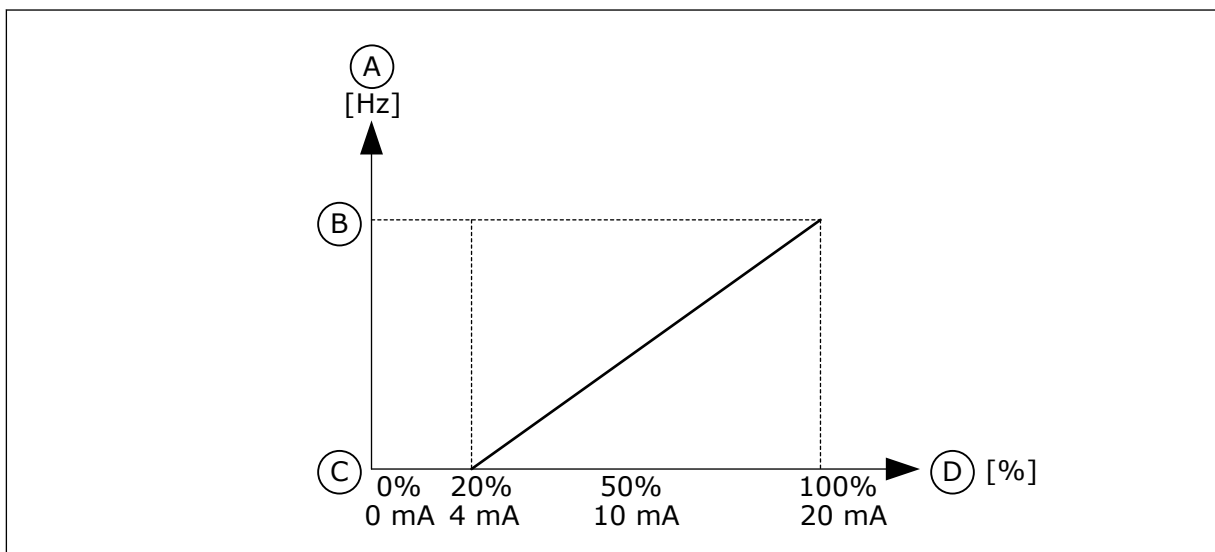

Fig. 49: The analogue input signal range, selection 1

- A. Frequency reference
- B. Max freq reference
- C. Min freq reference
- D. Analogue input signal

**P3.5.2.1.4 AI1 CUSTOM. MIN (ID 380)**

Use this parameter to adjust the range of the analogue input signal between -160% and 160%.

**P3.5.2.1.5 AI1 CUSTOM. MAX (ID 381)**

Use this parameter to adjust the range of the analogue input signal between -160% and 160%.

For example, you can use the analogue input signal as frequency reference, and set the parameters P3.5.2.1.4 and P3.5.2.1.5 between 40 and 80%. In these conditions, the frequency reference changes between the Minimum frequency reference and the Maximum frequency reference, and the analogue input signal changes between 8 and 16 mA.

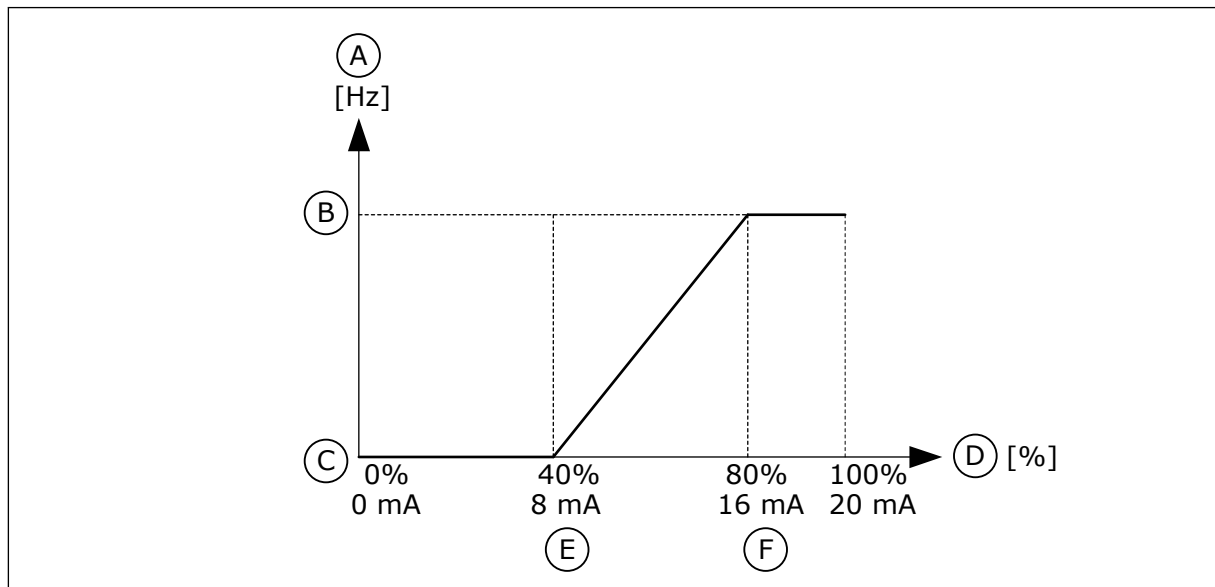

Fig. 50: AI1 signal custom. min/max

- A. Frequency reference
- B. Max freq reference
- C. Min freq reference
- D. Analogue input signal
- E. AI custom min
- F. AI custom max

**P3.5.2.1.6 AI1 SIGNAL INVERSION (ID 387)**

Use this parameter to invert the analogue input signal. When the analogue input signal is inverted, the curve of the signal becomes the opposite.

It is possible to use the analogue input signal as frequency reference. The selection of the value 0 or 1 change scaling of the analogue input signal.

Selection number	Selection name	Description
0	Normal	No inversion. The value 0% of the analogue input signal agrees to the Minimum Frequency Reference. The value 100% of the the analogue input signal agrees to the Maximum Frequency Reference.

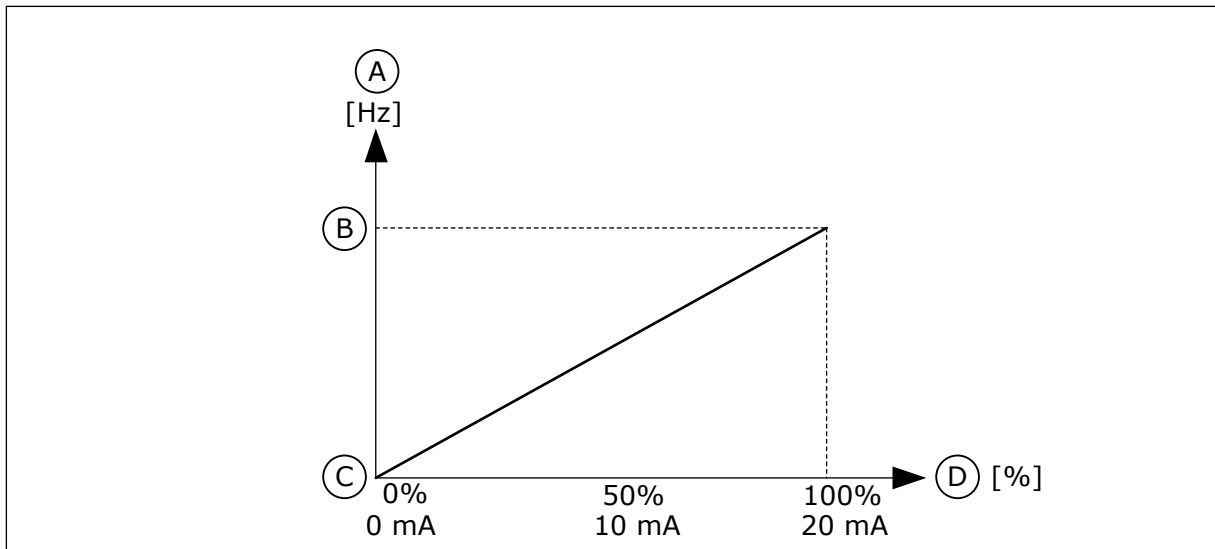

Fig. 51: AI1 signal inversion, selection 0

- A. Frequency reference
- B. Max freq reference
- C. Min freq reference
- D. Analogue input signal

Selection number	Selection name	Description
1	Inverted	Signal inversion. The value 0% of the analogue input signal agrees to the Maximum Frequency Reference. The value 100% of the analogue input signal agrees to the Minimum Frequency Reference.

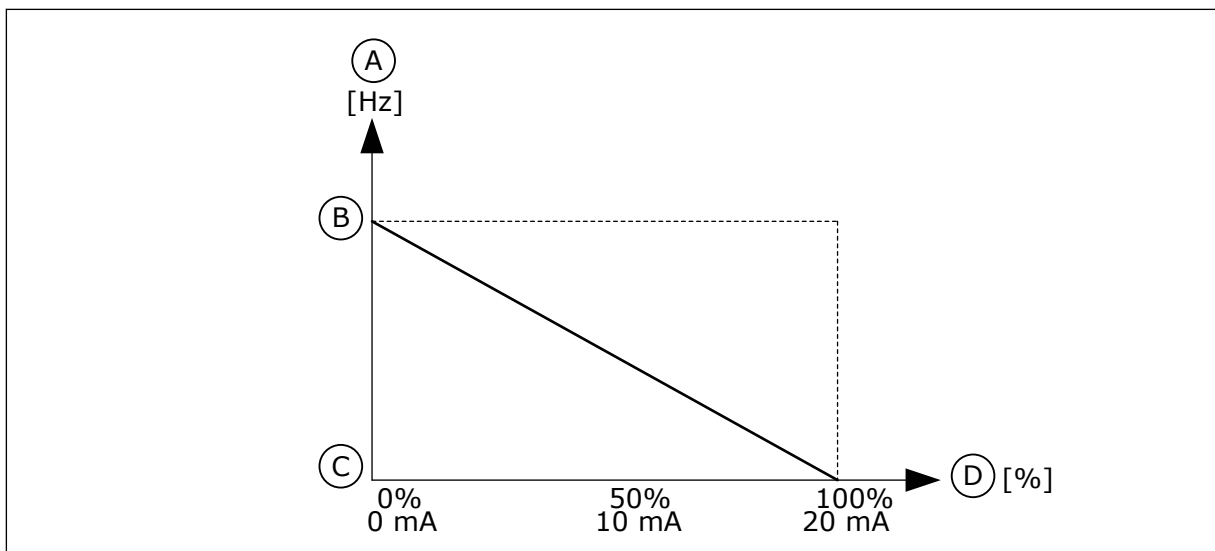

Fig. 52: AI1 signal inversion, selection 1

- A. Frequency reference
- B. Max freq reference
- C. Min freq reference
- D. Analogue input signal

## 10.6.5 DIGITAL OUTPUTS

### ***P3.5.3.2.1 BASIC R01 FUNCTION (ID 11001)***

Use this parameter to select a function or a signal that is connected to the relay output.

**Table 122: The output signals through R01**

Selection number	Selection name	Description
0	Not used	The output is not used.
1	Ready	The AC drive is ready to operate.
2	Run	The AC drive operates (the motor runs).
3	General fault	A fault trip occurred.
4	General fault inverted	A fault trip did <b>not</b> occur.
5	General alarm	An alarm occurred.
6	Reversed	The reverse command is given.
7	At speed	The output frequency has become the same as the set frequency reference.
8	Thermistor fault	A thermistor fault occurred.
9	Motor regulator activated	One of the limit regulators (for example current limit or torque limit) is activated.
10	Start signal active	The start command of the drive is active.
11	Keypad control active	The selection is keypad control (the active control place is keypad).
12	I/O control B active	The selection is I/O control place B (the active control place is I/O B).
13	Limit supervision 1	The limit supervision activates if the signal value goes below or above the set supervision limit (P3.8.3 or P3.8.7).
14	Limit supervision 2	
15	Fire mode active	The Fire mode function is active.
16	Jogging active	The Jogging function is active.
17	Preset Frequency active	The selection of preset frequency was made with digital input signals.
18	Quick Stop active	The Quick stop function is activated.
19	PID in Sleep mode	The PID controller is in the sleep mode.
20	PID Soft Fill activated	The Soft fill function of the PID controller is activated.
21	PID feedback supervision	The feedback value of the PID controller is not in the supervision limits.
22	ExtPID feedback supervision	The External PID controller feedback value is not in the supervision limits.

**Table 122: The output signals through R01**

Selection number	Selection name	Description
23	Input pressure alarm	The input pressure of the pump is below the value that was set with parameter P3.13.9.7.
24	Frost protection alarm	The measured temperature of the pump is below the level that was set with parameter P3.13.10.5.
25	Motor 1 control	The contactor control for the Multi-pump function.
26	Motor 2 control	The contactor control for the Multi-pump function.
27	Motor 3 control	The contactor control for the Multi-pump function.
28	Motor 4 control	The contactor control for the Multi-pump function.
29	Motor 5 control	The contactor control for the Multi-pump function.
30	Motor 6 control	The contactor control for the Multi-pump function.
31	Time channel 1	The status of Time channel 1.
32	Time channel 2	The status of Time channel 2.
33	Time channel 3	The status of Time channel 3.
34	Fieldbus Control Word bit 13	The digital (relay) output control from the Fieldbus control word bit 13.
35	Fieldbus Control Word bit 14	The digital (relay) output control from the Fieldbus control word bit 14.
36	Fieldbus Control Word bit 15	The digital (relay) output control from the Fieldbus control word bit 15.
37	Fieldbus Process Data In1 bit 0	The digital (relay) output control from the Fieldbus Process Data In1, bit 0.
38	Fieldbus Process Data In1 bit 1	The digital (relay) output control from the Fieldbus Process Data In1, bit 1.
39	Fieldbus Process Data In1 bit 2	The digital (relay) output control from the Fieldbus Process Data In1, bit 2.
40	Maintenance counter 1 alarm	The maintenance counter reached the alarm limit that is set with parameter P3.16.2.
41	Maintenance counter 1 fault	The maintenance counter reached the alarm limit that is set with parameter P3.16.3.
42	Mechanical brake control	The Open mechanical brake command.
43	Mechanical brake control (Inverted)	The Open mechanical brake command (inverted).

**Table 122: The output signals through R01**

Selection number	Selection name	Description
44	Block Out.1	The output of the programmable Block 1. See parameter menu M3.19 Drive customizer.
45	Block Out.2	The output of the programmable Block 2. See parameter menu M3.19 Drive customizer.
46	Block Out.3	The output of the programmable Block 3. See parameter menu M3.19 Drive customizer.
47	Block Out.4	The output of the programmable Block 4. See parameter menu M3.19 Drive customizer.
48	Block Out.5	The output of the programmable Block 5. See parameter menu M3.19 Drive customizer.
49	Block Out.6	The output of the programmable Block 6. See parameter menu M3.19 Drive customizer.
50	Block Out.7	The output of the programmable Block 7. See parameter menu M3.19 Drive customizer.
51	Block Out.8	The output of the programmable Block 8. See parameter menu M3.19 Drive customizer.
52	Block Out.9	The output of the programmable Block 9. See parameter menu M3.19 Drive customizer.
53	Block Out.10	The output of the programmable Block 10. See parameter menu M3.19 Drive customizer.
54	Jockey pump control	The control signal for the external jockey pump.
55	Priming pump control	The control signal for the external priming pump.
56	Auto-cleaning active	The Pump auto-cleaning function is activated.
57	Motor Switch Open	The Motor Switch function has detected that the switch between the drive and the motor is open.
58	TEST (Always Closed)	
59	Motor preheat active	

**P3.5.3.2.2 BASIC R01 ON DELAY (ID 11002)**

Use this parameter to set the ON delay for the relay output.

**P3.5.3.2.3 BASIC R01 OFF DELAY (ID 11003)**

Use this parameter to set the OFF delay for the relay output.

## 10.6.6 ANALOGUE OUTPUTS

### ***P3.5.4.1.1 A01 FUNCTION (ID 10050)***

Use this parameter to select a function or a signal that is connected to the analogue output. The contents of the analogue output signal 1 are specified in this parameter. The scaling of the analogue output signal depends on the signal.



Selection number	Selection name	Description
0	Test 0% (Not used)	The analogue output is set to 0% or 20% so that it agrees with parameter P3.5.4.1.3.
1	TEST 100%	The analogue output is set to 100% of the signal (10V / 20mA).
2	Output frequency	The actual output frequency from 0 to Maximum frequency reference.
3	Frequency reference	The actual frequency reference from 0 to Maximum frequency reference.
4	Motor speed	The actual motor speed from 0 to Motor nominal speed.
5	Output current	The output current of the drive from 0 to Motor nominal current.
6	Motor torque	The actual motor torque from 0 to motor nominal torque (100%).
7	Motor power	The actual motor power from 0 to Motor nominal power (100%).
8	Motor voltage	The actual motor voltage from 0 to Motor nominal voltage.
9	DC-link voltage	The actual DC-link voltage 0...1000V.
10	PID Setpoint	The actual setpoint value of the PID Controller (0...100%).
11	PID Feedback	The actual feedback value of the PID Controller (0...100%).
12	PID output	The output of the PID controller (0...100%).
13	ExtPID output	The External PID controller output (0...100%).
14	Fieldbus Process Data In 1	Fieldbus Process Data In 1: 0...10000 (this agrees with 0...100.00%).
15	Fieldbus Process Data In 2	Fieldbus Process Data In 2: 0...10000 (this agrees with 0...100.00%).
16	Fieldbus Process Data In 3	Fieldbus Process Data In 3: 0...10000 (this agrees with 0...100.00%).
17	Fieldbus Process Data In 4	Fieldbus Process Data In 4: 0...10000 (this agrees with 0...100.00%).
18	Fieldbus Process Data In 5	Fieldbus Process Data In 5: 0...10000 (this agrees with 0...100.00%).
19	Fieldbus Process Data In 6	Fieldbus Process Data In 6: 0...10000 (this agrees with 0...100.00%).
20	Fieldbus Process Data In 7	Fieldbus Process Data In 7: 0...10000 (this agrees with 0...100.00%).

Selection number	Selection name	Description
21	Fieldbus Process Data In 8	Fieldbus Process Data In 8: 0...10000 (this agrees with 0...100.00%).
22	Block Out.1	The output of the programmable Block 1: 0...10000 (this agrees with 0...100.00%). See parameter menu M3.19 Drive customizer.
23	Block Out.2	The output of the programmable Block 2: 0...10000 (this agrees with 0...100.00%). See parameter menu M3.19 Drive customizer.
24	Block Out.3	The output of the programmable Block 3: 0...10000 (this agrees with 0...100.00%). See parameter menu M3.19 Drive customizer.
25	Block Out.4	The output of the programmable Block 4: 0...10000 (this agrees with 0...100.00%). See parameter menu M3.19 Drive customizer.
26	Block Out.5	The output of the programmable Block 5: 0...10000 (this agrees with 0...100.00%). See parameter menu M3.19 Drive customizer.
27	Block Out.6	The output of the programmable Block 6: 0...10000 (this agrees with 0...100.00%). See parameter menu M3.19 Drive customizer.
28	Block Out.7	The output of the programmable Block 7: 0...10000 (this agrees with 0...100.00%). See parameter menu M3.19 Drive customizer.
29	Block Out.8	The output of the programmable Block 8: 0...10000 (this agrees with 0...100.00%). See parameter menu M3.19 Drive customizer.
30	Block Out.9	The output of the programmable Block 9: 0...10000 (this agrees with 0...100.00%). See parameter menu M3.19 Drive customizer.
31	Block Out.10	The output of the programmable Block 10: 0...10000 (this agrees with 0...100.00%). See parameter menu M3.19 Drive customizer.

#### ***P3.5.4.1.2 A01 FILTER TIME (ID 10051)***

Use this parameter to set the filtering time for the analog signal.  
The filtering function is disabled when the filtering time is 0. See P3.5.2.1.2.

#### ***P3.5.4.1.3 A01 MINIMUM (ID 10052)***

Use this parameter to change the range of the analogue output signal.  
For example, if '4mA' is selected, the range of analogue output signal is 4..20mA.  
Select the signal type (current/voltage) with the dip switches. The analogue output scaling is different in P3.5.4.1.4. See also P3.5.2.1.3.

**P3.5.4.1.4 A01 MINIMUM SCALE (ID 10053)**

Use this parameter to scale the analogue output signal.  
The scaling values (min and max) are given in the process unit that is specified by the selection of the AO function.

**P3.5.4.1.5 A01 MAXIMUM SCALE (ID 10054)**

Use this parameter to scale the analogue output signal.  
The scaling values (min and max) are given in the process unit that is specified by the selection of the AO function.

For example, you can make a selection of the output frequency of the drive for the contents of the analogue output signal, and set parameters P3.5.4.1.4 and P3.5.4.1.5 between 10 and 40 Hz. Then the output frequency of the drive changes between 10 and 40 Hz, and the analogue output signal changes between 0 and 20 mA.

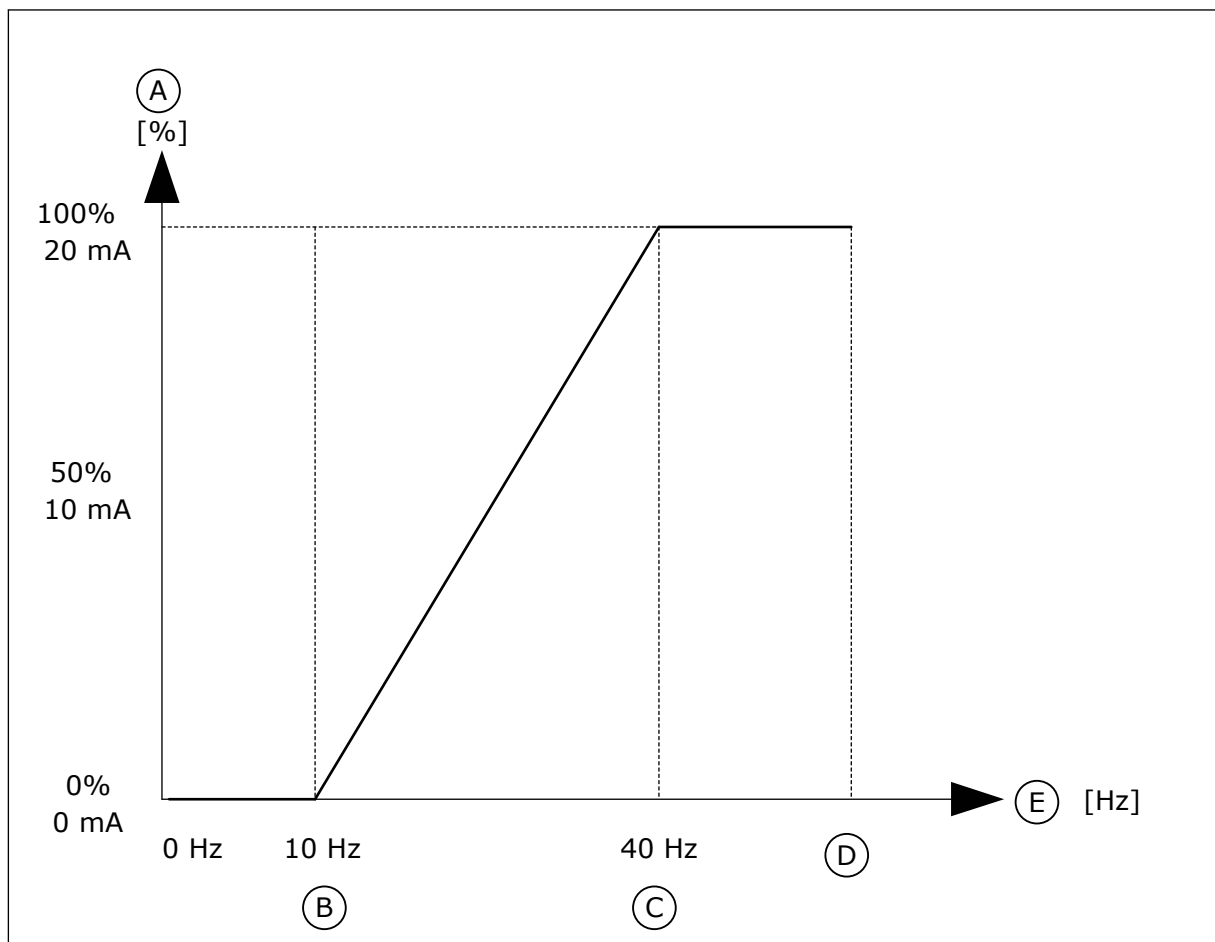

Fig. 53: The scaling of the A01 signal

- |                           |                       |
|---------------------------|-----------------------|
| A. Analogue output signal | D. Max freq reference |
| B. AO min scale           | E. Output frequency   |
| C. AO max scale           |                       |

## 10.7     FIELD BUS DATA MAP

### ***P3.6.1 FB DATAOUT 1 SEL (ID 852)***

Use this parameter to select the data that is sent to the fieldbus with the ID number of the parameter or monitor value.

The data is scaled to an unsigned 16-bit format according to the format on the control panel. For example, value 25.5 on the display equals 255.

### ***P3.6.2 FB DATAOUT 2 SEL (ID 853)***

Use this parameter to select the data that is sent to the fieldbus with the ID number of the parameter or monitor value.

The data is scaled to an unsigned 16-bit format according to the format on the control panel. For example, value 25.5 on the display equals 255.

### ***P3.6.3 FB DATAOUT 3 SEL (ID 854)***

Use this parameter to select the data that is sent to the fieldbus with the ID number of the parameter or monitor value.

The data is scaled to an unsigned 16-bit format according to the format on the control panel. For example, value 25.5 on the display equals 255.

### ***P3.6.4 FB DATAOUT 4 SEL (ID 855)***

Use this parameter to select the data that is sent to the fieldbus with the ID number of the parameter or monitor value.

The data is scaled to an unsigned 16-bit format according to the format on the control panel. For example, value 25.5 on the display equals 255.

### ***P3.6.5 FB DATAOUT 5 SEL (ID 856)***

Use this parameter to select the data that is sent to the fieldbus with the ID number of the parameter or monitor value.

The data is scaled to an unsigned 16-bit format according to the format on the control panel. For example, value 25.5 on the display equals 255.

### ***P3.6.6 FB DATAOUT 6 SEL (ID 857)***

Use this parameter to select the data that is sent to the fieldbus with the ID number of the parameter or monitor value.

The data is scaled to an unsigned 16-bit format according to the format on the control panel. For example, value 25.5 on the display equals 255.

### ***P3.6.7 FB DATAOUT 7 SEL (ID 858)***

Use this parameter to select the data that is sent to the fieldbus with the ID number of the parameter or monitor value.

The data is scaled to an unsigned 16-bit format according to the format on the control panel. For example, value 25.5 on the display equals 255.

**P3.6.8 FB DATAOUT 8 SEL (ID 859)**

Use this parameter to select the data that is sent to the fieldbus with the ID number of the parameter or monitor value.

The data is scaled to an unsigned 16-bit format according to the format on the control panel. For example, value 25.5 on the display equals 255.

**10.8 PROHIBIT FREQUENCIES**

In some processes it can be necessary to avoid some frequencies because they make problems of mechanical resonance. With the Prohibit frequencies function, it is possible to prevent the usage of these frequencies. When the input frequency reference increases, the internal frequency reference stays at the low limit, until the input frequency reference is above the high limit.

**P3.7.1 PROHIBIT FREQUENCY RANGE 1 LOW LIMIT (ID 509)**

Use this parameter to prevent the drive operating on the prohibited frequencies. In some processes it can be necessary to avoid some frequencies because they cause mechanical resonance.

**P3.7.2 PROHIBIT FREQUENCY RANGE 1 HIGH LIMIT (ID 510)**

Use this parameter to prevent the drive operating on the prohibited frequencies. In some processes it can be necessary to avoid some frequencies because they cause mechanical resonance.

**P3.7.3 PROHIBIT FREQUENCY RANGE 2 LOW LIMIT (ID 511)**

Use this parameter to prevent the drive operating on the prohibited frequencies. In some processes it can be necessary to avoid some frequencies because they cause mechanical resonance.

**P3.7.4 PROHIBIT FREQUENCY RANGE 2 HIGH LIMIT (ID 512)**

Use this parameter to prevent the drive operating on the prohibited frequencies. In some processes it can be necessary to avoid some frequencies because they cause mechanical resonance.

**P3.7.5 PROHIBIT FREQUENCY RANGE 3 LOW LIMIT (ID 513)**

Use this parameter to prevent the drive operating on the prohibited frequencies. In some processes it can be necessary to avoid some frequencies because they cause mechanical resonance.

**P3.7.6 PROHIBIT FREQUENCY RANGE 3 HIGH LIMIT (ID 514)**

Use this parameter to prevent the drive operating on the prohibited frequencies. In some processes it can be necessary to avoid some frequencies because they cause mechanical resonance.

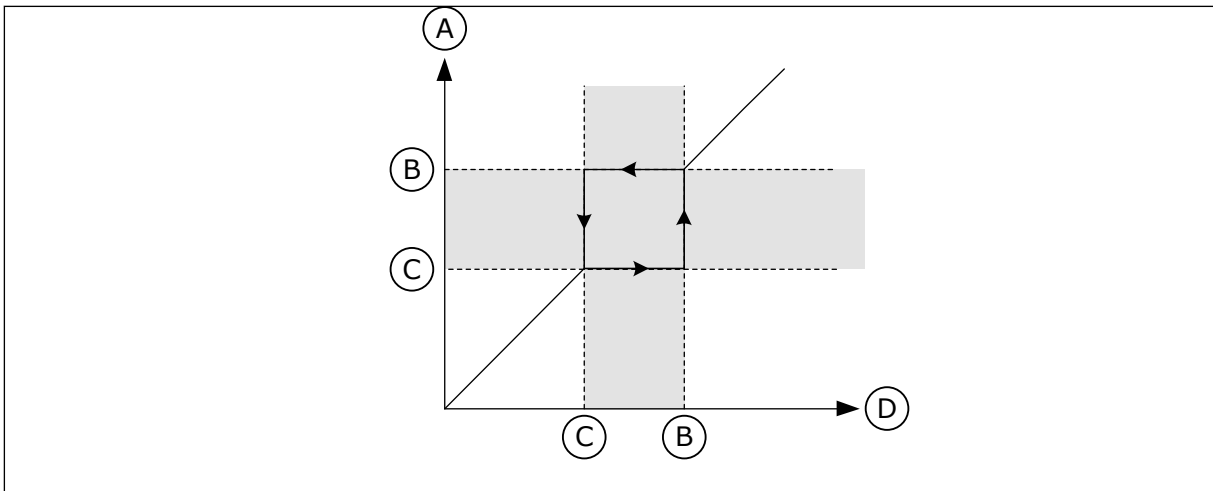

Fig. 54: The prohibited frequencies

- A. Actual Reference
- B. High Lim
- C. Low lim
- D. Requested Reference

**P3.7.7 RAMP TIME FACTOR (ID 518)**

Use this parameter to set the multiplier of the selected ramp times when the output frequency of the drive is between the prohibited frequency limits. The Ramp Time Factor sets the acceleration and the deceleration time when the output frequency is in a prohibited frequency range. The value of the Ramp Time Factor is multiplied with the value of P3.4.1.2 (Acceleration Time 1) or P3.4.1.3 (Deceleration Time 1). For example, the value 0.1 makes the acceleration/deceleration time ten times shorter.

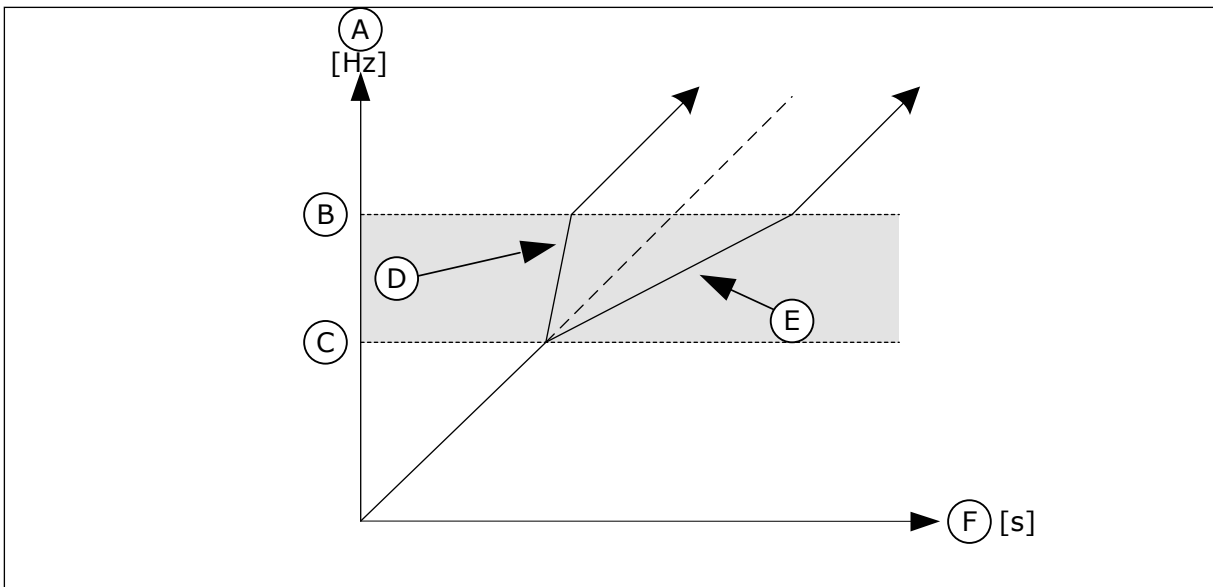

Fig. 55: The parameter Ramp Time Factor

- A. Output Frequency
- B. High Lim
- C. Low Lim
- D. Ramp Time Factor = 0.3
- E. Ramp Time Factor = 2.5
- F. Time

## 10.9 SUPERVISIONS

### ***P3.8.1 SUPERVISION #1 ITEM SELECTION (ID 1431)***

Use this parameter to select the supervision item.  
The output of the supervision function can be selected to the relay output.

### ***P3.8.2 SUPERVISION #1 MODE (ID 1432)***

Use this parameter to set the supervision mode.  
When the 'Low limit' mode is selected, the output of the supervision function is active when the signal is below the supervision limit.  
When the 'High limit' mode is selected, the output of the supervision function is active when the signal is above the supervision limit.

### ***P3.8.3 SUPERVISION #1 LIMIT (ID 1433)***

Use this parameter to set the supervision limit for the selected item.  
The unit shows automatically.

### ***P3.8.4 SUPERVISION #1 LIMIT HYSTERESIS (ID 1434)***

Use this parameter to set the supervision limit hysteresis for the selected item.  
The unit shows automatically.

### ***P3.8.5 SUPERVISION #2 ITEM SELECTION (ID 1435)***

Use this parameter to select the supervision item.  
The output of the supervision function can be selected to the relay output.

### ***P3.8.6 SUPERVISION #2 MODE (ID 1436)***

Use this parameter to set the supervision mode.

### ***P3.8.7 SUPERVISION #2 LIMIT (ID 1437)***

Use this parameter to set the supervision limit for the selected item.  
The unit shows automatically.

### ***P3.8.8 SUPERVISION #2 LIMIT HYSTERESIS (ID 1438)***

Use this parameter to set the supervision limit hysteresis for the selected item.  
The unit shows automatically.

## 10.10 PROTECTIONS

### 10.10.1 GENERAL

#### ***P3.9.1.2 RESPONSE TO EXTERNAL FAULT (ID 701)***

Use this parameter to select the response of the drive to an 'External Fault'.

If a fault occurs, the drive can show a notification of it on the display of the drive. An external fault is activated with a digital input signal. The default digital input is DI3. You can also program the response data into a relay output.

### ***P3.9.1.3 INPUT PHASE FAULT (ID 730)***

Use this parameter to select the supply phase configuration of the drive.



#### **NOTE!**

If you use the 1-phase supply, the value of this parameter must be set to '1-phase support'.

### ***P3.9.1.4 UNDERVOLTAGE FAULT (ID 727)***

Use this parameter to select if undervoltage faults are saved to the fault history or not.

### ***P3.9.1.5 RESPONSE TO OUTPUT PHASE FAULT (ID 702)***

Use this parameter to select the response of the drive to an 'Output Phase' fault. If the measurement of the motor current detects that there is no current in 1 motor phase, an output phase fault occurs.  
See P3.9.1.2.

### ***P3.9.1.6 RESPONSE TO FIELD BUS COMMUNICATION FAULT (ID 733)***

Use this parameter to select the response of the drive to a 'Fieldbus Timeout' fault. If the data connection between the master and the fieldbus board is defective, a fieldbus fault occurs.

### ***P3.9.1.7 SLOT COMMUNICATION FAULT (ID 734)***

Use this parameter to select the response of the drive to a 'Slot Communication' fault. If the drive detects a defective option board, a slot communication fault occurs.  
See P3.9.1.2.

### ***P3.9.1.8 THERMISTOR FAULT (ID 732)***

Use this parameter to select the response of the drive to a 'Thermistor' fault. If the thermistor detects too high temperature, a thermistor fault occurs.  
See P3.9.1.2.

### ***P3.9.1.9 PID SOFT FILL FAULT (ID 748)***

Use this parameter to select the response of the drive to a 'PID Soft Fill' fault. If the PIDFeedback value does not reach the set level within the time limit, a soft fill fault occurs.  
See P3.9.1.2.

### ***P3.9.1.10 RESPONSE TO PID SUPERVISION FAULT (ID 749)***

Use this parameter to select the response of the drive to a 'PID Supervision' fault.



If the PID feedback value is not within the supervision limits for longer than the supervision delay, a PID supervision fault occurs.  
See P3.9.1.2.

#### **P3.9.1.11 RESPONSE TO EXTERNAL PID SUPERVISION FAULT (ID 757)**

Use this parameter to select the response of the drive to a 'PID Supervision' fault.  
If the PID feedback value is not within the supervision limits for longer than the supervision delay, a PID supervision fault occurs.  
See P3.9.1.2.

#### **P3.9.1.12 EARTH FAULT (ID 703)**

Use this parameter to select the response of the drive to an 'Earth Fault'.  
If the measurement of the current detects that the sum of the motor phase currents is not 0, an earth fault occurs.  
See P3.9.1.2.



#### **NOTE!**

You can configure this fault only in frame sizes MR7, MR8, and MR9.

#### **P3.9.1.13 PRESET ALARM FREQUENCY (ID 183)**

Use this parameter to set the frequency of the drive when a fault is active and the response to the fault is set to 'Alarm + Preset Frequency'.

#### **P3.9.1.14 RESPONSE TO SAFE TORQUE OFF (STO) FAULT (ID 775)**

Use this parameter to select the response of the drive to a 'STO Fault'.

This parameter defines drive operation when Safe Torque Off (STO) function is activated (e.g. emergency stop button has been pressed or some other STO operation has been activated).  
See P3.9.1.2.

### **10.10.2 MOTOR THERMAL PROTECTIONS**

The motor thermal protection prevents the motor from becoming too hot.

The AC drive can supply a current that is higher than the nominal current. The high current can be necessary to the load, and it must be used. In these conditions, there is a risk of a thermal overload. Low frequencies have a higher risk. At low frequencies, the cooling effect and the capacity of the motor decrease. If the motor has an external fan, the load reduction at low frequencies is small.

The motor thermal protection is based on calculations. The protection function uses the output current of the drive to know what is the load on the motor. If the control board is not energised, the calculations are reset.

To adjust the thermal protection of the motor, use the parameters from P3.9.2.1 to P3.9.2.5. You can monitor the thermal status of the motor on the display of the control panel. See Chapter 3 *User interfaces*.

**NOTE!**

If you use long motor cables (max. 100 m) with small drives ( $\leq 1.5$  kW), the motor current that the drive measures can be much higher than the actual motor current. It is because there are capacitive currents in the motor cable.

**CAUTION!**

Make sure that the airflow to the motor is not blocked. If the airflow is blocked, the function does not protect the motor, and the motor can become too hot. This can cause damage to the motor.

***P3.9.2.1 MOTOR THERMAL PROTECTION (ID 704)***

Use this parameter to select the response of the drive to a 'Motor Overtemperature' fault. If the motor thermal protection function detects that the temperature of the motor is too high, a motor overtemperature fault occurs.

**NOTE!**

If you have a motor thermistor, use it to protect the motor. Set the value of this parameter to 0.

***P3.9.2.2 AMBIENT TEMPERATURE (ID 705)***

Use this parameter to set the ambient temperature where the motor is installed. The temperature value is given in celsius or fahrenheit degrees.

***P3.9.2.3 ZERO SPEED COOLING FACTOR (ID 706)***

Use this parameter to set the cooling factor at 0 speed in relation to the point where the motor operates at nominal speed without external cooling.

The default value is set for conditions where there is no external fan. If you use an external fan, you can set the value higher than without the fan, for example at 90%.

If you change parameter P3.1.1.4 (Motor Nominal Current), parameter P3.9.2.3 is automatically set to its default value.

Although you change this parameter, it does not have an effect on the maximum output current of the drive. Only parameter P3.1.3.1 Motor Current Limit can change the maximum output current.

The corner frequency for the thermal protection is 70% of the value of the parameter P3.1.1.2 Motor Nominal Frequency.

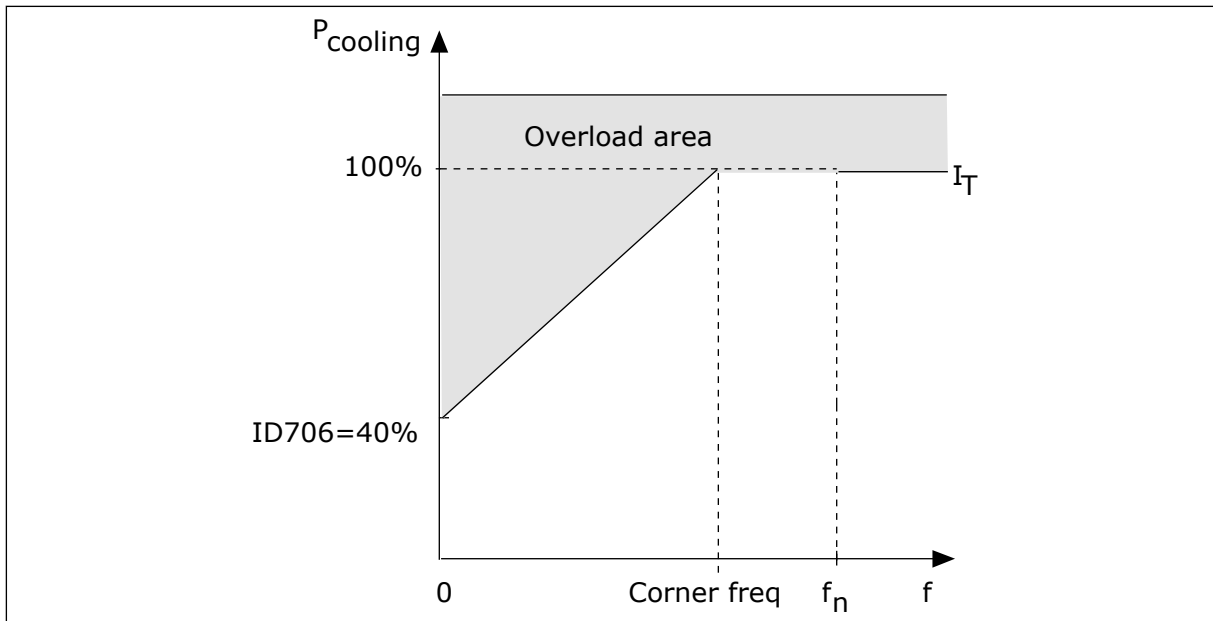

Fig. 56: The motor thermal current  $I_T$  curve

### P3.9.2.4 MOTOR THERMAL TIME CONSTANT (ID 707)

Use this parameter to set the motor thermal time constant.

The time constant is the time within which the calculated thermal stage has reached 63% of its final value. The final thermal stage equals to running the motor continuously with nominal load at nominal speed. The length of the time constant is in relation with the dimension of the motor. The bigger the motor, the longer the time constant.

In different motors, the motor thermal time constant is different. It also changes between different motor manufacturers. The default value of the parameter changes from dimension to dimension.

The  $t_6$ -time is the time in seconds that the motor can safely operate at 6 times the rated current. It is possible that the motor manufacturer gives the data with the motor. If you know the  $t_6$  of the motor, you can set the time constant parameter with its help. Usually, the motor thermal time constant in minutes is  $2 \cdot t_6$ . When the drive is in the STOP state, the time constant is internally increased to 3 times the set parameter value, because the cooling operates based on convection.

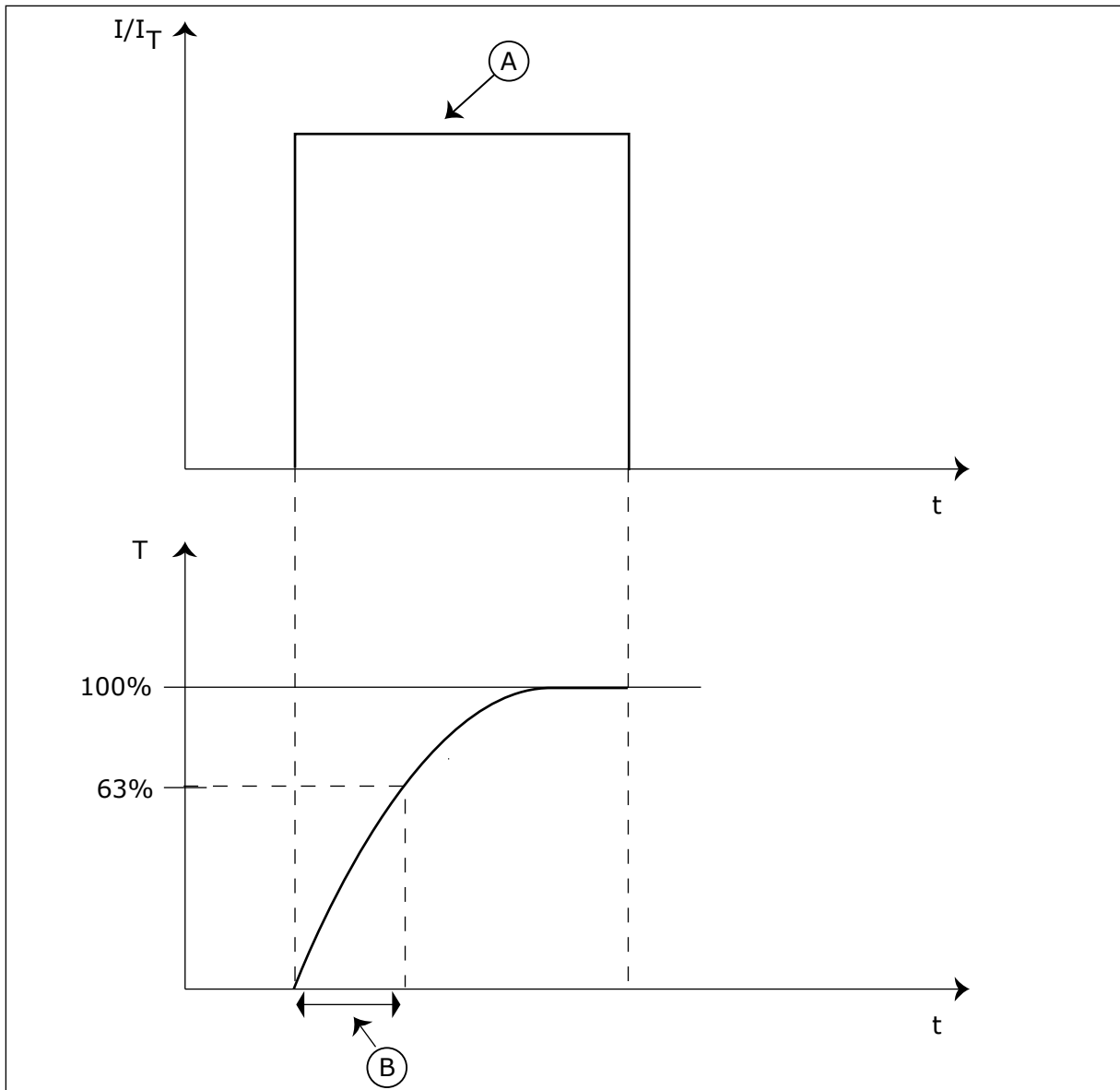

Fig. 57: The motor thermal time constant

A. Current

B.  $T =$  Motor thermal time constant

**P3.9.2.5 MOTOR THERMAL LOADABILITY (ID 708)**

Use this parameter to set the thermal loadability of the motor.  
 For example, if you set the value to 130%, the motor goes to the nominal temperature with 130% of the motor nominal current.

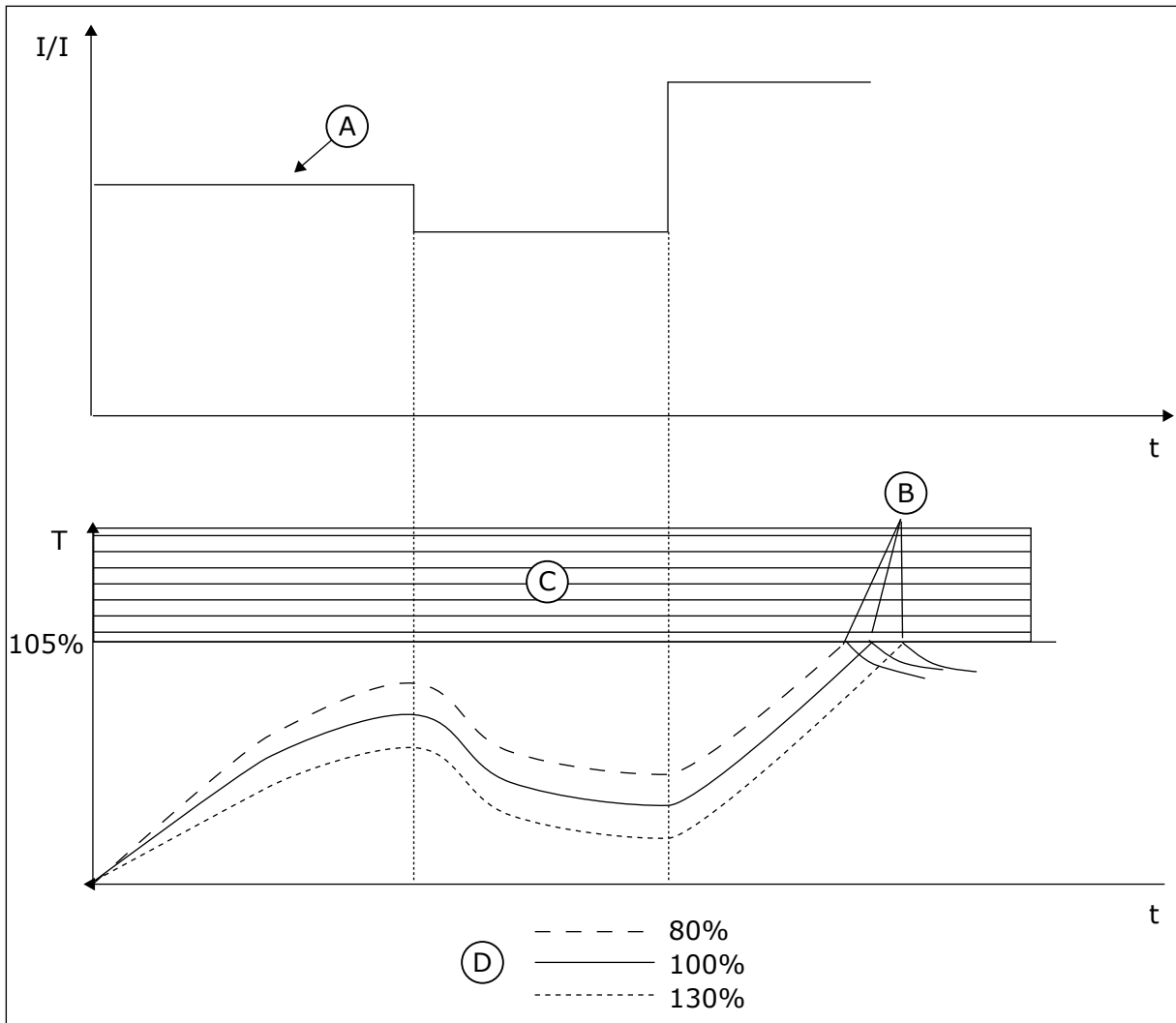

Fig. 58: The calculation of the motor temperature

- A. Current
- B. Fault/Alarm
- C. Trip area
- D. Loadability

### 10.10.3 MOTOR STALL PROTECTION

The motor stall protection function gives protection to the motor against short overloads. An overload can be caused, for example, by a stalled shaft. It is possible to set the reaction time of the stall protection shorter than that of the motor thermal protection.

The stall status of the motor is specified with parameters P3.9.3.2 Stall Current and P3.9.3.4 Stall Frequency Limit. If the current is higher than the limit, and the output frequency is lower than the limit, the motor is in a stall status.

The stall protection is a type of overcurrent protection.



**NOTE!**

If you use long motor cables (max. 100 m) with small drives ( $\leq 1.5$  kW), the motor current that the drive measures can be much higher than the actual motor current. It is because there are capacitive currents in the motor cable.

**P3.9.3.1 MOTOR STALL FAULT (ID 709)**

Use this parameter to select the response of the drive to a 'Motor Stall' fault.  
If the stall protection detects that the shaft of the motor is stalled, a motor stall fault occurs.

**P3.9.3.2 STALL CURRENT (ID 710)**

Use this parameter to set the limit above which the current of the motor must stay for a stall stage to occur.

If the value of the motor current limit parameter changes, this parameter is automatically set to 90 % of the current limit.

You can set the value of this parameter between 0.0 and  $2 \cdot I_L$ . For a stall status to occur, the current must be higher than this limit. If parameter P3.1.3.1 Motor Current Limit changes, this parameter is automatically calculated to 90% of the current limit.

**NOTE!**

The value of the Stall Current must be below the motor current limit.

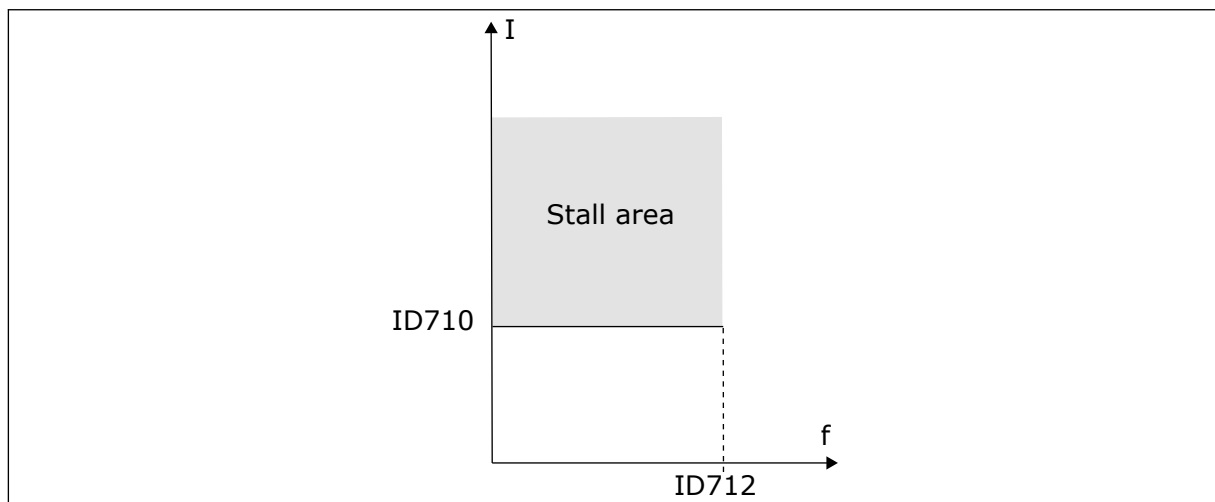

Fig. 59: The stall characteristics settings

**P3.9.3.3 STALL TIME LIMIT (ID 711)**

Use this parameter to set the maximum time for a stall stage.

This is the maximum time for the stall stage to be active before a motor stall fault occurs.

You can set the value of this parameter between 1.0 and 120.0 s. An internal counter counts the stall time.

If the stall time counter value goes above this limit, the protection causes the drive to trip.

**P3.9.3.4 STALL FREQUENCY LIMIT (ID 712)**

Use this parameter to set the limit below which the output frequency of the drive must stay for a stall stage to occur.

**NOTE!**

For a stall state to occur, the output frequency must be below this limit for a certain time.

#### 10.10.4 UNDERLOAD PROTECTION

The motor underload protection makes sure that there is a load on the motor when the drive operates. If the motor loses the load, a problem can occur in the process. For example, a belt can break or a pump become dry.

You can adjust the motor underload protection with parameters P3.9.4.2 (Underload Protection: Field Weakening Area Load) and P3.9.4.3 (Underload Protection: Zero Frequency Load). The underload curve is a squared curve between the zero frequency and the field weakening point. The protection is not active below 5 Hz. The underload time counter does not operate below 5 Hz.

The values of the underload protection parameters are set in percentage of the nominal torque of the motor. To find the scaling ratio for the internal torque value, use the data in the name plate data of the motor, the motor nominal current and the nominal current of the drive IH. If you use another current than the nominal motor current, the precision of the calculation decreases.

**NOTE!**

If you use long motor cables (max. 100 m) with small drives ( $\leq 1.5$  kW), the motor current that the drive measures can be much higher than the actual motor current. It is because there are capacitive currents in the motor cable.

##### ***P3.9.4.1 UNDERLOAD FAULT (ID 713)***

Use this parameter to select the response of the drive to an 'Underload' fault. If the underload protection function detects that there is not a sufficient load on the motor, an underload fault occurs.

##### ***P3.9.4.2 UNDERLOAD PROTECTION: FIELD WEAKENING AREA LOAD (ID 714)***

Use this parameter to set the minimum torque that the motor needs when the output frequency of the drive is higher than the frequency of the weakening point. You can set the value of this parameter between 10.0 and 150.0% x TnMotor. This value is the limit for the minimum torque when the output frequency is above the field weakening point.

If you change parameter P3.1.1.4 (Motor Nominal Current), this parameter goes automatically back to its default value. See *10.10.4 Underload protection*.

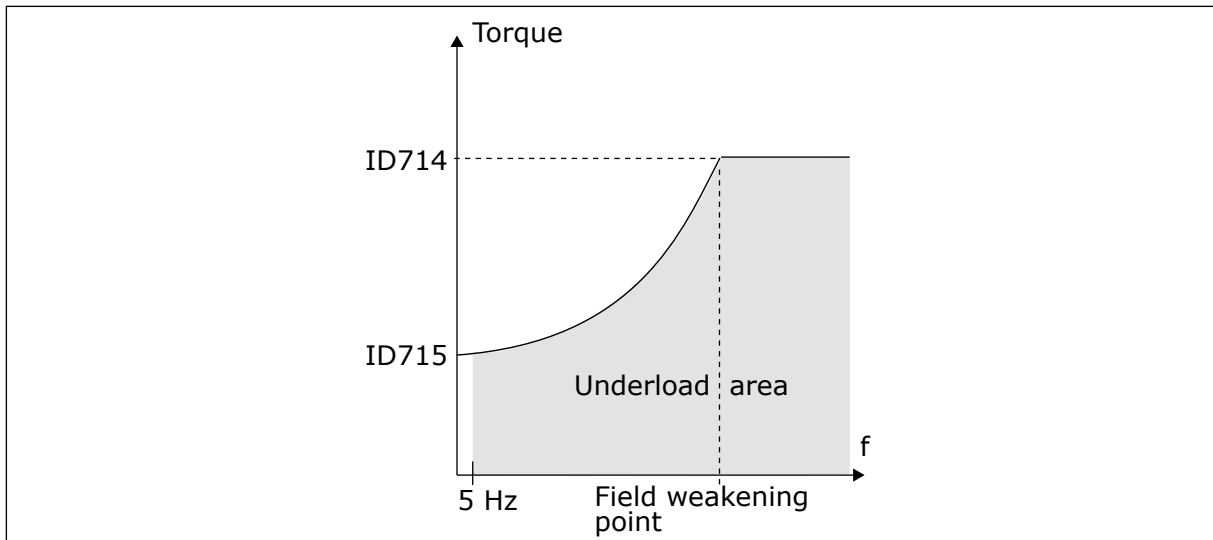

Fig. 60: Setting of the minimum load

### **P3.9.4.3 UNDERLOAD PROTECTION: ZERO FREQUENCY LOAD (ID 715)**

Use this parameter to set the minimum torque that the motor needs when the output frequency of the drive is 0.

If you change the value of parameter P3.1.1.4, this parameter is automatically restored to the default value.

### **P3.9.4.4 UNDERLOAD PROTECTION: TIME LIMIT (ID 716)**

Use this parameter to set the maximum time for an underload state.

This is the maximum time for the underload state to be active before an underload fault occurs.

You can set the time limit between 2.0 and 600.0 s.

An internal counter counts the underload time. If the value of the counter goes above this limit, the protection causes the drive to trip. The drive trips as is set in parameter P3.9.4.1 Underload Fault. If the drive stops, the underload counter goes back to 0.



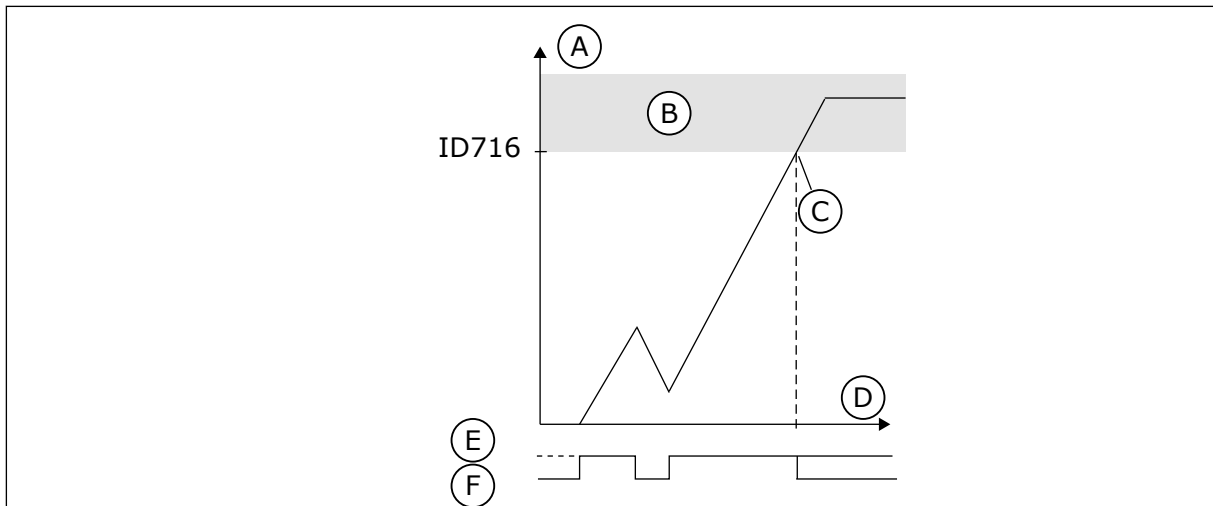

Fig. 61: The Underload time counter function

- |                           |                 |
|---------------------------|-----------------|
| A. Underload time counter | D. Time         |
| B. Trip area              | E. Underload    |
| C. Trip/warning ID713     | F. No underload |

### 10.10.5 QUICK STOP

#### **P3.9.5.1 QUICK STOP MODE (ID 1276)**

Use this parameter to select how the drive stops when the quick stop command is given from DI or Fieldbus.

#### **P3.9.5.2 QUICK STOP ACTIVATION (ID 1213)**

Use this parameter to select the digital input signal that activates a Quick Stop function. The Quick Stop function stops the drive regardless of the control place or the state of the control signals.

#### **P3.9.5.3 QUICK STOP DECELERATION TIME (ID 1256)**

Use this parameter to set the time that is necessary for the output frequency to decrease from maximum frequency to 0 when a quick stop command is given. The value of this parameter is applied only when the quick stop mode parameter is set to 'Quick Stop Deceleration time'.

#### **P3.9.5.4 RESPONSE TO QUICK STOP FAULT (ID 744)**

Use this parameter to select the response of the drive to a 'Quick Stop' fault. If the quick stop command is given from DI or Fieldbus, a quick stop fault occurs.

With the quick stop function, you can stop the drive in an unusual procedure from I/O or Fieldbus in unusual conditions. When the quick stop function is active, you can make the drive decelerate and stop. It is possible to program an alarm or fault to put a mark in the fault history that there was a request for a quick stop.



**CAUTION!**

Do not use the quick stop function as an emergency stop. An emergency stop must stop the power supply to the motor. The quick stop function does not do this.

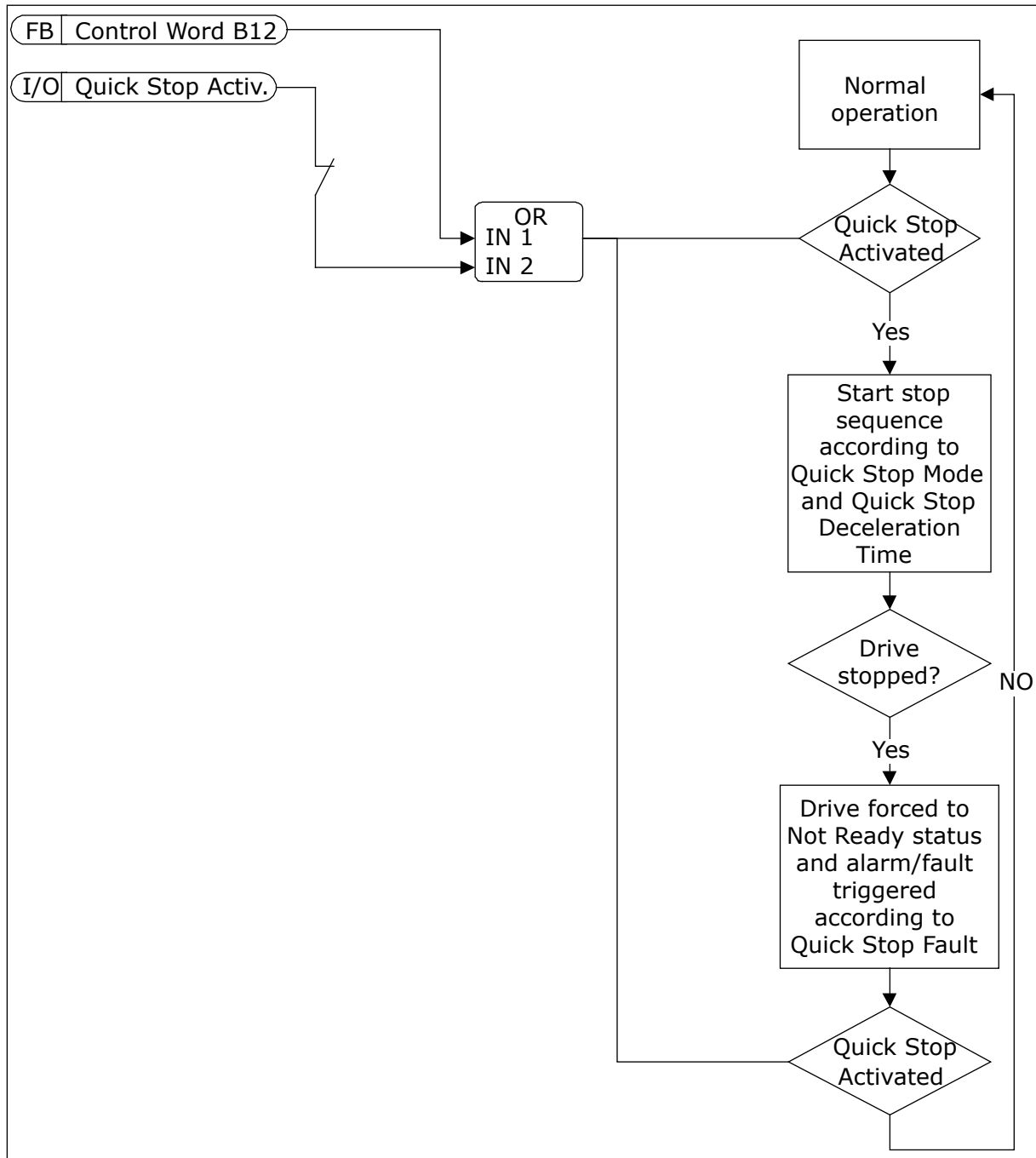

Fig. 62: The quick stop logic

10.10.6 TEMPERATURE INPUT FAULT

**P3.9.6.1 TEMPERATURE SIGNAL 1 (ID 739)**

Use this parameter to select the temperature input signals that are supervised.

The maximum value is taken from the set signals and used for alarm and fault triggering.

**NOTE!**

Only the 6 first temperature inputs are supported (the boards from slot A to slot E).

***P3.9.6.2 ALARM LIMIT 1 (ID 741)***

Use this parameter to set the temperature alarm limit.

Only the inputs that are set with parameter P3.9.6.1 are compared.

***P3.9.6.3 FAULT LIMIT 1 (ID 742)***

Use this parameter to set the temperature fault limit.

Only the inputs that are set with parameter P3.9.6.1 are compared.

***P3.9.6.4 FAULT LIMIT RESPONSE 1 (ID 740)***

Use this parameter to select the response of the drive to 'Temperature' fault.

***P3.9.6.5 TEMPERATURE SIGNAL 2 (ID 763)***

Use this parameter to select the temperature input signals that are supervised.

The maximum value is taken from the set signals and used for alarm and fault triggering.

**NOTE!**

Only the 6 first temperature inputs are supported (the boards from slot A to slot E).

***P3.9.6.6 ALARM LIMIT 2 (ID 764)***

Use this parameter to set the temperature alarm limit.

Only the inputs that are set with parameter P3.9.6.5 are compared.

***P3.9.6.7 FAULT LIMIT 2 (ID 765)***

Use this parameter to set the temperature fault limit.

Only the inputs that are set with parameter P3.9.6.5 are compared.

***P3.9.6.8 FAULT LIMIT RESPONSE 2 (ID 766)***

Use this parameter to select the response of the drive to 'Temperature' fault.

**NOTE!**

Temperature input settings are only available if a B8 or BH option board is installed.

## 10.10.7 AI LOW PROTECTION

### **P3.9.8.1 ANALOGUE INPUT LOW PROTECTION (ID 767)**

Use this parameter to select when the AI Low supervision is enabled. For example, the AI Low supervision can be enabled only when the drive is in run state.

Use the AI Low Protection to find failures in the analogue input signals. This function gives protection only to the analogue inputs that are used as frequency reference, torque reference, or in the PID/ExtPID controllers.

You can have the protection on when the drive is in the RUN status, or in the RUN and STOP statuses.

Selection number	Selection name	Description
1	Protection disabled	
2	Protection enabled in RUN status	The protection is enabled only when the drive is in the RUN status.
3	Protection enabled in RUN and STOP status	The protection is enabled in the 2 statuses, RUN and STOP.

### **P3.9.8.2 ANALOGUE INPUT LOW FAULT (ID 700)**

Use this parameter to select the response of the drive to an 'AI Low' fault. If the analogue input signal becomes less than 50% of the minimum signal for 500ms, an AI Low fault occurs.

If AI Low Protection is enabled with parameter P3.9.8.1, this parameter gives a response for the fault code 50 (Fault ID 1050).

The AI low protection function monitors the signal level of the analogue inputs 1-6. If the analogue input signal becomes less than 50% of the minimum signal for 500 ms, an AI Low fault or alarm shows.



#### **NOTE!**

You can use the value *Alarm + Previous Freq* only when you use analogue input 1 or analogue input 2 as frequency reference.

Selection number	Selection name	Description
0	No Action	AI Low Protection is not used.
1	Alarm	
2	Alarm, preset frequency	The frequency reference is set as in P3.9.1.13 Preset Alarm Frequency.
3	Alarm, previous frequency	The last valid frequency is kept as frequency reference.
4	Fault	The drive stops as is set in P3.2.5 Stop Mode.
5	Fault, coasting	The drive stops by coasting.

## 10.10.8 USER-DEFINED FAULT 1

### ***P3.9.9.1 USER DEFINED FAULT 1 (ID 15523)***

Use this parameter to set the digital input signal that activates User Defined Fault 1 (Fault ID 1114).

### ***P3.9.9.2 RESPONSE TO USER DEFINED FAULT 1 (ID 15525)***

Use this parameter to select the response of the drive to User Defined Fault 1 (Fault ID 1114).

## 10.10.9 USER-DEFINED FAULT 2

### ***P3.9.10.1 USER DEFINED FAULT 2 (ID 15524)***

Use this parameter to set the digital input signal that activates User Defined Fault 2 (Fault ID 1115).

### ***P3.9.10.2 RESPONSE TO USER DEFINED FAULT 2 (ID 15526)***

Use this parameter to select the response of the drive to User Defined Fault 2 (Fault ID 1115).

## 10.11 AUTOMATIC RESET

### ***P3.10.1 AUTOMATIC RESET (ID 731)***

Use this parameter to enable the Automatic reset function.  
To select the faults that are reset automatically, enter the value *0* or *1* to parameters from P3.10.6 to P3.10.13.



#### **NOTE!**

The automatic reset function is available only for some fault types.

**P3.10.2 RESTART FUNCTION (ID 719)**

Use this parameter to select the start mode for the Automatic reset function.

**P3.10.3 WAIT TIME (ID 717)**

Use this parameter to set the wait time before the first reset is done.

**P3.10.4 TRIAL TIME (ID 718)**

Use this parameter to set the trial time for the automatic reset function.

During the trial time, the automatic reset function tries to reset the faults that occur. The time count starts from the first automatic reset. The next fault starts the trial time count again.

**P3.10.5 NUMBER OF TRIALS (ID 759)**

Use this parameter to set the total number of autoreset trials.

If the number of trials during the trial time is more than the value of this parameter, a permanent fault shows. If not, the fault goes out of view after the trial time is completed. The fault type does not have an effect on the maximum number of trials.

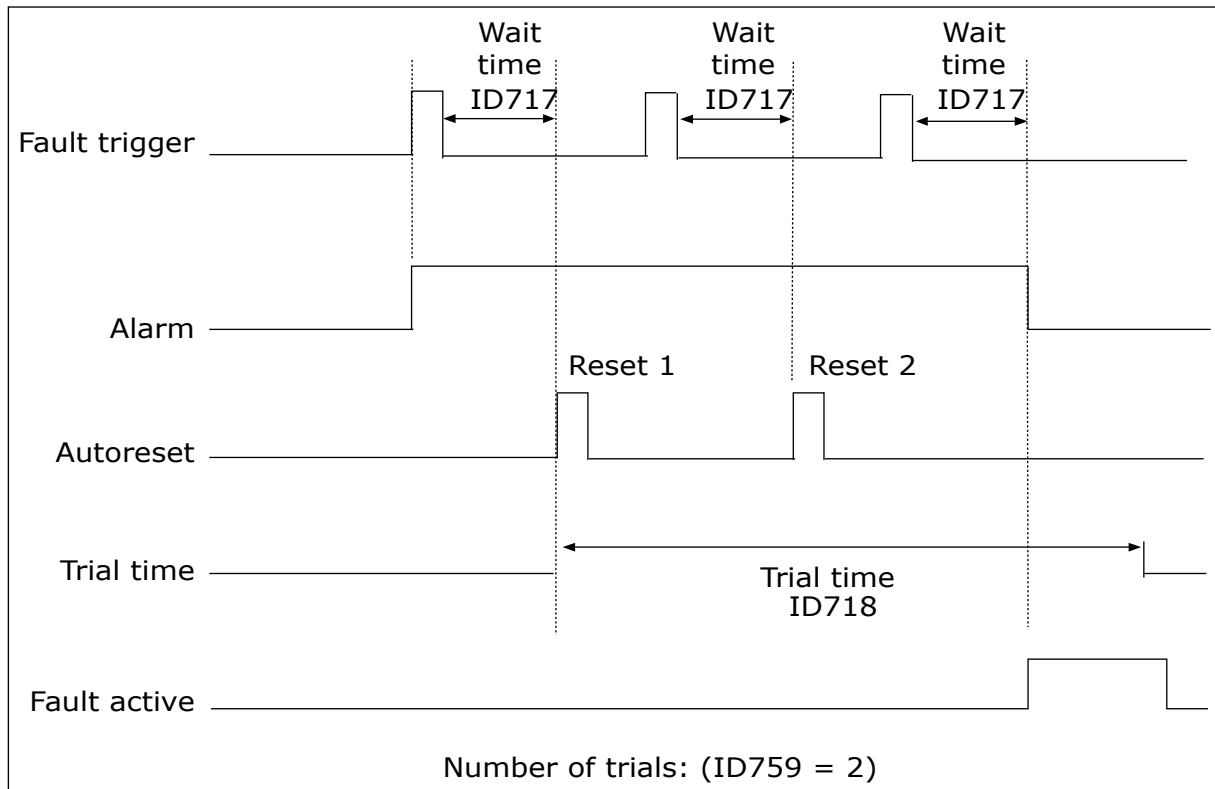

Fig. 63: The Automatic reset function

**P3.10.6 AUTORESET: UNDERVOLTAGE (ID 720)**

Use this parameter to enable the automatic reset after an undervoltage fault.

**P3.10.7 AUTORESET: OVERVOLTAGE (ID 721)**

Use this parameter to enable the automatic reset after an overvoltage fault.

**P3.10.8 AUTORESET: OVERCURRENT (ID 722)**

Use this parameter to enable the automatic reset after an overcurrent fault.

**P3.10.9 AUTORESET: AI LOW (ID 723)**

Use this parameter to enable the automatic reset after a fault caused by low AI signal.

**P3.10.10 AUTORESET: UNIT OVERTEMPERATURE (ID 724)**

Use this parameter to enable the automatic reset after a fault caused by unit overtemperature.

**P3.10.11 AUTORESET: MOTOR OVERTEMPERATURE (ID 725)**

Use this parameter to enable the automatic reset after a fault caused by motor overtemperature.

**P3.10.12 AUTORESET: EXTERNAL FAULT (ID 726)**

Use this parameter to enable the automatic reset after an external fault.

**P3.10.13 AUTORESET: UNDERLOAD FAULT (ID 738)**

Use this parameter to enable the automatic reset after an underload fault.

**P3.10.14 AUTORESET: PID SUPERVISION FAULT (ID 776)**

Use this parameter to enable the automatic reset after a PID supervision fault.

**P3.10.15 AUTORESET: EXT PID SUPERVISION FAULT (ID 777)**

Use this parameter to enable the automatic reset after an external PID supervision fault.

**10.12 APPLICATION SETTINGS****P3.11.1 PASSWORD (ID 1806)**

Use this parameter to set the administrator password.

**P3.11.2 C/F SELECTION (ID 1197)**

Use this parameter to set the temperature measuring unit.  
The system shows all the temperature-related parameters and monitoring values in the set unit.

**P3.11.3 KW/HP SELECTION (ID 1198)**

Use this parameter to set the power measuring unit.

The system shows all the power-related parameters and monitoring values in the set unit.

### **3.11.4 MULTIMONITOR VIEW (ID 1196)**

Use this parameter to set the division of the display of the control panel into sections in the multimonitor view.

### **3.11.5 FUNCT BUTTON CONFIGURATION (ID 1195)**

Use this parameter to set the values of the FUNCT button.  
The values that you set with this parameter will be available when you push the FUNCT button on the keypad.

## **10.13 TIMER FUNCTIONS**

The timer functions make it possible for the internal RTC (Real Time Clock) to control functions. All the functions that can be controlled with a digital input, can also be controlled with the RTC, with time channels 1-3. It is not necessary to have an external PLC to control a digital input. You can program the closed and opened intervals of the input internally.

To get the best results of the timer functions, install a battery, and make the settings of the Real Time Clock carefully in the Start-up wizard. The battery is available as an option.



#### **NOTE!**

We do not recommend that you use the timer functions without an auxiliary battery. The time and date settings of the drive are reset at each power down, if there is no battery for the RTC.

## **TIME CHANNELS**

You can assign the output of the interval and/or timer functions to time channels 1-3. You can use the time channels to control on/off type functions, for example relay outputs or digital inputs. To configure the on/off logic of the time channels, assign intervals and/or timers to them. A time channel can be controlled by many different intervals or timers.



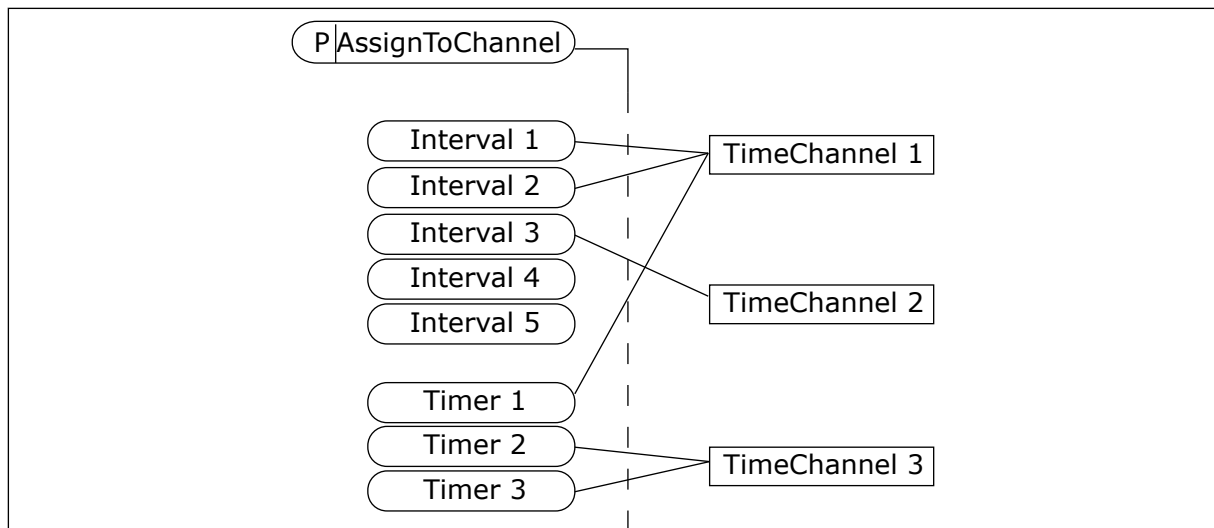

Fig. 64: Assigning intervals and timers to time channels is flexible. Every interval and timer has a parameter with which you can assign them to a time channel.

## INTERVALS

Use parameters to give each interval an ON Time and OFF Time. It is the daily active time of the interval during the days set with parameters From Day and To Day. For example, with the parameter settings below, the interval is active from 7 am to 9 am from Monday to Friday. The time channel is like a digital input, but virtual.

ON Time: 07:00:00  
 OFF Time: 09:00:00  
 From Day: Monday  
 To Day: Friday

## TIMERS

Use the timers to set a time channel as active for a period with a command from a digital input or a time channel.

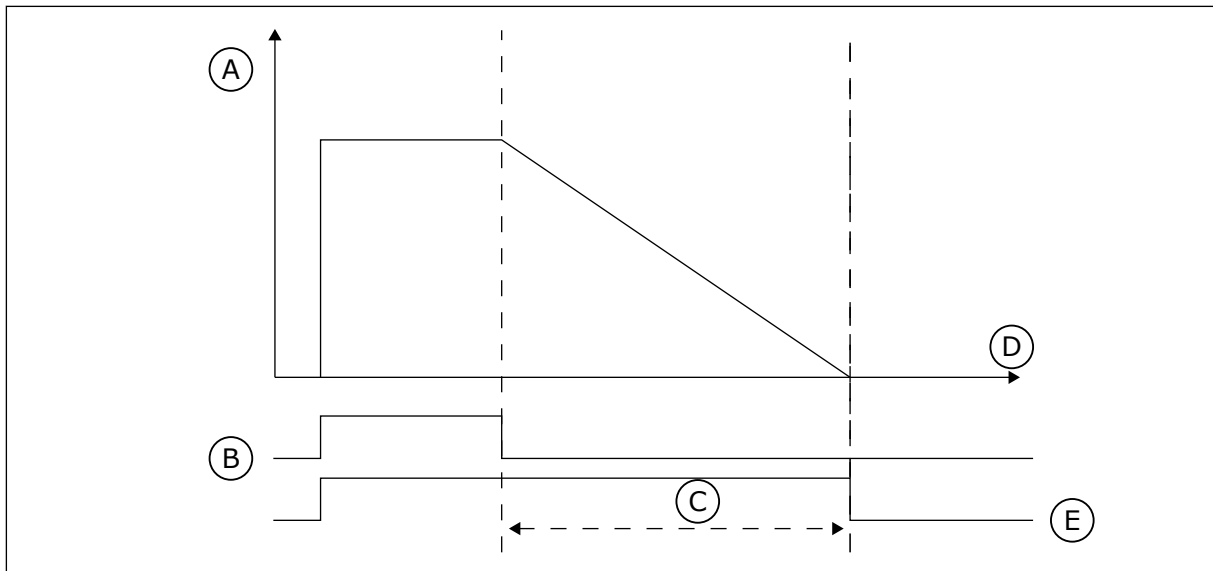

Fig. 65: The activation signal comes from a digital input or a virtual digital input, like a time channel. The timer counts down from the falling edge.

- |                   |         |
|-------------------|---------|
| A. Remaining time | D. Time |
| B. Activation     | E. OUT  |
| C. Duration       |         |

The parameters below will set the timer active when the digital input 1 on the slot A is closed. They will also keep the timer active for 30 s after it is opened.

- Duration: 30 s
- Timer: DigIn SlotA.1

You can use a duration of 0 seconds to override a time channel that is activated from a digital input. There is no off delay after the falling edge.

### Example:

### Problem:

The AC drive is in a warehouse and controls air conditioning. It must operate between 7 am and 5 pm on weekdays and between 9 am and 1 pm on weekends. It is also necessary for the drive to operate outside these hours, if there are personnel in the building. The drive must continue to operate 30 minutes after the personnel has left.

### Solution:

Set 2 intervals, 1 for weekdays and 1 for weekends. A timer is also necessary to activate the process outside the set hours. See the configuration below.

### Interval 1

P3.12.1.1: ON Time: 07:00:00

P3.12.1.2: OFF Time: 17:00:00

P3.12.1.3: Days: Monday, Tuesday, Wednesday, Thursday, Friday

P3.12.1.4: Assign to channel: Time channel 1

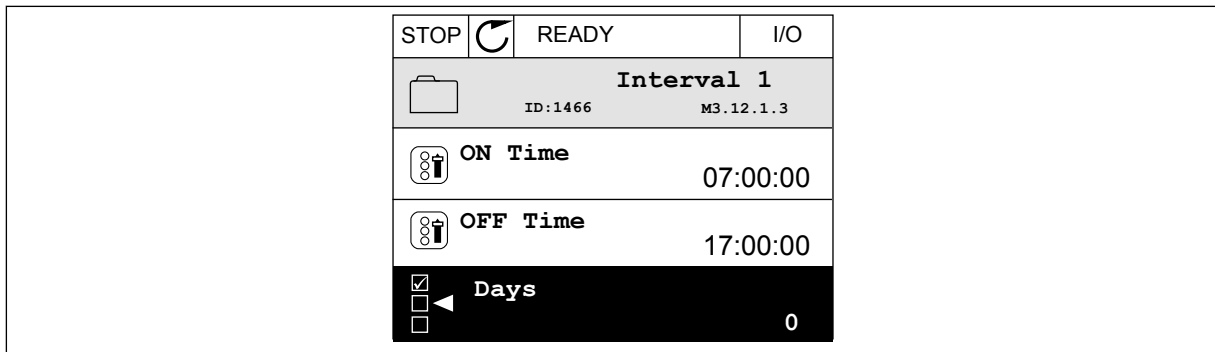

Fig. 66: Using timer functions to make an interval

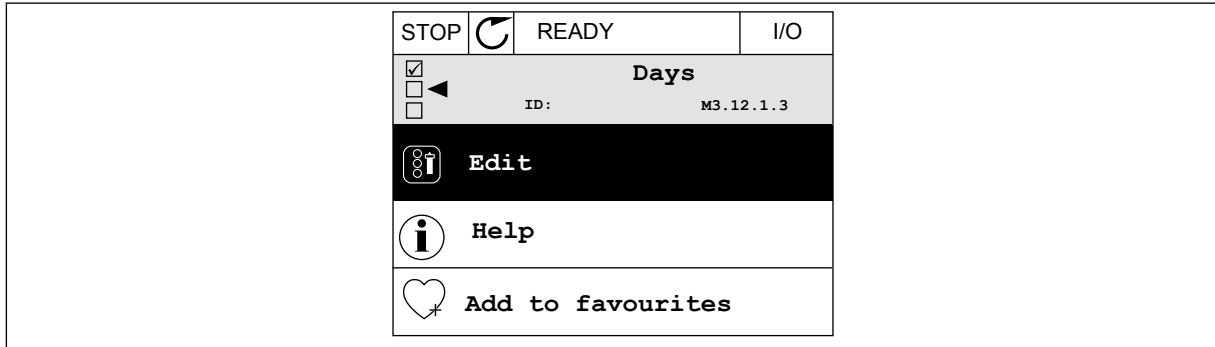

Fig. 67: Going into the Edit mode

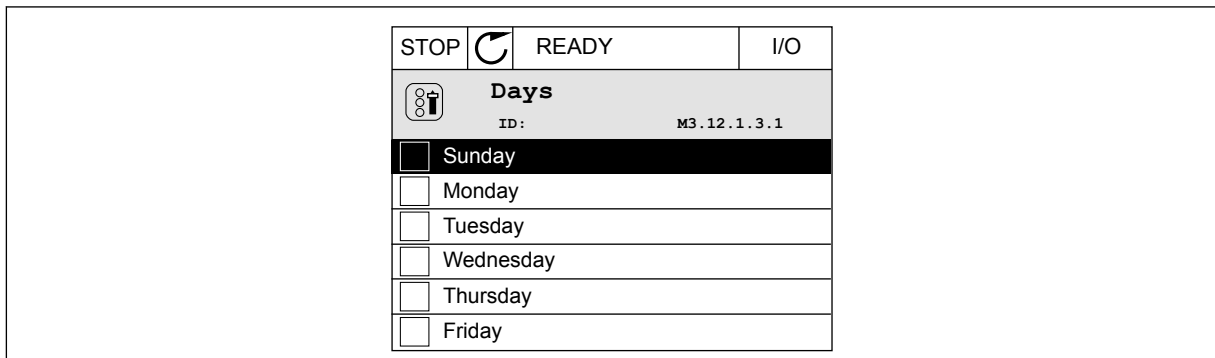

Fig. 68: The checkbox selection for the weekdays

**Interval 2**

- P3.12.2.1: ON Time: 09:00:00
- P3.12.2.2: OFF Time: 13:00:00
- P3.12.2.3: Days: Saturday, Sunday
- P3.12.2.4: Assign to channel: Time channel 1

**Timer 1**

- P3.12.6.1: Duration: 1800 s (30 min)
- P3.12.6.2: Timer 1: DigIn SlotA.1 (The parameter is located in the digital inputs menu.)
- P3.12.6.3: Assign to channel: Time channel 1
- P3.5.1.1: Control signal 1 A: Time Channel 1 for the I/O Run command

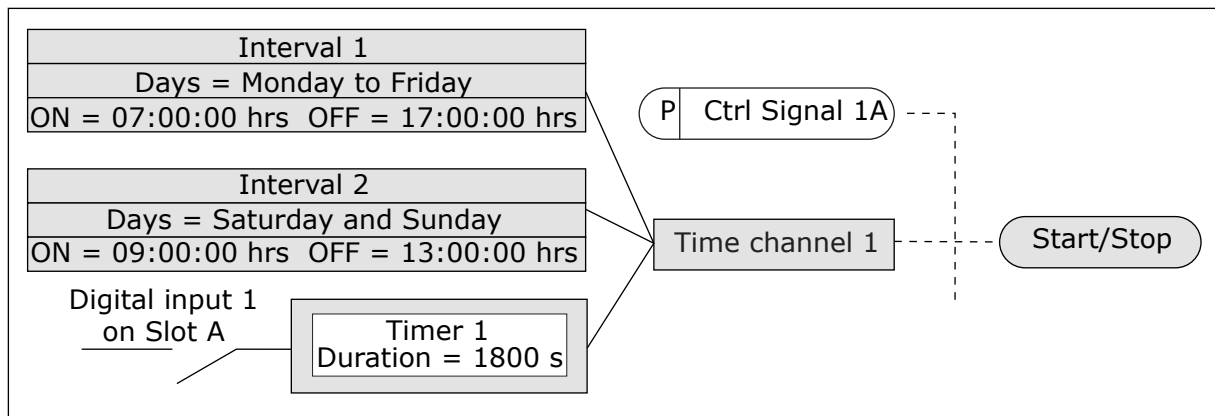

Fig. 69: Time channel 1 is used as the control signal for the start command instead of a digital input

#### **P3.12.1.1 ON TIME (ID 1464)**

Use this parameter to set the time of day when the output of the interval function is activated.

#### **P3.12.1.2 OFF TIME (ID 1465)**

Use this parameter to set the time of day when the output of the interval function is deactivated.

#### **P3.12.1.3 DAYS (ID 1466)**

Use this parameter to select the days of the week when the interval function is enabled.

#### **P3.12.1.4 ASSIGN TO CHANNEL (ID 1468)**

Use this parameter to select the time channel where the output of the interval function is assigned.

You can use the time channels to control the on/off type functions, for example relay outputs or any functions that can be controlled by a DI signal.

#### **P3.12.6.1 DURATION (ID 1489)**

Use this parameter to set the duration that the timer runs when the activation signal is removed (Off-delay).

#### **P3.12.6.2 TIMER 1 (ID 447)**

Use this parameter to select the digital input signal that starts the timer.

The output of the timer is activated when this signal is activated. The timer starts to count when this signal is deactivated (falling edge). The output is deactivated when the time that is set with the duration parameter has elapsed.

The rising edge starts Timer 1 that is programmed in Group 3.12.

#### **P3.12.6.3 ASSIGN TO CHANNEL (ID 1490)**

Use this parameter to select the time channel where the output of the timer function is assigned.

You can use the time channels to control the on/off type functions, \ffor example relay outputs or any functions that can be controlled by a DI signal.

## **10.14 PID CONTROLLER**

### **10.14.1 BASIC SETTINGS**

#### ***P3.13.1.1 PID GAIN (ID 118)***

Use this parameter to adjust the gain of the PID controller.  
If this parameter is set to 100%, a change of 10% in the error value causes the controller output to change by 10%.

#### ***P3.13.1.2 PID INTEGRATION TIME (ID 119)***

Use this parameter to adjust the integration time of the PID controller.  
If this parameter is set to 1.00 s, a change of 10% in the error value causes the controller output to change by 10.00%/s.

#### ***P3.13.1.3 PID DERIVATION TIME (ID 132)***

Use this parameter to adjust the derivation time of the PID controller.  
If this parameter is set to 1.00 s, a change of 10% in the error value during 1.00 s causes the controller output to change by 10.00%.

#### ***P3.13.1.4 PROCESS UNIT SELECTION (ID 1036)***

Use this parameter to select the unit for the feedback and the setpoint signals of the PID controller.  
Make a selection of the unit for the actual value.

#### ***P3.13.1.5 PROCESS UNIT MIN (ID 1033)***

Use this parameter to set the minimum value of the PID feedback signal.  
For example, an analogue signal of 4...20 mA corresponds to the pressure of 0...10 bar. The value in process units at a 0% feedback or setpoint. This scaling is done for monitoring purposes only. The PID controller still uses the percentage internally for feedbacks and setpoints.

#### ***P3.13.1.6 PROCESS UNIT MAX (ID 1034)***

Use this parameter to set the maximum value of the PID feedback signal.  
For example, an analogue signal of 4...20 mA corresponds to the pressure of 0...10 bar. The value in process units at a 0% feedback or setpoint. This scaling is done for monitoring purposes only. The PID controller still uses the percentage internally for feedbacks and setpoints.

#### ***P3.13.1.7 PROCESS UNIT DECIMALS (ID 1035)***

Use this parameter to set the number of decimals for the process unit values.  
For example, an analogue signal of 4...20 mA corresponds to the pressure of 0...10 bar.

The value in process units at a 0% feedback or setpoint. This scaling is done for monitoring purposes only. The PID controller still uses the percentage internally for feedbacks and setpoints.

### **P3.13.1.8 ERROR INVERSION (ID 340)**

Use this parameter to invert the error value of the PID controller.

### **P3.13.1.9 DEAD BAND (ID 1056)**

Use this parameter to set the dead band area around the PID setpoint value.

The value of this parameter is given in the selected process unit. The output of the PID controller is locked if the feedback value stays in the dead band area for the set time.

### **P3.13.1.10 DEAD BAND DELAY (ID 1057)**

Use this parameter to set the time that the feedback value must stay in the dead band area before the output of the PID controller is locked.

If the actual value stays in the dead band area for a time set in Dead Band Delay, the PID controller output is locked. This function prevents wear and unwanted movements of the actuators, for example valves.

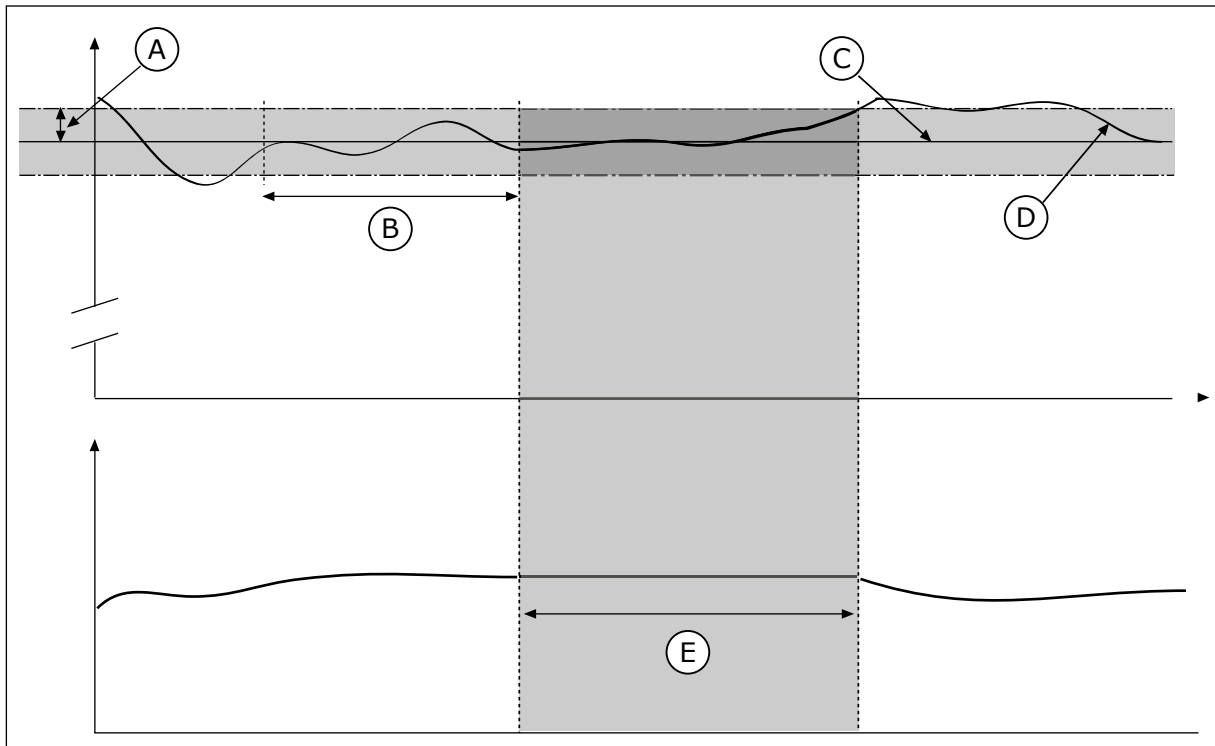

Fig. 70: The Dead band function

- |                             |                  |
|-----------------------------|------------------|
| A. Dead band (ID1056)       | D. Actual value  |
| B. Dead band delay (ID1057) | E. Output locked |
| C. Reference                |                  |

## 10.14.2 SETPOINTS

### **P3.13.2.1 KEYPAD SETPOINT 1 (ID 167)**

Use this parameter to set the setpoint value of the PID controller when the setpoint source is 'Keypad SP'.

The value of this parameter is given in the selected process unit.

### **P3.13.2.2 KEYPAD SETPOINT 2 (ID 168)**

Use this parameter to set the setpoint value of the PID controller when the setpoint source is 'Keypad SP'.

The value of this parameter is given in the selected process unit.

### **P3.13.2.3 SETPOINT RAMP TIME (ID 1068)**

Use this parameter to set the rising and falling ramp times for the setpoint changes.

Ramp time is the time that is necessary for the setpoint value to change from minimum to maximum. If the value of this parameter is set to 0, no ramps are used.

### **P3.13.2.4 PID SETPOINT BOOST ACTIVATION (ID 1046)**

Use this parameter to select the digital input signal that activates the boost for the PID setpoint value.

### **P3.13.2.5 PID SELECT SETPOINT (ID 1047)**

Use this parameter to set the digital input signal that selects the PID setpoint value to be used.

### **P3.13.2.6 SETPOINT SOURCE 1 SELECTION (ID 332)**

Use this parameter to select the source of the PID setpoint signal.

The AIs and the ProcessDataIn are handled as percentages (0.00-100.00%) and scaled according to the setpoint minimum and maximum.



#### **NOTE!**

The ProcessDataIn signals use 2 decimals.

If temperature inputs are selected, you must set the values of parameters P3.13.1.5 Process Unit Min and P3.13.1.6 Process Unit Max to correspond to the the scale of the temperature measurement board: ProcessUnitMin = -50 °C and ProcessUnitMax = 200 °C.

### **P3.13.2.7 SETPOINT 1 MINIMUM (ID 1069)**

Use this parameter to set the minimum value of the setpoint signal.

### **P3.13.2.8 SETPOINT 1 MAXIMUM (ID 1070)**

Use this parameter to set the maximum value of the setpoint signal.

**P3.13.2.9 SETPOINT 1 BOOST (ID 1071)**

Use this parameter to set the multiplier for the setpoint boost function. When the setpoint boost command is given, the setpoint value is multiplied with the factor that is set with this parameter.

**10.14.3 FEEDBACK****P3.13.3.1 FEEDBACK FUNCTION (ID 333)**

Use this parameter to select if the feedback value is taken from a single signal or combined from two signals.

You can select the mathematical function that is used when the two feedback signals are combined.

**P3.13.3.2 FEEDBACK FUNCTION GAIN (ID 1058)**

Use this parameter to adjust the gain of the feedback signal. This parameter is used, for example, with the value 2 in Feedback Function.

**P3.13.3.3 FEEDBACK 1 SOURCE SELECTION (ID 334)**

Use this parameter to select the source of the PID feedback signal. The Als and the ProcessDataIn are handled as percentages (0.00-100.00%) and scaled according to the feedback minimum and maximum.

**NOTE!**

The ProcessDataIn signals use 2 decimals.

If temperature inputs are selected, you must set the values of parameters P3.13.1.5 Process Unit Min and P3.13.1.6 Process Unit Max to correspond to the the scale of the temperature measurement board: ProcessUnitMin = -50 °C and ProcessUnitMax = 200 °C.

**P3.13.3.4 FEEDBACK 1 MINIMUM (ID 336)**

Use this parameter to set the minimum value of the feedback signal.

**P3.13.3.5 FEEDBACK 1 MAXIMUM (ID 337)**

Use this parameter to set the maximum value of the feedback signal.

**10.14.4 FEEDFORWARD****P3.13.4.1 FEEDFORWARD FUNCTION (ID 1059)**

Use this parameter to select if the feedforward value is taken from a single signal or combined from two signals.

You can select the mathematical function that is used when the two feedforward signals are combined.

Accurate process models are usually necessary for the Feedforward function. In some conditions, a gain and offset type of feedforward is sufficient. The feedforward part does not



use the feedback measurements of the actual controlled process value. The feedforward control uses other measurements that have an effect on the controlled process value.

#### EXAMPLE 1:

You can control the water level of a tank with flow control. The target water level is set as a setpoint, and the actual level as feedback. The control signal monitors the flow that comes in.

The outflow is like a disturbance that you can measure. With the measurements of the disturbance, you can try to adjust this disturbance with a feedforward control (gain and offset) that you add to the PID output. The PID controller reacts much faster to changes in the outflow than if you only measure the level.

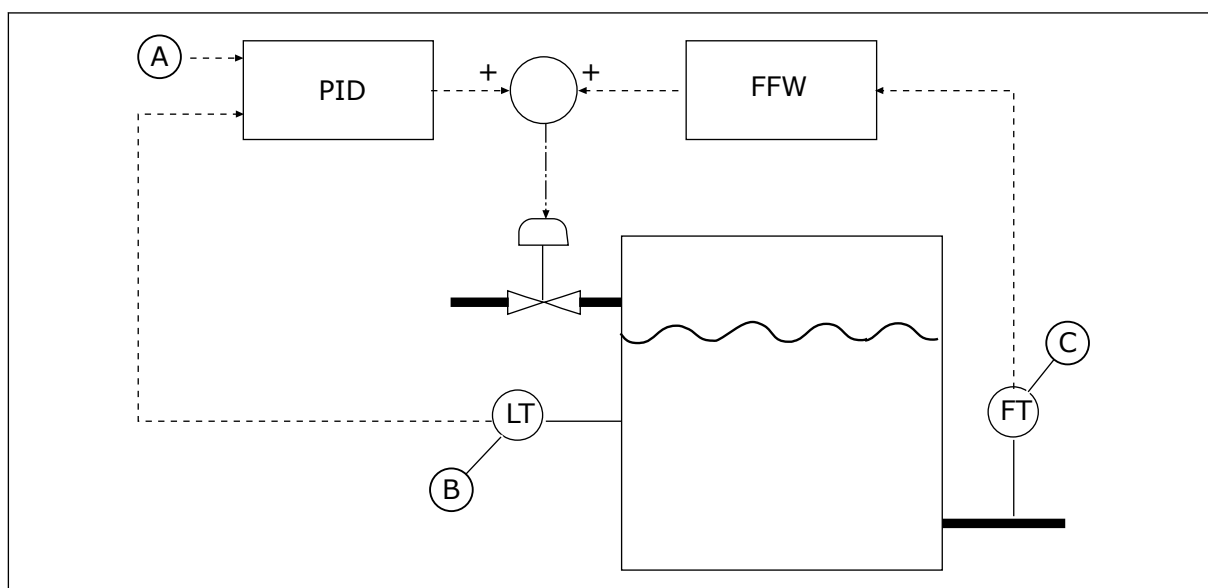

Fig. 71: The feedforward control

- A. Level ref
- B. Level control

- C. Outflow control

#### **P3.13.4.2 GAIN**

Use this parameter to adjust the gain of the feedforward signal.

#### **P3.13.4.3 FEEDFORWARD 1 SOURCE SELECTION**

Use this parameter to select the source of the PID feedforward signal.

#### **P3.13.4.4 FEEDFORWARD 1 MINIMUM**

Use this parameter to set the minimum value of the feedforward signal.

#### **P3.13.4.5 FEEDFORWARD 1 MAXIMUM**

Use this parameter to set the maximum value of the feedforward signal.

## 10.14.5 SLEEP FUNCTION

### ***P3.13.5.1 SP1 SLEEP FREQUENCY (ID 1016)***

Use this parameter to set the limit below which the output frequency of the drive must stay for a set time before the drive goes to the sleep state.

The value of this parameter is used when the signal of the PID controller setpoint is taken from the setpoint source 1.

#### **Criteria for going to sleep mode**

- Output frequency remains below sleep frequency for longer than defined sleep delay time
- PID feedback signal remains above defined wake up level

#### **Criteria for waking from sleep**

- PID feedback signal falls below defined wake up level



#### **NOTE!**

A wrong set wake up level might not allow the drive to go into sleep mode

### ***P3.13.5.2 SP1 SLEEP DELAY (ID 1017)***

Use this parameter to set the minimum duration that the output frequency of the drive must stay below the set limit before the drive goes to the sleep state.

The value of this parameter is used when the signal of the PID controller setpoint is taken from the setpoint source 1.

### ***P3.13.5.3 SP1 WAKE-UP LEVEL (ID 1018)***

Use this parameter to set the level at which the drive wakes up from the sleep state. When the PID feedback value goes below the level that is set with this parameter, drive wakes up from the sleep state. The operation of this parameter is selected with wake up mode parameter.

### ***P3.13.5.4 SP1 WAKE-UP MODE (ID 1019)***

Use this parameter to select the operation for the wake up level parameter.

The drive wakes up from the sleep mode when the value of PID Feedback goes below the Wake-up level.

This parameter defines if Wake-up level is used as a static absolute level or as a relative level which follows PID setpoint value.

Selection 0 = Absolute level (The wake-up level is a static level that does not follow the setpoint value.)

Selection 1 = Relative setpoint (The wake-up level is an offset below the actual setpoint value. The wake-up level follows the actual setpoint.)

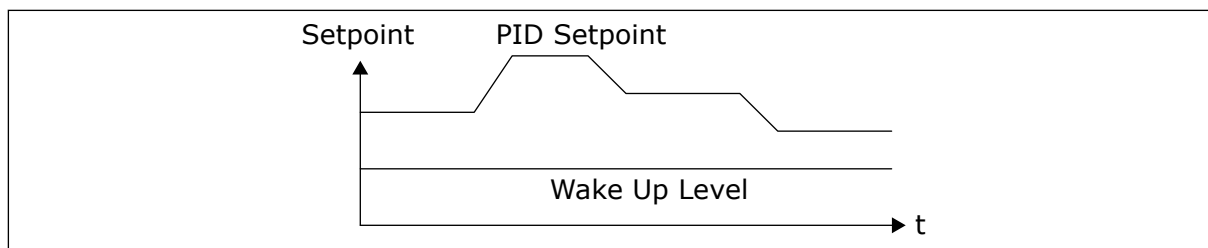

Fig. 72: Wake-up Mode: absolute level

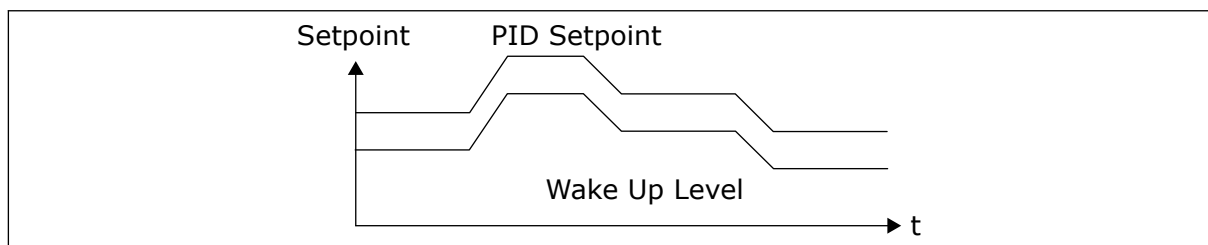

Fig. 73: Wake-up Mode: relative setpoint

#### **P3.13.5.5 SP2 SLEEP FREQUENCY (ID 1075)**

See the description of parameter P3.13.5.1.

#### **P3.13.5.6 SP2 SLEEP DELAY (1076)**

See the description of parameter P3.13.5.2.

#### **P3.13.5.7 SP2 WAKE-UP LEVEL (ID 1077)**

See the description of parameter P3.13.5.3.

#### **P3.13.5.8 SP2 WAKE-UP MODE (ID 1020)**

See the description of parameter P3.13.5.4

### **10.14.6 FEEDBACK SUPERVISION**

Use the feedback supervision to make sure that the PID Feedback value (the process value or the actual value) stays in the set limits. With this function you can, for example, find a pipe break and stop the flooding.

These parameters set the range in which the PID Feedback signal stays in correct conditions. If the PID Feedback signal does not stay in the range, and this continues longer than the delay, a Feedback supervision fault (the fault code 101) shows.

#### **P3.13.6.1 ENABLE FEEDBACK SUPERVISION (ID 735)**

Use this parameter to enable the feedback supervision function.

Use the feedback supervision to make sure that the PID feedback value stays in the set limits.

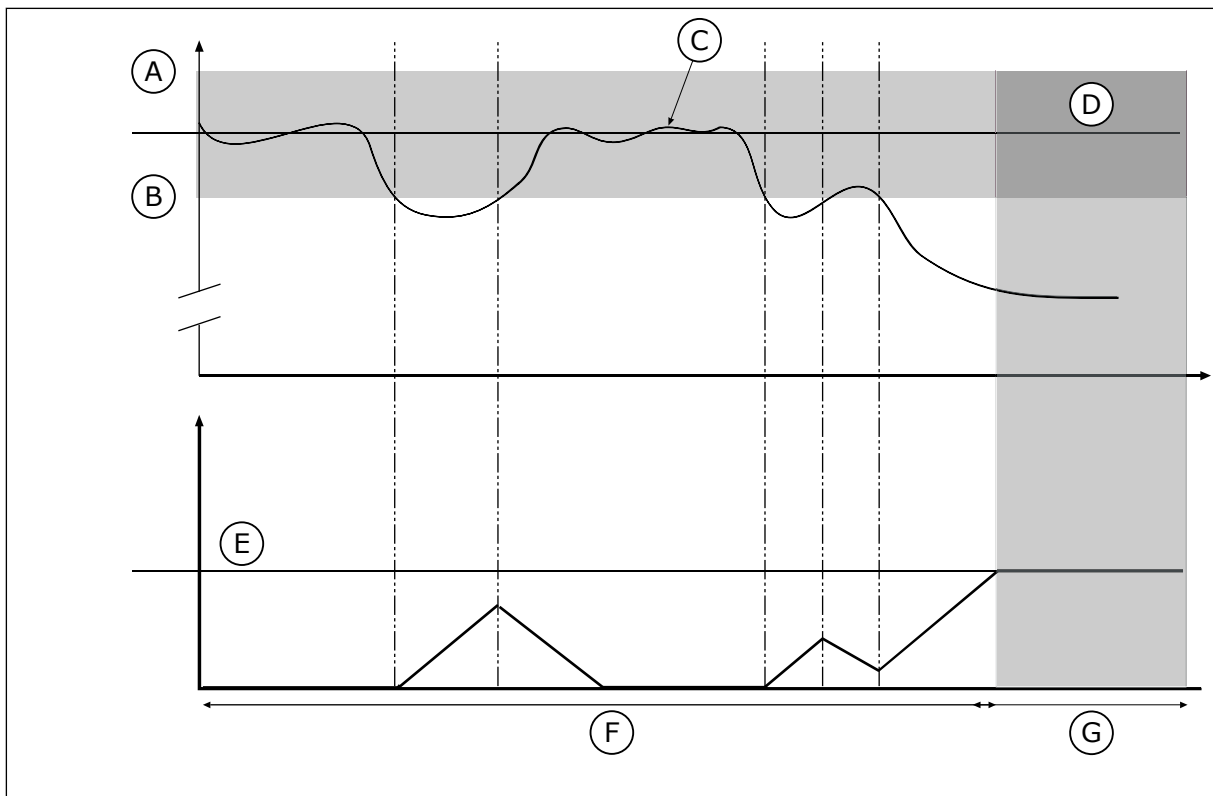

Fig. 74: The Feedback supervision function

- |                        |                    |
|------------------------|--------------------|
| A. Upper limit (ID736) | E. Delay (ID737)   |
| B. Lower limit (ID758) | F. Regulating mode |
| C. Actual value        | G. Alarm or fault  |
| D. Reference           |                    |

### **P3.13.6.2 UPPER LIMIT (ID 736)**

Use this parameter to set the high limit for the PID feedback signal. If the value of the PID feedback signal goes above this limit for longer than the set time, a feedback supervision fault occurs.

### **P3.13.6.3 LOWER LIMIT (ID 758)**

Use this parameter to set the low limit for the PID feedback signal. If the value of the PID feedback signal goes below this limit for longer than the set time, a feedback supervision fault occurs. Set the upper limit and the lower limit around the reference. When the actual value is less or more than the limits, a counter starts to count up. When the actual value is between the limits, the counter counts down. When the counter gets a value that is higher than the value of P3.13.6.4 Delay, an alarm or a fault shows. You can make a selection of the response with parameter P3.13.6.5 [Response to PID1 Supervision Fault].

### **P3.13.6.4 DELAY (ID 737)**

Use this parameter to set the maximum time for the PID feedback signal to stay outside the supervision limits before the feedback supervision fault occurs. If the target value is not reached in this time, a fault or alarm shows.

### P3.13.6.5 RESPONSE TO PID SUPERVISION FAULT (ID 749)

Use this parameter to select the response of the drive to a 'PID Supervision' fault. If the PID feedback value is not in the supervision limits for longer than the supervision delay, a PID supervision fault occurs.

### 10.14.7 PRESSURE LOSS COMPENSATION

When you pressurise a long pipe that has many outlets, the best position for the sensor is in the middle of the pipe (the position 2 in the figure). You can also put the sensor directly after the pump. This gives the right pressure directly after the pump, but farther in the pipe, the pressure drops with the flow.

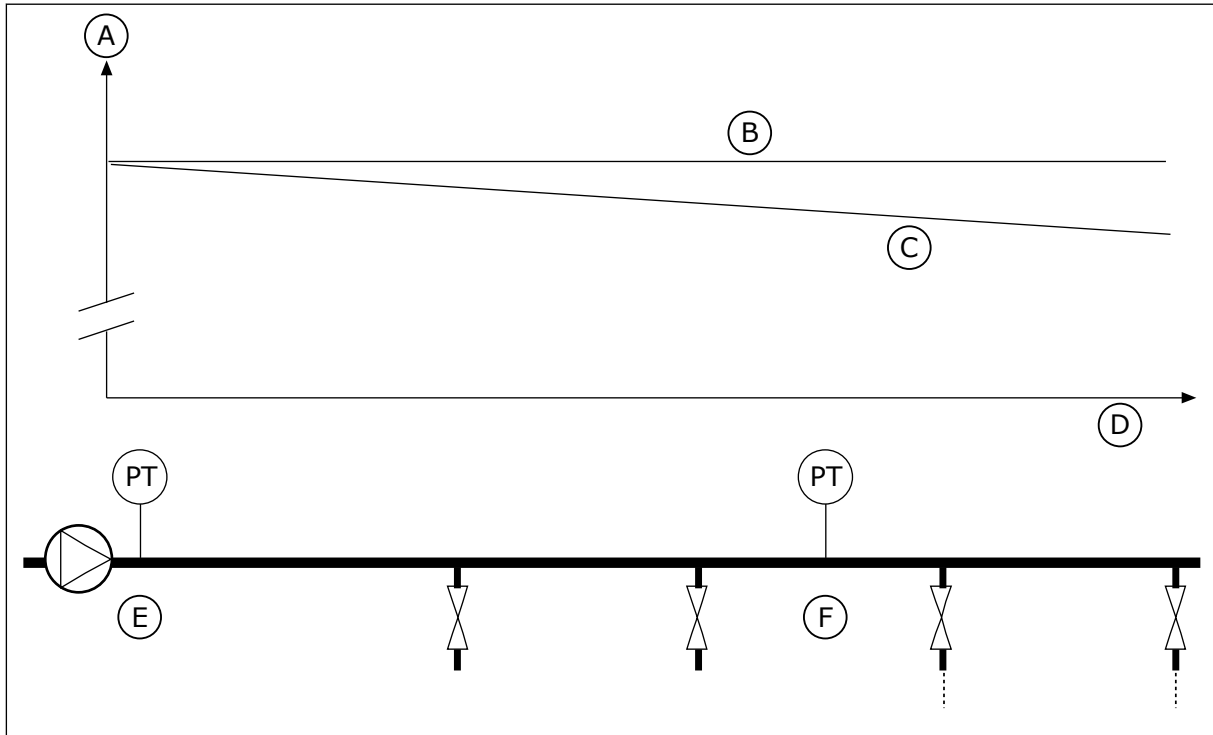

Fig. 75: The position of the pressure sensor

- |              |                |
|--------------|----------------|
| A. Pressure  | D. Pipe length |
| B. No flow   | E. Position 1  |
| C. With flow | F. Position 2  |

### P3.13.7.1 ENABLE COMPENSATION FOR SETPOINT 1 (ID 1189)

Use this parameter to enable the pressure loss compensation in the pump system. In a pressure controlled system, this function compensates the pressure loss that occurs at the end of the pipe line due to the liquid flow.

### P3.13.7.2 SETPOINT 1 MAX COMPENSATION (ID 1190)

Use this parameter to set the maximum compensation for PID setpoint value that is applied when the output frequency of the drive is at the maximum frequency.

The compensation value is added to the actual setpoint value as a function of the output frequency.

Setpoint compensation = max compensation \* (FreqOut-MinFreq)/(MaxFreq-MinFreq).

The sensor is put in position 1. The pressure in the pipe stays constant when there is no flow. But with flow, the pressure decreases farther in the pipe. To compensate for this, lift the setpoint as the flow increases. Then the output frequency makes an estimate of the flow, and the setpoint increases linearly with the flow.

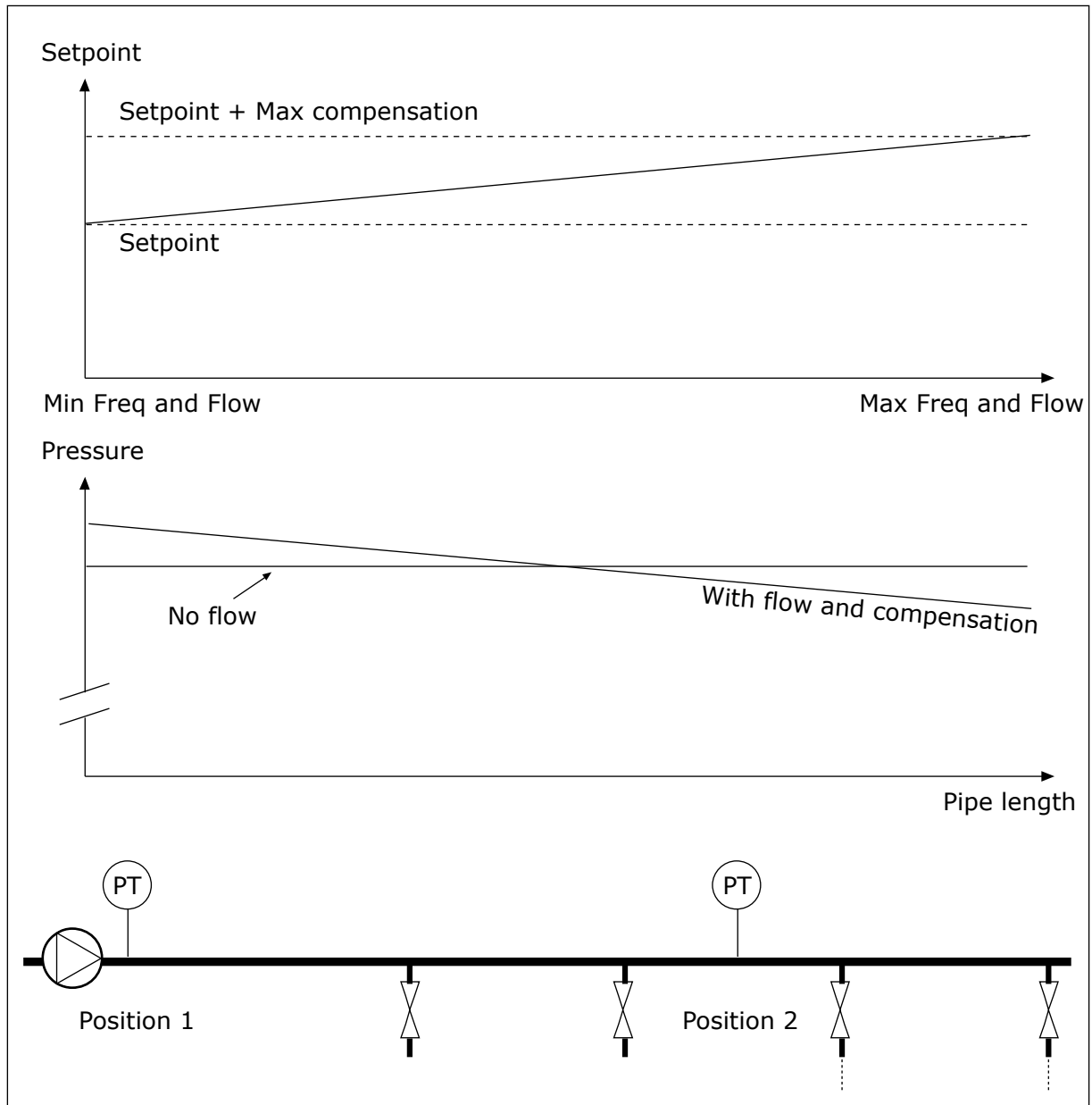

Fig. 76: Enable setpoint 1 for pressure loss compensation

### 10.14.8 SOFT FILL

The Soft fill function is used to move the process to a set level at a slow speed before the PID controller starts to control. If the process does not go to the set level during the timeout, a fault shows.

You can use the function to fill an empty pipe slowly and prevent strong currents of water that could break the pipe.

We recommend that you always use the Soft fill function when you use the Multi-pump function.

#### ***P3.13.8.1 ENABLE SOFT FILL (ID 1094)***

Use this parameter to enable the Soft Fill function.

You can use the function to fill an empty pipe slowly and prevent strong currents of fluid that could break the pipe.

#### ***P3.13.8.2 SOFT FILL FREQUENCY (ID 1055)***

Use this parameter to set the frequency reference of the drive when the Soft Fill function is used.

The drive accelerates to this frequency before it starts to control. After this, the drive goes to normal PID control mode.

#### ***P3.13.8.3 SOFT FILL LEVEL (ID 1095)***

Use this parameter to set the level below which the soft fill control is enabled when starting the drive.

The drive operates at the PID start frequency until the feedback reaches the set value. Then the PID controller starts to control the drive.

This parameter is applied if the soft fill function is set to 'Enabled, Level'.

#### ***P3.13.8.4. SOFT FILL TIMEOUT (ID 1096)***

Use this parameter to set the timeout time for the Soft Fill function.

When the soft fill function is set to 'Enabled, Level', this parameter gives the timeout for the soft fill level, after which the soft fill fault occurs. When the soft fill function is set to 'Enabled, Timeout', the drive operates at the soft fill frequency until the time set by this parameter expires.

The drive operates at the soft fill frequency until the feedback value is equal with the soft fill level. If the feedback value does not become equal with the soft fill level during the timeout, an alarm or fault shows. You can make a selection of the response with parameter P3.13.8.5 (PID Soft Fill Timeout Response).



#### **NOTE!**

If you set the value to be 0, no fault shows.

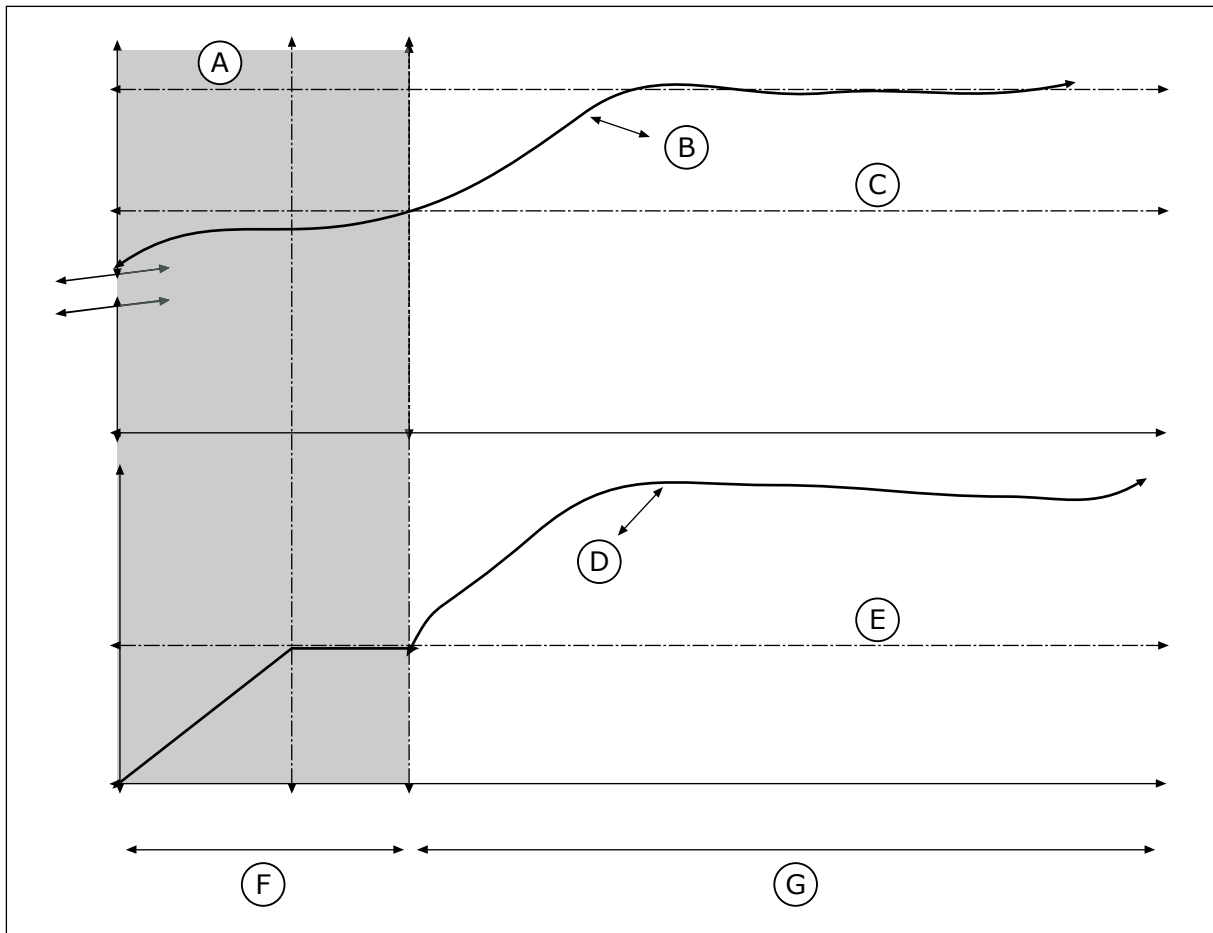

Fig. 77: The Soft fill function

- |                    |                        |
|--------------------|------------------------|
| A. Reference       | E. Soft fill frequency |
| B. Actual value    | F. Soft fill mode      |
| C. Soft fill level | G. Regulating mode     |
| D. Frequency       |                        |

### P3.13.8.5. PID SOFT FILL TIMEOUT RESPONSE (ID 748)

Use this parameter to select the response of the drive to a 'PID Soft Fill' fault. If the PIDFeedback value does not reach the set level in the time limit, a soft fill fault occurs.

### 10.14.9 INPUT PRESSURE SUPERVISION

Use the Input pressure supervision to make sure that there is enough water in the inlet of the pump. When there is enough water, the pump does not suck air and there is no suction cavitation. To use the function, install a pressure sensor on the pump inlet.

If the input pressure of the pump goes below the set alarm limit, an alarm shows. The setpoint value of the PID controller decreases and causes the output pressure of the pump to decrease. If the pressure goes below the fault limit, the pump is stops and a fault shows.



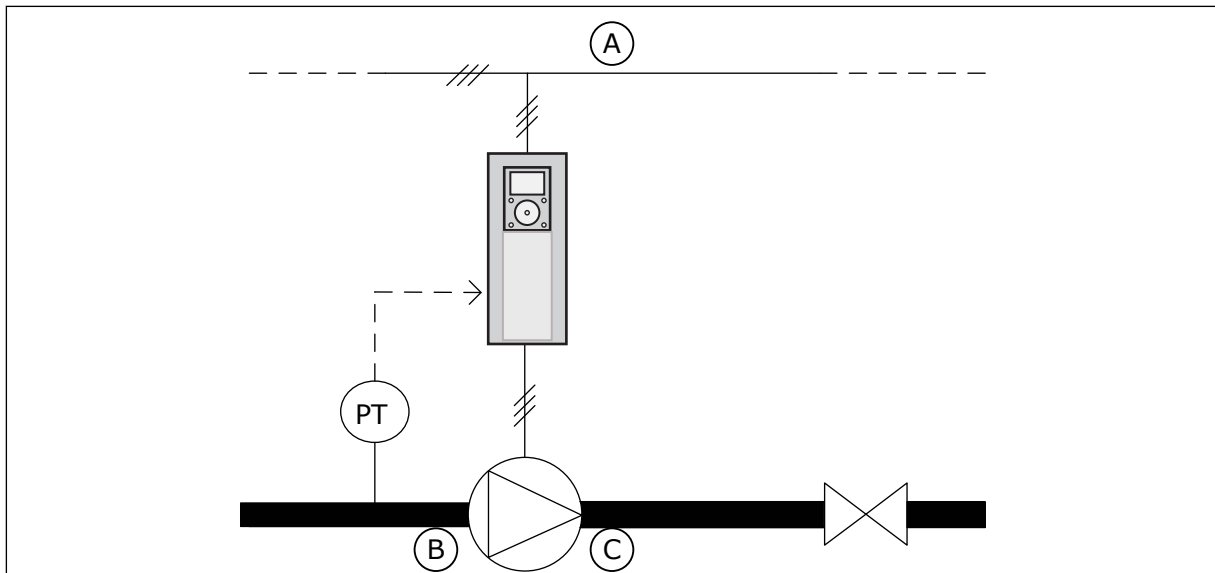

Fig. 78: The location of the pressure sensor

- A. Mains
- B. Inlet
- C. Outlet

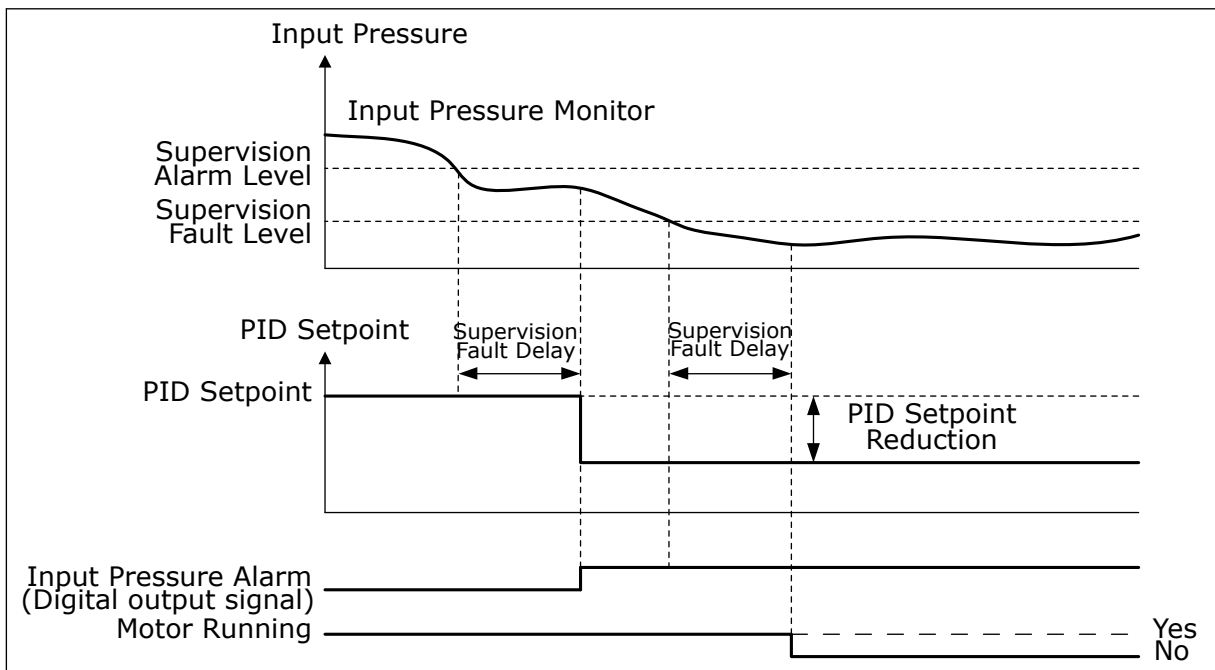

Fig. 79: The Input pressure supervision function

**P3.13.9.1 ENABLE SUPERVISION (ID 1685)**

Use this parameter to enable the Input Pressure Supervision function. Use this function to make sure that there is enough fluid in the inlet of the pump.

**P3.13.9.2 SUPERVISION SIGNAL (ID 1686)**

Use this parameter to select the source of the input pressure signal.

**P3.13.9.3 SUPERVISION UNIT SELECTION (ID 1687)**

Use this parameter to select the unit for the input pressure signal. You can scale the supervision signal (P3.13.9.2) to process units on the panel.

**P3.13.9.4 SUPERVISION UNIT DECIMALS (ID 1688)**

Use this parameter to set the number of decimals for the input pressure signal unit. You can scale the supervision signal (P3.13.9.2) to process units on the panel.

**P3.13.9.5 SUPERVISION UNIT MINIMUM VALUE (ID 1689)**

Use this parameter to set the minimum value of the input pressure signal. Enter the value in the selected process unit. For example, an analogue signal of 4...20 mA corresponds to the pressure of 0...10 bar.

**P3.13.9.6 SUPERVISION UNIT MAXIMUM VALUE (ID 1690)**

Use this parameter to set the maximum value of the input pressure signal. Enter the value in the selected process unit. For example, an analogue signal of 4...20 mA corresponds to the pressure of 0...10 bar.

**P3.13.9.7 SUPERVISION ALARM LEVEL (ID 1691)**

Use this parameter to set the limit for the input pressure alarm. If the measured input pressure goes below this limit, an input pressure alarm occurs.

**P3.13.9.8 SUPERVISION FAULT LEVEL (ID 1692)**

Use this parameter to set the limit for the input pressure fault. If the measured input pressure stays below this level for longer than the set time, an input pressure fault occurs.

**P3.13.9.9 SUPERVISION FAULT DELAY (ID 1693)**

Use this parameter to set the maximum duration for the input pressure to stay below the fault limit before an input pressure fault occurs.

**P3.13.9.10 PID SETPOINT REDUCTION (ID 1694)**

Use this parameter to set the rate of the reduction of the PID setpoint value when the measured input pressure is below the alarm limit.

**10.14.10 FROST PROTECTION**

Use the Frost protection function to protect the pump from frost damages. If the pump is in sleep mode and the temperature that is measured in the pump goes below the set protection temperature, operate the pump at a constant frequency (that is set in P3.13.10.6 Frost Protection Frequency). To use the function, you must install a temperature transducer or a temperature sensor on the pump covering or on the pipe line near the pump.

**P3.13.10.1 FROST PROTECTION (ID 1704)**

Use this parameter to enable the Frost Protection function.

If the measured temperature of the pump goes below the set level and the drive is in sleep state, the frost protection starts the pump to operate at a constant frequency.

#### ***P3.13.10.2 TEMPERATURE SIGNAL (ID 1705)***

Use this parameter to select the source of the temperature signal that is used for the Frost Protection function.

#### ***P3.13.10.3 TEMPERATURE SIGNAL MINIMUM (ID 1706)***

Use this parameter to set the minimum value of the temperature signal.  
For example, a temperature signal range of 4..20mA corresponds to the temperature of -50...200 celsius degrees.

#### ***P3.13.10.4 TEMPERATURE SIGNAL MAXIMUM (ID 1707)***

Use this parameter to set the maximum value of the temperature signal.  
For example, a temperature signal range of 4..20mA corresponds to the temperature of -50...200 celsius degrees.

#### ***P3.13.10.5 FROST PROTECTION TEMPERATURE (ID 1708)***

Use this parameter to set the temperature limit at which the drive starts.  
If the temperature of the pump goes below this limit and the drive is in the sleep state, the frost protection function starts the drive.

#### ***P3.13.10.6 FROST PROTECTION FREQUENCY (ID 1710)***

Use this parameter to set the frequency reference of the drive that is used when the frost protection function is activated.

### **10.15 EXTERNAL PID CONTROLLER**

#### ***P3.14.1.1 ENABLE EXTERNAL PID (ID 1630)***

Use this parameter to enable the PID controller.



#### **NOTE!**

This controller is for external use only. It can be used with an analogue output.

#### ***P3.14.1.2 START SIGNAL (ID 1049)***

Use this parameter to set the signal for starting and stopping the PID controller 2 for external usage.



#### **NOTE!**

If the PID2 controller is not enabled in the Basic menu for PID2, this parameter has no effect.

**P3.14.1.3 OUTPUT IN STOP (ID 1100)**

Use this parameter to set the output value of the PID controller as a percentage of its maximum output value when it is stopped from a digital output.  
 If the value of this parameter is set to 100%, a 10% change in the error value causes a 10% change in the controller output.

**10.16 MULTI-PUMP FUNCTION**

The Multi-pump function lets you control a maximum of 6 motors, pumps or fans with the PID controller.

The AC drive is connected to a motor, which is the regulating motor. The regulating motor connects and disconnects the other motors to/from the mains with relays. This is done to keep the right setpoint. The Autochange function controls the sequence in which the motors start to make sure that they wear equally. You can include the regulating motor in the autochange and interlock logic, or set it to always be Motor 1. It is possible to remove motors momentarily with the Interlock function, for example for maintenance.

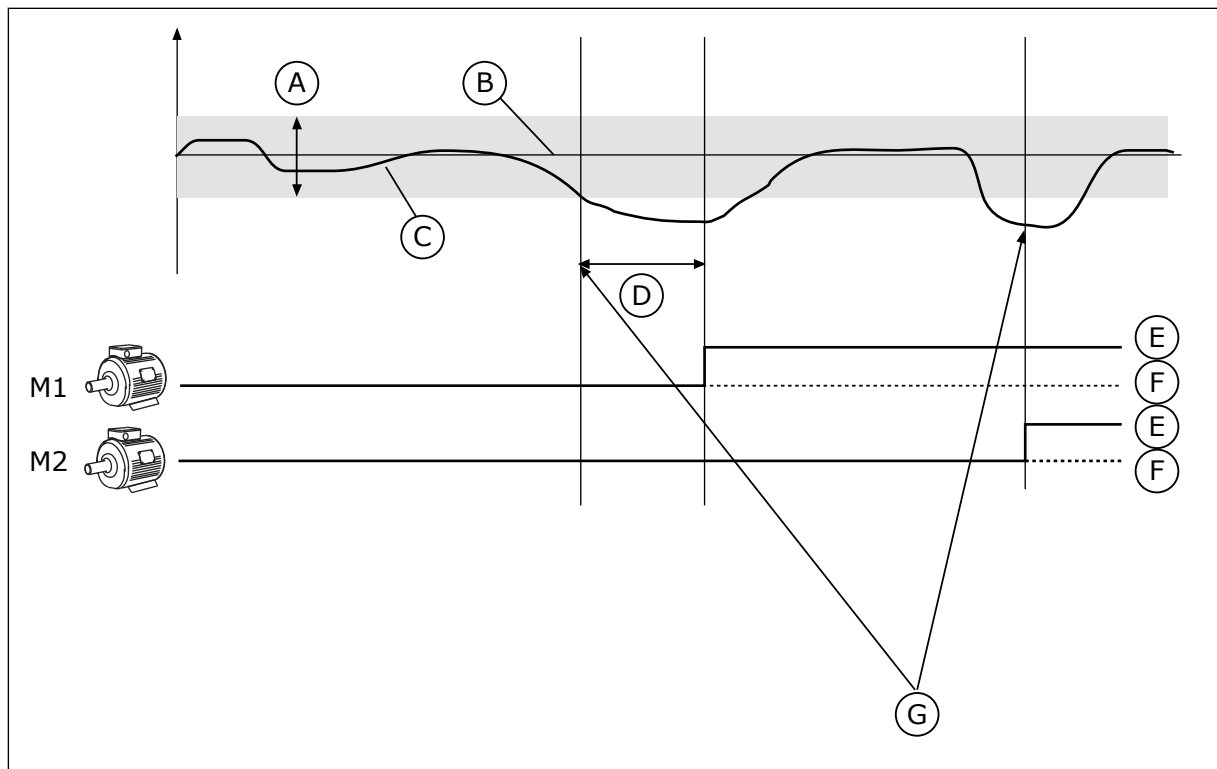

Fig. 80: The Multi-pump function

- |              |                                                              |
|--------------|--------------------------------------------------------------|
| A. Bandwidth | E. ON                                                        |
| B. Setpoint  | F. OFF                                                       |
| C. Feedback  | G. Drive is running at maximum or close to maximum frequency |
| D. Delay     |                                                              |

If the PID controller cannot keep the feedback in the set bandwidth, a motor or motors are connected or disconnected.

**When to connect and/or add motors:**

- The feedback value is not in the bandwidth area.
- The regulating motor operates at a close to maximum frequency (-2 Hz).
- The conditions above are true for longer than the bandwidth delay.
- There are more motors available

**When to disconnect and/or remove motors:**

- The feedback value is not in the bandwidth area.
- The regulating motor operates at a close to minimum frequency (+2 Hz).
- The conditions above are true for longer than the bandwidth delay.
- There are more motors that operate than the regulating one.

**P3.15.1 NUMBER OF MOTORS (ID 1001)**

Use this parameter to set the total number of motors/pumps used with the Multi-Pump system.

**P3.15.2 INTERLOCK FUNCTION (ID 1032)**

Use this parameter to enable or disable the interlocks.

The interlocks tell the Multi-pump system that a motor is not available. This can occur when the motor is removed from the system for maintenance or bypassed for manual control.

To use the interlocks, enable the parameter P3.15.2. Make a selection of the status for each motor with a digital input (the parameters from P3.5.1.34 to P3.5.1.39). If the value of the input is CLOSED, that is, active, the motor is available for the Multi-pump system. If not, the Multi-pump logic will not connect it.

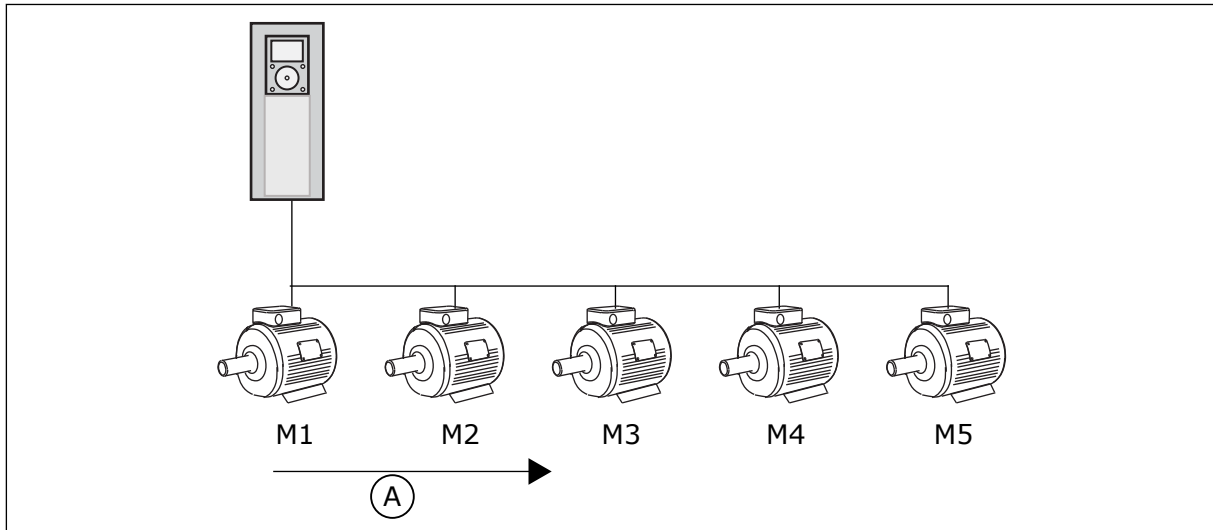

Fig. 81: The interlock logic 1

A. Starting order of motors

The sequence of the motors is **1, 2, 3, 4, 5**.

If you remove the interlock of Motor 3, that is, you set the value of P3.5.1.36 is set to OPEN, the sequence changes to **1, 2, 4, 5**.

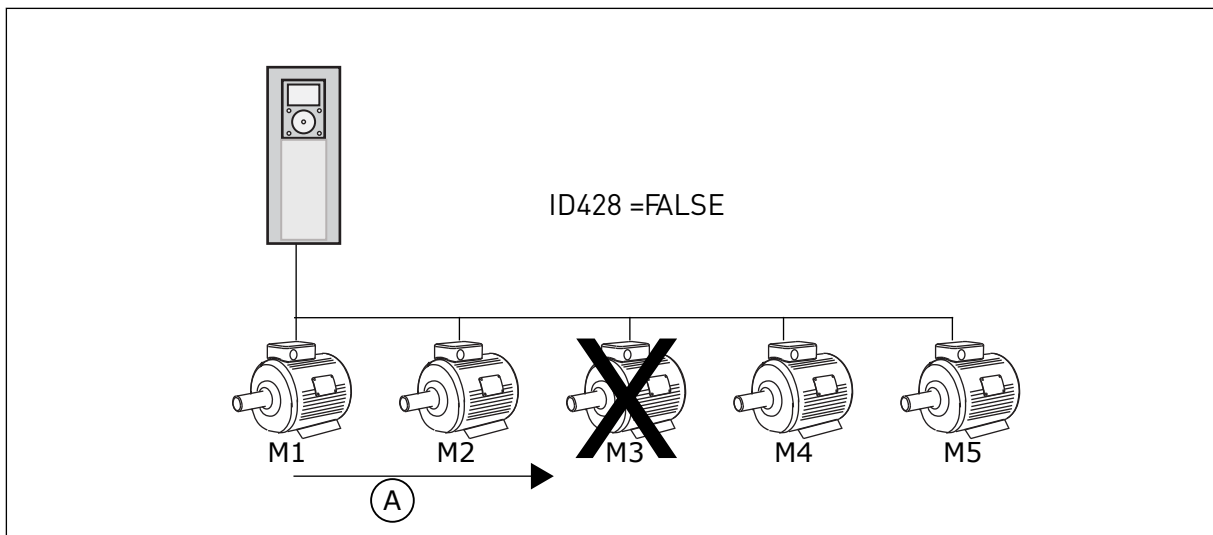

Fig. 82: The interlock logic 2

A. Starting order of motors

If you add Motor 3 again (you set the value of P3.5.1.36 to CLOSED), the system puts Motor 3 last in the sequence: **1, 2, 4, 5, 3**. The system does not stop, but continues to operate.

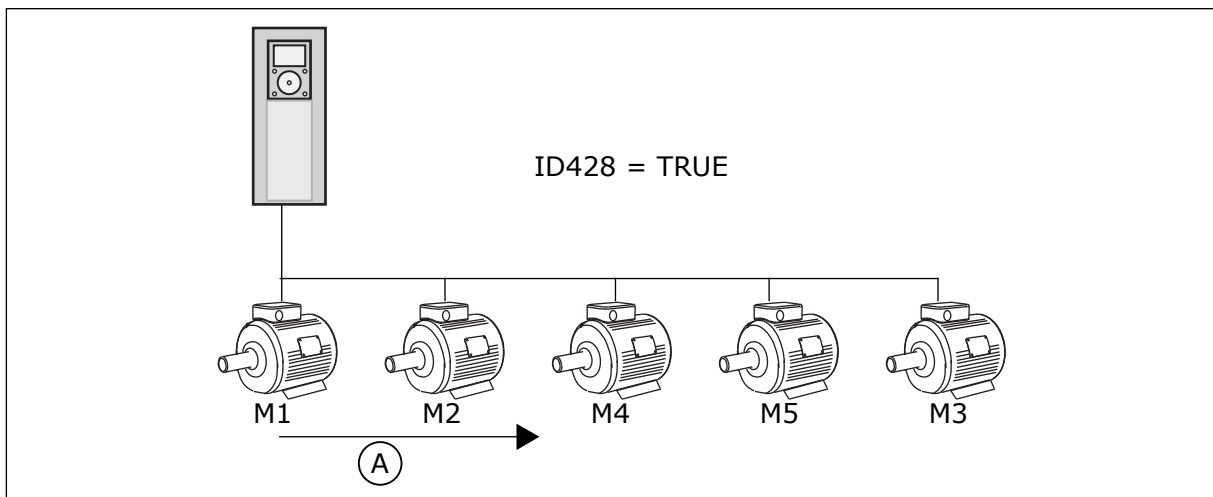

Fig. 83: The interlock logic 3

A. New starting order of motors

When the system stops or goes to sleep mode for the next time, the sequence changes back to **1, 2, 3, 4, 5**.

**P3.15.3 INCLUDE FC (ID 1028)**

Use this parameter to include the controlled motor/pump in the autochange and interlock system.

If the controlled motor/pump not included, the controlling motor is always motor number 1. Please refer to the manual for wiring diagrams in both cases.

Selection number	Selection name	Description
0	Disabled	The drive is always connected to Motor 1. The interlocks do not have an effect on Motor 1. Motor 1 is not included in the autochange logic.
1	Enabled	It is possible to connect the drive to any of the motors in the system. The interlocks have an effect on all the motors. All the motors are included in the autochange logic.

## WIRING

The connections are different for the parameter values *0* and *1*.

### SELECTION *0*, DISABLED

The drive is directly connected to Motor 1. The other motors are auxiliary motors. They are connected to the mains by contactors, and controlled by relays of the drive. The autochange or the interlock logic do not have an effect on Motor 1.

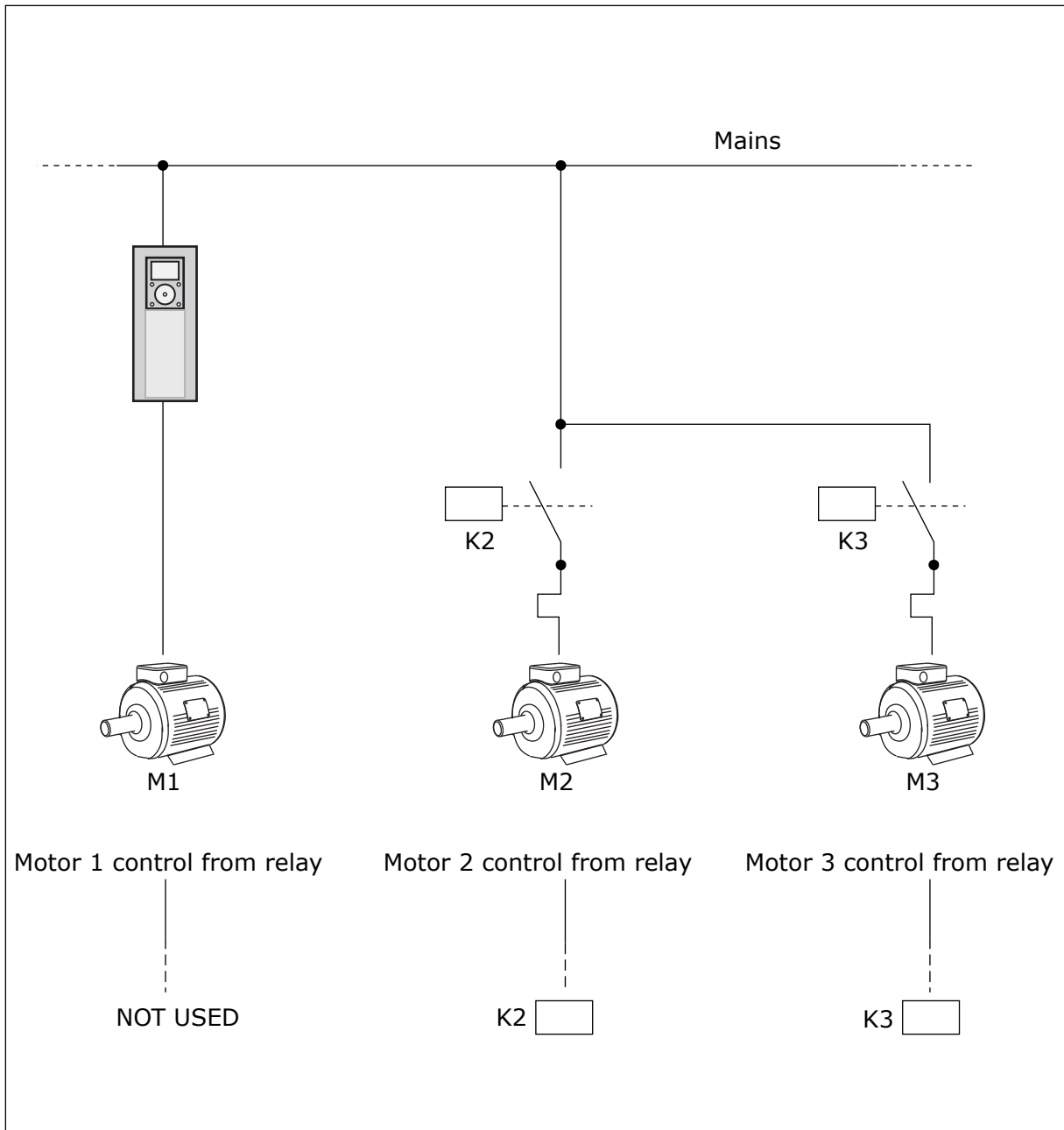

Fig. 84: Selection 0

**SELECTION 1, ENABLED**

To include the regulating motor in the autochange or in the interlock logic, obey the instructions in the figure below. 1 relay controls each motor. The contactor logic always connects the first motor to the drive, and the next motors to the mains.



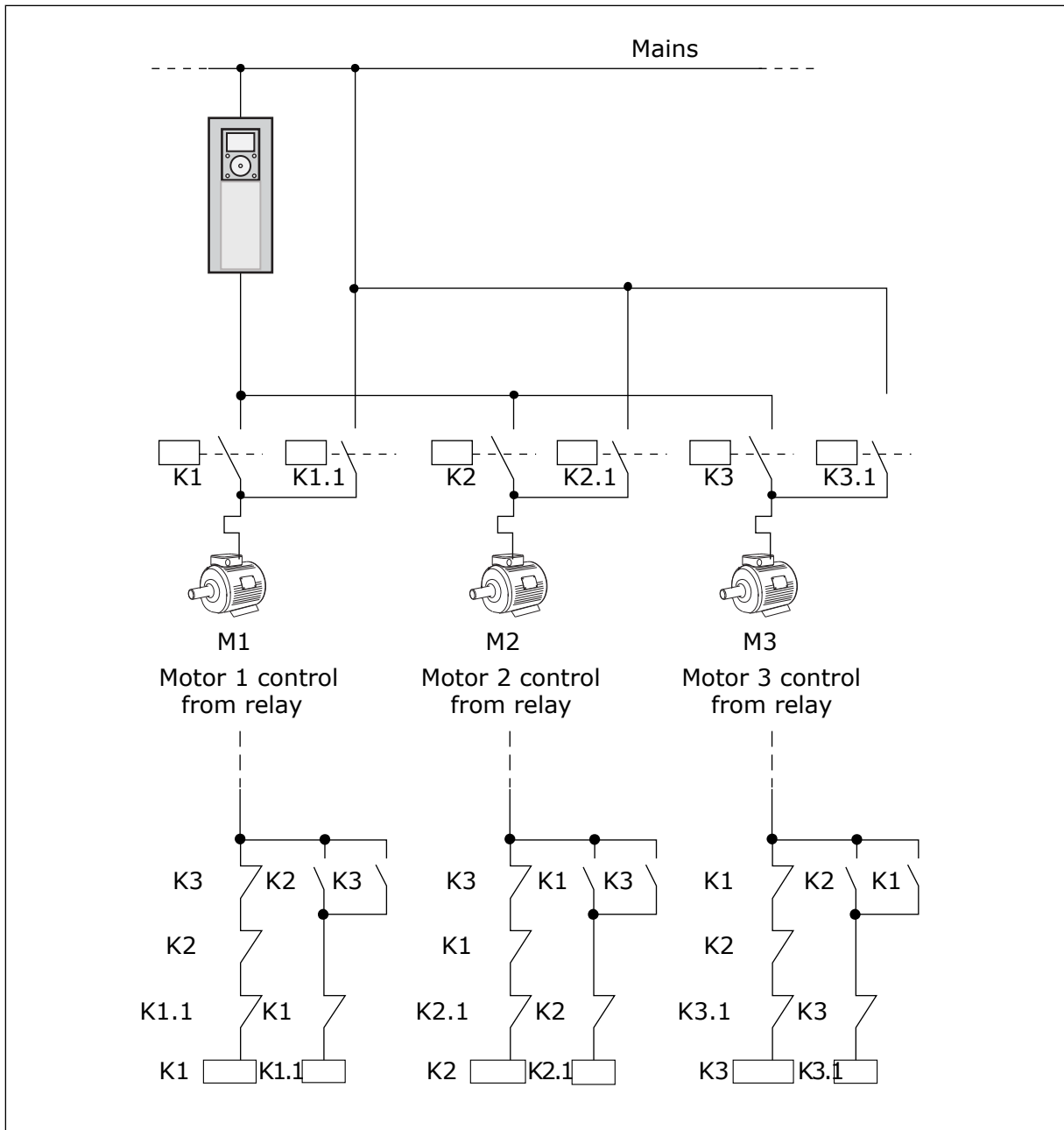

Fig. 85: Selection 1

**P3.15.4 AUTOCHANGE (ID 1027)**

Use this parameter to enable or disable the rotation of the start sequence and the priority of motors.

Selection number	Selection name	Description
0	Disabled	In normal operation, the sequence of the motors is always <b>1, 2, 3, 4, 5</b> . The sequence can change during the operation if you add or remove interlocks. After the drive stops, the sequence always changes back.
1	Enabled	The system changes the sequence at intervals to wear the motors equally. You can adjust the intervals of the autochange.

To adjust the intervals of the autochange, use P3.15.5 Autochange Interval. You can set the maximum number of motors that can operate with parameter Autochange: Motor Limit (P3.15.7). You can also set the maximum frequency of the regulating motor (Autochange: Frequency Limit P3.15.6).

When the process is in the limits that are set with parameters P3.15.6 and P3.15.7, the autochange occurs. If process is not in these limits, the system will wait until the process is in the limits, and do the autochange after that. This prevents sudden pressure drops during the autochange when a high capacity at a pump station is necessary.

#### EXAMPLE

After an autochange, the first motor is put last. The other motors move up 1 position.

The start sequence of the motors: 1, 2, 3, 4, 5

--> Autochange -->

The start sequence of the motors: 2, 3, 4, 5, 1

--> Autochange -->

The start sequence of the motors: 3, 4, 5, 1, 2

#### ***P3.15.5 AUTOCHANGE INTERVAL (ID 1029)***

Use this parameter to adjust the autochange intervals.

This parameter defines how often to rotate the starting order of the motors/pumps. The autochange is done when the number of running motors is below the autochange motor limit and the frequency is below the autochange freq limit.

When the autochange interval has elapsed, the autochange occurs if the capacity is below the level set with P3.15.6. and P3.15.7.

#### ***P3.15.6 AUTOCHANGE: FREQUENCY LIMIT (ID 1031)***

Use this parameter to set the autochange frequency limit.

An autochange is done when the autochange interval has elapsed, the number of running motors is less than autochange motor limit and the controlling drive is running below autochange frequency limit.

#### ***P3.15.7 AUTOCHANGE: MOTOR LIMIT (ID 1030)***

Use this parameter to set the amount of pumps used in Multi-pump function.

An autochange is done when the autochange interval has elapsed, the number of running motors is less than autochange motor limit and the controlling drive is running below autochange frequency limit.

### ***P3.15.8 BANDWIDTH (ID 1097)***

Use this parameter to set the bandwidth area around the PID setpoint for starting and stopping of the auxiliary motors.

When the PID feedback value stays in the bandwidth area, the auxiliary motors does not start or stop. The value of this parameter is given as a percentage of the setpoint.

For example, if setpoint = 5 bar, bandwidth = 10%. When the feedback value stays between 4.5 and 5.5 bar, the motor is not disconnected or removed.

### ***P3.15.9 BANDWIDTH DELAY (ID 1098)***

Use this parameter to set the duration before the auxiliary motors start or stop.

When the PID feedback is outside the bandwidth area, the time that is set with this parameter must elapse before you can add or remove pumps.

### ***P3.15.10 MOTOR 1 INTERLOCK (ID 426)***

Use this parameter to select the digital input signal that is used as interlock signal for the Multi-Pump system.

## **10.16.1 OVERPRESSURE SUPERVISION**

### ***P3.15.16.1 ENABLE OVERPRESSURE SUPERVISION (ID 1698)***

Use this parameter to enable the Overpressure supervision.

If the PID feedback becomes higher than the set overpressure limit, all auxiliary motors stops immediately. Only the regulating motor continues to operate.

You can use the Overpressure supervision function in a Multi-pump system. For example, when you close the primary valve of the pump system quickly, the pressure in the pipe lines increases. The pressure can increase too quickly for the PID controller. To prevent that the pipes break, the overpressure supervision stops the auxiliary motors in the Multi-pump system.

The overpressure supervision monitors the feedback signal of the PID controller, that is, the pressure. If the signal becomes higher than the overpressure level, it stops all the auxiliary pumps immediately. Only the regulating motor continues to operate. When the pressure decreases, the system continues to operate, and connects the auxiliary motors again one at a time.

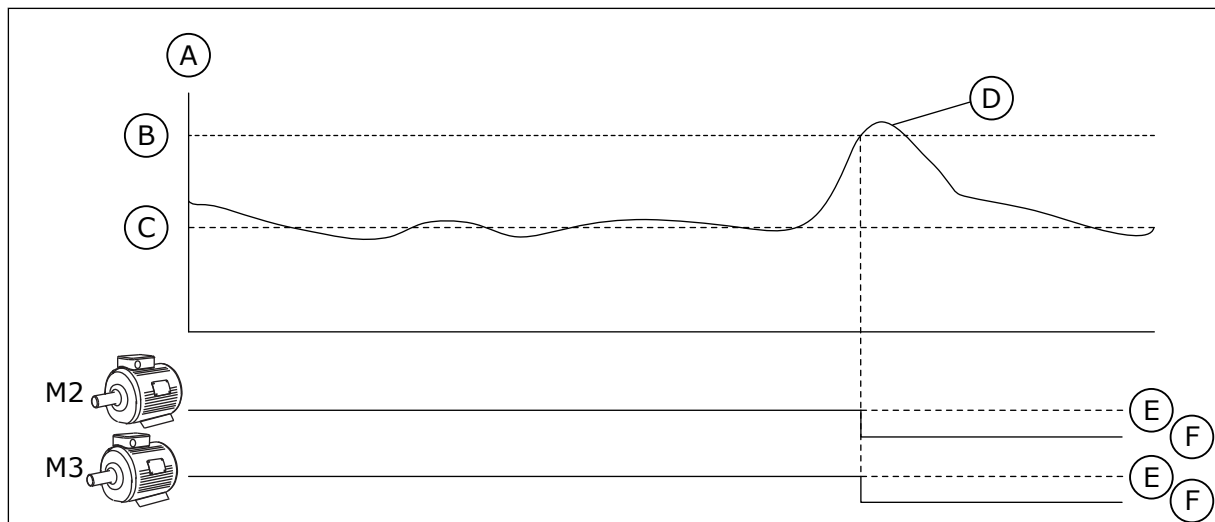

Fig. 86: The Overpressure supervision function

- |                                     |                        |
|-------------------------------------|------------------------|
| A. Pressure                         | D. PID Feedback (ID21) |
| B. Supervision Alarm Level (ID1699) | E. ON                  |
| C. PID Setpoint (ID167)             | F. OFF                 |

### P3.15.16.2 SUPERVISION ALARM LEVEL (ID 1699)

Use this parameter to set the overpressure limit for the Overpressure supervision. If the PID feedback becomes higher than the set overpressure limit, all auxiliary motors stop immediately. Only the regulating motor continues to operate.

## 10.17 MAINTENANCE COUNTERS

A maintenance counter tells you that maintenance must be done. For example, it is necessary to replace a belt or to replace the oil in a gearbox. There are 2 different modes for the maintenance counters, hours or revolutions\*1000. The value of the counters increases only during the RUN status of the drive.



### WARNING!

Do not do maintenance if you are not approved to do it. Only an approved electrician can do maintenance. There is a risk of injury.



### NOTE!

The revolutions mode uses motor speed, which is only an estimate. The drive measures the speed every second.

When the value of a counter is more than its limit, an alarm or a fault shows. You can connect the alarm and fault signals to a digital output or a relay output.

When the maintenance is completed, reset the counter with a digital input or parameter P3.16.4 Counter 1 Reset.

### P3.16.1 COUNTER 1 MODE (ID 1104)

Use this parameter to enable the maintenance counter.

A maintenance counter tells you that the maintenance must be done when the counter value goes above the set limit.

### ***P3.16.2 COUNTER 1 ALARM LIMIT (ID 1105)***

Use this parameter to set the alarm limit for the maintenance counter. When the value of the counter goes above this limit, a maintenance alarm occurs.

### ***P3.16.3 COUNTER 1 FAULT LIMIT (ID 1106)***

Use this parameter to set the fault limit for the maintenance counter. When the value of the counter goes above this limit, a maintenance fault occurs.

### ***P3.16.4 COUNTER 1 RESET (ID 1107)***

Use this parameter to reset the maintenance counter.

### ***P3.16.5 COUNTER 1 DI RESET (ID 490)***

Use this parameter to select the digital input that resets the value of the Maintenance Counter.

## **10.18 FIRE MODE**

When Fire mode is active, the drive resets all faults that occur and continues to operate at the same speed until it is not possible. The drive ignores all commands from the keypad, fieldbuses, and the PC tool. It only obeys the signals Fire Mode Activation, Fire Mode Reverse, Run Enable, Run Interlock 1, and Run Interlock 2 from I/O.

The Fire mode function has 2 modes, the Test mode and the Enabled mode. To make a selection of a mode, write a password in parameter P3.17.1 (Fire Mode Password). In the Test mode, the drive does not automatically reset the faults, and the drive stops when a fault occurs.

It is also possible to configure Fire mode with the Fire mode wizard, which you can activate in the Quick Setup menu with parameter B1.1.4.

When you activate the Fire mode function, an alarm shows on the display.



### **CAUTION!**

The warranty is void if the Fire mode function is activated! You can use Test mode to test the Fire mode function and the warranty stays valid.

### ***P3.17.1 FIRE MODE PASSWORD (ID 1599)***

Use this parameter to enable the Fire Mode function.



### **NOTE!**

All other Fire Mode parameters will be locked when the Fire Mode is enabled and correct password is set in this parameter.

Selection number	Selection name	Description
1002	Enabled mode	The drive resets all the faults and continues to operate at the same speed until it is not possible
1234	Test mode	The drive does not automatically reset the faults, and the drive stops when a fault occurs.

### **P3.17.2 FIRE MODE FREQUENCY SOURCE (ID 1617)**

Use this parameter to select the frequency reference source when the Fire mode is active. This parameter enables the selection of, for example, the AI1 or the PID controller as the reference source when you operate the Fire mode.

### **P3.17.3 FIRE MODE FREQUENCY (ID 1598)**

Use this parameter to set the frequency that is used when Fire mode is active. The drive uses this frequency when the value of parameter P3.17.2 Fire Mode Frequency Source is *Fire Mode Frequency*.

### **P3.17.4 FIRE MODE ACTIVATION ON OPEN (ID 1596)**

Use this parameter to select the digital input signal that activates the Fire Mode function. If this digital input signal is activated, an alarm shows on the display, and the warranty becomes void. The type of this digital input signal is NC (normally closed).

It is possible to try the Fire mode with the password that activates the Test mode. Then the warranty stays valid.



#### **NOTE!**

If Fire mode is enabled, and you give the correct password to the parameter Fire Mode Password, all the Fire mode parameters become locked. To change the Fire mode parameters, change the value of P3.17.1 Fire Mode Password to 0 first.

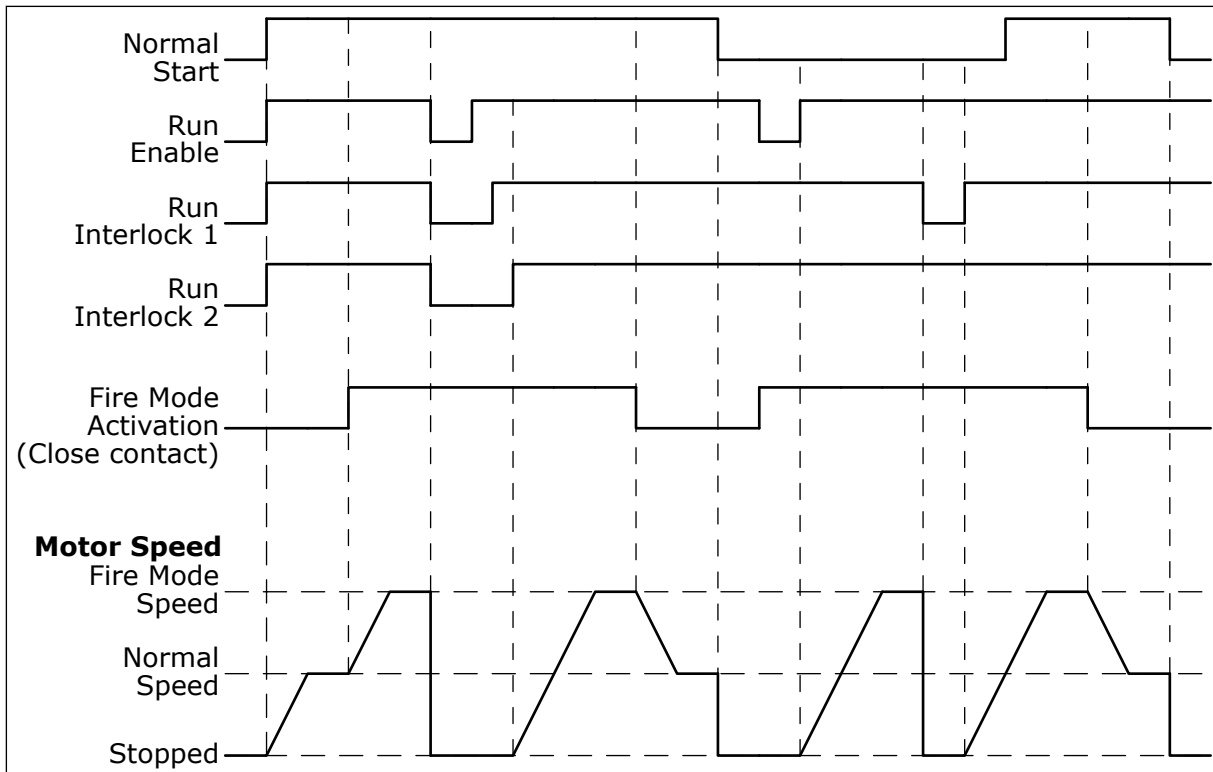

Fig. 87: The Fire mode function

### **P3.17.5 FIRE MODE ACTIVATION ON CLOSE (ID 1619)**

Use this parameter to select the digital input signal that activates the Fire Mode function. The type of this digital input signal is NO (normally open). See the description for P3.17.4 Fire Mode Activation on Open.

### **P3.17.6 FIRE MODE REVERSE (ID 1618)**

Use this parameter to select the digital input signal that gives a command for reverse rotation direction during the Fire Mode. The parameter does not have an effect in normal operation.

If it is necessary for the motor to operate always FORWARD or always REVERSE in Fire Mode, make a selection of the correct digital input.

DigIn Slot0.1 = always FORWARD

DigIn Slot0.2 = always REVERSE

### **V3.17.7 FIRE MODE STATUS (ID 1597)**

This monitoring value shows the status of the Fire mode function.

### **V3.17.8 FIRE MODE COUNTER (ID 1679)**

This monitoring value shows the number of the fire mode activations.

**NOTE!**

You can not reset the counter.

## 10.19 MOTOR PREHEAT FUNCTION

### ***P3.18.1 MOTOR PREHEAT FUNCTION (ID 1225)***

Use this parameter to enable or disable the Motor Preheat function.

The Motor preheat function keeps the drive and the motor warm during the STOP status. In the motor preheat, the system gives the motor a DC current. The motor preheat prevents for example condensation.

Selection number	Selection name	Description
0	Not used	The Motor preheat function is disabled.
1	Always in Stop state	The Motor preheat function is activated always when the drive is in the Stop state.
2	Controlled by digital input	The Motor preheat function is activated by a digital input signal, when the drive is in the Stop state. You can make the selection of the digital input for the activation with parameter P3.5.1.18.
3	Temperature limit (heatsink)	The Motor preheat function is activated if the drive is in the Stop state, and the temperature of the heatsink of the drive goes below the temperature limit that was set with parameter P3.18.2.
4	Temperature limit (measured motor temperature)	The Motor preheat function is activated if the drive is in the Stop state, and the measured motor temperature goes below the temperature limit that was set with parameter P3.18.2. You can set the measurement signal of the motor temperature with parameter P3.18.5.  <b>NOTE!</b> To use this operation mode, you must have an option board for temperature measurement (for example OPT-BH).

### ***P3.18.2 PREHEAT TEMPERATURE LIMIT (ID 1226)***

Use this parameter to set the temperature limit of the Motor Preheat function.

The motor preheat becomes active when the heatsink temperature or the measured motor temperature goes below this level, and when P3.18.1 is set to 3 or 4.

### ***P3.18.3 MOTOR PREHEAT CURRENT (ID 1227)***

Use this parameter to set the DC current of the Motor Preheat function.

The DC current for the pre-heating of the motor and the drive in stop state. Activated as in P3.18.1.



**P3.18.4 MOTOR PREHEAT ON (ID 1044)**

Use this parameter to select the digital input signal that activates Motor Preheat function. This parameter is used when P3.18.1 is set to 2. When the value for P3.18.1 is 2, you can also connect time channels to this parameter.

**P3.18.5 PREHEAT MOTOR TEMPERATURE (ID 1045)**

Use this parameter to select the temperature signal that is used to measure the motor temperature for motor preheat function.

**NOTE!**

This parameter is not available if there is no option board for temperature measurement.

**10.20 DRIVE CUSTOMIZER****P3.19.1 OPERATION MODE (ID 15001)**

Use this parameter to select the operation mode of the drive customizer. When 'Programming' is selected, the execution of the block program is stopped and outputs of the each function block are 0. When 'Execute Program' is selected, the block program is executed and block outputs are updated normally. The Drive Customizer can not be configured when 'Execute Program' is selected. Please use the graphical Drive Customizer tool in Vacon Live.

**10.21 MECHANICAL BRAKE**

You can monitor the mechanical brake with the monitoring value Application Status Word 1 in the monitoring group Extras and advanced.

The Mechanical brake control function controls an external mechanical brake with a digital output signal. The mechanical brake is opened/closed when the drive output frequency breaks the opening/closing limits.

**P3.20.1 BRAKE CONTROL (ID 1541)**

Use this parameter to set the operation mode of the mechanical brake. Mechanical brake status can be supervised via digital input when mode 2 is selected.

**Table 123: The selection of the operation mode of the mechanical brake**

Selection number	Selection name	Description
0	Disabled	The mechanical brake control is not used.
1	Enabled	The mechanical brake control is used, but there is no supervision of the brake status.
2	Enabled with brake status supervision	The mechanical brake control is used, and a digital input signal monitors the brake status (P3.20.8).

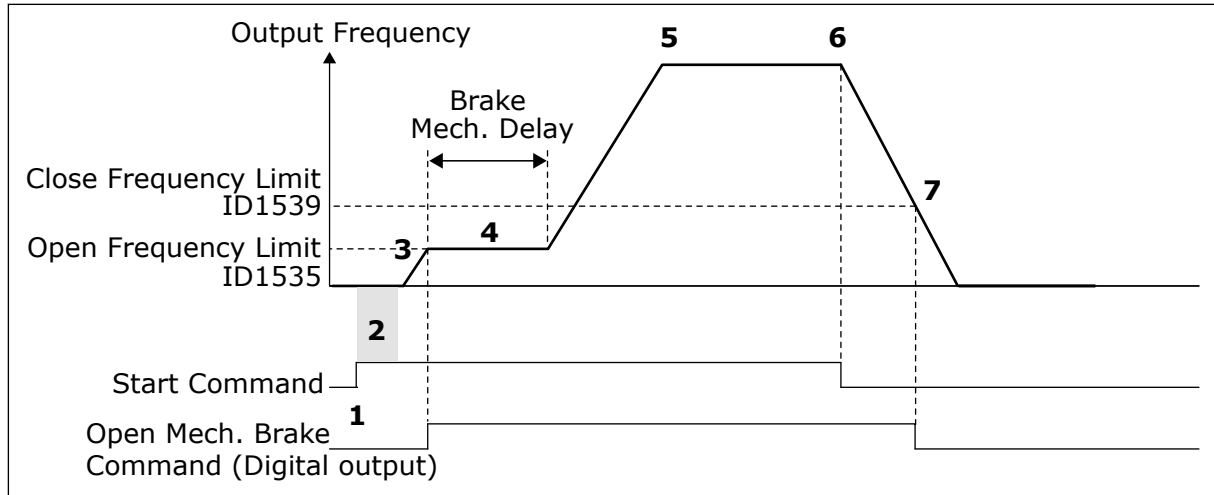
**Fig. 88: The Mechanical brake function**

1. A Start command is given.
2. We recommend that you use start magnetisation to build rotor flux fast and to decrease the time when the motor can produce nominal torque.
3. When the start magnetisation time is over, the system lets the the frequency reference go to the open frequency limit.
4. The mechanical brake opens. The frequency reference stays at the open frequency limit until the brake mechanical delay is over, and the correct brake feedback signal is received.
5. The output frequency of the drive follows the normal frequency reference.
6. A Stop command is given.
7. The mechanical brake becomes closed when the output frequency goes below the close frequency limit.

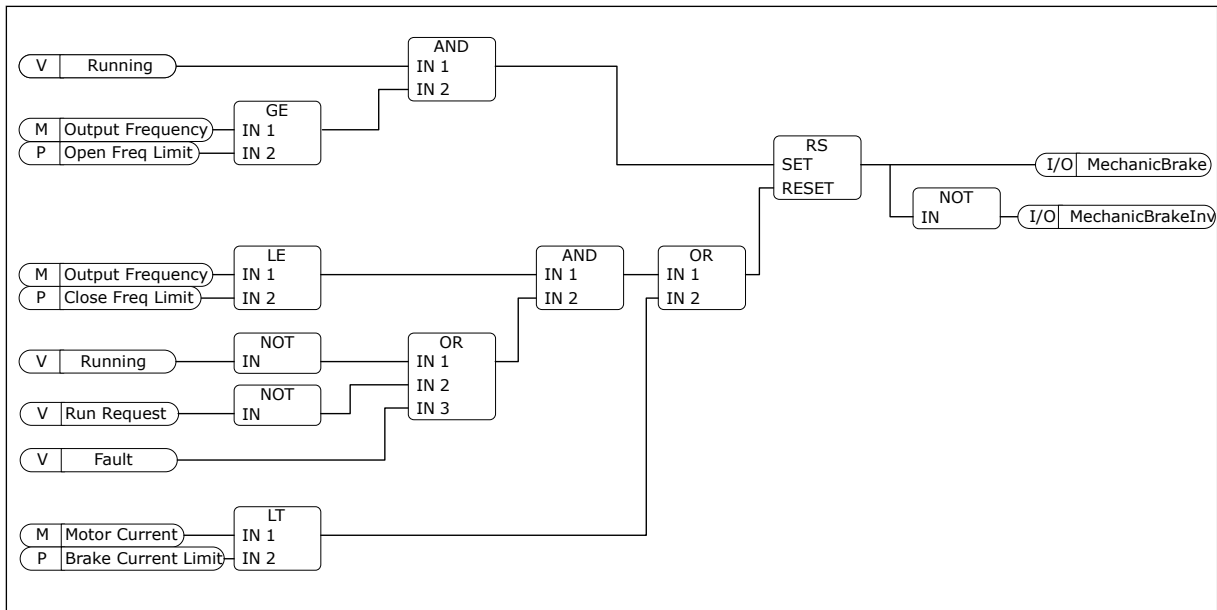

Fig. 89: The mechanical brake opening logic

### **P3.20.2 BRAKE MECHANICAL DELAY (ID 353)**

Use this parameter to set the mechanical delay that is necessary to open the brake. After the brake opening command is given, the speed stays at the value of the parameter P3.20.3 (Brake Opening Frequency Limit) until the brake mechanical delay is expired. Set the delay time to agree with the reaction time of the mechanical brake.

The Brake mechanical delay function is used to prevent current and/or torque spikes. This prevents the motor from operating at full speed against the brake. If you use P3.20.2 at the same time with P3.20.8, it is necessary to have the expired delay and the feedback signal to release the speed reference.

### **P3.20.3 BRAKE OPENING FREQUENCY LIMIT (ID 1535)**

Use this parameter to set the frequency limit for opening the mechanical brake. The value of the parameter P3.20.3 is the output frequency limit of the drive to open the mechanical brake. In open loop control, we recommend that you use a value that is equal to the nominal slip of the motor.

The output frequency of the drive stays at this level until the brake mechanical delay is expired, and the system receives the correct brake feedback signal.

### **P3.20.4 BRAKE CLOSING FREQUENCY LIMIT (ID 1539)**

Use this parameter to set the frequency limit for closing the mechanical brake. The value of the parameter P3.20.4 is the output frequency limit of the drive to close the mechanical brake. The drive stops and the output frequency goes near 0. You can use the parameter for the 2 directions, positive and negative.

### **P3.20.5 BRAKE CURRENT LIMIT (ID 1085)**

Use this parameter to set the brake current limit.

The Mechanical brake closes immediately if the motor current is below the limit set in parameter Brake Current Limit. We recommend that you set the value to approximately half of the magnetisation current.

When the drive operates on the field weakening area, the brake current limit decreases automatically as a function of output frequency.

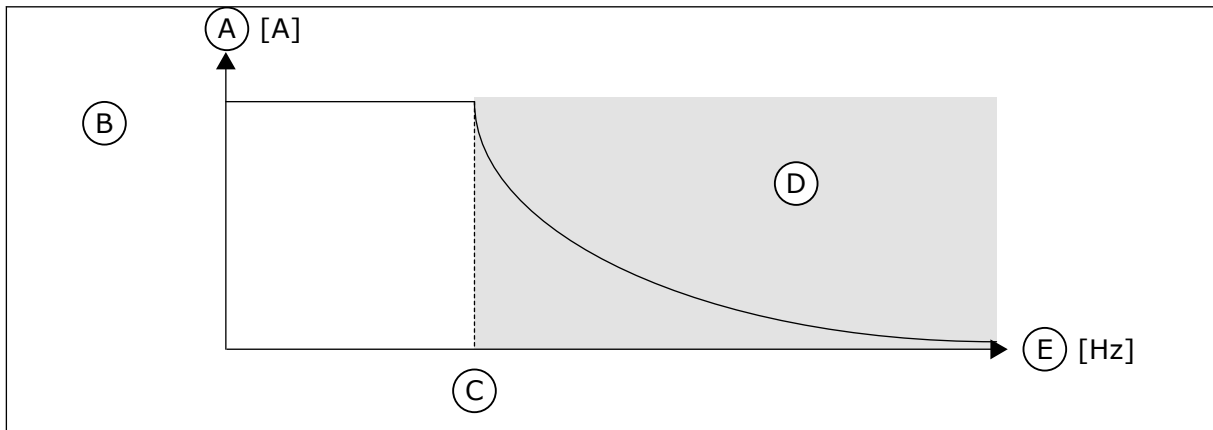

Fig. 90: Internal reduction of the brake current limit

- |                                  |                         |
|----------------------------------|-------------------------|
| A. Current                       | D. Field weakening area |
| B. Brake current limit (ID1085)  | E. Output frequency     |
| C. Field weakening point (ID602) |                         |

### P3.20.6 BRAKE FAULT DELAY (ID 352)

Use this parameter to set the brake fault delay time.

If the correct brake feedback signal is not received during this delay, a fault shows. This delay is only used if the value of P3.20.1 is set to 2.

### P3.20.7 RESPONSE TO BRAKE FAULT (ID 1316)

Use this parameter to set the response type to a brake fault.

### P3.20.8 (P3.5.1.44) BRAKE FEEDBACK (ID 1210)

Use this parameter to set the brake status feedback signal from mechanical brake. The Brake feedback signal is used if the value for parameter P3.20.1 is *Enabled with brake status supervision*.

Connect this digital input signal to an auxiliary contact of the mechanical brake.

The **contact** is open = the mechanical brake is closed

The **contact** is closed = the mechanical brake is open

If the brake opening command is given, but the contact of the brake feedback signal does not close in given time, a mechanical brake fault shows (fault code 58).

## 10.22 PUMP CONTROL

### 10.22.1 AUTO-CLEANING

Use the Auto-cleaning function to remove dirt or other material from the pump impeller. You can also use the function to clear a blocked pipe or valve. You can use the auto-cleaning, for example, in wastewater systems to keep the performance of the pump satisfactory.

#### ***P3.21.1.1 CLEANING FUNCTION (ID 1714)***

Use this parameter to enable the Auto-cleaning function. If you enable the parameter Cleaning Function, the auto-cleaning starts, and activates the digital input signal in parameter P3.21.1.2.

#### ***P3.21.1.2 CLEANING ACTIVATION (ID 1715)***

Use this parameter to select the digital input signal that starts the Auto-cleaning sequence. The auto-cleaning stops if the activation signal is removed before the sequence is complete.



#### **NOTE!**

If the input is activated, the drive starts.

#### ***P3.21.1.3 CLEANING CYCLES (ID 1716)***

Use this parameter to set the number of forward or reverse cleaning cycles.

#### ***P3.21.1.4 CLEAN FORWARD FREQUENCY (ID 1717)***

Use this parameter to set the frequency reference of the drive for the forward direction in the Auto-cleaning cycle.

You can set the frequency and time of the cleaning cycle with the parameters P3.21.1.4, P3.21.1.5, P3.21.1.6 and P3.21.1.7.

#### ***P3.21.1.5 CLEAN FORWARD TIME (ID 1718)***

Use this parameter to set the operation time for the forward direction frequency in the Auto-cleaning cycle.

See parameter P3.21.1.4 Clean Forward Frequency.

#### ***P3.21.1.6 CLEAN REVERSE FREQUENCY (ID 1719)***

Use this parameter to set the frequency reference of the drive for the reverse direction in the Auto-cleaning cycle.

See parameter P3.21.1.4 Clean Forward Frequency.

#### ***P3.21.1.7 CLEAN REVERSE TIME (ID 1720)***

Use this parameter to set the operation time for the reverse direction frequency in the Auto-cleaning cycle.

See parameter P3.21.1.4 Clean Forward Frequency.

**P3.21.1.8 CLEANING ACCELERATION TIME (ID 1721)**

Use this parameter to set the motor acceleration time when the Auto-cleaning is active. You can set acceleration and deceleration ramps for the Auto-cleaning function with parameters P3.21.1.8 and P3.21.1.9.

**P3.21.1.9 CLEANING DECELERATION TIME (ID 1722)**

Use this parameter to set the motor deceleration time when the Auto-cleaning is active. You can set acceleration and deceleration ramps for the Auto-cleaning function with parameters P3.21.1.8 and P3.21.1.9.

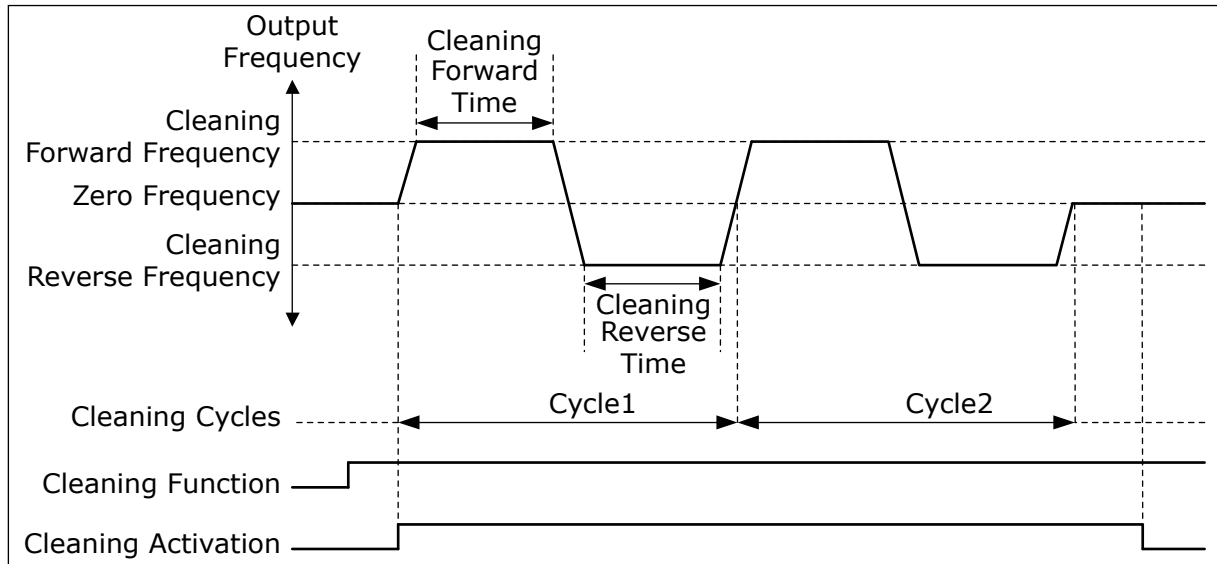

Fig. 91: The Auto-cleaning function

**10.22.2 JOCKEY PUMP**

**P3.21.2.1 JOCKEY FUNCTION (ID 1674)**

Use this parameter to control the Jockey pump function. A Jockey pump is a smaller pump that keeps the pressure in the pipeline, when the main pump is in the sleep mode. This can occur, for example, in the night.

The Jockey pump function controls a jockey pump with a digital output signal. You can use a jockey pump if a PID controller is used to control the main pump. The function has 3 operation modes.

Selection number	Selection name	Description
0	Not used	
1	PID sleep	The jockey pump starts when the PID Sleep of the main pump activates. The jockey pump stops when the main pump wakes up from the sleep mode.
2	PID sleep (level)	The jockey pump starts when the PID Sleep activates, and the PID feedback signal is less than the level set by parameter P3.21.2.2. The jockey pump stops when the PID feedback signal is more than the level set in parameter P3.21.2.3 or the main pump wakes up from the sleep mode.

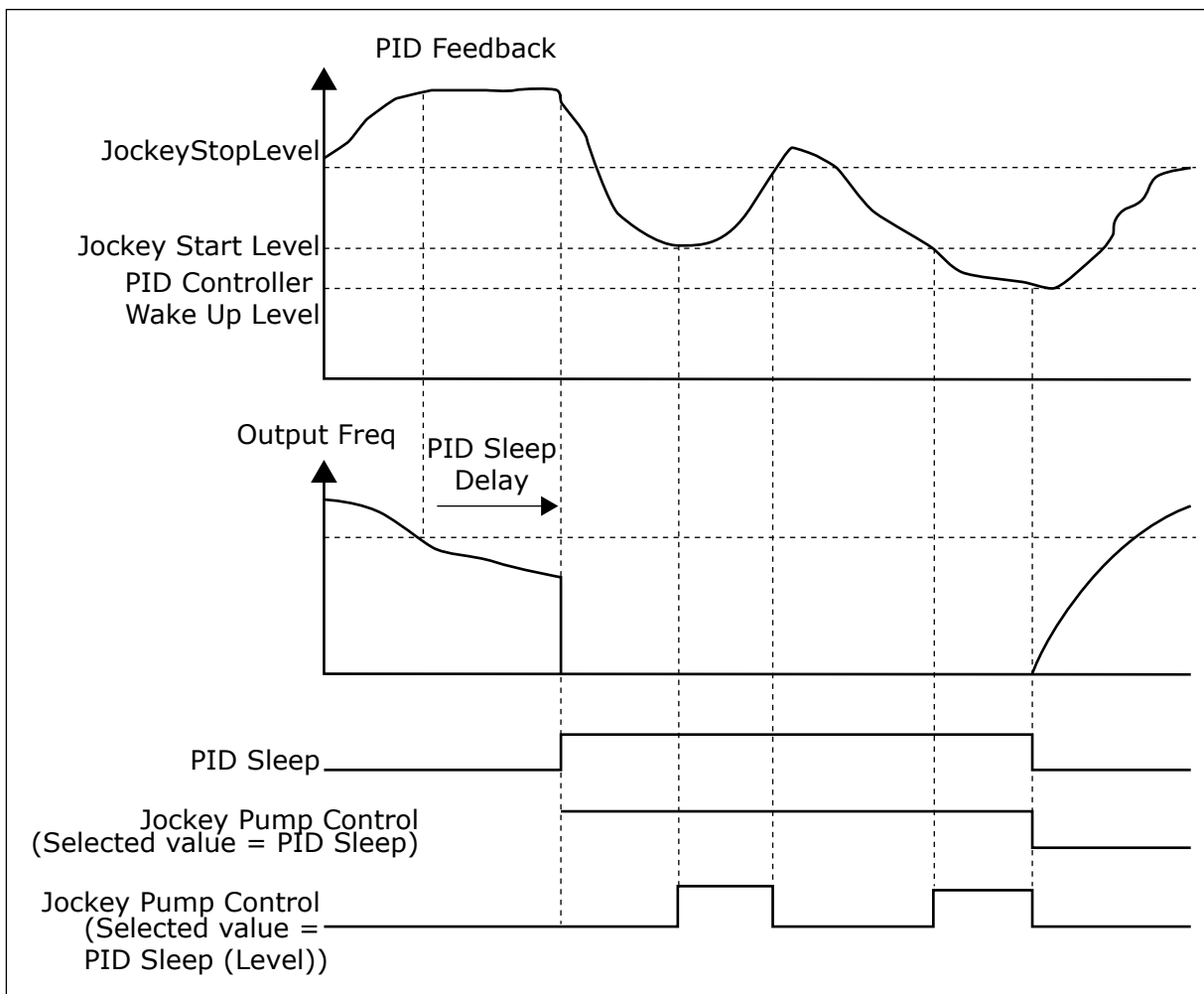

Fig. 92: The Jockey pump function

**P3.21.2.2 JOCKEY START LEVEL (ID 1675)**

Use this parameter to set the level of the PID feedback signal at which the jockey pump starts when the main pump is in the sleep state. The jockey pump starts when PID Sleep is active and the PID feedback signal goes below the level set in this parameter.

**NOTE!**

This parameter is used only if P3.21.2.1 = 2 PID sleep (level).

**P3.21.2.3 JOCKEY STOP LEVEL (ID 1676)**

Use this parameter to set the level of the PID feedback signal at which the jockey pump stops when the main pump is in the sleep state.

The jockey pump stops when PID Sleep is active and the PID feedback signal goes above the level set in this parameter, or when the PID controller wakes up from sleep mode.

**NOTE!**

This parameter is used only if P3.21.2.1 = 2 PID sleep (level).

**10.22.3 PRIMING PUMP**

A priming pump is a smaller pump that primes the inlet of the main pump to prevent suction of air.

The priming pump function controls a priming pump with a digital output signal. You can set a delay to start the priming pump before the main pump starts. The priming pump operates continuously while the main pump operates.

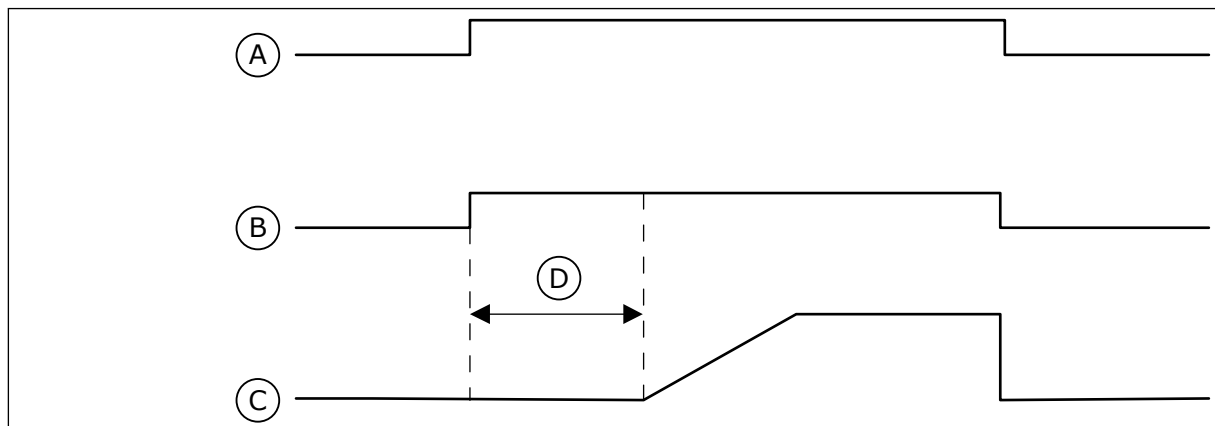

Fig. 93: The Priming pump function

- |                                                 |                            |
|-------------------------------------------------|----------------------------|
| A. Start Command (Main Pump)                    | C. Output Freq (Main Pump) |
| B. Priming Pump Control (Digital Output Signal) | D. Priming Time            |

**P3.21.3.1 PRIMING FUNCTION (ID 1677)**

Use this parameter to enable the Priming pump function.

A priming pump is a smaller pump that primes the inlet of the main pump to prevent the suction of air. The priming pump function controls a priming pump with a relay output signal.

**P3.21.3.2 PRIMING TIME (ID 1678)**

Use this parameter to set the time that the priming pump operates before the main pump starts.



# 11 FAULT TRACING

When the control diagnostics of the AC drive find an unusual condition in the operation of the drive, the drive shows a notification about it. You can see the notification on the display of the control panel. The display shows the code, the name and a short description of the fault or alarm.

The source info tells you the source of the fault, what caused it, where it occurred, and other data.

### There are 3 different types of notification.

- An info does not have an effect the operation of the drive. You must reset the info.
- An alarm informs you of unusual operation on the drive. It does not stop the drive. You must reset the alarm.
- A fault stops the drive. You must reset the drive and find a solution to the problem.

You can program different responses for some faults in the application. See more in Chapter 5.9 Group 3.9: Protections.

Reset the fault with the Reset button on the keypad, or through the I/O terminal, fieldbus or the PC tool. The faults stay in the Fault history where you can go and examine them. See the different fault codes in Chapter 11.3 Fault codes.

Before you contact the distributor or the factory because of unusual operation, prepare some data. Write down all the texts on the display, the fault code, the fault ID, the source info, the Active Faults list and the Fault History.

## 11.1 A FAULT COMES INTO VIEW

When the drive shows a fault and stops, examine the cause of fault, and reset the fault.

There are 2 procedures to reset a fault: with the Reset button and with a parameter.

### RESETTING WITH THE RESET BUTTON

- 1 Push the Reset button on the keypad for 2 secods.

### RESETTING WITH A PARAMETER IN THE GRAPHICAL DISPLAY

- 1 Go to the Diagnostics Menu.

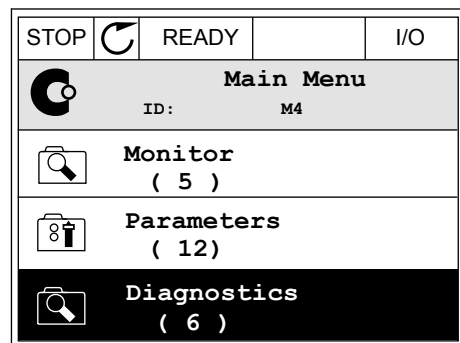

- Go to the submenu Reset faults.

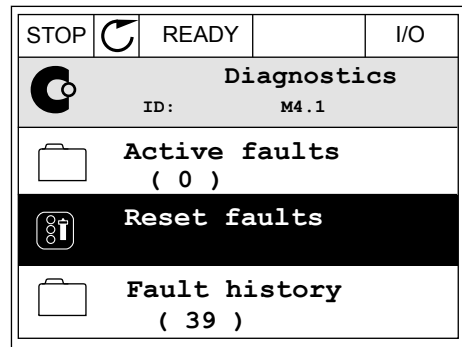

- Make a selection of the parameter Reset Faults.

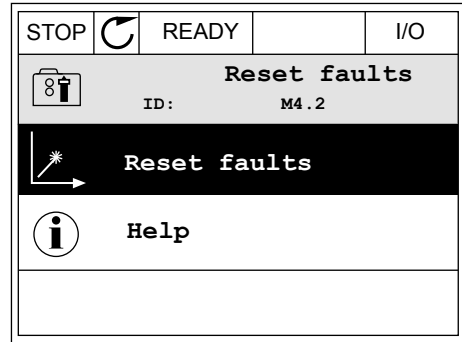

**RESETTING WITH A PARAMETER IN THE TEXT DISPLAY**

- Go to the Diagnostics menu.



- Use the arrow buttons Up and Down to find the parameter Reset Faults.

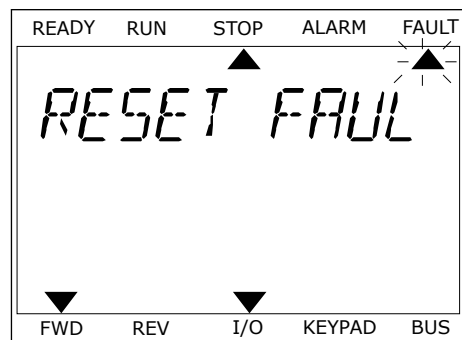

- 3 Make a selection of the value Yes and push OK.

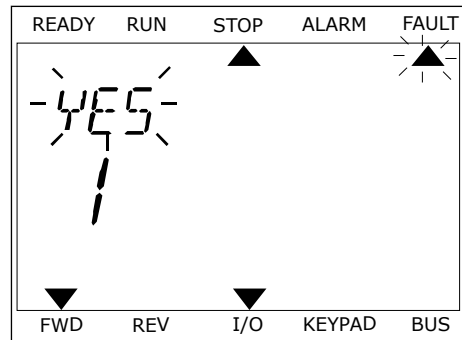

## 11.2 FAULT HISTORY

In the Fault history, you can find more data on the faults. There is a maximum number of 40 faults in the Fault history.

### EXAMINING THE FAULT HISTORY IN THE GRAPHICAL DISPLAY

- 1 To see more data on a fault, go to Fault history.

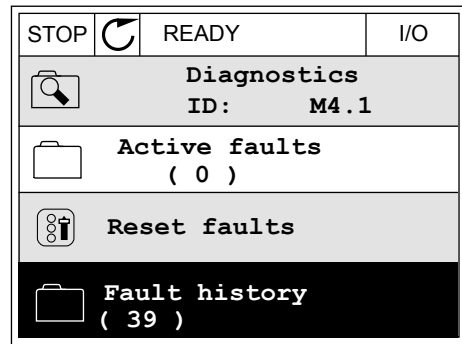

- 2 To examine the data of a fault, push the Arrow button Right.

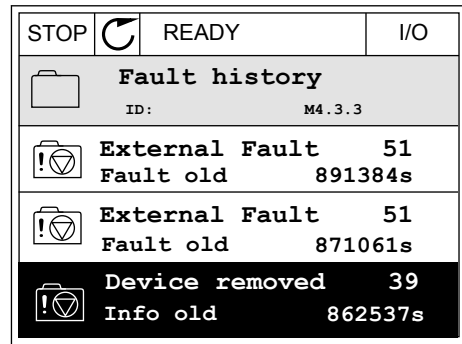

- You see the data in a list.

STOP	READY	I/O
<b>Fault history</b>		
ID:		M4.3.3.2
Code	39	
ID	380	
State	Info old	
Date	7.12.2009	
Time	04:46:33	
Operating time	862537s	
Source 1		
Source 2		
Source 3		

**EXAMINING THE FAULT HISTORY IN THE TEXT DISPLAY**

- Push OK to go to Fault history.

READY	RUN	STOP	ALARM	FAULT
▲				
FAULT HIST				
M4.3				
▼				
FWD	REV	I/O	KEYPAD	BUS

- To examine the data of a fault, push OK again.

READY	RUN	STOP	ALARM	FAULT
▲				
COMMUNICAT				
M4.3 1				
▼				
FWD	REV	I/O	KEYPAD	BUS

3 Use the arrow button down to examine all the data.

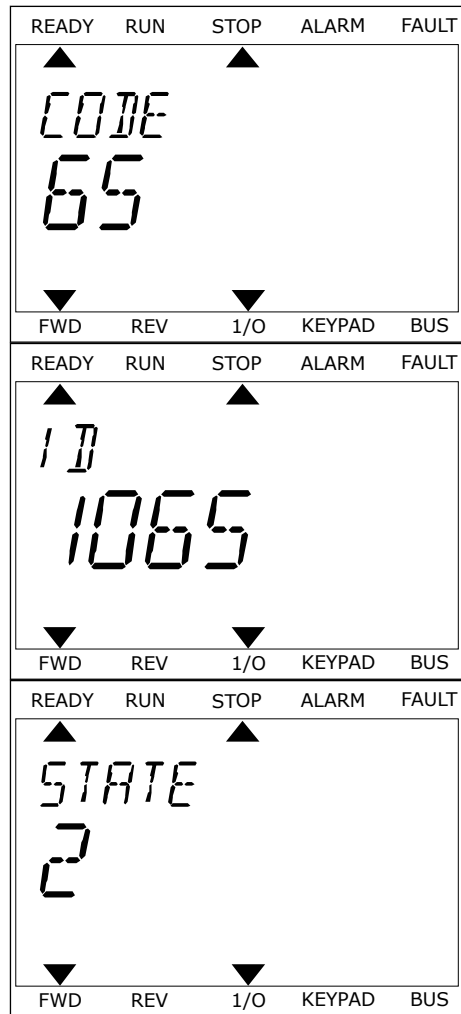

### 11.3 FAULT CODES

Fault code	Fault ID	Fault name	Possible cause	How to correct the fault
1	1	Overcurrent (hardware fault)	<p>There is too high a current (<math>&gt;4 \cdot I_H</math>) in the motor cable. Its cause can be 1 of these.</p> <ul style="list-style-type: none"> <li>a sudden heavy load increase</li> <li>a short circuit in the motor cables</li> <li>the motor is not the correct type</li> <li>the parameter settings are not properly made</li> </ul>	<p>Do a check of the loading. Do a check of the motor. Do a check of the cables and connections. Make an identification run. Set the acceleration time longer (P3.4.1.2 and P3.4.2.2).</p>
	2	Overcurrent (software fault)		
2	10	Overvoltage (hardware fault)	<p>The DC-link voltage is higher than the limits.</p> <ul style="list-style-type: none"> <li>too short a deceleration time</li> <li>high overvoltage spikes in the supply</li> </ul>	<p>Set the deceleration time longer (P3.4.1.3 and P3.4.2.3). Use the brake chopper or the brake resistor. They are available as options. Activate the overvoltage controller. Do a check of the input voltage.</p>
	11	Overvoltage (software fault)		
3	20	Earth fault (hardware fault)	<p>The measurement of current tells that the sum of the motor phase current is not zero.</p> <ul style="list-style-type: none"> <li>an insulation malfunction in the cables or the motor</li> <li>a filter (du/dt, sinus) malfunction</li> </ul>	<p>Do a check of the motor cables and the motor. Do a check of the filters.</p>
	21	Earth fault (software fault)		
5	40	Charging switch	<p>The charging switch is closed and the feedback information is OPEN.</p> <ul style="list-style-type: none"> <li>operation malfunction</li> <li>defective component</li> </ul>	<p>Reset the fault and restart the drive. Do a check of the feedback signal and the cable connection between the control board and the power board. If the fault occurs again, ask instructions from the distributor near to you.</p>
7	60	Saturation	<ul style="list-style-type: none"> <li>Defective IGBT</li> <li>de-saturation short circuit in the IGBT</li> <li>a short circuit or an overload in the brake resistor</li> </ul>	<p>This fault cannot be reset from the control panel. Switch off the power. <b>DO NOT RESTART THE DRIVE or CONNECT THE POWER!</b> Ask instructions from the factory.</p>

Fault code	Fault ID	Fault name	Possible cause	How to correct the fault
8	600	System fault	There is no communication between the control board and the power.	Reset the fault and restart the drive. Download the latest software from the Vacon website. Update the drive with it. If the fault occurs again, ask instructions from the distributor near to you.
	601		Defective component. Operation malfunction.	
	602		Defective component. Operation malfunction. The voltage of auxiliary power in the power unit is too low.	
	603		Defective component. Operation malfunction. Output phase voltage does not agree to the reference. Feedback fault.	
	604		Defective component. Operation malfunction.	
	605		The software of the control unit is not compatible with the software of the power unit.	
	606		The software version cannot be read. There is no software in the power unit. Defective component. Operation malfunction (a problem in the power board or the measurement board).	
	607		A CPU overload.	
	608		Defective component. Operation malfunction.	Reset the fault and make a power down of the drive twice. Download the latest software from the Vacon website. Update the drive with it.

Fault code	Fault ID	Fault name	Possible cause	How to correct the fault
8	610	System fault	Defective component. Operation malfunction.	Reset the fault and restart. Download the latest software from the Vacon website. Update the drive with it. If the fault occurs again, ask instructions from the distributor near to you.
	614		Configuration error. Software error. Defective component (a defective control board). Operation malfunction.	
	647		Defective component. Operation malfunction.	
	648		Operation malfunction. The system software is not compatible with the application.	
	649		A resource overload. A parameter loading, restoring or saving malfunction.	Load the factory default settings. Download the latest software from the Vacon website. Update the drive with it.
9	80	Undervoltage (fault)	<p>The DC-link voltage is lower than the limits.</p> <ul style="list-style-type: none"> <li>• too low a supply voltage</li> <li>• defective component</li> <li>• a defective input fuse</li> <li>• the external charge switch is not closed</li> </ul> <p><b>NOTE!</b></p> <p>This fault becomes active only if the drive is in Run state.</p>	<p>If there is a temporary supply voltage break, reset the fault and restart the drive.</p> <p>Do a check of the supply voltage. If the supply voltage is sufficient, there is an internal fault.</p> <p>Examine the electrical network for fault.</p> <p>Ask instructions from the distributor near to you.</p>
10	91	Input phase	<ul style="list-style-type: none"> <li>• supply voltage malfunction</li> <li>• a defective fuse or malfunction in the supply cables</li> </ul> <p>The load must be a minimum of 10-20% for the supervision to work.</p>	Do a check of the supply voltage, the fuses and supply cable, the rectifying bridge and the gate control of the thyristor (MR6->).



Fault code	Fault ID	Fault name	Possible cause	How to correct the fault
11	100	Output phase supervision	<p>The measurement of current tells that there is no current in 1 motor phase.</p> <ul style="list-style-type: none"> <li>a motor or motor cables malfunction</li> <li>filter (du/dt, sinus) malfunction</li> </ul>	<p>Do a check of the motor cable and the motor.</p> <p>Do a check of the du/dt or sinus filter.</p>
12	110	Brake chopper supervision (hardware fault)	<p>There is no brake resistor. The brake resistor is broken. A defective brake chopper.</p>	<p>Do a check of the brake resistor and the cabling.</p> <p>If they are in good condition, there is a fault in the resistor or the chopper. Ask instructions from the distributor near to you.</p>
	111	Brake chopper saturation alarm		
13	120	AC drive undertemperature (fault)	<p>Too low a temperature in the heatsink of the power unit or in the power board.</p>	<p>The ambient temperature is too low for the drive. Move the drive in a warmer position.</p>
14	130	AC drive overtemperature (fault, heatsink)	<p>Too high a temperature in the heatsink of the power unit or in the power board. The temperature limits of the heatsink are different in all the frames.</p>	<p>Do a check of the actual amount and flow of cooling air. Examine the heatsink for dust. Do a check of the ambient temperature. Make sure that the switching frequency is not too high in relation to the ambient temperature and the motor load. Do a check of the cooling fan.</p>
	131	AC drive overtemperature (alarm, heat-sink)		
	132	AC drive overtemperature (fault, board)		
	133	AC drive overtemperature (alarm, board)		
15	140	Motor stall	<p>The motor stalled.</p>	<p>Do a check of the motor and the load.</p>
16	150	Motor overtemperature	<p>There is too heavy a load on the motor.</p>	<p>Decrease the motor load. If there is no motor overload, do a check of the motor thermal protection parameters (parameter group 3.9 Protections).</p>
17	160	Motor underload	<p>There is not a sufficient load on the motor.</p>	<p>Do a check of the load. Do a check of the parameters. Do a check of the du/dt and sinus filters.</p>
19	180	Power overload (short-time supervision)	<p>The power of the drive is too high.</p>	<p>Decrease the load. Examine the dimensions of drive. Examine if it is too small for the load.</p>
	181	Power overload (long-time supervision)		

Fault code	Fault ID	Fault name	Possible cause	How to correct the fault
25	240	Motor control fault	<p>This fault is available only if you use a customer-specific application. A malfunction in the start angle identification.</p> <ul style="list-style-type: none"> <li>• The rotor moves during identification.</li> <li>• The new angle does not agree with the old value.</li> </ul>	<p>Reset the fault and restart the drive. Increase the identification current. See the fault history source for more information.</p>
	241			
26	250	Start-up prevented	It is not possible to do a start-up of the drive. When the Run request is ON, a new software (a firmware or an application), a parameter setting or other file that effects the operation of the drive, is loaded to drive.	Reset the fault and stop the drive. Load the software and start the drive.
29	280	Atex thermistor	The ATEX thermistor tells that there is an overtemperature.	Reset the fault. Do a check of the thermistor and its connections.

Fault code	Fault ID	Fault name	Possible cause	How to correct the fault
30	290	Safe Off	The safe Off signal A does not let you to set the drive to the READY state.	Reset the fault and restart the drive. Do a check of the signals from the control board to the power unit and the D connector.
	291	Safe Off	The safe Off signal B does not let you to set the drive to the READY state.	
	500	Safety configuration	The safety configuration switch was installed.	Remove the safety configuration switch from the control board.
	501	Safety configuration	There are too many STO option boards. It is possible to have only 1.	Keep 1 of the STO option boards. Remove the others. See the safety manual.
	502	Safety configuration	The STO option board was installed in an incorrect slot.	Put the STO option board into the correct slot. See the safety manual.
	503	Safety configuration	There is no safety configuration switch on the control board.	Install the safety configuration switch on the control board. See the safety manual.
	504	Safety configuration	The safety configuration switch was installed incorrectly on the control board.	Install the safety configuration switch into the correct position on the control board. See the safety manual.
	505	Safety configuration	The safety configuration switch was installed incorrectly on the STO option board.	Do a check of the installation of the safety configuration switch on the STO option board. See the safety manual.
	506	Safety configuration	There is no communication with the STO option board.	Do a check of the installation of the STO option board. See the safety manual.
	507	Safety configuration	The STO option board is not compatible with the hardware.	Reset the drive and restart it. If the fault occurs again, ask instructions from your nearest distributor.

Fault code	Fault ID	Fault name	Possible cause	How to correct the fault
30	520	Safety diagnostics	The STO inputs have a different status.	Do a check of the external safety switch. Do a check of the input connection and cable of the safety switch. Reset the drive and restart. If the fault occurs again, ask instructions from your nearest distributor.
	521	Safety diagnostics	A malfunction in the ATEX thermistor diagnostic. There is no connection in the ATEX thermistor input.	Reset the drive and restart. If the fault occurs again, change the option board.
	522	Safety diagnostics	A short-circuit in the connection of the ATEX thermistor input.	Do a check of the ATEX thermistor input connection. Do a check of the external ATEX connection. Do a check of the external ATEX thermistor.
	523	Safety diagnostics	A problem occurred in the internal safety circuit.	Reset the drive and restart. If the fault occurs again, ask instructions from your nearest distributor.
	524	Safety diagnostics	An overvoltage in the safety option board	Reset the drive and restart. If the fault occurs again, ask instructions from your nearest distributor.
	525	Safety diagnostics	An undervoltage in the safety option board	Reset the drive and restart. If the fault occurs again, ask instructions from your nearest distributor.
	526	Safety diagnostics	An internal malfunction in the safety option board CPU or in the memory handling	Reset the drive and restart. If the fault occurs again, ask instructions from your nearest distributor.
	527	Safety diagnostics	An internal malfunction in the safety function	Reset the drive and restart. If the fault occurs again, ask instructions from your nearest distributor.
	530	Safe torque off	An emergency stop was connected or some other STO operation was activated.	When the STO function is activated, the drive is in safe state.

Fault code	Fault ID	Fault name	Possible cause	How to correct the fault
32	311	Fan cooling	The fan speed does not agree to the speed reference accurately, but the drive operates correctly. This fault shows only in the MR7 and in the drives that bigger than MR7.	Reset the fault and restart the drive. Clean or replace the fan.
	312	Fan cooling	The fan life time (that is, 50,000 h) is complete.	Replace the fan and reset the life time counter of the fan.
33	320	Fire mode enabled	The Fire mode of the drive is enabled. The protections of the drive are not used. This alarm is reset automatically when Fire mode is disabled.	Do a check of the parameter settings and the signals. Some of the protections of the drive are disabled.
37	361	Device changed (same type)	The power unit was replaced by a new one that has the same size. The device is ready to be used. The parameters are available in the drive.	Reset the fault. The drive reboots after you reset the fault.
	362	Device changed (same type)	The option board in slot B was replaced by a new one that you have used before in the same slot. The device is ready to be used.	Reset the fault. The drive starts to use the old parameter settings.
	363	Device changed (same type)	The same cause as in ID362, but refers to Slot C.	
	364	Device changed (same type)	The same cause as in ID362, but refers to Slot D.	
	365	Device changed (same type)	The same cause as in ID362, but refers to Slot E.	
38	372	Device added (same type)	An option board was put into slot B. You have used the option board before in the same slot. The device is ready to be used.	The device is ready for use. The drive starts to use the old parameter settings.
	373	Device added (same type)	The same cause as in ID372, but refers to Slot C.	
	374	Device added (same type)	The same cause as in ID372, but refers to Slot D.	
	375	Device added (same type)	The same cause as in ID372, but refers to Slot E.	

Fault code	Fault ID	Fault name	Possible cause	How to correct the fault
39	382	Device removed	An option board was removed from slot A or B.	The device is not available. Reset the fault.
	383	Device removed	The same cause as in ID380, but refers to Slot C	
	384	Device removed	The same cause as in ID380, but refers to Slot D	
	385	Device removed	The same cause as in ID380, but refers to Slot E	
40	390	Device unknown	An unknown device was connected (the power unit/option board)	The device is not available. If the fault occurs again, ask instructions from your nearest distributor.
41	400	IGBT temperature	<p>The calculated IGBT temperature is too high.</p> <ul style="list-style-type: none"> <li>• too high a motor load</li> <li>• too high an ambient temperature</li> <li>• hardware malfunction</li> </ul>	<p>Do a check of the parameter settings.</p> <p>Examine the actual amount and flow of cooling air.</p> <p>Do a check of the ambient temperature.</p> <p>Examine the heatsink for dust.</p> <p>Make sure that the switching frequency is not too high in relation to the ambient temperature and the motor load.</p> <p>Do a check of the cooling fan.</p> <p>Make an identification run.</p>
44	431	Device changed (different type)	There is a new power unit of a different type. Parameters are not available in the settings.	<p>Reset the fault.</p> <p>The drive reboots after you reset the fault.</p> <p>Set the power unit parameters again.</p>
	433	Device changed (different type)	The option board in slot C was replaced by a new one that you have not used before in the same slot. No parameter settings are saved.	Reset the fault. Set the option board parameters again.
	434	Device changed (different type)	The same cause as in ID433, but refers to Slot D.	
	435	Device changed (different type)	The same cause as in ID433, but refers to Slot D.	

Fault code	Fault ID	Fault name	Possible cause	How to correct the fault
45	441	Device added (different type)	There is a new power unit of a different type. Parameters are not available in the settings.	Reset the fault. The drive reboots after you reset the fault. Set the power unit parameters again.
	443	Device added (different type)	A new option board, that you have not used before in the same slot, was put in slot C. No parameter settings are saved.	Set the option board parameters again.
	444	Device added (different type)	The same cause as in ID443, but refers to Slot D.	
	445	Device added (different type)	The same cause as in ID443, but refers to Slot E.	
46	662	Real Time Clock	The voltage of the RTC battery is low.	Replace the battery.
47	663	Software updated	The software of the drive was updated, the full software package or an application.	No steps are necessary.
50	1050	AI low fault	1 or more of the available analogue input signals is below 50% of the minimum signal range. A control cable is defective or loose. A malfunction in a signal source.	Replace the defective parts. Do a check of the analogue input circuit. Make sure that parameter AI1 Signal Range is set correctly.
51	1051	Device external fault	The digital input signal that is set with parameter P3.5.1.11 or P3.5.1.12 was activated.	This is a user-defined fault. Do a check of the digital inputs and schematics.
52	1052	Keypad communication fault	The connection between the control panel and the drive is defective.	Do a check of the control panel connection and the control panel cable if you have it.
	1352			
53	1053	Fieldbus communication fault	The data connection between the fieldbus master and the fieldbus board is defective.	Do a check of the installation and fieldbus master.

Fault code	Fault ID	Fault name	Possible cause	How to correct the fault
54	1354	Slot A fault	A defective option board or slot	Do a check of the board and the slot. Ask instructions from your nearest distributor.
	1454	Slot B fault		
	1554	Slot C fault		
	1654	Slot D fault		
	1754	Slot E fault		
57	1057	Identification	There was a failure in the identification run.	Make sure that the motor is connected to the drive. Make sure that there is no load on the motor shaft. Make sure that the start command is not removed before the identification run is complete.
58	1058	Mechanical brake	The actual status of the mechanical brake is different from the control signal for longer than the value of P3.20.6.	Do a check of the status and connections of the mechanical brake. See parameter P3.5.1.44 and parameter Group 3.20: Mechanical brake.
63	1063	Quick Stop fault	The Quick stop function is activated	Find the cause for the quick stop activation. After you find it, correct it. Reset the fault and restart the drive. See parameter P3.5.1.26 and the quick stop parameters.
	1363	Quick Stop alarm		
65	1065	PC communication fault	The data connection between the PC and the drive is defective	Do a check of the installation, cable and terminals between the PC and the drive.
66	1366	Thermistor input 1 fault	The motor temperature increased.	Do a check of the motor cooling and the load. Do a check of the thermistor connection. If the thermistor input is not used, you have to short-circuit it. Ask instructions from your nearest distributor.
	1466	Thermistor input 2 fault		
	1566	Thermistor input 3 fault		



Fault code	Fault ID	Fault name	Possible cause	How to correct the fault
68	1301	Maintenance counter 1 alarm	The value of the maintenance counter is higher than the alarm limit.	Do the necessary maintenance. Reset the counter. See parameter B3.16.4 or P3.5.1.40.
	1302	Maintenance counter 1 fault	The value of the maintenance counter is higher than the fault limit.	
	1303	Maintenance counter 2 alarm	The value of the maintenance counter is higher than the alarm limit.	
	1304	Maintenance counter 2 fault	The value of the maintenance counter is higher than the fault limit.	
69	1310	Fieldbus communication fault	The ID number that is used to map the values to Fieldbus Process Data Out is not valid.	Do a check of the parameters in the Fieldbus Data Mapping menu.
	1311		It is not possible to convert 1 or more values for Fieldbus Process Data Out.	The type of the value is undefined. Do a check of the parameters in the Fieldbus Data Mapping menu.
	1312		There is an overflow when the values for Fieldbus Process Data Out (16-bit) are mapped and converted.	Do a check of the parameters in the Fieldbus Data Mapping menu.
76	1076	Start prevented	The start command is blocked to prevent the accidental rotation of the motor during the first power-up.	Reset the drive to start the correct operation. The parameter settings tell if it is necessary to restart the drive.
77	1077	>5 connections	There are more than 5 active fieldbus or PC tool connections. You can use only 5 connections at the same time.	Leave 5 active connections. Remove the other connections.
100	1100	Soft fill timeout	There is a timeout in the Soft fill function in the PID controller. The process value was not achieved in the time limit. A pipe that broke can be the cause.	Do a check of the process. Do a check of the parameters in the menu M3.13.8.

Fault code	Fault ID	Fault name	Possible cause	How to correct the fault
101	1101	Feedback supervision fault (PID1)	The PID controller: the feedback value is not in the supervision limits (P3.13.6.2 and P3.13.6.3) and the delay (P3.13.6.4), if you set the delay.	Do a check of the process. Do a check of the parameter settings, the supervision limits and the delay.
105	1105	Feedback supervision fault (ExtPID)	The external PID controller: the feedback value is not in the supervision limits (P3.14.4.2 and P3.14.4.3) and the delay (P3.14.4.4), if you set the delay.	
109	1109	Input pressure supervision	The supervision signal of the input pressure (P3.13.9.2) is lower than the alarm limit (P3.13.9.7).	Do a check of the process. Do a check of the parameters in menu M3.13.9. Do a check of the input pressure sensor and connections.
	1409		The supervision signal of the input pressure (P3.13.9.2) is lower than the fault limit (P3.13.9.8).	
111	1315	Temperature fault 1	1 or more of the temperature input signals (set in P3.9.6.1) is higher than the alarm limit (P3.9.6.2).	Find the cause of the temperature rise. Do a check of the temperature sensor and connections. If no sensor is connected, make sure that the temperature input is hardwired. See the option board manual for more data.
	1316		1 or more of the temperature input signals (set in P3.9.6.1) is higher than the fault limit (P3.9.6.3).	
112	1317	Temperature fault 2	1 or more of the temperature input signals (set in P3.9.6.5) is higher than the fault limit (P3.9.6.6).	
	1318		1 or more of the temperature input signals (set in P3.9.6.5) is higher than the fault limit (P3.9.6.7).	
300	700	Unsupported	The application is not compatible (it is unsupported).	Replace the application.
	701		The option board or the slot is not compatible (it is unsupported).	Remove the option board.

## 11.4 TOTAL AND TRIP COUNTERS

The Vacon® AC drive has different counters based on the operation time of the drive and the energy consumption. Some of the counters measure total values and some can be reset.

The energy counters measure the energy that is taken from the supply network. The other counters are used to measure, for example, the operation time of the drive or the run time of the motor.

It is possible to monitor all the counter values from the PC, keypad or fieldbus. If you use the keypad or the PC, you can monitor the counter values in the Diagnostics menu. If you use fieldbus, you can read the counter values with the ID numbers. In this chapter, you find data on these ID numbers.

#### 11.4.1 OPERATING TIME COUNTER

It is not possible to reset the operating time counter of the control unit. The counter is in the submenu Total counters. The value of the counter has 5 different 16-bit values. To read the value of the counter through fieldbus, use these ID numbers.

- **ID 1754 Operating Time Counter (years)**
- **ID 1755 Operating Time Counter (days)**
- **ID 1756 Operating Time Counter (hours)**
- **ID 1757 Operating Time Counter (minutes)**
- **ID 1758 Operating Time Counter (seconds)**

Example: You receive the value *1a 143d 02:21* of the operating time counter from the fieldbus.

- ID1754: 1 (years)
- ID1755: 143 (days)
- ID1756: 2 (hours)
- ID1757: 21 (minutes)
- ID1758: 0 (seconds)

#### 11.4.2 OPERATING TIME TRIP COUNTER

The operating time trip counter of the control unit can be reset. It is in the submenu Trip counters. It is possible to reset the counter with the PC, the control panel, or the fieldbus. The value of the counter has 5 different 16-bit values. To read the value of the counter through fieldbus, use these ID numbers.

- **ID 1766 Operating Time Trip Counter (years)**
- **ID 1767 Operating Time Trip Counter (days)**
- **ID 1768 Operating Time Trip Counter (hours)**
- **ID 1769 Operating Time Trip Counter (minutes)**
- **ID 1770 Operating Time Trip Counter (seconds)**

Example: You receive the value *1a 143d 02:21* of the operating time trip counter from the fieldbus.

- ID1766: 1 (years)
- ID1767: 143 (days)
- ID1768: 2 (hours)
- ID1769: 21 (minutes)
- ID1770: 0 (seconds)

### ID 2311 OPERATING TIME TRIP COUNTER RESET

You can reset the operating time trip counter with the PC, the control panel, or the fieldbus. If you use the PC or the control panel, reset the counter in the Diagnostics menu.

If you use the fieldbus, to reset the counter, set a rising edge (0 => 1) to ID2311 Operating Time Trip Counter Reset.

#### 11.4.3 RUN TIME COUNTER

The run time counter of the motor cannot be reset. It is in the submenu Total counters. The value of the counter has 5 different 16-bit values. To read the value of the counter through fieldbus, use these ID numbers.

- **ID 1772 Run Time Counter (years)**
- **ID 1773 Run Time Counter (days)**
- **ID 1774 Run Time Counter (hours)**
- **ID 1775 Run Time Counter (minutes)**
- **ID 1776 Run Time Counter (seconds)**

Example: You receive the value *1a 143d 02:21* of the run time counter from the fieldbus.

- ID1772: 1 (years)
- ID1773: 143 (days)
- ID1774: 2 (hours)
- ID1775: 21 (minutes)
- ID1776: 0 (seconds)

#### 11.4.4 POWER ON TIME COUNTER

The power on time counter of the power unit is in the submenu Total counters. It is not possible to reset the counter. The value of the counter has 5 different 16-bit values. To read the value of the counter through fieldbus, use these ID numbers.

- **ID 1777 Power On Time Counter (years)**
- **ID 1778 Power On Time Counter (days)**
- **ID 1779 Power On Time Counter (hours)**
- **ID 1780 Power On Time Counter (minutes)**
- **ID 1781 Power On Time Counter (seconds)**

Example: You receive the value *1a 240d 02:18* of the power on time counter from the fieldbus.

- ID1777: 1 (years)
- ID1778: 240 (days)
- ID1779: 2 (hours)
- ID1780: 18 (minutes)
- ID1781: 0 (seconds)

#### 11.4.5 ENERGY COUNTER

The energy counter counts the total quantity of energy that the drive gets from the supply network. The counter cannot be reset. To read the value of the counter through fieldbus, use these ID numbers.

##### **ID 2291 Energy Counter**

The value has always 4 digits. The format and the unit of the counter change to agree with the energy counter value. See the example below.

Example:

- 0.001 kWh
- 0.010 kWh
- 0.100 kWh
- 1.000 kWh
- 10.00 kWh
- 100.0 kWh
- 1.000 MWh
- 10.00 MWh
- 100.0 MWh
- 1.000 GWh
- etc...

##### **ID2303 Energy Counter Format**

The energy counter format gives the position of the decimal point in the value of the Energy Counter.

- 40 = 4 digits, 0 fractional digits
- 41 = 4 digits, 1 fractional digit
- 42 = 4 digits, 2 fractional digits
- 43 = 4 digits, 3 fractional digits

Example:

- 0.001 kWh (Format = 43)
- 100.0 kWh (Format = 41)
- 10.00 MWh (Format = 42)

##### **ID2305 Energy Counter Unit**

The energy counter unit gives the unit for the value of the Energy Counter.

- 0 = kWh
- 1 = MWh
- 2 = GWh
- 3 = TWh
- 4 = PWh

Example: If you receive the value 4500 from ID2291, the value 42 from ID2303, and the value 0 from ID2305, the result is 45.00 kWh.

#### 11.4.6 ENERGY TRIP COUNTER

The energy trip counter counts the quantity of energy that the drive gets from the supply network. The counter is in the submenu Trip counters. You can reset the counter with the PC, the control panel, or the fieldbus. To read the value of the counter through fieldbus, use these ID numbers.

##### **ID 2296 Energy Trip Counter**

The value has always 4 digits. The format and the unit of the counter change to agree with the energy trip counter value. See the example below. You can monitor the energy counter format and unit with ID2307 Energy Trip Counter Format and ID2309 Energy trip Counter unit.

Example:

- 0.001 kWh
- 0.010 kWh
- 0.100 kWh
- 1.000 kWh
- 10.00 kWh
- 100.0 kWh
- 1.000 MWh
- 10.00 MWh
- 100.0 MWh
- 1.000 GWh
- etc...

##### **ID2307 Energy Trip Counter Format**

The energy trip counter format gives the position of the decimal point in the value of the Energy Trip Counter.

- 40 = 4 digits, 0 fractional digits
- 41 = 4 digits, 1 fractional digit
- 42 = 4 digits, 2 fractional digits
- 43 = 4 digits, 3 fractional digits

Example:

- 0.001 kWh (Format = 43)
- 100.0 kWh (Format = 41)
- 10.00 MWh (Format = 42)

**ID2309 Energy Trip Counter Unit**

The energy trip counter unit gives the unit for the value of the Energy Trip Counter.

- 0 = kWh
- 1 = MWh
- 2 = GWh
- 3 = TWh
- 4 = PWh

**ID2312 Energy Trip Counter Reset**

To reset the energy trip counter, use the PC, the control panel, or the fieldbus. If you use the PC or the control panel, reset the counter in the Diagnostics menu. If you use the fieldbus, set a rising edge to ID2312 Energy Trip Counter Reset.

## 12 APPENDIX 1

### 12.1 THE DEFAULT VALUES OF PARAMETERS IN THE DIFFERENT APPLICATIONS

#### The explanation of symbols in the table

- A = Standard application
- B = Local/ Remote application
- C = Multi-step speed application
- D = PID control application
- E = Multi-purpose application
- F = Motor potentiometer application



**Table 124: The default values of parameters in the different applications**

Index	Parameter	Default						Unit	ID	Description
		A	B	C	D	E	F			
3.2.1	Rem Control Place	0	0	0	0	0	0		172	0 = I/O Control
3.2.2	Local/Remote	0	0	0	0	0	0		211	0 = Remote
3.2.6	I/O A Logic	2	2	2	2	2	2		300	2 = Forw-Back (edge)
3.2.7	I/O B Logic	2	2	2	2	2	2		363	2 = Forw-Back (edge)
3.3.1.5	I/O A Ref Sel	6	5	6	7	6	8		117	5 = AI2 6 = AI1 + AI2 7 = PID 8 = Motor Potentiometer
3.3.1.6	I/O B Ref Sel	4	4	4	4	4	4		131	4 = AI1
3.3.1.7	Keypad Ref Sel	2	2	2	2	2	2		121	2 = Keypad Reference
3.3.1.10	Fieldbus Ref Sel	3	3	3	3	3	3		122	3 = Fieldbus Reference
3.3.2.1	Torque Ref Sel	0	0	0	0	4	0		641	0 = Not Used 4 = AI2
3.3.3.1	Preset Freq Mode	-	-	0	0	0	0		182	0 = Binary Coded
3.3.3.3	Preset Freq 1	-	-	10.0	10.0	5.0	10.0		105	
3.3.3.4	Preset Freq 2	-	-	15.0	-	-	-	Hz	106	
3.3.3.5	Preset Freq 3	-	-	20.0	-	-	-	Hz	126	
3.3.3.6	Preset Freq 4	-	-	25.0	-	-	-	Hz	127	
3.3.3.7	Preset Freq 5	-	-	30.0	-	-	-	Hz	128	
3.3.3.8	Preset Freq 6	-	-	40.0	-	-	-	Hz	129	
3.3.3.9	Preset Freq 7	-	-	50.0	-	-	-	Hz	130	
3.5.1.1	Ctrl Signal 1 A	100	100	100	100	100	100		403	100 = DigIN SlotA.1

**Table 124: The default values of parameters in the different applications**

Index	Parameter	Default						Unit	ID	Description
		A	B	C	D	E	F			
3.5.1.2	Ctrl Signal 2 A	101	101	101	0	101	101		404	0 = DigIN Slot0.1 101 = DigIN SlotA.2
3.5.1.4	Ctrl Signal 1 B	0	103	0	103	0	0		423	0 = DigIN Slot0.1 103 = DigIN SlotA.4
3.5.1.5	Ctrl Signal 2 B	-	104	-	-	-	-		424	104 = DigIN SlotA.5
3.5.1.7	I/O B Ctrl Force	0	105	0	105	0	0		425	0 = DigIN Slot0.1 105 = DigIN SlotA.6
3.5.1.8	I/O B Ref Force	0	105	0	105	0	0		343	0 = DigIN Slot0.1 105 = DigIN SlotA.6
3.5.1.9	Fieldbus Ctrl Force	0	0	0	0	0	0		411	0 = DigIN Slot0.1
3.5.1.10	Keypad Ctrl Force	0	0	0	0	0	0		410	0 = DigIN Slot0.1
3.5.1.11	External Fault Close	102	102	102	101	104	102		405	101 = DigIN SlotA.2 102 = DigIN SlotA.3 104 = DigIN SlotA.5
3.5.1.13	Fault Reset Close	105	0	0	102	102	0		414	0 = DigIN Slot0.1 102 = DigIN SlotA.3 105 = DigIN SlotA.6
3.5.1.19	Ramp 2 Selection	0	0	0	0	105	0		408	0 = DigIN Slot0.1 105 = DigIN SlotA.6
3.5.1.21	Preset Freq Sel0	103	0	103	104	103	103		419	0 = DigIN Slot0.1 103 = DigIN SlotA.4 104 = DigIN SlotA.5
3.5.1.22	Preset Freq Sel1	104	0	104	0	0	0		420	0 = DigIN Slot0.1 104 = DigIN SlotA.5

**Table 124: The default values of parameters in the different applications**

Index	Parameter	Default						Unit	ID	Description
		A	B	C	D	E	F			
3.5.1.23	Preset Freq Sel2	0	0	105	0	0	0		421	0 = DigIN Slot0.1 105 = DigIN SlotA.6
3.5.1.24	MotPot UP	0	0	0	0	0	104		418	0 = DigIN Slot0.1 104 = DigIN SlotA.5
3.5.1.25	MotPot DOWN	0	0	0	0	0	105		417	0 = DigIN Slot0.1 105 = DigIN SlotA.6
3.5.2.1.1	AI1 Signal Selection	100	100	100	100	100	100		377	100 = AnIN SlotA.1
3.5.2.1.2	AI1 Filter Time	0.1	0.1	0.1	0.1	0.1	0.1	s	378	
3.5.2.1.3	AI1 Signal Range	0	0	0	0	0	0		379	0 = 0..10V / 0..20mA
3.5.2.1.4	AI1 Custom Min	0.0	0.0	0.0	0.0	0.0	0.0	%	380	
3.5.2.1.5	AI1 Custom Max	100.0	100.0	100.0	100.0	100.0	100.0	%	381	
3.5.2.1.6	AI1 Signal Inversion	0	0	0	0	0	0		387	0 = Normal
3.5.2.2.1	AI2 Signal Selection	101	101	101	101	101	101		388	101 = AnIN SlotA.2
3.5.2.2.2	AI2 Filter Time	0.1	0.1	0.1	0.1	0.1	0.1	s	389	
3.5.2.2.3	AI2 Signal Range	1	1	1	1	1	1		390	1 = 2..10V / 4..20mA
3.5.2.2.4	AI2 Custom Min	0.0	0.0	0.0	0.0	0.0	0.0	%	391	
3.5.2.2.5	AI2 Custom Max	100.0	100.0	100.0	100.0	100.0	100.0	%	392	
3.5.2.2.6	AI2 Signal Inversion	0	0	0	0	0	0		398	0 = Normal
3.5.3.2.1	RO1 Function	2	2	2	2	2	2		11001	2 = Run
3.5.3.2.4	RO2 Function	3	3	3	3	3	3		11004	3 = Fault
3.5.3.2.7	RO3 Function	1	1	1	1	1	1		11007	1 = Ready

**Table 124: The default values of parameters in the different applications**

Index	Parameter	Default						Unit	ID	Description
		A	B	C	D	E	F			
3.5.4.1.1	A01 Function	2	2	2	2	2	2		10050	2 = Output Freq
3.5.4.1.2	A01 Filter Time	1.0	1.0	1.0	1.0	1.0	1.0	s	10051	
3.5.4.1.3	A01 Min Signal	0	0	0	0	0	0		10052	
3.5.4.1.4	A01 Min Scale	0.0	0.0	0.0	0.0	0.0	0.0		10053	
3.5.1.1.5	A01 Max Scale	0.0	0.0	0.0	0.0	0.0	0.0		10054	
3.13.2.6	SP1 Source	-	-	-	3	-	-		332	3 = AI1
3.13.3.1	Function	-	-	-	1	-	-		333	1 = Source 1
3.13.3.3	FB 1 Source	-	-	-	2	-	-		334	2 = AI2



# VACON®

[www.danfoss.com](http://www.danfoss.com)

Vacon Ltd  
Member of the Danfoss Group  
Runsorintie 7  
65380 Vaasa  
Finland

Document ID:



Rev. G

Sales code: DOC-APP100+DLUK