

VACON[®] 100
AC DRIVES

**INTEGRATED BACNET
INSTALLATION MANUAL**

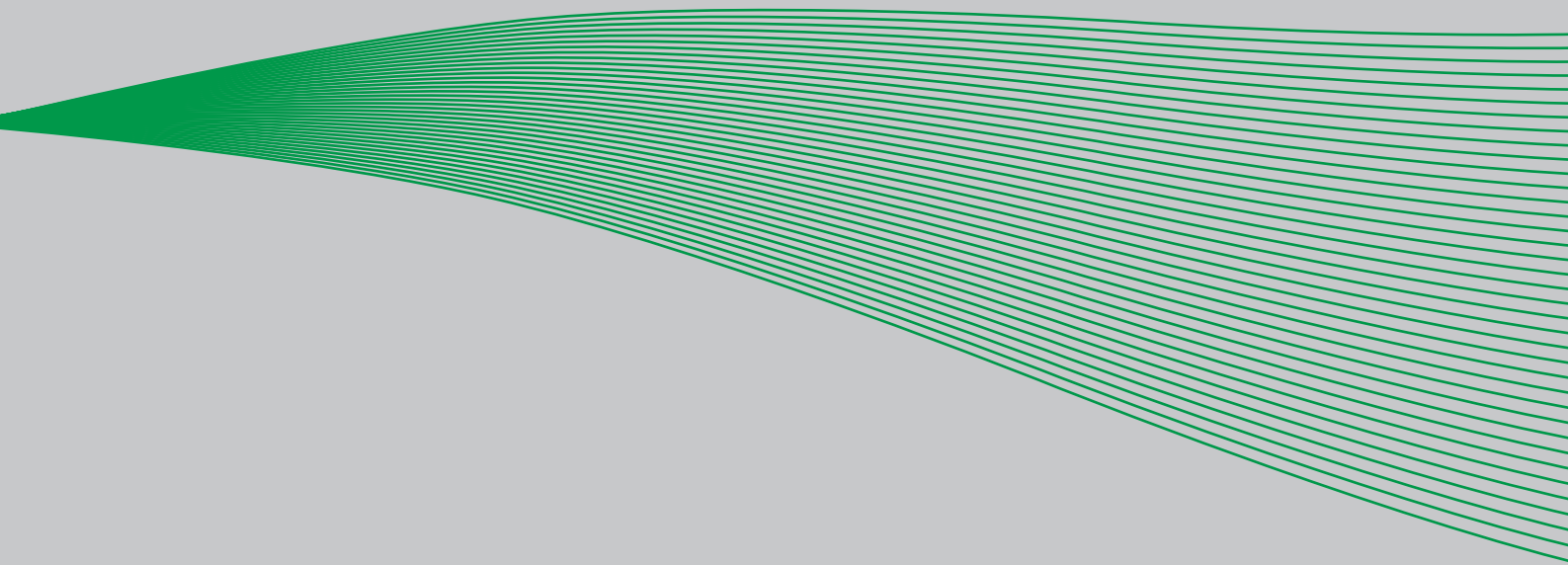

TABLE OF CONTENTS

Document: DPD00091C
Version release date: 17.2.15

1. Safety	2
1.1 Danger.....	2
1.2 Warnings.....	3
1.3 Earthing and earth fault protection.....	4
2. BACnet - general info	5
3. BACnet technical data	6
3.1 BACnet MS/TP protocol.....	6
3.2 BACnet IP protocol.....	6
4. Programming	7
4.1 BACnet MS/TP parameters and monitoring values.....	7
4.2 BACnet IP parameters and monitoring values.....	8
4.2.1 Ethernet common settings.....	8
4.2.2 BACnet IP settings.....	9
4.3 BACnet MS/TP parameter descriptions.....	11
4.3.1 BACnet MS/TP Parameters.....	11
4.3.2 BACnet MS/TP monitoring values.....	12
4.4 BACnet IP parameter descriptions.....	13
4.4.1 Ethernet common settings.....	13
4.4.2 BACnet IP settings.....	14
4.4.3 BACnet IP monitoring values.....	15
5. Installation	16
5.1 Vacon® 100.....	16
5.1.1 Prepare for use through Ethernet.....	17
5.1.2 Prepare for use through RS485.....	20
5.2 Installation in Vacon® 100 X.....	24
5.2.1 Prepare for use through Ethernet.....	24
5.2.2 Prepare for use through RS485.....	25
6. Communications	27
6.1 Object types and properties supported.....	27
6.1.1 Binary Value Object.....	28
6.1.2 Analogue Value Object.....	29
6.2 Control word bits.....	31
6.3 Status word bits.....	31
7. Fault tracing	32
7.1 Typical fault conditions.....	32
7.2 Other fault conditions.....	33
8. Quick setup	35
9. Annex - Protocol implementation conformance statement	36



1. SAFETY

This manual contains clearly marked cautions and warnings that are intended for your personal safety and to avoid any unintentional damage to the product or connected appliances.

Please read the information included in cautions and warnings carefully.

The cautions and warnings are marked as follows:

Table 1. Warning signs

	= DANGER! Dangerous voltage
	= WARNING or CAUTION
	= Caution! Hot surface

1.1 DANGER



The **components of the power unit are live** when the drive is connected to mains potential. Coming into contact with this voltage is **extremely dangerous** and may cause death or severe injury.



The **motor terminals U, V, W and the brake resistor terminals are live** when the AC drive is connected to mains, even if the motor is not running.



After disconnecting the AC drive from the mains, **wait** until the indicators on the keypad go out (if no keypad is attached, see the indicators on the cover). Wait 5 more minutes before doing any work on the connections of the drive. Do not open the cover before this time has expired. After expiration of this time, use a measuring equipment to absolutely ensure that no voltage is present. **Always ensure absence of voltage before starting any electrical work!**



The control I/O-terminals are isolated from the mains potential. However, the **relay outputs and other I/O-terminals may have a dangerous control voltage** present even when the AC drive is disconnected from mains.



Before connecting the AC drive to mains make sure that the front and cable covers of the drive are closed.



During a ramp stop (see the Application Manual), the motor is still generating voltage to the drive. Therefore, do not touch the components of the AC drive before the motor has completely stopped. Wait until the indicators on the keypad go out (if no keypad is attached, see the indicators on the cover). Wait additional 5 minutes before starting any work on the drive.

1.2 WARNINGS



The AC drive is meant for **fixed installations only**.



Do not perform any measurements when the AC drive is connected to the mains.



The **earth leakage current** of the AC drives exceeds 3.5mA AC. According to standard EN61800-5-1, a **reinforced protective ground connection** must be ensured. See Chapter 1.3.



If the AC drive is used as a part of a machine, the **machine manufacturer is responsible** for providing the machine with a **supply disconnecting device** (EN 60204-1).



Only **spare parts** delivered by Vacon can be used.



At power-up, power brake or fault reset **the motor will start immediately** if the start signal is active, unless the pulse control for Start/Stop logic has been selected. Furthermore, the I/O functionalities (including start inputs) may change if parameters, applications or software are changed. Disconnect, therefore, the motor if an unexpected start can cause danger.



The **motor starts automatically** after automatic fault reset if the auto restart function is activated. See the Application Manual for more detailed information.



Prior to measurements on the motor or the motor cable, disconnect the motor cable from the AC drive.



Do not touch the components on the circuit boards. Static voltage discharge may damage the components.



Check that the **EMC level** of the AC drive corresponds to the requirements of your supply network.



Wear protective gloves when you do mounting, cabling or maintenance operations. There can be sharp edges in the AC drive that can cause cuts.

1.3 EARTHING AND EARTH FAULT PROTECTION



CAUTION!

The AC drive must always be earthed with an earthing conductor connected to the earthing terminal marked with

The earth leakage current of the drive exceeds 3.5mA AC. According to EN61800-5-1, one or more of the following conditions for the associated protective circuit must be satisfied:

- a) The protective conductor must have a cross-sectional area of at least 10 mm² Cu or 16 mm² Al, through its total run.
- b) Where the protective conductor has a cross-sectional area of less than 10 mm² Cu or 16 mm² Al, a second protective conductor of at least the same cross-sectional area must be provided up to a point where the protective conductor has a cross-sectional area not less than 10 mm² Cu or 16 mm² Al.
- c) Automatic disconnection of the supply in case of loss of continuity of the protective conductor.

The cross-sectional area of every protective earthing conductor which does not form part of the supply cable or cable enclosure must, in any case, be not less than:

- 2.5mm² if mechanical protection is provided or
- 4mm² if mechanical protection is not provided.

The earth fault protection inside the AC drive protects only the drive itself against earth faults in the motor or the motor cable. It is not intended for personal safety.

Due to the high capacitive currents present in the AC drive, fault current protective switches may not function properly.



Do not perform any voltage withstand tests on any part of the AC drive. There is a certain procedure according to which the tests must be performed. Ignoring this procedure may result in damaged product.

NOTE! You can download the English and French product manuals with applicable safety, warning and caution information from www.vacon.com/downloads.

REMARQUE Vous pouvez télécharger les versions anglaise et française des manuels produit contenant l'ensemble des informations de sécurité, avertissements et mises en garde applicables sur le site www.vacon.com/downloads.

2. BACNET - GENERAL INFO

BACnet stands for 'Building Automation and Control Networks'. It is the common name for the communication standard ISO 16484-5 which defines the methods and the protocol for cooperating building automation devices to communicate. Devices can be designed to operate using BACnet communication protocol as well as utilising BACnet protocol to communicate between systems. BACnet is an internationally accepted protocol for building automation (e.g. lighting control, air conditioning and heating automation) and control over a communications network.

BACnet provides a method by which computer-based control equipment, from different manufacturers can work together, or 'interoperate'. For this to be achieved, components must be able to exchange and understand BACnet data messages.

Your Vacon[®] 100 drive is equipped with BACnet support as standard.

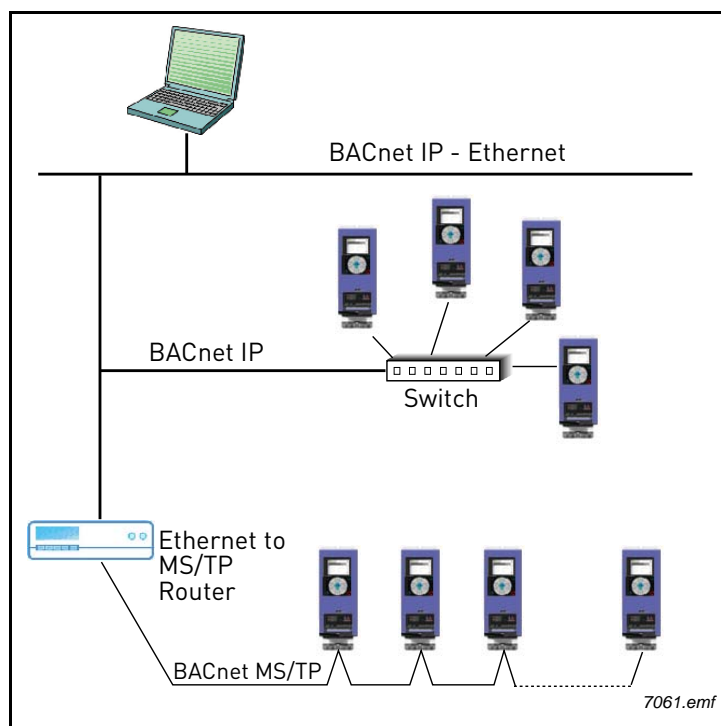

Figure 1. Principal example diagram of BACnet

If you have problems related to BACnet, contact tech.supportVDF@vacon.com. Send a description of the problem and the drive's *Service Information* file. You can download the Service Information file with the Vacon Live tool. In BACnet/IP networks, also send a log file captured with the Wireshark tool that contains the error situation.

3. BACNET TECHNICAL DATA

3.1 BACNET MS/TP PROTOCOL

Table 2.

Connections and communications	Interface	RS-485
	Data transfer method	RS-485 MS/TP, half-duplex
	Transfer cable	STP (Shielded Twisted Pair), type Belden 9841 or similar
	Connector	2.5 mm ²
	Electrical isolation	Functional
	BACnet MS/TP	As described in ANSI/ASHRAE Standards 135-2010 Ver.1 Rev.12
	Baud rate	9600, 19200, 38400 and 76800 baud(supports autobaud detection)

3.2 BACNET IP PROTOCOL

Table 3.

Connections and communications	Interface	100BaseTX, IEEE 802.3 compatible
	Data transfer method	Ethernet half/full -duplex
	Data transfer speed	10/100 MBit/s, autosensing
	Protocol	BACnet over UDP/IP
	Connector	Shielded RJ45 connector.
	Cable type	CAT5e STP
	BACnet IP	As described in ANSI/ASHRAE Standards 135-2010 Ver.1 Rev.12
	IP address mode	Selectable: Static or DHCP

4. PROGRAMMING

You will find basic information on how to use the control keypad in the Application Manual of your Vacon® 100 drive.

Below you will find some examples of navigation paths to the fieldbus parameters.

Table 4.

1. First ensure that the right fieldbus protocol is selected.
<p>Activating BACnet MSTP (P5.8.1.1) Main Menu > I/O and Hardware > RS-485 > Common settings > Protocol > BACnet MSTP <</p> <p>Activating BACnet IP (P5.9.3.1.4) Main Menu > I/O and Hardware > Ethernet > Bacnet IP > Protocol in use > Yes <</p>
2. Select 'Fieldbus control' as the Remote Control Place.
<p>Control Place (P3.2.1) Main Menu > Parameters > Start/Stop Setup > Rem Control Place > FieldbusCTRL <</p>
3. Activate Remote control.
<p>Local/Remote (P3.2.2) Main Menu > Parameters > Start/Stop Setup > Local/Remote > Remote <</p>
4. Set up Protocol Parameters.
<p>BACnet MS/TP parameters see Chapter 4.1 BACnet IP parameters see Chapter 4.2</p>

4.1 BACNET MS/TP PARAMETERS AND MONITORING VALUES

Table 5. Parameters related with BACnet used through MS/TP

Code	Parameter	Min	Max	Default	ID	Description
P5.8.3.1.1	Baud rate	9600	76800	9600	2392	Communication speed 1 = 9600 2 = 19200 3 = 38400 4 = 76800 5 = Autobaud
P5.8.3.1.2	MAC Address	1	127	1	2331	BACnet device MAC address
P5.8.3.1.3	Instance number	0	4194304	automatic	2332	Device Object's instance number. 0 = Automatically generated from the last 22 bit from Ethernet MAC address.
P5.8.3.1.4	MaxMaster	1	127	127	2561	Max Master parameter of device object. This can be used to reduce poll for master cycles.
P5.8.3.1.5	Communication time-out	0	65535	10	2333	Defines the number of seconds after which a communication timeout is indicated after a communication break. Value 0 disables this feature.

Table 5. Parameters related with BACnet used through MS/TP

P5.8.3.1.6	MaxAPDUcycle	0	65535	0	2554	Defines the number of seconds after which the next application level message is shown after a communication break. Value 0 disables this feature.
------------	--------------	---	-------	---	------	---

Table 6. Monitoring values

Code	Parameter	Min	Max	ID	Description
P5.8.3.2.1	Fieldbus protocol status	INITIALIZING	INACTIVE	2393	See Table 12
P5.8.3.2.2	Communication status	0.0	99.999	2394	Counter for failed and good messages failed msg's <-> good msg's
P5.8.3.2.3	Actual instance	0	4194304	2395	Actual instance in use. If the instance parameter is 0, the generated instance number shows here.
P5.8.3.2.4	Last fault	See fault codes (table Table 11)		2396	Information about the latest fault detected.
P5.8.3.2.5	UartDBG	0.0.0	32767. 32767. 32767	2559	Uart error counters in the following order: framing errors. overrun errors. parity errors.
P5.8.3.2.6	ActiveCOVcount	0	20	2558	Number of active COV subscriptions

4.2 BACNET IP PARAMETERS AND MONITORING VALUES

4.2.1 ETHERNET COMMON SETTINGS

Table 7. Common settings for Ethernet Interface

Code	Parameter	Min	Max	Unit	Default	ID	Description
P5.9.1.1	IP address mode	0	1		1	2482	0 = Fixed IP 1 = DHCP with AutoIP

Table 8. Fixed IP

Code	Parameter	Min	Max	Unit	Default	ID	Description
P5.9.1.2.1	IP address				192.168.0.10	2529	The parameter is in use if P5.9.1.1 = 0/Fixed IP
P5.9.1.2.2	Subnet mask				255.255.0.0	2530	The parameter is in use if P5.9.1.1 = 0/Fixed IP
P5.9.1.2.3	Default gateway				192.168.0.1	2531	The parameter is in use if P5.9.1.1 = 0/Fixed IP
P5.9.1.3	IP address				0	2483	IP address in use
P5.9.1.4	Subnet mask				0	2484	Subnet mask in use
P5.9.1.5	Default gateway				0	2485	Default gateway in use
P5.9.1.6	MAC address					2486	MAC address

4.2.2 BACNET IP SETTINGS

Table 9. Parameters related with BACnet used through Ethernet

Code	Parameter	Min	Max	Default	ID	Description
P5.9.3.1.1	Instance number	0	4194304	automatic	2406	Device Object's instance 0 = Automatically generated from the last 22 bit from the Ethernet MAC address.
P5.9.3.1.2	BACnet Port Number	47808	47823	47808	2538	UDP port for BACnet IP communication.
P5.9.3.1.2	Communication time-out	0	65535	10	2407	Defines the number of seconds after which a communication timeout is indicated after a communication break. Value 0 disables this feature.
P5.9.3.1.3	Protocol in use	0	1	0	2408	Activates BACnet IP protocol
P5.9.3.1.4	ForeignDevice	Sub menu for Foreign Device setting				
P5.9.3.1.5.1	ForeignDevice	No	Yes	No	2555	Activates foreign device registration
P5.9.3.1.5.2	BBMD IP			192.168.0.1	2409	IP address of BBMD device to send registration
P5.9.3.1.5.3	BBMD Port	47808	47823	47808	2410	BBMD port number
P5.9.3.1.5.4	RegistrationInterval	1	65535	10	2411	Registration interval to keep a live connection to BBMD. NOTE! Registration message TTL is twice as long as this time.

Table 10. Monitoring values

Code	Parameter	Min	Max	ID	Description
P5.9.3.2.1	Fieldbus protocol status	INITIALIZING	INACTIVE	2412	See Table 12
P5.9.3.2.2	Communication status	0.0	99.999	2413	Counter for failed and good messages failed msg's <-> good msg's
P5.9.3.2.3	Actual instance	0	4194304	2414	Actual instance is use. In case instance parameter is zero you can see here generated instance number
P5.9.3.2.4	Last fault	See fault codes (Table 11)		2556	The fault code of the latest fault detected.
P5.9.3.2.5	ActiveCOVcount	0	20	2557	Number of active COV subscriptions

Table 11. Fault Code values

Fault Number	Fault Text	Description
0	No fault	No fault detected since the last power-up.
1	Connection timeout	Timeout occurred in communication.
2	MAC address	Duplicate MAC address detected.
3	Autobaud Error	Error during baudrate detection.
4	Ethernet link lost	Ethernet cable disconnected during communication.

Table 12. Fieldbus Protocol Status

Value	Text	Description
1	INITIALIZING	Protocol is starting
2	STOPPED	Protocol is stopped
3	OPERATIONAL	Communicating
4	FAULTED	Timeout/APDU time expired
5	INACTIVE	No communication

4.3 BACNET MS/TP PARAMETER DESCRIPTIONS

4.3.1 BACNET MS/TP PARAMETERS

P5.8.3.1.1 BAUD RATE

Select the communication speed for the network. The default value is 9600 baud. If Autobauding is selected, the node will detect the baudrate. There must be at least one device in the bus to select the baud rate and to start token transmitting. When the baudrate is detected, it is saved into this parameter.

NOTE! Autobauding is disabled after baudrate is detected.

P5.8.3.1.2 MAC ADDRESS

The parameters of every device must be set before connecting to the bus. Especially the parameters *MAC address* and *Baud rate* must be the same as in the master's configuration.

The first parameter, BACnet MAC (Medium Access Control) address, must be unique on the network to which it is connected. The same MAC address may be used on a device on another network within the internetwork.

Addresses 128-254 are reserved for slaves. Addresses 1-127 are valid for both masters and slaves. The portion of the address space that is actually used for masters in a particular installation is determined by the value of the Max_Master property of the Device object.

It is recommended that MAC address 0 be reserved for use by the MS/TP router. 255 is reserved for broadcasts.

P5.8.3.1.3 INSTANCE NUMBER

The Device Object's Instance number must be unique across the entire BACnet internetwork because it is used to uniquely identify the BACnet devices. It may be used to conveniently identify the BACnet device from other devices during installation.

If 0 (default) is selected, the Device Instance number is generated from the last 22 bit of the Ethernet MAC address. This unique number is then shown in the Monitor menu (actual instance).

P5.8.3.1.4 MAXMASTER

This parameter defines the last possible master on the network segment. Each master node is responsible for searching new devices from network using the 'poll for master' messages. The nodes are searched up to MAC address defined by MaxMaster parameter.

This parameter affects the cycle time of the token. We recommend to use the highest MAC address value in the network for this parameter.

P5.8.3.1.5 COMMUNICATION TIMEOUT

The BACnet MS/TP indicates timeout error if the node is not receiving a token within time defined by this parameter. It can be used to detect communication loss to other nodes. Time unit is seconds.

NOTE! Application parameter P3.9.1.6 (ID 733) can be use to define action for communication timeout.

P5.8.3.1.6 MAXAPDUcycle

This parameter defines the maximum time in seconds between APDU messages addressed to this node. The APDU messages are Application layer messages, for example, 'ReadParameter' and 'Write Parameter' messages. This can be used to detect communication loss to the controlling node.

NOTE! The application parameter P3.9.1.6 (ID 733) can be used to define the action for communication timeout.

4.3.2 BACNET MS/TP MONITORING VALUES

P5.8.3.2.1 FIELDBUS PROTOCOL STATUS

Fieldbus Protocol Status tells the status of the protocol.

P5.8.3.2.2 COMMUNICATION STATUS

The *Communication status* shows how many error and how many good messages the AC drive has received. The Communication status includes a common error counter that counts CRC and parity errors and a counter for good messages.

Only messages to the current slave in use are counted in the good messages, not MS/TP token packages.

Table 13.

Good messages	
0...999	Number of messages received without errors
Bad Frames	
0...99	Number of messages received with errors

P5.8.3.2.3 ACTUAL INSTANCE NUMBER

Shows the actual instance number.

P5.8.3.2.4 LAST FAULT

This monitor value consist of text string that gives extra information about the fault condition. Can be used to track the reason for communication timeout. See Table 11.

P5.8.3.2.5 UARTDBG

This is advanced debug information from RS-485 uart module. It shows parity, framing and overrun errors occurred while receiving the MSTP messages.

P5.8.3.2.6 ACTIVECOVcount

This shows the number of active COV subscriptions on the device.

4.4 BACNET IP PARAMETER DESCRIPTIONS

4.4.1 ETHERNET COMMON SETTINGS

P5.9.1.1 IP ADDRESS MODE

Selectable alternatives are *DHCP* (Dynamic Host Configuration Protocol) and *Fixed*.

DHCP protocol gives IP addresses to new devices connecting to local network. This address is valid for a certain period of time.

A fixed IP address is specified manually and it does not change.

If the fixed IP mode is selected, the addresses defined in the 'Fixed IP' menu come into use. The default Fixed IP is shown below.

IP: 192.168.0.10

Subnet mask: 255.255.0.0

Default gateway: 0.0.0.0

P5.9.1.3 IP ADDRESS

An *IP address* is a series of numbers (like above) specific to the device connected to the Internet.

P5.9.1.4 SUBNET MASK

The network mask marks all the bits of an IP address for the identification of the network and the subnetwork.

P5.9.1.5 DEFAULT GATEWAY

Gateway address is the IP address of a network point that acts as an entrance to another network. This needs to be defined if the device communicates with nodes on different networks, for example, if the 'Foreign Device' functionality is active.

P5.9.1.6 MAC ADDRESS

The Ethernet MAC address of the control board.

MAC address (Media Access Control) is a unique address given to each network host.

4.4.2 BACNET IP SETTINGS

P5.9.3.1.1 INSTANCE NUMBER

Similar to BACnet MS/TP device object instance number (see Chapter 4.3.1).

P5.9.3.1.2 BACNET PORT NUMBER

The UDP port for the BACnet IP communication.

P5.9.3.1.3 COMMUNICATION TIME-OUT

Defines the number of seconds after a timeout is indicated after a communication break or disconnected ethernet link. Value 0 disables communication and link supervision.

NOTE! The Application parameter P3.9.1.6 (ID 733) can be used to define the action for communication timeout.

P5.9.3.1.4 PROTOCOL IN USE

BACnet/IP protocol can be enabled and disabled with this parameter. When the parameter value is set to "1" the BACnet/IP protocol is enabled and disabled when set to "0".

P5.9.3.1.5 FOREIGNDEVICE

The foreign device settings are located under this submenu. The foreign device feature is used when the device is located in a different network than the BBMD. A normal router does not send broadcast messages between different networks. The 'Foreign device' feature solves this problem by establishing a connection to the BBMD with unicast messages. All broadcast messages are forwarded to a BBMD device that takes care of receiving and transmitting broadcast messages in both directions for all foreign devices.

P5.9.3.1.5.1 FOREIGNDEVICE

If this parameter is set to value 'Yes', the foreign device registration becomes active.

P5.9.3.1.5.2 BBMD IP

The IP address of the BACnet IP Broadcast Management Device.

P5.9.3.1.5.3 BBMD PORT

The BBMD Port number.

P5.9.3.1.5.4 REGISTRATIONINTERVAL

The registration interval to keep a live connection to the BBMD. Unit is seconds.

NOTE! The Registration TTL is twice as long as this time.

4.4.3 BACNET IP MONITORING VALUES

P5.9.3.2.1 *FIELDBUS PROTOCOL STATUS*

Fieldbus Protocol Status tells the status of the protocol.

P5.9.3.2.2 *COMMUNICATION STATUS*

The Communication status shows how many error and how many good messages the AC drive has received. The Communication status includes a common error counter that counts CRC and parity errors and a counter for good messages.

Table 14.

Good messages	
0...999	Number of messages received without errors
Bad Frames	
0...99	Number of messages received with errors

P5.9.3.2.3 *ACTUAL INSTANCE NUMBER*

The Device Object's actual instance number. This monitoring value is needed when value 0 is written to parameter P5.8.3.1.1.

P5.9.3.2.4 *LAST FAULT*

This monitor value contains a text string that gives extra information about the fault condition. Can be used to track reason for communication timeout. See Table 11.

P5.9.3.2.5 *ACTIVECOVCOUNT*

This shows the number of active COV subscriptions on the device.

5. INSTALLATION

5.1 VACON® 100

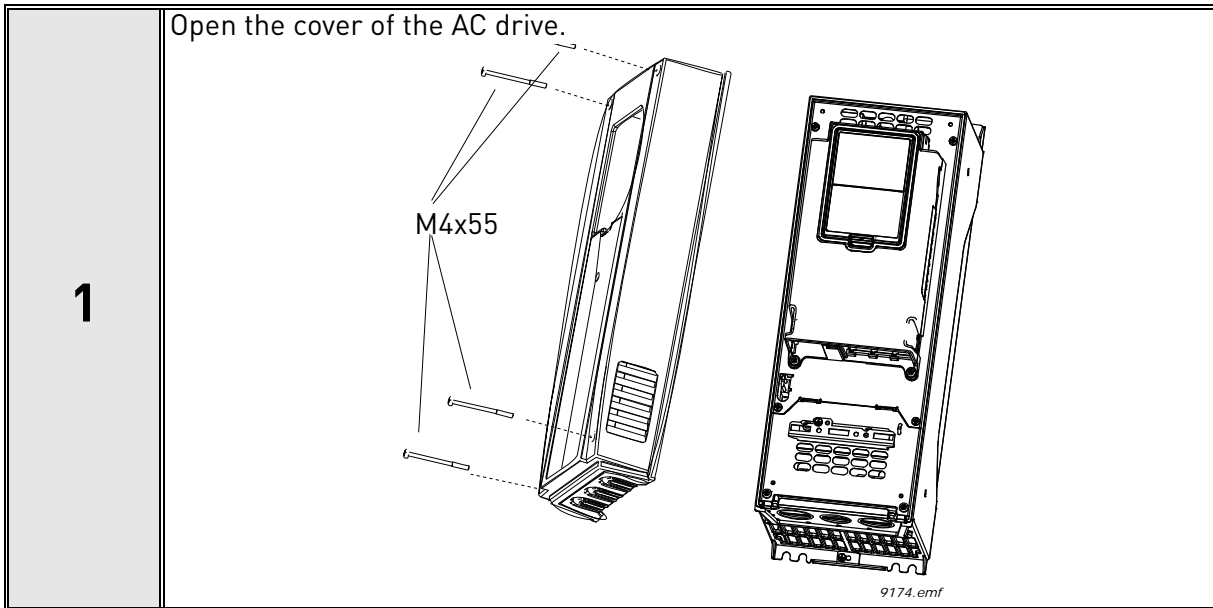

The relay outputs and other I/O-terminals may have a dangerous control voltage present even when the AC drive is disconnected from mains.

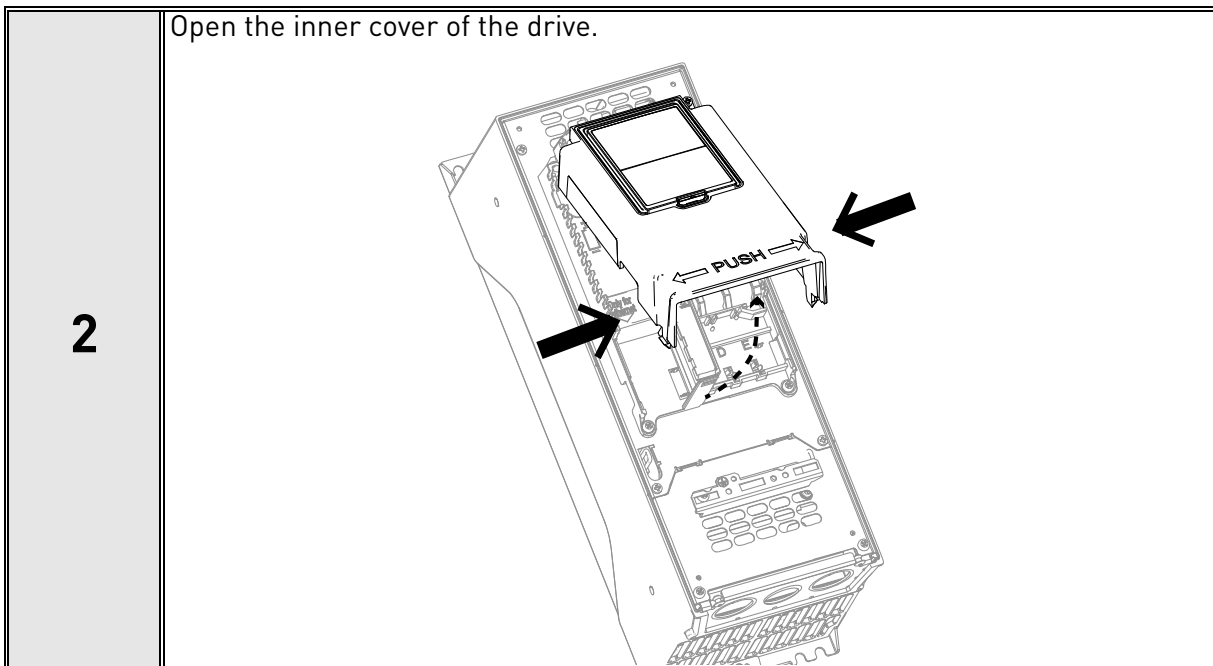

5.1.1 PREPARE FOR USE THROUGH ETHERNET

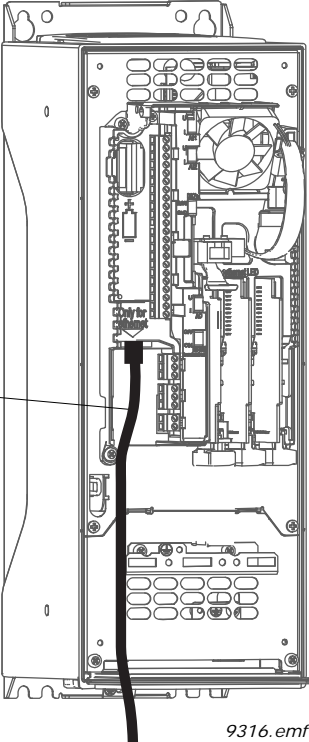
3	<p>Connect the Ethernet cable (see specification in Chapter 3.2) to its terminal as shown in figure below.</p> <div style="text-align: center;">  <p style="margin-left: 100px;">Ethernet cable</p> <p style="text-align: right; margin-right: 50px;"><i>9316.emf</i></p> </div>
---	---

4

Protection class IP21: Cut free the opening on the AC drive cover for the Ethernet cable.

Protection class IP54: Cut the rubber grommets open to slide the cables through. Should the grommets fold in while inserting the cable, just draw the cable back a bit to straighten the grommets up. Do not cut the grommet openings wider than what is necessary for the cables you are using.

NOTE! To meet the requirements of the enclosure class IP54, the connection between the grommet and the cable must be tight. Therefore, lead the first bit of the cable out of the grommet **straight** before letting it bend. If this is not possible, the tightness of the connection must be ensured with insulation tape or a cable tie.

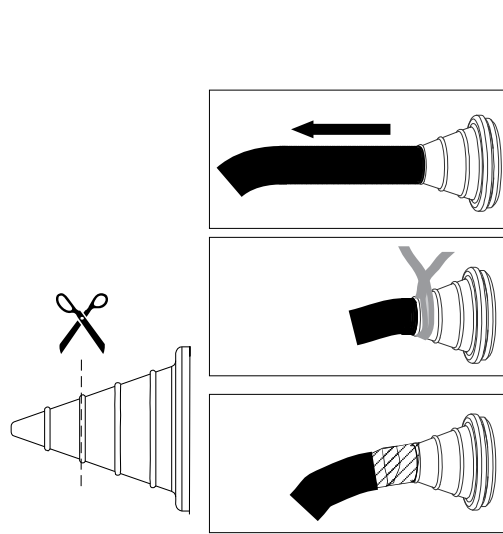
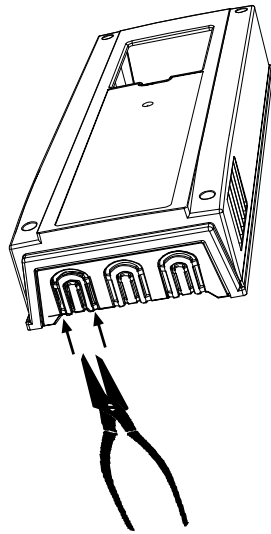

9068.emf

5

Remount the AC drive cover.

NOTE! When planning the cable runs, remember to keep the distance between the Ethernet cable and the motor cable at a **minimum of 30 cm.**

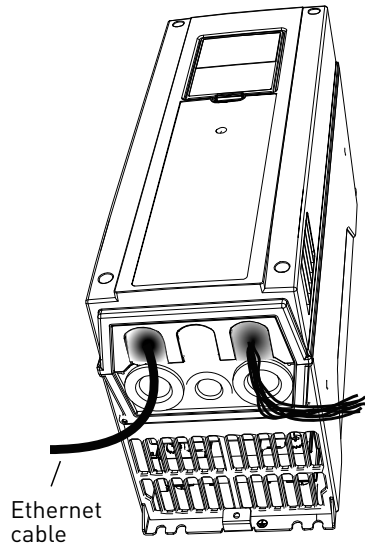

IP21

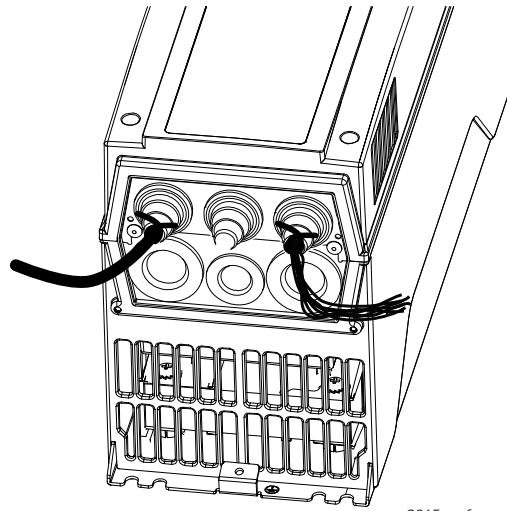

IP54

9265.emf

5.1.2 PREPARE FOR USE THROUGH RS485

1

Strip about 15 mm of the RS485 cable (see specification in Chapter 3.1) and cut off the grey cable shield. Remember to do this for both bus cables (except for the last device).

Leave no more than 10 mm of the cable outside the terminal block and strip the cables at about 5 mm to fit in the terminals. See picture below.

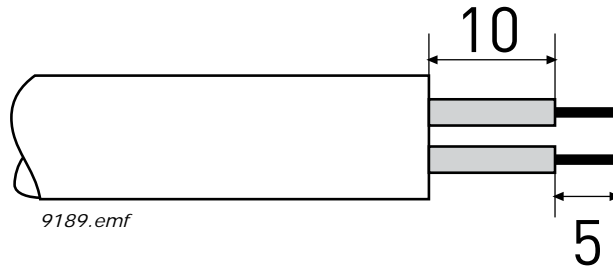

Also strip the cable now at such a distance from the terminal that you can fix it to the frame with the grounding clamp. Strip the cable at a maximum length of 15 mm. **Do not strip the aluminum cable shield!**

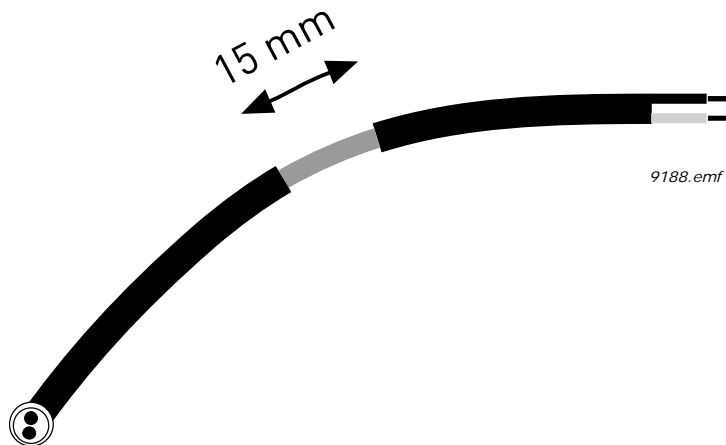

2

Then connect the cable to its appropriate terminals on Vacon 100 drive standard terminal block, terminals **A and B** (A = negative, B = positive). See figure below.

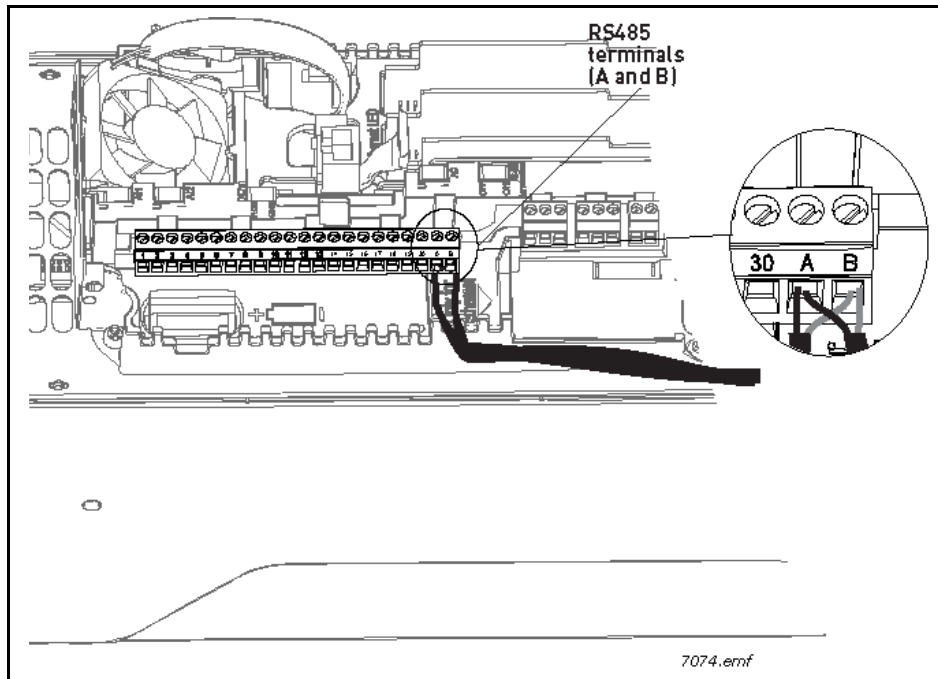

3

Using the cable clamp included in the delivery of the drive, ground the shield of the RS485 cable to the frame of the AC drive.

NOTE! This can be done in all drives if there is no difference in PE potential between the drives. However, if there is PE potential difference then the shield should be connected to PE only at one point in the system. The shields of the cables shall be joint but not connected to several PE points with different potential.

NOTE! This is only a principle drawing and the actual drive may look different.

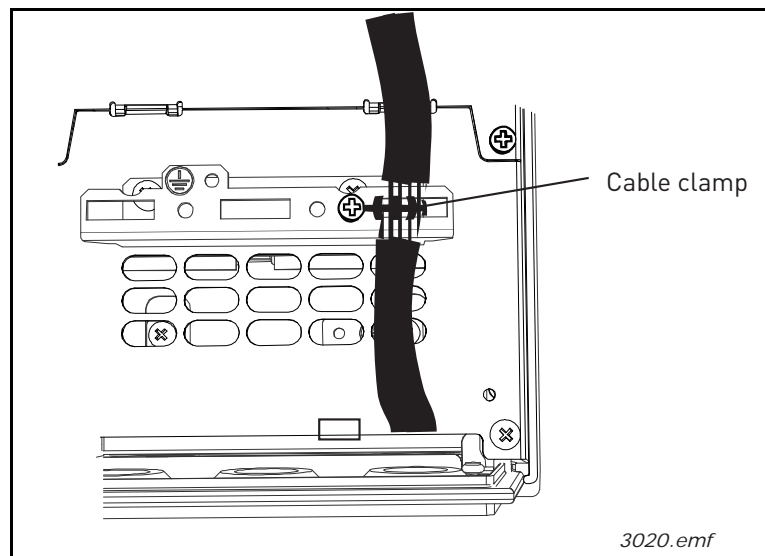

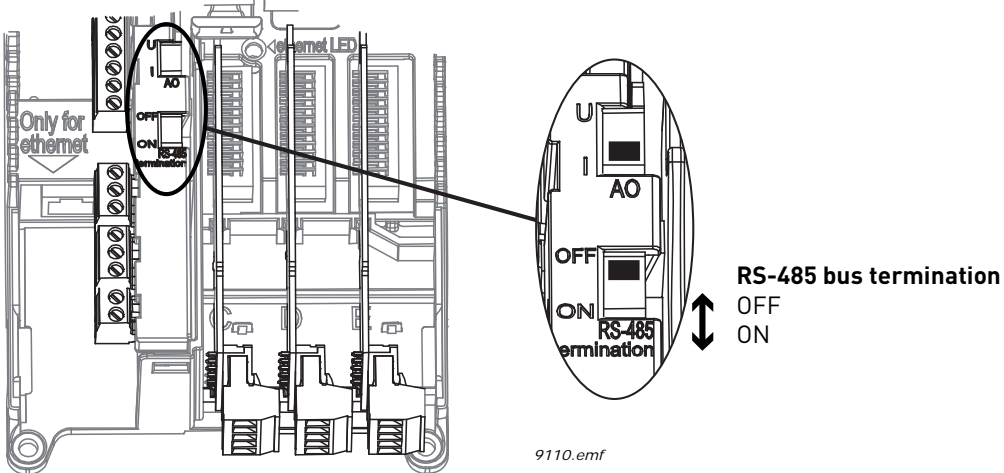
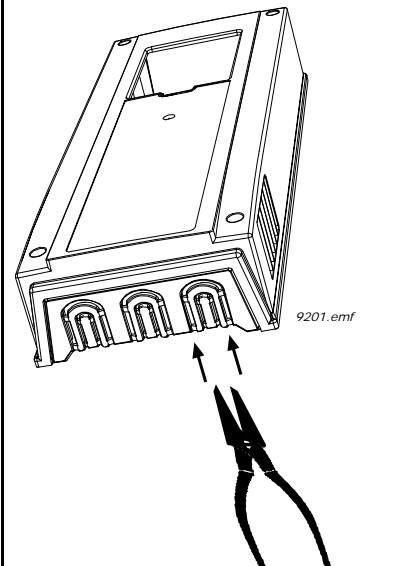
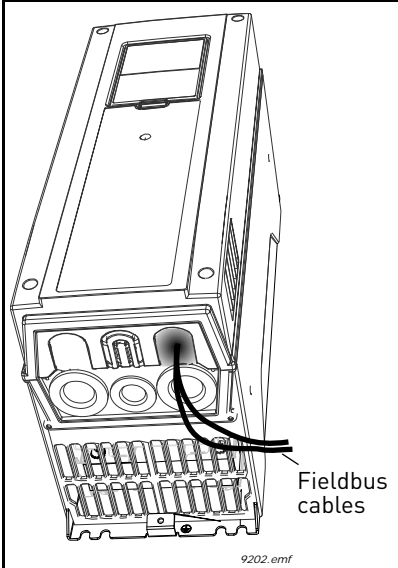
<p style="font-size: 2em; font-weight: bold; text-align: center;">4</p>	<p>If Vacon 100 is the last device on the bus, the bus termination must be set. Locate the DIP switches to the right of the control keypad of the drive and turn the switch for the RS485 bus termination resistor to position ON. Biasing is built in the termination resistor. See also step 6 on page 23.</p>  <p style="text-align: right; font-size: 0.8em;">9110.emf</p>
<p style="font-size: 2em; font-weight: bold; text-align: center;">5</p>	<p>Unless already done for the other control cables, cut free the opening on the AC drive cover for the RS485 cable (protection class IP21).</p> <p>NOTE! This is only a principle drawing and the actual drive may look different.</p>  <p style="text-align: right; font-size: 0.8em;">9201.emf</p>
<p style="font-size: 2em; font-weight: bold; text-align: center;">6</p>	<p>Remount the AC drive cover and run the RS485 cables as shown in picture.</p> <p>NOTE! When planning the cable runs, remember to keep the distance between the fieldbus cable and the motor cable at a minimum of 30 cm.</p>  <p style="text-align: right; font-size: 0.8em;">9202.emf</p>

7

The bus termination must be set for the first and the last device of the fieldbus line. See picture below. See also step 3 on page 22. It is recommended that the devices at the ends of the bus line have termination activated.

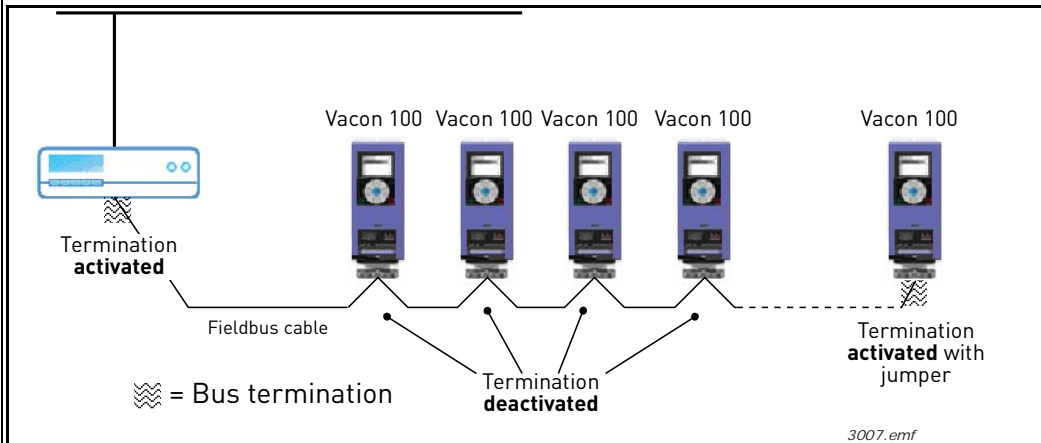

5.2 INSTALLATION IN VACON® 100 X

The AC drive can be connected to fieldbus either through RS485 or Ethernet. The connection for RS485 is on the standard I/O terminals (A and B) and the connection for Ethernet is left to the control terminals.

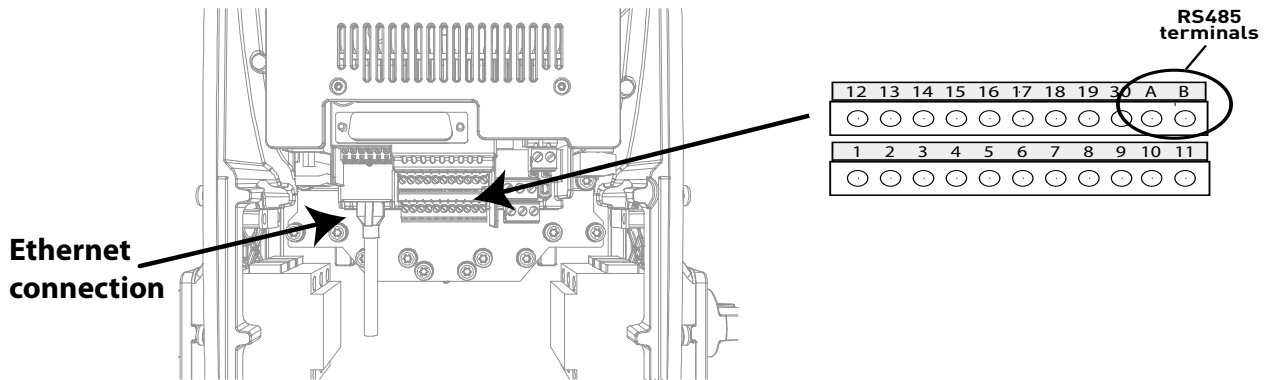

Figure 2.

5.2.1 PREPARE FOR USE THROUGH ETHERNET

- | | |
|----------|--|
| 1 | Connect the Ethernet cable (see specification in Chapter 3.2) to its terminal and run the cable through the conduit plate. |
| 2 | Remount the powerhead.
NOTE: When planning the cable runs, remember to keep the distance between the Ethernet cable and the motor cable at a minimum of 30 cm. |

For more detailed information, see the user’s manual of the fieldbus you are using.

5.2.2 PREPARE FOR USE THROUGH RS485

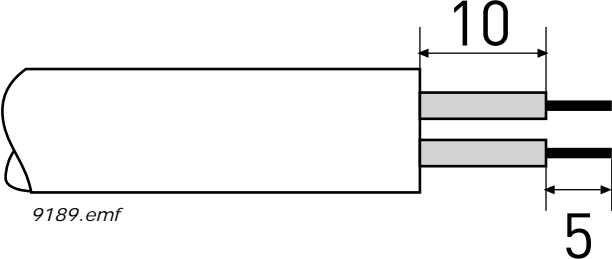
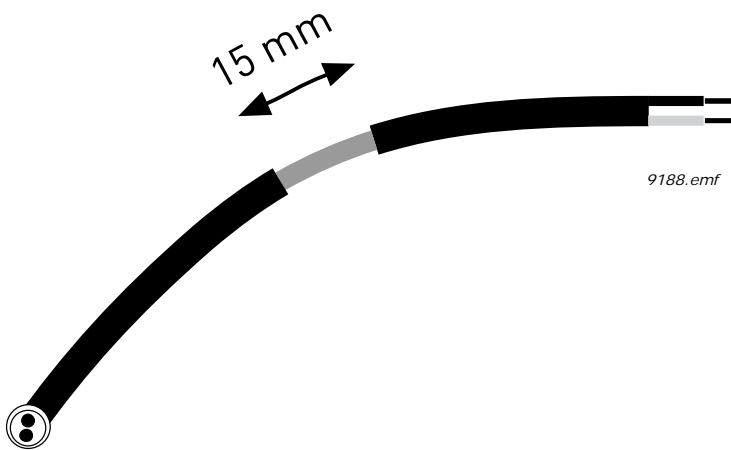
1	<p>Strip about 15 mm of the RS485 cable (see specification in Chapter 3.1) and cut off the grey cable shield. Remember to do this for both bus cables (except for the last device).</p> <p>Leave no more than 10 mm of the cable outside the terminal block and strip the cables at about 5 mm to fit in the terminals. See picture below.</p> <div style="text-align: center;">  <p>9189.emf</p> </div> <p>Also strip the cable now at such a distance from the terminal that you can fix it to the frame with the grounding clamp. Strip the cable at a maximum length of 15 mm. Do not strip the aluminum cable shield!</p> <div style="text-align: center;">  <p>9188.emf</p> </div>
---	--

2	<p>Then connect the cable to its appropriate terminals on VACON® 100 X AC drive standard terminal block, terminals A and B (A = negative, B = positive). See Figure 2.</p>
---	--

3	<p>Using the cable clamp included in the delivery of the drive, ground the shield of the RS485 cable to the frame of the AC drive.</p>
---	--

4

If VACON® 100 X AC drive is the last device on the bus, the bus termination must be set. Locate the DIP switches to the top of the control unit (see figure below).

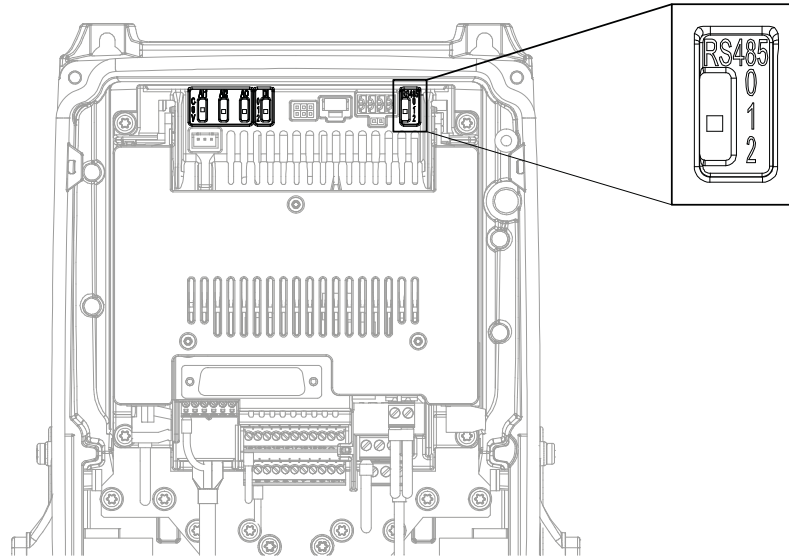

Turn the right most switch to position "1". Biasing is built in the termination resistor. See also step 6.

NOTE: When planning the cable runs, remember to keep the distance between the fieldbus cable and the motor cable at a **minimum of 30 cm**.

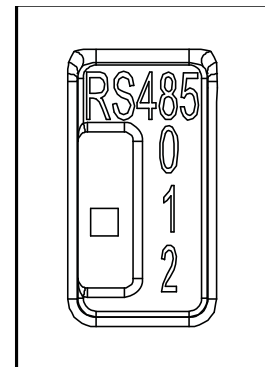

5

The bus termination must be set for the first and the last device of the fieldbus line. See picture below and step 4. We recommend that the first device on the bus and, thus, terminated, was the Master device.

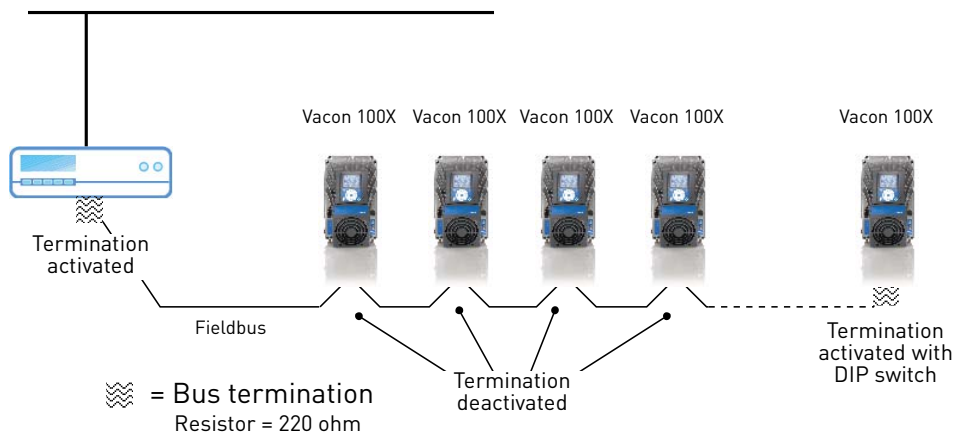

6. COMMUNICATIONS

6.1 OBJECT TYPES AND PROPERTIES SUPPORTED

Table 15. Object types and properties supported

Property	Object Type		
	Device	Binary Value	Analogue Value
Object_Identifier	X	X	X
Object_Name	X	X	X
Object_Type	X	X	X
System_Status	X		
Vendor_Name	X		
Vendor_Identifier	X		
Model_Name	X		
Firmware_Revision	X		
Application_Software_Version	X		
Description			
Protocol_Version	X		
Protocol_Revision	X		
Protocol_Services_Supported	X		
Protocol_Object_Types_Supported	X		
Object_List	X		
Max_APDU_Length_Accepted	X		
Segmentation_Supported	X		
Max_Segments_Accepted	X		
Local_Time	X		
Local_Date	X		
UTC_Offset	X		
Daylight_Savings_Status	X		
APDU_Segment_Timeout	X		
APDU_Timeout	X		
Number_Of_APDU_Retries	X		
Max_Master	X		
Max_Info_Frames	X		
Device_Address_Binding	X		
Database_Revision	X		
Active_COV_Subscriptions	X		
Event_State		X	X
Out_Of_Service		X	X
Present_Value		X	X
Priority_Array		X *	X *
Relinquish_Default		X *	X *
Status_Flags		X	X
COV_Increment			X
Units			X

*. Only with commandable values

6.1.1 BINARY VALUE OBJECT

Table 16.

Instance ID	Object Name	Description	Inactive / Active	Present Value Access Type
<i>BV0</i>	Ready State	Indicates whether the drive is ready or not	Not Ready / Ready	R
<i>BV1</i>	Run/Stop State	Indicates whether the drive is running or stopped	Stop / Run	R
<i>BV2</i>	Fwd/Rev State	Indicates the rotation direction of the motor	Fwd / Rev	R
<i>BV3</i>	Fault State	Indicates if a fault is active	OK / Fault	R
<i>BV4</i>	Alarm State	Indicates if an alarm is active	OK / Alarm	R
<i>BV5</i>	At Setpoint	Ref. Frequency reached	False / True	R
<i>BV6</i>	At Zero Speed	Motor Running at zero speed	False / True	R
<i>BV7</i>	fb_ProcessdataOut_01 Bit_0	ProcessDataOut1 bit 0	0 / 1	R
<i>BV8</i>	fb_ProcessdataOut_01 Bit_1	ProcessDataOut1 bit 1	0 / 1	R
<i>BV9</i>	fb_ProcessdataOut_01 Bit_2	ProcessDataOut1 bit 2	0 / 1	R
<i>BV10</i>	fb_ProcessdataOut_01 Bit_3	ProcessDataOut1 bit 3	0 / 1	R
<i>BV11</i>	fb_ProcessdataOut_01 Bit_4	ProcessDataOut1 bit 4	0 / 1	R
<i>BV12</i>	fb_ProcessdataOut_01 Bit_5	ProcessDataOut1 bit 5	0 / 1	R
<i>BV13</i>	fb_ProcessdataOut_01 Bit_6	ProcessDataOut1 bit 6	0 / 1	R
<i>BV14</i>	fb_ProcessdataOut_01 Bit_7	ProcessDataOut1 bit 7	0 / 1	R
<i>BV15</i>	Run/Stop CMD	Command to start drive (FB control is active)	Stop / Run	C
<i>BV16</i>	Fwd/Rev CMD	Command to run forward/reverse	Fwd/Rev	C
<i>BV17</i>	Reset Fault	Command to reset Active Fault from drive	0 / Reset	C
<i>BV18</i>	Stop By Coast	Stop Drive by coast	0 / 1	C
<i>BV19</i>	Stop By Ramp	Stop Drive by ramp	0 / 1	C
<i>BV20</i>	Quick Stop	Quick Stop	0 / 1	C
<i>BV21</i>	Zero Ramp	Stop by zero ramp	0 / 1	C
<i>BV22</i>	Hold Ramp	Hold ramp	0 / 1	C
<i>BV23</i>	BusCtrl	Activate Bus control	0 / 1	C
<i>BV24</i>	BusRef	Activate Bus reference	0 / 1	C
<i>BV25</i>	fb_control_word Bit_10	fb_control_word bit 10	0 / 1	C
<i>BV26</i>	fb_control_word Bit_11	fb_control_word bit 11	0 / 1	C
<i>BV27</i>	fb_control_word Bit_12	fb_control_word bit 12	0 / 1	C

Table 16.

<i>BV28</i>	fb_control_word Bit_13	fb_control_word bit 13	0 / 1	C
<i>BV29</i>	fb_control_word Bit_14	fb_control_word bit 14	0 / 1	C
<i>BV30</i>	fb_control_word Bit_15	fb_control_word bit 15	0 / 1	C

NOTE! Present Value Access Types: **R** = Read-only, **W** = Writeable, **C** = Commandable. Commandable values support priority arrays & relinquish defaults.

6.1.2 ANALOGUE VALUE OBJECT

Table 17.

Instance ID	Object Name	Description	Units	Present Value Access Type
<i>AV0</i>	Frequency Setpoint	Frequency Setpoint	Hz	R
<i>AV1</i>	Output Frequency	Output Frequency	Hz	R
<i>AV2</i>	Motor Speed	Motor Speed	rpm	R
<i>AV3</i>	Load (power)	Motor Shaft Power	%	R
<i>AV4</i>	Kilowatt Hours total	Kilowatt Hour Counter (Total)	kWh	R
<i>AV5</i>	Motor Current	Motor Current	A	R
<i>AV6</i>	DC link Voltage	DC link Voltage	V	R
<i>AV7</i>	Motor Voltage	Motor Voltage	V	R
<i>AV8</i>	Unit Temperature	Heatsink Temperature	°C	R
<i>AV9</i>	Motor Torque	In % of motor nominal Torque	%	R
<i>AV10</i>	Operating Days	Operating Days (resettable)	Day	R
<i>AV11</i>	Operating Hours	Operating Hours (resettable)	Hour	R
<i>AV12</i>	Kilowatt Hours	Kilowatt Hours (resettable)	kWh	R
<i>AV13</i>	Torque Reference	Torque Reference	%	R
<i>AV14</i>	Temperature Rise	Calculated motor temperature 100,0% = nominal temperature of motor	%	R
<i>AV15</i>	fb_ProcessdataOut_01	Application specific ²⁾		R
<i>AV16</i>	fb_ProcessdataOut_02	Application specific ²⁾		R
<i>AV17</i>	fb_ProcessdataOut_03	Application specific ²⁾		R
<i>AV18</i>	fb_ProcessdataOut_04	Application specific ²⁾		R
<i>AV19</i>	fb_ProcessdataOut_05	Application specific ²⁾		R
<i>AV20</i>	fb_ProcessdataOut_06	Application specific ²⁾		R

Table 17.

AV21	fb_ProcessdataOut_07	Application specific ²⁾		R
AV22	fb_ProcessdataOut_08	Application specific ²⁾		R
AV23	Active Fault Code	Active Fault Code	-	R
AV24	Speed Reference	Speed Reference, percentage of nominal speed	%	C
AV25	Current Limit	Current Limit	A	W
AV26	Min Frequency	Minimum Frequency	Hz	W
AV27	Maximum Frequency	Maximum Frequency	Hz	W
AV28	Accel Time	Acceleration Time	s	W
AV29	Decel Time	Deceleration Time	s	W
AV30	fb_ProcessdataIn_01	Application specific ²⁾		C
AV31	fb_ProcessdataIn_02	Application specific ²⁾		C
AV32	fb_ProcessdataIn_03	Application specific ²⁾		C
AV33	fb_ProcessdataIn_04	Application specific ²⁾		C
AV34	AnyParam ID	ID number that is used in AV35	0 to 65535 resolution 1	W
AV35	AnyParam Value	Value of ID defined by AV34	32 bits Value	W
AV36 ¹⁾	Fb_Control_Word Lo16	Fixed Control Word First 16 bits 0-15	range 65535 - 0	C
AV37 ¹⁾	Fb_Control_Word Hi16	Fixed Control Word Last 16 bits 16-31	range 65535 - 0	C
AV38	Fb_Status_Word Lo16	Fixed Status Word First 16 bits 0-15	range 65535 - 0	R
AV39	Fb_Status_Word Hi16	Fixed Status Word Last 16 bits 16-31	range 65535 - 0	R

1) ANSI/IEEE-754 floating point. Binary coding can be done only if the value has no decimals.

2) Map only analog data to these objects. If binary coded data is mapped into these objects, the data may be invalid because of ANSI/IEEE-754 floating point to 32bit integer conversion.

NOTE! Present Value Access Types: **R** = Read-only, **W** = Writeable, **C** = Commandable. Commandable values support priority arrays & relinquish defaults.

High and Low limits for the objects are defined in the application. See corresponding application for exact limits.

6.2 CONTROL WORD BITS

Table 18. Control Word bits

Bit	Name	Value = 1	Value = 0	Description
B0	Start/Stop	Start request	Stop request	Start/Stop command to application
B1	Fwd/Rev	Reverse direction	Forward direction	Controls the direction of motor axis rotation
B2	Fault reset	Reset faults	No action	Command to reset fault
B3-B15	Not used			

6.3 STATUS WORD BITS

Table 19. Status Word bits

Bit	Name	Value = 1	Value = 0	Description
B0	Ready	Ready	Not ready	Indicates whether the drive is ready or not
B1	Run	Running	Stop	Indicates whether the drive is running or stopped
B2	Direction	Counterclockwise	Clockwise	Indicates the rotation direction of the motor
B3	Fault	Faulted	Not faulted	Indicates if a fault is active
B4	Alarm	Alarm	No alarm	Indicates if an alarm is active
B5	AtReference	True	False	Reference frequency reached
B6	ZeroSpeed	True	False	Motor running at zero speed
B7-B15	Not used			

7. FAULT TRACING

When an unusual operating condition is detected by the AC drive control diagnostics, the drive initiates a notification visible, for example, on the keypad. The keypad will show the ordinal number of the fault, the fault code and a short fault description.

The fault can be reset with the Reset button on the control keypad or via the I/O terminal. The faults are stored in the Fault history menu, which can be browsed. The different fault codes you will find in the table below. This fault table presents only the faults related to the fieldbus in use.

NOTE! When contacting distributor or factory because of a fault condition, always write down all texts and codes on the keypad display and send a description of the problem together with the *Drive Info File* to tech.supportVDF@vacon.com.

7.1 TYPICAL FAULT CONDITIONS

Table 20. Typical fault conditions

Fault condition	Possible cause	Remedy
Termination resistor	Missing or excessive termination resistor.	Install termination resistors at both ends of the fieldbus line.
Cabling	<ul style="list-style-type: none"> • Supply or motor cables are located too close to the fieldbus cable • Wrong type of fieldbus cable • Too long cabling 	
Grounding	Inadequate grounding.	Ensure grounding in all points on the net
Connections	Faulty connections: <ul style="list-style-type: none"> • Excessive stripping of cables • Conductors in wrong terminals • Too loose connections of conductors 	
Parameter	<ul style="list-style-type: none"> • Faulty address • Overlapping slave addresses • Wrong baud rate • Wrong control place selected 	

7.2 OTHER FAULT CONDITIONS

The following fault tracing diagram will help you to locate and fix some of the most usual problems. If the problem persists contact your local distributor.

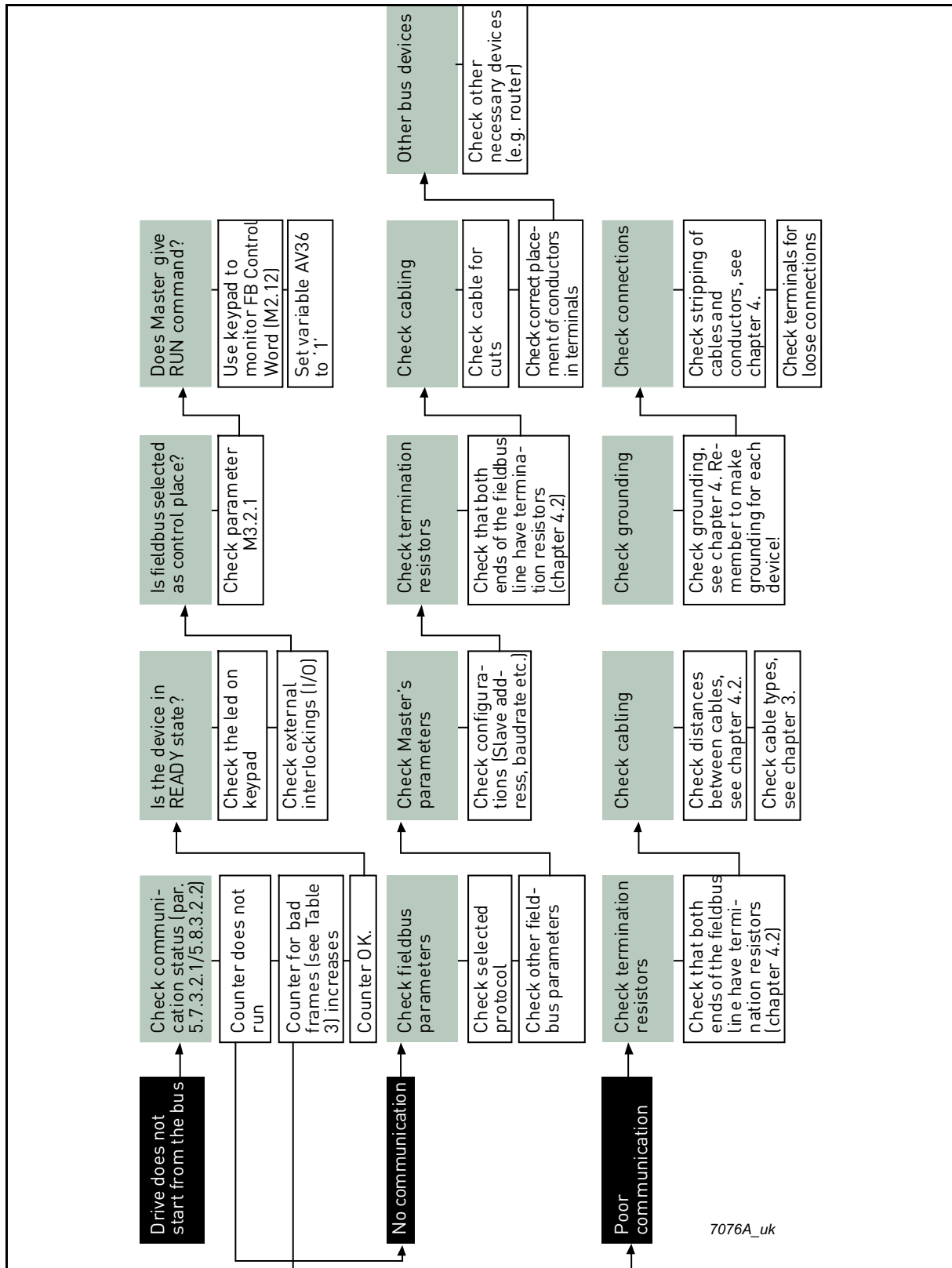
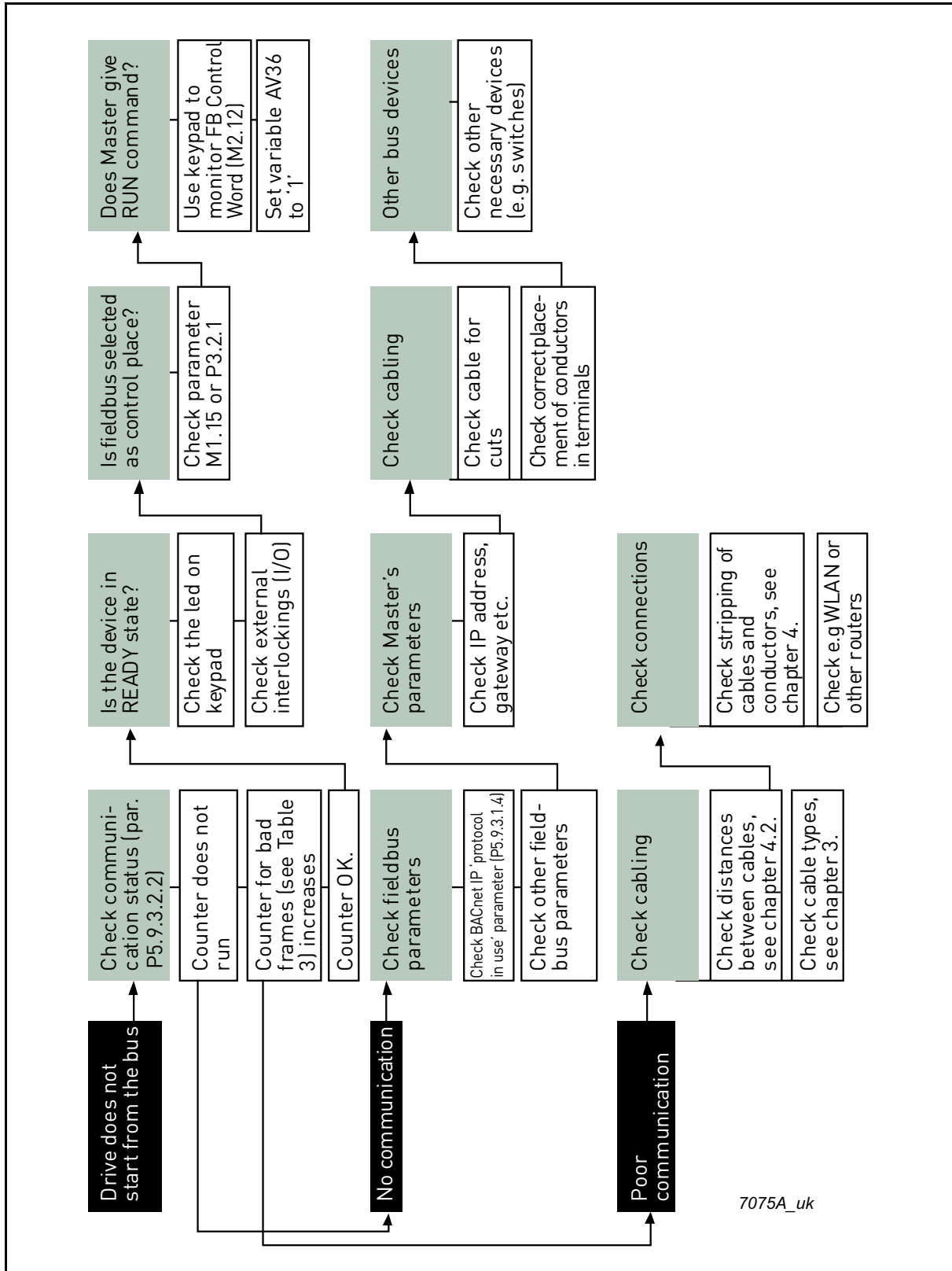

Figure 3. Fault tracing diagram for BACnet MS/TP



7075A_uk

Figure 4. Fault tracing diagram for BACnet IP

8. QUICK SETUP

Following these instructions, you can easily and fast set up your BACnet bus for use.

1	<p>Choose control place.</p> <p>A. To select <i>Remote Control Place</i>, press LOC/REM button on the keypad on Vacon 100 HVAC, and FUNCT button on Vacon 100 and Vacon 100 FLOW.</p> <p>B. Select <i>Fieldbus</i> as remote control place: <i>Main Menu > Parameters (M3) > Start/Stop Setup (M3.2) > Rem. Ctrl. Place (P3.2.1)</i>.</p>
2	<p>Make these settings in the master software.</p> <p>A. Set <i>Control Word</i> to '0' (AV36 Fb_Control_Word_Lo16).</p> <p>B. Set <i>Control Word</i> to '1' (AV36 Fb_Control_Word_Lo16).</p> <p>C. AC drive status is RUN.</p> <p>D. Set Reference value to '50' (50.00%) (AV24 Speed Reference).</p> <p>E. <i>Frequency setpoint</i> is 25.00 Hz (if MinFreq is 0.00 Hz and MaxFreq is 50.00 Hz)</p> <p>F. Set <i>Control Word</i> to '0' (AV36 Fb_Control_Word_Lo16).</p> <p>G. AC drive status is STOP.</p>

9. ANNEX - PROTOCOL IMPLEMENTATION CONFORMANCE STATEMENT

PROTOCOL IMPLEMENTATION CONFORMANCE STATEMENT (NORMATIVE)

(This annex is part of this Standard and is required for its use.)

BACnet Protocol Implementation Conformance Statement

Date: December 17, 2014

Vendor Name: Vacon

Product Name: Vacon 100

Product Model Number: Vacon 100, Vacon 100 X, Vacon FLOW

Applications Software Version: 1.0

Firmware Revision: 1.0

BACnet Protocol Revision: 12

Product Description: Vacon 100 Variable Frequency Drive (VFD) product range contains the following models based on the same software: Vacon 100, Vacon 100 FLOW, Vacon 100 X

BACnet Standardized Device Profile (Annex L): BACnet Application Specific Controller (B-ASC)

List all BACnet Interoperability Building Blocks Supported (Annex K): DS-RP-B, DS-RPM-B, DS-WP-B, DS-WPM-B, DS-COV-B, DM-TS-B, DM-UTC-B, DM-RD-B, DM-DDB-B, DM-DOB-B, DM-DCC-B.

Segmentation Capability:

- Segmented requests supported Window Size 8
- Segmented responses supported Window Size 8

Standard Object Types Supported:

Vacon 100 product range supports:

- Device Object
- Analog Value Object
- Binary Value Object

The Analog Values that are *commandable* contain the *priority array* and *relinquish default* properties. All Analog Values that are not *commandable* become writable when the *out of service* property is set to true.

The Binary Values that are *commandable* contain the *priority array* and *relinquish default* properties. All Binary Values that are not *commandable* become writable when *out of service* property is set to true.

Device Object

Object property	Readable	Writable
object-identifier	x	
object-name	x	
object-type	x	
system-status	x	
vendor-name	x	
vendor-identifier	x	
model-name	x	
firmware-revision	x	
application-software-version	x	
description	x	
protocol-version	x	
protocol-revision	x	
protocol-services-supported	x	
protocol-object-types-supported	x	
object-list	x	
max-apdu-length-accepted	x	
segmentation-supported	x	
max-segments-accepted	x	
local-time	x	
local-date	x	
apdu-segment-timeout	x	
apdu-timeout	x	
number-of-apdu-retries	x	
max-master	x	
max-info-frames	x	
device-address-binding	x	

Object property	Readable	Writable
database-revision	x	
active-cov-subscriptions	x	

Analog Value Object

Analog Value Object - Commandable			
Object property	Readable	Writable	Commandable
object-identifier	x		
object-name	x		
object-type	x		
present-value	x		x
status-flags	x		
event-state	x		
out-of-service	x	x	
units	x		
priority-array	x		
relinquish-default	x	x	
cov-increment	x	x	

Analog Value Object - writable when out-of-service is set true		
Object property	Readable	Writable
object-identifier	x	
object-name	x	
object-type	x	
present-value	x	* x Normally 'read only' but becomes writable when out-of-service set to true
status-flags	x	
event-state	x	
out-of-service	x	x
units	x	
cov-increment	x	x

Binary Value Object

Binary Value Object - Commandable			
Object property	Readable	Writable	Commandable
object-identifier	x		
object-name	x		
object-type	x		
present-value	x		x
status-flags	x		
event-state	x		
out-of-service	x	x	
priority-array	x		
relinquish-default	x	x	

Binary Value Object - writable when out-of-service is set true		
Object property	Readable	Writable
object-identifier	x	
object-name	x	
object-type	x	
present-value	x	* x Normally 'read only' but becomes writable when out-of-service set to true
status-flags	x	
event-state	x	
out-of-service	x	x
priority-array	x	
relinquish-default	x	x

Data Link Layer Options:

MS/TP master (Clause 9), baud rate(s): 9600,19200,34800, 76800 (supports autobaud detection)
 BACnet IP, (Annex J), Foreign Device

Device Address Binding:

Is static device binding supported? (This is currently necessary for two-way communication with MS/TP slaves and certain other devices.) Yes No

Networking Options:

- Router, Clause 6 - List all routing configurations, e.g., ARCNET-Ethernet, Ethernet-MS/TP, etc.
- Annex H, BACnet Tunneling Router over IP
- BACnet/IP Broadcast Management Device (BBMD)

Character Sets Supported:

Indicating support for multiple character sets does not imply that they can all be supported simultaneously.

- ISO 10646 (UTF-8) IBM™ /Microsoft™ DBCS ISO 8859-1
- ISO 10646 (UCS-2) ISO 10646 (UCS-4) JIS X 0208

VACON[®]

DRIVEN BY DRIVES

Find your nearest Vacon office
on the Internet at:

www.vacon.com



Manual authoring:
documentation@vacon.com

Vacon Plc.
Runsorintie 7
65380 Vaasa
Finland

Subject to change without prior notice
© 2015 Vacon Plc.

Document ID:



Rev. C

Sales code: DOC-INSBACNET+DLUK