

VACON[®] 100
AC DRIVES

INSTALLATION MANUAL
ENCLOSED DRIVES

VACON[®]

PREFACE

Document ID: DPD01666B

Date: 6.10.2015

ABOUT THIS MANUAL

This manual is copyright of Vacon Plc. All Rights Reserved.

ABOUT THE PRODUCT

This manual describes the Vacon 100 Enclosed Drive. The power range of the drive is between 75-800 kW, and its voltage range is 380-500 V or 525-690 V. The drive comes installed in a cabinet, and is available in 4 different frame sizes: MR8, MR9, MR10 and MR12. The drive can include 1 or more cabinets.

The drive is available in 2 regional variations: IEC (qualified to the IEC criteria) or NAM, North America (qualified to the UL criteria).

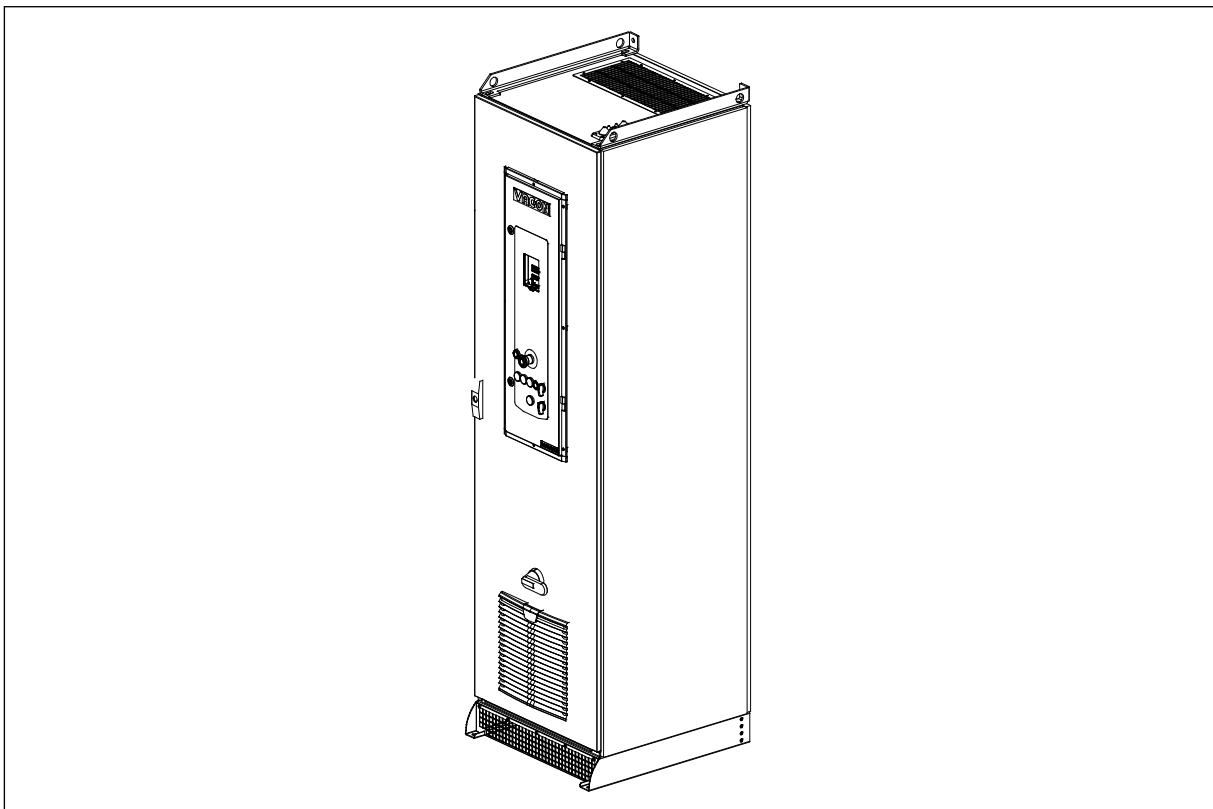

Fig. 1: An example of the Vacon 100 Enclosed Drive

TABLE OF CONTENTS

Preface

About this manual	3
About the product	3
1 Approvals	7
2 Safety	9
2.1 The safety symbols used in the manual and the drive	9
2.2 Warning	9
2.3 Caution	10
2.4 Grounding and earth fault protection	11
2.5 Using an RCD or an RCM device	12
3 Receiving the delivery	13
3.1 Package label	13
3.2 Type designation code	14
3.3 The contents of the delivery	14
3.4 Storage	14
3.5 Removing the packaging and lifting the AC drive	15
3.5.1 Weight of the AC drive	15
3.5.2 Lifting the AC drive	15
3.6 "Product modified" label	17
3.7 Disposal	17
4 Mounting	18
4.1 Dimensions of the cabinet, IEC	18
4.2 Dimensions of the cabinet, NAM	20
4.3 The options	24
4.4 Installation of the cabinet	29
4.5 Cooling and free space around the AC drive	30
4.6 The optional back channel cooling	32
4.6.1 Using the back channel for cooling	32
5 Power cabling	35
5.1 Cable dimensioning and selection	35
5.1.1 Cable and fuse sizes, IEC	35
5.1.2 Cable and fuse sizes, NAM	42
5.2 Brake resistor cables	48
5.3 Preparing for the cable installation	50
5.4 Cable installation in MR8-MR12	51
5.4.1 Installing the cables	55
6 Control compartment	60
6.1 The control compartment of the enclosed drive	60
6.2 Fieldbus connection	63
6.2.1 Using fieldbus through an Ethernet cable	63
6.2.2 Using fieldbus through an RS485 cable	64

7	Commissioning and additional instructions	68
7.1	Commissioning safety	68
7.2	Operation of the motor	69
7.2.1	Checks before starting the motor	69
7.3	Measuring the cable and motor insulation	69
7.4	Installation in a marine environment	69
7.5	Installation in an IT system	69
7.5.1	The EMC jumper in MR8	70
7.5.2	The EMC jumper in MR9	71
7.5.3	The EMC jumper in MR10 and MR12	73
7.6	Maintenance	74
7.6.1	Maintenance intervals	74
7.6.2	Replacing the air filters of the AC drive	75
7.6.3	Replacing the fans of the AC drive	76
7.6.4	Replacing the power unit of the AC drive	81
7.6.5	Downloading the software	90
8	Technical data, Vacon® 100	94
8.1	AC drive power ratings	94
8.1.1	Mains voltage 380-500 V	94
8.1.2	Mains voltage 525-690 V	95
8.1.3	Brake resistor ratings	95
8.2	Vacon® 100 - technical data	99
9	Technical data, Vacon® 100 FLOW	104
9.1	AC drive power ratings	104
9.1.1	Mains voltage 380-500 V	104
9.1.2	Mains voltage 525-690 V	105
9.2	Vacon® 100 FLOW - technical data	106
10	Technical data on control connections	111
10.1	Technical data on control connections	111

1 APPROVALS

Here are the approvals that have been granted to this Vacon product.

1. EC Declaration of conformity
 - Find the EC Declaration of Conformity on the next page.
2. UL approval *
 - cULus approval file number E171278.

* The UL approval is valid for input voltage up to 600 V.



EC DECLARATION OF CONFORMITY

We

Manufacturer's name: Vacon Oyj
Manufacturer's address: P.O. Box 25
 Runsorintie 7
 FIN-65381 Vaasa
 Finland

hereby declare that the product

Product name: Vacon 100 AC drive
Model Designation: **Wall-Mounted Drives:**
 Vacon 0100 3L 0003 2...0310 2
 Vacon 0100 3L 0003 4...0310 4
 Vacon 0100 3L 0003 5...0310 5
 Vacon 0100 3L 0004 6...0208 6
 Vacon 0100 3L 0007 7...0208 7
IP00 Drives:
 Vacon 0100 3L 0140 2...0310 2
 Vacon 0100 3L 0140 5...1180 5
 Vacon 0100 3L 0080 6...0820 6
 Vacon 0100 3L 0080 7...0820 7
Enclosed Drives:
 Vacon 0100 3L 0140 5...0590 5
 Vacon 0100 3L 0080 7...0820 7

has been designed and manufactured in accordance with the following standards:

Safety: EN 61800-5-1: 2007
 EN 60204-1: 2009 (as relevant)
EMC: EN 61800-3: 2004 + A1: 2012
 EN 61000-3-12

and conforms to the relevant safety provisions of the Low Voltage Directive (2006/95/EC) and EMC Directive 2004/108/EC.

It is ensured through internal measures and quality control that the product conforms at all times to the requirements of the current Directive and the relevant standards.

In Vaasa, 31st of March, 2015

Vesa Laisi
 President

The year the CE marking was affixed: 2009





2 SAFETY

2.1 THE SAFETY SYMBOLS USED IN THE MANUAL AND THE DRIVE

This manual contains warnings and cautions, which are identified with safety symbols. The warnings and cautions give important information on how to prevent injury and damage to the equipment or your system.

Read the warnings and cautions carefully and obey their instructions.

Table 1: The safety symbols

The safety symbol	Description
	WARNING!
	CAUTION!
	HOT SURFACE!
	READ THE MANUAL!
	WAIT 5 MINUTES!

2.2 WARNING



WARNING!

Do not touch the components of the power unit when the drive is connected to mains. The components are live when the drive is connected to mains. A contact with this voltage is very dangerous.

**WARNING!**

Do not touch the motor cable terminals U, V, W, the brake resistor terminals or the DC terminals when the drive is connected to mains. These terminals are live when the drive is connected to mains, also when the motor does not operate.

**WARNING!**

Do not touch the control terminals. They can have a dangerous voltage also when the drive is disconnected from mains.

**WARNING!**

Before you do electrical work, make sure that there is no voltage in the components of the drive.

**WARNING!**

To do work on the terminal connections of the drive, disconnect the drive from mains and make sure that the motor has stopped. Wait 5 minutes before you open the cabinet door or the cover of the drive. Then use a measuring device to make sure that there is no voltage. The terminal connections and the components of the drive are live 5 minutes after it is disconnected from mains and the motor has stopped.

**WARNING!**

Before you connect the drive to mains, make sure that the front cover and the cable cover of the drive are closed. The connections of the AC drive are live when the drive is connected to mains.

**WARNING!**

Disconnect the motor from the drive if an accidental start can be dangerous. When there is a power-up, a power break or a fault reset, the motor starts immediately if the start signal is active, unless the pulse control for Start/Stop logic is selected. If the parameters, the applications or the software change, the I/O functions (including the start inputs) can change.

**WARNING!**

Wear protective gloves when you do mounting, cabling or maintenance operations. There can be sharp edges in the AC drive that can cause cuts.

2.3 CAUTION**CAUTION!**

Do not move the AC drive. Use a fixed installation to prevent damage to the drive.

**CAUTION!**

Do not make measurements when the AC drive is connected to mains. It can cause damage to the drive.

**CAUTION!**

Make sure that there is reinforced protective ground connection. It is mandatory, because the touch current of the AC drives is more than 3.5 mA AC (refer to EN 61800-5-1). See chapter 2.4 *Grounding and earth fault protection*.

**CAUTION!**

Do not use spare parts that are not from the manufacturer. Using other spare parts can cause damage to the drive.

**CAUTION!**

Do not touch the components on the circuit boards. Static voltage can cause damage to these components.

**CAUTION!**

Make sure that the EMC level of the AC drive is correct for your mains. See chapter 7.5 *Installation in an IT system*. An incorrect EMC level can cause damage to the drive.

**CAUTION!**

Prevent radio interference. The AC drive can cause radio interference in a domestic environment.

**NOTE!**

If you activate the autoreset function, the motor starts automatically after an automatic fault reset. See the Application Manual.

**NOTE!**

If you use the AC drive as a part of a machine, the machine manufacturer must supply a mains disconnection device (refer to EN 60204-1).

2.4 GROUNDING AND EARTH FAULT PROTECTION

**CAUTION!**

The AC drive must always be grounded with a grounding conductor that is connected to the grounding terminal that is identified with the symbol \oplus . Not using a grounding conductor can cause damage to the drive.

The touch current of the drive is more than 3.5 mA AC. The standard EN 61800-5-1 tells that 1 or more of these conditions for the protective circuit must be true.

The connection must be fixed.

- a) The protective grounding conductor must have a cross-sectional area of minimum 10 mm² Cu or 16 mm² Al. OR
- b) There must be an automatic disconnection of the mains, if the protective grounding conductor breaks. See chapter 5 *Power cabling*. OR
- c) There must be a terminal for a second protective grounding conductor in the same cross-sectional area as the first protective grounding conductor.

Table 2: Protective grounding conductor cross-section

Cross-sectional area of the phase conductors (S) [mm ²]	The minimum cross-sectional area of the protective grounding conductor in question [mm ²]
$S \leq 16$	S
$16 < S \leq 35$	16
$35 < S$	S/2

The values of the table are valid only if the protective grounding conductor is made of the same metal as the phase conductors. If this is not so, the cross-sectional area of the protective grounding conductor must be determined in a manner that produces a conductance equivalent to that which results from the application of this table.

The cross-sectional area of each protective grounding conductor that is not a part of the mains cable or the cable enclosure, must be a minimum of:

- 2.5 mm² if there is mechanical protection, and
- 4 mm² if there is not mechanical protection. If you have cord-connected equipment, make sure that the protective grounding conductor in the cord is the last conductor to be interrupted, if the strain-relief mechanism breaks.

Obey the local regulations on the minimum size of the protective grounding conductor.

**NOTE!**

Because there are high capacitive currents in the AC drive, it is possible that the fault current protective switches do not operate correctly.

**CAUTION!**

Do not do voltage withstand tests on the AC drive. The manufacturer has already done the tests. Doing voltage withstand tests can cause damage to the drive.

2.5 USING AN RCD OR AN RCM DEVICE

The drive can cause a current in the protective grounding conductor. You can use a residual current-operated protective (RCD) device, or a residual current-operated monitoring (RCM) device to give protection against a direct or an indirect contact. Use a type B RCD or RCM device on the mains side of the drive.

NOTE! You can download the English and French product manuals with applicable safety, warning and caution information from www.vacon.com/downloads.

REMARQUE Vous pouvez télécharger les versions anglaise et française des manuels produit contenant l'ensemble des informations de sécurité, avertissements et mises en garde applicables sur le site www.vacon.com/downloads.

3 RECEIVING THE DELIVERY

Before a Vacon® AC drive is sent to the customer, the manufacturer makes many tests on the drive. However, after you remove the packaging, examine the drive for transport damages.

If the drive was damaged during the shipping, speak to the cargo insurance company or the carrier.

To make sure that the contents of the delivery is correct and complete, compare the type designation of the product to the type designation code. See Chapter 3.2 *Type designation code*.

3.1 PACKAGE LABEL

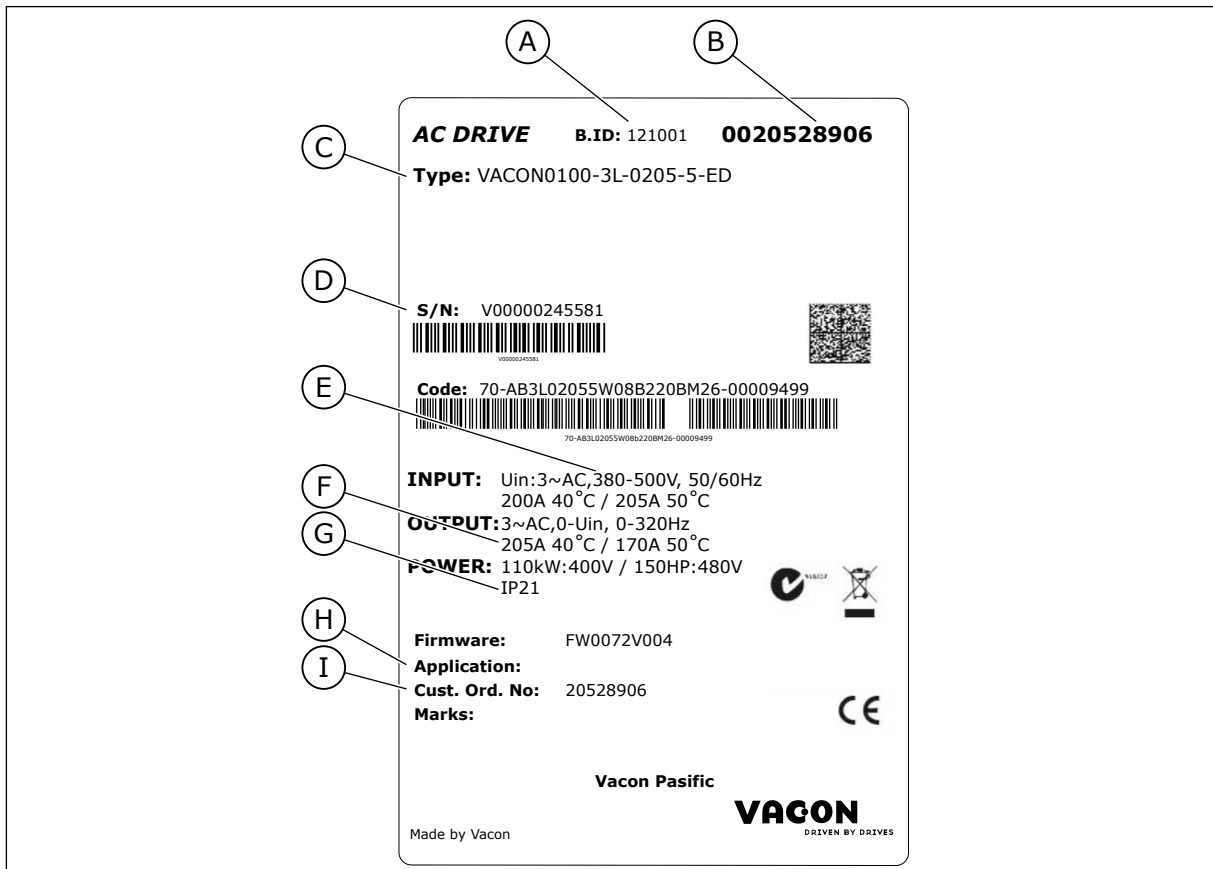

Fig. 2: The package label of Vacon AC drives

- | | |
|------------------------------|-------------------------------------|
| A. The batch ID | F. The nominal output current |
| B. The order number of Vacon | G. The IP class |
| C. The type designation code | H. The application code |
| D. The serial number | I. The order number of the customer |
| E. The mains voltage | |

3.2 TYPE DESIGNATION CODE

The type designation code of Vacon is made of standard codes and optional codes. Each part of the type designation code agrees to the data in your order. The code can have this format, for example:

VACON0100-3L-0385-5-ED

In chapter 4.3 *The options* you will find descriptions of the option codes.

Table 3: The description of the parts in the type designation code

Code	Description
VACON	This part is same for all the products.
0100	The product range: 0100 = Vacon 100
3L	Input/Function: 3L = A 3-phase input
0385	The drive rating in amperes. For example, 0385 = 385 A
5	The mains voltage: 5 = 380-500 V 7 = 525-690 V
FLOW	The Vacon 100 FLOW AC drive
ED	The AC drive is enclosed in a cabinet

You can find the type designation code on a label in the lower right corner of the control compartment door.

3.3 THE CONTENTS OF THE DELIVERY

The contents of the delivery, MR8-MR12

- The enclosed drive
- An accessories bag
- Installation Manual, Application Manual and manuals for the options that you ordered
- Order-specific documents

3.4 STORAGE

The storage conditions

- Temperature: -40 °C...+70 °C
- Humidity: < 95%, no condensation

If you keep the package in storage for more than 2 months, keep it in controlled conditions. Make sure that the temperature variation is small and that the humidity is less than 50%.

3.5 REMOVING THE PACKAGING AND LIFTING THE AC DRIVE

3.5.1 WEIGHT OF THE AC DRIVE

The weights of AC drives of different frames are very different. It can be necessary for you to use a lifting device to move the drive from its package.

Table 4: The default weight of the enclosed drive and some options

Frame	IP21/IP54 [kg]	Common mode filter + du/dt filter [kg]	Top cabling sections [kg]
MR8	200	30	65
MR9	270	40	65
MR10	420	40	80
MR12	825	80	95

3.5.2 LIFTING THE AC DRIVE

The AC drive is delivered horizontally on a wooden pallet.

MOVING THE ENCLOSED DRIVE

- 1 Do not remove the package material before you install the AC drive.
- 2 Put the drive onto a level base.
- 3 Move the drive in the vertical position.
- 4 Use a hoist to move the drive.

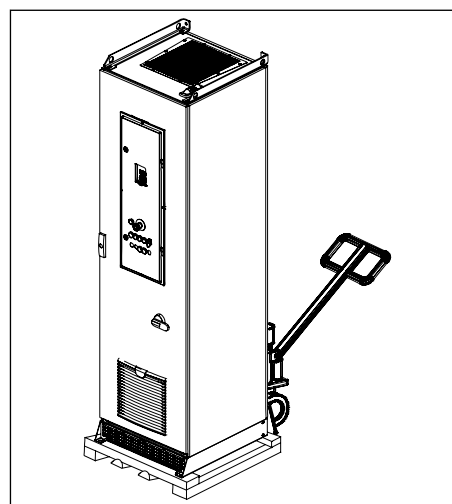

- 5 If you move more than 1 drive at a time, use rollers.

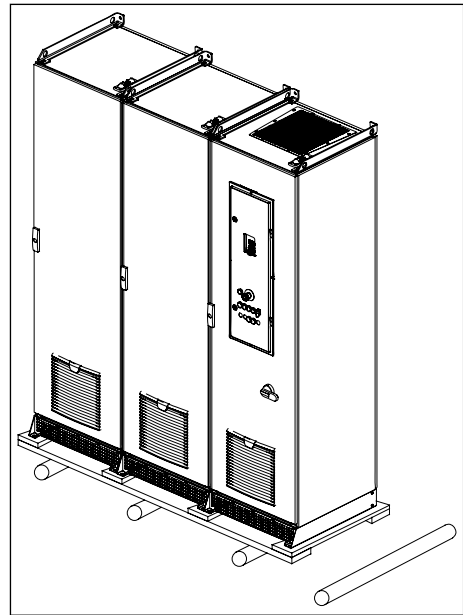

LIFTING THE ENCLOSED DRIVE

- 1 Remove the drive from the package.

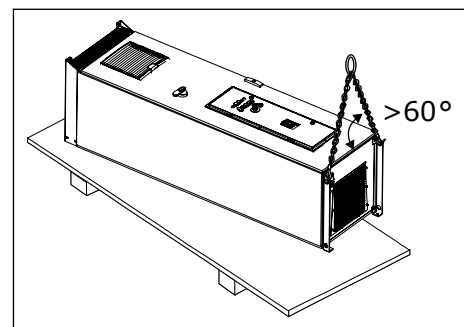

- 2 Use a lifting device that is sufficiently strong for the weight of the drive.
- 3 Put the lifting hooks in the holes on the top of the cabinet.
- 4 The minimum angle between the drive and the chain is 60 degrees.

- Lift the drive into a vertical position.

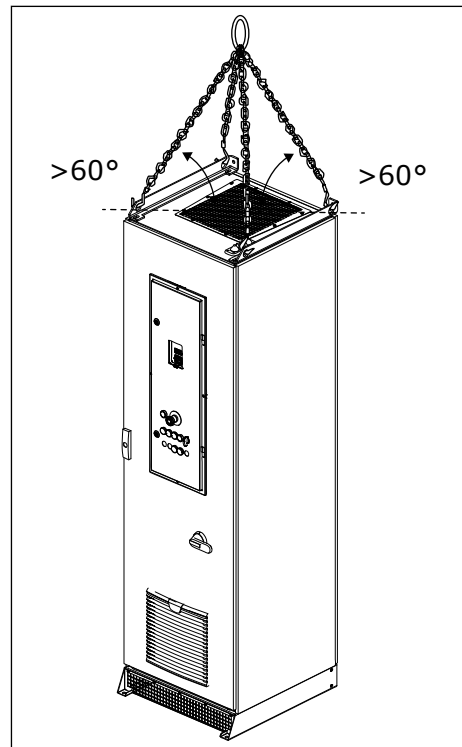

3.6 "PRODUCT MODIFIED" LABEL

In the accessories bag, there is also a "product modified" label. The function of the label is to tell the service personnel about the changes that are made in the AC drive. Attach the label on the side of the AC drive to know where to find it. If you make changes in the AC drive, write the change on the label.

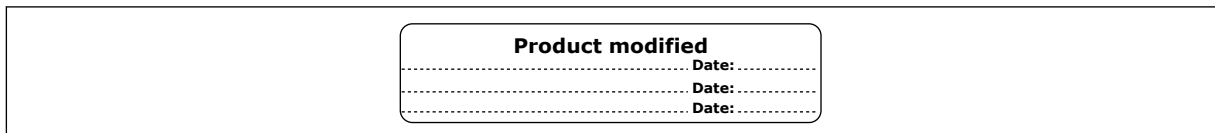

3.7 DISPOSAL

	<p>When the drive is at the end of its operation life, do not discard it as a part of municipal waste. You can recycle the primary components of the drive. You must disassemble some components before you can remove the different materials. Recycle the electrical and electronic components as waste.</p> <p>To make sure that the waste is recycled correctly, send the waste to a recycling centre. You can also send the waste back to the manufacturer.</p> <p>Obey the local and other applicable regulations.</p>
--	------------------------------------------------------------------------------------------------------------------------------------------------------------------------------------------------------------------------------------------------------------------------------------------------------------------------------------------------------------------------------------------------------------------------------------------------------------------------------------------------------------------------------

4 MOUNTING

4.1 DIMENSIONS OF THE CABINET, IEC

Install the AC drive in a vertical position on level ground. Attach the drive with screws to the wall and/or the floor.

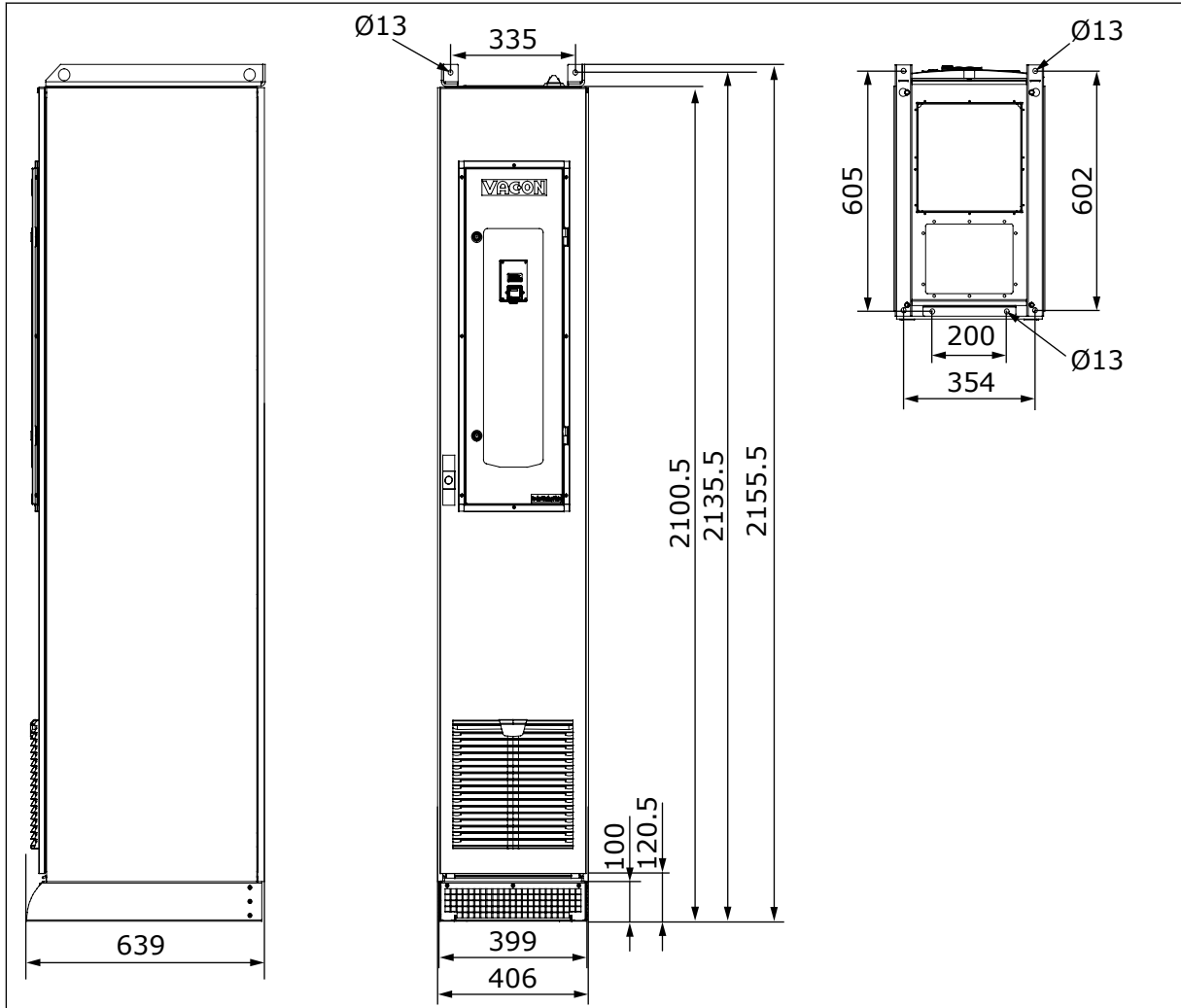

Fig. 3: The dimensions of the default cabinet, MR8, [mm]

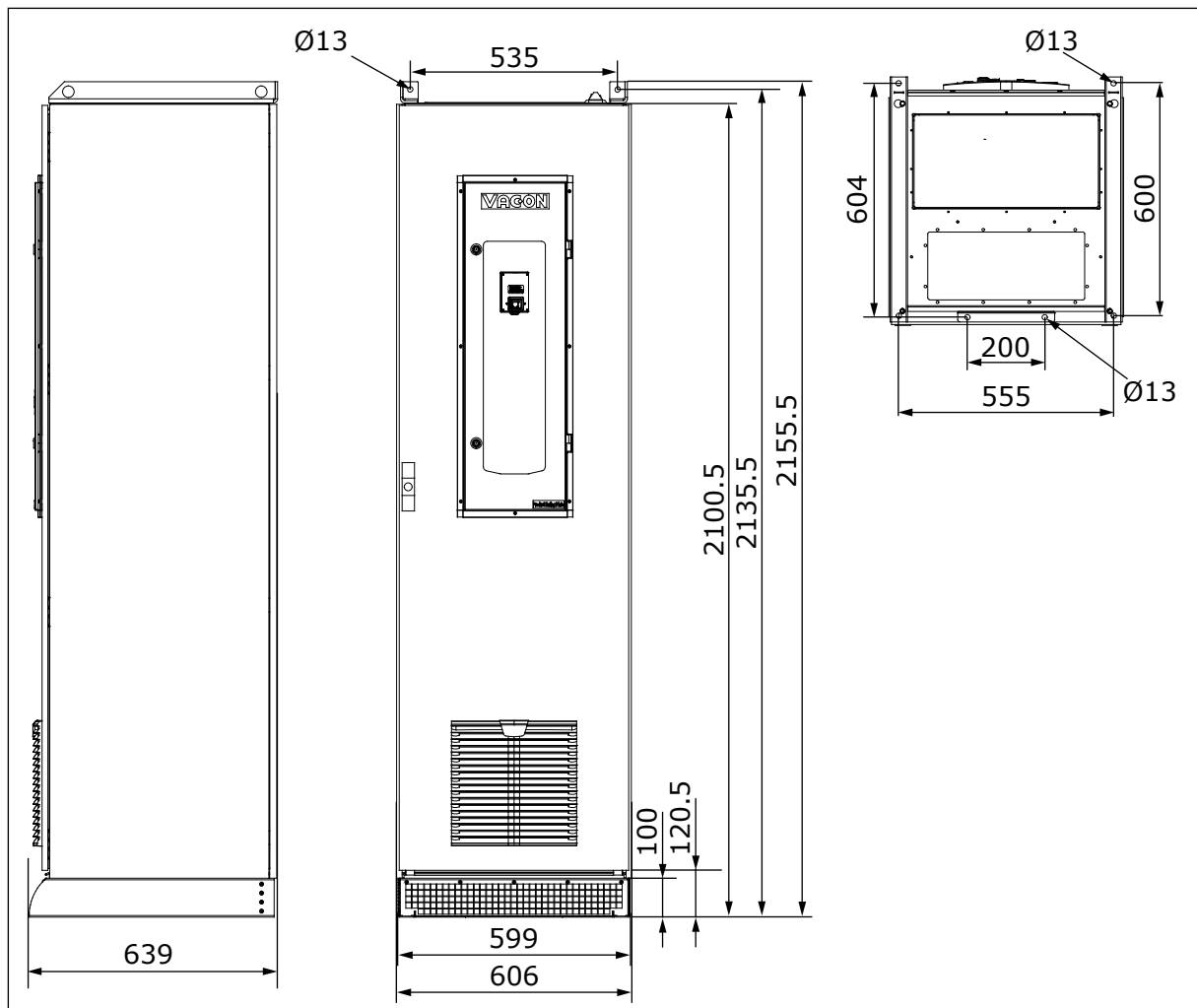

Fig. 4: The dimensions of the default cabinet, MR9 and MR10, [mm]

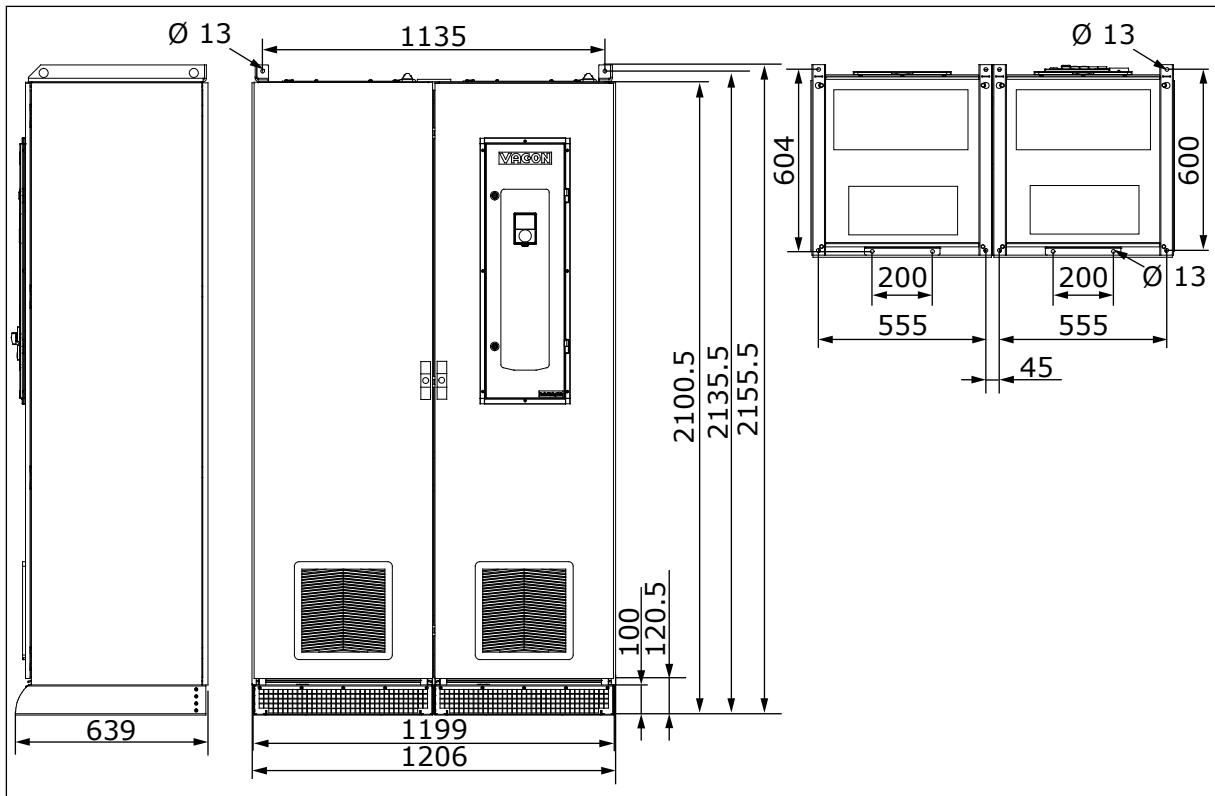

Fig. 5: The dimensions of the default cabinet, MR12, [mm]

4.2 DIMENSIONS OF THE CABINET, NAM

Install the AC drive in a vertical position on level ground. Attach the drive with screws to the wall and/or the floor.

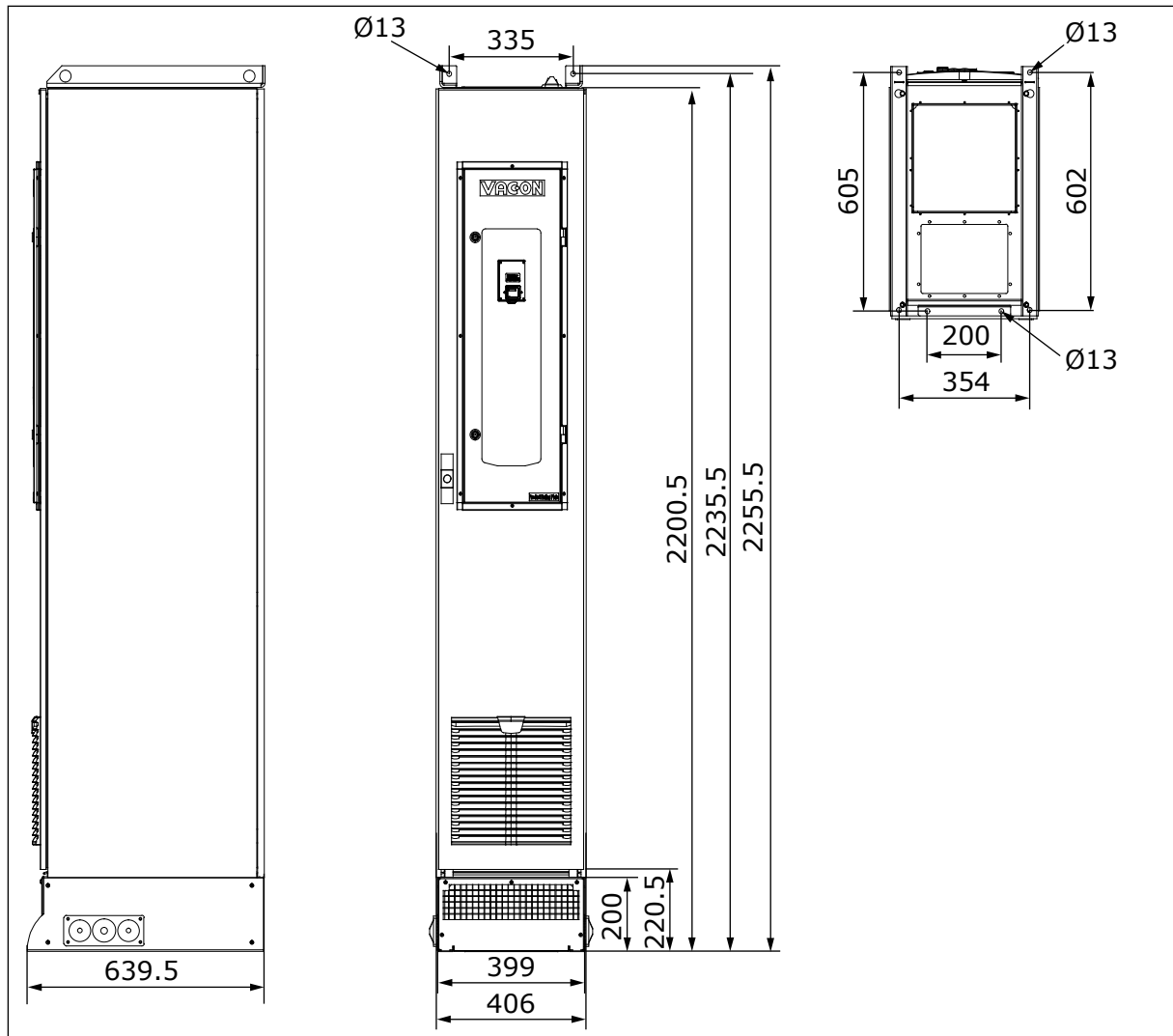

Fig. 6: The dimensions of the default cabinet, MR8, [mm]

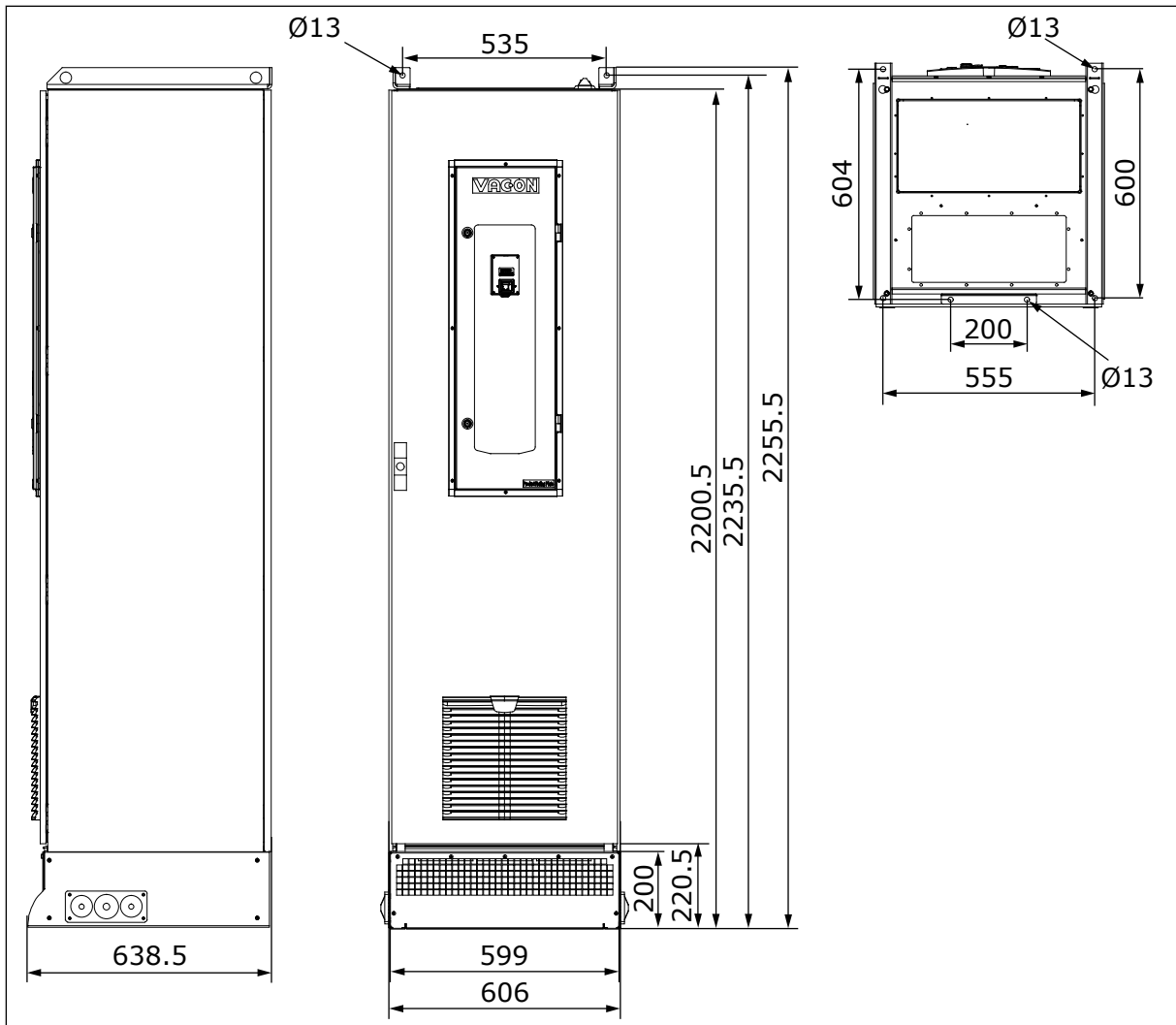

Fig. 7: The dimensions of the default cabinet, MR9 and MR10, [mm]

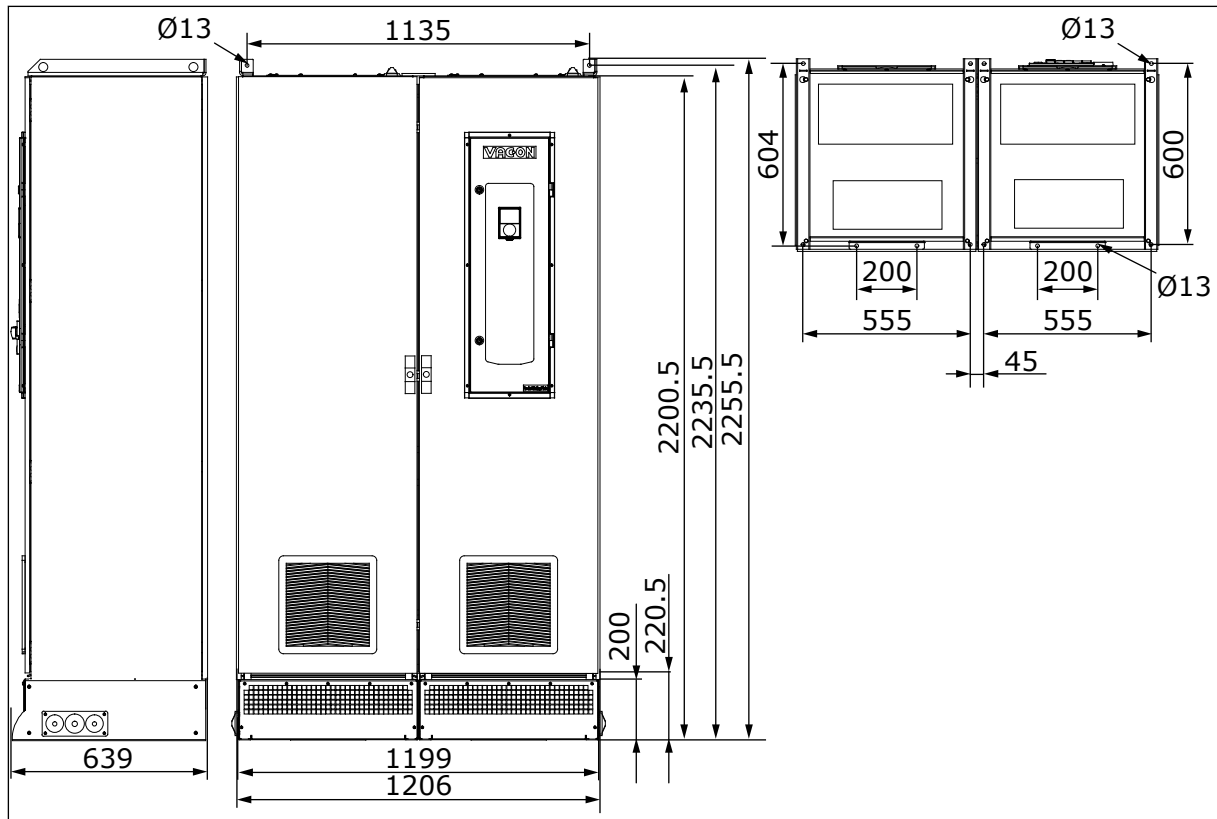

Fig. 8: The dimensions of the default cabinet, MR12, [mm]

4.3 THE OPTIONS

Table 5: The options and their codes

Group	Name	Code
Auxiliary equipment	Motor heater control	+CAMH
	Cabinet heater	+CACH
	Cabinet light	+CACL
Cabinet power supply for accessories	Auxiliary voltage transformer	+CAPT
	24 VDC power supply	+CAPD
	AC customer socket	+CAPS
Door-mounted options	Signal lights and reset button	+CDLP
Control terminals	Extended I/O terminals	+CTID
	Auxiliary AC supply terminals	+CAPU
Protection devices	STO with emergency stop push button on door	+CPS0
	SS1 with emergency stop push button on door	+CPS1
	Emergency switch off	+CPSB
	Insulation monitoring	+CPIF
Input devices	AC fuses and fuse switch	+CIFD
	Input contactor	+CICO *
Dynamic braking	Brake chopper	+DBIN
Output filters	Common mode filter	+POCM
	du/dt filter	+PODU
Cabling options	Input cabling from top	+CHIT
	Output cabling from top	+CHOT
	Cabling from top	+CHCT
Base plinth options	Base plinth 200 mm	+CHPH
Cooling options	Back channel cooling	+CHCB
Enclosure	IP 54	+IP54
Special construction	Marine construction	+CCMA *
Approvals	ULC listed	+CCUL

* = These options are not available for the NAM variation.

+CAMH: MOTOR HEATER CONTROL

With this option, you can control the supply for the motor anti-condensation heater. The external supply is connected to terminals -XD1.1 that are located in the lower part of the cabinet. When the drive is not in Run state, the control relay +QAM changes the external supply to the output terminals (-XDN). When the drive is in Run state, the control relay disconnects the external supply to the motor heater. To disable the function, open the MCB -FCN.

The requirements: +CAPU Auxiliary AC supply terminals

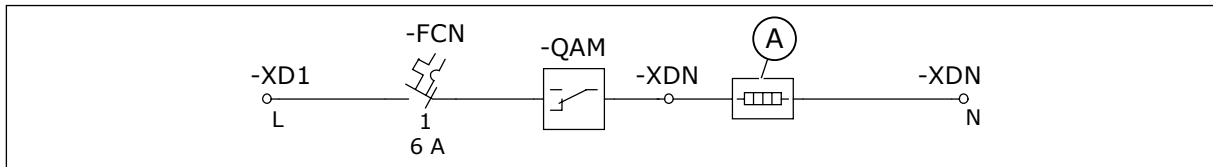

Fig. 9: The motor heater control

- A. The heater element, not included in the delivery

+CACH: CABINET HEATER

This option increases the inside temperature of the cabinet above the ambient temperature, and thus prevents condensation in the cabinet. The external supply is connected to terminals -XD1.1. The heater element is of a self-regulating type. When the drive is not in Run state, the control relay +QAM changes the supply to the output terminals (-XD4). When the drive is in Run state, the control relay disconnects the supply to the cabinet heater. To disable the function, open the MCB -FCE.

The requirements: +CAPU Auxiliary AC supply terminals

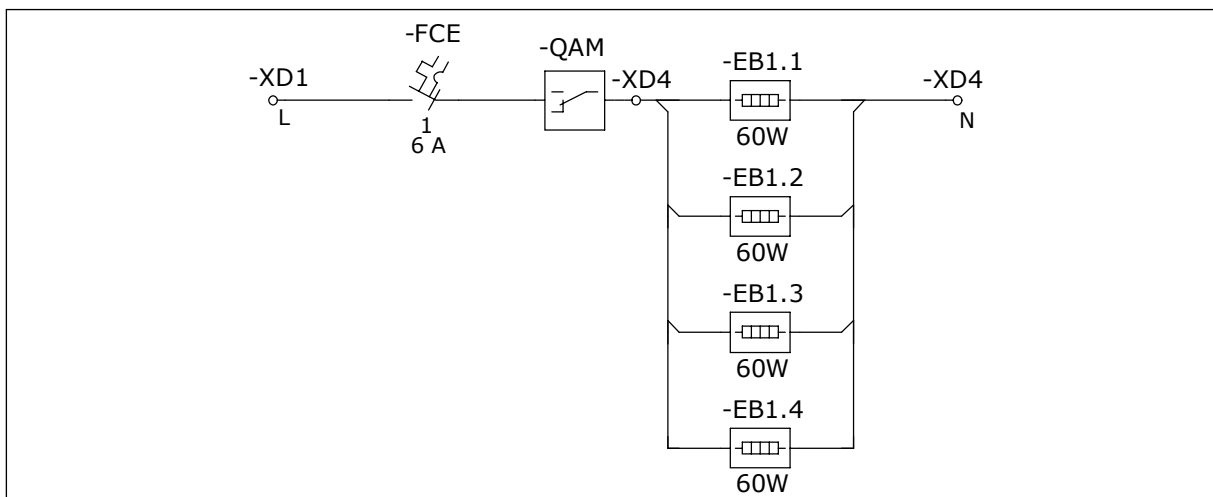

Fig. 10: The cabinet heater

+CACL: CABINET LIGHT

With this option the control compartment will have a light as default by an internal auxiliary transformer or as an option by an external auxiliary voltage supply connected to -XD1.1.

The requirements: +CAPU Auxiliary AC supply terminals or +CAPT Auxiliary voltage transformer

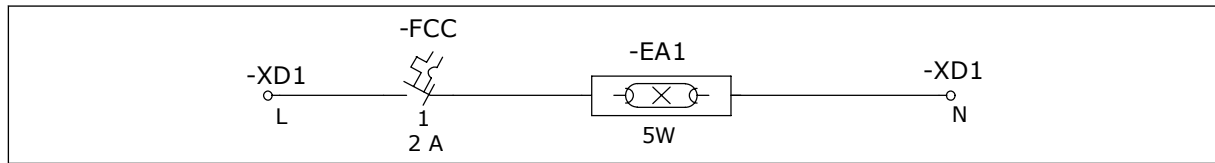

Fig. 11: The cabinet light

+CAPT: AUXILIARY VOLTAGE TRANSFORMER

This option provides the supply of auxiliary voltage for other options. The supply for the auxiliary transformer is taken from mains. If you use the option AC fuses and fuse switch (+CIFD), the supply for the auxiliary voltage transformer is taken from between the drive and the fuse switch. This means that the control voltage is disconnected with the main switch.

The requirements: Not +CAPU Auxiliary AC supply terminals

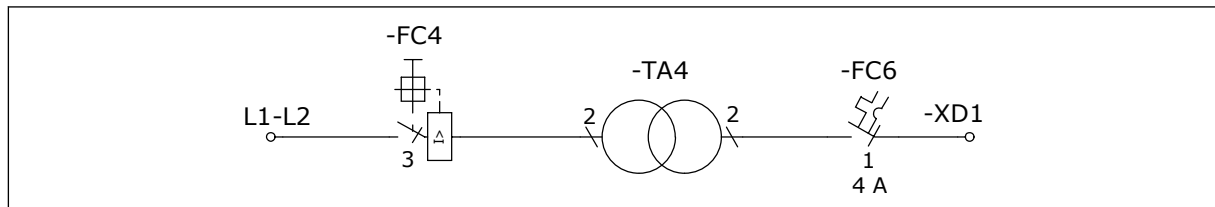

Fig. 12: The auxiliary voltage transformer

+CAPD: 24 VDC POWER SUPPLY

This option provides a backup supply for the control unit of the drive. Use it also for other auxiliary options for which a 24 VDC supply is necessary.

The requirements: +CAPU Auxiliary AC supply terminals or +CAPT Auxiliary voltage transformer. The backup supply for the control unit requires +CAPU Auxiliary AC supply terminals.

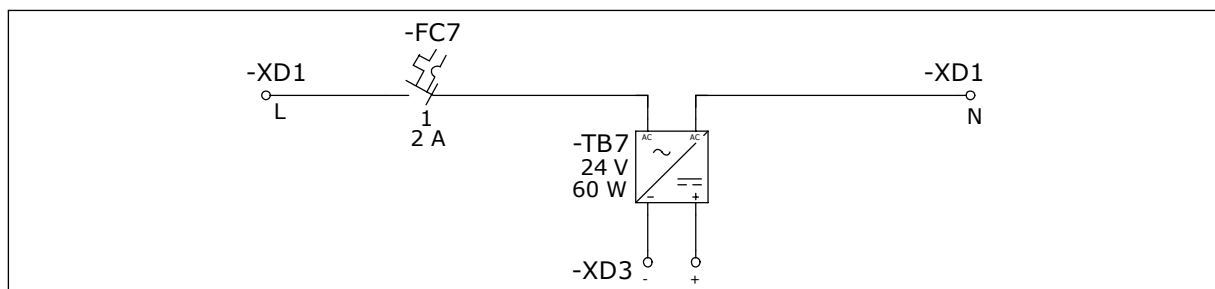

Fig. 13: The 24 VDC power supply

+CAPS: AC CUSTOMER SOCKET

The socket provides a power supply for your measurement equipment, tools or computer. The default voltage is 230 VAC, and 115 VAC in the North American regional variant. The maximum output power with 230 VAC is 450 VA and with 115 VAC it is 230 VA when an external supply (+CAPU) is used, and 180 VA when a transformer supply (+CAPT) is used.

The requirements: +CAPU Auxiliary AC supply terminals or +CAPT Auxiliary voltage transformer

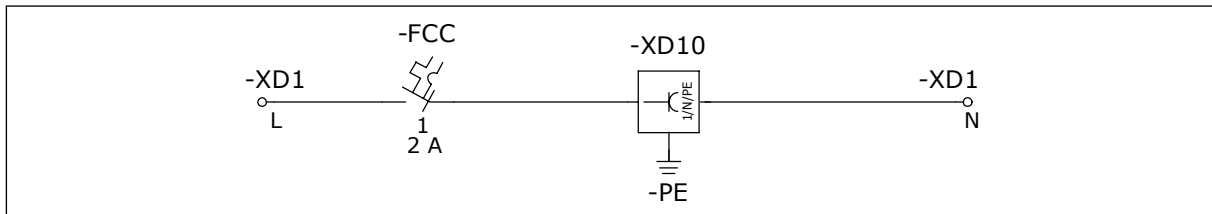

Fig. 14: The AC customer socket

+CDLP: SIGNAL LIGHTS AND RESET BUTTON

This option includes signal lights on the control compartment door for Ready, Run and Fault states of the AC drive. The door also has a button for the reset function of the AC drive. The Ready signal light is not available if you use the option board OPT-F4.

The requirements:

- +CAPD 24 VDC power supply
- +CAPU Auxiliary AC supply terminals or +CAPT Auxiliary voltage transformer

+CTID: EXTENDED I/O TERMINALS

The option includes 20 control terminals (-XDW) in the control compartment for your own free use.

No requirements.

+CAPU: AUXILIARY AC SUPPLY TERMINALS

This option provides terminals -XD1.1 for an external voltage supply. The external supply must be short-circuit protected. The power of this supply depends on other selected cabinet options.

The requirements: Not +CAPT Auxiliary voltage transformer.



WARNING!

The main switch does not disconnect the external voltage supply. Before you touch the components of the control compartment, disconnect the external voltage supply. The voltage can be very dangerous.

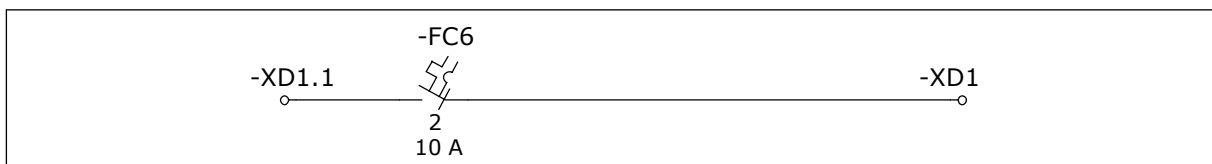

Fig. 15: The auxiliary AC supply terminals

+CPS0: STO WITH EMERGENCY STOP PUSH BUTTON ON DOOR

This option provides the STO (Safe Torque Off) function with the OPT-BJ option board and an emergency stop push button on the door of the control compartment. The STO Channel 1 and

STO Channel 2 are wired to the emergency stop push button. The STO function corresponds to an emergency stop category 0. See the user manual of the OPT-BJ option board for the regulations and the certified safety functions.

The requirements:

- The option board OPT-BJ
- +CAPD 24 VDC power supply
- +CAPU Auxiliary AC supply terminals or +CAPT Auxiliary voltage transformer

+CPS1: SS1 WITH EMERGENCY STOP PUSH BUTTON ON DOOR

This option provides the SS1 (Safe Stop 1) function with the OPT-BJ option board, a safety relay and an emergency stop push button on the control compartment door. Pushing the emergency stop push button activates the motor deceleration and makes the motor stop in the set deceleration ramp time. The STO Channel 1 and STO Channel 2 are wired to the safety relay that activates the STO function after the set delay. See the user manual of the OPT-BJ option board and the safety relay for the regulations and the certified safety functions.

The requirements:

- The option board OPT-BJ
- +CAPD 24 VDC power supply
- +CAPU Auxiliary AC supply terminals or +CAPT Auxiliary voltage transformer



CAUTION!

The delay of the safety relay is process/machine-dependent. The designer and the user of your system are responsible for understanding and setting the delay of the safety relay. An incorrect delay can cause damage to the equipment.

+CPSB: EMERGENCY SWITCH OFF

The Emergency switch off function uses an input contactor to disconnect the drive from mains. Pushing the emergency stop push button on the control compartment door opens the control circuit of the input contactor.

The requirements:

- +CICO Input contactor
- +CAPU Auxiliary AC supply terminals or +CAPT Auxiliary voltage transformer

+CPIF: INSULATION MONITORING

With this option it is possible to monitor the insulation level in an IT supply network with an insulation monitor in the control compartment. The insulation monitor supervises the supply and the insulation faults in the output network.

The requirements:

- +CAPD 24 VDC power supply
- +CAPU Auxiliary AC supply terminals or +CAPT Auxiliary voltage transformer

+CICO: INPUT CONTACTOR

This option makes it possible for you to connect or disconnect the drive from mains. To do it, use a control switch on the control compartment door, or connect an external switch to terminals -XDO. To connect the external switch, refer to the electrical drawings.

The option includes the fuse switch (+CIFD) for safety reasons.

The requirements: +CAPU Auxiliary AC supply terminals or +CAPT Auxiliary voltage transformer

+CIFD: AC FUSES AND FUSE SWITCH

When you have this option, you can isolate the drive safely from the mains with a fuse switch that is located directly below the power unit.

+DBIN: BRAKE CHOPPER

The power unit has a dynamic brake chopper. The external brake resistor is connected directly to the brake resistor terminals of the power unit, see chapter 5.4.1 *Installing the cables*.

+POCM: COMMON MODE FILTER

The option includes an output filter that decreases the common mode voltage. The filter is connected between the motor cable terminals of the power unit and the motor cable terminals of the drive. The filter does not have an effect on the connection of the external motor cables.

+PODU: DU/DT FILTER

The option includes an output filter that increases the rise time of the voltage pulse, and thus decreases the voltage stress on the motor winding insulation. The filter is connected between the motor cable terminals of the power unit and the motor cable terminals of the drive. The filter does not have an effect on the connection of the external motor cables.

4.4 INSTALLATION OF THE CABINET

To attach the cabinet to the floor, there are 3 alternatives.

- Use the 4 fixing points at the bottom of the cabinet.
- Use the 2 fixing points at the front bottom and the 2 fixing points at the rear top of the cabinet.
- Use the 2 fixing points in the fixing bracket and the 2 fixing points at the front bottom of the cabinet. To use the fixing bracket, first attach it to the floor. Slide the edge of the cabinet plinth under the fixing bracket. Then attach the 2 fixing points at the front bottom.

**NOTE!**

If you have multiple cabinet sections (for example with MR12 or top cabling sections), these steps must be done for each section.

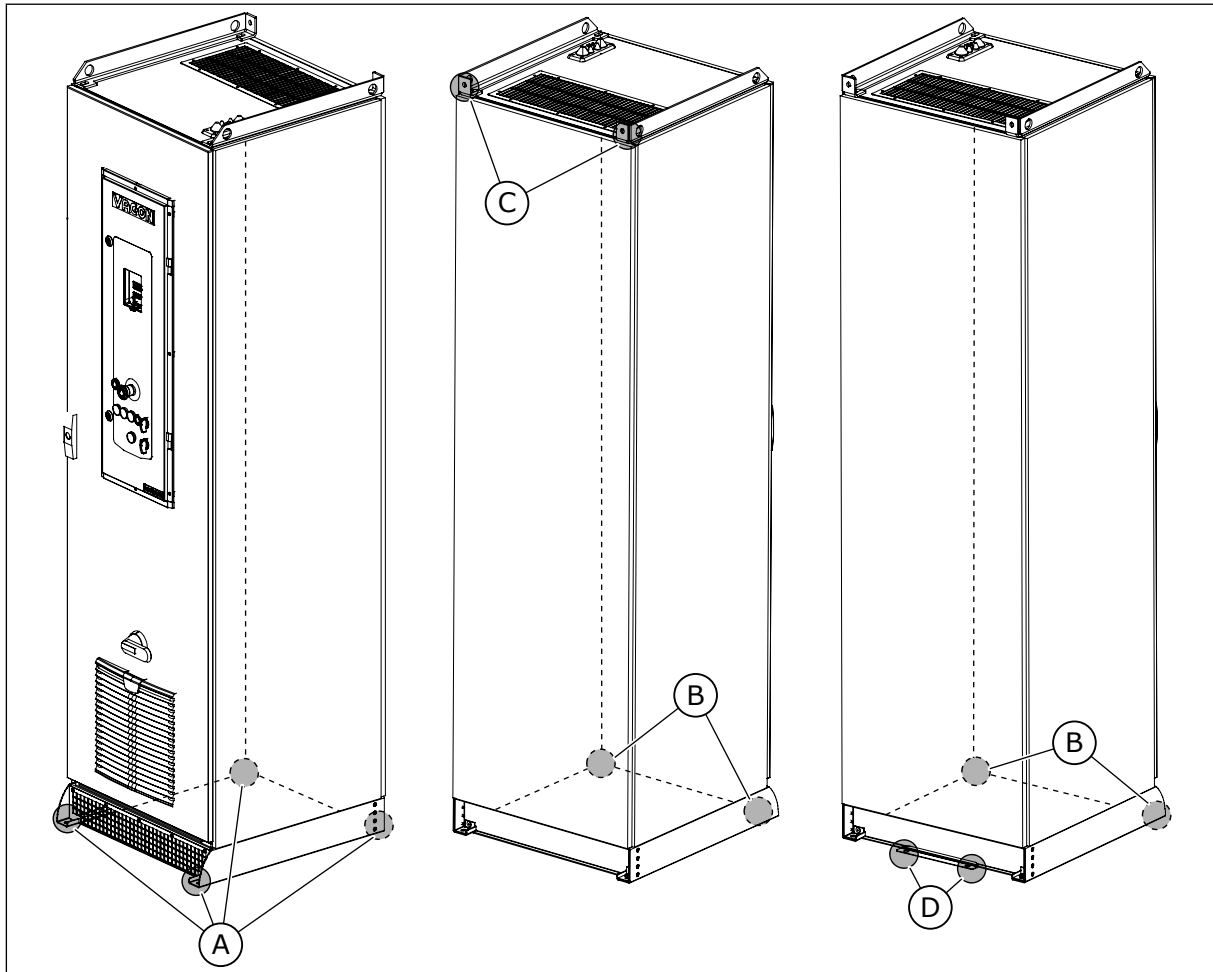

Fig. 16: The fixing points of the cabinet

- | | |
|--------------------------------------------|----------------------------------------------|
| A. The 4 fixing points at the bottom | C. The 2 fixing points at the rear top |
| B. The 2 fixing points at the front bottom | D. The 2 fixing points in the fixing bracket |

4.5 COOLING AND FREE SPACE AROUND THE AC DRIVE

The AC drive produces heat in operation. The fan circulates air and decreases the temperature of the drive. Make sure that there is sufficiently free space around the drive.

Some free space in front of the drive is also necessary for maintenance. You must also have 80 cm of free space in front of the cabinet to be able to open the cabinet door. When you have 2 or more drives, you can install them side by side.

Make sure that the temperature of the cooling air does not become higher than the maximum ambient operating temperature or lower than the minimum ambient operating temperature of the drive.

The air must move freely and efficiently through the cabinet and the drive. There must be a minimum of 30 cm of space above the cabinet without obstacles that can stop the airflow. Make sure that the hot air goes out of the cabinet and does not come back into the cabinet.

The power loss of the AC drive can change significantly, when the load, the output frequency or the switching frequency changes. It is useful to know the power loss, when you plan the cooling equipment in an electrical room. Use this formula to calculate the approximate power loss of the drive in nominal conditions.

$$P_{\text{loss}} [\text{kW}] = P_{\text{mot}} [\text{kW}] \times 0.025$$

It is possible that there will be an increase of 0-0.5% in the power loss when you have options in the cabinet.

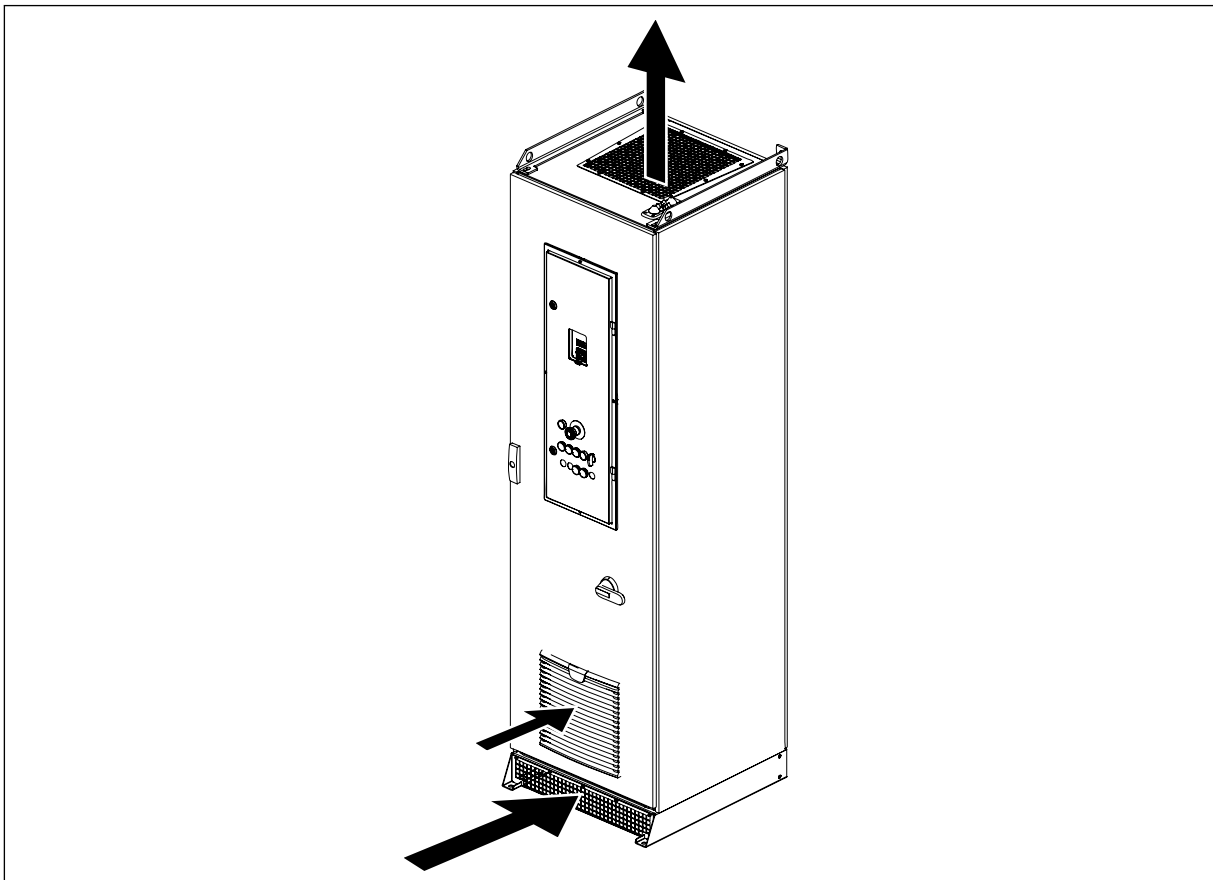

Fig. 17: The circulation of cooling air

Table 6: The necessary quantity of cooling air

Frame	The quantity of cooling air [m ³ /h]
MR8	330
MR9	620
MR10	1400
MR12	2 x 1400

4.6 THE OPTIONAL BACK CHANNEL COOLING

You can also use the back channel cooling option (+CHCB) for the cooling of the AC drive.

USING THE BACK CHANNEL FOR COOLING

- 1 Make an opening in the wall behind the cabinet.
- 2 To prevent condensation in the cabinet, connect the supply cable of the cabinet heater to the correct terminals in the control compartment.
- 3 Attach the duct adapter flanges to the cabinet with screws.
- 4 Do not install the cabinet in an airtight space. Approximately 5-10% of the intake air must come from the front.

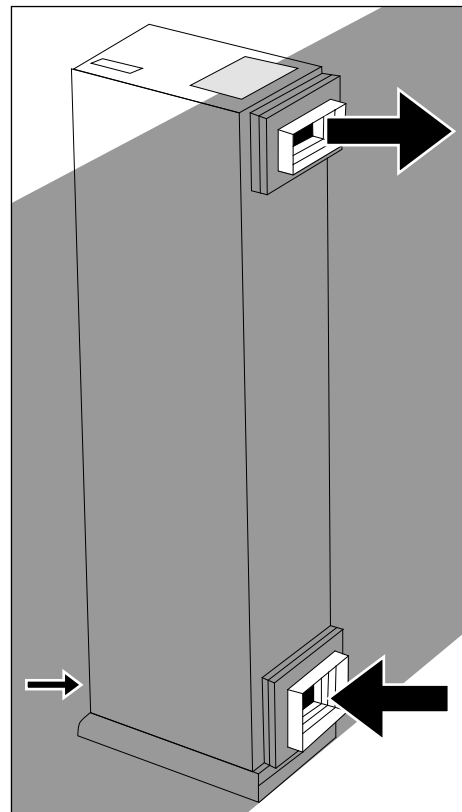

- 5 Move the cabinet adjacent to the wall.
- 6 Make sure that you seal the openings correctly.

**CAUTION!**

If you use long air ducts in addition to the duct adapter flanges, use a duct fan or equivalent to prevent back pressure. Back pressure must be prevented because it decreases the performance of the drive.

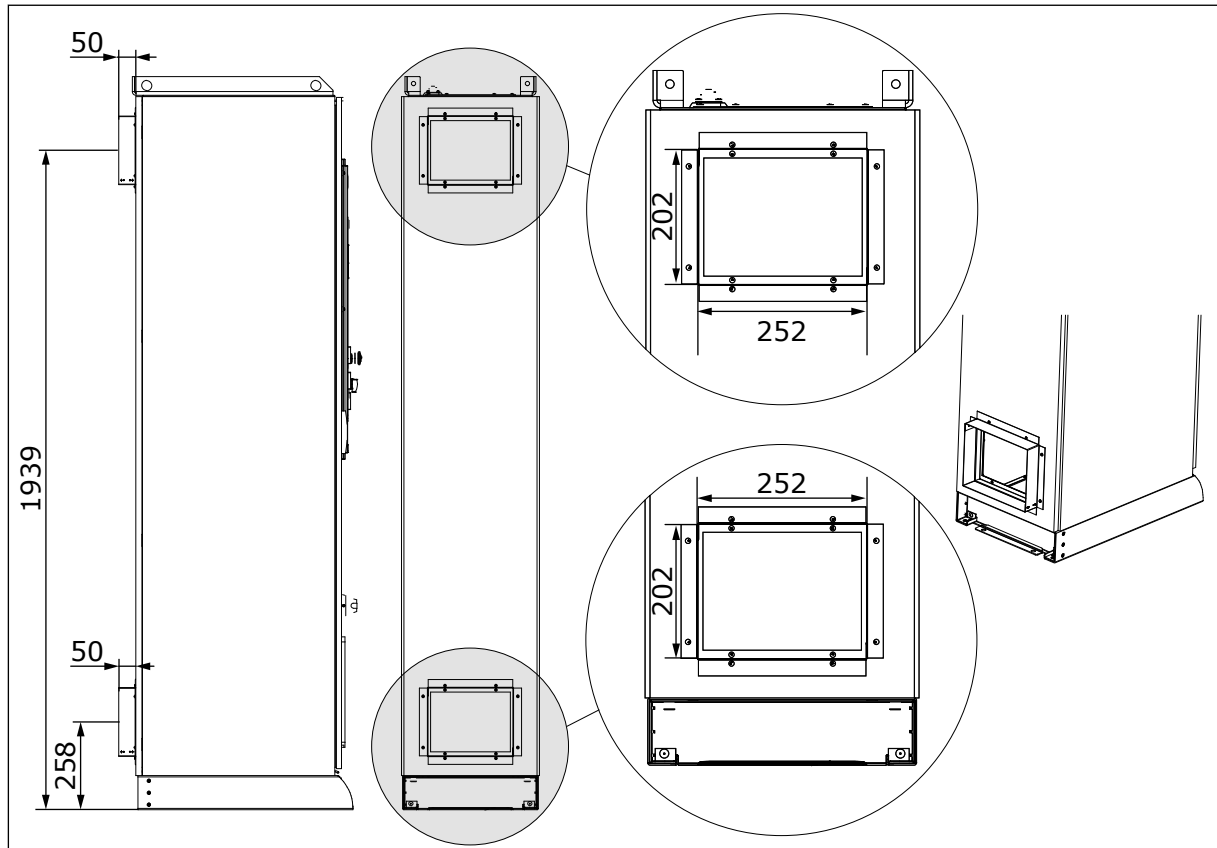

Fig. 18: Dimensions for the back channel cooling, MR8

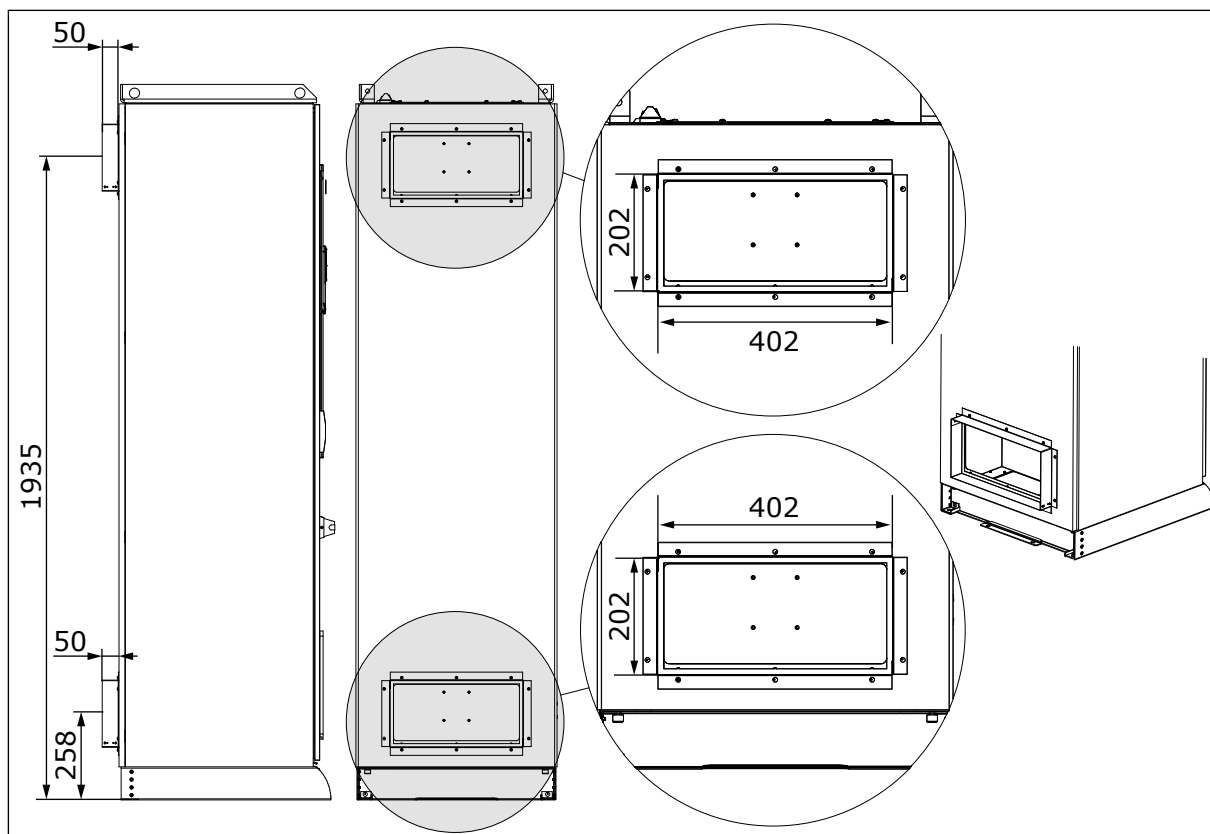

Fig. 19: Dimensions for the back channel cooling, MR9 and MR12

5 POWER CABLING

5.1 CABLE DIMENSIONING AND SELECTION

5.1.1 CABLE AND FUSE SIZES, IEC

We recommend the fuse type gG/gL (IEC 60269-1) for mains fuses (-F1). Use only fuses that have a sufficient voltage rating according to the mains voltage. Do not use larger fuses than what is recommended in *Table 7*. The fuses are selected for short circuit protection only.



NOTE!

The overcurrent protection of parallel cables must be done with separate fuses.

Make sure that the operation time of the fuse is less than 0.4 seconds. The operation time agrees with the fuse type and the impedance of the supply circuit.

The table also shows the typical symmetrically shielded copper and aluminum types of the cables that can be used with the AC drive.



NOTE!

The mains cable and fuse sizes are valid up to a cable length of 100 m, with mains $I_K = 20$ kA.

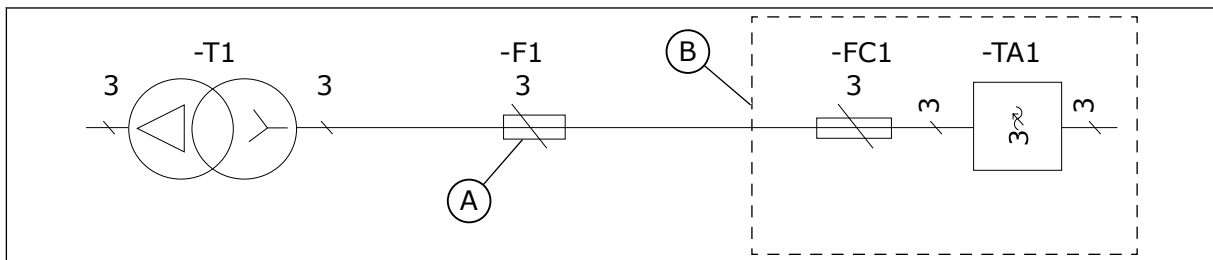

Fig. 20: The location of the fuses, MR8-MR10

A. The mains fuses

B. The cabinet

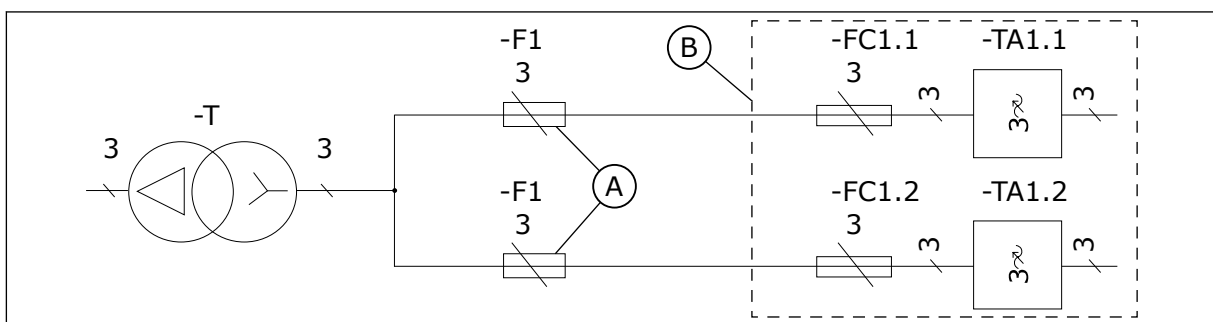

Fig. 21: The location of the fuses, MR12

A. The mains fuses

B. The cabinet

The drive should be protected with fast acting aR-type fuses (-FC1) (see *Table 9*, *Table 10*, *Table 11* and *Table 12*). Do not use other fuses than these. These fuses are included in the delivery.

The dimensions of the cables agree with the requirements of the standards EN 60204-1 and IEC 60364-5-52: 2001.

- The cables are PVC-isolated.
- The maximum ambient temperature is +30 °C.
- The maximum temperature of the cable surface is +70 °C.
- The maximum number of parallel cables on a ladder type tray is 9 side by side.

In other conditions, when you select the dimensions of the cables, refer to local safety regulations, the input voltage and the load current of the drive.

Table 7: The recommended cables and fuses in 380-500 V (IEC)

Frame	Type	IL [A]	Mains fuse (gG/gL) [A]	Mains and motor cable (Cu/Al) [mm ²]	Mains and motor cable terminals, bolt size	Grounding terminal, bolt size
MR8	0140 5	140	160	{3x70+35} (Cu) {3x95+29} (Al)	M8	M8
	0170 5	170	200	{3x95+50} (Cu) {3x150+41} (Al)	M8	M8
	0205 5	205	250	{3x120+70} (Cu) {3x185+57} (Al)	M8	M8
MR9	0261 5	261	315	{3x185+95} (Cu) 2x{3x120+41} (Al)	M10	M8
	0310 5	310	355	2x{3x95+50} (Cu) 2x{3x120+41} (Al)	M10	M8
MR10	0385 5	385	400	2x{3x120+70} (Cu) 2x{3x185+57} (Al)	M12	M8
	0460 5	460	500	2x{3x150+70} (Cu) 2x{3x240+72} (Al)	M12	M8
	0520 5	520	630	2x{3x185+95} (Cu) 3x{3x150+41} (Al)	M12	M8
	0590 5	590	630	2x{3x240+120} (Cu) 3x{3x185+57} (Al)	M12	M8
MR12	0650 5	650	2 x 355	4x{3x95+50} (Cu) 4x{3x120+41} (Al)	M12	M8
	0730 5	730	2 x 400	4x{3x95+50} (Cu) 4x{3x150+41} (Al)	M12	M8
	0820 5	820	2 x 500	4x{3x120+70} (Cu) 4x{3x185+57} (Al)	M12	M8
	0920 5	920	2 x 500	4x{3x150+70} (Cu) 4x{3x240+72} (Al)	M12	M8
	1040 5	1040	2 x 630	4x{3x185+95} (Cu) 6x{3x150+41} (Al)	M12	M8
	1180 5	1180	2 x 630	4x{3x240+120} (Cu) 6x{3x185+57} (Al)	M12	M8

Table 8: The recommended cables and fuses in 525-690 V (IEC)

Frame	Type	IL [A]	Mains fuse (gG/gL) [A]	Mains and motor cable (Cu/Al) [mm ²]	Mains and motor cable terminals, bolt size	Grounding terminal, bolt size
MR8	0080 7	80	100	3x35+16 (Cu) 3x50+21 (Al)	M8	M8
	0100 7	100	125	3x50+25 (Cu) 3x70+21 (Al)	M8	M8
	0125 7	125	160	3x70+35 (Cu) 3x95+29 (Al)	M8	M8
MR9	0144 7	144	160	3x70+35 (Cu) 3x120+41 (Al)	M10	M8
	0170 7	170	200	3x95+50 (Cu) 3x150+41 (Al)	M10	M8
	0208 7	208	250	3x120+70 (Cu) 3x185+57 (Al)	M10	M8
MR10	0261 7	261	315	3x185+95 (Cu) 2x(3x95+29) (Al)	M12	M8
	0325 7	325	355	3x240+120 (Cu) 2x(3x120+41) (Al)	M12	M8
	0385 7	385	400	2x(3x120+70) (Cu) 2x(3x185+57) (Al)	M12	M8
	0416 7	416	450	2x(3x120+70) (Cu) 2x(3x185+57) (Al)	M12	M8
MR12	0460 7	460	2 x 315	2x(3x150+70) (Cu) 2x(3x240+72) (Al)	M12	M8
	0520 7	520	2 x 315	2x(3x185+95) (Cu) 4x(3x95+29) (Al)	M12	M8
	0590 7	590	2 x 315	4x(3x70+35) (Cu) 4x(3x120+41) (Al)	M12	M8
	0650 7	650	2 x 355	4x(3x95+50) (Cu) 4x(3x150+41) (Al)	M12	M8
	0730 7	730	2 x 400	4x(3x120+70) (Cu) 4x(3x150+41) (Al)	M12	M8
	0820 7	820	2 x 425	4x(3x120+70) (Cu) 4x(3x185+57) (Al)	M12	M8

Table 9: Drive fuses, 380-500 V, Mersen (IEC)

Frame	Type	IL [A]	Catalogue number of the fuse	Fuse rating [A]	Number of fuses needed	Fuse size	Minimum prospective short circuit current [A]
MR8	0140 5	140	NH1UD69V250PV	250	3	1	1400
	0170 5	170	NH1UD69V350PV	350	3	1	2400
	0205 5	205	NH1UD69V400PV	400	3	1	2800
MR9	0261 5	261	NH2UD69V500PV	500	3	2	3300
	0310 5	310	NH2UD69V630PV	630	3	2	5000
MR10	0385 5	385	NH2UD69V700PV	700	3	2	5700
	0460 5	460	NH3UD69V900PV	900	3	3	7000
	0520 5	520	NH3UD69V1000PV	1000	3	3	8600
	0590 5	590	PC73UD90V10CPA	1000	3	3	13000
MR12	0650 5	650	NH2UD69V630PV	630	6	2	5000
	0730 5	730	NH2UD69V700PV	700	6	2	5700
	0820 5	820	NH3UD69V900PV	900	6	3	7000
	0920 5	920	NH3UD69V1000PV	1000	6	3	8600
	1040 5	1040	NH3UD69V1000PV	1000	6	3	8600
	1180 5	1180	PC73UD90V10CPA	1000	6	3	13000

Table 10: Drive fuses, 525-690 V, Mersen (IEC)

Frame	Type	IL [A]	Catalogue number of the fuse	Fuse rating [A]	Number of fuses needed	Fuse size	Minimum prospective short circuit current [A]
MR8	0080 7	80	NH1UD69V125PV	125	3	1	500
	0100 7	100	NH1UD69V160PV	160	3	1	700
	0125 7	125	NH1UD69V200PV	200	3	1	1000
MR9	0144 7	144	NH1UD69V315PV	315	3	1	2000
	0170 7	170	NH1UD69V350PV	350	3	1	2400
	0208 7	208	NH1UD69V400PV	400	3	1	2800
MR10	0261 7	261	NH2UD69V400PV	400	3	2	2800
	0325 7	325	NH2UD69V500PV	500	3	2	3300
	0385 7	385	NH2UD69V630PV	630	3	2	5000
	0416 7	416	NH3UD69V900PV	900	3	3	7100
MR12	0460 7	460	NH2UD69V400PV	400	6	2	2400
	0520 7	520	NH2UD69V450PV	450	6	2	2800
	0590 7	590	NH2UD69V500PV	500	6	2	3300
	0650 7	650	NH2UD69V550PV	550	6	2	4000
	0750 7	750	NH2UD69V630PV	630	6	2	5000
	0820 7	820	NH3UD69V900PV	900	6	3	7100

Table 11: Drive fuses, 380-500 V, Bussmann (IEC)

Frame	Type	IL [A]	Catalogue number of the fuse	Fuse rating [A]	Number of fuses needed	Fuse size	Minimum prospective short circuit current [A]
MR8	0140 5	140	170M3817D	315	3	1	1700
	0170 5	170	170M3818D	350	3	1	1950
	0205 5	205	170M3819D	400	3	1	2400
MR9	0261 5	261	170M5810D	500	3	2	2800
	0310 5	310	170M5812D	630	3	2	4000
MR10	0385 5	385	170M5814D	800	3	2	5750
	0460 5	460	170M6814D	1000	3	3	7500
	0520 5	520	170M6892D	1100	3	3	8500
	0590 5	590	170M8554D	1250	3	3	10500
MR12	0650 5	650	170M5814D	800	6	2	5750
	0730 5	730	170M5814D	800	6	2	5750
	0820 5	820	170M6813D	900	6	3	6000
	0920 5	920	170M6814D	1000	6	3	7500
	1040 5	1040	170M6892D	1100	6	3	8500
	1180 5	1180	170M8554D	1250	6	3	10500

Table 12: Drive fuses, 525-690 V, Bussmann (IEC)

Frame	Type	IL [A]	Catalogue number of the fuse	Fuse rating [A]	Number of fuses needed	Fuse size	Minimum prospective short circuit current [A]
MR8	0080 7	80	170M3814D	160	3	1	650
	0100 7	100	170M3815D	200	3	1	950
	0125 7	125	170M3816D	250	3	1	1300
MR9	0144 7	144	170M3817D	315	3	1	1700
	0170 7	170	170M3819D	400	3	1	2400
	0208 7	208	170M4863D	450	3	1	2800
MR10	0261 7	261	170M5811D	550	3	2	3400
	0325 7	325	170M5813D	700	3	2	4800
	0385 7	385	170M5814D	800	3	2	5750
	0416 7	416	170M6814D	1000	3	3	7500
MR12	0460 7	460	170M5811D	550	6	2	3400
	0520 7	520	170M5812D	630	6	2	4000
	0590 7	590	170M5813D	700	6	2	4800
	0650 7	650	170M5813D	700	6	2	4800
	0750 7	750	170M5814D	800	6	2	5750
	0820 7	820	170M6813D	900	6	3	6000

5.1.2 CABLE AND FUSE SIZES, NAM

Fuses that are contained in the product (-FC1) are suitable for both short circuit and branch circuit protection (see *Table 15* and *Table 16*). Do not use other fuses than these.



NOTE!

The overcurrent protection of parallel cables must be done with separate fuses.

Make sure that the operation time of the fuse is less than 0.4 seconds. The operation time agrees with the fuse type and the impedance of the supply circuit.

The table also shows the typical symmetrically shielded copper and aluminum types of the cables that can be used with the AC drive.



NOTE!

The mains cable and fuse sizes are valid up to a cable length of 100 m, with mains $I_k = 20$ kA.

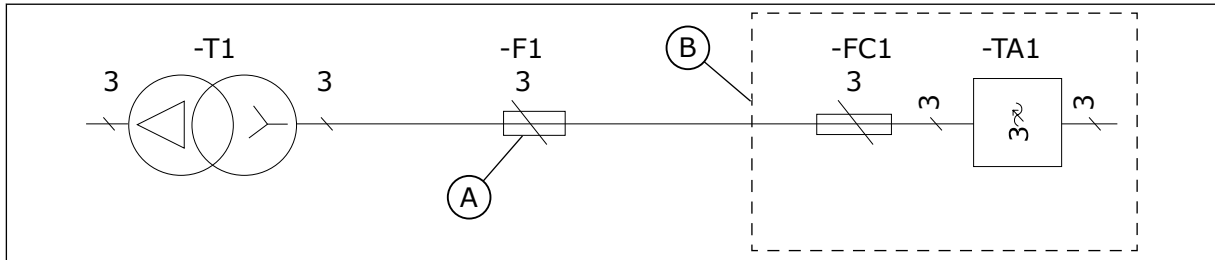

Fig. 22: The location of the fuses, MR8-MR10

A. The mains fuses

B. The cabinet

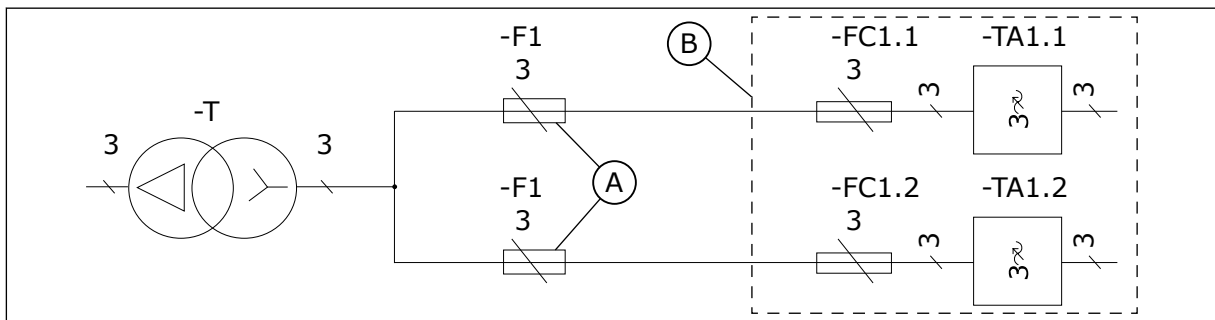

Fig. 23: The location of the fuses, MR12

A. The mains fuses

B. The cabinet

The cable dimensioning in *Table 13* and *Table 14* is in accordance with UL61800-5-1 and the National Electric Code per table 310.15(B)(16). The values of the tables were calculated using correction factors for a 40°C ambient operating temperature, and using AC drive cables with a minimum insulation rating of 90°C. Refer to local or municipal regulations for more sizing requirements.

The UL approval is valid for input voltage up to 600 V.

Table 13: The recommended cables and terminal lugs in 380-500 V (NAM)

Frame	Type	IL (A)	Mains and motor cable (Cu) [AWG/kcmil]	Mains and motor cable termination, Panduit terminal part number	Grounding terminal, bolt and lug size
MR8	0140 5	140	[3x2/0+3x10]	LCAX2/0-38-X	P10-56R-L
	0170 5	170	[3x4/0+3x8]	LCAX4/0-38-X	LCAX8-56-L
	0205 5	205	[3x262+3x6]	LCAX250-38-X	LCAX6-56-L
MR9	0261 5	261	2x[3x2/0+3x10]	LCAX2/0-38-X	P10-56R-L
	0310 5	310	2x[3x4/0+3x8]	LCAX4/0-38-X	LCAX8-56-L
MR10	0385 5	385	2x[3x262+3x6]	LCAX250-12-X	LCAX6-56-L
	0460 5	460	2x[3x313+3x6]	LCAX300-12-6	LCAX6-56-L
	0520 5	520	2x[3x373+3x6]	LCAX350-12-6	LCAX6-56-L
	0590 5	590	3x[3x262+3x6]	LCAX250-12-X	LCAX6-56-L
MR12	0650 5	650	4x[3x4/0+3x8]	LCAX4/0-12-X	LCAX8-56-L
	0730 5	730	4x[3x4/0+3x8]	LCAX4/0-12-X	LCAX8-56-L
	0820 5	820	4x[3x262+3x6]	LCAX250-12-X	LCAX6-56-L
	0920 5	920	4x[3x313+3x6]	LCAX300-12-6	LCAX6-56-L
	1040 5	1040	4x[3x373+3x6]	LCAX350-12-6	LCAX6-56-L
	1180 5	1180	6x[3x262+3x6]	LCAX250-12-X	LCAX6-56-L

Table 14: The recommended cables and terminal lugs in 525-690 V (NAM)

Frame	Type	IL (A)	Mains and motor cable (Cu) [AWG/kcmil]	Mains and motor cable termination, Panduit terminal part number	Grounding terminal, bolt and lug size
MR8	0080 7	80	(3x2+3x10)	LCAX2-38-E	P10-56R-L
	0100 7	100	(3x1+3x10)	LCAX1-38-X	P10-56R-L
	0125 7	125	(3x2/0+3x10)	LCAX2/0-38-X	P10-56R-L
MR9	0144 7	144	(3x4/0+3x8)	LCAX4/0-38-X	LCAX8-56-L
	0170 7	170	(3x4/0+3x8)	LCAX4/0-38-X	LCAX8-56-L
	0208 7	208	2x(3x1+3x10)	LCAX1-38-X	P10-56R-L
MR10	0261 7	261	2x(3x2/0+3x10)	LCA2/0-12-X	P10-56R-L
	0325 7	325	2x(3x4/0+3x8)	LCAX4/0-12-X	LCAX8-56-L
	0385 7	385	2x(3x262+3x6)	LCAX250-12-X	LCAX6-56-L
	0416 7	416	2x(3x262+3x6)	LCAX250-12-X	LCAX6-56-L
MR12	0460 7	460	4x(3x1/0+3x10)	LCAX1/0-12-X	P10-56R-L
	0520 7	520	4x(3x2/0+3x10)	LCAX2/0-12-X	P10-56R-L
	0590 7	590	4x(3x4/0+3x8)	LCAX4/0-12-X	LCAX8-56-L
	0650 7	650	4x(3x4/0+3x8)	LCAX4/0-12-X	LCAX8-56-L
	0730 7	730	4x(3x4/0+3x8)	LCAX4/0-12-X	LCAX8-56-L
	0820 7	820	4x(3x262+3x6)	LCAX250-12-X	LCAX6-56-L

Table 15: Drive fuses, 380-500 V, Mersen (NAM)

Frame	Type	IL [A]	Catalogue number of the fuse	Fuse rating [A]	Number of fuses needed	Fuse size	Minimum prospective short circuit current [A]
MR8	0140 5	140	PC30UD69V250TF	250	3	PSC30	1550
	0170 5	170	PC30UD69V315TF	315	3	PSC30	2250
	0205 5	205	PC30UD69V350TF	350	3	PSC30	2550
MR9	0261 5	261	PC30UD69V400TF	400	3	PSC30	3100
	0310 5	310	PC30UD69V550TF	550	3	PSC30	4700
MR10	0385 5	385	PC32UD69V630TF	630	3	PSC32	4700
	0460 5	460	PC32UD69V700TF	700	3	PSC32	5700
	0520 5	520	PC32UD69V900TF	900	3	PSC32	8200
	0590 5	590	PC32UD69V1000TF	1000	3	PSC32	9600
MR12	0650 5	650	PC32UD69V630TF	630	6	PSC32	4700
	0730 5	730	PC32UD69V630TF	630	6	PSC32	4700
	0820 5	820	PC32UD69V700TF	700	6	PSC32	5700
	0920 5	920	PC32UD69V800TF	800	6	PSC32	6800
	1040 5	1040	PC32UD69V900TF	900	6	PSC32	8200
	1180 5	1180	PC32UD69V1000TF	1000	6	PSC32	9600

Table 16: Drive fuses, 525-690 V, Mersen (NAM)

Frame	Type	IL [A]	Catalogue number of the fuse	Fuse rating [A]	Number of fuses needed	Fuse size	Minimum prospective short circuit current [A]
MR8	0080 7	80	PC30UD69V160TF	160	3	PSC30	800
	0100 7	100	PC30UD69V200TF	200	3	PSC30	1200
	0125 7	125	PC30UD69V250TF	250	3	PSC30	1550
MR9	0144 7	144	PC30UD69V315TF	315	3	PSC30	2250
	0170 7	170	PC30UD69V315TF	315	3	PSC30	2250
	0208 7	208	PC30UD69V350TF	350	3	PSC30	2550
MR10	0261 7	261	PC32UD69V450TF	450	3	PSC32	3000
	0325 7	325	PC32UD69V500TF	500	3	PSC32	3400
	0385 7	385	PC32UD69V630TF	630	3	PSC32	4700
	0416 7	416	PC32UD69V700TF	700	3	PSC32	5700
MR12	0460 7	460	PC32UD69V450TF	450	6	PSC32	3000
	0520 7	520	PC32UD69V450TF	450	6	PSC32	3000
	0590 7	590	PC32UD69V500TF	500	6	PSC32	3400
	0650 7	650	PC32UD69V550TF	550	6	PSC32	3900
	0750 7	750	PC32UD69V630TF	630	6	PSC32	4700
	0820 7	820	PC32UD69V700TF	700	6	PSC32	5700

5.2 BRAKE RESISTOR CABLES

Table 17: Brake resistor cables, 380-500 V

Frame	Type	IL [A]	Brake resistor cable (Cu) [mm ²]
MR8	0140 5	140	3x70+35
	0170 5	170	3x95+50
	0205 5	205	3x120+70
MR9	0261 5	261	2x(3x70+35)
	0310 5	310	2x(3x95+50)
MR10	0385 5	385	2x(3x95+50)
	0460 5	460	
	0520 5	520	2x(3x120+70)
	0590 5	590	
MR12	0650 5	650	4x(3x95+50)
	0730 5	730	
	0820 5	820	
	0920 5	920	
	1040 5	1040	4x(3x120+70)
	1180 5	1180	

One of the cable conductors remains unconnected. Use a symmetrically shielded cable, the same type as with the mains and motor cables.



NOTE!

The different Vacon® 100 applications have different functions. For example, the Vacon® 100 FLOW does not have the dynamic braking or the brake resistor functions.

Table 18: Brake resistor cables, 525-690 V

Frame	Type	IL [A]	Brake resistor cable (Cu) [mm ²]
MR8	0080 7	80	3x35+16
	0100 7	100	3x50+25
	0125 7	125	3x70+35
MR9	0144 7	144	3x70+35
	0170 7	170	3x95+50
	0208 7	208	3x120+70
MR10	0261 7	261	2x(3x70+35)
	0325 7	325	
	0385 7	385	2x(3x95+50)
	0416 7	416	
MR12	0460 7	460	4x(3x70+35)
	0520 7	520	
	0590 7	590	
	0650 7	650	
	0750 7	750	4x(3x95+50)
	0820 7	820	

One of the cable conductors remains unconnected. Use a symmetrically shielded cable, the same type as with the mains and motor cables.

**NOTE!**

The different Vacon® 100 applications have different functions. For example, the Vacon® 100 FLOW does not have the dynamic braking or the brake resistor functions.

5.3 PREPARING FOR THE CABLE INSTALLATION

- Before you start, make sure that none of the components of the AC drive is live. Read carefully the warnings in chapter 2 *Safety*.
- Make sure that the motor cables are sufficiently far from other cables.
- The motor cables must cross other cables at an angle of 90°.
- If it is possible, do not put the motor cables in long parallel lines with other cables.

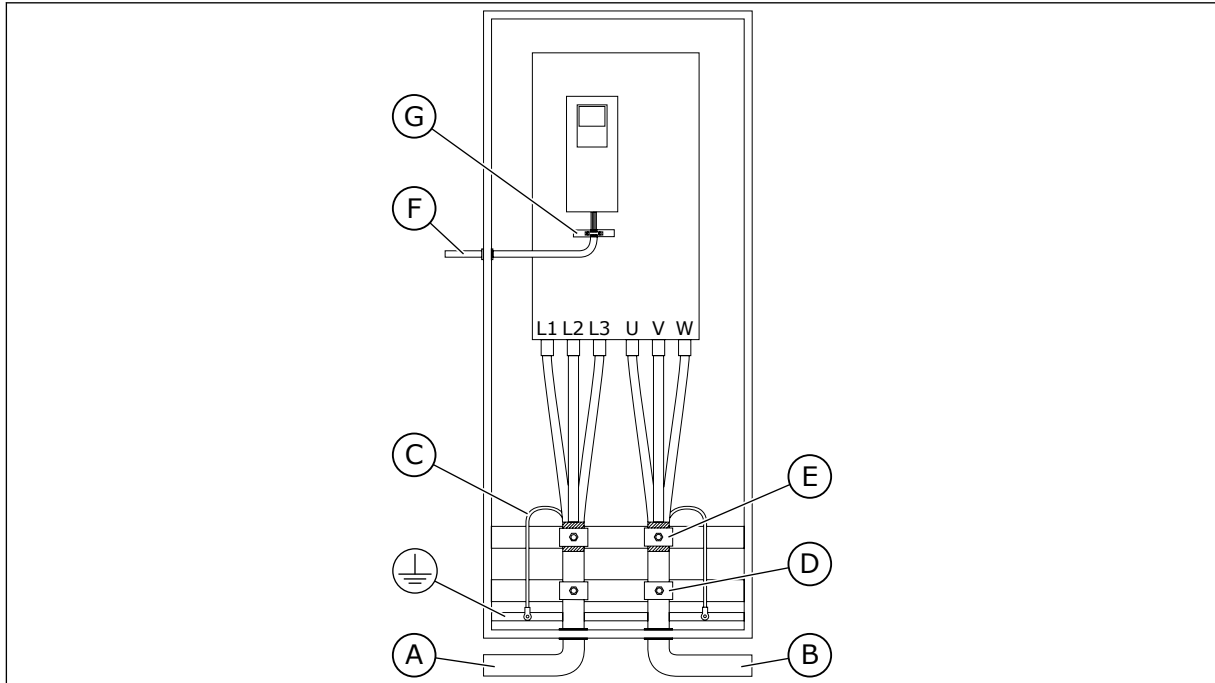

- | | |
|----------------------------|---------------------------------------------------------|
| A. The mains cables | E. The grounding clamp for cable shield, 360° grounding |
| B. The motor cables | F. The control cable |
| C. The grounding conductor | G. The grounding bar of the control cable |
| D. Pull relief | |

- Only use symmetrically EMC shielded mains and motor cables.
- The maximum length of shielded motor cables is 200 m (MR8-MR12).
- If the cable insulation checks are necessary, see chapter 7.3 *Measuring the cable and motor insulation* for instructions.
- If the motor cables are in parallel with other cables, obey the minimum distances.
- The distances are also valid between the motor cables and the signal cables of other systems.

Table 19: The minimum distances between cables

The distance between cables [m]	The length of the shielded cable [m]
0.3	≤ 50
1.0	≤ 200

5.4 CABLE INSTALLATION IN MR8-MR12

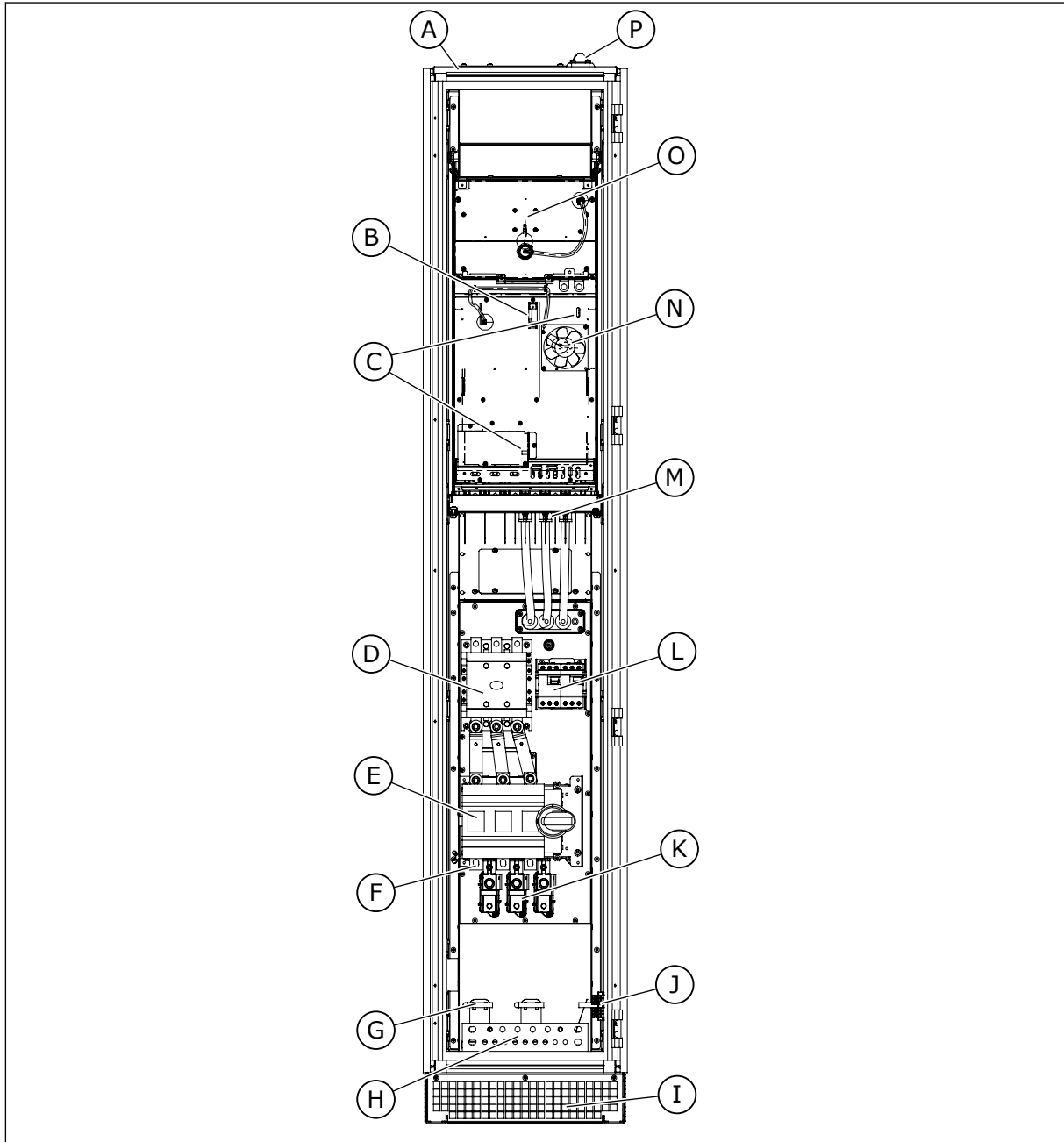

Fig. 24: The inside layout of MR8, without protective covers

- | | |
|--------------------------------------------|---------------------------------------------------------------------------------------|
| A. The output air grill | K. The motor cable terminals with the common mode and/or the du/dt filter options |
| B. The control connector of the power unit | L. The options CAPT and CPIF |
| C. The EMC jumpers | M. The motor cable terminals, without the common mode and/or the du/dt filter options |
| D. The contactor option | N. The internal fan for IP54 |
| E. The main switch option and the fuses | O. The main fan |
| F. The mains cable terminals | P. The cable entry plate for control cables |
| G. The 360-degree grounding | |
| H. The PE bar | |
| I. Input air grill | |
| J. The terminals for the option +CAPU | |

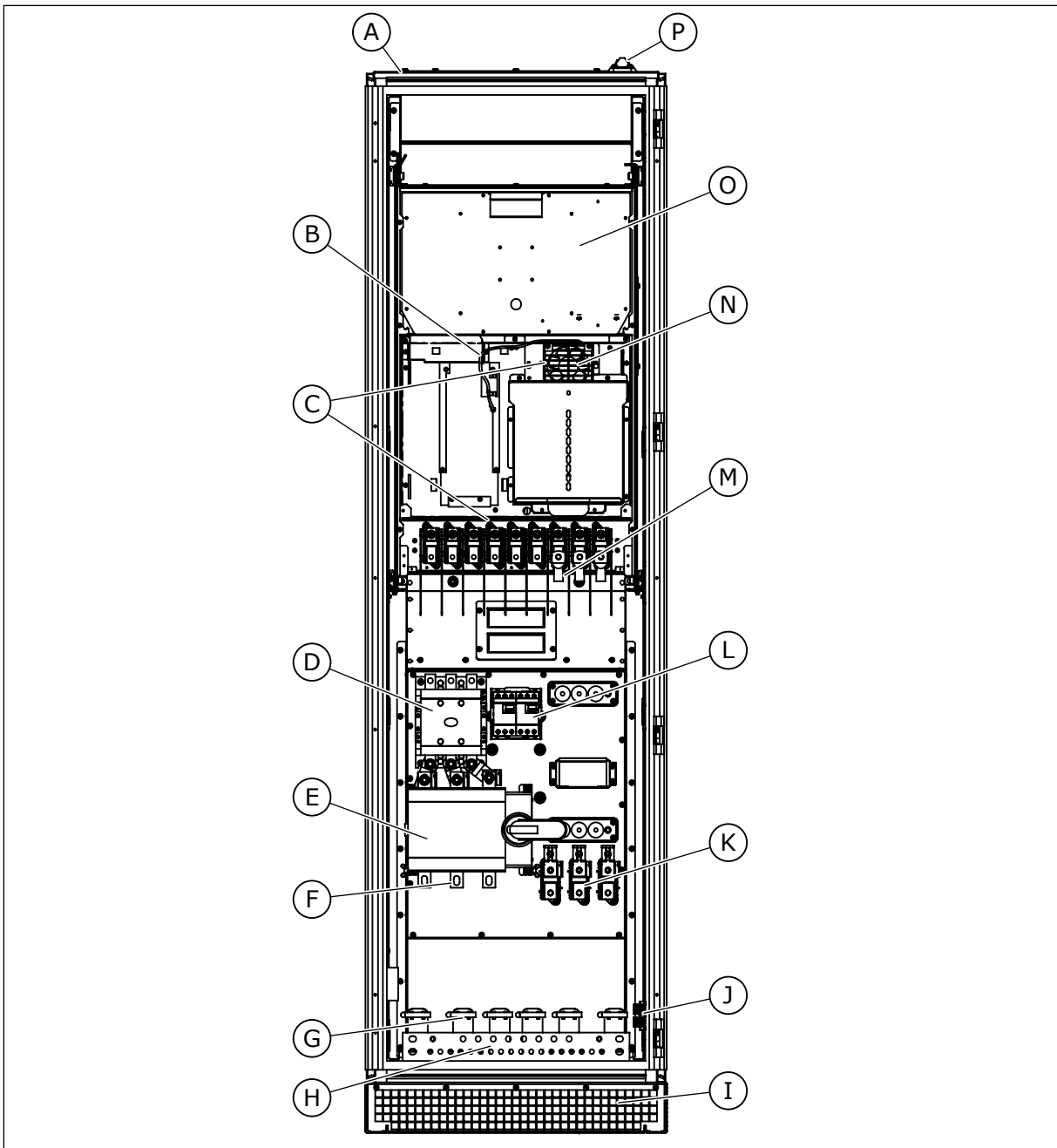

Fig. 25: The inside layout of MR9, without protective covers

- | | |
|--------------------------------------------|---------------------------------------------------------------------------------------|
| A. The output air grill | K. The motor cable terminals with the common mode and/or the du/dt filter options |
| B. The control connector of the power unit | L. The options CAPT and CPIF |
| C. The EMC jumpers | M. The motor cable terminals, without the common mode and/or the du/dt filter options |
| D. The contactor option | N. The internal fan for IP54 |
| E. The main switch option and the fuses | O. The main fan |
| F. The mains cable terminals | P. The cable entry plate for control cables |
| G. The 360-degree grounding | |
| H. The PE bar | |
| I. Input air grill | |
| J. The terminals for the option +CAPU | |

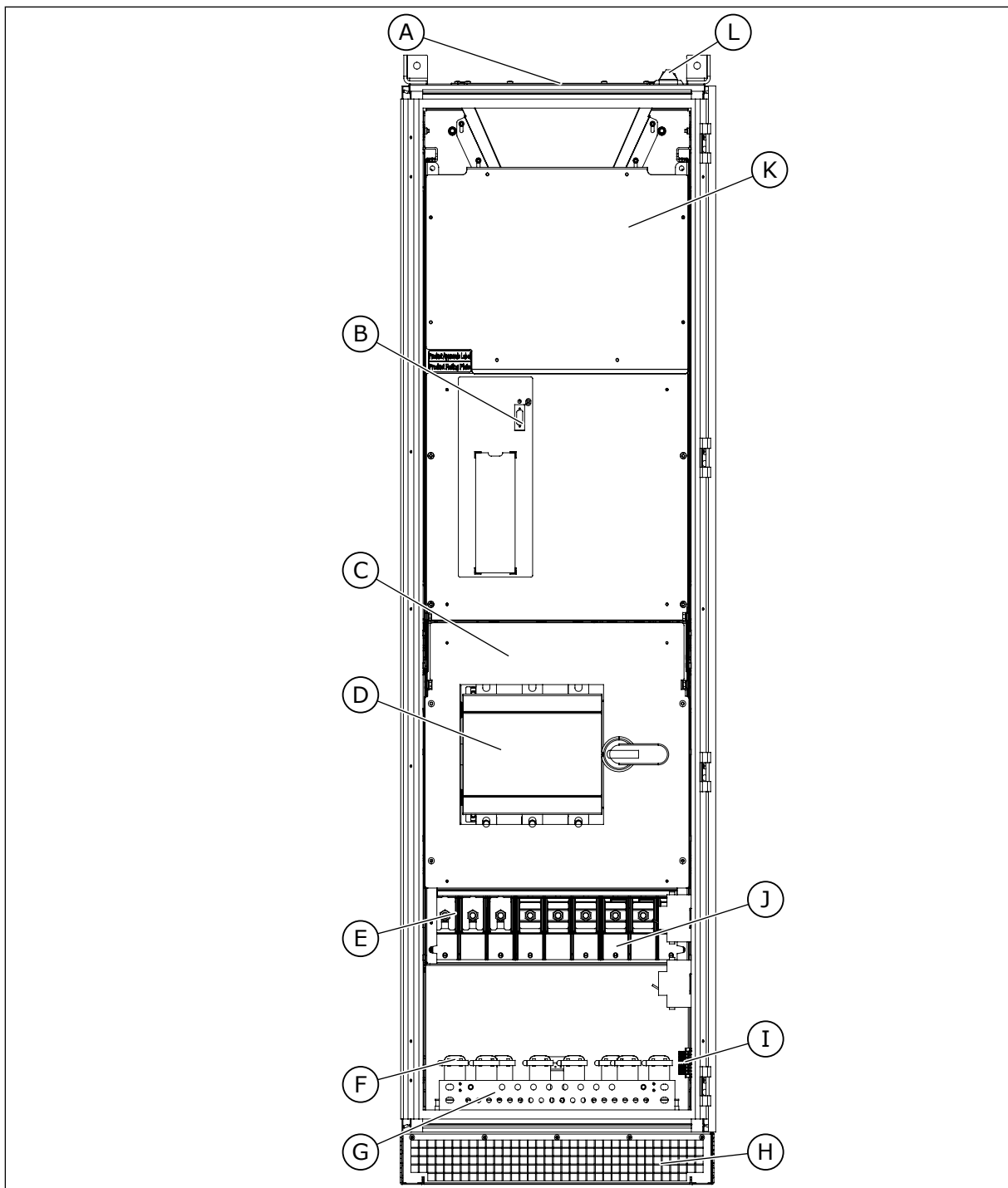

Fig. 26: The inside layout of MR10, without protective covers

- | | |
|--------------------------------------------|-----------------------------------------------|
| A. The output air grill | G. The PE bar |
| B. The control connector of the power unit | H. Input air grill |
| C. The EMC jumper (behind the covers) | I. The terminals for the option +CAPU |
| D. The main switch option and the fuses | J. The motor cable terminals |
| E. The mains cable terminals | K. The service lid, and the main fan under it |
| F. The 360-degree grounding | L. The cable entry plate for control cables |

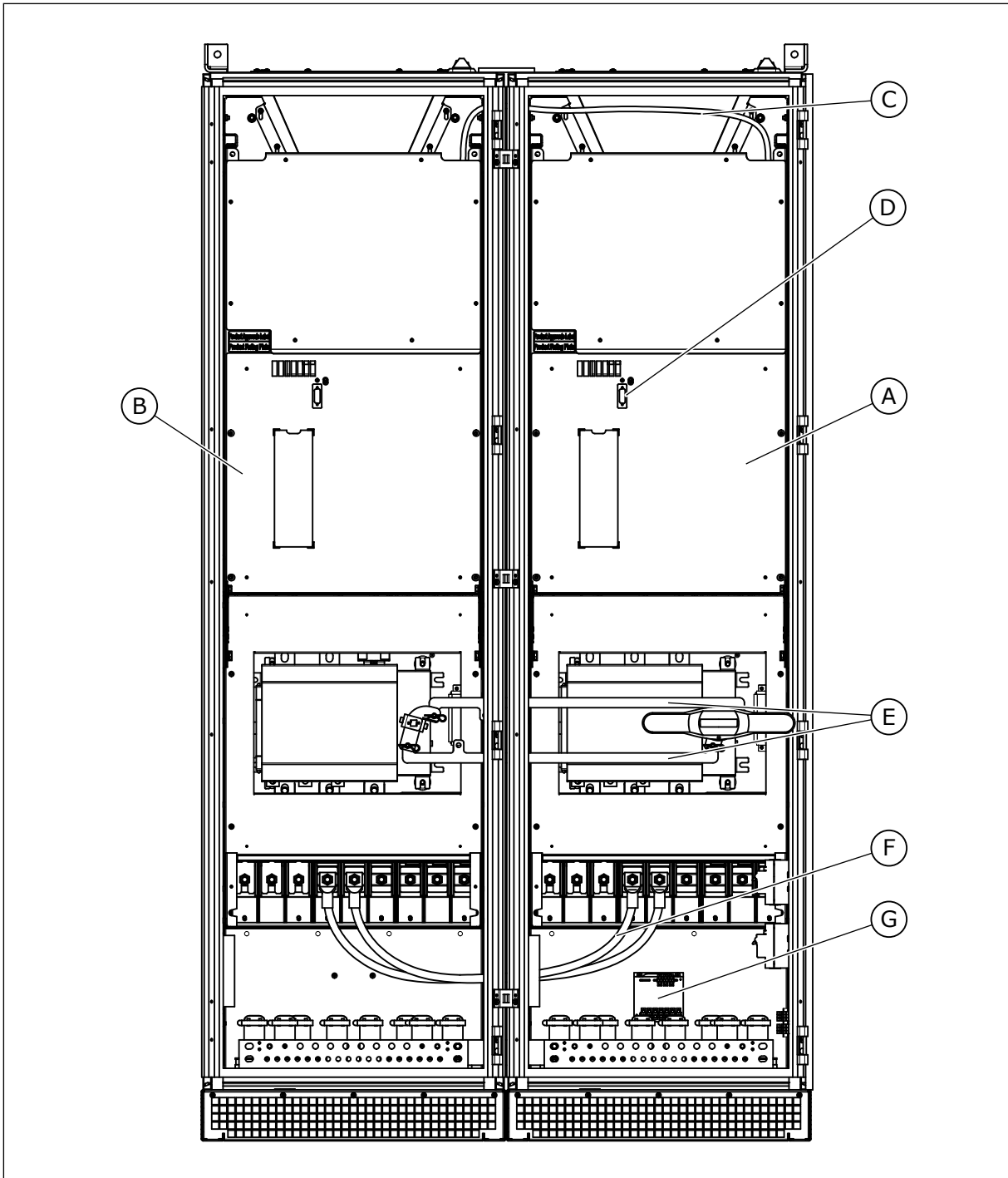

Fig. 27: The inside layout of MR12, without protective covers

- A. Power unit 1
- B. Power unit 2
- C. Optical fibre cables
- D. The connector for control unit cable (in power unit 1)
- E. The fuse switch linkage for the fuse switch option.
- F. The DC link connection

G. The auxiliary voltage transformer

INSTALLING THE CABLES

- 1 Open the cabinet door.
- 2 Remove the covers of the AC drive.
- 3 In MR12, if you have the fuse switch option, remove the the fuse switch linkage.
- 4 Cut the grommets open to move the cables through them.

- a) Do not cut the grommet openings wider than what is necessary for the cables that you use.

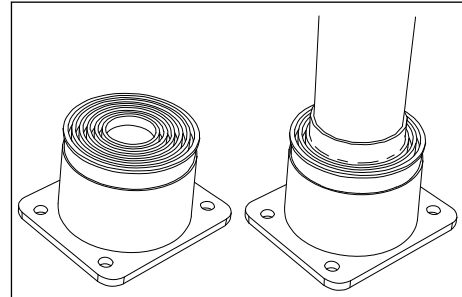

IP54 only

- 5 Put the cables into their places.
- 6 Strip the motor cable and the mains cable.
 - a) Keep the grounding conductor as short as possible, but so that it reaches the grounding bar.
- 7 Strip the brake resistor cable.
 - a) Keep the grounding conductor as short as possible, but so that it reaches the grounding bar.
- 8 Connect the stripped cables.
 - a) Connect the phase conductors of the mains cable and of the motor cable into the correct terminals. If you use a brake resistor cable, connect its conductors into the correct terminals.
 - b) Attach the grounding conductor of each cable to a grounding terminal with a grounding clamp for grounding conductor.
 - c) Make sure that the external grounding conductor is connected to the grounding bar. See chapter 2.4 *Grounding and earth fault protection*.

- 9 If you use many cables on one connector, put the cable lugs on top of each other.
- The picture shows the connection in MR8 and MR9.

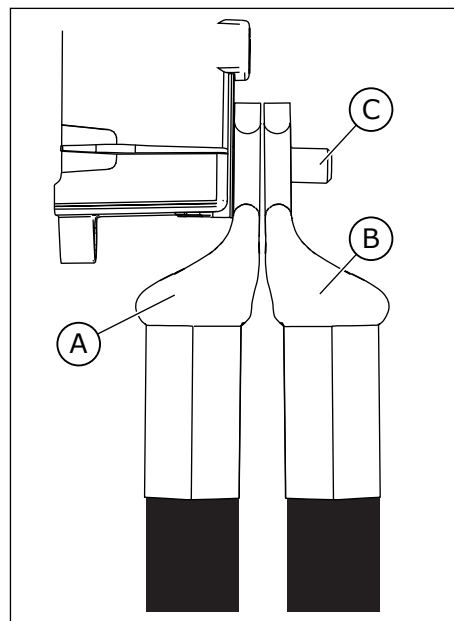

- A. The first cable lug
B. The second cable lug
C. The connector

- 10 If you use many cables on one connector, put the cable lugs on top of each other.
- The pictures show the connection in MR10 and MR12.
 - The bolt holder of the connector keeps the bolt still when you turn the nut.

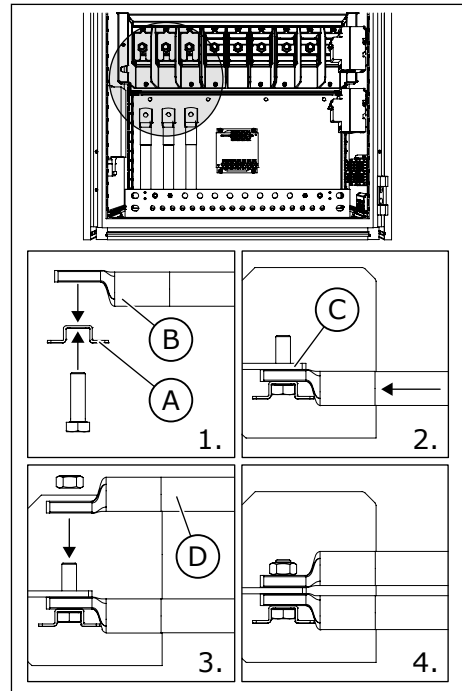

- A. The bolt holder of the connector
- B. The first cable lug
- C. The connector
- D. The second cable lug

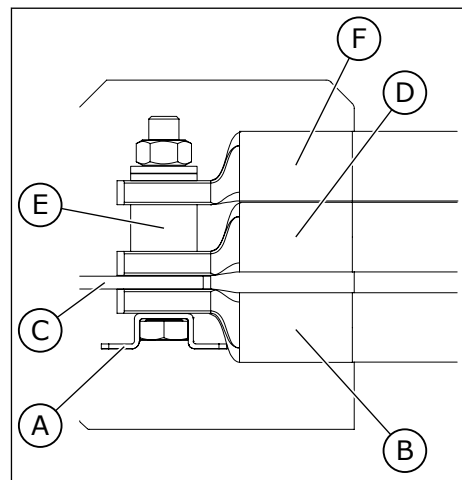

- A. The bolt holder of the connector
- B. The first cable lug
- C. The connector
- D. The second cable lug
- E. The connection bush
- F. The third cable lug

- 11 Expose the shield of all 3 cables to make a 360-degree connection with the grounding clamps for cable shield.

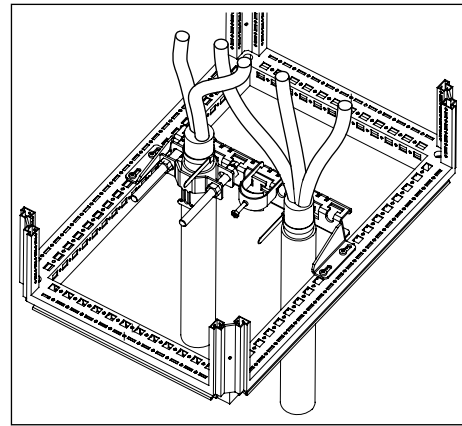

IP21

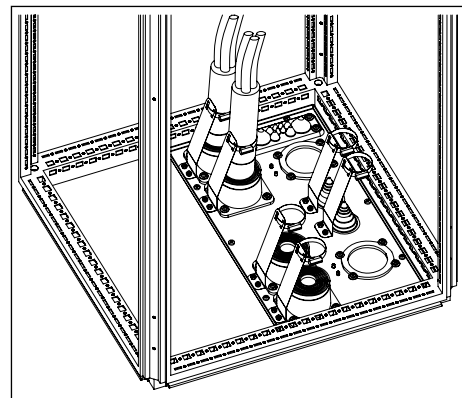

IP54

- 12 Attach the terminal cover, and then the extension box cover.
- 13 Close the cabinet door.
- 14 Make sure that the grounding conductor is connected to the motor and also to the terminals that are identified with \ominus .
- a) To obey the requirements of the standard EN61800-5-1, obey the instructions in chapter 2.4 *Grounding and earth fault protection*.

Table 20: Tightening torques of the terminals, MR8-MR12

Frame	Type	Tightening torque: the mains and motor cable terminals		Tightening torque: the grounding terminals	
		[Nm]	lb-in.	[Nm]	lb-in.
MR8	0140 5-0205 5 0080 7-0125 7	30-44 *	266-389 *	20	177
MR9	0261 5-0310 5 0144 7-0208 7	30-44 *	266-389 *	20	177
MR10	0385 5-0590 5 0261 7-0416 7	55-70	490-620	20	177
MR12	0650 5-1180 5 0460 7-0820 7	55-70	490-620	20	177

* = Counter torque is required for the mains cable terminals.

6 CONTROL COMPARTMENT

6.1 THE CONTROL COMPARTMENT OF THE ENCLOSED DRIVE

The enclosed drive has a door-mounted control compartment, separated from the cabinet section, for the mains and motor cable terminals. You can have an access to the control compartment through a separate door located on the cabinet door.

Connect the analogue signals (for example reference signals and temperature signals) and the fieldbus cables directly to the correct option board.

Make sure that the control cables are long enough to prevent tight bends in the cables between the control compartment and the frame of the drive.

The control compartment contains these items:

- the control unit
- the control panel
- the option boards
- the optional auxiliary components and the related wires
- the terminals for internal connections
- the terminals for control cabling
- the order-specific documentation (on the inside of the door)
- the optional buttons and signal lights (on the door)

Connect the cables of the option boards OPTB2, OPTB4, OPTB5, OPTF3 and OPTF4 (depending on the configuration of the drive) as default to the terminals for control cabling – XD2 on the control compartment. Do not connect the fieldbus board cables to these terminals, but directly to the control terminals or the Ethernet terminal on the control unit.

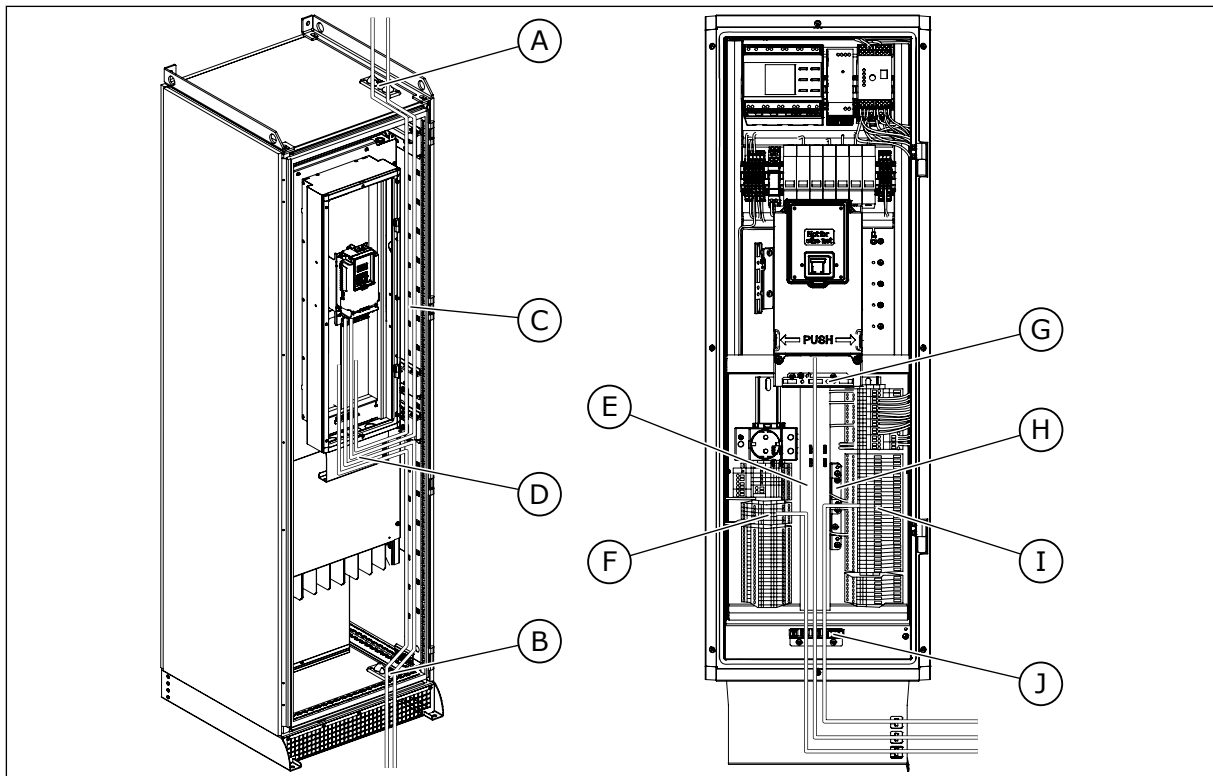

Fig. 28: Control cabling of the enclosed drive

- A. I/O cabling from top
- B. I/O cabling from bottom
- C. The cable routing plate with places for cable ties
- D. The cable carrier
- E. The cable ducts
- F. The extended I/O terminals (+CTID) to be used freely
- G. The control grounding plate
- H. The customer grounding plate
- I. The terminals for control cabling (default)
- J. Grounding clamps for cable shield

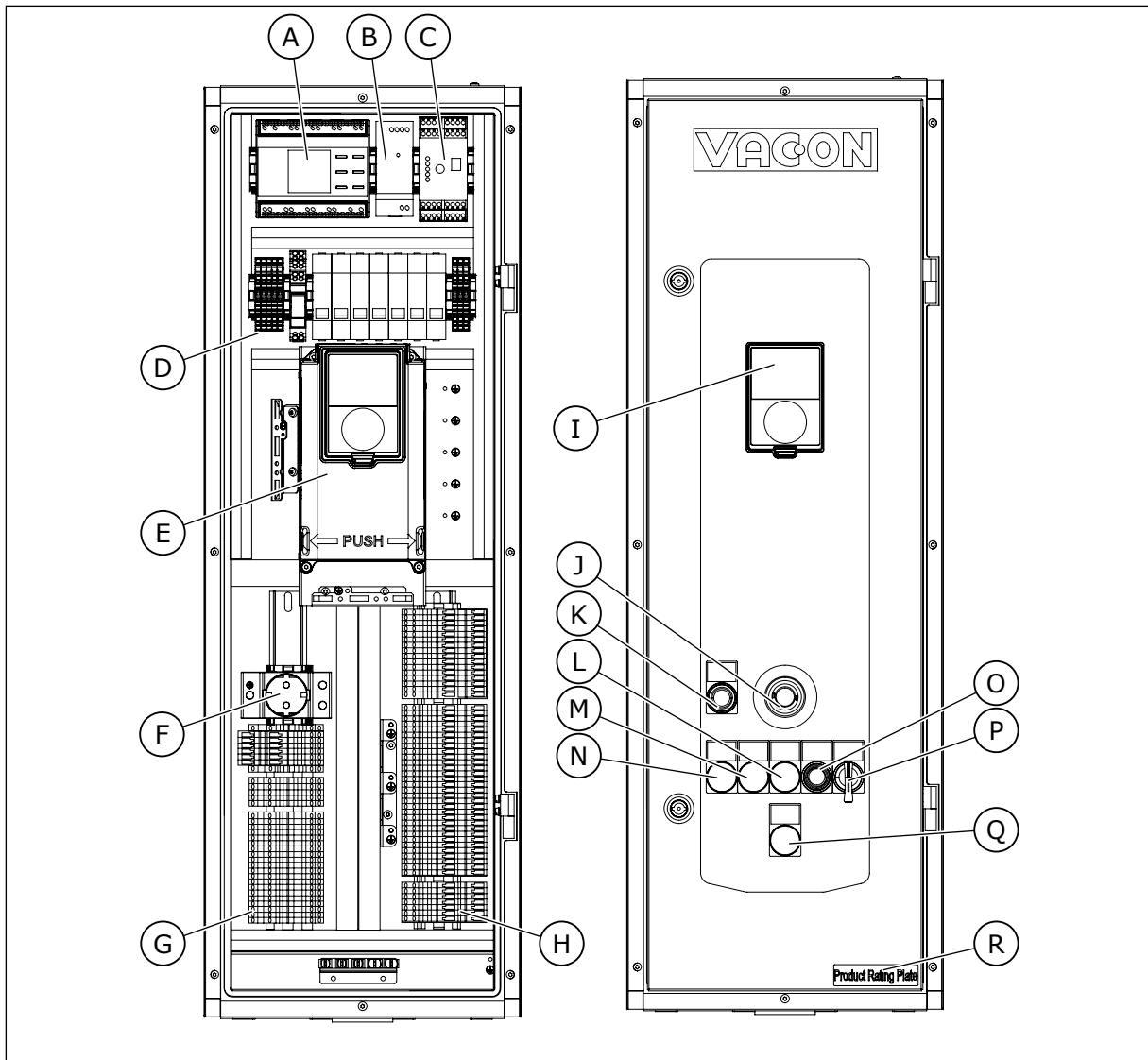

Fig. 29: The control compartment components of the cabinet

- | | |
|--------------------------------------------------------------------------------------------------------------------------------------------------------------------------------------------------------------------------------------------------------------------------------------------------------------------------------------------------------------------------------------------------------------------------------------------------------------------------------------------------------------------------|------------------------------------------------------------------------------------------------------------------------------------------------------------------------------------------------------------------------------------------------------------------------------------------------------------------------------------------------------------------------------------------------------------------------------------------|
| <ul style="list-style-type: none"> A. The insulation fault sensor (+CPIF) B. The 24 VDC power supply (+CAPD) C. The emergency stop Cat 1 (+CPS1) D. The MCBs for auxiliary devices E. The control unit F. The 230 VAC socket (+CAPS) G. The extended I/O terminals (+CTID) to be used freely H. The terminals for control cabling (default) I. The control panel J. The emergency stop push button (+CPS0, +CPS1, +CPSB) | <ul style="list-style-type: none"> K. The emergency stop reset button (+CPS1) L. The Fault signal light (+CDLP) M. The Run signal light (+CDLP) N. The Ready signal light (+CDLP) O. The Reset button (+CDLP) P. The 0 - 1 - start switch (+CICO) Q. The insulation fault (+CPIF) R. The rating plate of the drive, the option codes and the serial number |
|--------------------------------------------------------------------------------------------------------------------------------------------------------------------------------------------------------------------------------------------------------------------------------------------------------------------------------------------------------------------------------------------------------------------------------------------------------------------------------------------------------------------------|------------------------------------------------------------------------------------------------------------------------------------------------------------------------------------------------------------------------------------------------------------------------------------------------------------------------------------------------------------------------------------------------------------------------------------------|

6.2 FIELDBUS CONNECTION

You can connect the drive to fieldbus with an RS485 or an Ethernet cable. If you use an RS485 cable, connect it to terminal A and B of the standard I/O board. If you use an Ethernet cable, connect it to the Ethernet terminal below the cover of the drive.

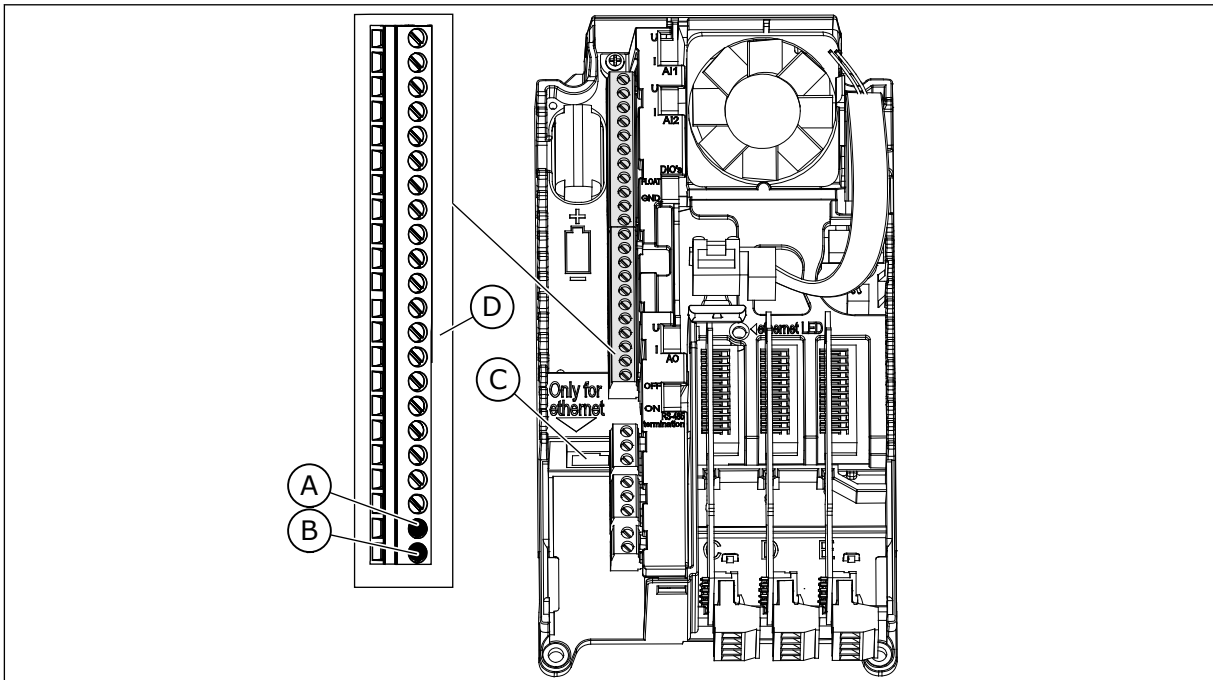

Fig. 30: The Ethernet and RS485 connections

- A. RS485 terminal A = Data -
- B. RS485 terminal B = Data +
- C. The Ethernet terminal
- D. The control terminals

6.2.1 USING FIELDBUS THROUGH AN ETHERNET CABLE

Table 21: Ethernet cable data

Item	Description
The plug type	A shielded RJ45 plug, maximum length 40 mm
The cable type	CAT5e STP
The cable length	Maximum 100 m (328 ft)

ETHERNET CABLING

- 1 Connect the Ethernet cable to its terminal.
- 2 Put the cover of the drive back. Keep the distance between the Ethernet cable and the motor cable at a minimum of 30 cm.

See more in the Installation Manual of the fieldbus that you have.

6.2.2 USING FIELDBUS THROUGH AN RS485 CABLE

Table 22: RS485 cable data

Item	Description
The plug type	2.5 mm ²
The cable type	STP (shielded twisted pair), Belden 9841 or almost the same
The cable length	So that it agrees with the fieldbus. See the fieldbus manual.

RS485 CABLING

- 1 Remove approximately 15 mm (0.59 in) of the grey shield of the RS485 cable. Do this for the 2 fieldbus cables.
 - a) Strip the cables for approximately 5 mm (0.20 in) to put them in the terminals. Do not keep more than 10 mm (0.39 in) of the cable outside the terminals.
 - b) Strip the cable at such a distance from the terminal that you can attach it to the frame with the grounding clamp for control cable. Strip the cable at a maximum length of 15 mm (0.59 in). Do not remove the aluminium shield of the cable.

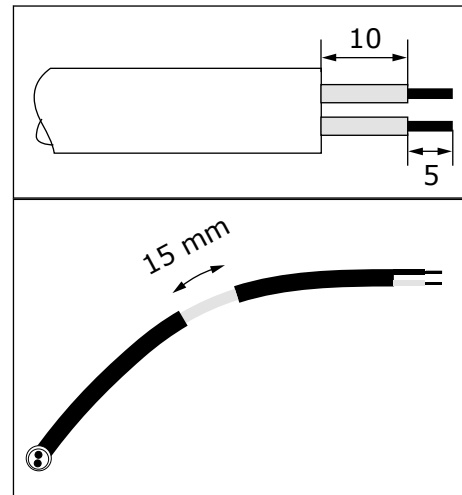

- 2 Connect the cable to the standard I/O board of the drive, in terminals A and B.

- A = negative
- B = positive

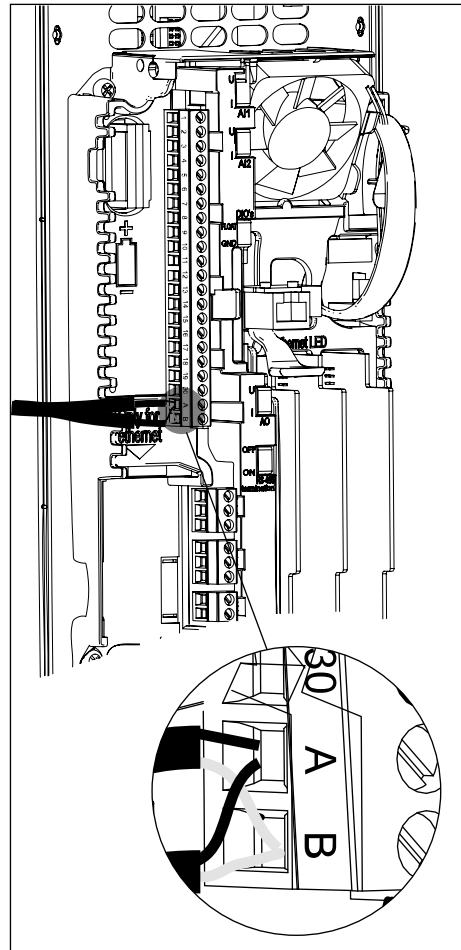

- 3 Attach the shield of the cable to the frame of the drive with a grounding clamp for control cable to make a grounding connection.

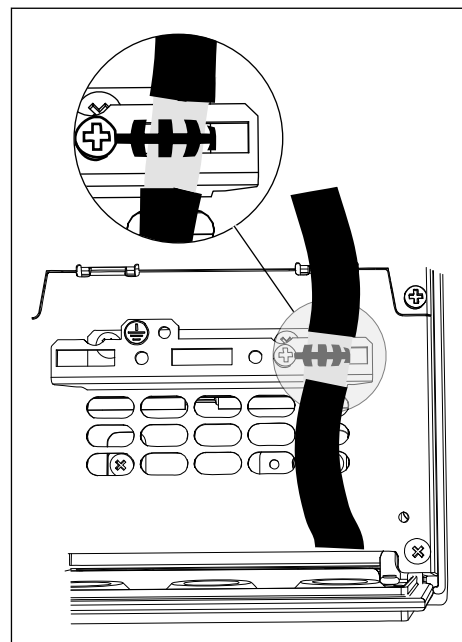

- 4 If the drive is the last device on the fieldbus line, set the bus termination.
 - a) Find the DIP switches on the left side of the control unit of the drive.
 - b) Set the DIP switch of the RS485 bus termination to the ON position.
 - c) Biasing is built in the bus termination resistor. The termination resistance is 220 Ω.

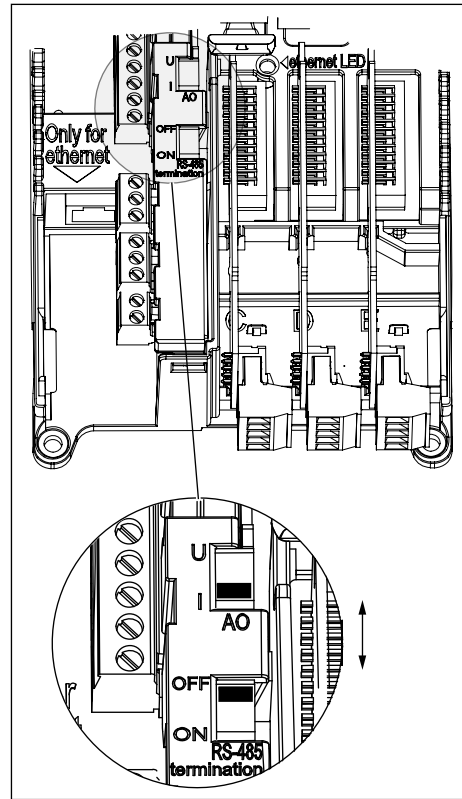

- 5 Set the bus termination for the first and the last device of the fieldbus line. We recommend that the first device on the fieldbus is the master device.

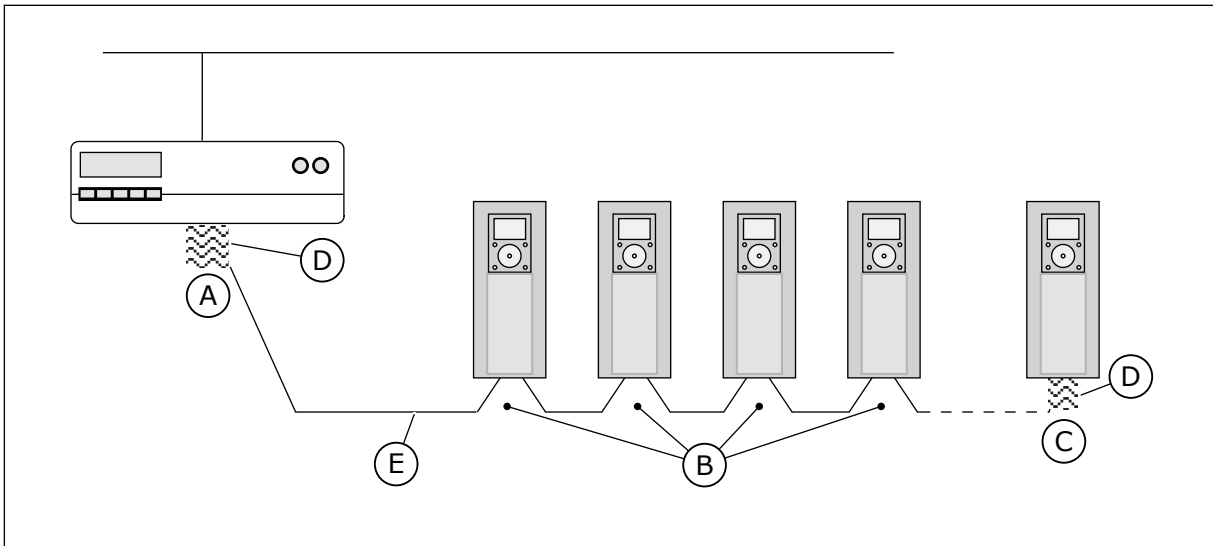

- | | |
|---------------------------------------------------|--------------------------------------------------|
| A. The termination is activated | D. The bus termination. The resistance is 220 Ω. |
| B. The termination is deactivated | E. The fieldbus |
| C. The termination is activated with a DIP switch | |

**NOTE!**

If you do power-down to the last device, there is no bus termination.

7 COMMISSIONING AND ADDITIONAL INSTRUCTIONS

7.1 COMMISSIONING SAFETY

Before you start the commissioning, read these warnings.

**WARNING!**

Do not touch the internal components or the circuit boards of the drive when the drive is connected to mains. These components are live. A contact with this voltage is very dangerous. The galvanically isolated control terminals are not live.

**WARNING!**

Do not touch the motor cable terminals U, V, W, the brake resistor terminals or the DC terminals when the drive is connected to mains. These terminals are live when the drive is connected to mains, also when the motor does not operate.

**WARNING!**

Do not make connections to or from the AC drive when it is connected to mains. There is a dangerous voltage.

**WARNING!**

To do work on the connections of the drive, disconnect the drive from mains. Wait 5 minutes before you open the cabinet door or the cover of the drive. Then use a measuring device to make sure that there is no voltage. The connections of the drive are live 5 minutes after it is disconnected from mains.

**WARNING!**

Before you do electrical work, make sure that there is no voltage.

**WARNING!**

Do not touch the control terminals. They can have a dangerous voltage also when the drive is disconnected from mains.

**WARNING!**

Before you connect the drive to mains, make sure that the front cover and the cable cover of the drive are closed. The connections of the AC drive are live when the drive is connected to mains.

7.2 OPERATION OF THE MOTOR

7.2.1 CHECKS BEFORE STARTING THE MOTOR

Before you start the motor, do these checks.

- Make sure that all the START and STOP switches that are connected to the control terminals are in the STOP position.
- Make sure that you can start the motor safely.
- Activate the Start-up wizard. See the Application Manual for the AC drive that you have.
- Set the maximum frequency reference (that is, the maximum speed of the motor), so that it agrees with the motor and the device that is connected to the motor.

7.3 MEASURING THE CABLE AND MOTOR INSULATION

Do these checks if necessary.

The insulation checks of the motor cable

1. Disconnect the motor cable from the terminals U, V, and W and from the motor.
2. Measure the insulation resistance of the motor cable between phase conductors 1 and 2, between phase conductors 1 and 3, and between phase conductors 2 and 3.
3. Measure the insulation resistance between each phase conductor and the grounding conductor.
4. The insulation resistance must be $>1 \text{ M}\Omega$ at the ambient temperature of $20 \text{ }^\circ\text{C}$ ($68 \text{ }^\circ\text{F}$).

The insulation checks of the mains cable

1. Disconnect the mains cable from the terminals L1, L2, and L3 and from mains.
2. Measure the insulation resistance of the mains cable between phase conductors 1 and 2, between phase conductors 1 and 3, and between phase conductors 2 and 3.
3. Measure the insulation resistance between each phase conductor and the grounding conductor.
4. The insulation resistance must be $>1 \text{ M}\Omega$ at the ambient temperature of $20 \text{ }^\circ\text{C}$ ($68 \text{ }^\circ\text{F}$).

The insulation checks of the motor

1. Disconnect the motor cable from the motor.
2. Open the bridging connections in the motor connection box.
3. Measure the insulation resistance of each motor winding. The voltage must be the same or higher than the motor nominal voltage, but not higher than 1000 V .
4. The insulation resistance must be $>1 \text{ M}\Omega$ at the ambient temperature of $20 \text{ }^\circ\text{C}$ ($68 \text{ }^\circ\text{F}$).
5. Obey the instructions of the motor manufacturer.

7.4 INSTALLATION IN A MARINE ENVIRONMENT

When you install the AC drive in a marine environment, see the Marine Installation Guide.

7.5 INSTALLATION IN AN IT SYSTEM

If your mains is impedance-grounded (IT), the AC drive must have the EMC protection level C4. If your drive has the EMC protection level C3, it is necessary to change it to C4. To do this, remove the EMC jumper.

**WARNING!**

Do not make changes in the AC drive when it is connected to mains. The components of the drive are live when the drive is connected to mains.

**CAUTION!**

Before you connect the AC drive to mains, make sure that the EMC level of the drive is correct. An incorrect EMC level can cause damage to the drive.

7.5.1 THE EMC JUMPER IN MR8

Change the EMC protection of the AC drive from level C3 to level C4.

- 1 Open the cover of the AC drive.
- 2 Find the EMC box. To get access to the EMC jumper, remove the cover of the EMC box.

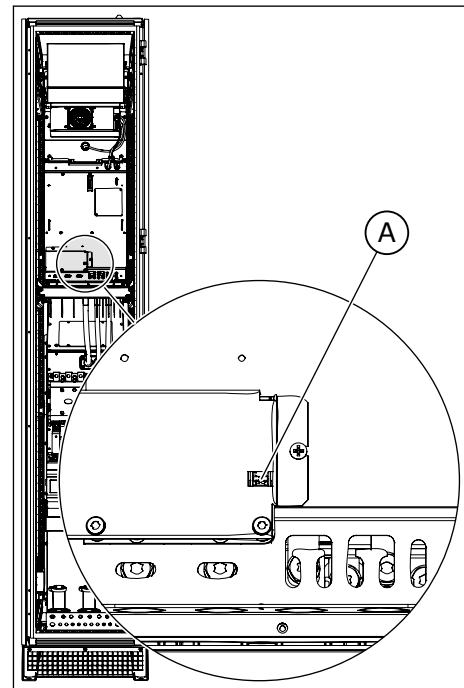

A. The EMC jumper

- 3 Remove the EMC jumper. Attach the cover of the EMC box again.

- 4 Find the grounding arm and push it down.

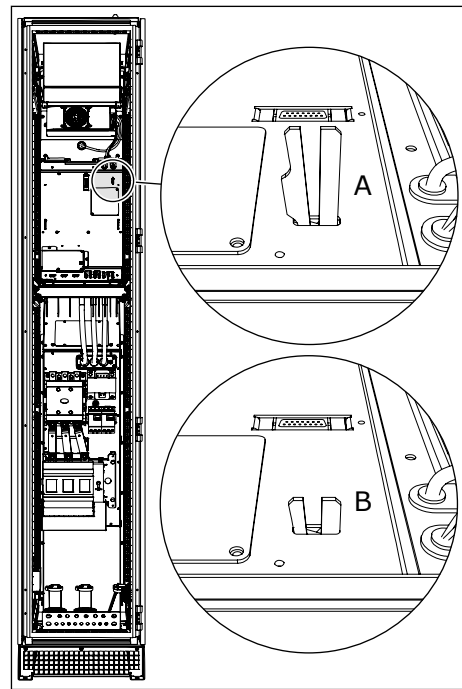

- A. The grounding arm is up
- B. The grounding arm is down (level C3)

- 5 After the change, write "The EMC level was changed" and the date on the "product changed" label. If the label is not attached at this time, attach it on the drive near the name plate.

Product modified	
	Date:
	Date:
	Date:

7.5.2 THE EMC JUMPER IN MR9

Change the EMC protection of the AC drive from level C3 to level C4.

THE EMC JUMPER 1

- 1 Open the covers of the AC drive.

- 2 Loosen the screws of the cover plate and remove it.

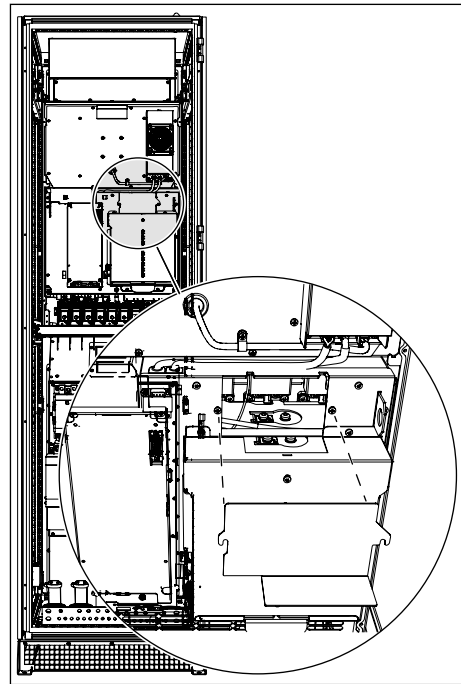

- 3 Remove the EMC jumper.

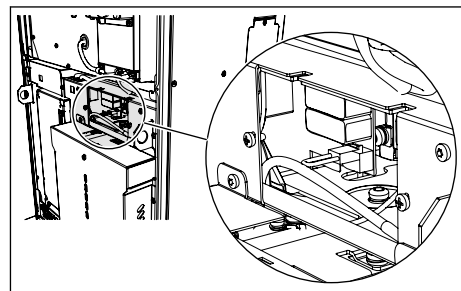

- 4 If you change the EMC level, write "The EMC level was changed" and the date on the "product changed" label. If the label is not attached at this time, attach it on the drive near the name plate.

Product modified	
.....	Date:
.....	Date:
.....	Date:

THE EMC JUMPERS 2 AND 3

- 1 Remove the cover of the extension box, the touch shield, and the I/O plate with the I/O grommet plate.

- 2 Find the 2 EMC jumpers on the EMC board. They are not adjacent to each other. Remove the EMC jumpers.

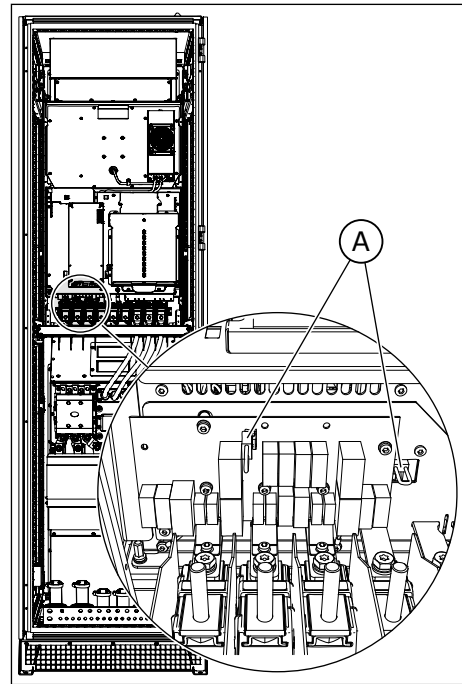

A. The EMC jumpers

- 3 If you change the EMC level, write "The EMC level was changed" and the date on the "product changed" label. If the label is not attached at this time, attach it on the drive near the name plate.

Product modified	
.....	Date:
.....	Date:
.....	Date:

7.5.3 THE EMC JUMPER IN MR10 AND MR12

Change the EMC protection of the AC drive from level C3 to level C4.

FINDING THE EMC JUMPER, WITH AN EXTENSION BOX

- 1 Remove the covers of the AC drive.
 - In MR12, do these steps for each power unit. Also remove the fuse switch linkage.

- 2 Find the EMC jumper between the terminals L2 and L3.

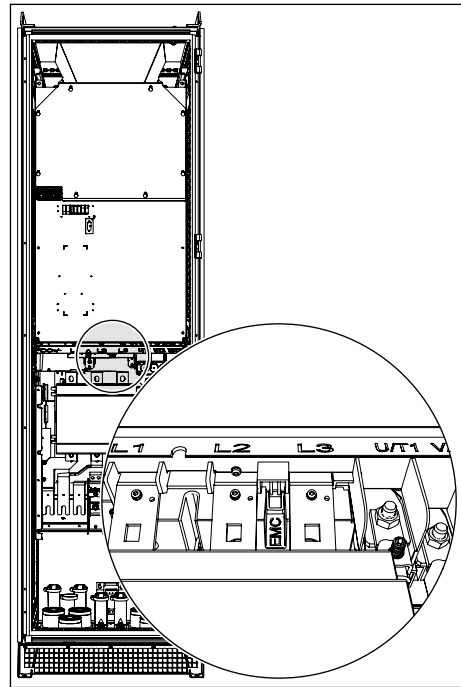

- 3 Remove the EMC jumper.

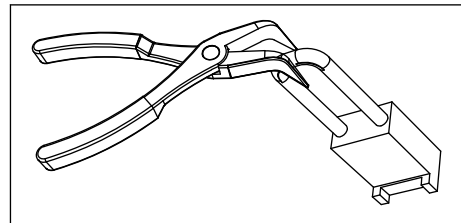

- 4 If you change the EMC level, write "The EMC level was changed" and the date on the "product modified" label. If the label is not attached at this time, attach it on the drive near the name plate.

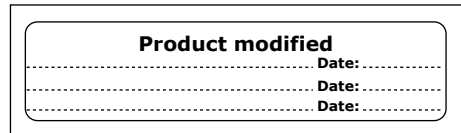

7.6 MAINTENANCE

7.6.1 MAINTENANCE INTERVALS

To make sure that the drive operates correctly and has a long life, we recommend that you do regular maintenance. Refer to *Table 23*.

It is not necessary to replace the main capacitors of the drive, because they are a thin film type capacitors.



WARNING!

Do not make changes in the AC drive when it is connected to mains. The components of the drive are live when the drive is connected to mains.

Table 23: The maintenance intervals and tasks

Maintenance interval	Maintenance task
Regularly	Do a check of the tightening torques of the terminals. Do a check of the filters.
6-24 months (The interval is different in different environments.)	Do a check of the mains and motor cable terminals and the control terminals. Make sure that the cooling fan operates correctly. Make sure that there is no corrosion on the terminals, the busbars or other surfaces. Do a check of the door filters of the cabinet. Do a check of the internal filter of the power unit.
24 months (The interval is different in different environments.)	Clean the heatsink and the cooling tunnel.
6-10 years	Replace the main fan. Replace the internal fans if the drive has them. Replace the fan power supply.
10 years	Replace the battery of the RTC. The battery is optional.

This table is valid for Vacon components. To do maintenance on components that are made by other manufacturers, obey the manual of the component in question.

7.6.2 REPLACING THE AIR FILTERS OF THE AC DRIVE

Clean or replace the filters of the cabinet regularly.

REPLACING THE FILTER ON THE CABINET DOOR

- 1 To remove the cover of the filter, pull it out and up.

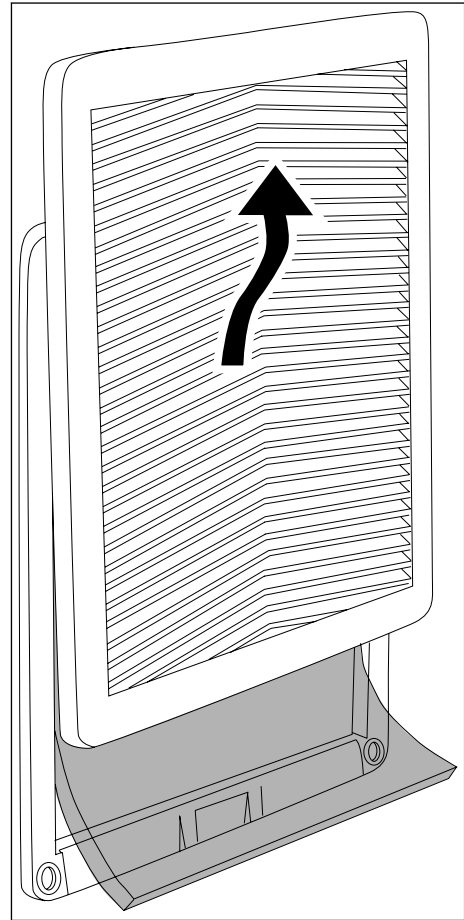

- 2 Clean or replace the filter.
- 3 Put the cover of the filter back.

7.6.3 REPLACING THE FANS OF THE AC DRIVE

7.6.3.1 Replacing the fans in MR8

Here are the instructions on how to replace the fans of the drive.

REPLACING THE FAN POWER SUPPLY, MR8

- 1 Remove the cover of the AC drive.

- 2 Disconnect the cables from the fan power supply.
 - a) Disconnect the fan supply cable from connector X81.
 - b) Disconnect the fan driver cable from connector X61.
 - c) Disconnect the DC supply cable from connector X8.

Remove the 4 screws that hold the fan power supply.

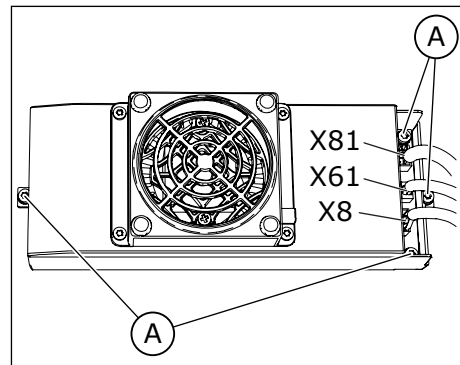

A. The 4 screws

- 3 Lift off the fan power supply.
- 4 Replace the fan power supply. Attach it with the screws.
- 5 Connect the cables and put the cover of the drive back.

REPLACING THE MAIN FAN, MR8

- 1 Remove the cover of the AC drive.
- 2 Remove the fan power supply. See the previous instructions.
- 3 Remove the 4 screws that hold the main fan unit. Lift off the main fan unit.

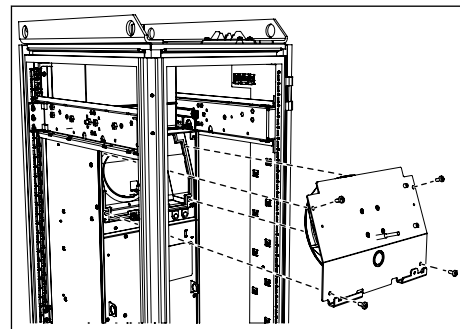

- 4 To release the fan from the cover plate, remove the 4 screws.

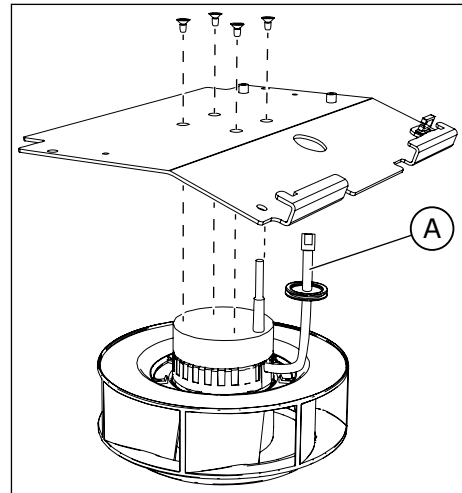

A. The fan cable

- 5 Release the grommet on the fan cable from the cover plate and pull out the cable.
- 6 Replace the main fan. Attach the screws.
- 7 Re-assemble the drive and connect the cables.

7.6.3.2 Replacing the fans in MR9

Here are the instructions on how to replace the fans of the drive.

REPLACING THE FAN POWER SUPPLY, MR9

- 1 Remove the cover of the AC drive.
- 2 Disconnect the cables from the fan power supply.
 - a) Disconnect the fan supply cable from connector X81.
 - b) Disconnect the fan driver cable from connector X61.
 - c) Disconnect the DC supply cable from connector X8.

Remove the 4 screws that hold the fan power supply.

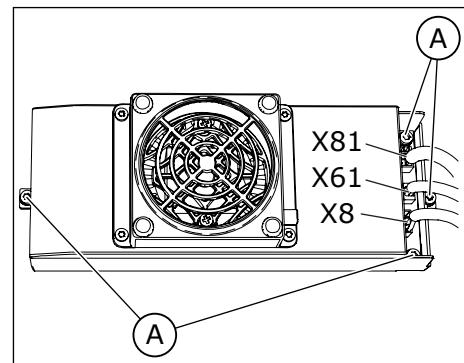

A. The 4 screws

- 3 Lift off the fan power supply.
- 4 Replace the fan power supply. Attach it with the screws.
- 5 Connect the cables and put the cover of the drive back.

REPLACING THE MAIN FAN, MR9

- 1 Remove the cover of the AC drive.

- 2 Disconnect the cables from the fan power supply.
- 3 Remove the 12 screws from the fan cover plate.
Use the handle to lift off the main fan unit.

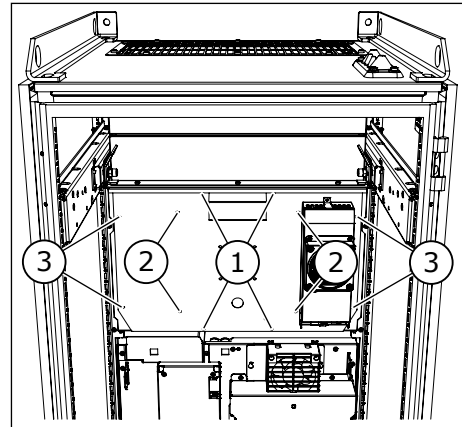

- 4 To release the fan from the cover plate, remove the 4 screws.

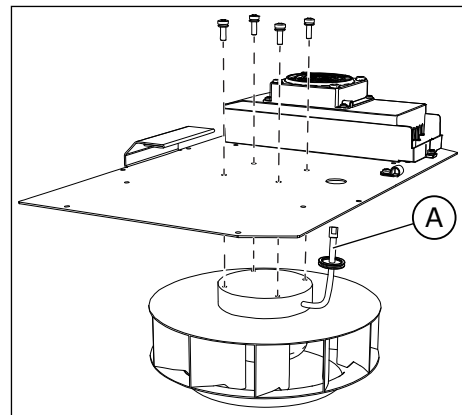

A. The fan cable

- 5 Release the grommet on the fan cable from the cover plate and pull out the cable.
- 6 Replace the main fan.
 - a) When you re-attach the main fan unit, make sure that the sealing tape under the fan plate is in good condition.
 - b) Attach the screws in the tightening order that is marked in the figure of the main fan unit (1 > 2 > 3).
- 7 Re-assemble the drive and connect the cables.

7.6.3.3 Replacing the fans in MR10 and MR12

Here are the instructions on how to replace the fans of the drive.

REPLACING THE MAIN FAN ASSEMBLY, MR10 AND MR12

- 1 Loosen the 8 screws and lift off the service lid.

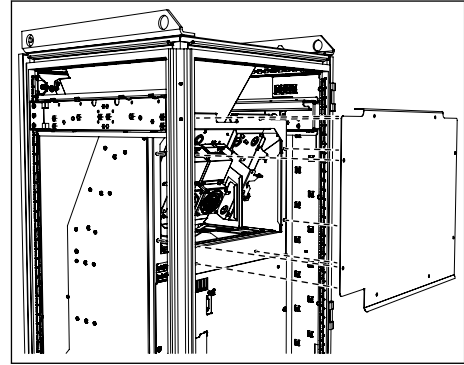

- 2 Disconnect the cables from each fan power supply.

- a) Disconnect the fan driver cable from connector X61.
- b) Disconnect the DC supply cable from connector X8.

Remove the 5 screws.

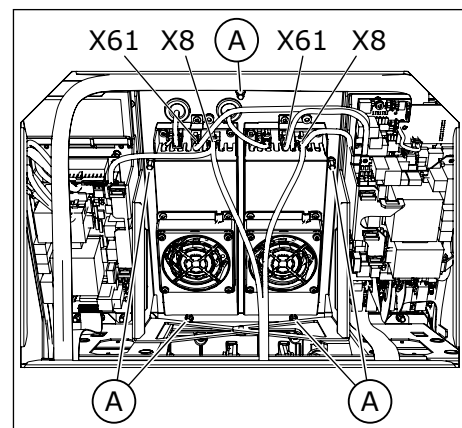

A. The 5 screws

- 3 Pull out the whole fan assembly. The assembly weighs approximately 11 kg.

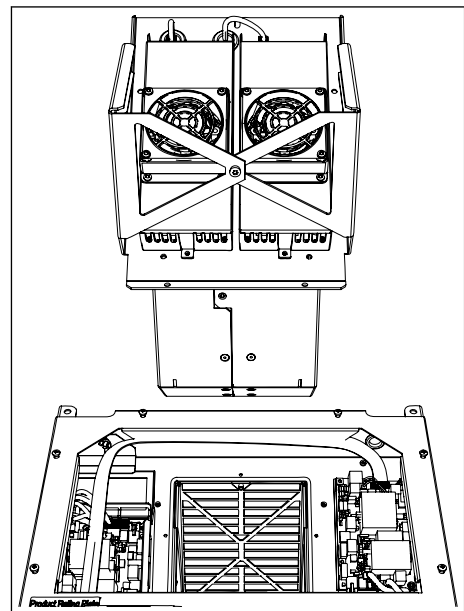

- 4 Replace the main fan assembly. Attach it with the screws.
- 5 Connect the cables and attach the service lid.

REPLACING THE FAN POWER SUPPLIES, MR10 AND MR12

You can replace only 1 or both the fan power supplies.

- 1 Remove the main fan assembly. See the previous instructions.
- 2
 - a) Disconnect the fan supply cable from connector X81.
 - b) Disconnect the fan driver cable from connector X61.
 - c) Disconnect the DC supply cable from connector X8.

Remove the 4 screws from each supply.

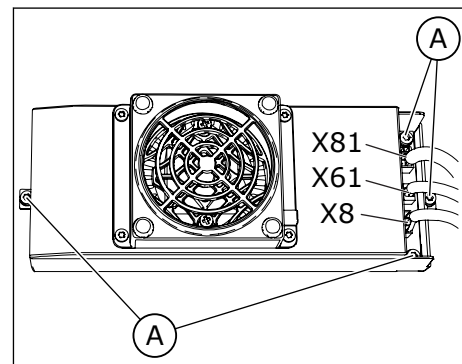

A. The 4 screws

- 3 Replace the fan power supplies.
- 4 Attach the screws, connect the cables, and re-assemble the drive.

7.6.4 REPLACING THE POWER UNIT OF THE AC DRIVE

7.6.4.1 Replacing the power unit, MR8

- 1 Remove the protective covers of the drive.
- 2 Disconnect all the power cables from the bottom of the power unit.

- 3 Remove the 2 screws from the top of the power unit.

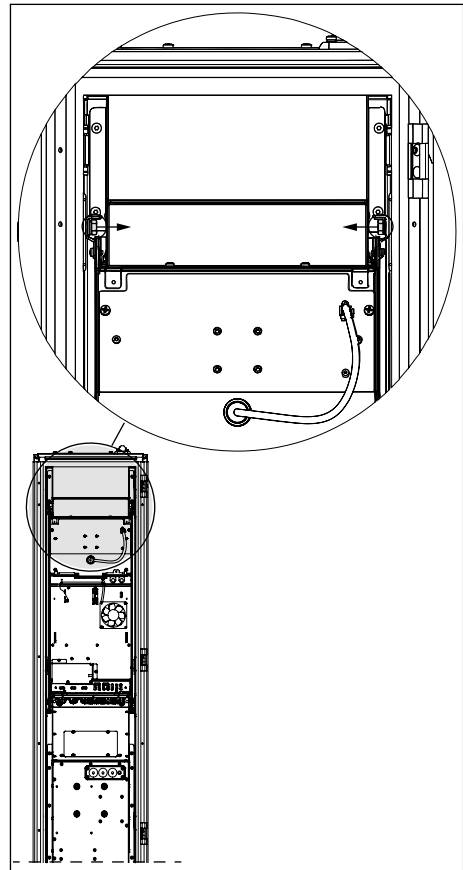

- 4 Remove the 6 screws from the bottom of the power unit.

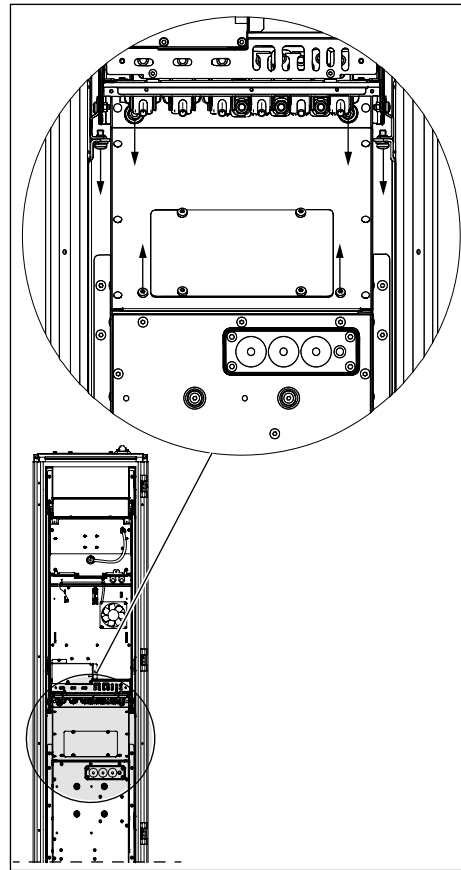

- 5 Pull the power unit out carefully until it is possible to use the front lifting holes.

- 6 Attach the lifting hooks to the front lifting holes and lift the power unit out of the cabinet.

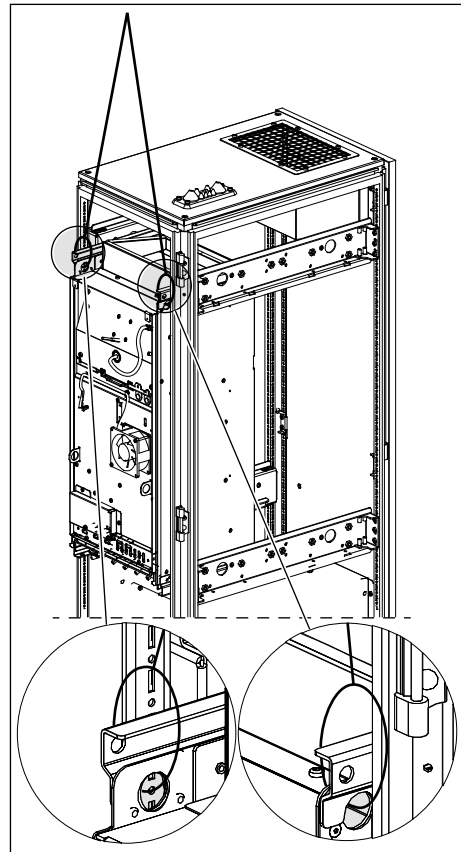

7.6.4.2 Replacing the power unit, MR9

- 1 Remove the protective covers of the drive.
- 2 Disconnect all the power cables from the bottom of the power unit.

- 3 Remove the 2 screws from the top of the power unit. Also remove the lifting lugs. You will re-attach them later.

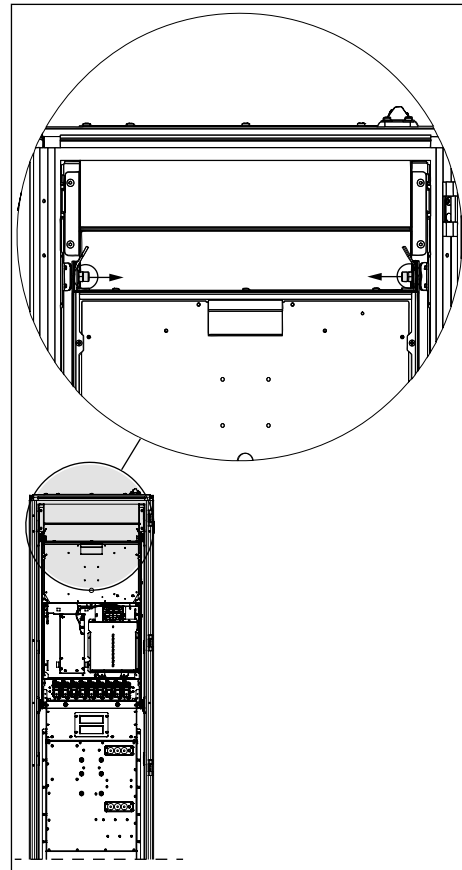

- 4 Remove the 8 screws from the bottom of the power unit.

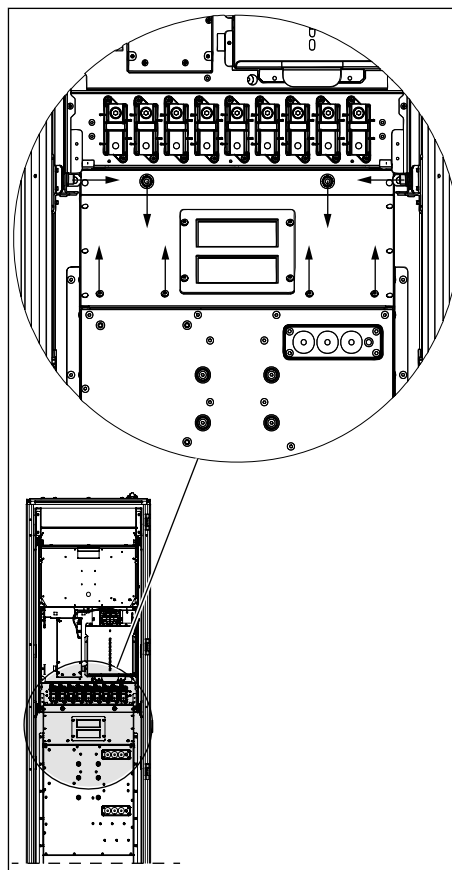

- 5 Pull the power unit out carefully until it is possible to re-attach the lifting lugs.

- 6 Re-attach the lifting lugs. You can use the extra nut that is on the screw. Remove the nut and attach it to the other side of the lifting lug.

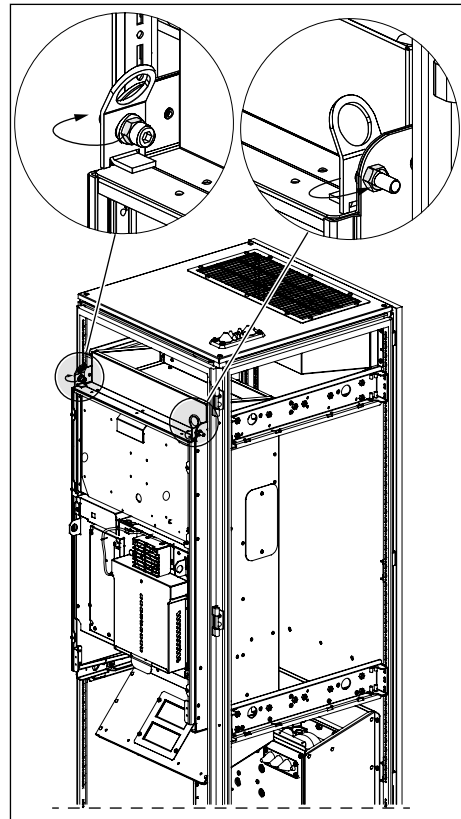

- 7 Attach the lifting hooks to the lifting lugs and lift the power unit out of the cabinet.

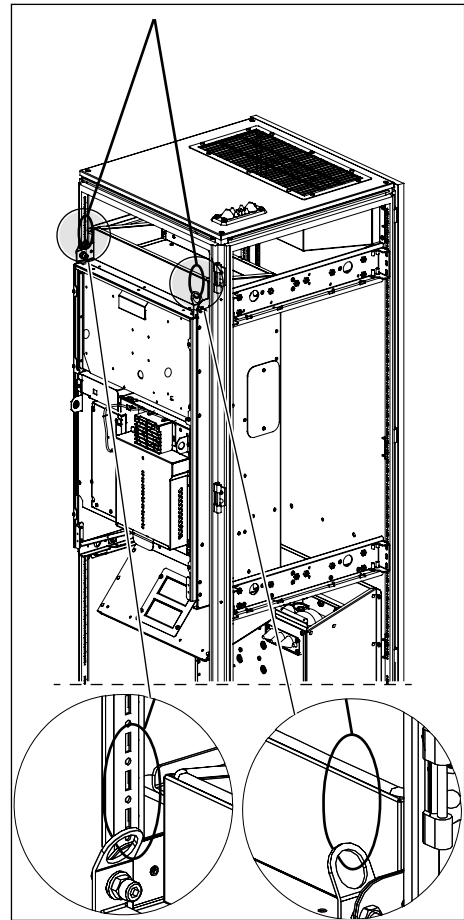

7.6.4.3 Replacing the power unit, MR10 and MR12

- 1 Remove the protective covers of the drive.

- In MR12, do these steps for each cabinet.

- 2 Remove the 4 screws of the lower cover of the power unit and remove the cover.

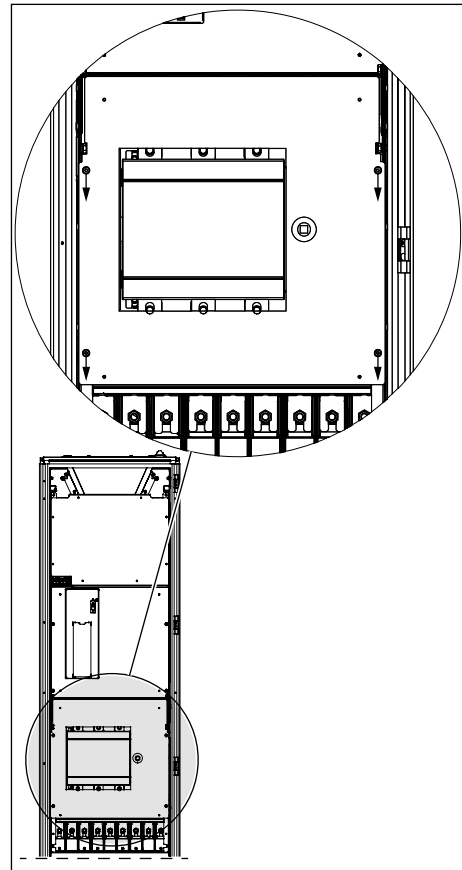

- 3 Disconnect all the power cables from the bottom of the power unit.
- 4 Remove the 2 screws from the top of the power unit.

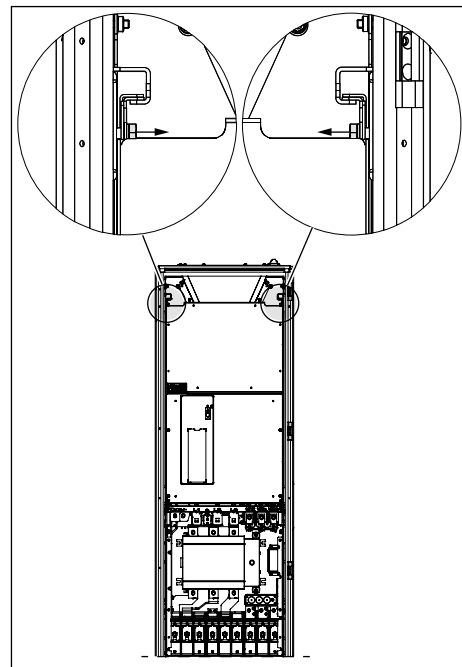

- 5 Remove the 2 screws from the bottom of the power unit.

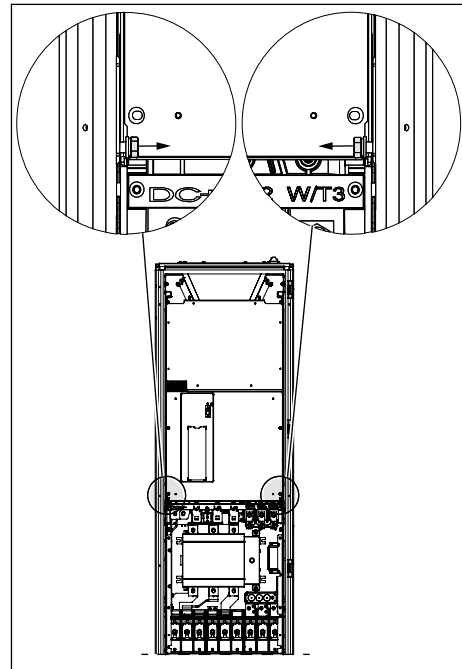

- 6 Pull the power unit out carefully until the front lifting holes are available.
- 7 Attach the lifting hooks to the front lifting holes and lift the power unit out of the cabinet.

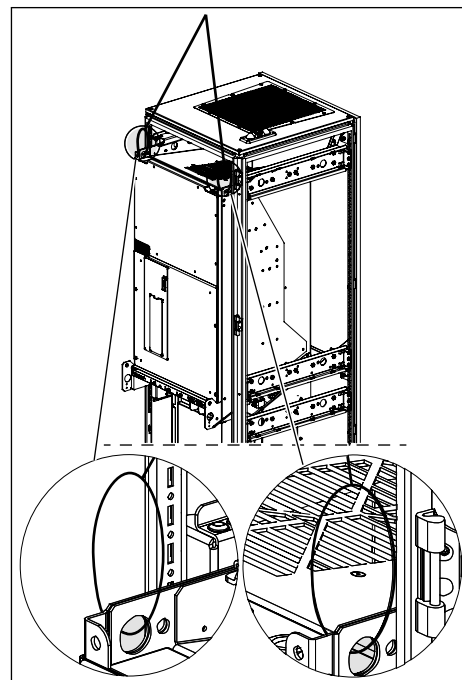

7.6.5 DOWNLOADING THE SOFTWARE

When it is necessary to get a new version of the software of the drive, obey these instructions. For more information, speak to the manufacturer.

Before you start to download the software, read these warnings and the warnings in Chapter 2 *Safety*.

**WARNING!**

Do not touch the internal components or the circuit boards of the drive when the drive is connected to mains. These components are live. A contact with this voltage is very dangerous.

**WARNING!**

Do not make connections to or from the AC drive when it is connected to mains. There is a dangerous voltage.

**WARNING!**

To do work on the connections of the drive, disconnect the drive from mains. Wait 5 minutes before you open the cabinet door or the cover of the drive. Then use a measuring device to make sure that there is no voltage. The connections of the drive are live 5 minutes after it is disconnected from mains.

**WARNING!**

Before you do electrical work, make sure that there is no voltage.

DOWNLOADING WITH MAINS, MR8-MR12

When the drive is supplied from mains, you can download a new software with the Vacon Loader PC tool and a CAB-USB/RS485 cable.

- 1 To download a new software, connect the PC into the control panel connector with the CAB-USB/RS485 cable.
 - The downloading time:
 - MR8 and MR9: approximately 6 minutes
 - MR10: approximately 12 minutes
 - MR12: approximately 25 minutes

When the drive is not supplied from mains, there are 2 alternatives to download the software.

1. The first is to use the Software Service Kit. The kit enables the power-up of the control board without the power-up of the drive, and enables you to download the software. Refer to the Software Service Kit User Manual for more information. In MR10 and MR12, you must also connect an external 24 VDC into the connector X50 on the measurement board.
2. The second alternative is to use an external 24 VDC power supply. Refer to the instructions below.

DOWNLOADING WITHOUT MAINS, MR8-MR12

When the drive is not supplied from mains, use an external 24 VDC power supply to do power-up to the control unit. In MR8 and MR9, the external 24 VDC does power up to the control unit, and in MR10 and MR12, it does power up to the control unit and the measurement board(s). After the power-up you can download the software.

The requirements for the 24 VDC power supply:

- A voltage accuracy +/-10%
 - MR8-MR9: > 1000 mA
 - MR10: > 2000 mA
 - MR12: > 4000 mA
- 1 In MR8 and MR9, connect an external 24 VDC power supply into the control terminals 13 and 30. Connect the external GND potential into terminal 13, and the external 24 VDC (+) potential into terminal 30. See the terminals in *Fig. 29* and *Fig. 30*.
 - 2 In MR10 and MR12, loosen the screws of the service lid and remove it.
 - In MR12, there are two power units. Do the steps 2 and 3 for the two power units.

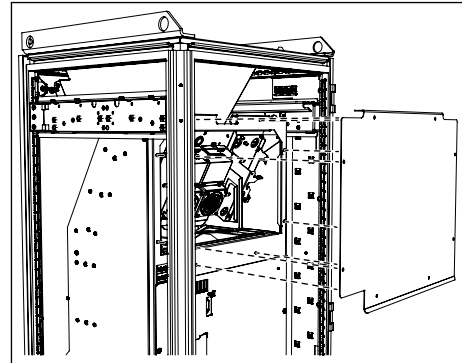

- 3 In MR10 and MR12, connect an external 24 VDC into the connector X50 on the measurement board. The connector pins are X50-22 (+) and X50-23 (-).
 - In MR12, connect the external 24 VDC to the two X50 connectors.

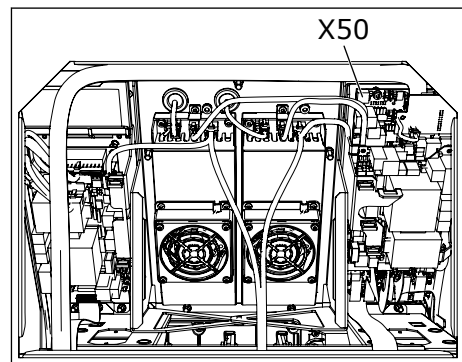

i **NOTE!**

The size of the power supply wire for the external 24 VDC must be a minimum of 1 mm². The length of the wire from the 24 VDC power supply to the X50 connectors and to the control unit connectors must be a maximum of 3 m.

- 4 In all the frame sizes, do power-up to the external 24 VDC power supply.
- 5 Remove the control panel. Connect the PC to the control panel connector in the control unit with an CAB-USB/RS485 cable.
- 6 Start the Vacon Loader PC tool.
- 7 Start the downloading of the software.
- 8 After the downloading is complete, disconnect the PC and attach the control panel into the control unit.
- 9 Do power-down to the external 24 VDC power supply.

- 10 In MR8 and MR9, remove the external 24 VDC power supply wires from the terminals. (Unless the control unit of the drive is normally supplied with an external 24 VDC supply.)
- 11 In MR10 and MR12, remove the external 24 VDC wires from the X50 connector of the measurement board. In MR12, there are two X50 connectors.
- 12 In MR10 and MR12, attach the service lid. In MR12, there are two service lids.
- 13 After the downloading procedure is complete, start the Startup wizard (see the Application Manual).

**WARNING!**

Before you connect the drive to mains, make sure that the front cover and the cable cover of the drive are closed. The connections of the AC drive are live when the drive is connected to mains.

8 TECHNICAL DATA, VACON® 100

8.1 AC DRIVE POWER RATINGS

8.1.1 MAINS VOLTAGE 380-500 V

Table 24: The power ratings of Vacon® 100 in mains voltage 380-500V, 50-60 Hz, 3~

Frame	Drive type	Loadability							Motor shaft power			
		Low			High			Max current Is 2s	400 V mains		480 V mains	
		Continuous current I _{Lout} [A]	Input current I _{Lin} [A]	10% overload current [A]	Continuous current I _{Hout} [A]	Input current I _{Hin} [A]	50% overload current [A]		10% overload 40°C [kW]	50% overload 40°C [kW]	10% overload 40°C [hp]	50% overload 40°C [hp]
MR8	0140	140.0	139.4	154.0	105.0	109.0	157.5	210.0	75.0	44.0	100.0	75.0
	0170	170.0	166.5	187.0	140.0	139.4	210.0	280.0	90.0	75.0	125.0	100.0
	0205	205.0	199.6	225.5	170.0	166.5	255.0	340.0	110.0	90.0	150.0	125.0
MR9	0261	261.0	258.0	287.1	205.0	204.0	307.5	410.0	132.0	110.0	200.0	150.0
	0310	310.0	303.0	341.0	251.0	246.0	376.5	502.0	160.0	132.0	250.0	200.0
MR10	0385	385.0	385.0	423.5	310.0	311.0	445.0	620.0	200.0	160.0	300.0	250.0
	0460	460.0	460.0	506.0	385.0	391.0	577.5	770.0	250.0	200.0	350.0	300.0
	0520	520.0	520.0	572.0	460.0	459.0	690.0	920.0	250.0	250.0	450.0	350.0
	0590*	590.0	590.0	649.0	520.0	515.0	780.0	1040.0	315.0	250.0	500.0	450.0
MR12	0650	650.0	648.0	715.0	590.0	587.0	885.0	1180.0	355.0	315.0	500.0	500.0
	0730	730.0	724.0	803.0	650.0	642.0	975.0	1300.0	400.0	355.0	600.0	500.0
	0820	820.0	822.0	902.0	730.0	731.0	1095.0	1460.0	450.0	400.0	700.0	600.0
	0920	920.0	916.0	1012.0	820.0	815.0	1230.0	1640.0	500.0	450.0	800.0	700.0
	1040*	1040.0	1030.0	1144.0	920.0	908.0	1380.0	1840.0	560.0	500.0	900.0	800.0
	1180*	1180.0	1164.0	1298.0	920.0	908.0	1380.0	1840.0	630.0	500.0	1000.0	800.0

* = The maximum ambient temperature is 35°C with the du/dt filter option. These currents are not available when you have the options back channel cooling and du/dt filter (+CHCB and +PODU).

8.1.2 MAINS VOLTAGE 525-690 V

Table 25: The power ratings of Vacon® 100 in mains voltage 525-690 V, 50-60 Hz, 3~

Frame	Drive type	Loadability							Motor shaft power			
		Low			High			Max current I _s 2s	600 V mains		690 V mains	
		Continuous current I _{Lout} [A]	Input current I _{Lin} [A]	10% overload current [A]	Continuous current I _{Hout} [A]	Input current I _{Hin} [A]	50% overload current [A]		10% overload 40°C [hp]	50% overload 40°C [hp]	10% overload 40°C [kW]	50% overload 40°C [kW]
MR8	0080	80.0	90.0	88.0	62.0	72.0	93.0	124.0	75.0	60.0	75.0	55.0
	0100	100.0	106.0	110.0	80.0	89.0	120.0	160.0	100.0	75.0	90.0	75.0
	0125	125.0	127.0	137.5	100.0	104.0	150.0	200.0	125.0	100.0	110.0	90.0
MR9	0144	144.0	156.0	158.4	125.0	140.0	187.5	250.0	150.0	125.0	132.0	110.0
	0170	170.0	179.0	187.0	144.0	155.0	216.0	288.0	-	-	160.0	132.0
	0208	208.0	212.0	228.8	170.0	177.0	255.0	340.0	200.0	150.0	200.0	160.0
MR10	0261	261.0	272.0	287.1	208.0	223.0	312.0	416.0	250.0	200.0	250.0	200.0
	0325	325.0	330.0	357.5	261.0	269.0	391.5	522.0	300.0	250.0	315.0	250.0
	0385	385.0	386.0	423.5	325.0	327.0	487.5	650.0	400.0	300.0	355.0	315.0
	0416*	416.0	415.0	457.6	385.0	382.0	577.5	770.0	450.0	300.0	400.0	355.0
MR12	0460	460.0	477.0	506.0	416.0	433.0	624.0	832.0	450.0	400.0	450.0	400.0
	0520	520.0	532.0	572.0	460.0	472.0	690.0	920.0	500.0	450.0	500.0	450.0
	0590	590.0	597.0	649.0	520.0	527.0	780.0	1040.0	600.0	500.0	560.0	500.0
	0650	650.0	653.0	715.0	590.0	591.0	885.0	1180.0	650.0	600.0	630.0	560.0
	0750*	750.0	747.0	825.0	650.0	646.0	975.0	1300.0	700.0	650.0	710.0	630.0
	0820*	820.0	813.0	902.0	650.0	739.0	975.0	1300.0	800.0	650.0	800.0	630.0

* = The maximum ambient temperature is 35°C with the du/dt filter option. These currents are not available when you have the options back channel cooling and du/dt filter (+CHCB and +PODU).

8.1.3 BRAKE RESISTOR RATINGS

Make sure that the resistance is higher than the set minimum resistance. The power handling capacity must be sufficient for the application.

Table 26: The recommended brake resistor types and the calculated resistance of the drive, 380-500 V

Frame	Duty cycle	Type of brake resistor	Resistance [Ω]
MR8	Light duty	BRR 0105 LD 5	6.5
	Heavy duty	BRR 0105 HD 5	6.5
MR9	Light duty	BRR 0300 LD 5	3.3
	Heavy duty	BRR 0300 HD 5	3.3
MR10	Light duty	BRR 0520 LD 5	1.4
	Heavy duty	BRR 0520 HD 5	1.4
MR12	Light duty	BRR 0520 LD 5	2 x 1.4
	Heavy duty	BRR 0520 LD 5	2 x 1.4

Table 27: The recommended brake resistor types and the calculated resistance of the drive, 525-690 V

Frame	Drive type	Duty cycle	Type of brake resistor	Resistance [Ω]
MR8	0080	Light duty	BRR 0052 LD 6	18
		Heavy duty	BRR 0052 HD 6	18
	0100-0125	Light duty	BRR 0100 LD 6	9
		Heavy duty	BRR 0100 HD 6	9
MR9	0144	Light duty	BRR 0100 LD 6	9
		Heavy duty	BRR 0100 HD 6	9
	0170-0208	Light duty	BRR 0208 LD 6	7
		Heavy duty	BRR 0208 HD 6	7
MR10	0261-0416	Light duty	BRR 0416 LD 6	2.5
		Heavy duty	BRR 0416 HD 6	2.5
MR12	0460-0820	Light duty	BRR 0416 LD 6	2 x 2.5
		Heavy duty	BRR 0416 HD 6	2 x 2.5

The frame MR12 includes 2 power units, each of which has a brake chopper. The brake choppers must have their own brake resistors. See *Fig. 27 The inside layout of MR12, without protective covers.*

- The light duty cycle is for brake resistor cyclic use (1 LD pulse in a 120-second period). The light duty resistor is rated for a 5-second ramp from full power to 0.
- The heavy duty cycle is for brake resistor cyclic use (1 HD pulse in a 120-second period). The heavy duty resistor is rated for a 3-second full power braking with a 7-second ramp to 0.

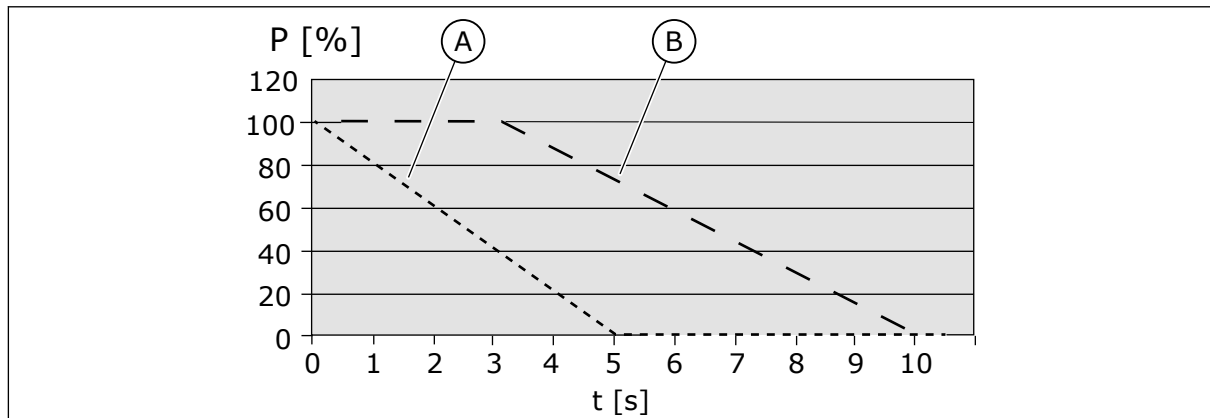

Fig. 31: The LD and HD pulses

A. Light duty

B. Heavy duty

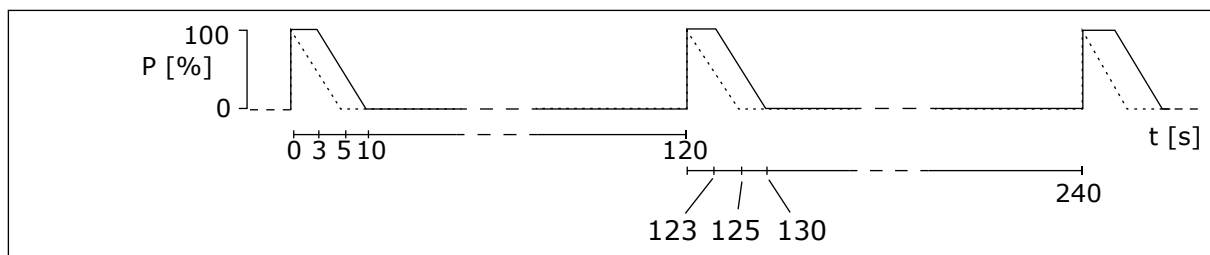

Fig. 32: The duty cycles of the LD and HD pulses

Table 28: The minimum resistance and the brake power, mains voltage 380-500 V

Frame	The minimum brake resistance [Ω]	Brake power* @845 VDC [kW]
MR8	6.5	109.9
MR9	3.3	216.4
MR10	1.4	400
MR12	2 x 1.4 **	800

Table 29: The minimum resistance and the brake power, mains voltage 525-690 V

Frame	The minimum brake resistance [Ω]	Brake power* @1166 VDC [kW]
MR8	9	110
MR9	7	193
MR10	2.5	400
MR12	2 x 2.5 **	800

* = When you use recommended resistor types.

** = The MR12 must have 2 brake resistors.

8.2 VACON® 100 - TECHNICAL DATA

Table 30: The technical data of the Vacon® 100 AC drive

Technical item or function	Technical data	
Mains connection	Input voltage U_{in}	380-500 V, 525-690 V, -10%...+10%
	Input frequency	50-60 Hz, -5...+10%
	Connection to mains	Once per minute or less frequently
	Starting delay	8 s (MR8 to MR12)
	Mains	<ul style="list-style-type: none"> Mains types: TN, TT, and IT Short circuit current: the maximum short circuit current must be < I_{cc} 65 kA.
Motor connection	Output voltage	0- U_{in}
	Continuous output current	IL: Ambient temperature max. +40 °C overload 1.1 x IL (1 min/10 min) IH: Ambient temperature max. +40 °C overload 1.5 x IH (1 min/10 min) IH in 690 V drives: Ambient temperature max. +40 °C overload 1.5 x IH (1 min/10 min)
	Output frequency	0-320 Hz (standard)
	Frequency resolution	0.01 Hz

Table 30: The technical data of the Vacon® 100 AC drive

Technical item or function	Technical data
Control characteristics	<p>Switching frequency (see parameter P3.1.2.3)</p> <p>380-500 V</p> <ul style="list-style-type: none"> • MR8-MR12: <ul style="list-style-type: none"> • 1.5-6 kHz • Default: MR8: 3 kHz, MR9: 2 kHz, MR10: 2 kHz, MR12: 2 kHz <p>525-690 V</p> <ul style="list-style-type: none"> • MR8-MR12: <ul style="list-style-type: none"> • 1.5-6 kHz • Default: 2 kHz • For a product that is configured for a C4 installation on IT network the maximum switching frequency is limited to default 2kHz. <p>Automatic switching frequency derating in case of overload.</p>
Frequency reference: Analogue input Panel reference	Resolution 0.1% (10-bit), accuracy ±1% Resolution 0.01 Hz
Field weakening point	8-320 Hz
Acceleration time	0.1-3000 s
Deceleration time	0.1-3000 s

Table 30: The technical data of the Vacon® 100 AC drive

Technical item or function	Technical data
Ambient conditions	Ambient operating temperature IL current: -10°C (no frost)...+40 °C IH current: -10°C (no frost)...+40 °C Maximum operating temperature: +50 °C with derating (1.5%/1°C) Drives with safety-related options have a maximum ambient temperature of 40 °C.
	Storage temperature -40 °C...+70 °C
	Relative humidity 0-95% RH, non-condensing, non-corrosive
	Air quality Tested according to IEC 60068-2-60 Test Ke: Flowing mixed gas corrosion test, Method 1 (H ₂ S [hydrogen sulfide] and SO ₂ [sulfur dioxide]) Designed according to <ul style="list-style-type: none"> • Chemical vapours: IEC 60721-3-3, unit in operation, class 3C2 • Mechanical particles: IEC 60721-3-3, unit in operation, class 3S2
	Altitude 100% load capacity (no derating) up to 1000 m 1% derating for each 100m above 1000 m Maximum altitudes: <ul style="list-style-type: none"> • 380-500 V: 4000 m (TN and IT systems) • 380-500 V: 2000 m (corner-grounded network) • 525-690 V: 2000 m (TN and IT systems, no corner grounding) Voltage for relay outputs: <ul style="list-style-type: none"> • Up to 3000 m : Allowed up to 240 V • 3000-4000 m: Allowed up to 120 V Corner-grounding: <ul style="list-style-type: none"> • up to 2000 m only (Requires a change in the EMC level from C3 to C4, see 7.5 <i>Installation in an IT system</i>.)
Pollution degree IP21: PD2 IP54: PD3	

Table 30: The technical data of the Vacon® 100 AC drive

Technical item or function	Technical data	
Ambient conditions	Vibration: EN61800-5-1 EN60068-2-6	5-150 Hz Displacement amplitude 0.5 mm (peak) at 5-22 Hz Maximum acceleration amplitude 1 G at 22-150 Hz
	Shock: EN60068-2-27	UPS Drop Test (for applicable UPS weights) Storage and shipping: maximum 15 G, 11 ms (in package)
	Enclosure class	IP21: standard IP54: option
EMC (at default settings)	Immunity	Fulfills EN61800-3, 1st and 2nd environment
	Emissions	<ul style="list-style-type: none"> • 380-500 V: EN 61800-3 (2004), category C3, if the drive is correctly installed. • 525-690 V: EN 61800-3 (2004), category C3, if the drive is correctly installed. • All: The drive can be changed to C4 for IT type mains. See chapter 7.5 <i>Installation in an IT system</i>.
Noise level	Average noise level (min-max) sound pressure level in dB(A)	The sound pressure depends on the cooling fan speed, which is controlled in accordance with the drive temperature. MR8: 58-73 MR9: 54-75 MR10/MR12: 58-75
Safety		EN 61800-5-1, CE (See the nameplate of the drive for more approvals.)

Table 30: The technical data of the Vacon® 100 AC drive

Technical item or function		Technical data
Protections	Overvoltage trip limit	Mains voltage 500 V: 911 VDC Mains voltage 690 V: 1258 VDC
	Undervoltage trip limit	Depends on mains voltage (0.8775 x mains voltage): Mains voltage 400 V: trip limit 351 VDC Mains voltage 500 V: trip limit 438 VDC Mains voltage 525 V: trip limit 461 VDC Mains voltage 690 V: trip limit 606 VDC
	Earth fault protection	Yes
	Mains supervision	Yes
	Motor phase supervision	Yes
	Overcurrent protection	Yes
	Unit overtemperature protection	Yes
	Motor overload protection	Yes. The motor overload protection activates at 110% of the full load current.
	Motor stall protection	Yes
	Motor underload protection	Yes
	Short-circuit protection of +24 V and +10 V reference voltages	Yes

9 TECHNICAL DATA, VACON® 100 FLOW

9.1 AC DRIVE POWER RATINGS

9.1.1 MAINS VOLTAGE 380-500 V

Table 31: The power ratings of Vacon® 100 FLOW in mains voltage 380-500 V, 50-60 Hz, 3~

Frame	Drive type	Loadability				Motor shaft power	
		Continuous current I_{Lout} [A]	Input current I_{Lin} [A]	10% overload current [A]	Max current I_S 2s	400 V mains	480 V mains
						10% overload 40°C [kW]	10% overload 40°C [hp]
MR8	0140	140.0	139.4	154.0	210.0	75.0	100.0
	0170	170.0	166.5	187.0	280.0	90.0	125.0
	0205	205.0	199.6	225.5	340.0	110.0	150.0
MR9	0261	261.0	258.0	287.1	410.0	132.0	200.0
	0310	310.0	303.0	341.0	502.0	160.0	250.0
MR10	0385	385.0	385.0	423.5	620.0	200.0	300.0
	0460	460.0	460.0	506.0	770.0	250.0	350.0
	0520	520.0	520.0	572.0	920.0	250.0	450.0
	0590*	590.0	590.0	649.0	1040.0	315.0	500.0
MR12	0650	650.0	648.0	715.0	1180.0	355.0	500.0
	0730	730.0	724.0	803.0	1300.0	400.0	600.0
	0820	820.0	822.0	902.0	1460.0	450.0	700.0
	0920	920.0	916.0	1012.0	1640.0	500.0	800.0
	1040*	1040.0	1030.0	1144.0	1840.0	560.0	900.0
	1180*	1180.0	1164.0	1298.0	1840.0	630.0	1000.0

* = The maximum ambient temperature is 35°C with the du/dt filter option. These currents are not available when you have the options back channel cooling and du/dt filter (+CHCB and +PODU).

9.1.2 MAINS VOLTAGE 525-690 V

Table 32: The power ratings of Vacon® 100 FLOW in mains voltage 525-690 V, 50-60 Hz, 3~

Frame	Drive type	Loadability				Motor shaft power	
		Continuous current I_{Lout} [A]	Input current I_{Lin} [A]	10% overload current [A]	Max current I_S 2s	600 V mains	690 V mains
						10% overload 40°C [hp]	10% overload 40°C [kW]
MR8	0080	80.0	90.0	88.0	124.0	75.0	55.0
	0100	100.0	106.0	110.0	160.0	100.0	75.0
	0125	125.0	127.0	137.5	200.0	125.0	90.0
MR9	0144	144.0	156.0	158.4	250.0	150.0	110.0
	0170	170.0	179.0	187.0	288.0	-	132.0
	0208	208.0	212.0	228.8	340.0	200.0	160.0
MR10	0261	261.0	272.0	287.1	416.0	250.0	200.0
	0325	325.0	330.0	357.5	522.0	300.0	250.0
	0385	385.0	386.0	423.5	650.0	400.0	315.0
	0416*	416.0	415.0	457.6	770.0	450.0	355.0
MR12	0460	460.0	477.0	506.0	832.0	450.0	400.0
	0520	520.0	532.0	572.0	920.0	500.0	450.0
	0590	590.0	597.0	649.0	1040.0	600.0	500.0
	0650	650.0	653.0	715.0	1180.0	650.0	560.0
	0750*	750.0	747.0	825.0	1300.0	700.0	630.0
	0820*	820.0	813.0	902.0	1300.0	800.0	630.0

* = The maximum ambient temperature is 35°C with the du/dt filter option. These currents are not available when you have the options back channel cooling and du/dt filter (+CHCB and +PODU).

9.2 VACON® 100 FLOW - TECHNICAL DATA

Table 33: The technical data of the Vacon® 100 FLOW AC drive

Technical item or function		Technical data
Mains connection	Input voltage U_{in}	380-500 V, 525-690 V, -10%...+10%
	Input frequency	50-60 Hz, -5...+10%
	Connection to mains	Once per minute or less frequently
	Starting delay	8 s (MR8 to MR12)
	Mains	<ul style="list-style-type: none"> • Mains types: TN, TT, and IT • Short circuit current: the maximum short circuit current must be < I_{cc} 65 kA.
Motor connection	Output voltage	0- U_{in}
	Continuous output current	I_L : Ambient temperature max. +40 °C overload 1.1 x I_L (1 min/10 min)
	Output frequency	0-320 Hz (standard)
	Frequency resolution	0.01 Hz

Table 33: The technical data of the Vacon® 100 FLOW AC drive

Technical item or function	Technical data
Control qualities	<p>Switching frequency (see parameter P3.1.2.3)</p> <p>380-500 V</p> <ul style="list-style-type: none"> • MR8-MR12: <ul style="list-style-type: none"> • 1.5-6 kHz • Default: MR8: 3 kHz, MR9: 2 kHz, MR10: 2 kHz, MR12: 2 kHz <p>525-690 V</p> <ul style="list-style-type: none"> • MR8-MR12: <ul style="list-style-type: none"> • 1.5-6 kHz • Default: 2 kHz • For a product that is configured for a C4 installation on IT network the maximum switching frequency is limited to default 2kHz. <p>Automatic switching frequency derating in case of overload.</p>
Frequency reference: Analogue input Panel reference	Resolution 0.1% (10-bit), accuracy ±1% Resolution 0.01 Hz
Field weakening point	8-320 Hz
Acceleration time	0.1-3000 s
Deceleration time	0.1-3000 s

Table 33: The technical data of the Vacon® 100 FLOW AC drive

Technical item or function	Technical data
Ambient conditions	Ambient operating temperature IL current: -10°C (no frost)...+40 °C Maximum operating temperature: +50 °C with derating (1.5%/1°C) Drives with safety-related options have a maximum ambient temperature of 40 °C.
	Storage temperature -40 °C...+70 °C
	Relative humidity 0-95% RH, non-condensing, non-corrosive
	Air quality Tested according to IEC 60068-2-60 Test Ke: Flowing mixed gas corrosion test, Method 1 (H ₂ S [hydrogen sulfide] and SO ₂ [sulfur dioxide]) Designed according to <ul style="list-style-type: none"> • Chemical vapours: IEC 60721-3-3, unit in operation, class 3C2 • Mechanical particles: IEC 60721-3-3, unit in operation, class 3S2
	Altitude 100% load capacity (no derating) up to 1000 m 1-% derating for each 100m above 1000 m Maximum altitudes: <ul style="list-style-type: none"> • 380-500 V: 4000 m (TN and IT systems) • 380-500 V: 2000 m (corner-grounded network) • 525-690 V: 2000 m (TN and IT systems, no corner grounding) Voltage for relay outputs: <ul style="list-style-type: none"> • Up to 3000 m : Allowed up to 240 V • 3000-4000 m: Allowed up to 120 V Corner-grounding: <ul style="list-style-type: none"> • up to 2000 m only (Requires a change in the EMC level from C3 to C4, see 7.5 <i>Installation in an IT system</i>.)
Pollution degree	IP21: PD2 IP54: PD3

Table 33: The technical data of the Vacon® 100 FLOW AC drive

Technical item or function	Technical data	
Ambient conditions	Vibration: EN61800-5-1 EN60068-2-6	5-150 Hz Displacement amplitude 0.5 mm (peak) at 5-22 Hz Maximum acceleration amplitude 1 G at 22-150 Hz
	Shock: EN60068-2-27	UPS Drop Test (for applicable UPS weights) Storage and shipping: maximum 15 G, 11 ms (in package)
	Enclosure class	IP21: standard IP54: option
EMC (at default settings)	Immunity	Fulfils EN61800-3, 1st and 2nd environment
	Emissions	<ul style="list-style-type: none"> • 380-500 V: EN 61800-3 (2004), category C3, if the drive is correctly installed. • 525-690 V: EN 61800-3 (2004), category C3, if the drive is correctly installed. • All: The drive can be changed to C4 for IT type mains. See chapter 7.5 <i>Installation in an IT system</i>.
Noise level	Average noise level (min-max) sound pressure level in dB(A)	The sound pressure depends on the cooling fan speed, which is controlled in accordance with the drive temperature. MR8: 58-73 MR9: 54-75 MR10/MR12: 58-75
Safety		EN 61800-5-1, CE (See the nameplate of the drive for more approvals.)

Table 33: The technical data of the Vacon® 100 FLOW AC drive

Technical item or function		Technical data
Protections	Overvoltage trip limit	Mains voltage 500 V: 911 VDC Mains voltage 690 V: 1258 VDC
	Undervoltage trip limit	Depends on mains voltage (0.8775 x mains voltage): Mains voltage 400 V: trip limit 351 VDC Mains voltage 500 V: trip limit 438 VDC Mains voltage 525 V: trip limit 461 VDC Mains voltage 690 V: trip limit 606 VDC
	Earth fault protection	Yes
	Mains supervision	Yes
	Motor phase supervision	Yes
	Overcurrent protection	Yes
	Unit overtemperature protection	Yes
	Motor overload protection	Yes. The motor overload protection activates at 110% of the full load current.
	Motor stall protection	Yes
	Motor underload protection	Yes
	Short-circuit protection of +24 V and +10 V reference voltages	Yes

10 TECHNICAL DATA ON CONTROL CONNECTIONS

10.1 TECHNICAL DATA ON CONTROL CONNECTIONS

Table 34: The standard I/O board

Standard I/O board		
Terminal	Signal	Technical information
1	Reference output	+10 V, +3%, maximum current: 10 mA
2	Analogue input, voltage or current	Analogue input channel 1 0...+10 V (Ri = 200 kΩ) 4-20 mA (Ri =250 Ω) Resolution 0.1 %, accuracy ±1 % Selection V/mA with DIP switches (see chapter Selection of terminal functions with DIP switches in the Installation Manual).
3	Analogue input common (current)	Differential input if not connected to ground Allows ±20 V common mode voltage to GND
4	Analogue input, voltage or current	Analogue input channel 2 Default: 4-20 mA (Ri =250 Ω) 0-10 V (Ri=200 kΩ) Resolution 0.1 %, accuracy ±1 % Selection V/mA with DIP switches (see chapter Selection of terminal functions with DIP switches in the Installation Manual)
5	Analogue input common (current)	Differential input if not connected to ground Allows ±20 V common mode voltage to GND
6	24 V aux. voltage	+24 V, ±10%, max volt. ripple < 100 mVrms max. 250 mA Short-circuit protected
7	I/O ground	Ground for reference and controls (connected internally to frame ground through 1 MΩ)
8	Digital input 1	Positive or negative logic Ri = min. 5 kΩ 0-5 V = 0 15-30 V = 1
9	Digital input 2	
10	Digital input 3	

Table 34: The standard I/O board

Standard I/O board		
Terminal	Signal	Technical information
11	Common A for DIN1-DIN6	Digital inputs can be disconnected from ground, see chapter Isolation of digital inputs from ground in the Installation Manual.
12	24 V aux. voltage	+24 V, $\pm 10\%$, max volt. ripple < 100mVrms max. 250 mA Short-circuit protected
13	I/O ground	Ground for reference and controls (connected internally to frame ground through 1 M Ω)
14	Digital input 4	Positive or negative logic R _i = min. 5 k Ω 0-5 V = 0 15-30 V = 1
15	Digital input 5	
16	Digital input 6	
17	Common A for DIN1-DIN6	Digital inputs can be isolated from ground, see chapter Isolation of digital inputs from ground in the Installation Manual.
18	Analogue signal (+output)	Analogue output channel 1, selection 0 -20 mA, load <500 Ω Default: 0-20 mA 0-10 V Resolution 0.1 %, accuracy ± 2 % Selection V/mA with DIP switches (see chapter Selection of terminal functions with DIP switches in the Installation Manual) Short-circuit protected
19	Analogue output common	
30	24V auxiliary input voltage	Can be used as external power backup for the control unit
A	RS485	Differential receiver/transmitter Set bus termination with DIP switches (see chapter Selection of terminal functions with DIP switches in the Installation Manual). Termination resistance = 220 Ω
B	RS485	

Table 35: The standard relay board (+SBF3)

Terminal	Signal	Technical information
21	Relay output 1 *	Change-over contact (SPDT) relay. 5.5 mm isolation between channels. Switching capacity <ul style="list-style-type: none"> • 24 VDC/8 A • 250 VAC/8 A • 125 VDC/0.4 A Minimum switching load <ul style="list-style-type: none"> • 5 V/10 mA
22		
23		
24	Relay output 2 *	Change-over contact (SPDT) relay. 5.5 mm isolation between channels. Switching capacity <ul style="list-style-type: none"> • 24 VDC/8 A • 250 VAC/8 A • 125 VDC/0.4 A Minimum switching load <ul style="list-style-type: none"> • 5 V/10 mA
25		
26		
32	Relay output 3 *	Normally-open (NO or SPST) contact relay. 5.5 mm isolation between channels. Switching capacity <ul style="list-style-type: none"> • 24 VDC/8 A • 250 VAC/8 A • 125 VDC/0.4 A Minimum switching load <ul style="list-style-type: none"> • 5 V/10 mA
33		

* = If you use 230 VAC as control voltage from the output relays, the control circuitry must be powered with a separate isolation transformer to limit the short circuit current and the overvoltage spikes. This is to prevent welding on the relay contacts. Refer to standard EN 60204-1, section 7.2.9.

Table 36: The optional relay board (+SBF4)

Terminal	Signal	Technical information
21	Relay output 1 *	Change-over contact (SPDT) relay. 5.5 mm isolation between channels. Switching capacity <ul style="list-style-type: none"> • 24 VDC/8 A • 250 VAC/8 A • 125 VDC/0.4 A Minimum switching load <ul style="list-style-type: none"> • 5 V/10 mA
22		
23		
24	Relay output 2 *	Change-over contact (SPDT) relay. 5.5 mm isolation between channels. Switching capacity <ul style="list-style-type: none"> • 24 VDC/8 A • 250 VAC/8 A • 125 VDC/0.4 A Minimum switching load <ul style="list-style-type: none"> • 5 V/10 mA
25		
26		
28	TI1+ TI1-	Thermistor input Rtrip = 4.7 kΩ (PTC) Measuring voltage 3.5V
29		

* = If you use 230 VAC as control voltage from the output relays, the control circuitry must be powered with a separate isolation transformer to limit the short circuit current and the overvoltage spikes. This is to prevent welding on the relay contacts. Refer to standard EN 60204-1, section 7.2.9.

VACON®

www.danfoss.com

Vacon Ltd
Member of the Danfoss Group
Runsorintie 7
65380 Vaasa
Finland

Document ID:



Rev. B

Sales code: DOC-INS100ED+DLUK