

VACON[®] 100 INDUSTRIAL
VACON[®] 100 FLOW
AC DRIVES

INSTALLATION MANUAL
ENCLOSED DRIVES

PREFACE

DOCUMENT DETAILS

Document ID: DPD01666E

Date: 27.03.2019

ABOUT THIS MANUAL

This manual is copyright of VACON Ltd. All Rights Reserved. The manual is subject to change without prior notice. The language of the original instructions is English.

ABOUT THE PRODUCT

This manual describes the VACON® 100 Enclosed Drive. The power range of the drive is between 75-800 kW, and its voltage range is 380-500 V or 525-690 V. The drive comes installed in a cabinet, and is available in 4 different enclosure sizes: MR8, MR9, MR10, MR11 and MR12. The drive can include 1 or more cabinets.

The drive is available in 2 regional versions: IEC (qualified to the IEC criteria) or NAM (qualified to the UL criteria).



Fig. 1: An example of the VACON® 100 Enclosed Drive

TABLE OF CONTENTS

Preface

Document details	3
About this manual	3
About the product	3
1 Approvals	7
2 Safety	8
2.1 The safety symbols used in the manual and the drive	8
2.2 Warning	8
2.3 Caution	9
2.4 Grounding and earth fault protection	10
2.5 Using an RCD or an RCM device	11
3 Receiving the delivery	13
3.1 Package label	13
3.2 Type designation code	14
3.3 The contents of the delivery	14
3.4 Storage	14
3.5 Removing the packaging and lifting the AC drive	15
3.5.1 Weight of the AC drive	15
3.5.2 Lifting the AC drive	15
3.6 "Product modified" label	17
3.7 Disposal	18
3.8 Accessories	18
3.8.1 The MR cabinet accessories bag	18
3.8.2 The MR10 accessories bag	18
4 Mounting	20
4.1 Dimensions of the cabinet, IEC	20
4.2 Dimensions of the cabinet with additional cabinet sections, IEC	22
4.3 Dimensions of the cabinet, NAM	27
4.4 Dimensions of the cabinet, with additional cabinet sections, NAM	31
4.5 The options	36
4.6 Installation of the cabinet	45
4.7 Cooling and free space around the AC drive	46
4.8 The optional back channel cooling	49
4.8.1 Using the back channel for cooling	50
5 Power cabling	53
5.1 Cable dimensioning and selection	53
5.1.1 Main circuit diagrams of the cabinet	53
5.1.2 Cables and fuses	55
5.1.3 Cable and fuse sizes, IEC	55
5.1.4 Cable and fuse sizes, North America	64
5.2 Brake resistor cables	69

5.3	Preparing for the cable installation	71
5.4	Cable installation in MR8-MR12	72
5.4.1	Installing the cables	77
6	Control compartment	83
6.1	The control compartment of the enclosed drive	83
6.2	Fieldbus connection	88
6.2.1	Internal fieldbuses in VACON® 100 products	88
6.2.2	General cabling instructions for fieldbus	89
6.2.3	Ethernet commissioning and cabling	92
6.2.4	RS485 commissioning and cabling	94
6.3	Installation of option boards	98
6.3.1	The installation procedure	100
6.4	Installation of a battery for the Real Time Clock (RTC)	101
7	Commissioning and additional instructions	103
7.1	Commissioning safety	103
7.2	Operation of the motor	104
7.2.1	Checks before starting the motor	104
7.3	Measuring the cable and motor insulation	104
7.4	Installation in a marine environment	104
7.5	Installation in a corner-grounded network	105
7.6	Installation in an IT system	105
7.6.1	The EMC jumper in MR8	105
7.6.2	The EMC jumper in MR9 and MR11	106
7.6.3	The EMC jumper in MR10 and MR12	111
7.7	Maintenance	112
7.7.1	Maintenance intervals	112
7.7.2	Replacing the air filters of the AC drive	113
7.7.3	Replacing the fans of the AC drive	114
7.7.4	Replacing the power unit of the AC drive	121
7.7.5	Downloading the software	131
8	Technical data, VACON® 100 INDUSTRIAL	135
8.1	AC drive power ratings	135
8.1.1	Mains voltage 380-500 V	135
8.1.2	Mains voltage 525-690 V	136
8.1.3	Brake resistor ratings	137
8.2	VACON® 100 INDUSTRIAL - technical data	141
9	Technical data, VACON® 100 FLOW	146
9.1	AC drive power ratings	146
9.1.1	Mains voltage 380-500 V	146
9.1.2	Mains voltage 525-690 V	147
9.2	VACON® 100 FLOW - technical data	148
10	Technical data on control connections	153
10.1	Technical data on control connections	153

1 APPROVALS

Here are the approvals that have been granted to this VACON® product.

1. EU Declaration of conformity
2. UL approval *
 - cULus approval file number E171278.

* The UL approval is valid for input voltage up to 600 V.





2 SAFETY

2.1 THE SAFETY SYMBOLS USED IN THE MANUAL AND THE DRIVE

This manual contains warnings and cautions, which are identified with safety symbols. The warnings and cautions give important information on how to prevent injury and damage to the equipment or your system.

Read the warnings and cautions carefully and obey their instructions.

Table 1: The safety symbols

The safety symbol	The safety word	Description
	WARNING!	If you do not obey the instructions, injury or death is possible.
	CAUTION!	If you do not obey the instructions, damage to the equipment is possible.
	HOT SURFACE!	If you do not obey the instructions, burns are possible.
	READ THE MANUAL!	You must read the manual.
	WAIT 5 MINUTES!	You must wait 5 minutes.

2.2 WARNING



WARNING!

Do not touch the components of the power unit when the drive is connected to mains. The components are live when the drive is connected to mains. A contact with this voltage is very dangerous.

**WARNING!**

Do not touch the motor cable terminals U, V, W, the brake resistor terminals or the DC terminals when the drive is connected to mains. These terminals are live when the drive is connected to mains, also when the motor does not operate.

**WARNING!**

Do not touch the control terminals. They can have a dangerous voltage also when the drive is disconnected from mains.

**WARNING!**

Before you do electrical work on the drive, disconnect the drive from the mains and make sure that the motor has stopped. Lock out and tag out the power source to the drive. Make sure that no external source generates unintended voltage during work. Note that also the load side of the drive can generate voltage. Wait 5 minutes before you open the cabinet door or the cover of the AC drive. Use a measuring device to make sure that there is no voltage. The terminal connections and the components of the drive can be live 5 minutes after it is disconnected from the mains and the motor has stopped.

**WARNING!**

Before you connect the drive to mains, make sure that the front cover and the cable cover of the drive are closed. The connections of the AC drive are live when the drive is connected to mains.

**WARNING!**

Disconnect the motor from the drive if an accidental start can be dangerous. When there is a power-up, a power break or a fault reset, the motor starts immediately if the start signal is active, unless the pulse control for Start/Stop logic is selected. If the parameters, the applications or the software change, the I/O functions (including the start inputs) can change.

**WARNING!**

Wear protective gloves when you do mounting, cabling or maintenance operations. There can be sharp edges in the AC drive that can cause cuts.

2.3 CAUTION**CAUTION!**

Do not move the AC drive. Use a fixed installation to prevent damage to the drive.

**CAUTION!**

Do not make measurements when the AC drive is connected to mains. It can cause damage to the drive.

**CAUTION!**

Make sure that there is reinforced protective ground connection. It is mandatory, because the touch current of the AC drives is more than 3.5 mA AC (refer to EN 61800-5-1). See chapter 2.4 *Grounding and earth fault protection*.

**CAUTION!**

Do not use spare parts that are not from the manufacturer. Using other spare parts can cause damage to the drive.

**CAUTION!**

Do not touch the components on the circuit boards. Static voltage can cause damage to these components.

**CAUTION!**

Make sure that the EMC level of the AC drive is correct for your mains. See chapter 7.6 *Installation in an IT system*. An incorrect EMC level can cause damage to the drive.

If you use Corner-grounding, change the EMC level to C4, see chapter 7.6 *Installation in an IT system*.

For information on permitted drive types for Corner-grounding, see chapter 7.5 *Installation in a corner-grounded network*.

**CAUTION!**

Prevent radio interference. The AC drive can cause radio interference in a domestic environment.

**NOTE!**

If you activate the autoreset function, the motor starts automatically after an automatic fault reset. See the Application Manual.

**NOTE!**

If you use the AC drive as a part of a machine, the machine manufacturer must supply a mains disconnection device (refer to EN 60204-1).

2.4 GROUNDING AND EARTH FAULT PROTECTION**CAUTION!**

The AC drive must always be grounded with a grounding conductor that is connected to the grounding terminal that is identified with the symbol \oplus . Not using a grounding conductor can cause damage to the drive.

The touch current of the drive is more than 3.5 mA AC. The standard EN 61800-5-1 tells that 1 or more of these conditions for the protective circuit must be true.

The connection must be fixed.

- a) The protective grounding conductor must have a cross-sectional area of minimum 10 mm² Cu or 16 mm² Al. OR
- b) There must be an automatic disconnection of the mains, if the protective grounding conductor breaks. See chapter 5 *Power cabling*. OR
- c) There must be a terminal for a second protective grounding conductor in the same cross-sectional area as the first protective grounding conductor.

Table 2: Protective grounding conductor cross-section

Cross-sectional area of the phase conductors (S) [mm ²]	The minimum cross-sectional area of the protective grounding conductor in question [mm ²]
$S \leq 16$	S
$16 < S \leq 35$	16
$35 < S$	S/2

The values of the table are valid only if the protective grounding conductor is made of the same metal as the phase conductors. If this is not so, the cross-sectional area of the protective grounding conductor must be determined in a manner that produces a conductance equivalent to that which results from the application of this table.

The cross-sectional area of each protective grounding conductor that is not a part of the mains cable or the cable enclosure, must be a minimum of:

- 2.5 mm² if there is mechanical protection, and
- 4 mm² if there is not mechanical protection. If you have cord-connected equipment, make sure that the protective grounding conductor in the cord is the last conductor to be interrupted, if the strain-relief mechanism breaks.

Obey the local regulations on the minimum size of the protective grounding conductor.

**NOTE!**

Because there are high capacitive currents in the AC drive, it is possible that the fault current protective switches do not operate correctly.

**CAUTION!**

Do not do voltage withstand tests on the AC drive. The manufacturer has already done the tests. Doing voltage withstand tests can cause damage to the drive.

2.5 USING AN RCD OR AN RCM DEVICE

The drive can cause a current in the protective grounding conductor. You can use a residual current-operated protective (RCD) device, or a residual current-operated monitoring (RCM) device to give protection against a direct or an indirect contact. Use a type B RCD or RCM device on the mains side of the drive.

NOTE! You can download the English and French product manuals with applicable safety, warning and caution information from <https://www.danfoss.com/en/service-and-support/>.

REMARQUE Vous pouvez télécharger les versions anglaise et française des manuels produit contenant l'ensemble des informations de sécurité, avertissements et mises en garde applicables sur le site <https://www.danfoss.com/en/service-and-support/>.

3 RECEIVING THE DELIVERY

Before a VACON® AC drive is sent to the customer, the manufacturer makes many tests on the drive to ensure its quality. When you receive the delivery, examine the packaging carefully. After you remove the packaging, examine the drive for transport damages.

If the drive was damaged during the shipping, speak to the cargo insurance company or the carrier.

To make sure that the contents of the delivery is correct and complete, compare the type designation of the product to the type designation code. See Chapter 3.2 *Type designation code*.

3.1 PACKAGE LABEL



Fig. 2: The package label of VACON® AC drives

- | | |
|------------------------------|-------------------------------------|
| A. The batch ID | F. The nominal output current |
| B. The VACON® order number | G. The IP class |
| C. The type designation code | H. The application code |
| D. The serial number | I. The order number of the customer |
| E. The mains voltage | |

3.2 TYPE DESIGNATION CODE

The type designation code is made of standard codes and option codes. Each part of the type designation code agrees to the data in your order. The code can have this format, for example:

VACON0100-3L-0385-5-ED-FLOW-R02+IP54

In chapter 4.5 *The options* you will find descriptions of the option codes.

Table 3: The description of the parts in the type designation code

Code	Description
VACON0100	The product family: VACON0100 = the VACON® 100 product family
3L	Input/Function: 3L = A 3-phase input
0385	The drive rating in amperes. For example, 0385 = 385 A
5	The mains voltage: 5 = 380-500 V 7 = 525-690 V
FLOW	The product: (empty) = The VACON® 100 INDUSTRIAL AC drive FLOW = The VACON® 100 FLOW AC drive
ED	The AC drive is enclosed in a cabinet
R02	The regional code: R02 = North American Market version (the product is qualified to the UL criteria)
+IP54	The option codes. There are many options, for example, +IP54 = an AC drive with the IP class IP54

You can find the type designation code on a label in the lower right corner of the control compartment door.

3.3 THE CONTENTS OF THE DELIVERY

The contents of the delivery, MR8-MR12

- The enclosed drive
- An accessories bag
- Installation Manual, Application Manual and manuals for the options that you ordered
- Order-specific documents (on the inside of the control compartment door)

3.4 STORAGE

The storage conditions

- Temperature: -40 °C...+70 °C
- Humidity: < 95%, no condensation

If you keep the package in storage for more than 2 months, keep it in controlled conditions. Make sure that the temperature variation is small and that the humidity is less than 50%.

3.5 REMOVING THE PACKAGING AND LIFTING THE AC DRIVE

3.5.1 WEIGHT OF THE AC DRIVE

The weights of AC drives of different enclosure sizes are very different. It can be necessary for you to use a lifting device to move the drive from its package.

Table 4: The default weight of the enclosed drive and some options

Enclosure size	The enclosed drive, IP21/IP54, without options [kg]	Common mode filter + du/dt filter [kg]	The sine filter [kg]	Any of the 3 cabling from top options [kg]
MR8	200	30	270	65
MR9	280	40	270	65
MR10	420	40	350	80
MR11	545	40	350	80
MR12	825	80	700	95

3.5.2 LIFTING THE AC DRIVE

The AC drive is delivered horizontally or vertically on a wooden pallet. Most enclosure sizes of the AC drive include additional cabinet sections when you order any of the 3 cabling from top options (+CHIT, +CHOT, or +CHCT), the input contactor (+CICO), or the sine filter (+COSI). The products are delivered with all the cabinets attached together, except for the MR12 if you order it with the +COSI option and/or the +CICO option.

MOVING THE ENCLOSED DRIVE

- 1 Do not remove the package material before you install the AC drive.
- 2 Put the drive onto a level base.
- 3 Move the drive in the vertical position.

- 4 Use a hoist to move the drive.

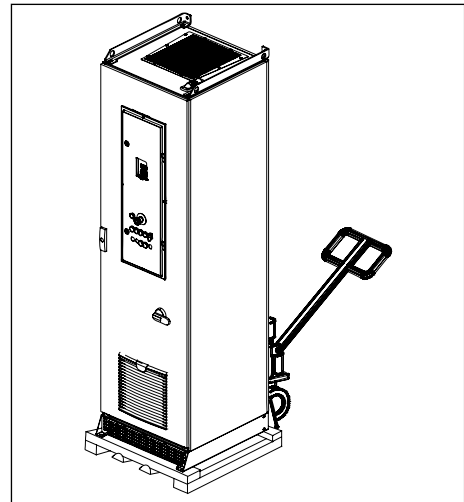

- 5 If you move more than 1 drive at a time, use rollers.

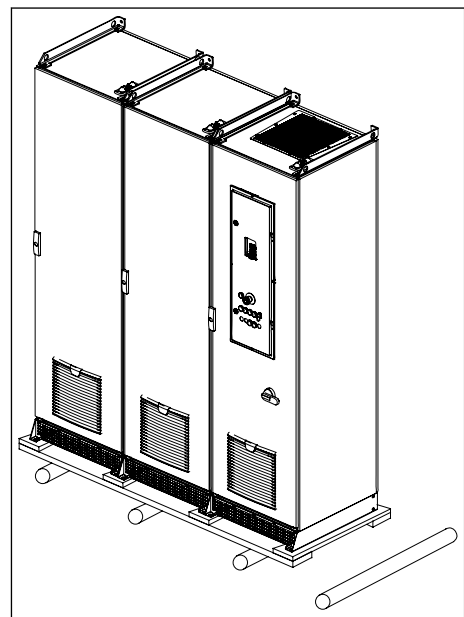

LIFTING THE ENCLOSED DRIVE

- 1 Remove the drive from the package.

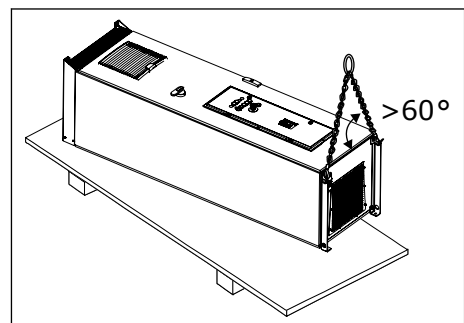

- 2 Use a lifting device that is sufficiently strong for the weight of the drive.
- 3 Put the lifting hooks in the holes on the top of the cabinet.

**CAUTION!**

To divide the weight of the AC drive equally, and to prevent damage to the equipment, always use 4 lifting holes.

- 4 The minimum angle between the drive and the chain is 60 degrees.
- 5 Lift the drive into a vertical position.

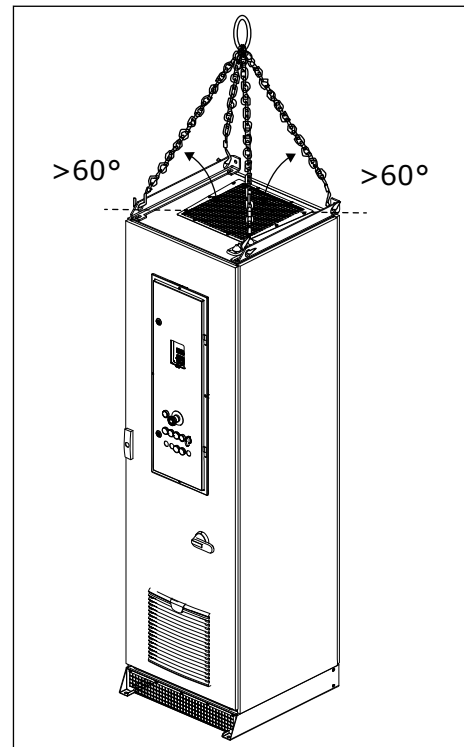

3.6 "PRODUCT MODIFIED" LABEL

In the accessories bag, there is also a "product modified" label. The function of the label is to tell the service personnel about the changes that are made in the AC drive. Attach the label on the side of the AC drive to know where to find it. If you make changes in the AC drive, write the change on the label.

<div style="border: 1px solid black; border-radius: 10px; padding: 5px; width: fit-content; margin: 0 auto;"> <p style="margin: 0;">Product modified</p> <p style="margin: 0;">Date:</p> <p style="margin: 0;">Date:</p> <p style="margin: 0;">Date:</p> </div>
--

3.7 DISPOSAL

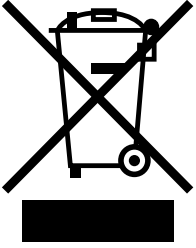
	<p>When the drive is at the end of its operation life, do not discard it as a part of municipal waste. You can recycle the primary components of the drive. You must disassemble some components before you can remove the different materials. Recycle the electrical and electronic components as waste.</p> <p>To make sure that the waste is recycled correctly, send the waste to a recycling centre. You can also send the waste back to the manufacturer.</p> <p>Obey the local and other applicable regulations.</p>
---	--

3.8 ACCESSORIES

After you open the package and lift out the drive, make sure that you received all the accessories. The contents of the accessories bag is different for different enclosure sizes and protection classes.

3.8.1 THE MR CABINET ACCESSORIES BAG

The MR cabinet accessories bag is included in the deliveries of all enclosure sizes.

Table 5: The contents of the accessories bag

Item	Quantity	Description
Grounding lamella	3	Grounding clamp for control cable
M4x16 screw	3	Screws for connecting the grounding clamp
Hose clamp	8	Clamps for IP54 sealing of cable grommets
Plinth fixing bracket	1	Drive cabinet fixing (back side)
"Product modified" label	1	Data about changes
M10x40 hexagon screw	6	Power cabling of enclosures MR8 and MR9
M10 conical washer nut	9	Power cabling of enclosures MR8 and MR9 frames
M10 sesko washer	15	Power cabling of enclosures MR8 and MR9

3.8.2 THE MR10 ACCESSORIES BAG

The MR10 accessories bag is included in the deliveries of enclosure sizes MR10 and MR12.

Table 6: The contents of the accessories bag

Item	Quantity	Description
Grounding lamella	3	Grounding clamp for control cable
M4x16 screw	3	Screws for connecting the grounding clamp
M8 hexagon nut	2	PE grounding
M8 conical spring washer	2	PE grounding
M8 sesko washer	2	PE grounding
"Product modified" label	1	Data about changes
Connector bolt Holder	9	Cabling with three wires
Connection brush	6	Cabling with three wires
M12x70 hexagon screw	9	Cabling with three wires
M12 conical spring washer	9	Cabling with three wires
M12 sesko washer	9	Cabling with three wires
M12 hexagon nut	9	Cabling with three wires

4 MOUNTING

4.1 DIMENSIONS OF THE CABINET, IEC

IEC = The product is qualified to the IEC criteria.
 NAM = The product is qualified to the UL criteria.

The information on dimensions that you will need in cabling can be found in the order-specific documents.



NOTE!

The height of the standard base plinth is 100 mm, but the height of the base plinth option (+CHPH) is 200 mm.

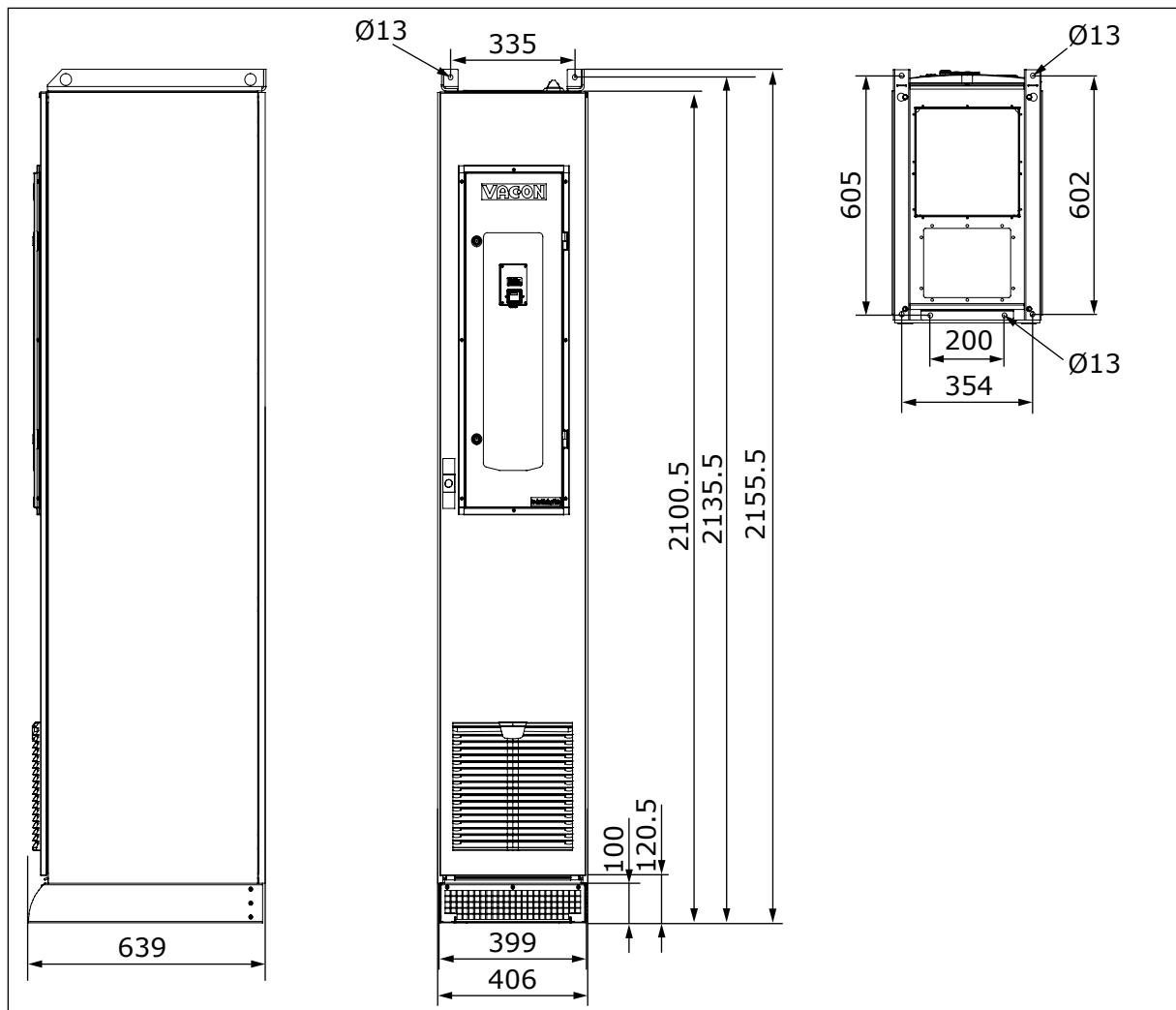

Fig. 3: The dimensions of the default cabinet, MR8, [mm], IEC

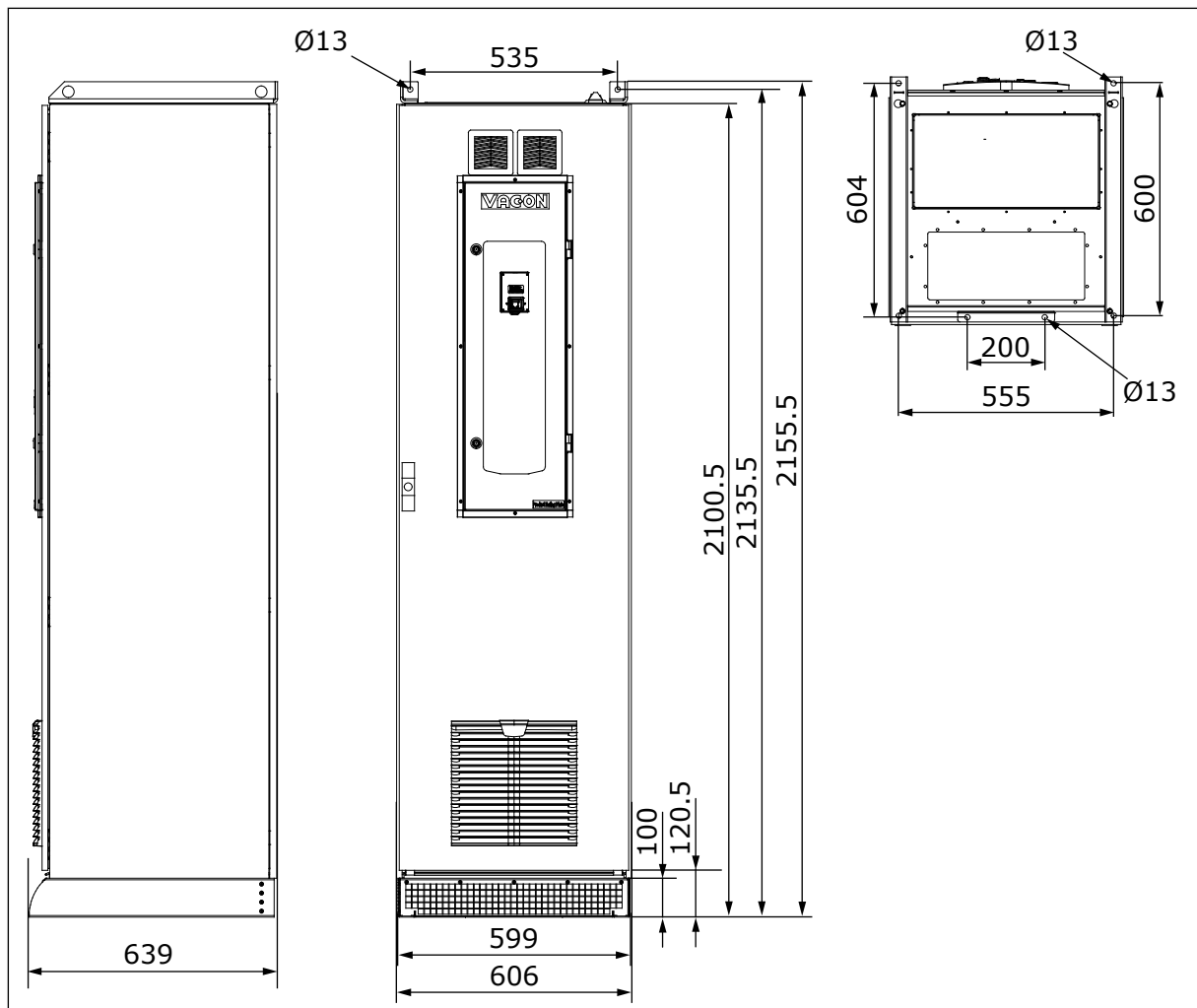

Fig. 4: The dimensions of the default cabinet, MR9 and MR10, [mm], IEC

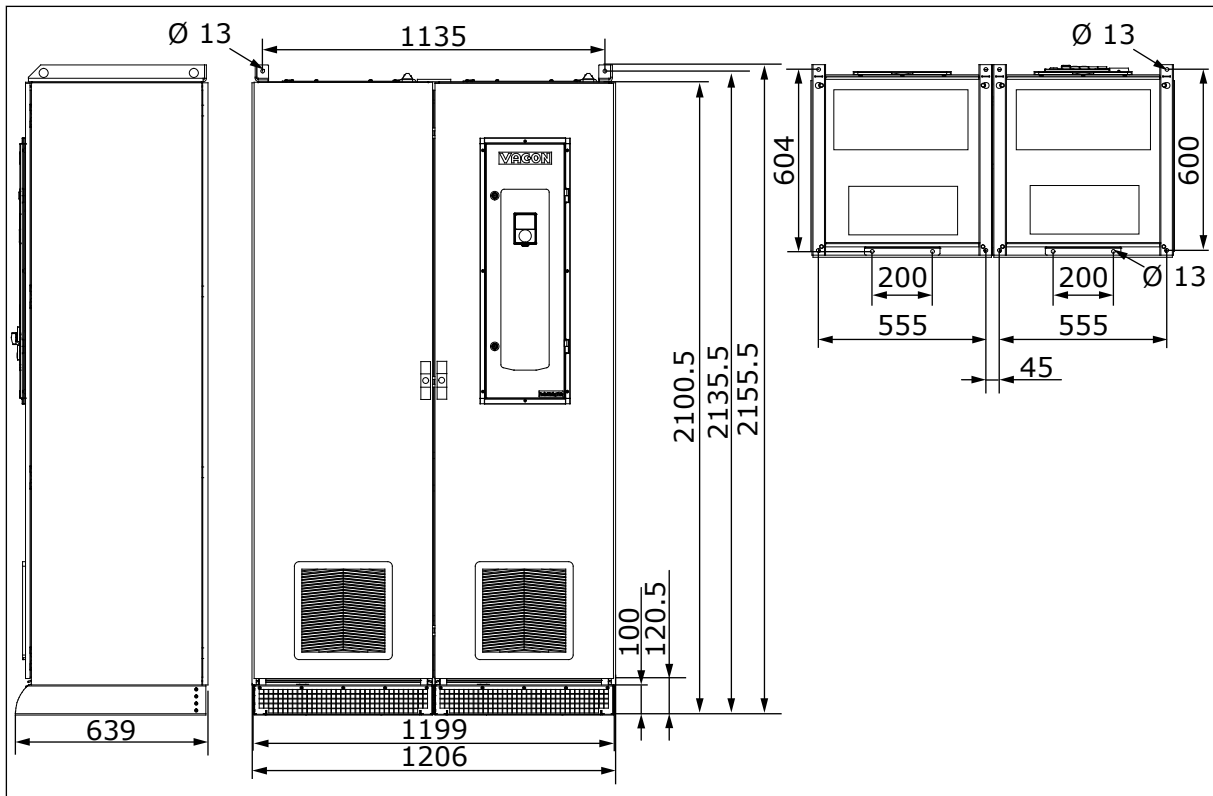

Fig. 5: The dimensions of the default cabinet, MR11 and MR12, [mm], IEC

4.2 DIMENSIONS OF THE CABINET WITH ADDITIONAL CABINET SECTIONS, IEC

IEC = The product is qualified to the IEC criteria.
 NAM = The product is qualified to the UL criteria.

The information on dimensions that you will need in cabling can be found in the order-specific documents.

Table 7: The width of the additional cabinet section [mm]

Enclosure size	With the input contactor (+CICO)	With +CHIT, +CHOT or +CHCT *	With +CICO and +CHIT, +CHOT or +CHCT *	With the sine filter (+COSI)
MR8	-	400	400	600
MR9	-	400	400	600
MR10, max 385 A	-	400	400	600
MR10, min 416 A	600	400	600	600
MR11	-	600	600	2 x 600
MR12, max. 750A	-	600	600	2 x 600
MR12, min. 820A	600	600	600	2 x 600

* = Input cabling from top (+CHIT), output cabling from top (+CHOT), or cabling from top (+CHCT)

**NOTE!**

The height of the standard base plinth is 100 mm, but the height of the base plinth option (+CHPH) is 200 mm.

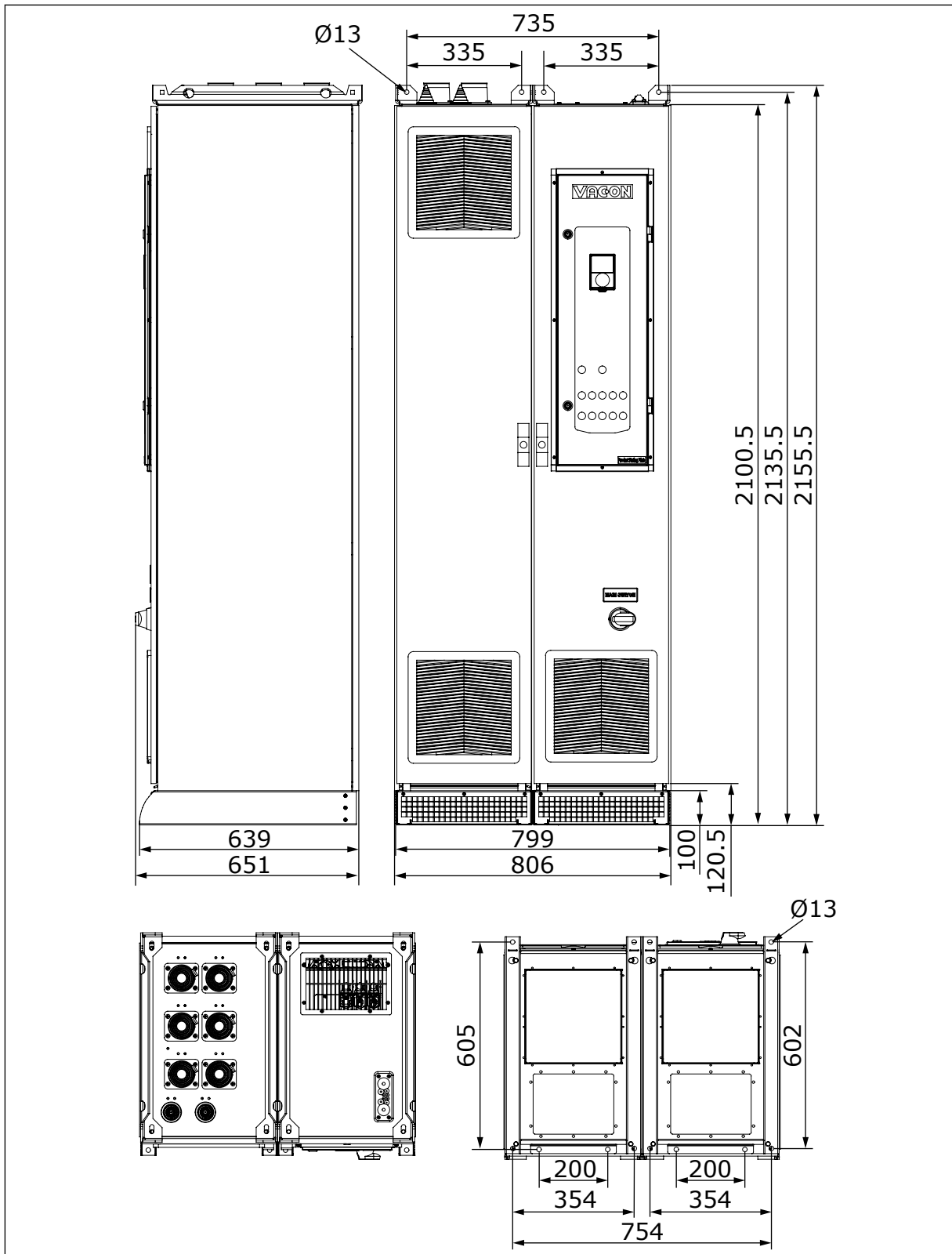

Fig. 6: The dimensions of the cabinet with the optional cabling from top, MR8, [mm], IEC

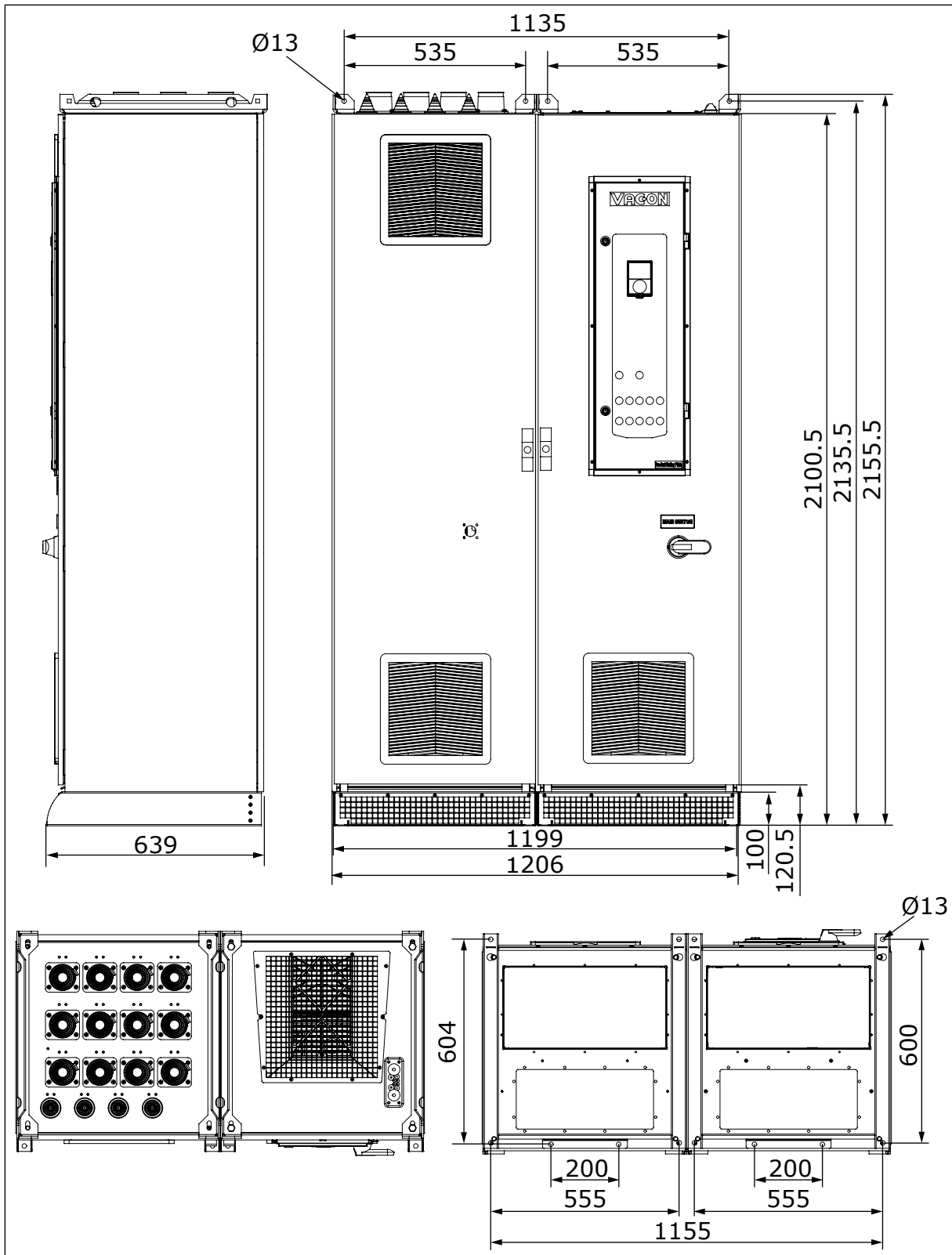

Fig. 7: The dimensions of the cabinet with the optional cabling from top and the input contactor, MR10 with min 416 A, [mm], IEC. See Table 7.

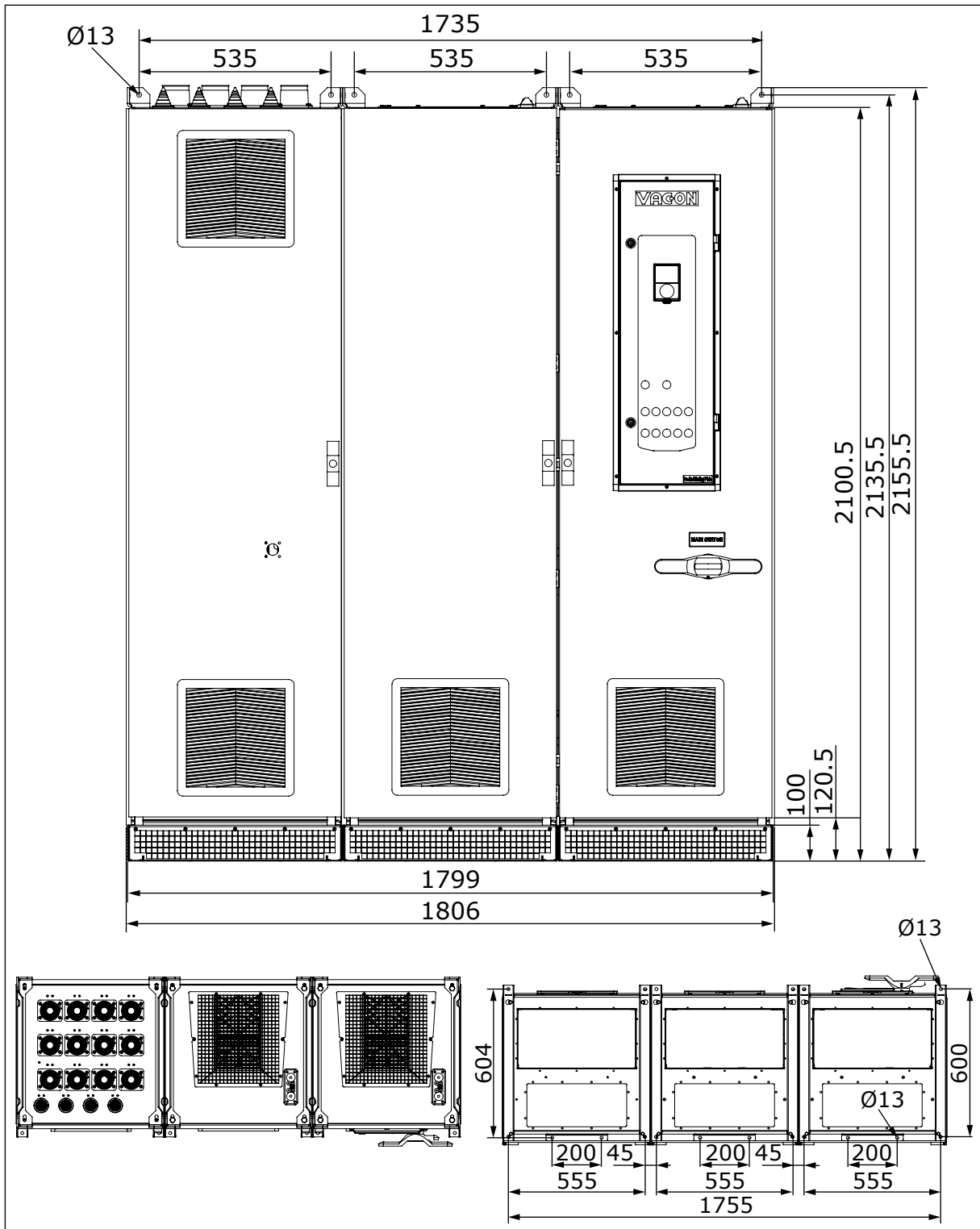

Fig. 8: The dimensions of the cabinet with the optional cabling from top and/or the input contactor, MR11 and MR12, [mm], IEC

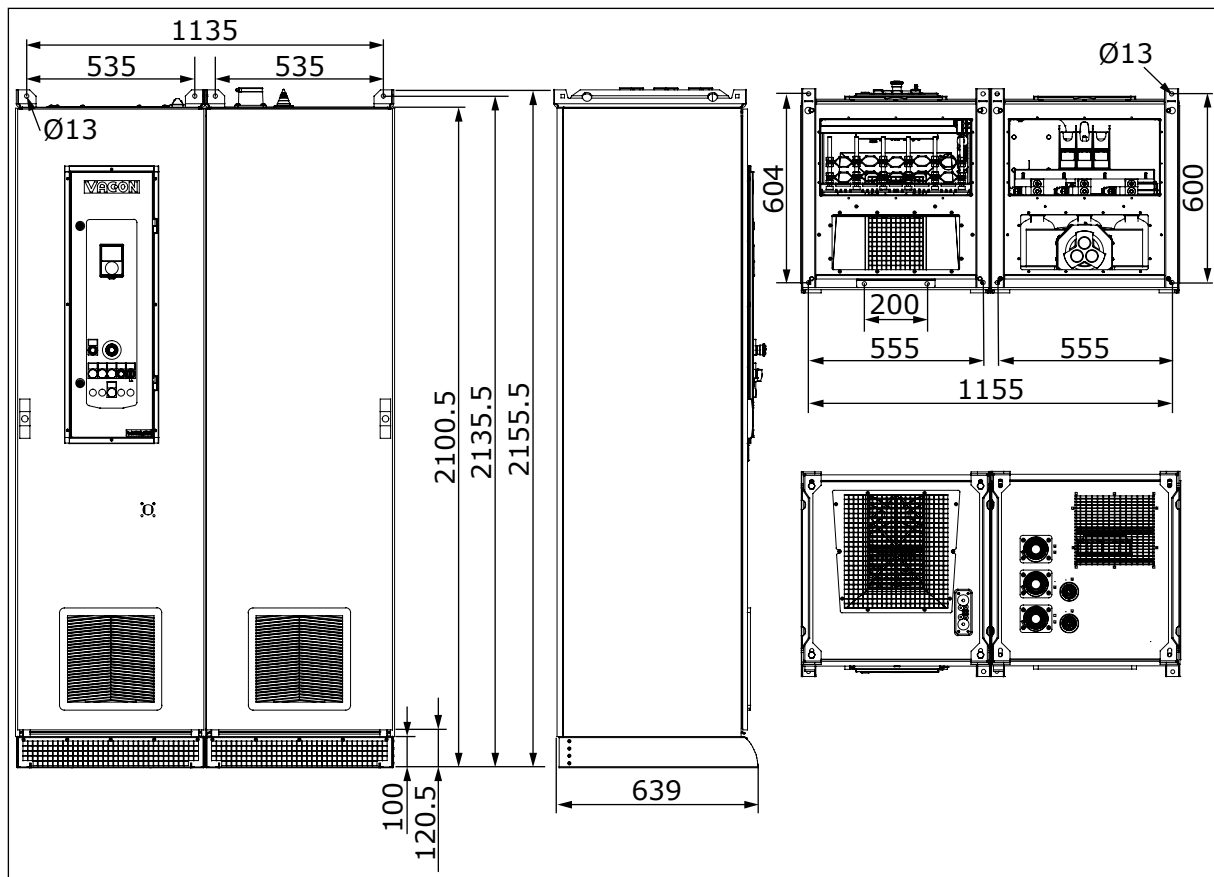

Fig. 9: The dimensions of the cabinet with the optional sine filter, MR10, [mm], IEC

4.3 DIMENSIONS OF THE CABINET, NAM

IEC = The product is qualified to the IEC criteria.

NAM = The product is qualified to the UL criteria.

The information on dimensions that you will need in cabling can be found in the order-specific documents.

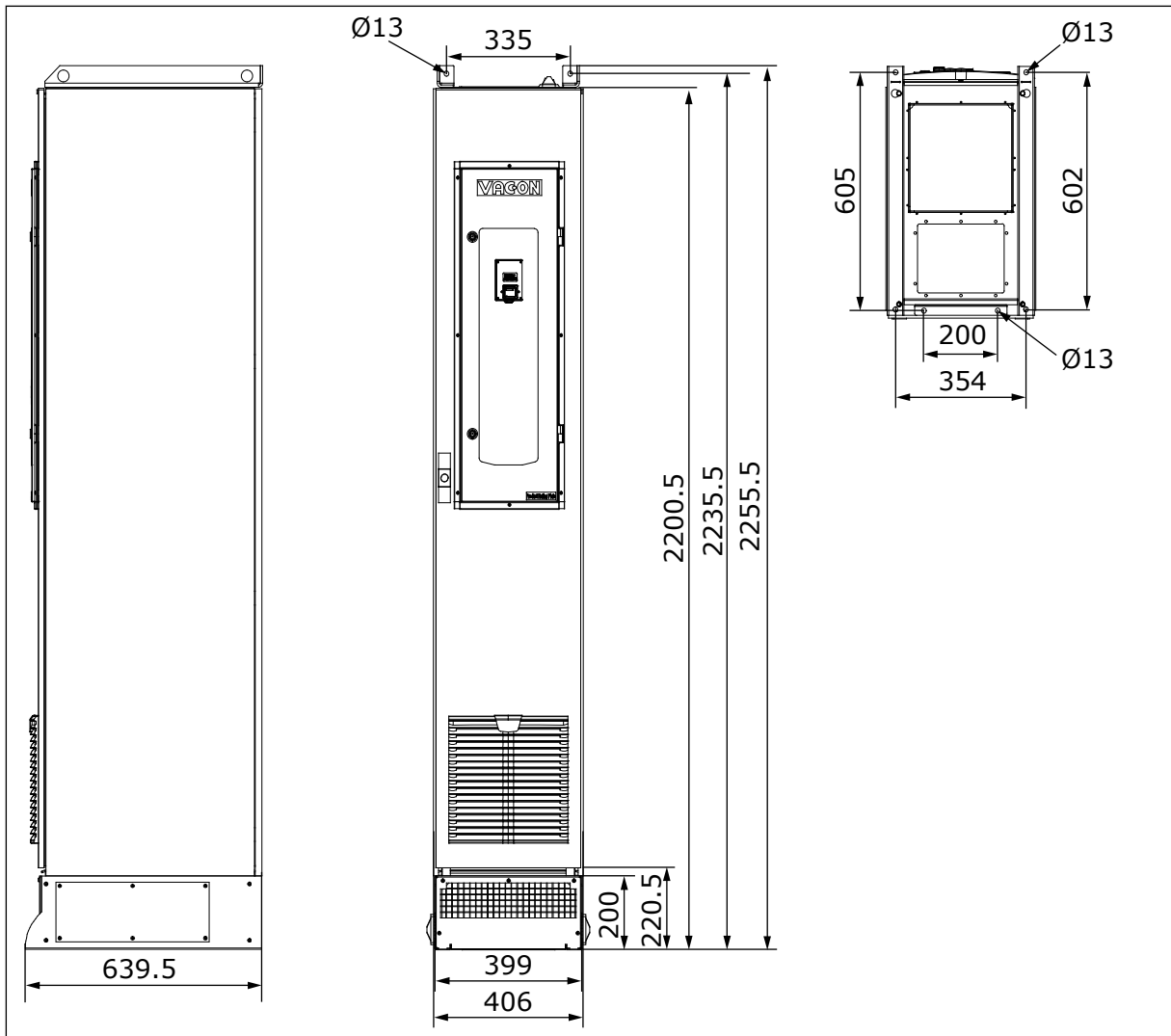

Fig. 10: The dimensions of the default cabinet, MR8, [mm], NAM

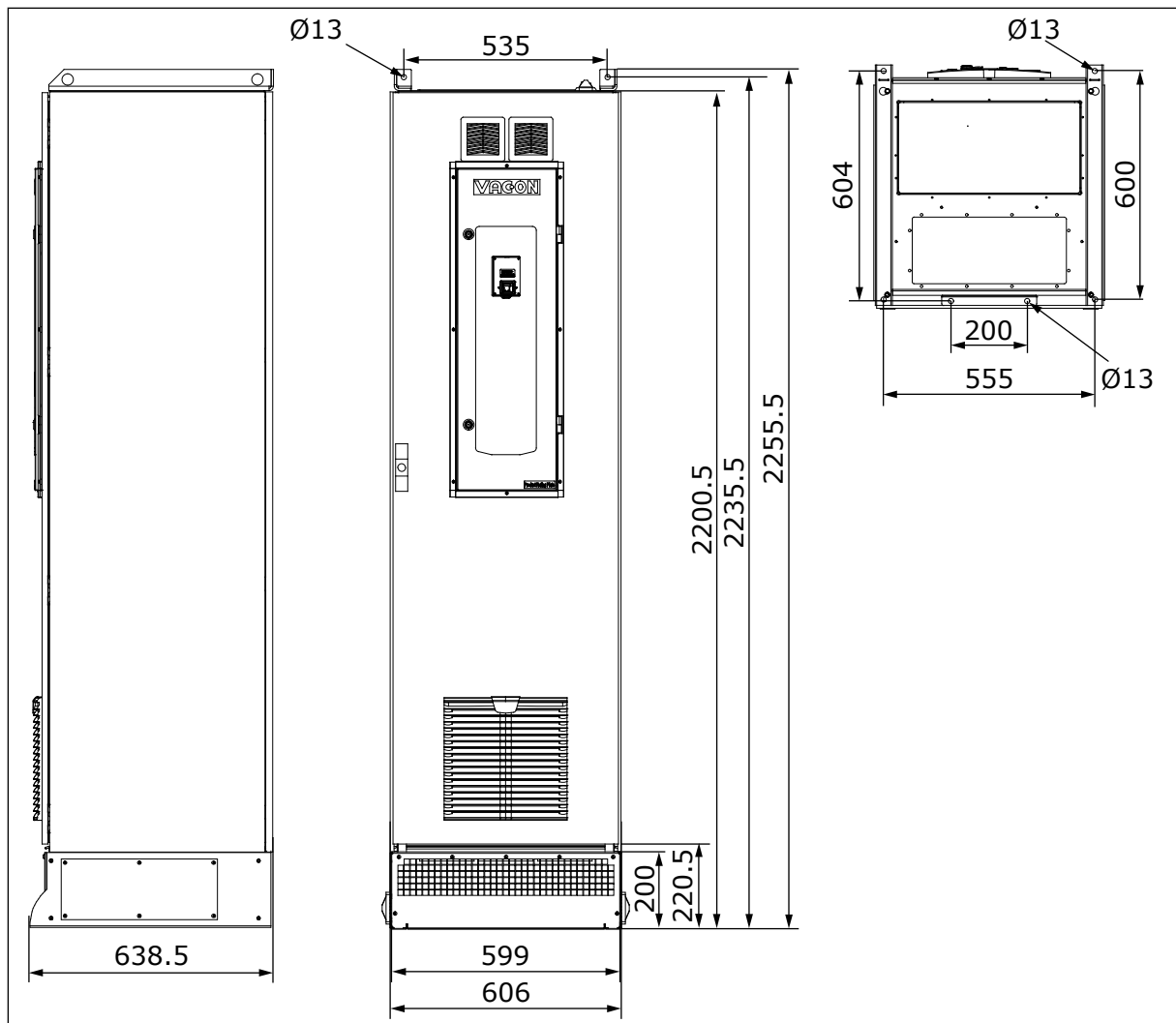

Fig. 11: The dimensions of the default cabinet, MR9 and MR10, [mm], NAM

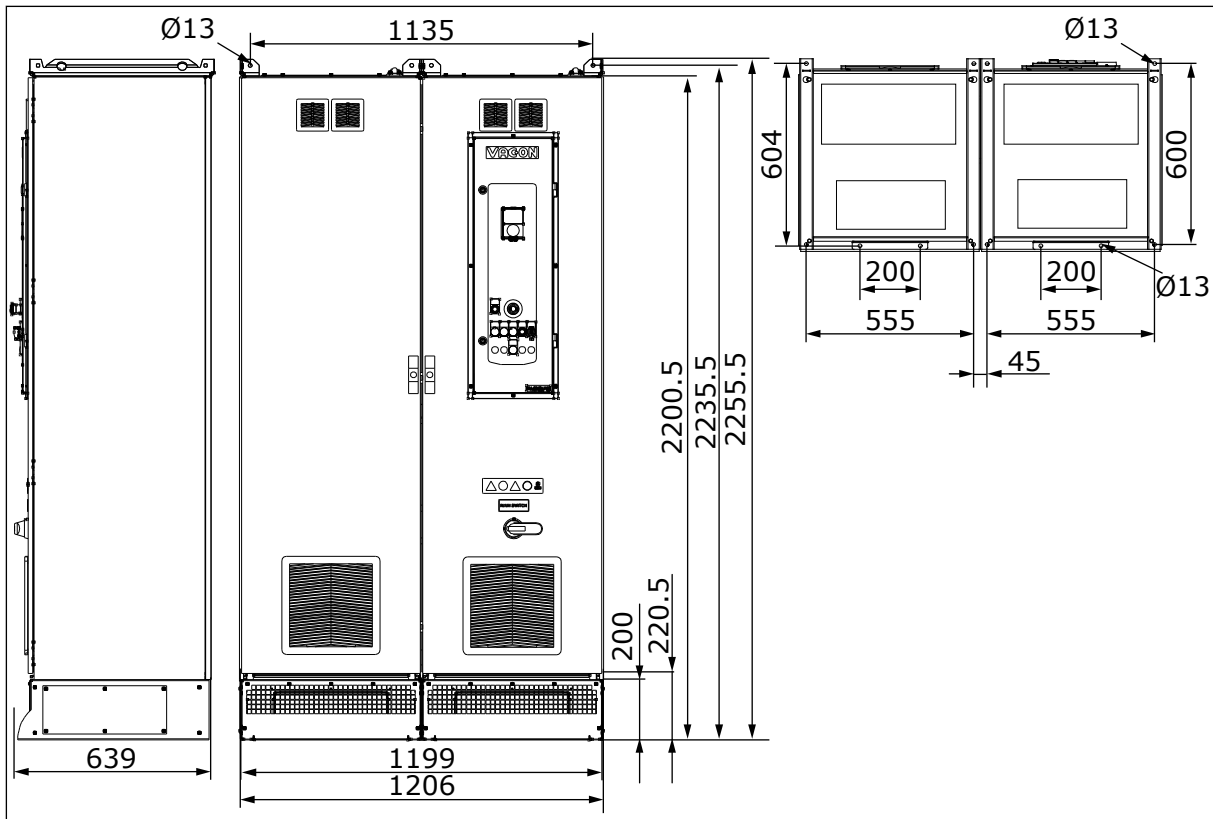

Fig. 12: The dimensions of the default cabinet, MR11, [mm], NAM

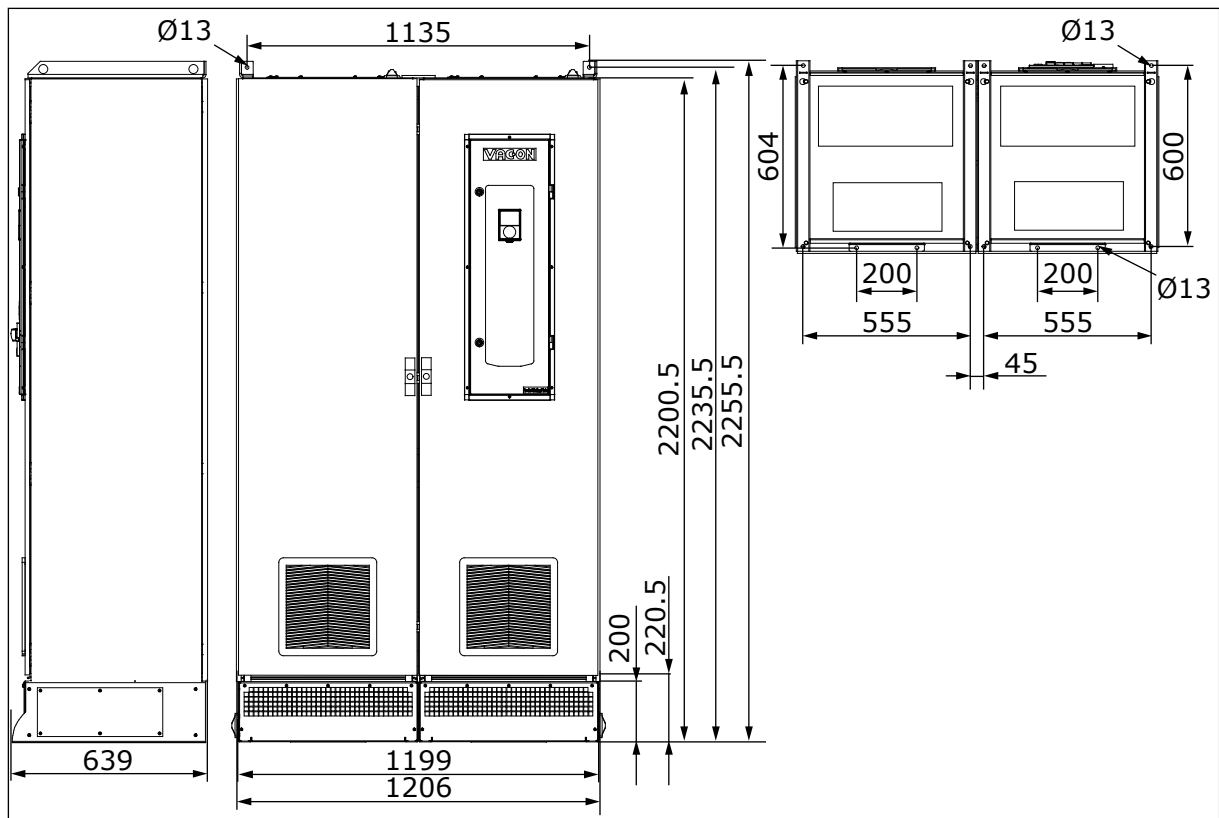

Fig. 13: The dimensions of the default cabinet, MR12, [mm], NAM

4.4 DIMENSIONS OF THE CABINET, WITH ADDITIONAL CABINET SECTIONS, NAM

IEC = The product is qualified to the IEC criteria.

NAM = The product is qualified to the UL criteria.

The information on dimensions that you will need in cabling can be found in the order-specific documents.

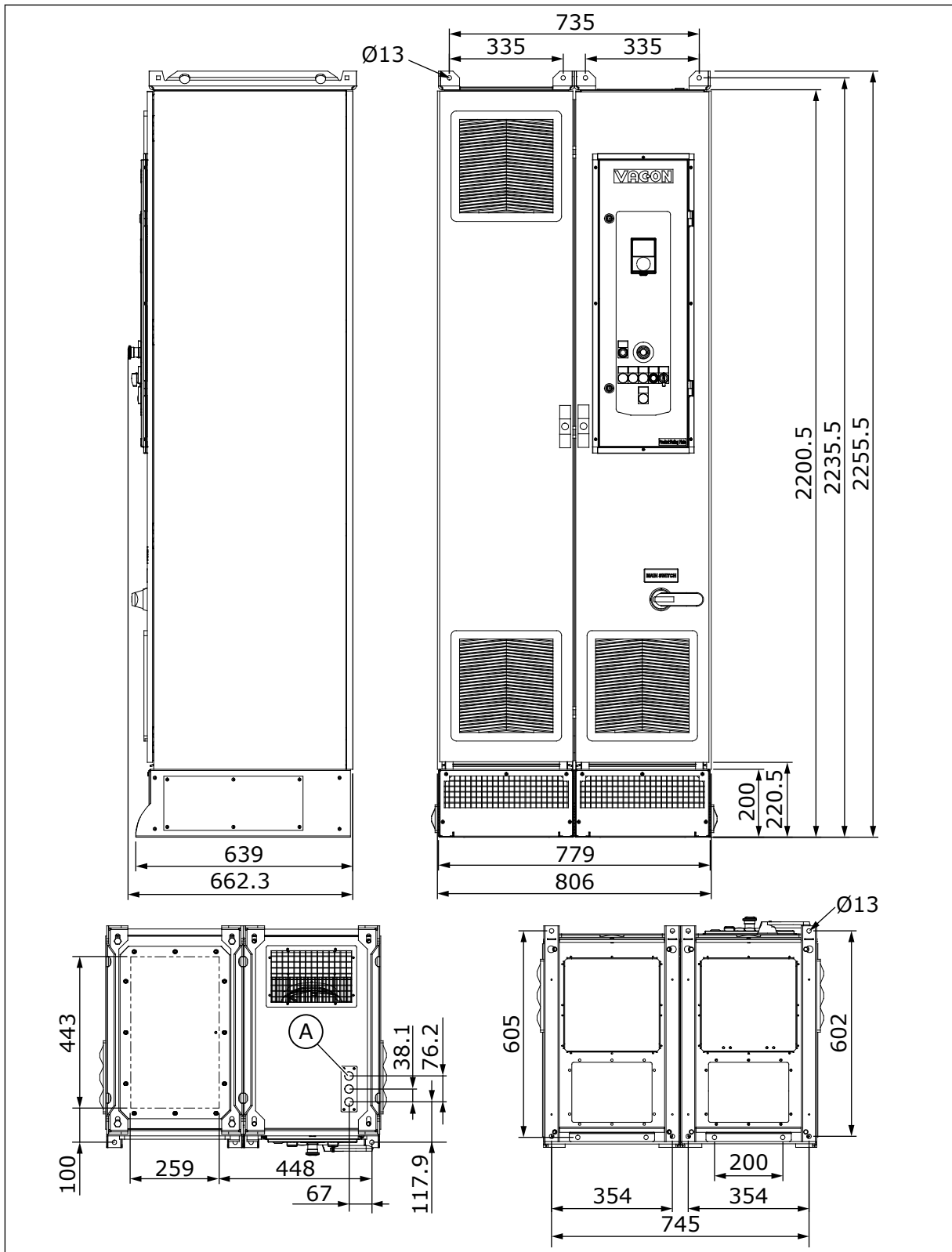

Fig. 14: The dimensions of the cabinet with the optional cabling from top, MR8, [mm], NAM

A. 3 x conduit hole Ø 22 mm

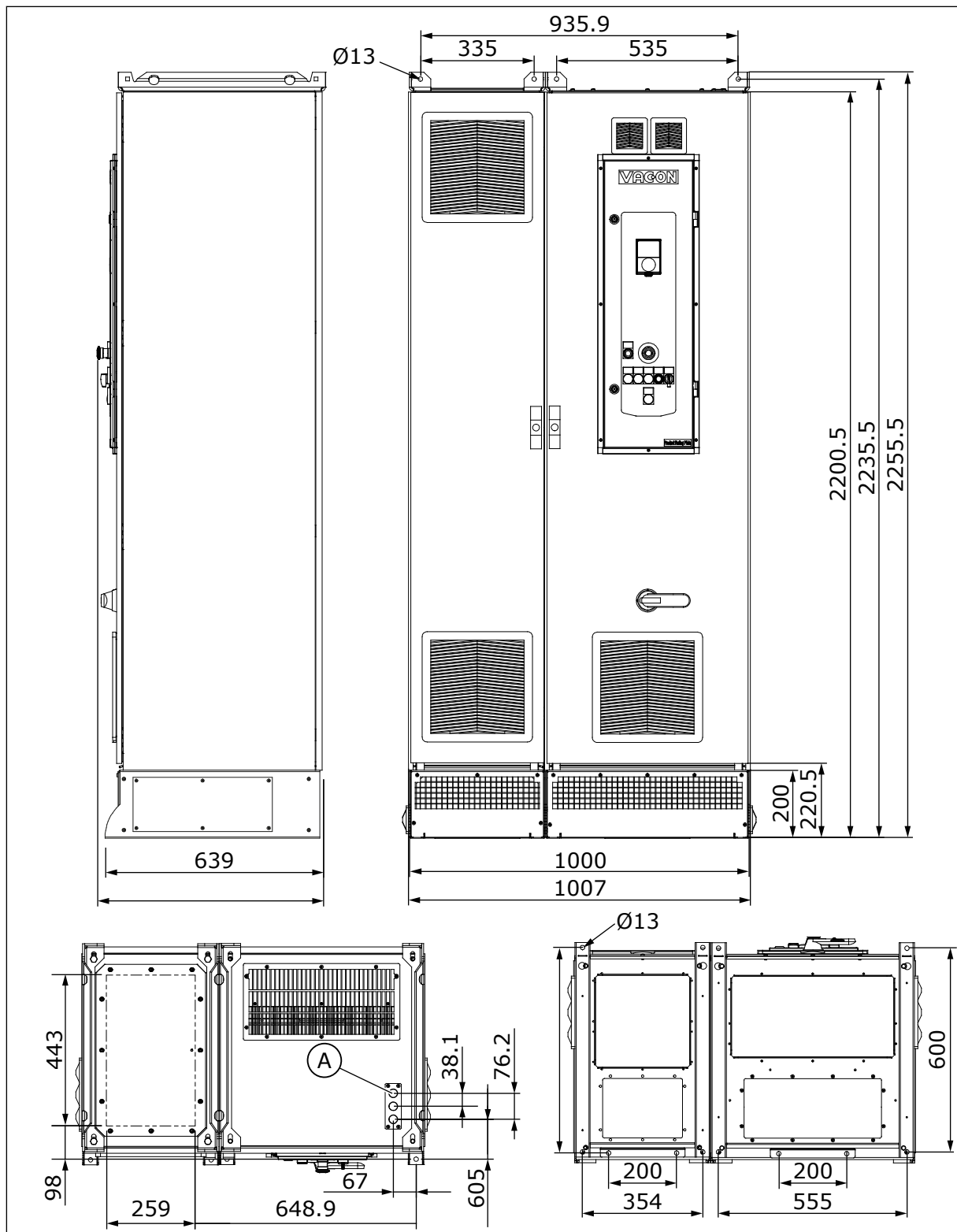

Fig. 15: The dimensions of the cabinet with the optional cabling from top, MR9, [mm], NAM

A. 3 x conduit hole Ø 22 mm

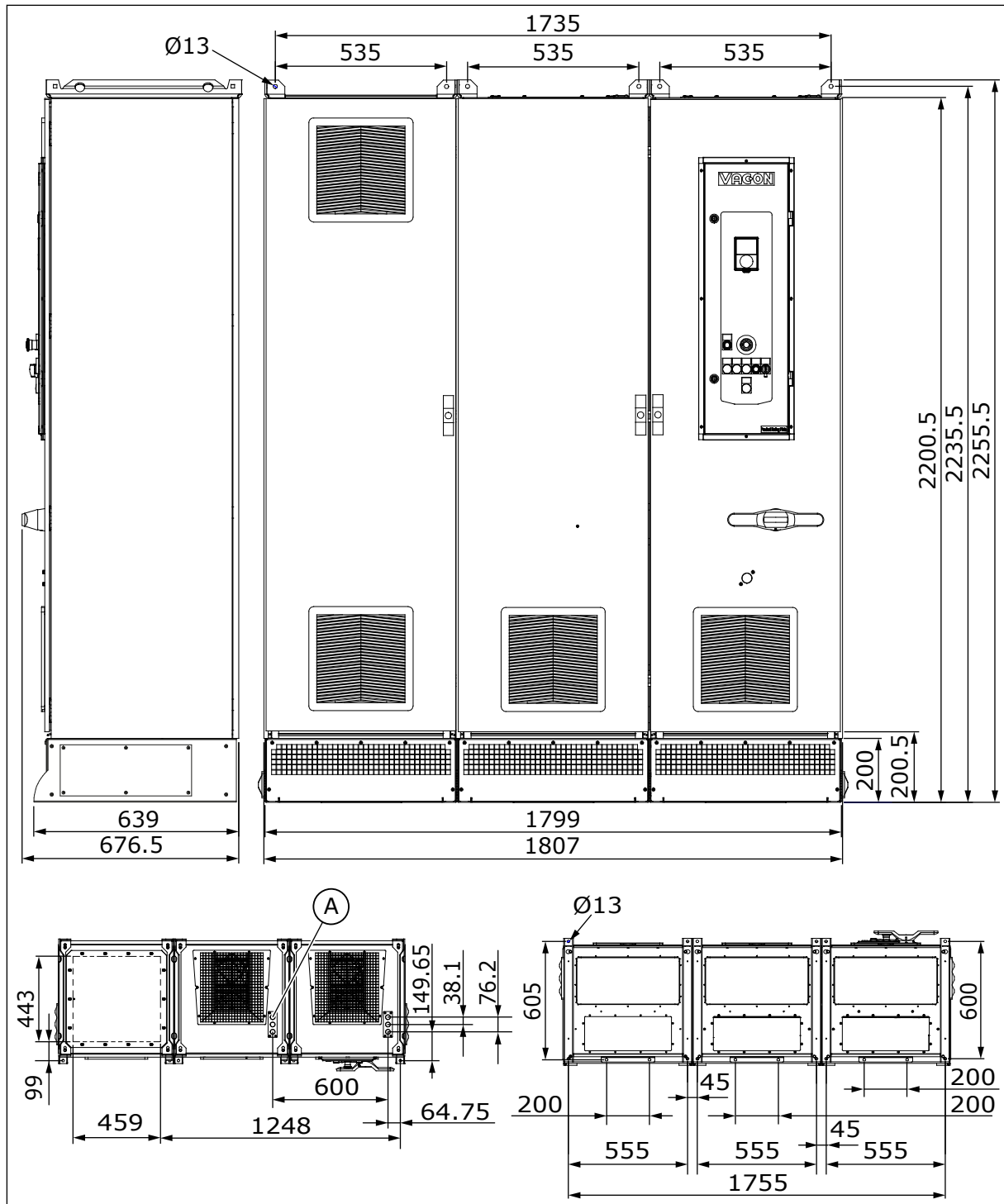

Fig. 16: The dimensions of the cabinet with the optional cabling from top and/or the input contactor, MR12, [mm], NAM. The image shows the AC drive with the optional cabling from top.

A. 6 x conduit hole Ø 22 mm

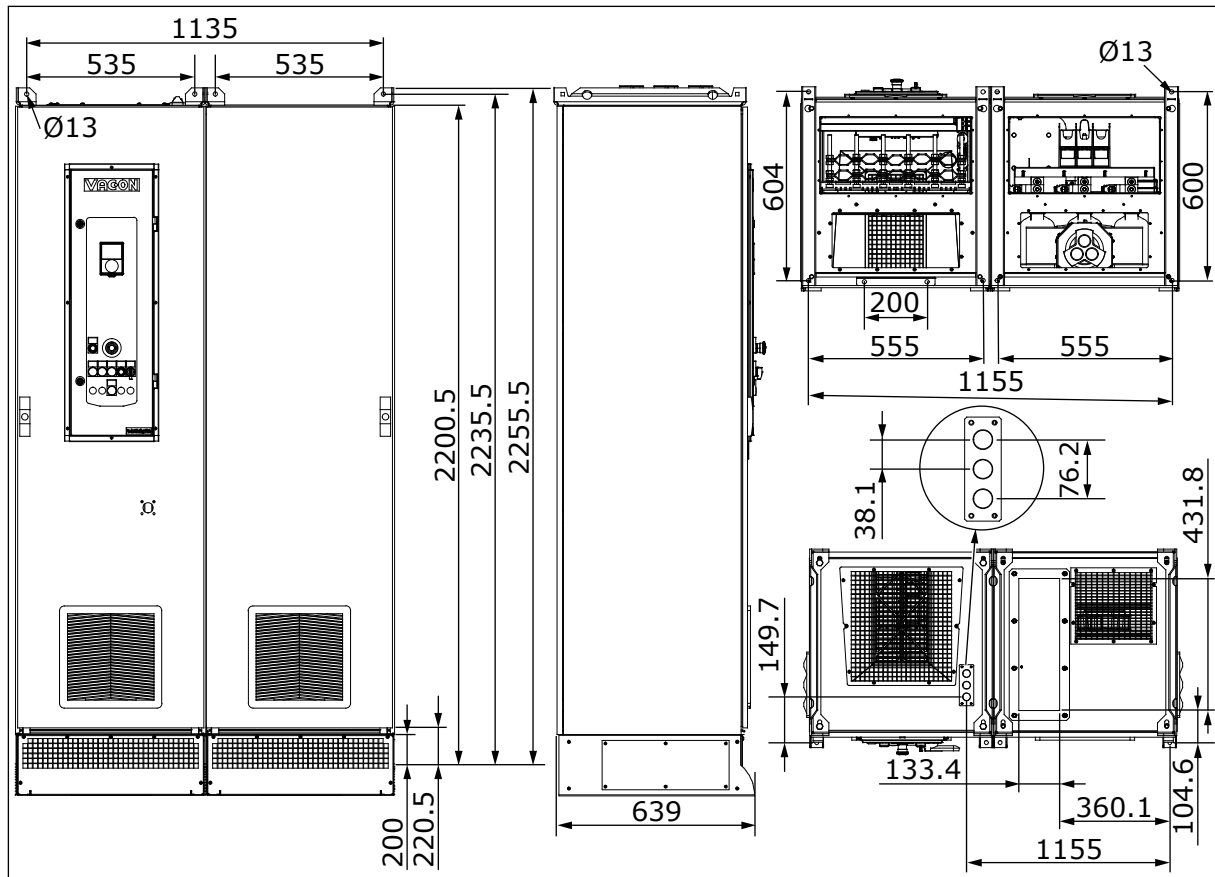

Fig. 17: The dimensions of the cabinet with the optional sine filter, MR10, [mm], NAM

4.5 THE OPTIONS

Table 8: The options and their codes

Group	Name	Code
Auxiliary equipment	Motor heater control	+CAMH
	Cabinet heater	+CACH
	Cabinet light	+CACL
Cabinet power supply for accessories	Auxiliary voltage transformer	+CAPT
	Auxiliary AC supply terminals	+CAPU
	24 VDC power supply	+CAPD
	AC customer socket	+CAPS
Door-mounted options	Signal lights and reset button	+CDLP
Control terminals	Extended I/O terminals	+CTID
Protection devices	STO with emergency stop push button on door	+CPS0
	SS1 with emergency stop push button on door	+CPS1
	Emergency switch off	+CPSB
	Insulation monitoring	+CPIF
Input devices	AC fuses and fuse switch	+CIFD
	Input contactor	+CICO *
Dynamic braking	Brake chopper	+DBIN
Output filters	Common mode filter	+POCM
	du/dt filter	+PODU
	Sine filter	+COSI
Cabling options	Input cabling from top	+CHIT
	Output cabling from top	+CHOT
	Cabling from top	+CHCT
Cabinet section options	Empty cabinet section, 400 mm, left side	+CH4L
	Empty cabinet section, 400 mm, right side	+CH4R
	Empty cabinet section, 600 mm, left side	+CH6L
	Empty cabinet section, 600 mm, right side	+CH6R

Table 8: The options and their codes

Group	Name	Code
Base plinth options	Base plinth 200 mm	+CHPH
Cooling options	Back channel cooling	+CHCB
Enclosure	IP 54	+IP54
Special construction	Marine construction	+EMAR *
Approvals	UL listed	+GAUL
	Not UL listed	+GNUL

* = These options are not available for the NAM variation.

+ CAMH: MOTOR HEATER CONTROL

With this option, you can control the supply for the motor anti-condensation heater. The external supply is connected to terminals -XD1.1 that are located in the lower part of the cabinet. When the drive is not in Run state, the control relay +QAM changes the external supply to the output terminals (-XDN). When the drive is in Run state, the control relay disconnects the external supply to the motor heater. To disable the function, open the MCB - FCN.

The control relay +QAM uses the GND (-XD2:13) and relay R01 (-XD2:21) terminals.

The requirements: +CAPU Auxiliary AC supply terminals and +CAPD 24 VDC power supply

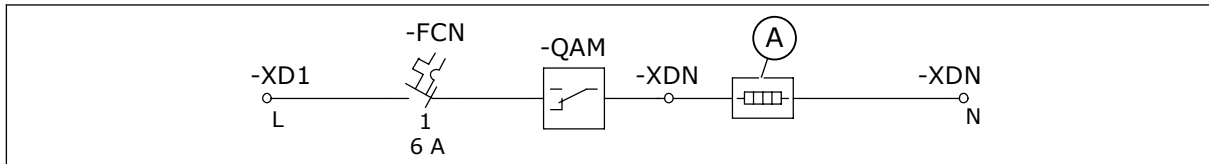

Fig. 18: The motor heater control

A. The heater element, not included in the delivery

+CACH: CABINET HEATER

This option increases the inside temperature of the cabinet above the ambient temperature, and thus prevents condensation in the cabinet. Each cabinet has 1 cabinet heater.

The external supply is connected to terminals -XD1.1. The heater element is of a selfregulating type. When the drive is not in Run state, the control relay +QAM changes the supply to the output terminals (-XD4). When the drive is in Run state, the control relay disconnects the supply to the cabinet heater. To disable the function, open the MCB -FCE.

The control relay +QAM uses the GND (-XD2:13) and relay R01 (-XD2:21) terminals.

The requirements: +CAPU Auxiliary AC supply terminals and +CAPD 24 VDC power supply.

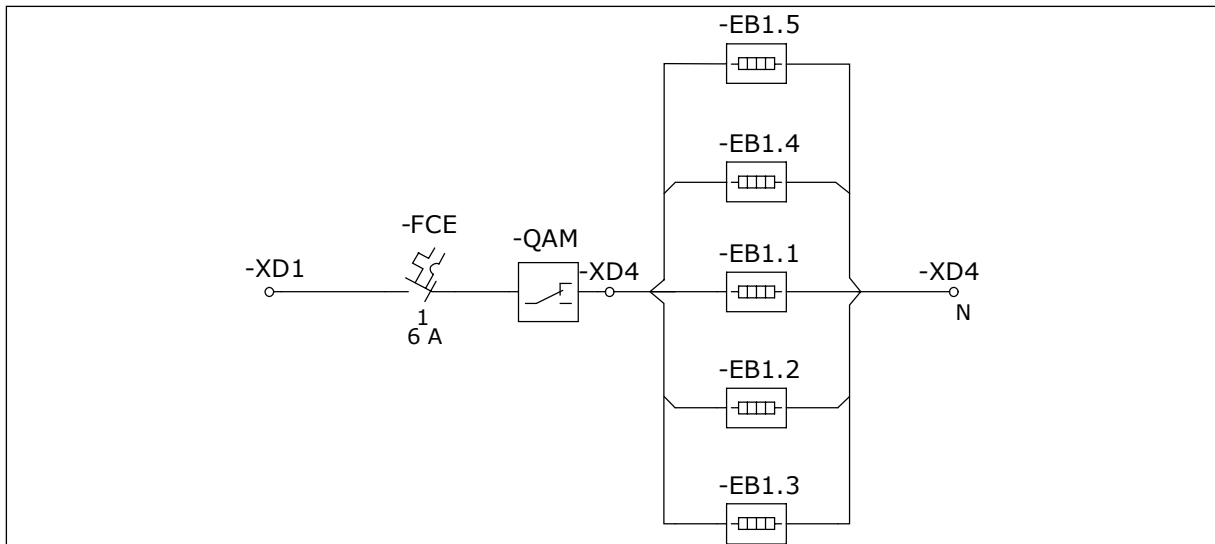

Fig. 19: The cabinet heater

+CACL: CABINET LIGHT

With this option the control compartment will have a light as default by an internal auxiliary transformer or as an option by an external auxiliary voltage supply connected to -XD1.1.

The requirements: +CAPU Auxiliary AC supply terminals or +CAPT Auxiliary voltage transformer

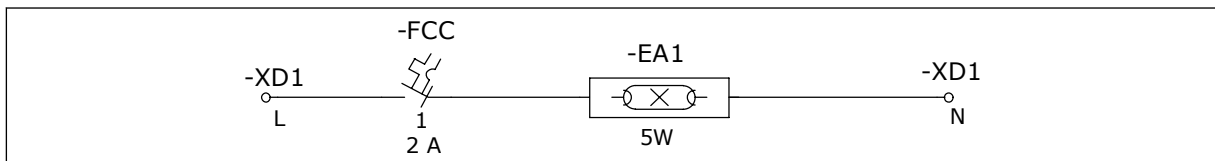

Fig. 20: The cabinet light

+CAPT: AUXILIARY VOLTAGE TRANSFORMER

This option provides the supply of auxiliary voltage for other options. The supply for the auxiliary transformer is taken from mains. If you use the option AC fuses and fuse switch (+CIFD), the supply for the auxiliary voltage transformer is taken from between the drive and the fuse switch. This means that the control voltage is disconnected with the main switch.

The requirements: Not +CAPU Auxiliary AC supply terminals

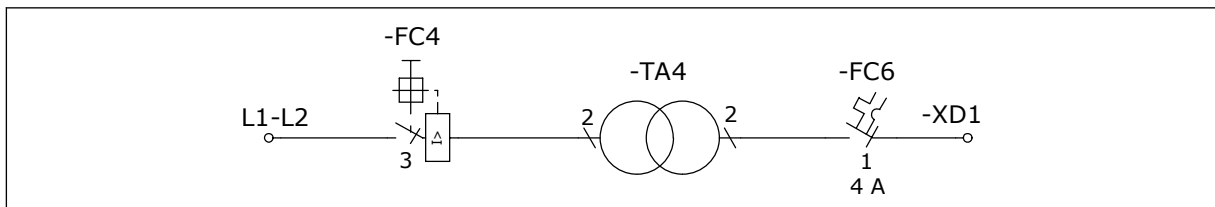

Fig. 21: The auxiliary voltage transformer

+CAPU: AUXILIARY AC SUPPLY TERMINALS

This option provides terminals –XD1.1 for an external voltage supply. The external supply must be short-circuit protected. The power of this supply depends on other selected cabinet options.

The requirements: Not +CAPT Auxiliary voltage transformer.



WARNING!

The main switch does not disconnect the external voltage supply. Before you touch the components of the control compartment, disconnect the external voltage supply. The voltage can be very dangerous.

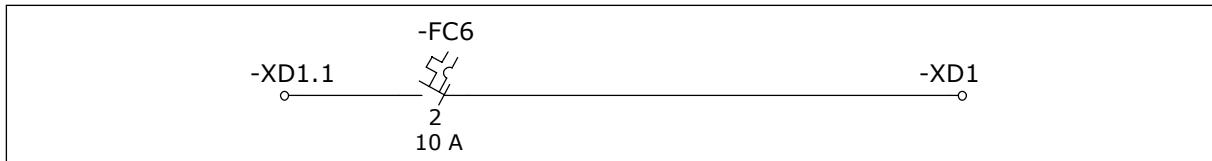

Fig. 22: The auxiliary AC supply terminals

+CAPD: 24 VDC POWER SUPPLY

This option provides a backup supply for the control unit of the drive. Use it also for other auxiliary options for which a 24 VDC supply is necessary.

The +24 VDC voltage is supplied to the GND (-XD2:20) and +24 Vin (-XD2:30) terminals.

The requirements: +CAPU Auxiliary AC supply terminals or +CAPT Auxiliary voltage transformer. The backup supply for the control unit requires +CAPU Auxiliary AC supply terminals, because for +CAPU, the power is not switched off with the main switch.

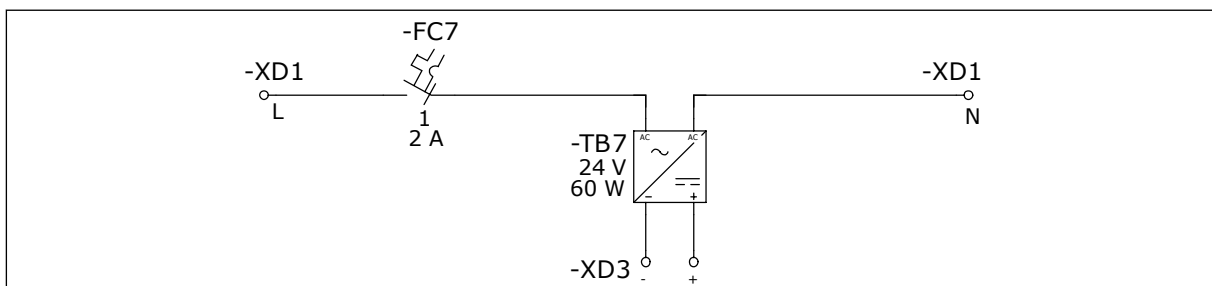

Fig. 23: The 24 VDC power supply

+CAPS: AC CUSTOMER SOCKET

The socket provides a power supply for your measurement equipment, tools or computer. The type of the socket is CEE 7/3 ("Schuko", Type F) or NEMA 5-15 grounded (Type B).

The default voltage is 230 VAC, and 115 VAC in the North American regional variant. The maximum output power with 230 VAC is 450 VA and with 115 VAC it is 230 VA when an external supply (+CAPU) is used, and 180 VA when a transformer supply (+CAPT) is used.

The requirements: +CAPU Auxiliary AC supply terminals or +CAPT Auxiliary voltage transformer

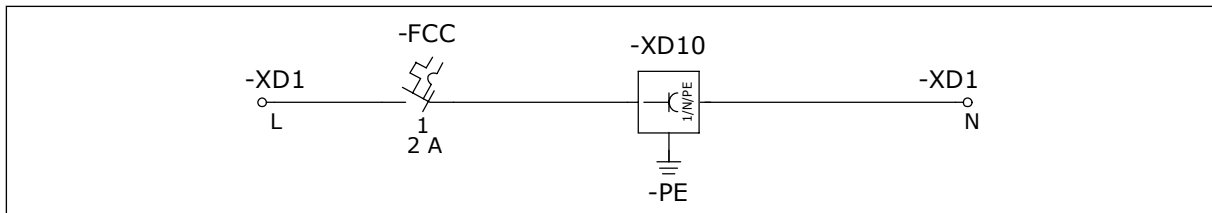

Fig. 24: The AC customer socket

+CDLP: SIGNAL LIGHTS AND RESET BUTTON

This option includes signal lights on the control compartment door for Ready, Run and Fault states of the AC drive. The door also has a button for the reset function of the AC drive. The Ready signal light is not available if you use the optional relay board OPTF4.

If you use the relay board OPTF3, this option uses the digital input 6 (-XD2:16) and the relays R01 (-XD2:23), R02 (-XD2:26) and R03 (-XD2:33).

The requirements:

- +CAPD 24 VDC power supply
- +CAPU Auxiliary AC supply terminals or +CAPT Auxiliary voltage transformer

+CTID: EXTENDED I/O TERMINALS

The option includes 20 control terminals (-XDW) in the control compartment for your own free use.

No requirements.

+CPS0: STO WITH EMERGENCY STOP PUSH BUTTON ON DOOR

This option provides the STO (Safe Torque Off) function with the OPT-BJ option board and an emergency stop push button on the door of the control compartment. The STO Channel 1 and STO Channel 2 are wired to the emergency stop push button. The STO function corresponds to an emergency stop category 0. See the user manual of the OPT-BJ option board for the regulations and the certified safety functions.

The requirements:

- The option board OPT-BJ
- +CAPD 24 VDC power supply
- +CAPU Auxiliary AC supply terminals or +CAPT Auxiliary voltage transformer

+CPS1: SS1 WITH EMERGENCY STOP PUSH BUTTON ON DOOR

This option provides the SS1 (Safe Stop 1) function with the OPTBJ option board, a safety relay and an emergency stop push button on the control compartment door. Pushing the emergency stop push button activates the motor deceleration and makes the motor stop in the set deceleration ramp time. The STO Channel 1 and STO Channel 2 are wired to the safety relay that activates the STO function after the set delay. See the user manual of the OPTBJ option board and the safety relay for the regulations and the certified safety functions.

This option uses the digital input 5 (-XD2:15).

The requirements:

- The option board OPTBJ
- +CAPD 24 VDC power supply
- +CAPU Auxiliary AC supply terminals or +CAPT Auxiliary voltage transformer



CAUTION!

The delay of the safety relay is process/machine-dependent. The designer and the user of your system are responsible for understanding and setting the delay of the safety relay. An incorrect delay can cause damage to the equipment.

+CPSB: EMERGENCY SWITCH OFF

The Emergency switch off function uses an input contactor to disconnect the drive from mains. Pushing the emergency stop push button on the control compartment door opens the control circuit of the input contactor.

The requirements:

- +CICO Input contactor and +CIFD AC fuses and fuse switch
- +CAPU Auxiliary AC supply terminals or +CAPT Auxiliary voltage transformer

+CPIF: INSULATION MONITORING

With this option it is possible to monitor the insulation level in an IT supply network with an insulation monitor in the control compartment. The insulation monitor supervises the supply and the insulation faults in the output network.

The requirements:

- +CAPD 24 VDC power supply
- +CAPU Auxiliary AC supply terminals or +CAPT Auxiliary voltage transformer

+CIFD: AC FUSES AND FUSE SWITCH

When you have this option, you can isolate the drive safely from the mains with a fuse switch that is located directly below the power unit.

With the enclosure size MR12 and the input contactor +CICO, the fuse switches are located in the additional cabinet section. The fuse switches have overtemperature protection by means of a thermostat. When the temperature limit of the thermostat is reached, a safety circuit opens and an external fault occurs. The function uses the terminals +24 Vout (-XD2:12) and digital input 4 (-XD2:14).

The wiring of the option can be seen in chapter *5.1.1 Main circuit diagrams of the cabinet*.

+CICO: INPUT CONTACTOR

This option makes it possible for you to connect or disconnect the drive from mains. To do it, use a control switch on the control compartment door, or connect an external switch to terminals –XD0. To connect the external switch, refer to the electrical drawings.

The option includes the fuse switch (+CIFD) for safety reasons.

When your product is MR10 with minimum 416 A or MR12 with minimum 820 A, the option includes additional cabinet sections.

The wiring of the option can be seen in chapter *5.1.1 Main circuit diagrams of the cabinet*.

The requirements: +CAPU Auxiliary AC supply terminals or +CAPT Auxiliary voltage transformer

+DBIN: BRAKE CHOPPER

The power unit has a dynamic brake chopper. The external brake resistor is connected directly to the brake resistor terminals of the power unit, see chapter *5.4.1 Installing the cables*. The brake resistor is not included in the option.

+POCM: COMMON MODE FILTER

The option includes an output filter that decreases the common mode voltage. The filter is connected between the motor cable terminals of the power unit and the motor cable terminals of the drive. The filter does not have an effect on the connection of the external motor cables.

The wiring of the option can be seen in chapter *5.1.1 Main circuit diagrams of the cabinet*.

+PODU: DU/DT FILTER

The option includes an output filter that increases the rise time of the voltage pulse, and thus decreases the voltage stress on the motor winding insulation.

The filter is connected between the motor cable terminals of the power unit and the motor cable terminals of the drive. The filter does not have an effect on the connection of the external motor cables. With this option, the maximum length of motor cables is 150 m. If the cables are longer than 150 m, use a sine filter option.

The wiring of the option can be seen in chapter *5.1.1 Main circuit diagrams of the cabinet*.

The requirements: Not +COSI Sine filter.

+COSI: SINE FILTER

The option includes an output filter that removes the switching frequency. The output filter leaves only the output frequency and thus eliminates all voltage stress on the motor. The filter is connected after the motor cable terminals of the AC drive. The filter is located in an additional cabinet section. The option is necessary if the motor requires filtering, and if longer than 150 meter cables are used. The option can also be used with shorter cables if necessary. If you use long cables, we recommend you to use the common mode filter option (+POCM) also.

The wiring of the option can be seen in chapter 5.1.1 *Main circuit diagrams of the cabinet*.

When you use the sine filter option, make sure that the parameter Sine Filter is in use. The sine filter option is designed for a minimum of 2 kHz switching frequency. Parameter Sine Filter disables switching frequencies below 2 kHz when automatic derating becomes active.

This option has an overtemperature protection function. The coils of the sine filter have thermal relays that are connected to the control terminals of the AC drive. The function uses the terminals +24 Vout (-XD2:12) and digital input 4 (-XD2:14). When the overtemperature limit is reached, a safety circuit opens and an external fault appears. Find the cause of the fault. The cause of the fault can be, for example, a fan failure, a clogged air channel, or high ambient temperature. You can reset the fault after the sine filter has cooled down.

The requirements: Not +PODU du/dt filter.

The option includes an additional cabinet section(s).

+CHIT: INPUT CABLING FROM TOP

With this option you can make the input cables, that is, the mains cables enter the cabinet from the top.

The option includes an additional cabinet section.

+CHCT: CABLING FROM TOP

With this option you can make the cables enter the cabinet from the top.

The option includes an additional cabinet section.

+CHOT: OUTPUT CABLING FROM TOP

With this option you can make the output cables, that is, the motor cables enter the cabinet from the top.

The option includes an additional cabinet section.

Table 9: The input/output terminals in the additional cabinet section

Enclosure size	With +CHIT, +CHOT or +CHCT	With +CICO, +CHIT, +CHOT or +CHCT
MR8	-	-
MR9	-	-
MR10, max. 385 A	-	-
MR10, min. 416 A	x	x*
MR11	x	x
MR12, max. 750 A	x	x
MR12, min. 820 A	x	x*

* Input terminals at fuse switch (IEC only).

+CH4L: EMPTY CABINET SECTION, 400 MM, LEFT SIDE

The option includes an additional cabinet section (400 mm) on the left side of the main cabinet.

+CH4R: EMPTY CABINET SECTION, 400 MM, RIGHT SIDE

The option includes an additional cabinet section (400 mm) on the right side of the main cabinet.

+CH6L: EMPTY CABINET SECTION, 600 MM, LEFT SIDE

The option includes an additional cabinet section (600 mm) on the left side of the main cabinet.

+CH6R: EMPTY CABINET SECTION, 600 MM, RIGHT SIDE

The option includes an additional cabinet section (600 mm) on the right side of the main cabinet.

+CHPH: BASE PLINTH 200 MM

This option includes a 200 mm base plinth that you can use instead of the standard 100 mm base plinth.

+CHCB: BACK CHANNEL COOLING

See more in chapter 4.8 *The optional back channel cooling*.

The requirements:

- +CACH Cabinet heater
- +CAPU Auxiliary AC supply terminals
- +IP54 IP54

+IP54: IP54

This option provides the enclosure class IP54 for your product.

+EMAR: MARINE CONSTRUCTION

See more information in the Marine Installation Guide.

The requirements:

- +IP54 IP54
- +CACH Cabinet heater
- Not +CHCB Back channel cooling

+GAUL: UL LISTED

The product is qualified to the UL criteria.

+GNUL: NOT UL LISTED

The product is not qualified to the UL criteria.

4.6 INSTALLATION OF THE CABINET

Install the AC drive in a vertical position on level ground. Attach the drive with screws to the wall and/or the floor.

To attach the cabinet to the floor, there are 3 alternatives.

- Use the 4 fixing points at the bottom of the cabinet.
- Use the 2 fixing points at the front bottom and the 2 fixing points at the rear top of the cabinet.
- Use the 2 fixing points in the fixing bracket and the 2 fixing points at the front bottom of the cabinet. To use the fixing bracket, first attach it to the floor. Slide the edge of the cabinet plinth under the fixing bracket. Then attach the 2 fixing points at the front bottom.

**NOTE!**

If you have multiple additional cabinet sections (for example with MR12 or the optional cabling from top), these steps must be done for each section.

**NOTE!**

The enclosure size MR12 (>730 A) with +CICO option additional cabinet section has door fan to cool down components. The fan is supplied with 230 VAC from control compartment when the drive is powered up. Fan supervision is provided by thermostat installed in the additional cabinet section. If temperature of the additional cabinet section rises above preset limit, external fault is activated. If the external fault occurs, check the additional cabinet section fan and ambient temperature. The fault can be reset after the additional cabinet section air temperature cools down.

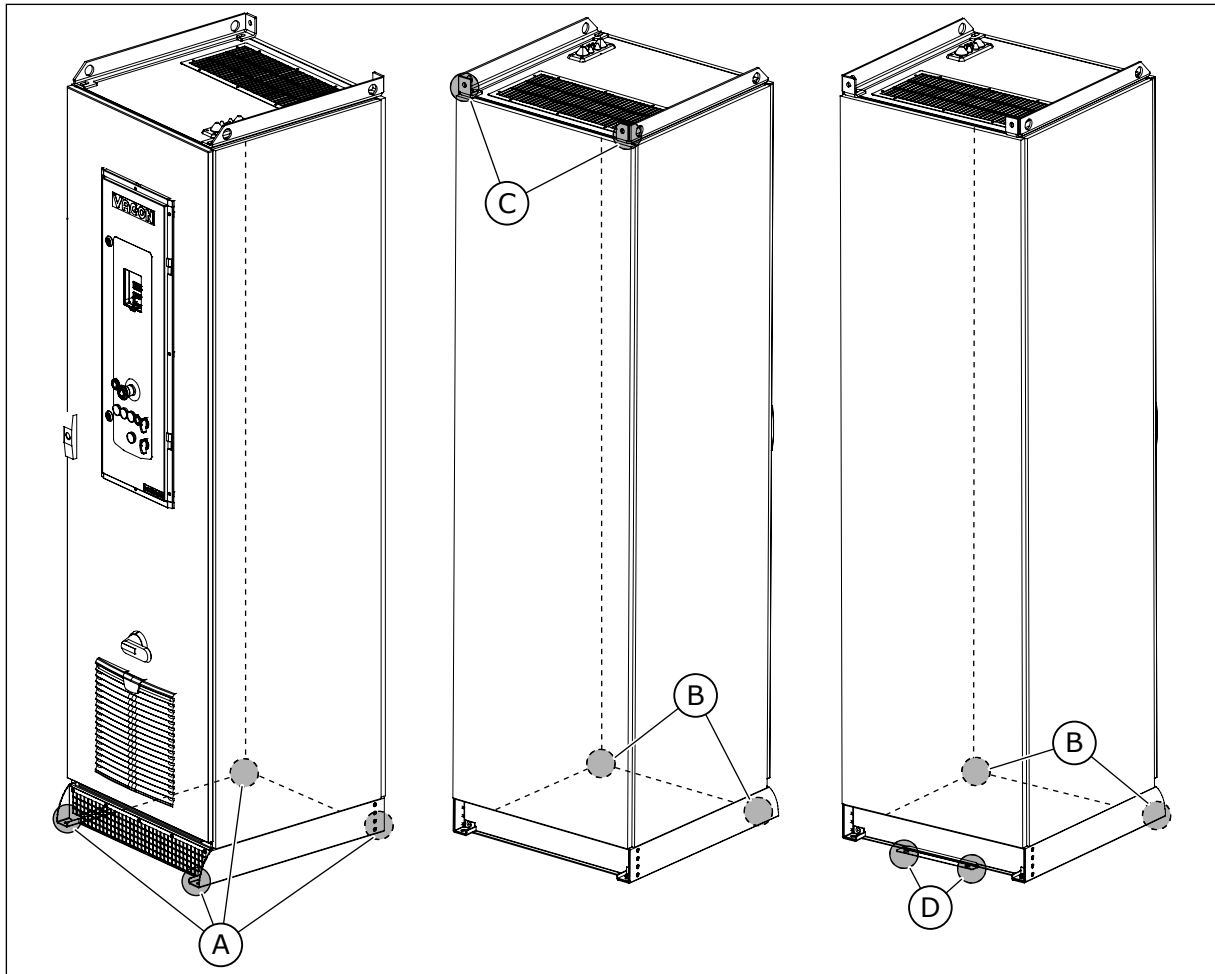

Fig. 25: The fixing points of the cabinet

- A. The 4 fixing points at the bottom
- B. The 2 fixing points at the front bottom
- C. The 2 fixing points at the rear top
- D. The 2 fixing points in the fixing bracket

4.7 COOLING AND FREE SPACE AROUND THE AC DRIVE

The cabinet fan is controlled by control unit relay R01. When the AC drive is not running, the fan is stopped. When the AC drive runs, the fan rotates. The internal temperature of the cabinet is monitored by thermostat. If the internal temperature of the cabinet exceeds the limit, the safety circuit opens and an external fault appears. This can be caused by, for example, a failed fan, a clogged air filter or high ambient temperature. Overheat reduces the lifetime of the AC drive components and may cause damages.

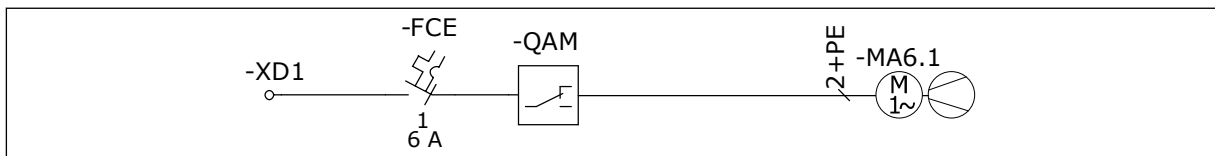

Fig. 26: The cabinet fan in MR9B

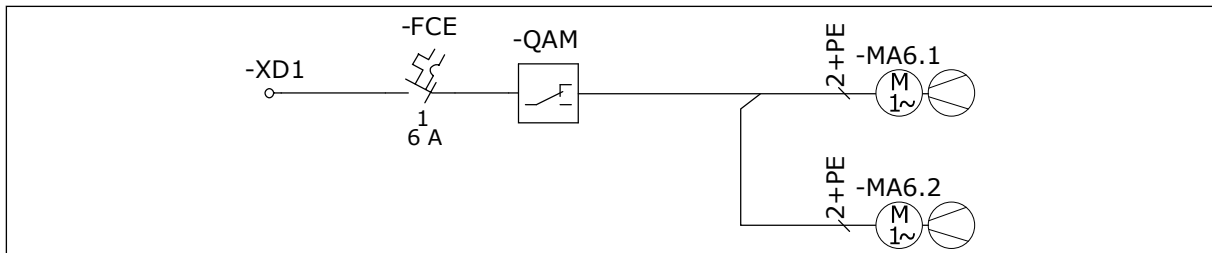

Fig. 27: The cabinet fan in MR11

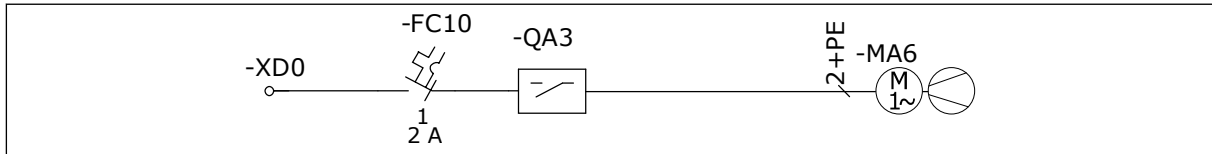

Fig. 28: The cabinet fan in MR12

The AC drive produces heat in operation. The fan circulates air and decreases the temperature of the drive. Make sure that there is sufficiently free space around the drive.

Some free space in front of the drive is also necessary for maintenance. You must also have 80 cm of free space in front of the cabinet to be able to open the cabinet door. When you have 2 or more drives, you can install them side by side.

Make sure that the temperature of the cooling air does not become higher than the maximum ambient operating temperature or lower than the minimum ambient operating temperature of the drive.

The air must move freely and efficiently through the cabinet and the drive. There must be a minimum of 30 cm of space above the cabinet without obstacles that can stop the airflow. Make sure that the hot air goes out of the cabinet and does not come back into the cabinet.

The power loss of the AC drive can change significantly, when the load, the output frequency or the switching frequency changes. It is useful to know the power loss, when you plan the cooling equipment in an electrical room. Use this formula to calculate the approximate power loss of the drive in nominal conditions.

$$P_{\text{loss}} [\text{kW}] = P_{\text{mot}} [\text{kW}] \times 0.025$$

It is possible that there will be an increase of 0-0.5% in the power loss when you have options in the cabinet. Some options, for example output filters and input devices, cause more power losses.

To calculate the power loss, use the ecoSmart tool. See www.danfoss.com.

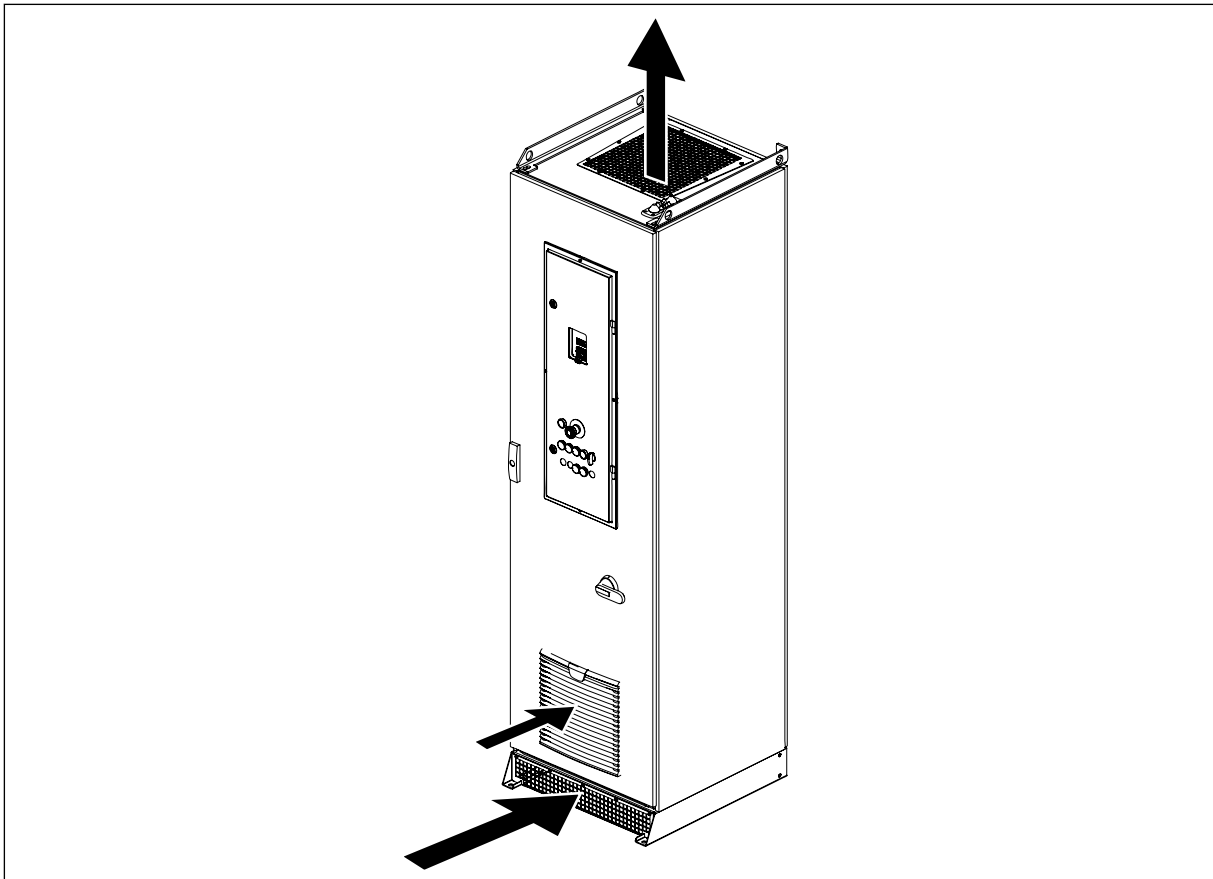

Fig. 29: The circulation of cooling air

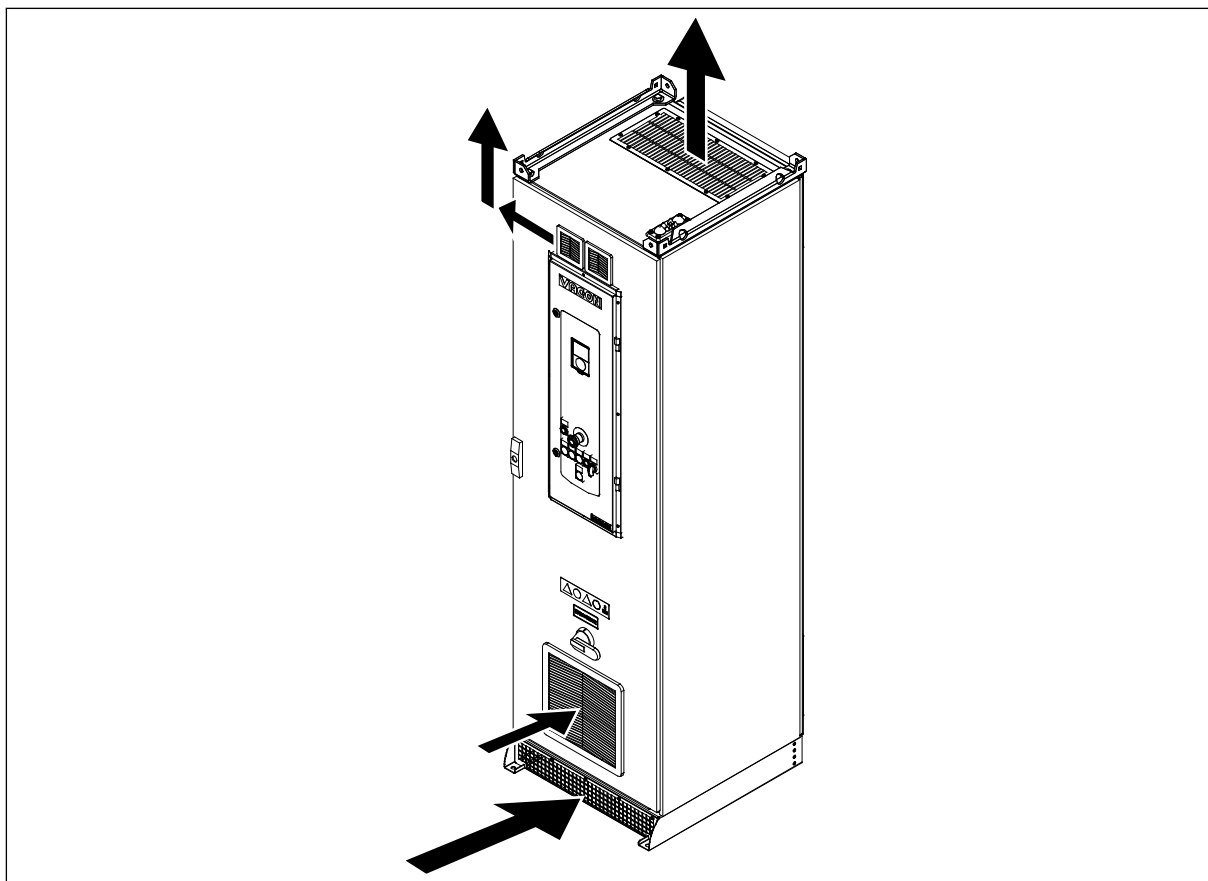

Fig. 30: The circulation of cooling air in MR9B and MR11

Table 10: The necessary quantity of cooling air

Enclosure size	The quantity of cooling air [m ³ /h]
MR8	330
MR9	620
MR10	1400
MR11	2 x 620
MR12	2 x 1400

4.8 THE OPTIONAL BACK CHANNEL COOLING

You can also use the back channel cooling option (+CHCB) for the cooling of the AC drive. With this option, the intake air to the main cooling channel of the AC drive can be taken from

and exhausted to the outside of the electrical room. Because the heat losses of the drive are directed outside, the cooling load of the electrical room is reduced.

USING THE BACK CHANNEL FOR COOLING

- 1 Make an opening in the wall behind the cabinet.
- 2 To prevent condensation in the cabinet, connect the supply cable of the cabinet heater (+CACH, delivered as default with this option) to the correct terminals in the control compartment.
- 3 Attach the duct adapter flanges to the cabinet with screws.
- 4 Do not install the cabinet in an airtight space. Approximately 5-10% of the intake air must come from the front.

- The estimated amount of intake air is for MR8: 0 m³, MR9: 10m³, for MR10: 20m³, for MR11: 20m³, for MR12: 40m³.



NOTE!

MR8 does not take in air from the front.

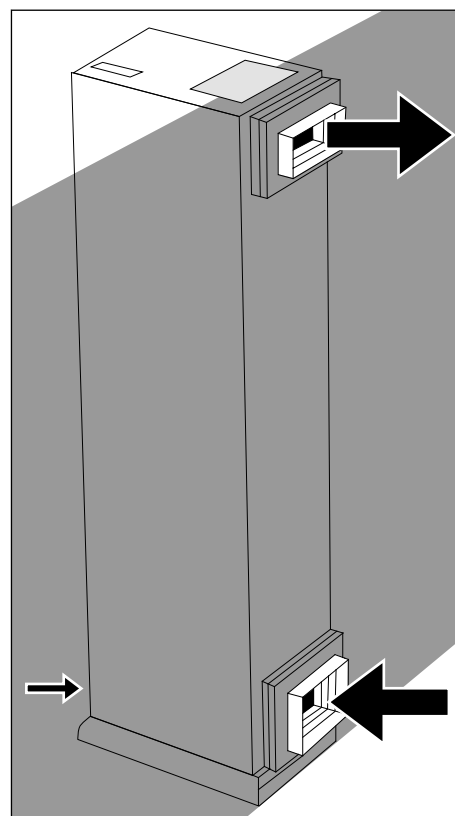

- 5 Make sure that there are no particles in the air that can block the heat sink.
- 6 Move the cabinet adjacent to the wall, or attach the duct adapter flanges to the air duct.
 - Do not make attachments to other parts of the drive except the white flange that you can see in the picture.
- 7 Make sure that you seal the openings correctly.

**CAUTION!**

If you use long air ducts in addition to the duct adapter flanges, use a duct fan or equivalent to prevent back pressure. Back pressure must be prevented because it decreases the performance of the drive.

**NOTE!**

The height of the standard base plinth is 100 mm, but the height of the base plinth option (+CHPH) is 200 mm.

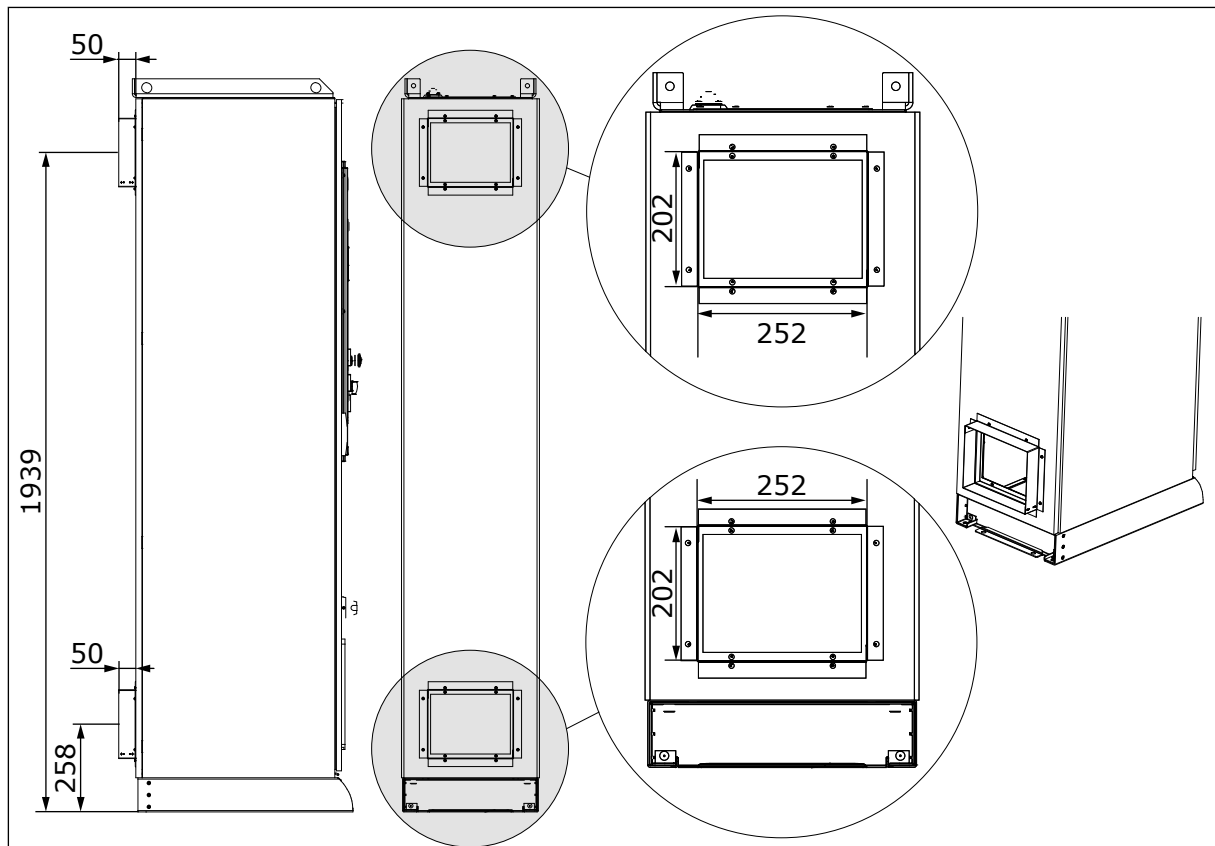

Fig. 31: Dimensions for the back channel cooling, MR8

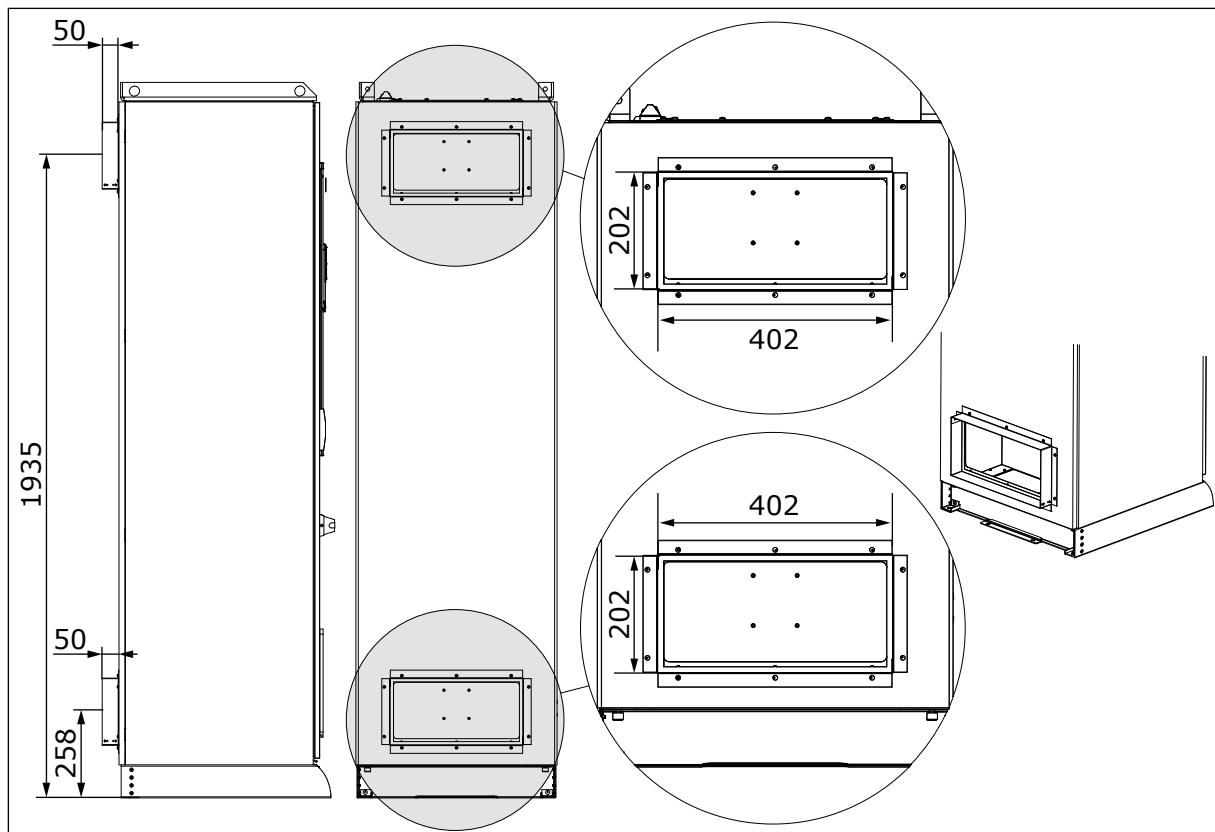

Fig. 32: Dimensions for the back channel cooling, MR9 and MR10

The additional cabinet sections do not need back channels. The exception is the additional cabinet section of the sine filter option, which has back channel cooling.

In MR11 and MR12, there are two back channels.

5 POWER CABLING

5.1 CABLE DIMENSIONING AND SELECTION

5.1.1 MAIN CIRCUIT DIAGRAMS OF THE CABINET

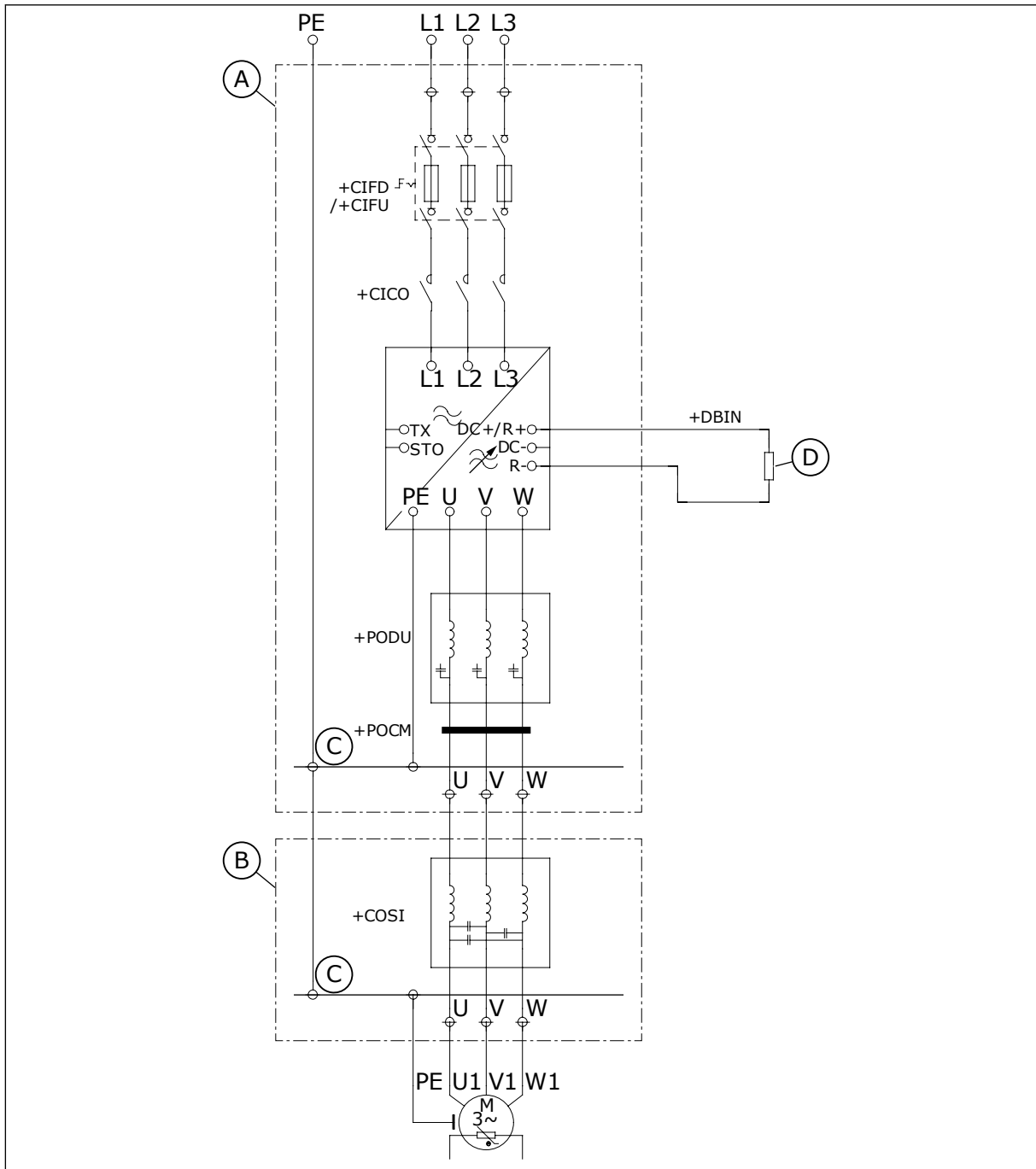

Fig. 33: Main circuit diagram of the cabinet, MR8-MR10

A. Main cabinet

B. Sine filter cabinet

C. PE bus

D. Brake resistor (not included in delivery)

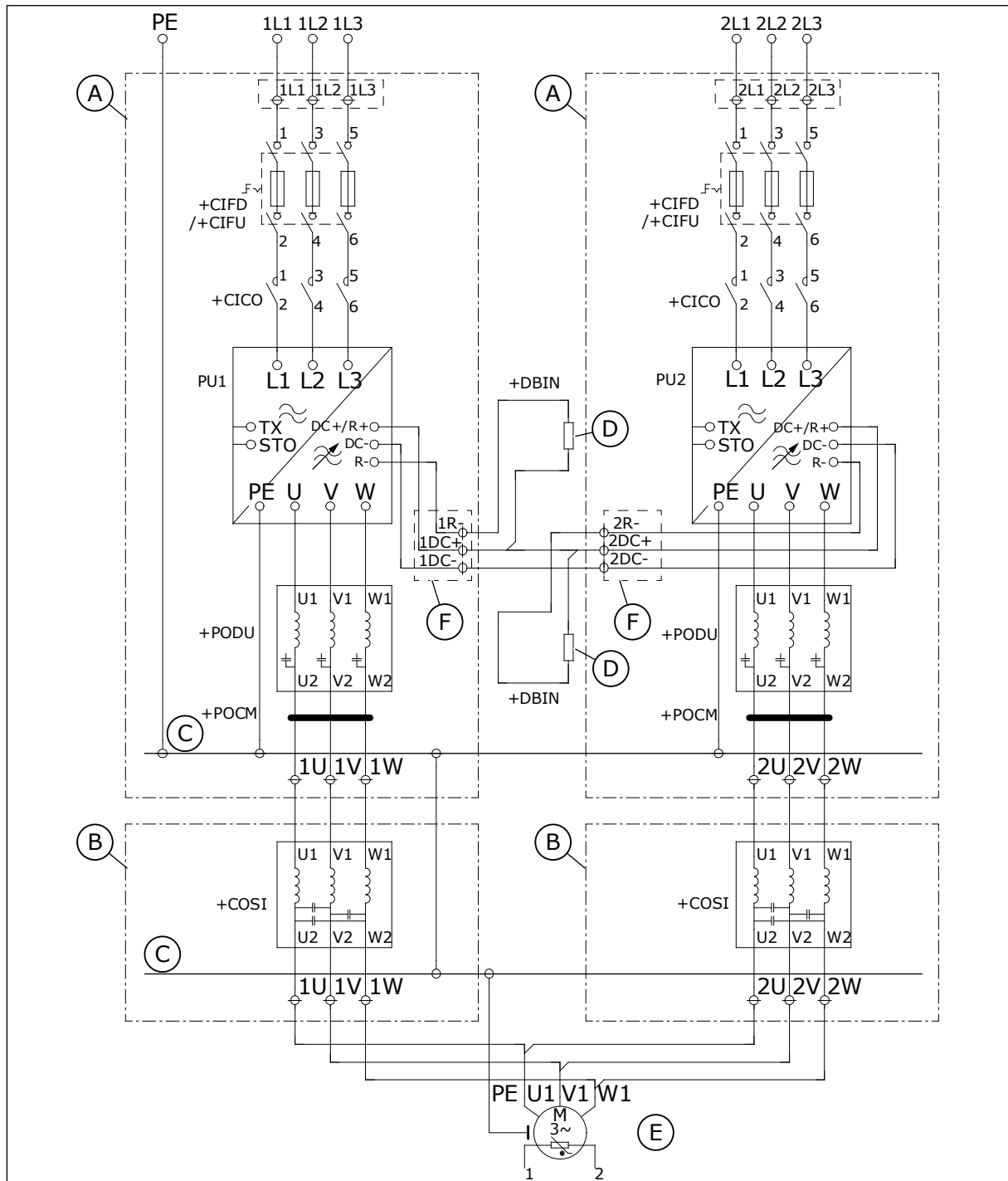

Fig. 34: Main circuit diagram of the cabinet, MR11 and MR12

- A. Main cabinet
- B. Sine filter cabinet
- C. PE bus
- D. Brake resistor (not included in delivery)
- E. Symmetrical motor cabling. The cables must have the same length from the power unit to a common point of coupling.
- F. Only in MR12

The minimum length of motor cables from the power unit to a common point of coupling is 10 m. When a du/dt filter is used, the cables can be less than 10 m long.

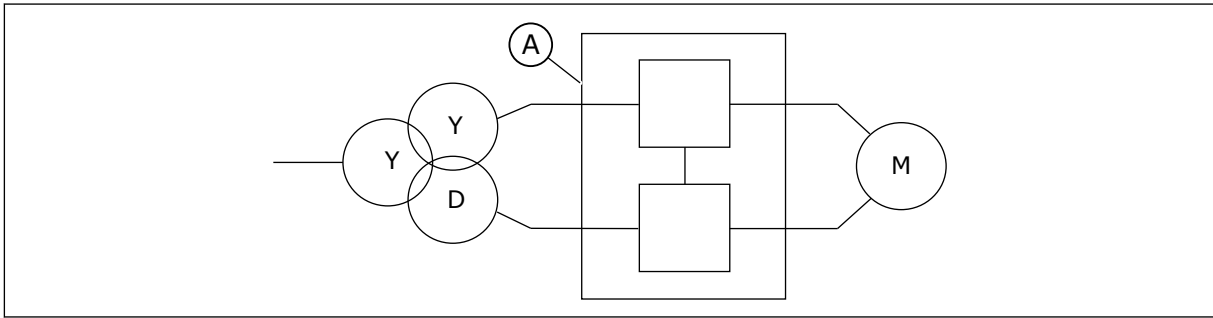

Fig. 35: The 12-pulse operation of MR11 and MR12

A. The MR12 drive

With MR11 and MR12 you can also use a 12-pulse connection to reduce the harmonics level in the supply side of the drive. In the 12-pulse connection, the parallel drives are cabled to the transformer's secondary windings that have a 30-degree phase shift.

5.1.2 CABLES AND FUSES

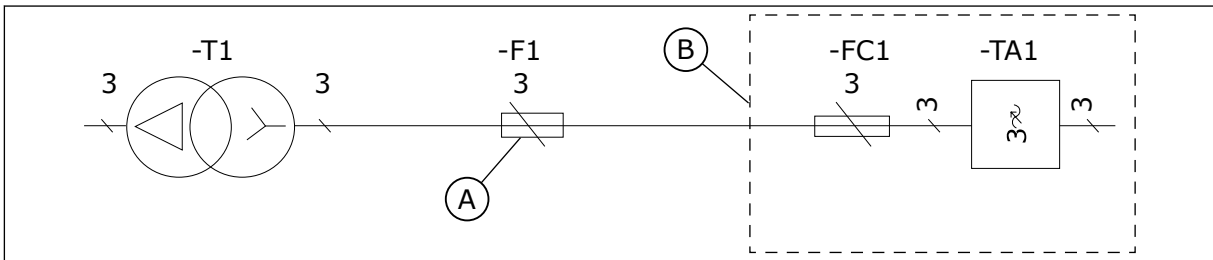

Fig. 36: The location of the fuses, MR8-MR10

A. The mains fuses

B. The cabinet

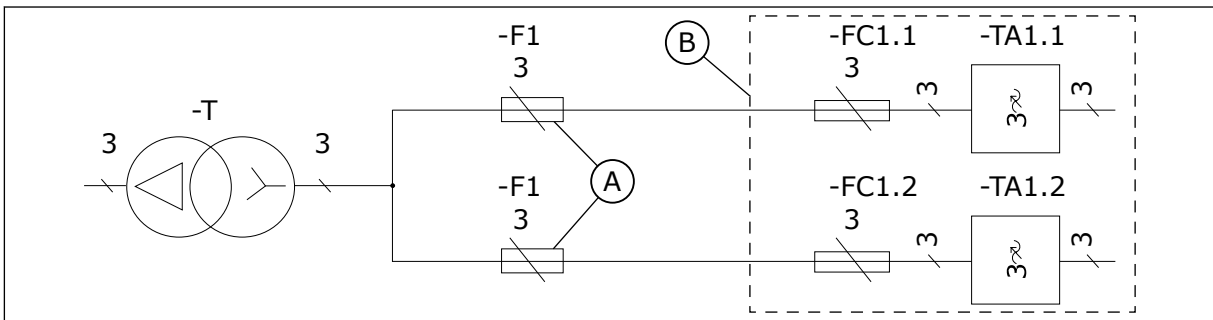

Fig. 37: The location of the fuses, MR11 and MR12

A. The mains fuses

B. The cabinet

5.1.3 CABLE AND FUSE SIZES, IEC

We recommend the fuse type gG/gL (IEC 60269-1) for mains fuses (-F1). Use only fuses that have a sufficient voltage rating according to the mains voltage. Do not use larger fuses than what is recommended in Table 11.

**NOTE!**

The overcurrent protection of parallel cables must be done with separate fuses.

Make sure that the operation time of the fuse is less than 0.4 seconds. The operation time agrees with the fuse type and the impedance of the supply circuit.

The table also shows the typical symmetrically shielded copper and aluminum types of the cables that can be used with the AC drive.

**NOTE!**

The mains cable and fuse sizes are valid up to a cable length of 100 m, with mains $I_K = 20$ kA.

The drive is equipped with fast acting aR-type fuses (-FC1) (see *Table 13*, *Table 14*, *Table 15* and *Table 16*). Do not use other fuses than these.

The dimensions of the cables agree with the requirements of the standards EN 60204-1 and IEC 60364-5-52: 2001.

- The cables are PVC-isolated.
- The maximum ambient temperature is +30 °C.
- The maximum temperature of the cable surface is +70 °C.
- The maximum number of parallel cables on a ladder type tray is 9 side by side.

In other conditions, when you select the dimensions of the cables, refer to local safety regulations, the input voltage and the load current of the drive.

Table 11: The recommended cables and fuses in 380-500 V (IEC)

Enclosure size	Type	IL [A]	Mains fuse (gG/gL) [A]	Mains and motor cable (Cu/Al) [mm ²]	Mains and motor cable terminals, bolt size	Grounding terminal, bolt size
MR8	0140 5	140	160	{3x70+35} (Cu) {3x95+29} (Al)	M8	M8
	0170 5	170	200	{3x95+50} (Cu) {3x150+41} (Al)	M8	M8
	0205 5	205	250	{3x120+70} (Cu) {3x185+57} (Al)	M8	M8
MR9A	0261 5	261	315	{3x185+95} (Cu) 2x{3x120+41} (Al)	M10	M8
	0310 5	310	355	2x{3x95+50} (Cu) 2x{3x120+41} (Al)	M10	M8
MR9B	0386 5	385	400	{3x120+70} (Cu) 2x{3x185+57} (Al)	M10	M8
MR10	0385 5	385	400	2x{3x120+70} (Cu) 2x{3x185+57} (Al)	M12	M8
	0460 5	460	500	2x{3x150+70} (Cu) 2x{3x240+72} (Al)	M12	M8
	0520 5	520	630	2x{3x185+95} (Cu) 3x{3x150+41} (Al)	M12	M8
	0590 5	590	630	2x{3x240+120} (Cu) 3x{3x185+57} (Al)	M12	M8
MR11	0651 5	650	2 x 355	4x{3x95+50} (Cu) 4x{3x120+41} (Al)	M10	M8
	0731 5	730	2 x 400	4x{3x95+50} (Cu) 4x{3x150+41} (Al)	M10	M8

Table 11: The recommended cables and fuses in 380-500 V (IEC)

Enclosure size	Type	IL [A]	Mains fuse (gG/gL) [A]	Mains and motor cable (Cu/Al) [mm ²]	Mains and motor cable terminals, bolt size	Grounding terminal, bolt size
MR12	0650 5	650	2 x 355	4x(3x95+50) (Cu) 4x(3x120+41) (Al)	M12	M8
	0730 5	730	2 x 400	4x(3x95+50) (Cu) 4x(3x150+41) (Al)	M12	M8
	0820 5	820	2 x 500	4x(3x120+70) (Cu) 4x(3x185+57) (Al)	M12	M8
	0920 5	920	2 x 500	4x(3x150+70) (Cu) 4x(3x240+72) (Al)	M12	M8
	1040 5	1040	2 x 630	4x(3x185+95) (Cu) 6x(3x150+41) (Al)	M12	M8
	1180 5	1180	2 x 630	4x(3x240+120) (Cu) 6x(3x185+57) (Al)	M12	M8

Table 12: The recommended cables and fuses in 525-690 V (IEC)

Enclosure size	Type	IL [A]	Mains fuse (gG/gL) [A]	Mains and motor cable (Cu/Al) [mm ²]	Mains and motor cable terminals, bolt size	Grounding terminal, bolt size
MR8	0080 7	80	100	3x35+16 (Cu) 3x50+21 (Al)	M8	M8
	0100 7	100	125	3x50+25 (Cu) 3x70+21 (Al)	M8	M8
	0125 7	125	160	3x70+35 (Cu) 3x95+29 (Al)	M8	M8
MR9A	0144 7	144	160	3x70+35 (Cu) 3x120+41 (Al)	M10	M8
	0170 7	170	200	3x95+50 (Cu) 3x150+41 (Al)	M10	M8
	0208 7	208	250	3x120+70 (Cu) 3x185+57 (Al)	M10	M8
MR9B	0262 7	261	315	3x185+95 (Cu) 2x(3x95+29) (Al)	M10	M8
MR10	0261 7	261	315	3x185+95 (Cu) 2x(3x95+29) (Al)	M12	M8
	0325 7	325	355	3x240+120 (Cu) 2x(3x120+41) (Al)	M12	M8
	0385 7	385	400	2x(3x120+70) (Cu) 2x(3x185+57) (Al)	M12	M8
	0416 7	416	450	2x(3x120+70) (Cu) 2x(3x185+57) (Al)	M12	M8
MR11	0461 7	460	2 x 315	2x(3x150+70) (Cu) 2x(3x240+72) (Al)	M10	M8
	0521 7	520	2 x 315	2x(3x185+95) (Cu) 4x(3x95+29) (Al)	M10	M8

Table 12: The recommended cables and fuses in 525-690 V (IEC)

Enclosure size	Type	IL [A]	Mains fuse (gG/gL) [A]	Mains and motor cable (Cu/Al) [mm ²]	Mains and motor cable terminals, bolt size	Grounding terminal, bolt size
MR12	0460 7	460	2 x 315	2x(3x150+70) (Cu) 2x(3x240+72) (Al)	M12	M8
	0520 7	520	2 x 315	2x(3x185+95) (Cu) 4x(3x95+29) (Al)	M12	M8
	0590 7	590	2 x 315	4x(3x70+35) (Cu) 4x(3x120+41) (Al)	M12	M8
	0650 7	650	2 x 355	4x(3x95+50) (Cu) 4x(3x150+41) (Al)	M12	M8
	0750 7	750	2 x 400	4x(3x120+70) (Cu) 4x(3x150+41) (Al)	M12	M8
	0820 7	820	2 x 425	4x(3x120+70) (Cu) 4x(3x185+57) (Al)	M12	M8

Table 13: Drive fuses, 380-500 V, Mersen (IEC)

Enclosure size	Type	IL [A]	Catalogue number of the fuse	Fuse rating [A]	Number of fuses needed	Fuse size	Minimum prospective short circuit current [A]
MR8	0140 5	140	NH1UD69V400PV	400	3	1	2800
	0170 5	170	NH1UD69V400PV	400	3	1	2800
	0205 5	205	NH1UD69V400PV	400	3	1	2800
MR9A	0261 5	261	NH2UD69V500PV	500	3	2	3300
	0310 5	310	NH2UD69V700PV	700	3	2	5800
MR9B	0386 5	385	NH2UD69V700PV	700	3	2	5800
MR10	0385 5	385	NH2UD69V700PV	700	3	2	5800
	0460 5	460	NH3UD69V800PV	800	3	3	6000
	0520 5	520	NH3UD69V1000PV	1000	3	3	8500
	0590 5	590	PC73UD90V10CPA	1000	3	3	13000
MR11	0651 5	650	NH2UD69V700PV	700	6	2	5800
	0731 5	730	NH2UD69V700PV	700	6	2	5800
MR12	0650 5	650	NH2UD69V700PV	700	6	2	5800
	0730 5	730	NH2UD69V700PV	700	6	2	5800
	0820 5	820	NH3UD69V800PV	800	6	3	6000
	0920 5	920	NH3UD69V1000PV	1000	6	3	8500
	1040 5	1040	NH3UD69V1000PV	1000	6	3	8500
	1180 5	1180	PC73UD90V10CPA	1000	6	3	13000

Table 14: Drive fuses, 525-690 V, Mersen (IEC)

Enclosure size	Type	IL [A]	Catalogue number of the fuse	Fuse rating [A]	Number of fuses needed	Fuse size	Minimum prospective short circuit current [A]
MR8	0080 7	80	NH1UD69V200PV	200	3	1	1000
	0100 7	100	NH1UD69V200PV	200	3	1	1000
	0125 7	125	NH1UD69V200PV	200	3	1	1000
MR9A	0144 7	144	NH1UD69V400PV	400	3	1	2800
	0170 7	170	NH1UD69V400PV	400	3	1	2800
	0208 7	208	NH1UD69V400PV	400	3	1	2800
MR9B	0262 7	261	NH2UD69V500PV	500	3	2	3400
MR10	0261 7	261	NH2UD69V500PV	500	3	2	3400
	0325 7	325	NH2UD69V500PV	500	3	2	3400
	0385 7	385	NH2UD69V700PV	700	3	2	5800
	0416 7	416	NH3UD69V800PV	800	3	3	6000
MR11	0461 7	460	NH2UD69V500PV	500	6	2	3400
	0521 7	520	NH2UD69V500PV	500	6	2	3400
MR12	0460 7	460	NH2UD69V500PV	500	6	2	3400
	0520 7	520	NH2UD69V500PV	500	6	2	3400
	0590 7	590	NH2UD69V500PV	500	6	2	3400
	0650 7	650	NH2UD69V700PV	700	6	2	5800
	0750 7	750	NH2UD69V700PV	700	6	2	5800
	0820 7	820	NH3UD69V800PV	800	6	3	6000

Table 15: Drive fuses, 380-500 V, Bussmann (IEC)

Enclosure size	Type	IL [A]	Catalogue number of the fuse	Fuse rating [A]	Number of fuses needed	Fuse size	Minimum prospective short circuit current [A]
MR8	0140 5	140	170M3819D	400	3	1	2400
	0170 5	170	170M3819D	400	3	1	2400
	0205 5	205	170M3819D	400	3	1	2400
MR9A	0261 5	261	170M5812D	630	3	2	4000
	0310 5	310	170M5812D	630	3	2	4000
MR9B	0386 5	385	170M5814D	800	3	2	5700
MR10	0385 5	385	170M5814D	800	3	2	5700
	0460 5	460	170M6814D	1000	3	3	7500
	0520 5	520	170M6892D	1100	3	3	8500
	0590 5	590	170M8554D	1250	3	3	11000
MR11	0651 5	650	170M5814D	800	6	2	5700
	0731 5	730	170M5814D	800	6	2	5700
MR12	0650 5	650	170M5814D	800	6	2	5700
	0730 5	730	170M5814D	800	6	2	5700
	0820 5	820	170M6814D	1000	6	3	7500
	0920 5	920	170M6814D	1000	6	3	7500
	1040 5	1040	170M6892D	1100	6	3	8500
	1180 5	1180	170M8554D	1250	6	3	11000

Table 16: Drive fuses, 525-690 V, Bussmann (IEC)

Enclosure size	Type	IL [A]	Catalogue number of the fuse	Fuse rating [A]	Number of fuses needed	Fuse size	Minimum prospective short circuit current [A]
MR8	0080 7	80	170M3816D	250	3	1	1300
	0100 7	100	170M3816D	250	3	1	1300
	0125 7	125	170M3816D	250	3	1	1300
MR9A	0144 7	144	170M3819D	400	3	1	2400
	0170 7	170	170M3819D	400	3	1	2400
	0208 7	208	170M3819D	400	3	1	2400
MR9B	0262 7	261	170M5812D	630	3	2	4000
MR10	0261 7	261	170M5812D	630	3	2	4000
	0325 7	325	170M5812D	630	3	2	4000
	0385 7	385	170M5814D	800	3	2	5700
	0416 7	416	170M6814D	1000	3	3	7500
MR11	0461 7	460	170M5812D	630	6	2	4000
	0521 7	520	170M5812D	630	6	2	4000
	0460 7	460	170M5812D	630	6	2	4000
MR12	0520 7	520	170M5812D	630	6	2	4000
	0590 7	590	170M5812D	630	6	2	4000
	0650 7	650	170M5814D	800	6	2	5700
	0750 7	750	170M5814D	800	6	2	5700
	0820 7	820	170M6814D	1000	6	3	7500

5.1.4 CABLE AND FUSE SIZES, NORTH AMERICA

The solid state short circuit protection does not supply protection for the branch circuit of the AC drive. To supply the branch circuit protection, refer to the local electric codes.

We recommend the fuse class T or J (UL & CSA) to supply a branch circuit protection. To make a selection of the fuse voltage rating, refer to the mains. Refer also to local regulations, cable installation conditions and cable specification. Do not use larger fuses than what is recommended in *Table 17*.

The branch circuit protection can be supplied by a listed circuit breaker according to local electric code as an alternative to Class T or J fuses.

The dimensions of the cables must agree with the requirements of the local electric codes.

For important information on the requirements of the grounding conductor, see the local electric codes.

For the correction factors for each temperature, see the instructions of the local electric codes.

The UL approval is valid for input voltage up to 600 V.

Table 17: The recommended cables and terminal lugs in 380-500 V (NAM)

Enclosure size	Type	IL (A)	Mains and motor cable (Cu) [AWG/kcmil]	Mains and motor cable termination, Panduit terminal part number	Grounding terminal, bolt and lug size
MR8	0140 5	140	(3x2/0+3x10)	LCAX2/0-38-X	P10-56R-L
	0170 5	170	(3x4/0+3x8)	LCAX4/0-38-X	LCAX8-56-L
	0205 5	205	(3x262+3x6)	LCAX250-38-X	LCAX6-56-L
MR9A	0261 5	261	2x(3x2/0+3x10)	LCAX2/0-38-X	P10-56R-L
	0310 5	310	2x(3x4/0+3x8)	LCAX4/0-38-X	LCAX8-56-L
MR9B	0386 5	385	2x(3x262+3x6)	LCAX250-12-X	LCAX6-56-L
MR10	0385 5	385	2x(3x262+3x6)	LCAX250-12-X	LCAX6-56-L
	0460 5	460	2x(3x313+3x6)	LCAX300-12-6	LCAX6-56-L
	0520 5	520	2x(3x373+3x6)	LCAX350-12-6	LCAX6-56-L
	0590 5	590	3x(3x262+3x6)	LCAX250-12-X	LCAX6-56-L
MR11	0651 5	650	4x(3x4/0+3x8)	LCAX4/0-12-X	LCAX8-56-L
	0731 5	730	4x(3x4/0+3x8)	LCAX4/0-12-X	LCAX8-56-L
MR12	0650 5	650	4x(3x4/0+3x8)	LCAX4/0-12-X	LCAX8-56-L
	0730 5	730	4x(3x4/0+3x8)	LCAX4/0-12-X	LCAX8-56-L
	0820 5	820	4x(3x262+3x6)	LCAX250-12-X	LCAX6-56-L
	0920 5	920	4x(3x313+3x6)	LCAX300-12-6	LCAX6-56-L
	1040 5	1040	4x(3x373+3x6)	LCAX350-12-6	LCAX6-56-L
	1180 5	1180	6x(3x262+3x6)	LCAX250-12-X	LCAX6-56-L

Table 18: The recommended cables and terminal lugs in 525-690 V (NAM)

Enclosure size	Type	IL (A)	Mains and motor cable (Cu) [AWG/kcmil]	Mains and motor cable termination, Panduit terminal part number	Grounding terminal, bolt and lug size
MR8	0080 7	80	{3x2+3x10}	LCAX2-38-E	P10-56R-L
	0100 7	100	{3x1+3x10}	LCAX1-38-X	P10-56R-L
	0125 7	125	{3x2/0+3x10}	LCAX2/0-38-X	P10-56R-L
MR9A	0144 7	144	{3x4/0+3x8}	LCAX4/0-38-X	LCAX8-56-L
	0170 7	170	{3x4/0+3x8}	LCAX4/0-38-X	LCAX8-56-L
	0208 7	208	2x{3x1+3x10}	LCAX1-38-X	P10-56R-L
MR9B	0262 7	261	2x{3x2/0+3x10}	LCA2/0-12-X	P10-56R-L
MR10	0261 7	261	2x{3x2/0+3x10}	LCA2/0-12-X	P10-56R-L
	0325 7	325	2x{3x4/0+3x8}	LCAX4/0-12-X	LCAX8-56-L
	0385 7	385	2x{3x262+3x6}	LCAX250-12-X	LCAX6-56-L
	0416 7	416	2x{3x262+3x6}	LCAX250-12-X	LCAX6-56-L
MR11	0461 7	460	4x{3x1/0+3x10}	LCAX1/0-12-X	P10-56R-L
	0521 7	520	4x{3x2/0+3x10}	LCAX2/0-12-X	P10-56R-L
MR12	0460 7	460	4x{3x1/0+3x10}	LCAX1/0-12-X	P10-56R-L
	0520 7	520	4x{3x2/0+3x10}	LCAX2/0-12-X	P10-56R-L
	0590 7	590	4x{3x4/0+3x8}	LCAX4/0-12-X	LCAX8-56-L
	0650 7	650	4x{3x4/0+3x8}	LCAX4/0-12-X	LCAX8-56-L
	0730 7	730	4x{3x4/0+3x8}	LCAX4/0-12-X	LCAX8-56-L
	0820 7	820	4x{3x262+3x6}	LCAX250-12-X	LCAX6-56-L

Table 19: Drive fuses, 380-500 V, Mersen (NAM)

Enclosure size	Type	IL [A]	Catalogue number of the fuse	Fuse rating [A]	Number of fuses needed	Fuse size	Minimum prospective short circuit current [A]
MR8	0140 5	140	PC30UD69V350TF	350	3	PSC30	2500
	0170 5	170	PC30UD69V350TF	350	3	PSC30	2500
	0205 5	205	PC30UD69V350TF	350	3	PSC30	2500
MR9A	0261 5	261	PC30UD69V550TF	550	3	PSC30	4600
	0310 5	310	PC30UD69V550TF	550	3	PSC30	4600
MR9B	0386 5	385	PC30UD69V550TF	550	3	PSC30	4600
MR10	0385 5	385	PC32UD69V800TF	800	3	PSC32	6800
	0460 5	460	PC32UD69V800TF	800	3	PSC32	6800
	0520 5	520	PC32UD69V1000TF	1000	3	PSC32	9400
	0590 5	590	PC32UD69V1000TF	1000	3	PSC32	9400
MR11	0651 5	650	PC30UD69V550TF	550	6	PSC30	4700
	0731 5	730	PC30UD69V550TF	550	6	PSC30	4700
MR12	0650 5	650	PC32UD69V630TF	630	6	PSC32	4700
	0730 5	730	PC32UD69V630TF	630	6	PSC32	4700
	0820 5	820	PC32UD69V800TF	800	6	PSC32	6800
	0920 5	920	PC32UD69V800TF	800	6	PSC32	6800
	1040 5	1040	PC32UD69V1000TF	1000	6	PSC32	9400
	1180 5	1180	PC32UD69V1000TF	1000	6	PSC32	9400

Table 20: Drive fuses, 525-690 V, Mersen (NAM)

Enclosure size	Type	IL [A]	Catalogue number of the fuse	Fuse rating [A]	Number of fuses needed	Fuse size	Minimum prospective short circuit current [A]
MR8	0080 7	80	PC30UD69V200TF	200	3	PSC30	1100
	0100 7	100	PC30UD69V200TF	200	3	PSC30	1100
	0125 7	125	PC30UD69V200TF	200	3	PSC30	1100
MR9A	0144 7	144	PC30UD69V350TF	350	3	PSC30	2500
	0170 7	170	PC30UD69V350TF	350	3	PSC30	2500
	0208 7	208	PC30UD69V350TF	350	3	PSC30	2500
MR9B	0262 7	261	PC30UD69V400TF	400	3	PSC30	3100
MR10	0261 7	261	PC30UD69V500TF	500	3	PSC32	3300
	0325 7	325	PC30UD69V500TF	500	3	PSC32	3300
	0385 7	385	PC32UD69V630TF	630	3	PSC32	4700
	0416 7	416	PC32UD69V800TF	800	3	PSC32	6800
MR11	0461 7	460	PC30UD69V400TF	400	6	PSC30	3100
	0521 7	520	PC30UD69V400TF	400	6	PSC30	3100
MR12	0460 7	460	PC30UD69V500TF	500	6	PSC32	3300
	0520 7	520	PC30UD69V500TF	500	6	PSC32	3300
	0590 7	590	PC32UD69V500TF	500	6	PSC32	3300
	0650 7	650	PC32UD69V630TF	630	6	PSC32	4700
	0750 7	750	PC32UD69V630TF	630	6	PSC32	4700
	0820 7	820	PC32UD69V800TF	800	6	PSC32	6800

5.2 BRAKE RESISTOR CABLES

Table 21: Brake resistor cables, 380-500 V

Enclosure size	Type	IL [A]	Brake resistor cable (Cu) [mm ²]
MR8	0140 5	140	3x70+35
	0170 5	170	3x95+50
	0205 5	205	3x120+70
MR9A	0261 5	261	2x(3x70+35)
	0310 5	310	2x(3x95+50)
MR9B	0386 5	385	2x(3x95+50)
MR10	0385 5	385	2x(3x95+50)
	0460 5	460	
	0520 5	520	2x(3x120+70)
	0590 5	590	
MR11	0651 5	650	4x(3x95+50)
	0731 5	730	
MR12	0650 5	650	4x(3x95+50)
	0730 5	730	
	0820 5	820	
	0920 5	920	
	1040 5	1040	4x(3x120+70)
	1180 5	1180	

One of the cable conductors remains unconnected. Use a symmetrically shielded cable, the same type as with the mains and motor cables.



NOTE!

The different VACON® 100 applications have different functions. For example, the VACON® 100 FLOW does not have the dynamic braking or the brake resistor functions.

Table 22: Brake resistor cables, 525-690 V

Enclosure size	Type	IL [A]	Brake resistor cable (Cu) [mm ²]
MR8	0080 7	80	3x35+16
	0100 7	100	3x50+25
	0125 7	125	3x70+35
MR9A	0144 7	144	3x70+35
	0170 7	170	3x95+50
	0208 7	208	3x120+70
MR9B	0262 7	261	2x(3x70+35)
MR10	0261 7	261	2x(3x70+35)
	0325 7	325	
	0385 7	385	2x(3x95+50)
	0416 7	416	
MR11	0461 7	460	4x(3x70+35)
	0521 7	520	4x(3x70+35)
MR12	0460 7	460	4x(3x70+35)
	0520 7	520	
	0590 7	590	
	0650 7	650	
	0750 7	750	4x(3x95+50)
	0820 7	820	

One of the cable conductors remains unconnected. Use a symmetrically shielded cable, the same type as with the mains and motor cables.

**NOTE!**

The different VACON® 100 applications have different functions. For example, the VACON® 100 FLOW does not have the dynamic braking or the brake resistor functions.

5.3 PREPARING FOR THE CABLE INSTALLATION

- Before you start, make sure that none of the components of the AC drive is live. Read carefully the warnings in chapter 2 *Safety*.
- Make sure that the motor cables are sufficiently far from other cables.
- The motor cables must cross other cables at an angle of 90°.
- If it is possible, do not put the motor cables in long parallel lines with other cables.

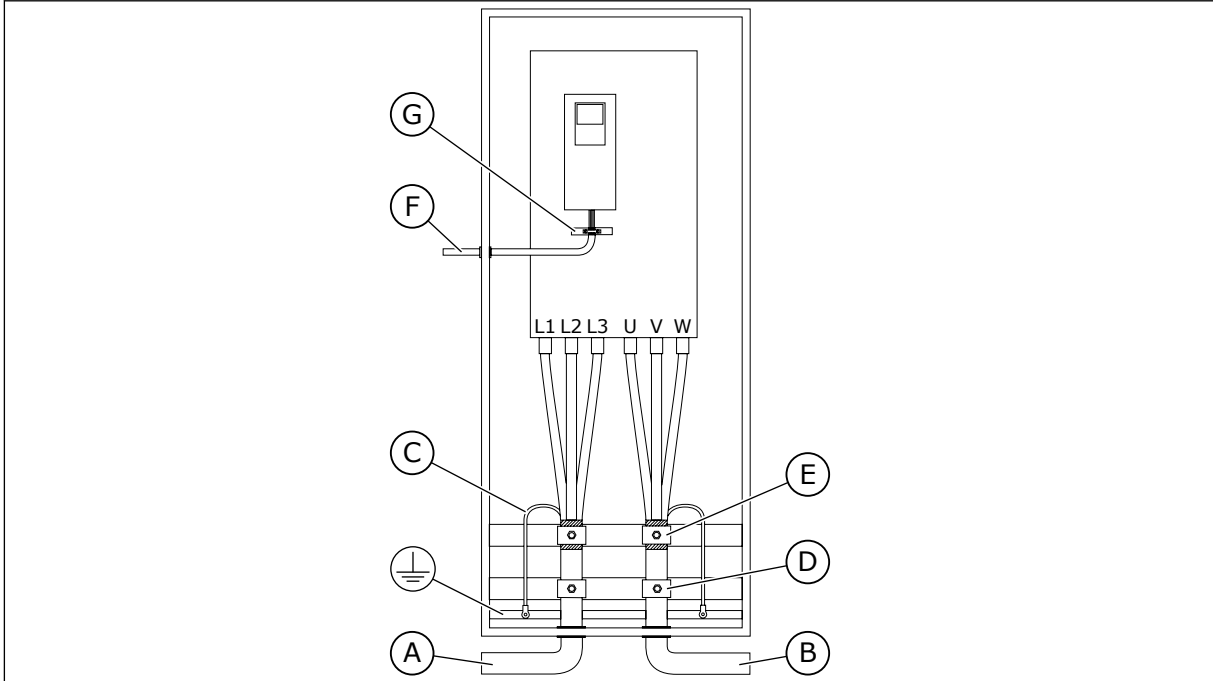

- A. The mains cables
- B. The motor cables
- C. The grounding conductor
- D. Pull relief
- E. The grounding clamp for cable shield, 360° grounding
- F. The control cable
- G. The grounding bar of the control cable

- Only use symmetrically EMC shielded motor cables.
- The maximum length of shielded motor cables is 200 m without sine filter (MR8-MR12).
- If the cable insulation checks are necessary, see chapter 7.3 for instructions.
- If the motor cables are in long parallel lines with other cables, obey the minimum distances.
- The minimum distances are also valid between the motor cables and the signal cables of other systems.

Table 23: The minimum distances between cables in long parallel lines

The distance between cables [m]	The length of the shielded cable [m]
0.3	≤ 50
1.0	≤ 200

5.4 CABLE INSTALLATION IN MR8-MR12

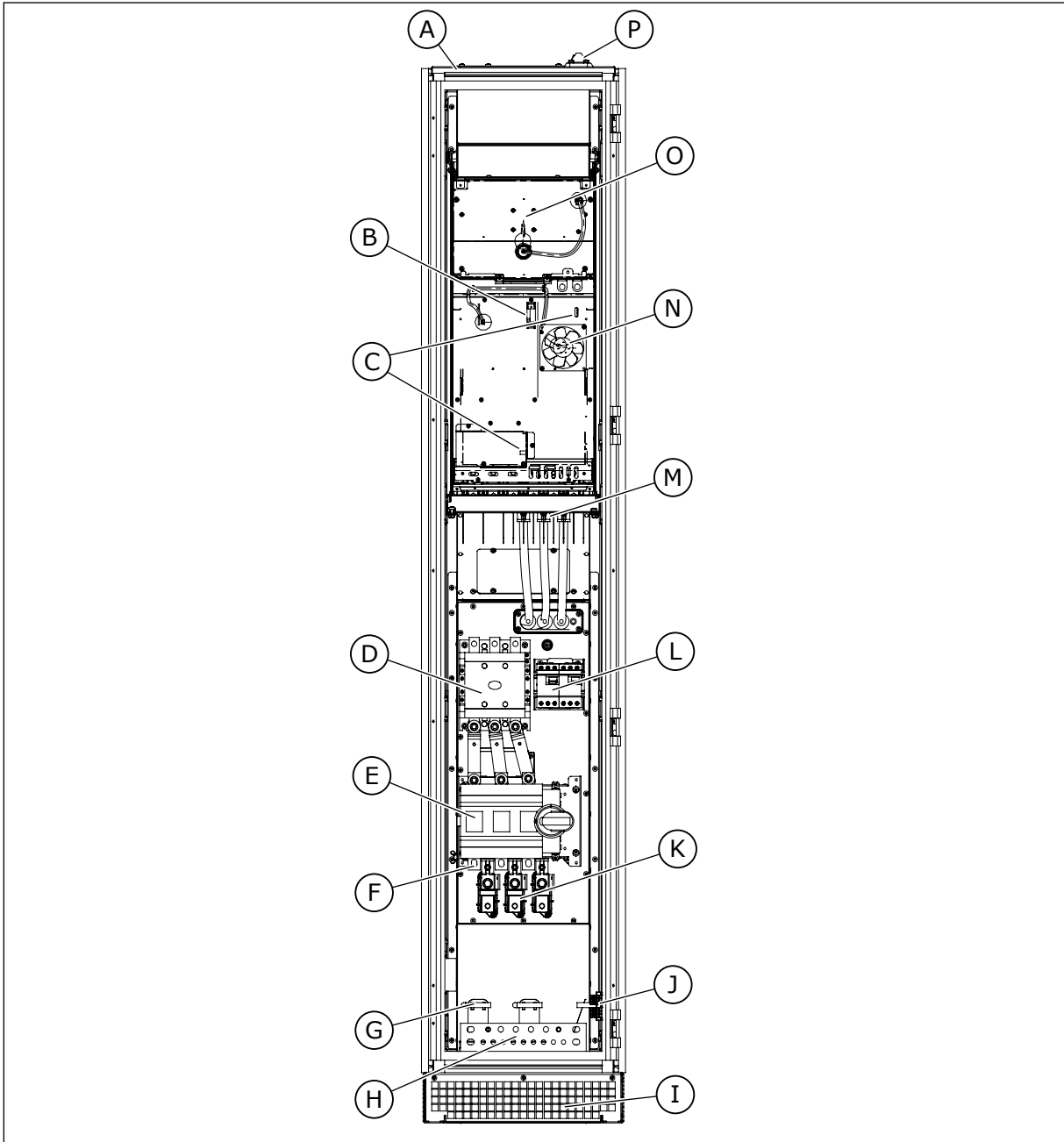

Fig. 38: The inside layout of MR8, without protective covers

- A. The output air grill
- B. The control connector of the power unit
- C. The EMC jumpers
- D. The contactor option
- E. The main switch option and the fuses
- F. The mains cable terminals
- G. The 360-degree grounding
- H. The PE bar
- I. Input air grill
- J. The terminals for the option +CAPU
- K. The motor cable terminals with the common mode and/or the du/dt filter options
- L. The options CAPT and CPIF
- M. The motor cable terminals, without the common mode and/or the du/dt filter options
- N. The internal fan for IP54
- O. The main fan
- P. The cable entry plate for control cables

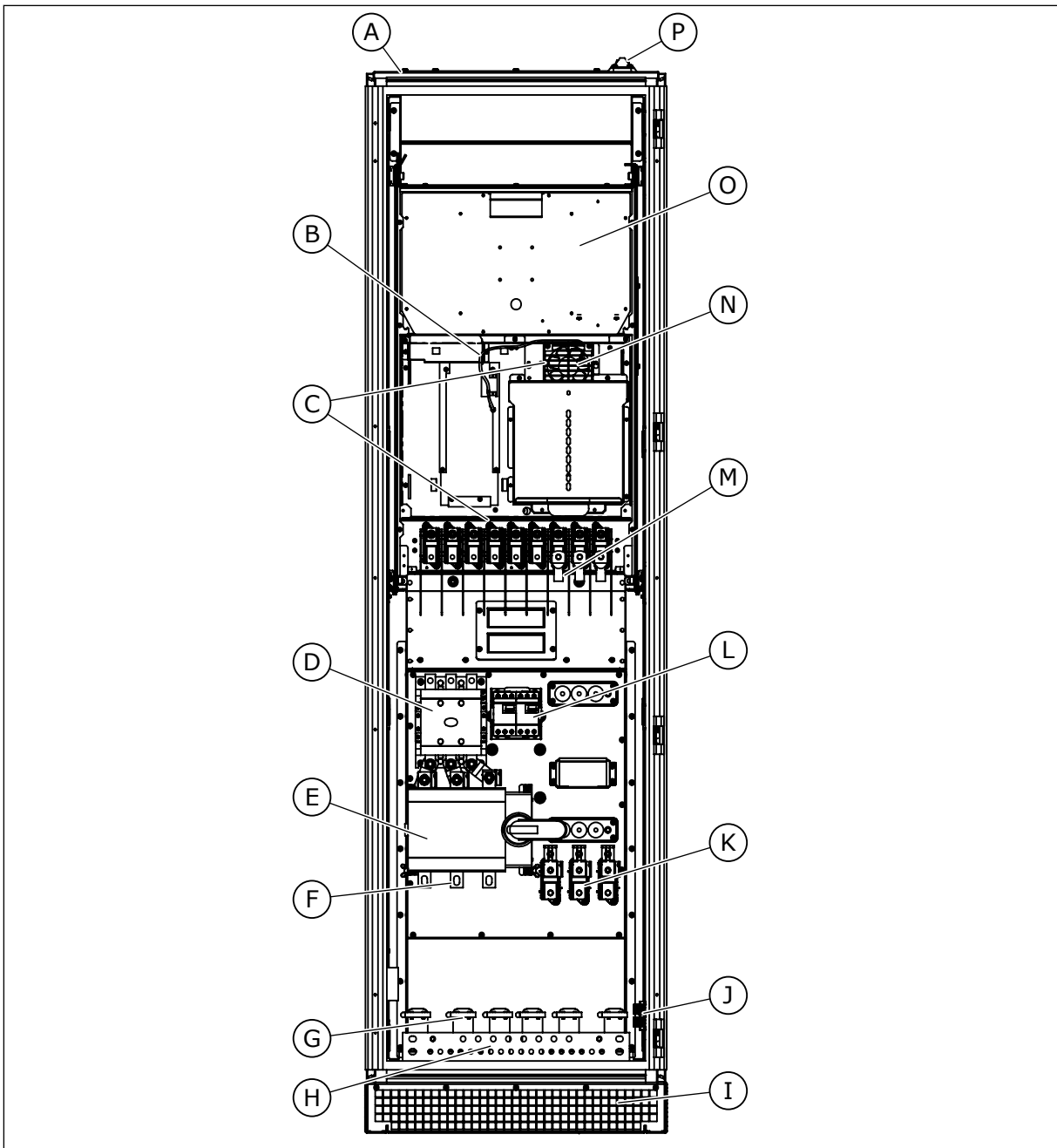

Fig. 39: The inside layout of MR9, without protective covers

- | | |
|--|--|
| <ul style="list-style-type: none"> A. The output air grill B. The control connector of the power unit C. The EMC jumpers D. The contactor option E. The main switch option and the fuses F. The mains cable terminals G. The 360-degree grounding H. The PE bar I. Input air grill J. The terminals for the option +CAPU | <ul style="list-style-type: none"> K. The motor cable terminals with the common mode and/or the du/dt filter options L. The options CAPT and CPIF M. The motor cable terminals, without the common mode and/or the du/dt filter options N. The internal fan for IP54 O. The main fan P. The cable entry plate for control cables |
|--|--|

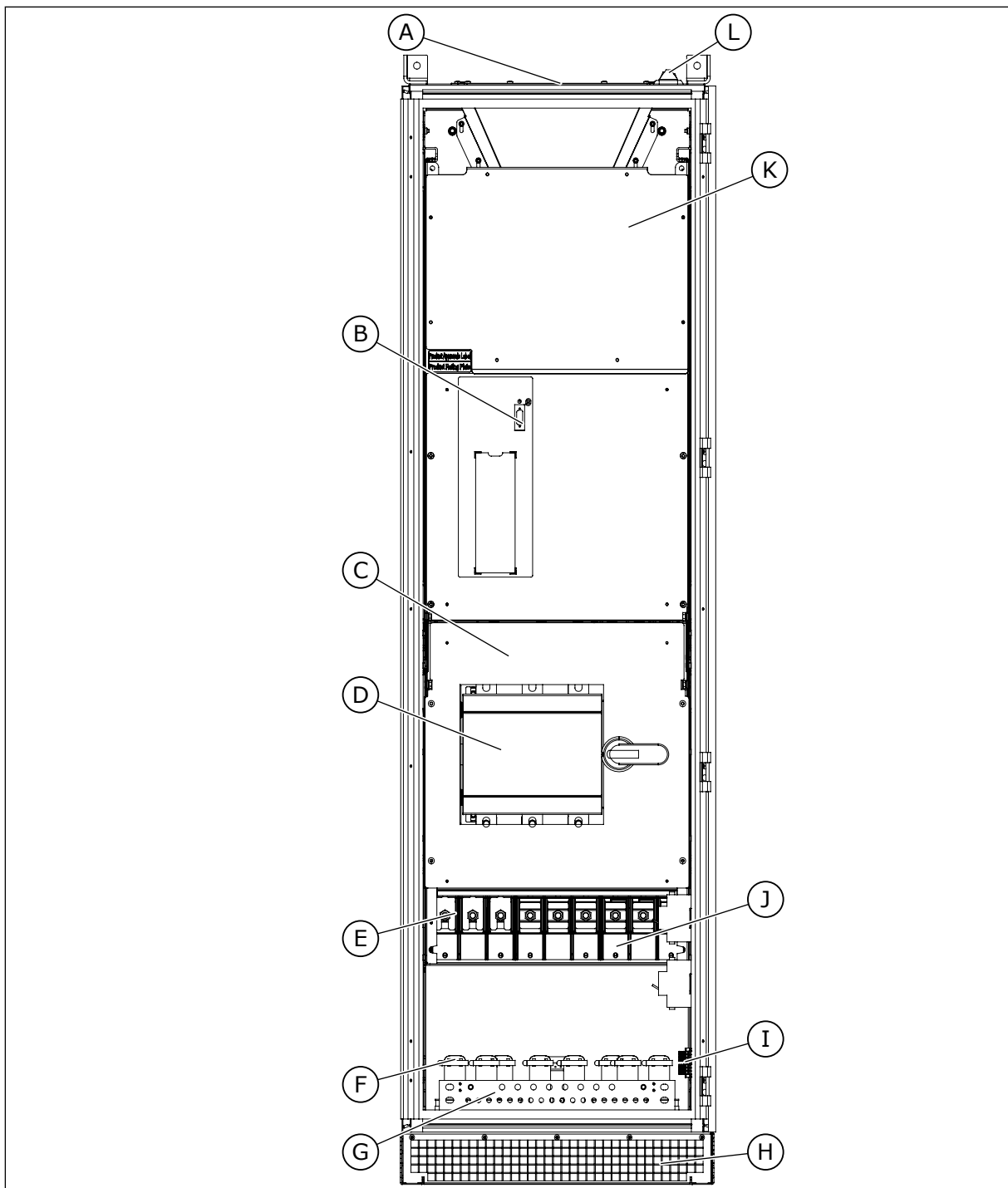

Fig. 40: The inside layout of MR10, without protective covers

- | | |
|--|---|
| A. The output air grill | G. The PE bar |
| B. The control connector of the power unit | H. Input air grill |
| C. The EMC jumper (behind the covers) | I. The terminals for the option +CAPU |
| D. The main switch option and the fuses | J. The motor cable terminals |
| E. The mains cable terminals | K. The service lid, and the main fan under it |
| F. The 360-degree grounding | L. The cable entry plate for control cables |

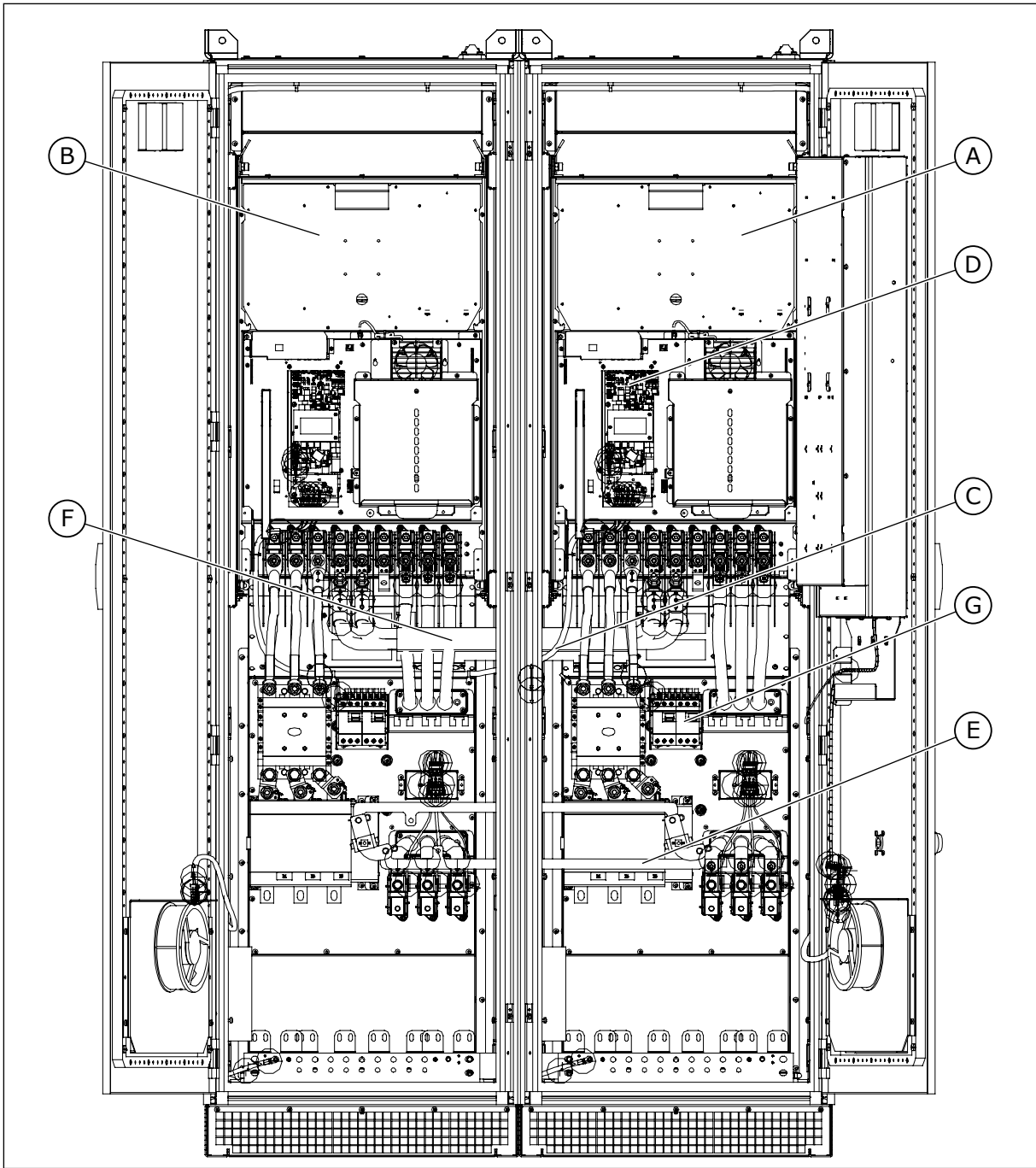

Fig. 41: The inside layout of MR11, without protective covers

- | | |
|--|--|
| <ul style="list-style-type: none"> A. The power unit 1 B. The power unit 2 C. Optical fiber cables D. The connector for control unit cable (in power unit 1) | <ul style="list-style-type: none"> E. The fuse switch linkage for the fuse switch option F. The DC link connection G. The auxiliary voltage transformer |
|--|--|

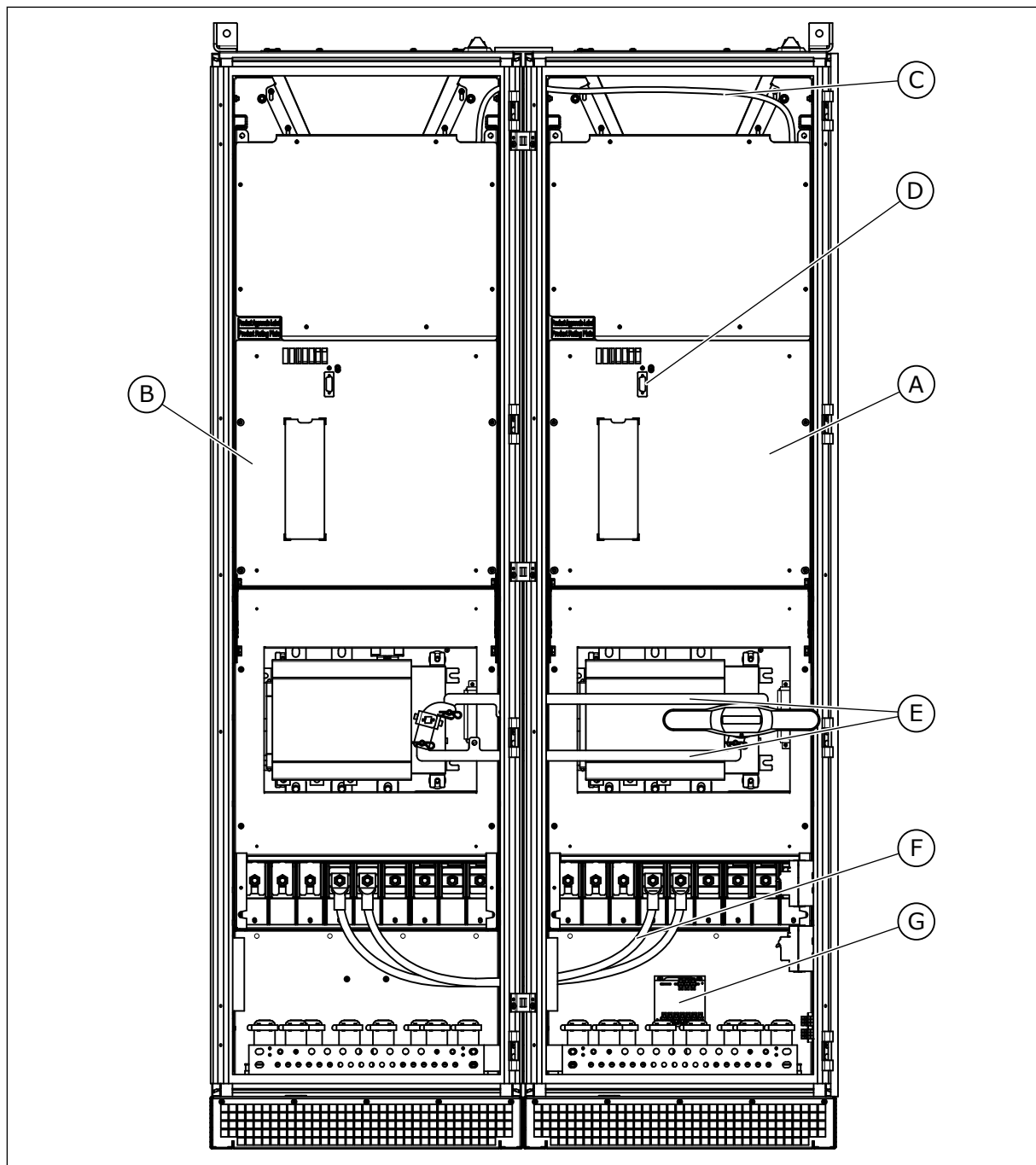

Fig. 42: The inside layout of MR12, without protective covers

- | | |
|---|--|
| A. Power unit 1 | E. The fuse switch linkage for the fuse switch option. |
| B. Power unit 2 | F. The DC link connection |
| C. Optical fibre cables | G. The auxiliary voltage transformer |
| D. The connector for control unit cable (in power unit 1) | |

INSTALLING THE CABLES

- 1 Open the cabinet door.

- 2 In MR12, if you have the fuse switch option, remove the the fuse switch linkage.
- 3 Remove the covers of the AC drive.
- 4 In IP54, cut the grommets open to move the cables through them.
 - a) Do not cut the grommet openings wider than what is necessary for the cables that you use.

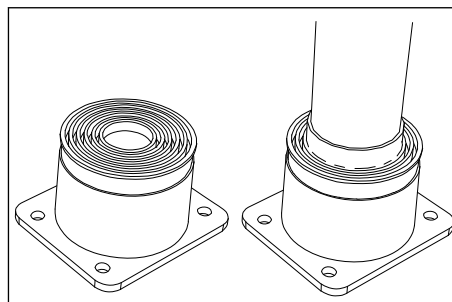

IP54 only

- 5 Put the cables into their places.
- 6 Strip the motor cable and the mains cable.
 - a) Keep the grounding conductor as short as possible, but so that it reaches the grounding bar.
- 7 Strip the brake resistor cable.
 - a) Keep the grounding conductor as short as possible, but so that it reaches the grounding bar.
- 8 Connect the stripped cables.
 - a) Connect the phase conductors of the mains cable and of the motor cable into the correct terminals. If you use a brake resistor cable, connect its conductors into the correct terminals.
 - b) Attach the grounding conductor of each cable to a grounding terminal with a grounding clamp for grounding conductor.
 - c) Make sure that the external grounding conductor is connected to the grounding bar. See chapter 2.4 *Grounding and earth fault protection*.

- 9 If you use many cables on one connector, put the cable lugs on top of each other.
- The picture shows the connection in MR8, MR9 and MR11.

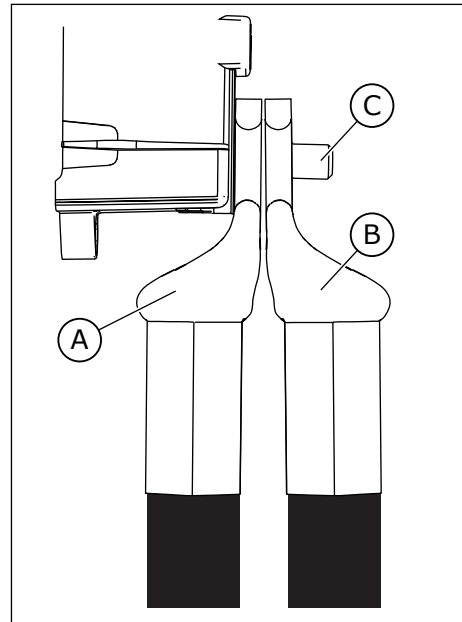

- A. The first cable lug
B. The second cable lug
C. The connector

10 If you use many cables on one connector, put the cable lugs on top of each other.

- The pictures show the connection in MR10 and MR12.
- The bolt holder of the connector keeps the bolt still when you turn the nut.

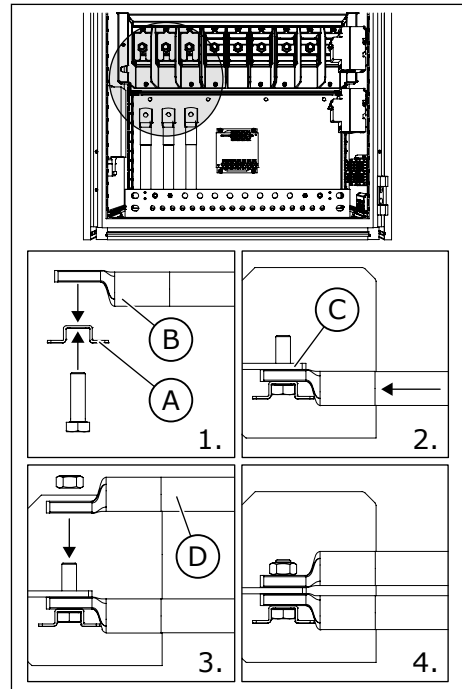

- A. The bolt holder of the connector
- B. The first cable lug
- C. The connector
- D. The second cable lug

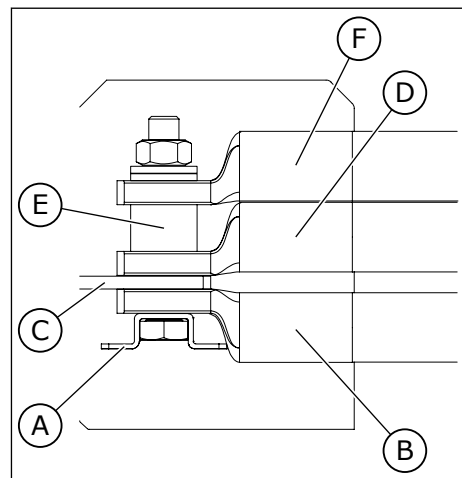

- A. The bolt holder of the connector
- B. The first cable lug
- C. The connector
- D. The second cable lug
- E. The connection bush
- F. The third cable lug

- 11 Expose the shield of all 3 cables to make a 360-degree connection with the metallic grounding clamps for cable shield.

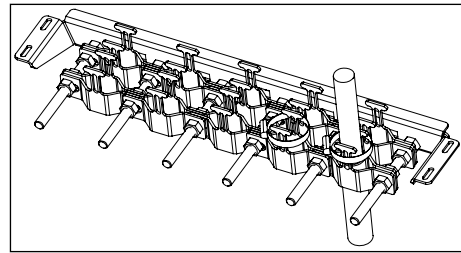

IP21

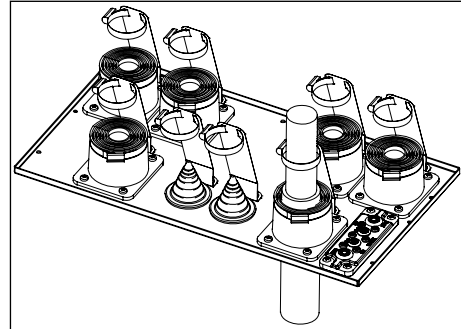

IP54

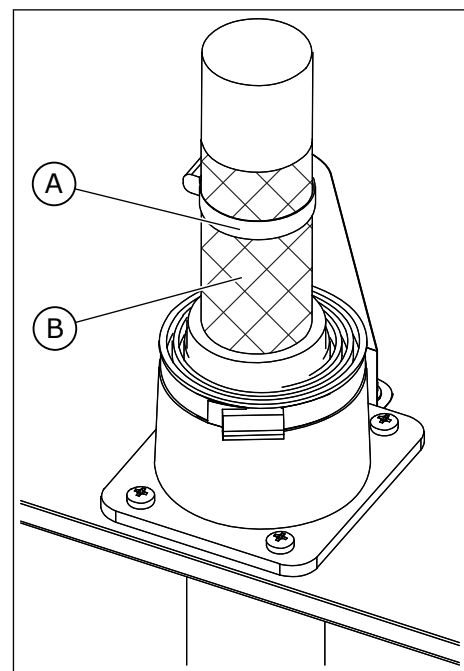

- A. The grounding clamp for cable shield
- B. The shield of the cable

- 12 Attach the terminal cover, and then the extension box cover.
- 13 Close the cabinet door.

- 14 Make sure that the grounding conductor is connected to the motor and also to the terminals that are identified with ⊕ .
- a) To obey the requirements of the standard EN61800-5-1, obey the instructions in chapter 2.4 *Grounding and earth fault protection*.

Table 24: Tightening torques of the terminals, MR8-MR12

Enclosure size	Type	Tightening torque: the mains and motor cable terminals		Tightening torque: the grounding terminals	
		[Nm]	lb-in.	[Nm]	lb-in.
MR8	0140 5-0205 5 0080 7-0125 7	30-44 *	266-389 *	20	177
MR9	0261 5-0386 5 0144 7-0262 7	30-44 *	266-389 *	20	177
MR10	0385 5-0590 5 0261 7-0416 7	55-70	490-620	20	177
MR11	0651 5-0731 5 0461 7-0521 7	40-44 *	266-389 *	20	177
MR12	0650 5-1180 5 0460 7-0820 7	55-70	490-620	20	177

* = Counter torque is required for the mains cable terminals.

6 CONTROL COMPARTMENT

6.1 THE CONTROL COMPARTMENT OF THE ENCLOSED DRIVE

The enclosed drive has a door-mounted control compartment, separated from the cabinet section, for the mains and motor cable terminals. You can have an access to the control compartment through a separate door located on the cabinet door.

On the inside of the control compartment door, you can find the order-specific documents.

Make sure that the control cables are long enough to prevent tight bends in the cables between the control compartment and the frame of the drive.

The control compartment contains these items:

- the control unit
- the control panel
- the option boards
- the optional auxiliary components and the related wires
- the terminals for internal connections
- the terminals for control cabling
- the order-specific documentation (on the inside of the door)
- the optional buttons and signal lights (on the door)

Connect the cables of the option boards OPTB2, OPTB4, OPTB5, OPTF3 and OPTF4 (depending on the configuration of the drive) as default to the terminals for control cabling – XD2 on the control compartment.

Do not connect the cables of the fieldbus boards to the -XD2 terminals, but directly to the control terminals or the Ethernet terminal on the control unit. Connect the analogue signals (for example reference signals and temperature signals) and the fieldbus cables directly to the correct option board.

		Standard I/O board				
		Terminal	Signal	Description		
Reference potentiometer 1...10kΩ		1	+10 Vref	Reference output		
		2	AI1+	Analogue input, voltage or current	Frequency reference	
		3	AI1-	Analogue input common, (current)		
		4	AI2+	Analogue input, voltage or current	Frequency reference	
		5	AI2-	Analogue input common, (current)		
2-wire transmitter Actual value I = (0)4...20mA		6	24Vout	24V auxiliary voltage		
		7	GND	I/O ground		
	8	DI1	Digital input 1	Start forward		
	9	DI2	Digital input 2	Start reverse		
	10	DI3	Digital input 3	External fault		
	11	CM	Common for DI1-DI6	*)		
	12	24Vout	24V auxiliary voltage			
	13	GND	I/O ground			
	14	DI4	Digital input 4	DI4 Open Closed	DI5 Open Closed	Freq. ref. Analog input 1 Preset Freq. 1 Preset Freq. 2 Preset Freq. 3
	15	DI5	Digital input 5			
	16	DI6	Digital input 6	Fault reset		
	17	CM	Common for DI1-DI6	*)		
	18	AO1+	Analogue signal (+output)	Output frequency		
19	AO1-/GND	Analogue output common / I/O ground				
	30	+24Vin	24V auxiliary input voltage			
	A	RS485	Serial bus, negative	Modbus RTU BACnet, N2		
B	RS485	Serial bus, positive				
	21	RO1 NC	Relay output 1	RUN		
	22	RO1 CM				
	23	RO1 NO				
	24	RO2 NC	Relay output 2	FAULT		
	25	RO2 CM				
	26	RO2 NO				
	32	RO3 CM	Relay output 3	READY		
	33	RO3 NO				

Fig. 43: The signals of the control terminals on the standard I/O board, and a connection example. If you include the option code +SBF4 in your order, the relay output 3 is replaced with a thermistor input.

* = You can isolate digital inputs from ground with a DIP switch.

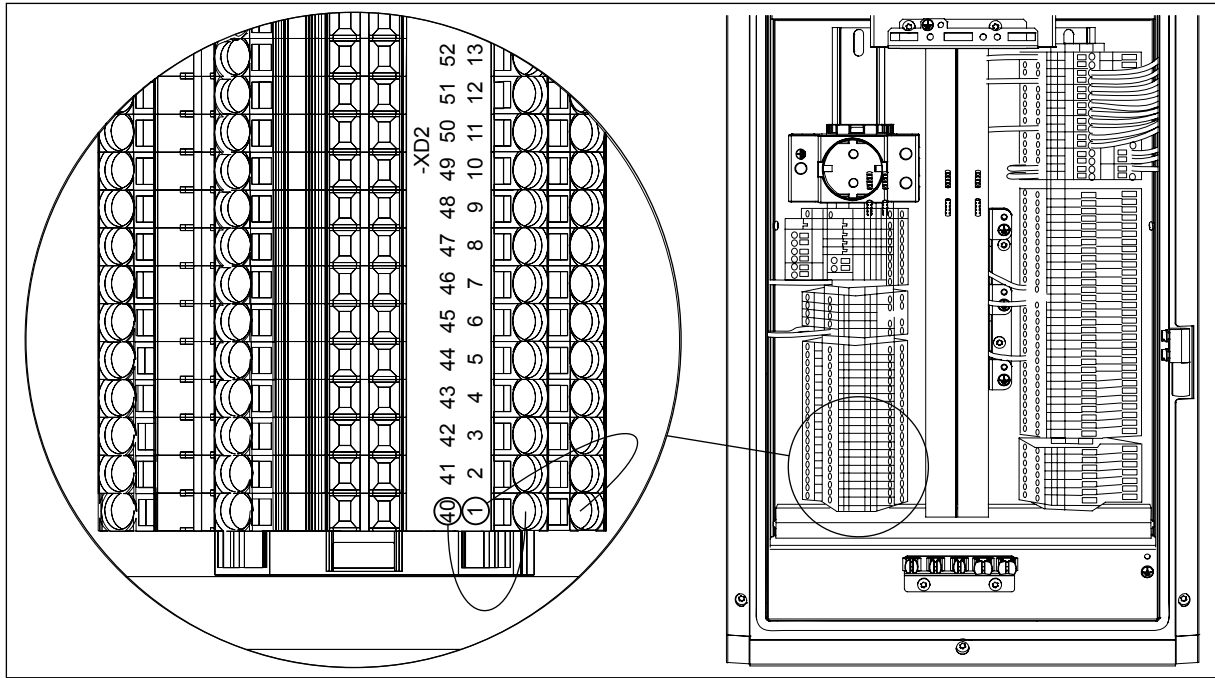

Fig. 44: The markings of the extended I/O terminals

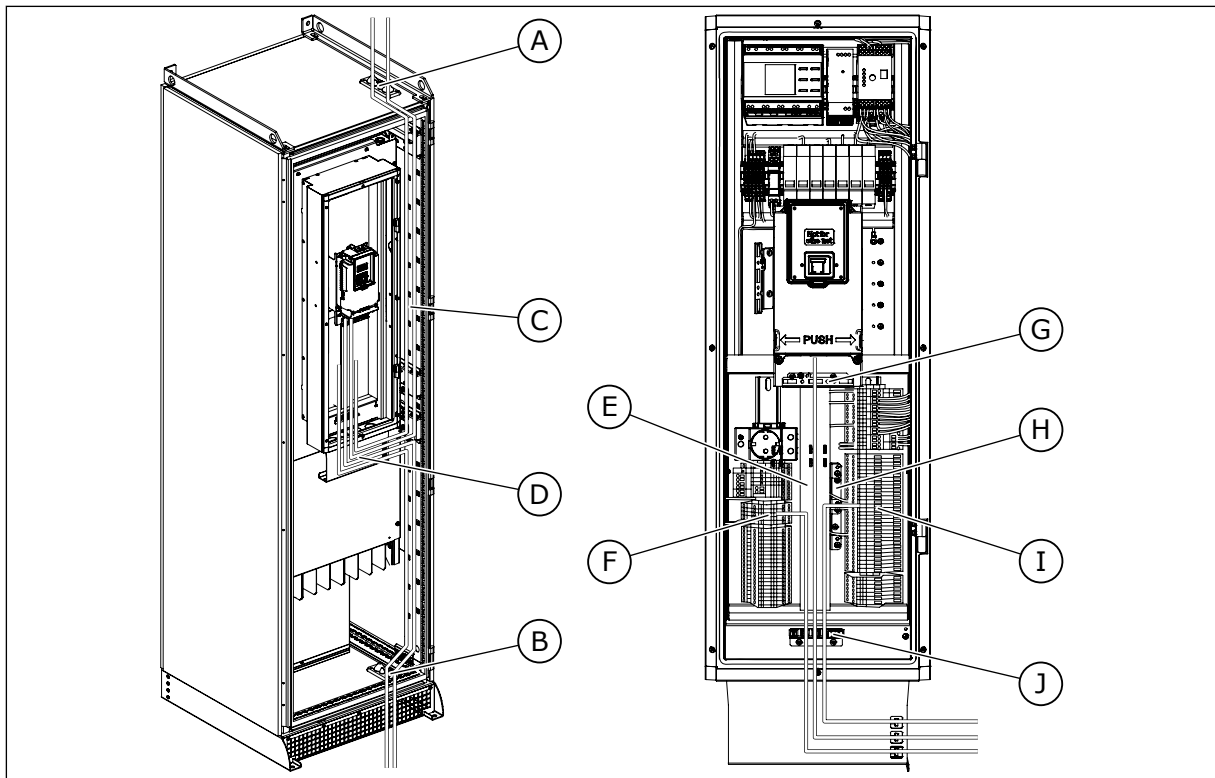

Fig. 45: Control cabling of the enclosed drive

- A. I/O cabling from top
- B. I/O cabling from bottom
- C. The cable routing plate with places for cable ties
- D. The cable carrier
- E. The cable ducts
- F. The extended I/O terminals (+CTID) to be used freely
- G. The control grounding plate
- H. The customer grounding plate
- I. The terminals for control cabling (default)
- J. Grounding clamps for cable shield

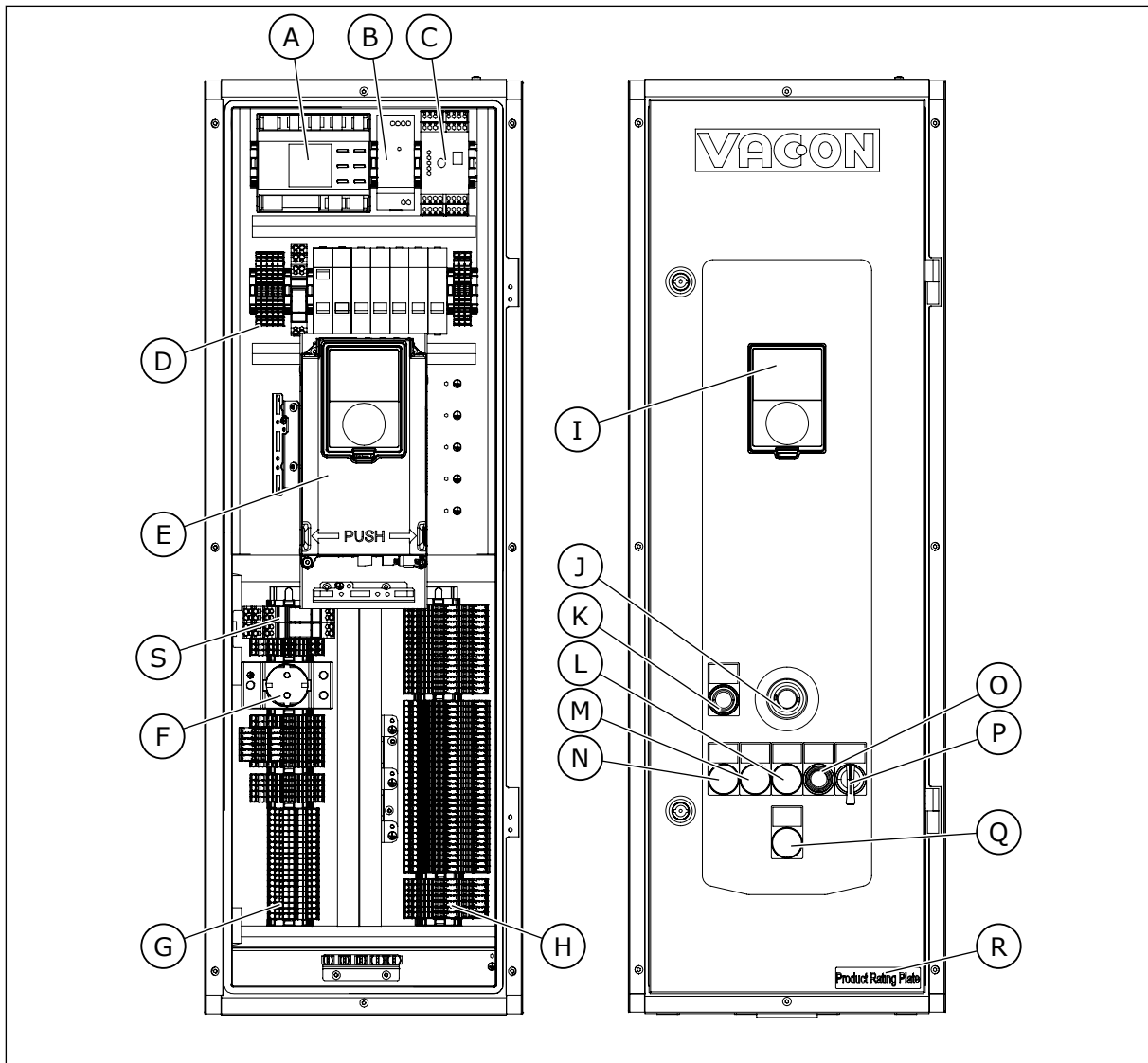

Fig. 46: The control compartment components of the cabinet

- | | |
|---|---|
| A. The insulation fault sensor (+CPIF) | L. The Fault signal light (+CDLP) |
| B. The 24 VDC power supply (+CAPD) | M. The Run signal light (+CDLP) |
| C. The emergency stop Cat 1 (+CPS1) | N. The Ready signal light (+CDLP) |
| D. The MCBs for auxiliary devices | O. The Reset button (+CDLP) |
| E. The control unit | P. The 0 - 1 - start switch (+CICO) |
| F. The 230 VAC socket (+CAPS) | Q. The insulation fault (+CPIF) |
| G. The extended I/O terminals (+CTID) to be used freely | R. The rating plate of the drive, the option codes and the serial number |
| H. The terminals for control cabling (default) | S. The auxiliary relays for additional cabinet and sine filter overtemperature monitoring circuit (+COSI and/or MR9, MR11 and MR12) |
| I. The control panel | |
| J. The emergency stop push button (+CPS0, +CPS1, +CPSB) | |
| K. The emergency stop reset button (+CPS1) | |

6.2 FIELDBUS CONNECTION

You can connect the drive to fieldbus with an RS485 or an Ethernet cable. If you use an RS485 cable, connect it to terminal A and B of the standard I/O board. If you use an Ethernet cable, connect it to the Ethernet terminal below the cover of the drive.

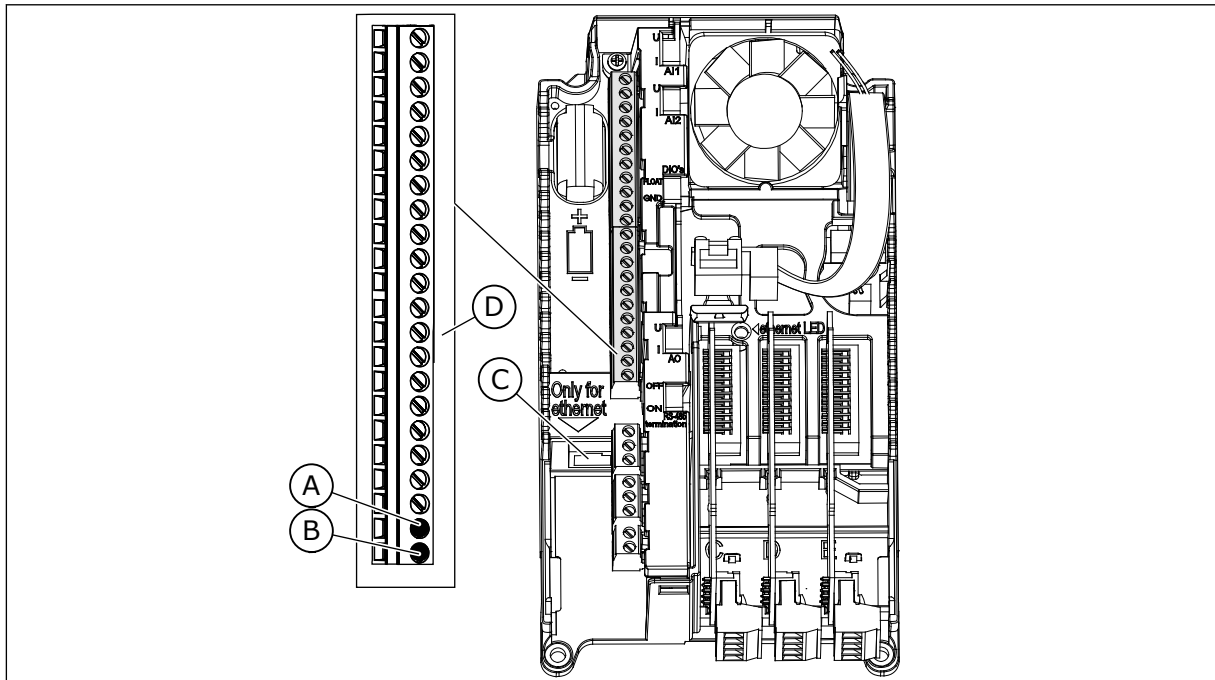

Fig. 47: The Ethernet and RS485 connections

- | | |
|------------------------------|--------------------------|
| A. RS485 terminal A = Data - | C. The Ethernet terminal |
| B. RS485 terminal B = Data + | D. The control terminals |

6.2.1 INTERNAL FIELDBUSES IN VACON® 100 PRODUCTS

The VACON® 100 product family supports internally four Ethernet fieldbuses:

- Modbus TCP/UDP
- BACnet IP
- PROFINET IO (requires +FBIE license)
- EtherNet/IP (requires +FBIE license)

Having a single Ethernet port, the Ethernet fieldbuses can be connected to networks with star topology.

The VACON® 100 family RJ45 connector does not have speed or activity LEDs. Instead it has a single LED in the middle of the AC drive. The LED cannot be seen unless the covers are removed. The LED works as listed below:

- LED is dimmed (dark) when the port is connected to a 10 Mbit/s network.
- LED is yellow when the port is connected to a 100 Mbit/s network.
- LED is dimmed (dark) when the port is connected to a 1000 Mbit/s network. The AC drive does not support a 1000 Mbit/s Ethernet, so there is no communication.

The VACON® 100 product family supports internally three RS485 fieldbuses:

- Modbus RTU
- BACnet MSTP
- Metasys N2

6.2.2 GENERAL CABLING INSTRUCTIONS FOR FIELDBUS

To keep the response time and the number of incorrect dispatches to minimum, use only standard industrial components in the network and avoid complex structures. The requirements for commercial cabling components are specified in section 8-8 in the ANSI/TIA/EIA-568-B series standards. Using commercial components can decrease system performance. The use of such products or components can cause unsatisfactory performance in industrial control applications.

6.2.2.1 General cabling instructions for Ethernet

Use only shielded cables of category CAT5e or CAT6.

Table 25: The recommended cable shielding

Recommendation order	Cable
1	Shielded and Foiled Twisted Pair (S/FTP) CAT5e or CAT6
2	Shielded Twisted Pair (STP) CAT5e or CAT6
3	Foiled Twisted Pair (FTP) CAT5e or CAT6
4	Unshielded Twisted Pair (UTP) CAT5e or CAT6

Use standard Ethernet 100 Mbit pinout connectors. The plug type to be used is a shielded RJ45 plug, maximum length 40 mm (1.57 in).

The maximum length of the CAT5e or CAT6 cable between two RJ45 ports is 100 meters. You can get cables that have a certain length, or get cable in bulk and assemble the connectors at commissioning. Obey the instructions of the manufacturer if you assemble the connectors manually. If you make the cables by yourself, be sure to select correct crimp tools and use precaution. The individual contacts of the RJ45 socket are allocated as per the T568-B standard.

In basic use, it is important that the RJ45 connectors in the cable (or the ones assembled) connect the cable shield to the ground level of the Ethernet terminal in the AC drive.

6.2.2.2 General cabling instructions for RS485

Use only shielded cables with twisted-pair signal wires.

For example, the following cables are recommended:

- Lapp Kabel UNITRONICR BUS LD FD P A, part number 2170813 or 2170814
- Belden 9841

The plug type to be used is 2.5 mm² (AWG13).

The theoretical maximum cable length depends on baud rate. See the following table for suggested maximum cable lengths.

Table 26: The RS485 cable lengths

Baud rate (kbit/s)	Length of line A (m)	Length of line B (m)
9.6	1,200	1,200
19.2	1,200	1,200
93.75	1,200	1,200
187.5	1,000	600
500	400	200
1,500	200	-
3,000–12,000	100	-

6.2.2.3 Cable routing

It is important that fieldbus cables are routed separately from motor cables. The recommended minimum distance is 300 mm. Do not let fieldbus cables and motor cables cross each other. If it is not possible, the fieldbus cables must cross other cables at an angle of 90°.

Shielded fieldbus and control cables can be routed in parallel. To have further shielding, install a grounded metal conduit around the fieldbus and control cable run.

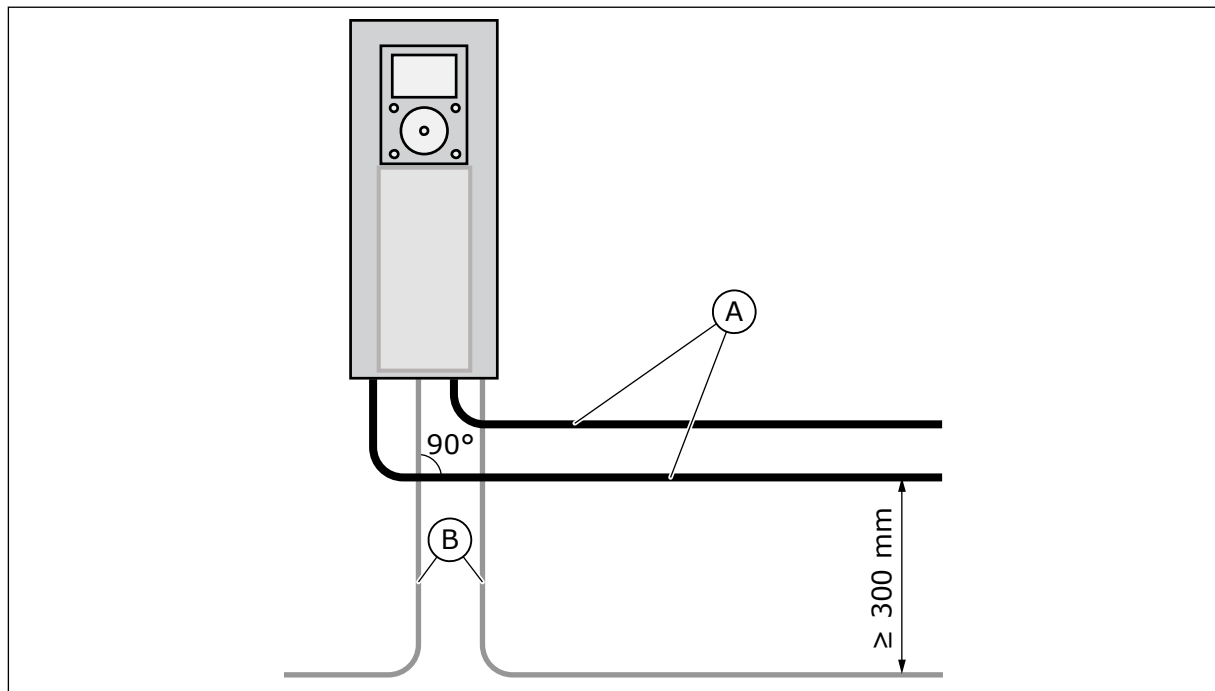

Fig. 48: Routing the motor and fieldbus cables

A. Motor cables

B. Fieldbus cables

When making an installation, use cables with right length. If you have extra cable, put it in a noise free location. Multiple rounds of cable and a large circumference area make an antenna (see Fig. 49).

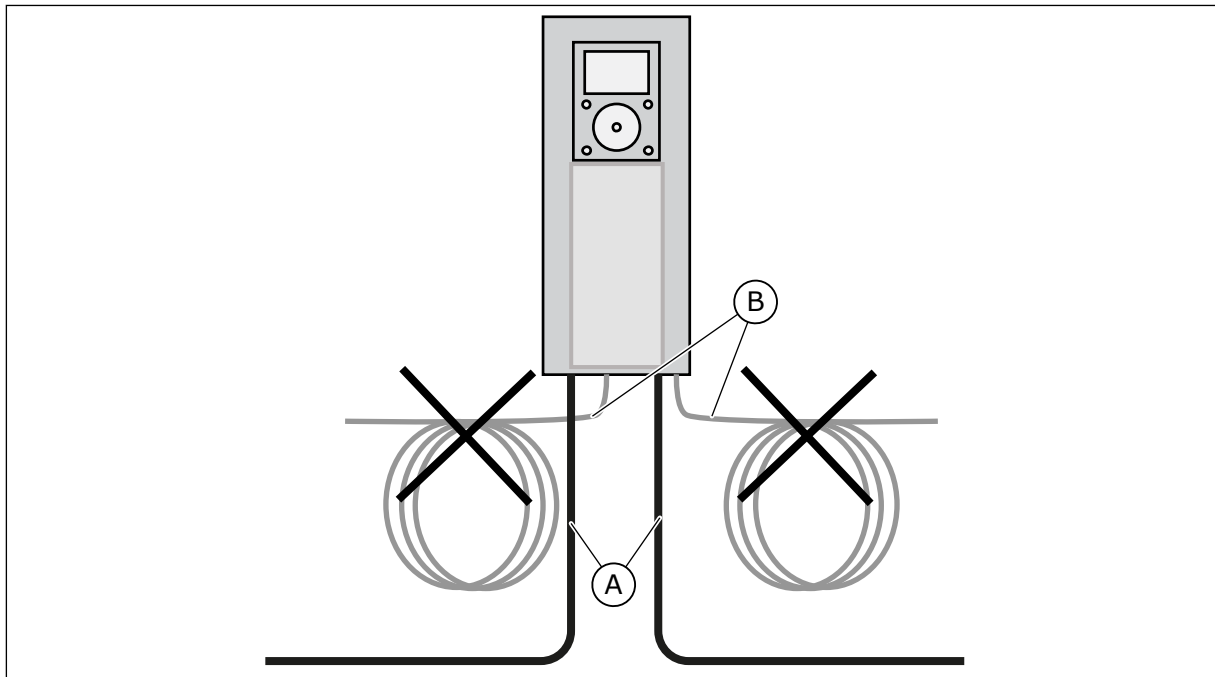

Fig. 49: An installation that makes an antenna. Noise connects to fieldbus cable and can cause communication problems.

A. Motor cables

B. Fieldbus cables

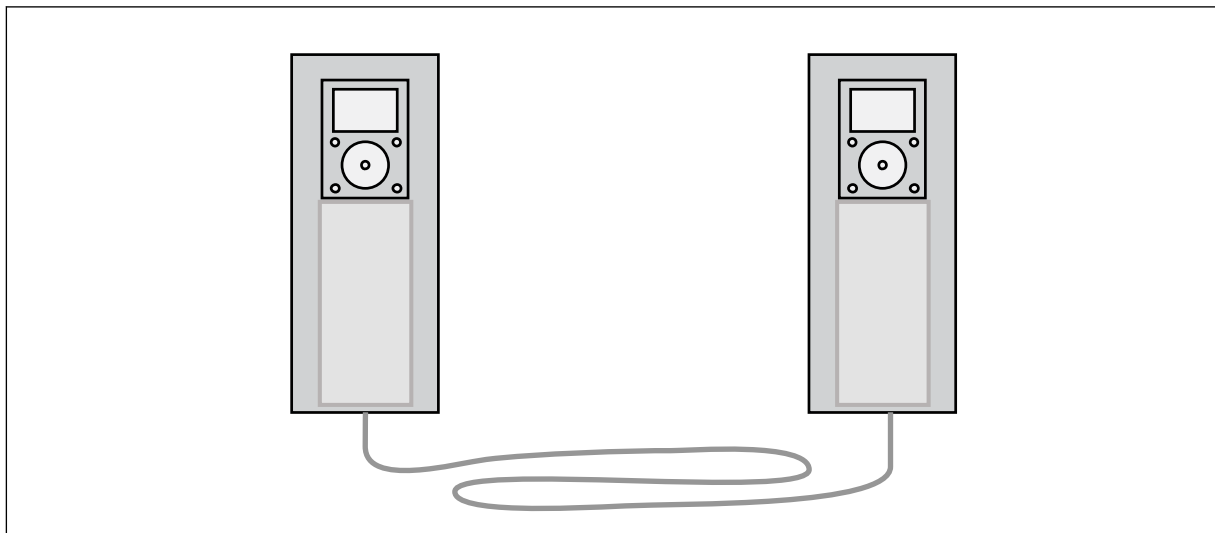

Fig. 50: An example of good routing of extra fieldbus cable. To prevent shield fracture, do not bend the cable too much or run the cable back and forth on the same path.

6.2.2.4 Strain relief

If there is a possibility of tensile load on the cable, install it with a strain relief. When it is possible, the strain relief of the fieldbus cables must not be done at the shield connection to

ground. This can make the bonding less effective. The tensile load and vibration can also cause damage to the shield.

6.2.3 ETHERNET COMMISSIONING AND CABLING

6.2.3.1 Grounding the cable shield

Equipotential bonding refers to using metal parts to make ground potential everywhere in the installation the same, the system ground. If the ground potential of all the devices is the same, you can prevent current from flowing through paths that are not designed to have current. You can also shield cables efficiently.

An error in the equipotential bonding can cause bad quality or malfunction of the fieldbus communication. It is not easy to find an error in equipotential bonding. It is also not easy to correct errors in large installations after commissioning. Thus, in the planning phase it is important to plan the installation to get good equipotential bonding. In the commissioning phase, make the equipotential bonding connections carefully.

Do grounding with low HF impedance, for example, via backplane mounting. If ground connection wires are necessary, use wires that are as short as possible. Note that paint coating acts as an insulator on metal and prevents grounding. Remove paint coating before doing grounding.

When equipotential bonding is good, the RJ45 connectors in the cable (or the ones assembled) must connect the cable shield to the ground level of the Ethernet terminal in the AC drive. The cable shield can be connected to the ground level at both ends via the built-in RC circuit (*Fig. 51*). This grounds the disturbances and, to some degree, prevents current from flowing in the cable shield. To do this, use shielded Ethernet cable (S/FTP or STP) which grounds devices via a RJ45 connector and thus uses a built-in drive RC circuit.

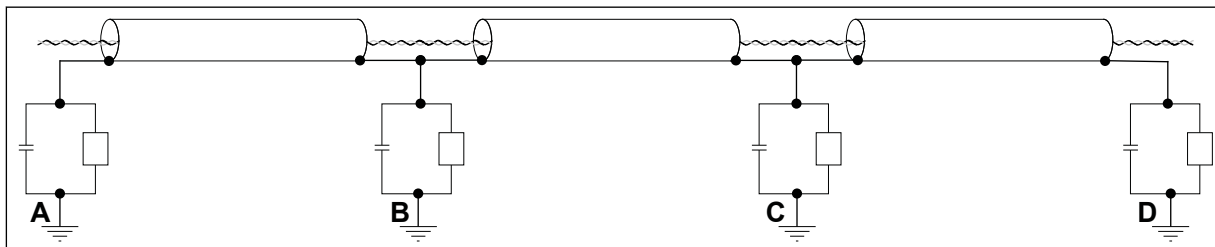

Fig. 51: Grounding via the built-in RC circuit

When disturbances are strong, the cable shield can be exposed and then 360 degrees grounded (*Fig. 54*) directly to the AC drive ground (*Fig. 52*).

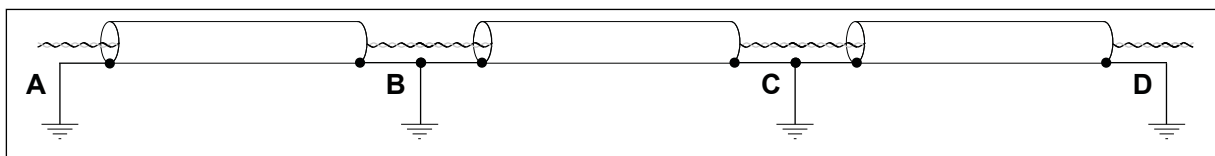

Fig. 52: Grounding in noisy environment with good equipotential. If potentials at points A, B, C and D are very different and cannot be made similar, cut the shields as in Fig. 53.

If ground potentials of the connected devices are different, cable shield that is connected at both ends causes current to flow in the shield. To prevent this, the cable shield must be

disconnected or cut at some point between the devices. Grounding should be done at a location nearest to the place where the disturbances meet the cable (Fig. 53).

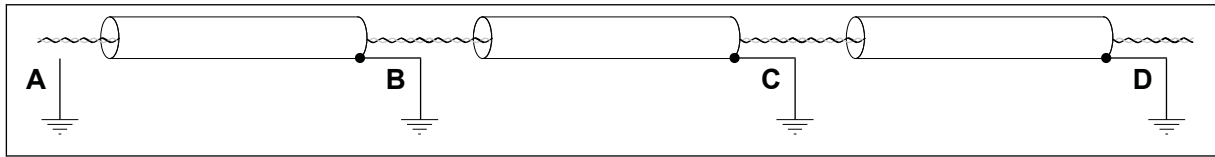

Fig. 53: Grounding in noisy environment with poor equipotential. An example of cutting the shield.

We recommend grounding the cable shield as in examples A and C (Fig. 54). Do not ground the cable shield as in example B.

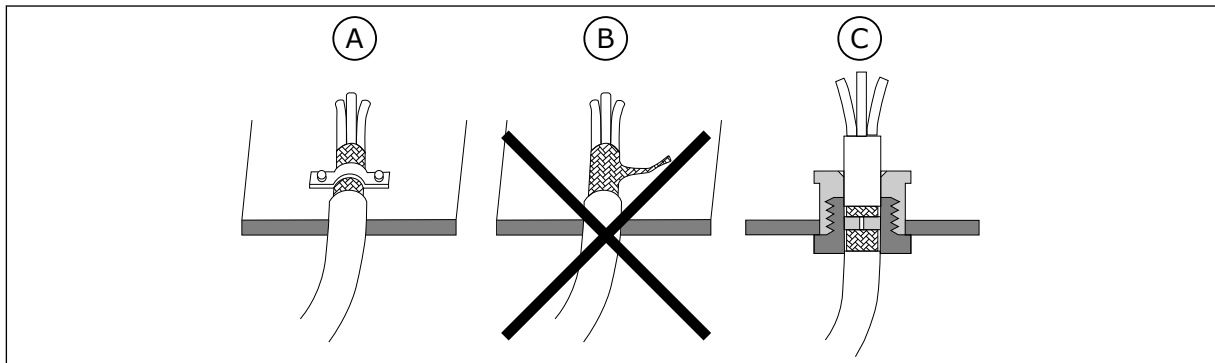

Fig. 54: Grounding the cable shield

- A. Cable clamp
- B. Ground terminal

- C. Cable gland

6.2.3.2 Using fieldbus through an Ethernet cable

ETHERNET CABLING

- 1 Connect the Ethernet cable to its terminal.

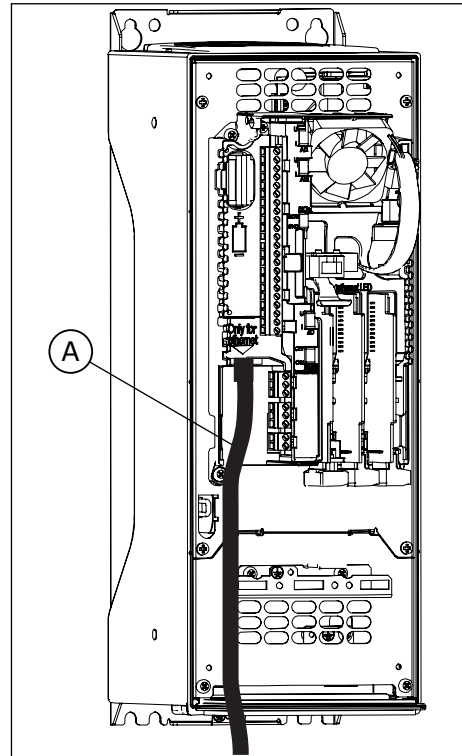

A. Ethernet cable

- 2 Put the cover of the drive back.

See more in the Installation Manual of the fieldbus that you have.

6.2.4 RS485 COMMISSIONING AND CABLING

6.2.4.1 Grounding the cable shield

Equipotential bonding refers to using metal parts to make ground potential everywhere in the installation the same, the system ground. If the ground potential of all the devices is the same, you can prevent current from flowing through paths that are not designed to have current. You can also shield cables efficiently.

An error in the equipotential bonding can cause bad quality or malfunction of the fieldbus communication. It is not easy to find an error in equipotential bonding. It is also not easy to correct errors in large installations after commissioning. Thus, in the planning phase it is important to plan the installation to get good equipotential bonding. In the commissioning phase, make the equipotential bonding connections carefully.

Do grounding with low HF impedance, for example, via backplane mounting. If ground connection wires are necessary, use wires that are as short as possible. Note that paint coating acts as an insulator on metal and prevents grounding. Remove paint coating before doing grounding.

This chapter describes the principles of cable shield grounding. Notice that the internal RS485 fieldbus in VACON 100® products does not have jumpers for grounding options.

Connect the cable shield directly to the frame of the AC drive (Fig. 55 and Fig. 57).

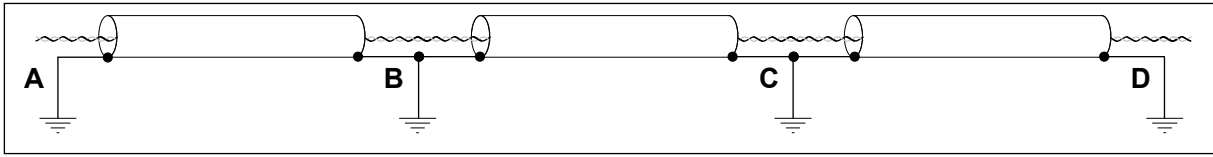

Fig. 55: Grounding in noisy environment with good equipotential. If potentials at points A, B, C and D are very different and cannot be made similar, cut the shields as in Fig. 56.

If ground potentials of the connected devices are different, cable shield that is connected at both ends causes current to flow in the shield. To prevent this, the cable shield must be disconnected or cut at some point between the devices (Fig. 56).

When disturbances are strong, the cable shield can be exposed and then 360 degrees grounded directly to the AC drive ground (Fig. 57). When the connection is made as in Fig. 56, grounding should be done at a location nearest to the place where the disturbances meet the cable.

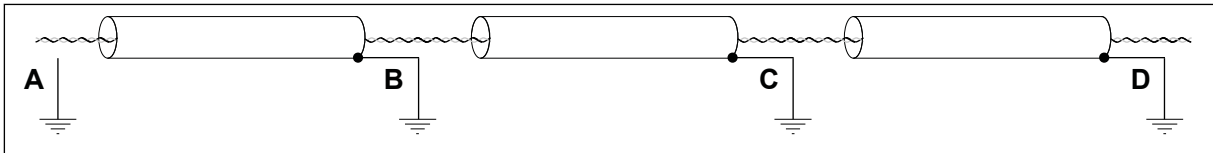

Fig. 56: Grounding in noisy environment with poor equipotential. An example of cutting the shield.

We recommend grounding the cable shield as in examples A and C (Fig. 57). Do not ground the cable shield as in example B.

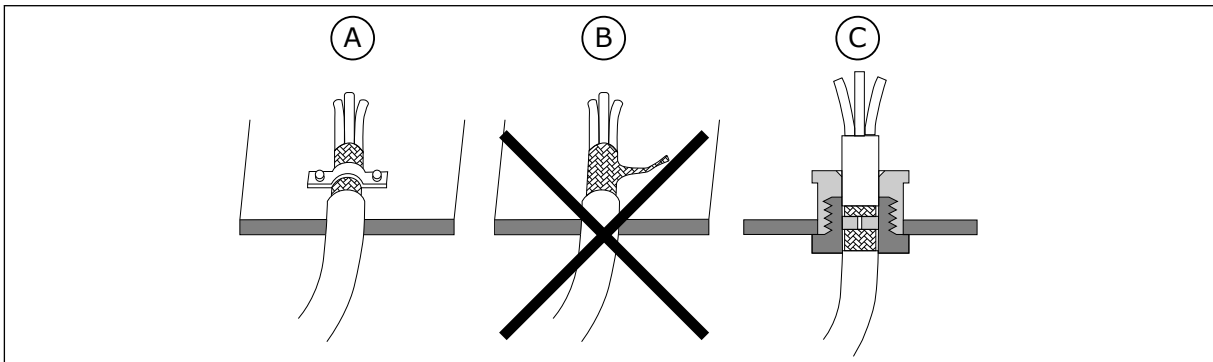

Fig. 57: Grounding the cable shield

- A. Cable clamp
B. Ground terminal

- C. Cable gland

6.2.4.2 The RS485 bus biasing

When no device on the RS485 bus line transmits data, all devices are in an idle state. In such condition the bus voltage is in an indefinite state, usually near 0 V, because of the termination resistors. This can cause problems in character reception because the RS485 standard considers the voltage interval from -200 mV to +200 mV as an undefined state. Thus, bus biasing is needed to keep the voltage in state '1' (above +200 mV) also between the messages.

Unless the first and last device in the RS485 bus line have a built-in bus biasing function, you must add a separate active termination resistor specially designed for the RS485 bus (e.g. Siemens active RS485 terminating element 6ES7972-0DA00-0AA0).

6.2.4.3 Using fieldbus through an RS485 cable

RS485 CABLING

- 1 Remove approximately 15 mm (0.59 in) of the grey shield of the RS485 cable. Do this for the 2 fieldbus cables.
 - a) Strip the cables for approximately 5 mm (0.20 in) to put them in the terminals. Do not keep more than 10 mm (0.39 in) of the cable outside the terminals.
 - b) Strip the cable at such a distance from the terminal that you can attach it to the frame with the grounding clamp for control cable. Strip the cable at a maximum length of 15 mm (0.59 in). Do not remove the aluminium shield of the cable.

- 2 Connect the cable to the default I/O board of the drive, in terminals A and B.
 - A = negative
 - B = positive

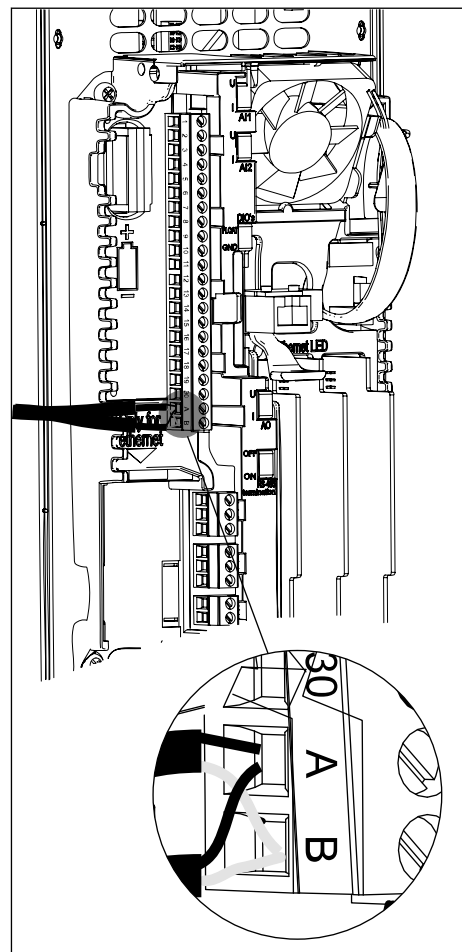
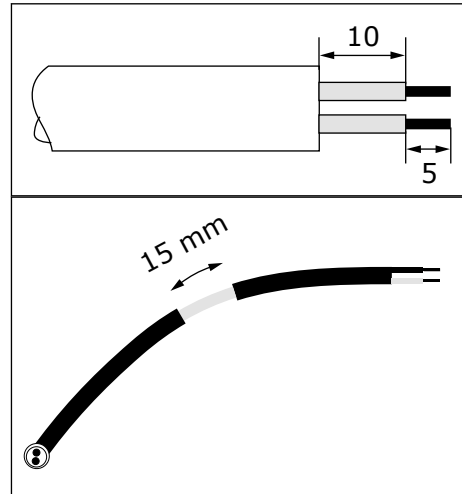

- 3 Attach the shield of the cable to the frame of the drive with a grounding clamp for control cable to make a grounding connection.

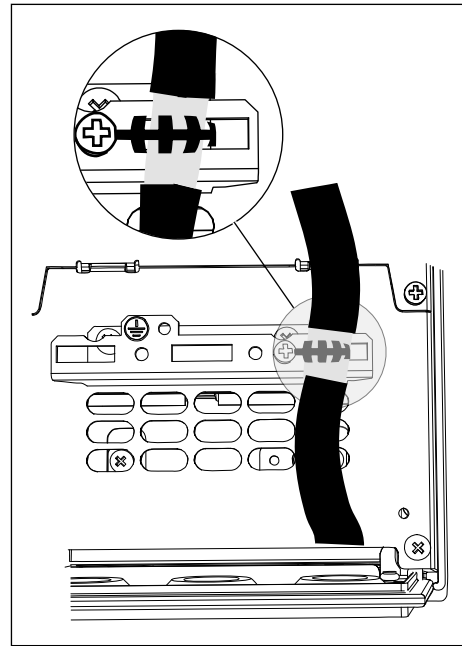

- 4 If the drive is the last device on the fieldbus line, set the bus termination. Set the bus termination for the first and the last device of the fieldbus line. We recommend that the first device on the fieldbus is the master device.

- a) Find the DIP switches on the left side of the control unit of the drive.
- b) Set the DIP switch of the RS485 bus termination to the ON position.

**NOTE!**

The termination resistors are placed at both ends of the fieldbus line to decrease signal reflections on the line. Biasing is built in the bus termination resistor. The termination resistance is 220 Ω.

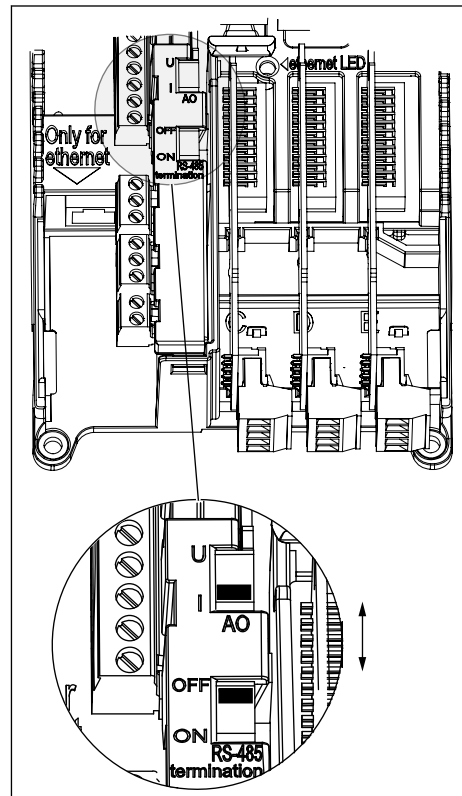

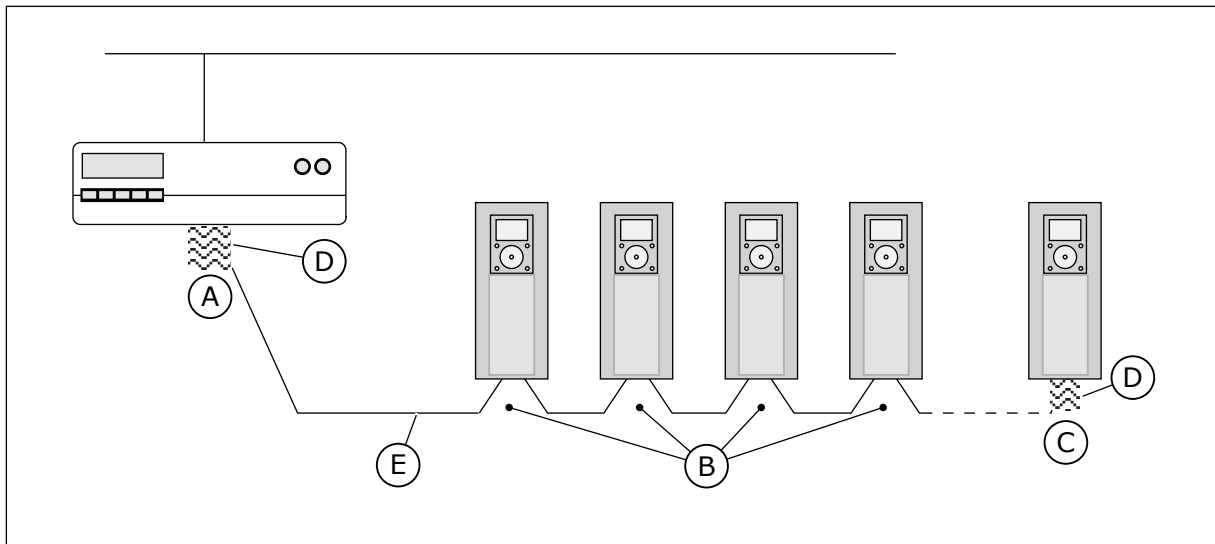

- | | |
|---|--|
| A. The termination is activated | D. The bus termination. The resistance is 220 Ω. |
| B. The termination is deactivated | E. The fieldbus |
| C. The termination is activated with a DIP switch | |

**NOTE!**

If the last device on the fieldbus line is powered down, the termination resistance is lost. The loss of termination resistance causes signal reflections on the line, which can disrupt the fieldbus communication. Do not power down the last device on the fieldbus line while the fieldbus is active.

6.3 INSTALLATION OF OPTION BOARDS

**CAUTION!**

Do not install, remove, or replace option boards on the drive when the power is on. Doing this can cause damage to the boards.

Install the option boards into the option board slots of the drive. Refer to *Table 27*.

Table 27: The option boards and their correct option board slots

Type of the option board	Description of the option board	The correct slot or slots
OPTB1	The I/O expander board	C, D, E
OPTB2	The Thermistor relay board	C, D, E
OPTB4	The I/O expander board	C, D, E
OPTB5	The Relay board	C, D, E
OPTB9	The I/O expander board	C, D, E
OPTBF	The I/O expander board	C, D, E
OPTBH	The Temperature measurement board	C, D, E
OPTBJ	The Safe Torque Off board	E
OPTC4	The LonWorks fieldbus board	D, E
OPTE2	The RS485 (Modbus/N2) fieldbus board	D, E
OPTE3	The Profibus DPV1 fieldbus board	D, E
OPTE5	The Profibus DPV1 fieldbus board (with a type D connector)	D, E
OPTE6	The CanOpen fieldbus board	D, E
OPTE7	The DeviceNet fieldbus board	D, E
OPTE8	The RS485 (Modbus/N2) fieldbus board (with a type D connector)	D, E
OPTE9	The Dual-port ethernet fieldbus board	D, E
OPTEA	The Advanced dual-port ethernet fieldbus board	D, E
OPTEC	The EtherCAT fieldbus board	D, E

THE INSTALLATION PROCEDURE

- 1 Open the door of the control compartment.



WARNING!

Do not touch the control terminals. They can have a dangerous voltage also when the drive is disconnected from mains.

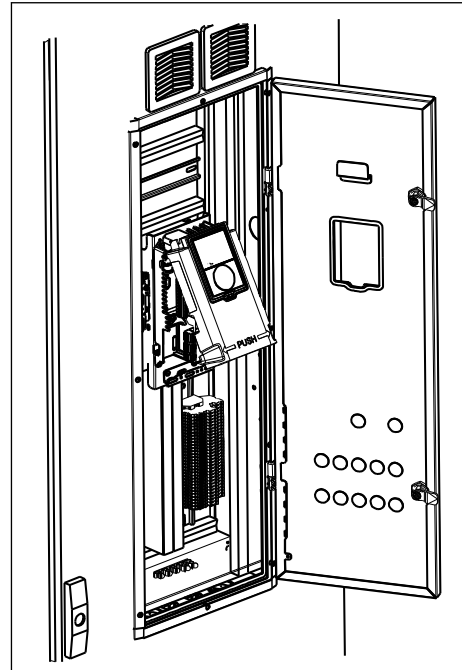

- 2 If you have an OPTB or an OPTC option board, make sure that the label on it says "dv" (dual voltage). This shows that the option board is compatible with the drive.



NOTE!

It is not possible to install option boards that are not compatible with the drive.

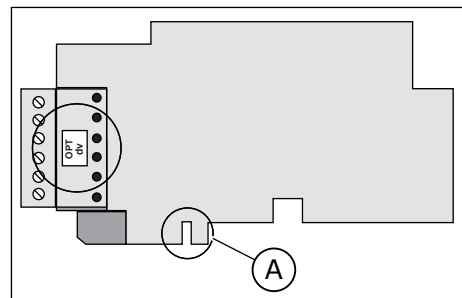

A. The slot coding

- 3 To get access to the option board slots, open the cover of the control unit.

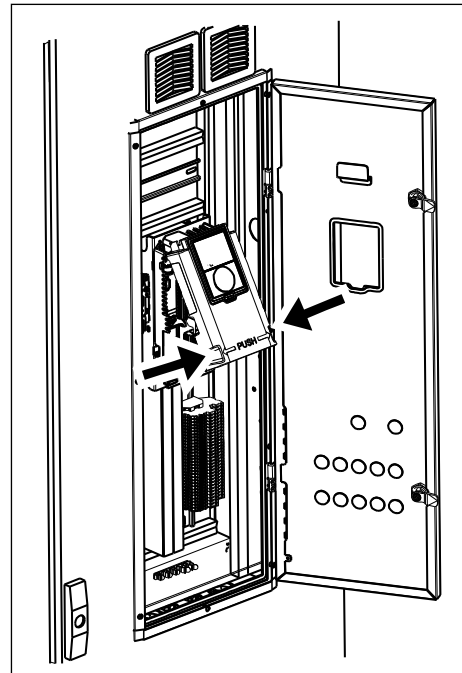

- 4 Install the option board into the correct slot: C, D or E. See *Table 27*.
- a) The option board has a slot coding, because of which it is not possible to install the option board in an incorrect slot.

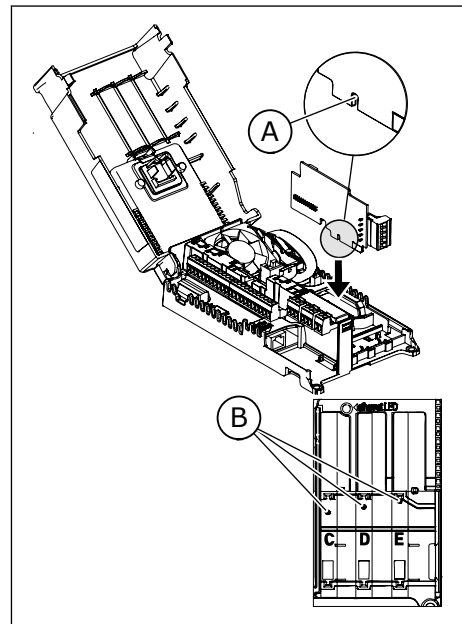

- A. The slot coding
B. The option board slots

- 5 Close the cover of the control unit. Close the door of the control compartment.

6.4 INSTALLATION OF A BATTERY FOR THE REAL TIME CLOCK (RTC)

To use the Real Time Clock (RTC), you must install a battery in the drive.

- 1 Use a ½ AA battery with 3.6 V and a capacity of 1000-1200 mAh. You can use, for example, a Vitzrocell SB-AA02.
- 2 Install the battery on the left side of the control panel. See .

The battery will last approximately 10 years. See more about the functions of the RTC in the Application Manual.

7 COMMISSIONING AND ADDITIONAL INSTRUCTIONS

7.1 COMMISSIONING SAFETY

Before you start the commissioning, read these warnings.

**WARNING!**

Do not touch the internal components or the circuit boards of the drive when the drive is connected to mains. These components are live. A contact with this voltage is very dangerous. The galvanically isolated control terminals are not live.

**WARNING!**

Do not touch the motor cable terminals U, V, W, the brake resistor terminals or the DC terminals when the drive is connected to mains. These terminals are live when the drive is connected to mains, also when the motor does not operate.

**WARNING!**

Do not make connections to or from the AC drive when it is connected to mains. There is a dangerous voltage.

**WARNING!**

To do work on the connections of the drive, disconnect the drive from mains. Wait 5 minutes before you open the cabinet door or the cover of the drive. Then use a measuring device to make sure that there is no voltage. The connections of the drive are live 5 minutes after it is disconnected from mains.

**WARNING!**

Before you do electrical work, make sure that there is no voltage.

**WARNING!**

Do not touch the control terminals. They can have a dangerous voltage also when the drive is disconnected from mains.

**WARNING!**

Before you connect the drive to mains, make sure that the front cover and the cable cover of the drive are closed. The connections of the AC drive are live when the drive is connected to mains.

7.2 OPERATION OF THE MOTOR

7.2.1 CHECKS BEFORE STARTING THE MOTOR

Before you start the motor, do these checks.

- Make sure that all the START and STOP switches that are connected to the control terminals are in the STOP position.
- Make sure that you can start the motor safely.
- Activate the Start-up wizard. See the Application Manual for the AC drive that you have.
- Set the maximum frequency reference (that is, the maximum speed of the motor), so that it agrees with the motor and the device that is connected to the motor.

7.3 MEASURING THE CABLE AND MOTOR INSULATION

Do these checks if necessary.

The insulation checks of the motor cable

1. Disconnect the motor cable from the terminals U, V, and W and from the motor.
2. Measure the insulation resistance of the motor cable between phase conductors 1 and 2, between phase conductors 1 and 3, and between phase conductors 2 and 3.
3. Measure the insulation resistance between each phase conductor and the grounding conductor.
4. The insulation resistance must be $>1 \text{ M}\Omega$ at the ambient temperature of $20 \text{ }^\circ\text{C}$ ($68 \text{ }^\circ\text{F}$).

The insulation checks of the mains cable

1. Disconnect the mains cable from the terminals L1, L2, and L3 and from mains.
2. Measure the insulation resistance of the mains cable between phase conductors 1 and 2, between phase conductors 1 and 3, and between phase conductors 2 and 3.
3. Measure the insulation resistance between each phase conductor and the grounding conductor.
4. The insulation resistance must be $>1 \text{ M}\Omega$ at the ambient temperature of $20 \text{ }^\circ\text{C}$ ($68 \text{ }^\circ\text{F}$).

The insulation checks of the motor

1. Disconnect the motor cable from the motor.
2. Open the bridging connections in the motor connection box.
3. Measure the insulation resistance of each motor winding. The voltage must be the same or higher than the motor nominal voltage, but not higher than 1000 V.
4. The insulation resistance must be $>1 \text{ M}\Omega$ at the ambient temperature of $20 \text{ }^\circ\text{C}$ ($68 \text{ }^\circ\text{F}$).
5. Obey the instructions of the motor manufacturer.

7.4 INSTALLATION IN A MARINE ENVIRONMENT

When you install the AC drive in a marine environment, use the marine construction option (+EMAR). See the Marine Installation Guide.

7.5 INSTALLATION IN A CORNER-GROUNDED NETWORK

You can use corner grounding with the drive sizes MR8-MR12 with a 208-240 V mains and with a 380-480 V mains. In these conditions, you must change the EMC protection level to C4. See the instructions in chapter 7.6 *Installation in an IT system*.

7.6 INSTALLATION IN AN IT SYSTEM

If your mains is impedance-grounded (IT), the AC drive must have the EMC protection level C4. If your drive has the EMC protection level C3, it is necessary to change it to C4. To do this, remove the EMC jumper.



WARNING!

Do not make changes in the AC drive when it is connected to mains. The components of the drive are live when the drive is connected to mains.



CAUTION!

Before you connect the AC drive to mains, make sure that the EMC level of the drive is correct. An incorrect EMC level can cause damage to the drive.

7.6.1 THE EMC JUMPER IN MR8

Change the EMC protection of the AC drive from level C3 to level C4.

- 1 Open the cover of the AC drive.
- 2 Find the EMC box. To get access to the EMC jumper, remove the cover of the EMC box.

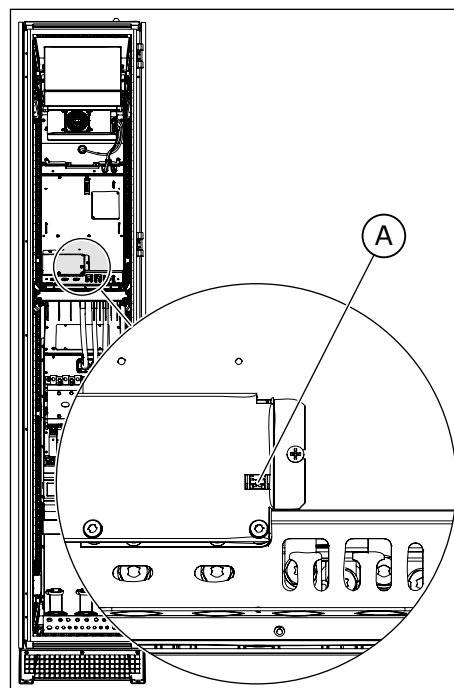

A. The EMC jumper

- 3 Remove the EMC jumper. Attach the cover of the EMC box again.

- 4 Find the grounding arm and push it down.

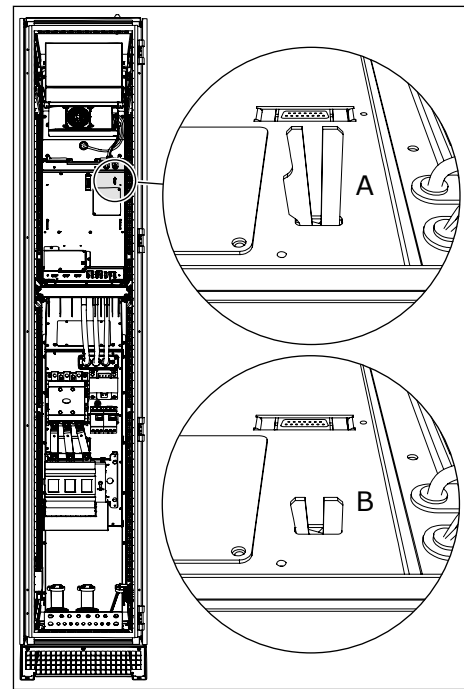

- A. The grounding arm is up (level C3)
 B. The grounding arm is down (level C4)

- 5 After the change, write "The EMC level was changed" and the date on the "product changed" label. If the label is not attached at this time, attach it on the drive near the name plate.

Product modified	
.....	Date:
.....	Date:
.....	Date:

7.6.2 THE EMC JUMPER IN MR9 AND MR11

Change the EMC protection of the AC drive from level C3 to level C4.

THE EMC JUMPER 1

- 1 Open the covers of the AC drive.

- 2 Loosen the screws of the cover plate and remove it.

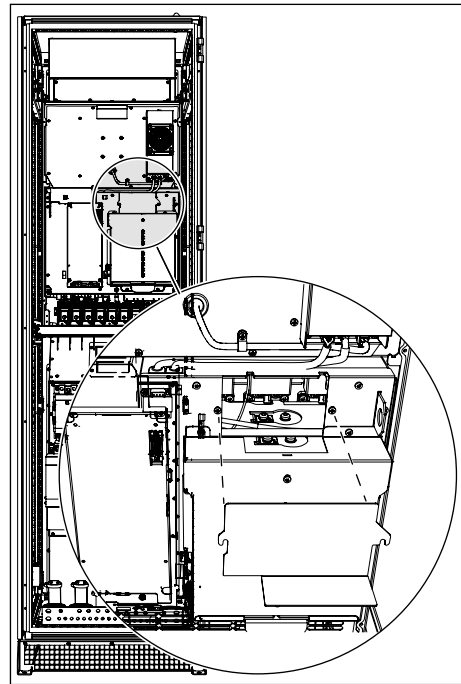

- 3 Remove the EMC jumper.

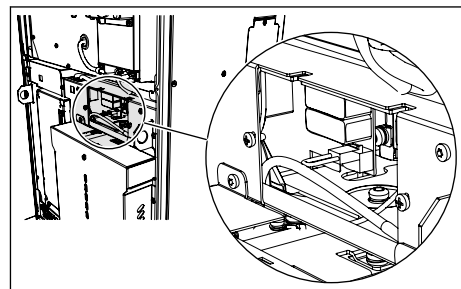

- 4 If you change the EMC level, write "The EMC level was changed" and the date on the "product changed" label. If the label is not attached at this time, attach it on the drive near the name plate.

Product modified	
	Date:
	Date:
	Date:

THE EMC JUMPER 1, MR9B AND MR11

- 1 Open the cover of the AC drive.

- 2 Remove the EMC jumper.

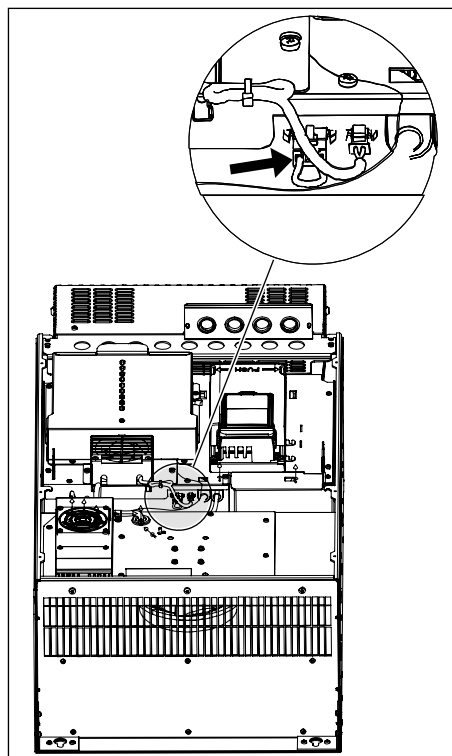

The EMC jumper

THE EMC JUMPERS 2 AND 3

- 1 Remove the cover of the extension box, the touch shield, and the I/O plate with the I/O grommet plate.

- 2 Find the 2 EMC jumpers on the EMC board. They are not adjacent to each other. Remove the EMC jumpers.

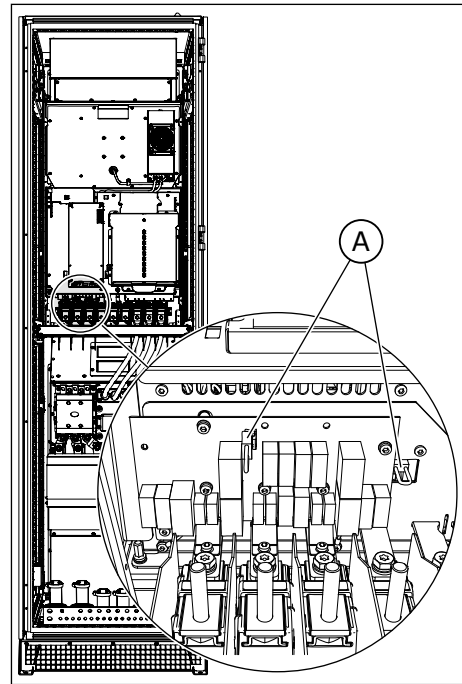

A. The EMC jumpers

THE EMC CAPACITORS (WITH BRAKE CHOPPER OPTION)

- 1 Disconnect three capacitors by removing three screws and bending the capacitor legs aside.

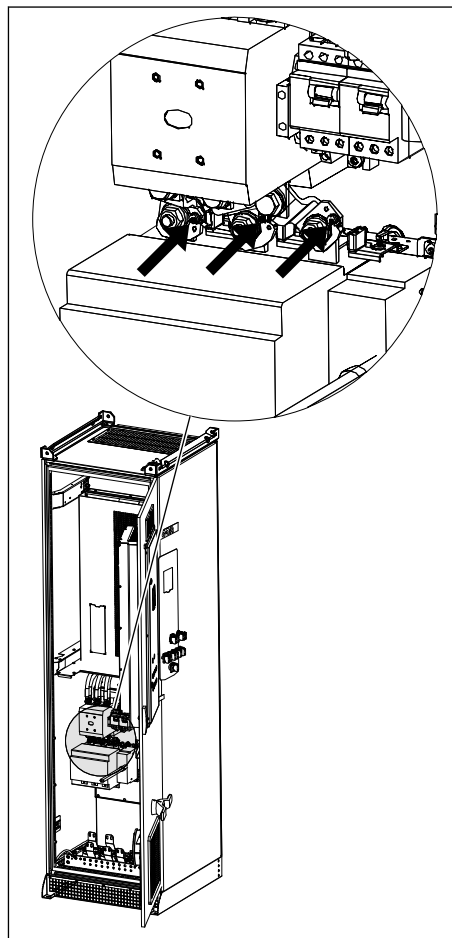

Fig. 58: Contactor and OS

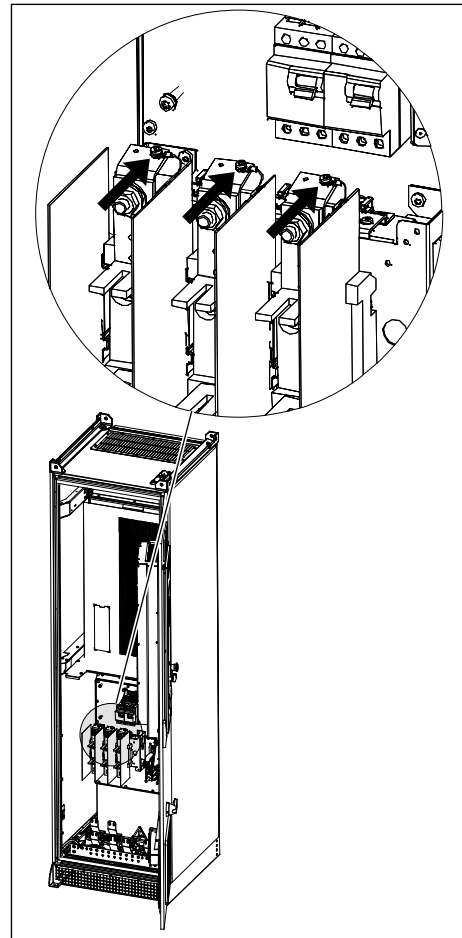

Fig. 58: OFAX or OS

THE PRODUCT MODIFIED LABEL

- 1 If you change the EMC level, write "The EMC level was changed" and the date on the "product changed" label. If the label is not attached at this time, attach it on the drive near the name plate.

Product modified	
.....	Date:
.....	Date:
.....	Date:

7.6.3 THE EMC JUMPER IN MR10 AND MR12

Change the EMC protection of the AC drive from level C3 to level C4.

FINDING THE EMC JUMPER

- 1 Remove the covers of the AC drive.
 - In MR12, do these steps for each power unit. Also remove the fuse switch linkage.

- 2 Find the EMC jumper between the terminals L2 and L3.

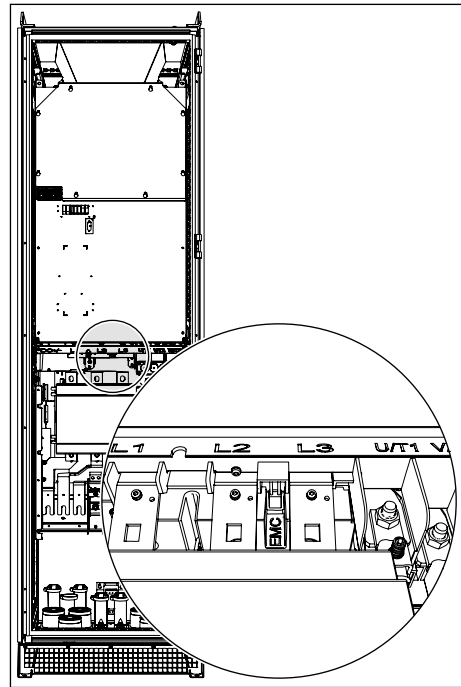

- 3 Remove the EMC jumper.

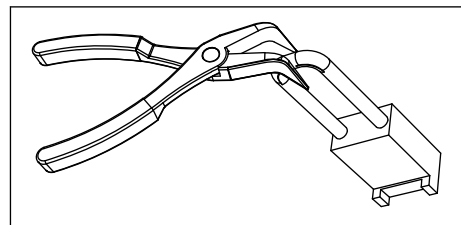

- 4 If you change the EMC level, write "The EMC level was changed" and the date on the "product modified" label. If the label is not attached at this time, attach it on the drive near the name plate.

Product modified	
.....	Date:
.....	Date:
.....	Date:

7.7 MAINTENANCE

7.7.1 MAINTENANCE INTERVALS

To make sure that the drive operates correctly and has a long life, we recommend that you do regular maintenance. Refer to *Table 28*.

It is not necessary to replace the main capacitors of the drive, because they are a thin film type capacitors.



WARNING!

Do not make changes in the AC drive when it is connected to mains. The components of the drive are live when the drive is connected to mains.

Table 28: The maintenance intervals and tasks

Maintenance interval	Maintenance task
Regularly	Do a check of the tightening torques of the terminals. Do a check of the filters.
6-24 months (The interval is different in different environments.)	Do a check of the mains and motor cable terminals and the control terminals. Make sure that the cooling fan operates correctly. Make sure that there is no corrosion on the terminals, the busbars or other surfaces. Do a check of the door filters of the cabinet. Do a check of the internal filter of the power unit.
24 months (The interval is different in different environments.)	Clean the heatsink and the cooling tunnel.
6-10 years	Replace the main fan. Replace the internal fans if the drive has them. Replace the fan power supply.
10 years	Replace the battery of the RTC. The battery is optional.

This table is valid for VACON® components. To do maintenance on components that are made by other manufacturers, obey the manual of the component in question.

7.7.2 REPLACING THE AIR FILTERS OF THE AC DRIVE

Clean or replace the filters of the cabinet regularly.

REPLACING THE FILTER ON THE CABINET DOOR

- 1 To remove the cover of the filter, pull it out and up.

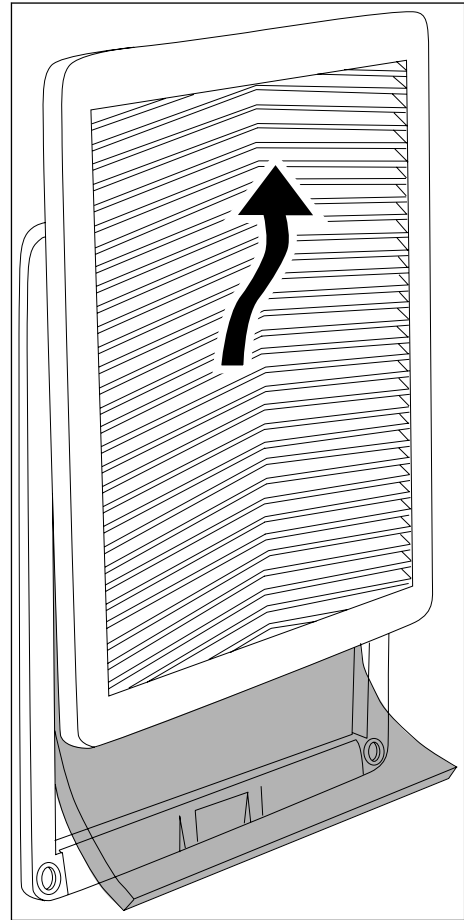

- 2 Clean or replace the filter.
- 3 Put the cover of the filter back.

7.7.3 REPLACING THE FANS OF THE AC DRIVE

7.7.3.1 Replacing the fans in MR8

Here are the instructions on how to replace the fans of the drive.

REPLACING THE FAN POWER SUPPLY, MR8

- 1 Remove the cover of the AC drive.

- 2 Disconnect the cables from the fan power supply.
 - a) Disconnect the fan supply cable from connector X81.
 - b) Disconnect the fan driver cable from connector X61.
 - c) Disconnect the DC supply cable from connector X8.

Remove the 4 screws that hold the fan power supply.

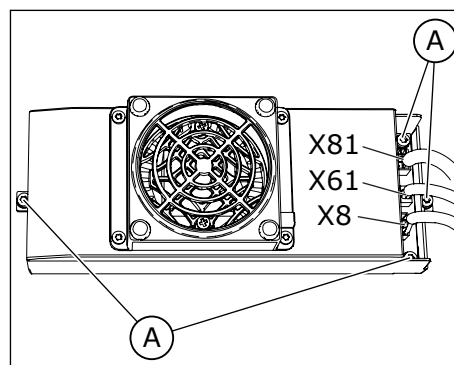

A. The 4 screws

- 3 Lift off the fan power supply.
- 4 Replace the fan power supply. Attach it with the screws.
- 5 Connect the cables and put the cover of the drive back.

REPLACING THE MAIN FAN, MR8

- 1 Remove the cover of the AC drive.
- 2 Remove the fan power supply. See the previous instructions.
- 3 Remove the 4 screws that hold the main fan unit. Lift off the main fan unit.

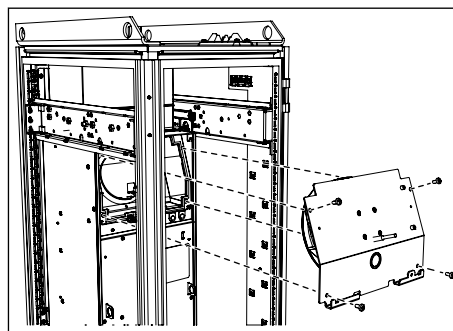

- 4 To release the fan from the cover plate, remove the 4 screws.

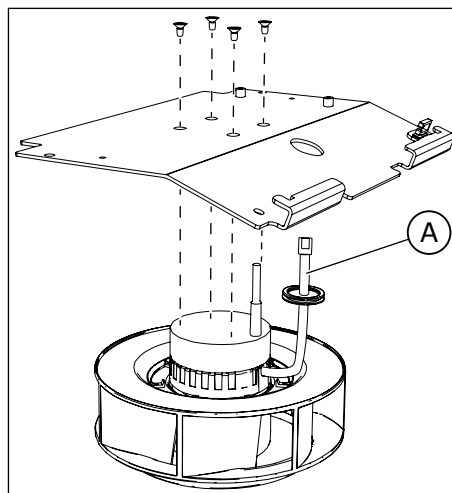

A. The fan cable

- 5 Release the grommet on the fan cable from the cover plate and pull out the cable.
- 6 Replace the main fan. Attach the screws.
- 7 Re-assemble the drive and connect the cables.

7.7.3.2 Replacing the fans in MR9 and MR11

Here are the instructions on how to replace the fans of the drive.

REPLACING THE FAN POWER SUPPLY, MR9 AND MR11

- 1 Remove the cover of the AC drive.
- 2 Disconnect the cables from the fan power supply.
 - a) Disconnect the fan supply cable from connector X81.
 - b) Disconnect the fan driver cable from connector X61.
 - c) Disconnect the DC supply cable from connector X8.

Remove the 4 screws that hold the fan power supply.

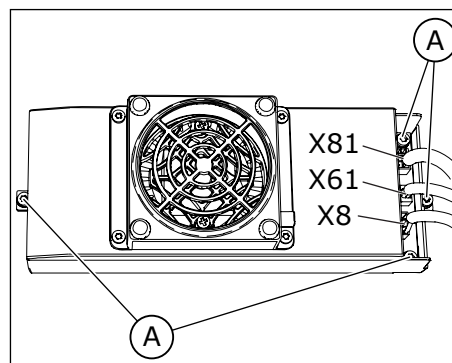

A. The 4 screws

- 3 Lift off the fan power supply.
- 4 Replace the fan power supply. Attach it with the screws.
- 5 Connect the cables and put the cover of the drive back.

REPLACING THE MAIN FAN, MR9 AND MR11

- 1 Remove the cover of the AC drive.

- 2 Disconnect the cables from the fan power supply.
- 3 Remove the 12 screws from the fan cover plate.
Use the handle to lift off the main fan unit.

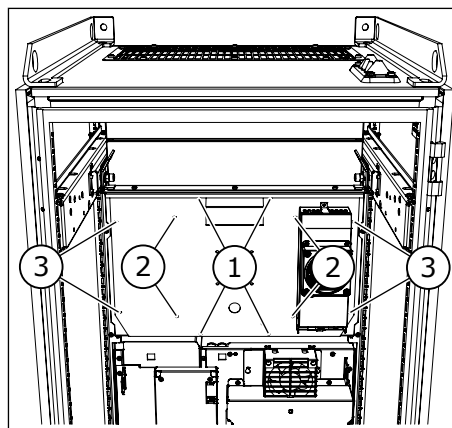

- 4 To release the fan from the cover plate, remove the 4 screws.

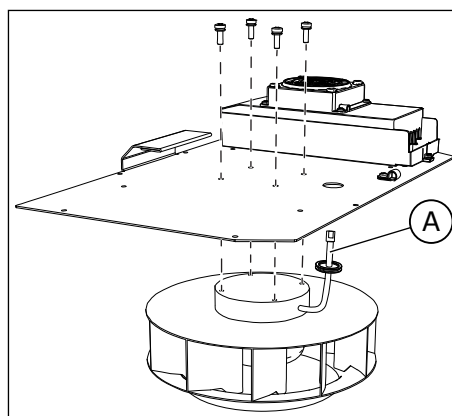

A. The fan cable

- 5 Release the grommet on the fan cable from the cover plate and pull out the cable.
- 6 Replace the main fan.
 - a) When you re-attach the main fan unit, make sure that the sealing tape under the fan plate is in good condition.
 - b) Attach the screws in the tightening order that is marked in the figure of the main fan unit (1 > 2 > 3).
- 7 Re-assemble the drive and connect the cables.

REPLACING THE DOOR FANS, MR9B AND MR11

- 1 Disconnect the cables from the fan.
- 2 To release the fan from the door plate, remove the two screws.
- 3 Replace the fan.

- 4 Install the new fan with two screws.

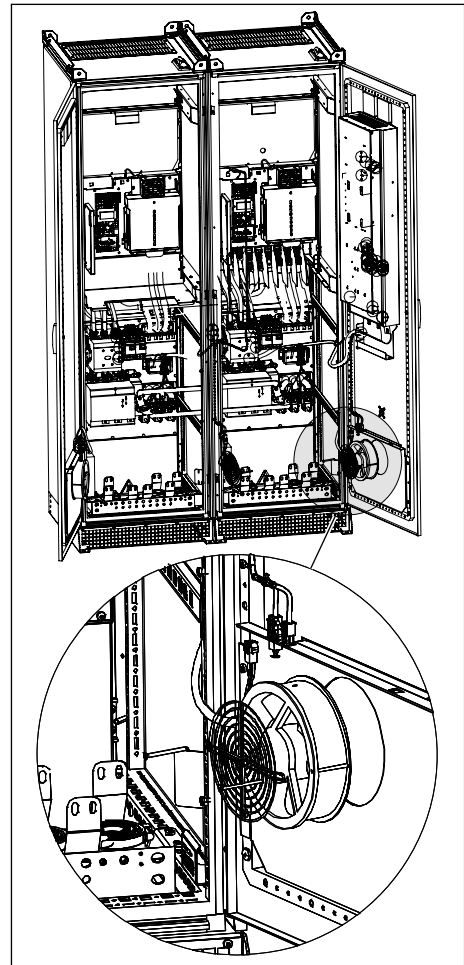

- 5 Connect the cables.

7.7.3.3 Replacing the fans in MR10 and MR12

Here are the instructions on how to replace the fans of the drive.

REPLACING THE MAIN FAN ASSEMBLY, MR10 AND MR12

- 1 Loosen the 8 screws and lift off the service lid.

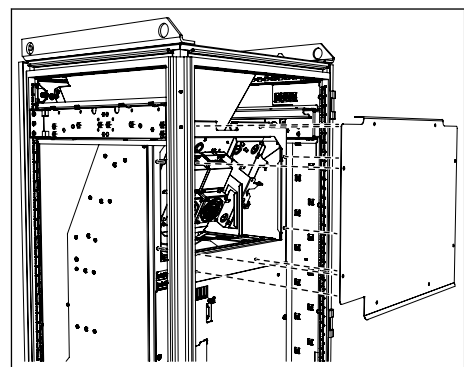

- 2 Disconnect the cables from each fan power supply.
 - a) Disconnect the fan driver cable from connector X61.
 - b) Disconnect the DC supply cable from connector X8.

Remove the 5 screws.

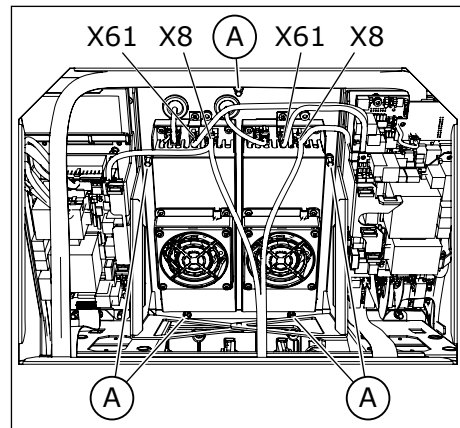

A. The 5 screws

- 3 Pull out the whole fan assembly. The assembly weighs approximately 11 kg.

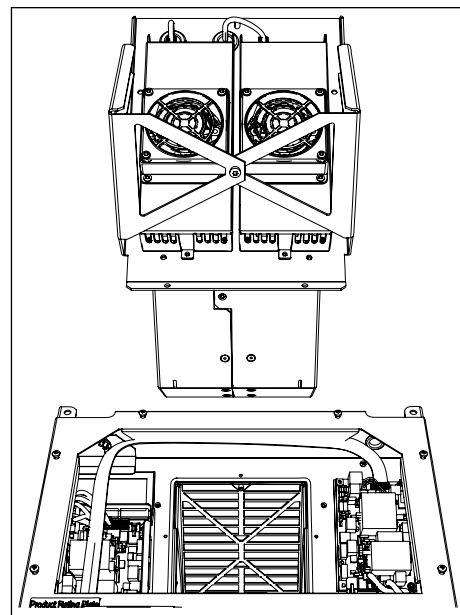

- 4 Replace the main fan assembly. Attach it with the screws.
- 5 Connect the cables and attach the service lid.

REPLACING THE FAN POWER SUPPLIES, MR10 AND MR12

You can replace only 1 or both the fan power supplies.

- 1 Remove the main fan assembly. See the previous instructions.

- 2
 - a) Disconnect the fan supply cable from connector X81.
 - b) Disconnect the fan driver cable from connector X61.
 - c) Disconnect the DC supply cable from connector X8.

Remove the 4 screws from each supply.

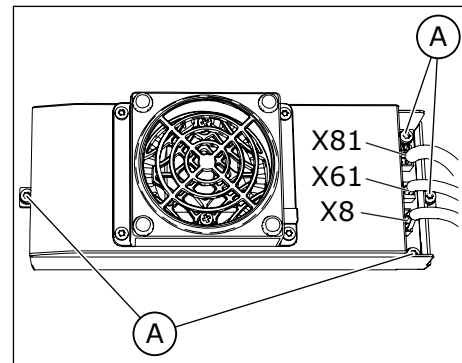

A. The 4 screws

- 3 Replace the fan power supplies.
- 4 Attach the screws, connect the cables, and re-assemble the drive.

7.7.3.4 Replacing the fan of the additional cabinet section of the sine filter

The sine filter option (+COSI) comes installed in an additional cabinet section that has a fan.

REPLACING THE FAN, SINE FILTER OPTION

- 1 Remove the touch shield.
- 2 Disconnect the cables of the fan unit. Remove the 4 screws that hold the fan unit.

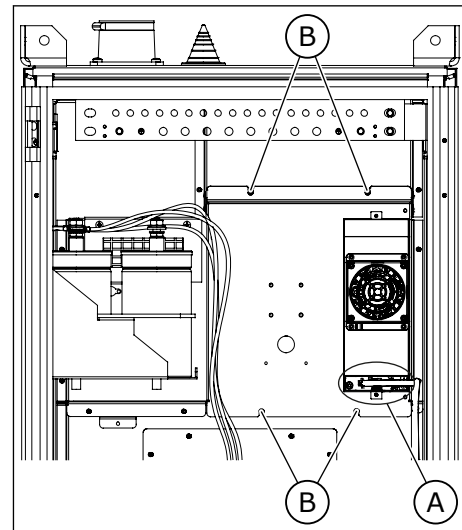

A. The cables of the fan
B. The 4 screws

3 Lift off the fan unit.

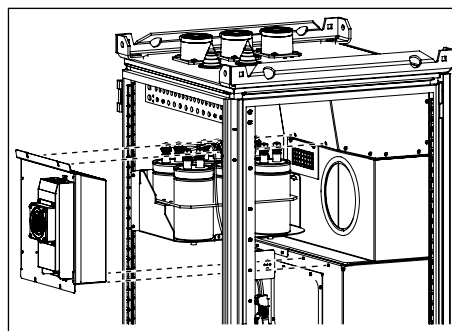

4 To release the fan from the fan unit, remove 8 screws.

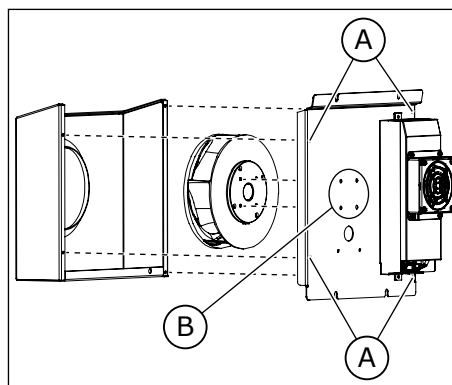

A. 4 screws
B. 4 screws

5 Replace the fan.

6 Re-assemble the drive and connect the cables.

7 Put the touch shield back.

7.7.4 REPLACING THE POWER UNIT OF THE AC DRIVE

7.7.4.1 Replacing the power unit, MR8



WARNING!

Before you start replacing the power unit, make sure that there is no input voltage coming into the cabinet. Switch off the voltage at the power source. Replacing the power unit when there is voltage in the cabinet can cause injury or death.

1 Remove the protective covers of the drive.

2 Disconnect all the power cables from the bottom of the power unit.

- 3 Remove the 2 screws from the top of the power unit.

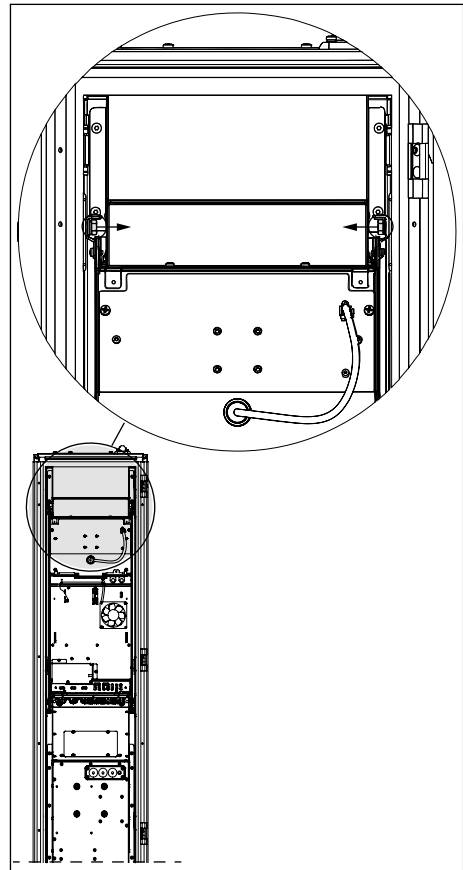

- 4 Remove the 6 screws from the bottom of the power unit.

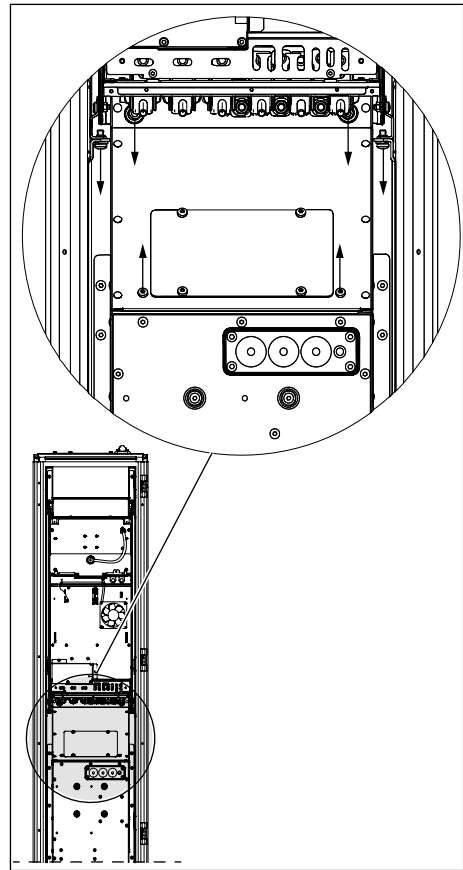

- 5 Pull the power unit out carefully until it is possible to use the front lifting holes.

- 6 Attach the lifting hooks to the front lifting holes and lift the power unit out of the cabinet.



WARNING!

Make sure that the lifting ropes are tight, and be careful when you lift the power unit. If the power unit falls off the cabinet rails and/or swings uncontrollably, it can cause injury to personnel and/or damage to equipment.

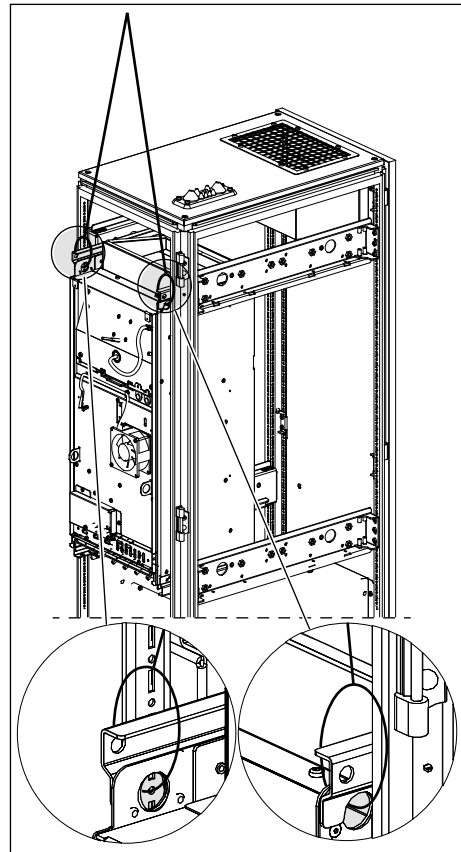

7.7.4.2 Replacing the power unit, MR9 and MR11



WARNING!

Before you start replacing the power unit, make sure that there is no input voltage coming into the cabinet. Switch off the voltage at the power source. Replacing the power unit when there is voltage in the cabinet can cause injury or death.

- 1 Remove the protective covers of the drive. To remove the touch protection, loosen eight screws.

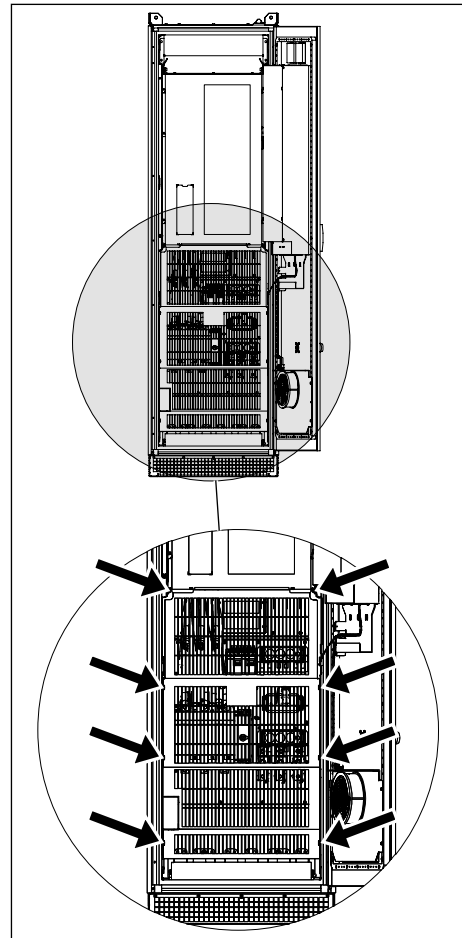

- 2 In MR9B, remove the air guide plate by taking six screws away (three pieces from the left side and three pieces from the right side) and lifting away the air guide plate.

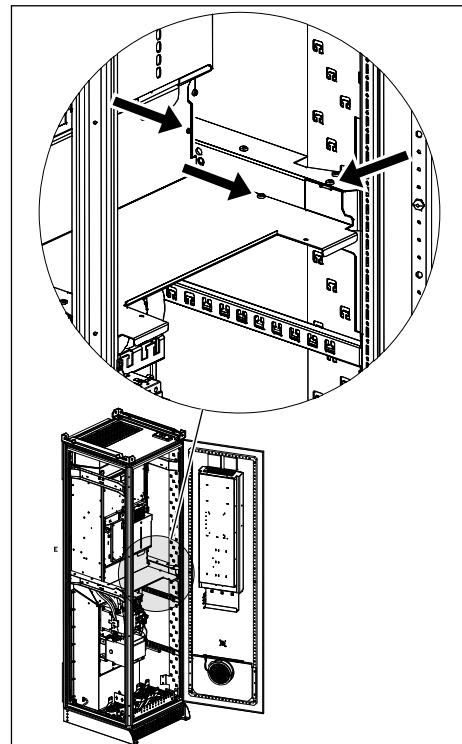

- 3 Disconnect all the power cables from the bottom of the power unit.
- 4 Remove the 2 screws from the top of the power unit. Also remove the lifting lugs. You will re-attach them later.

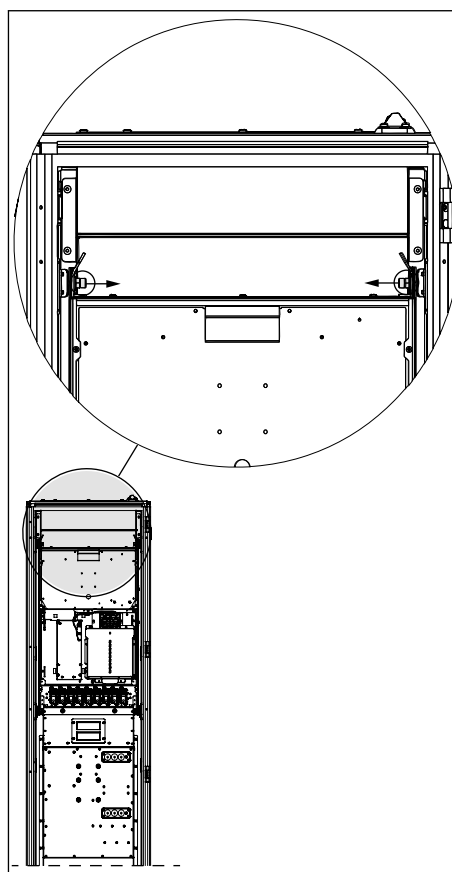

- 5 Remove the 8 screws from the bottom of the power unit.

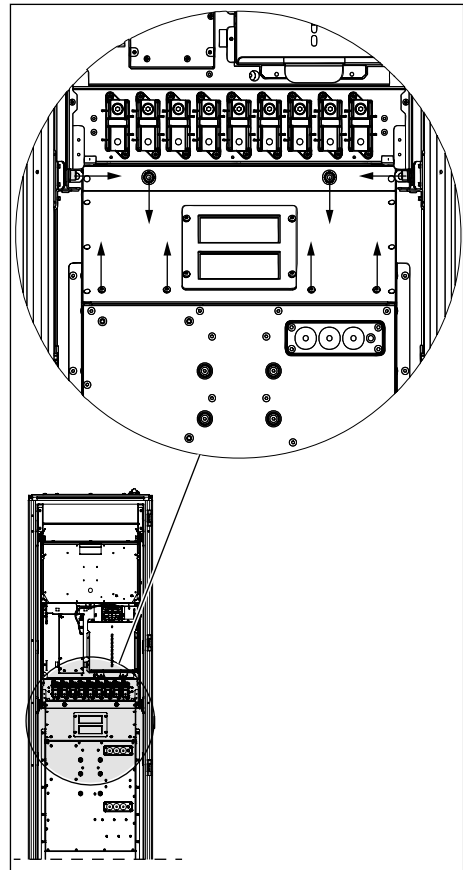

- 6 Pull the power unit out carefully until it is possible to re-attach the lifting lugs.

- 7 Re-attach the lifting lugs. You can use the extra nut that is on the screw. Remove the nut and attach it to the other side of the lifting lug.

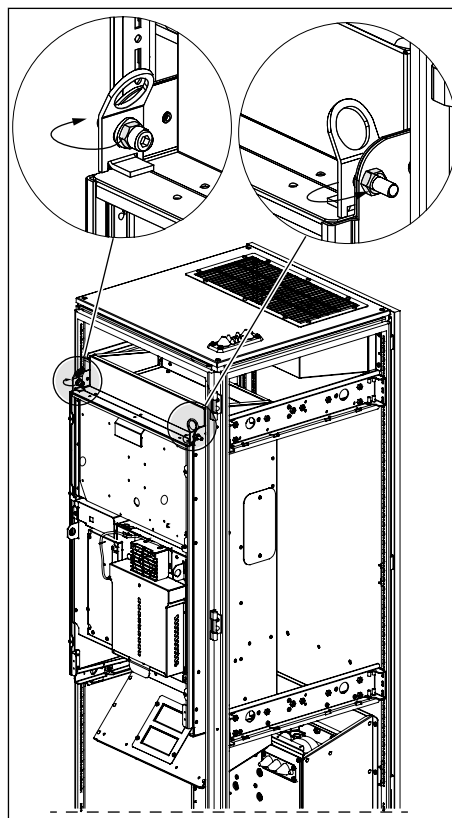

- 8 Attach the lifting hooks to the lifting lugs and lift the power unit out of the cabinet.

**WARNING!**

Make sure that the lifting ropes are tight, and be careful when you lift the power unit. If the power unit falls off the cabinet rails and/or swings uncontrollably, it can cause injury to personnel and/or damage to equipment.

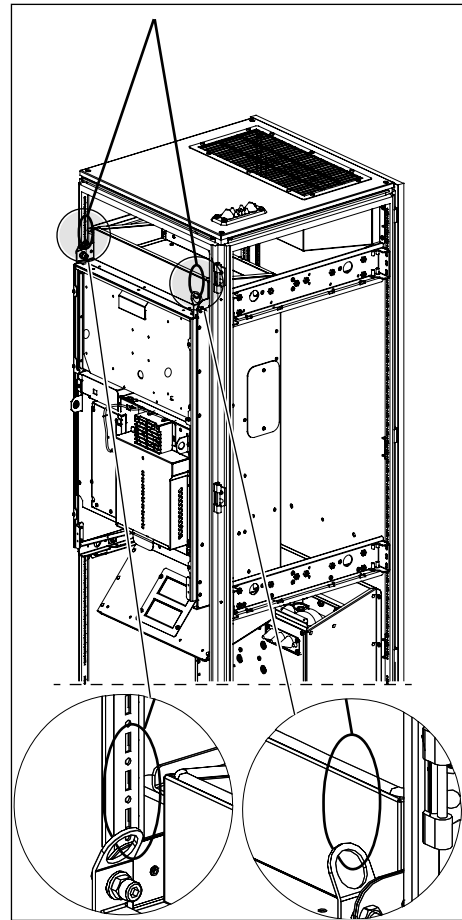

7.7.4.3 Replacing the power unit, MR10 and MR12

**WARNING!**

Before you start replacing the power unit, make sure that there is no input voltage coming into the cabinet. Switch off the voltage at the power source. Replacing the power unit when there is voltage in the cabinet can cause injury or death.

- 1 Remove the protective covers of the drive.
 - In MR12, do these steps for each cabinet.

- 2 Remove the 4 screws of the lower cover of the power unit and remove the cover.

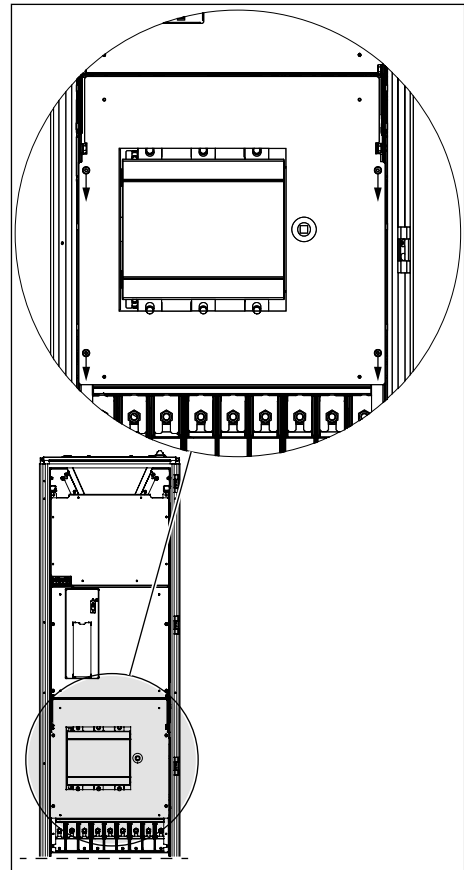

- 3 Disconnect all the power cables from the bottom of the power unit.
- 4 Remove the 2 screws from the top of the power unit.

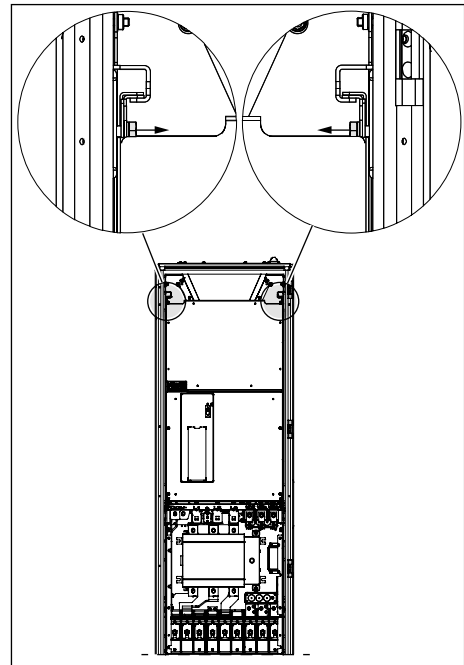

- 5 Remove the 2 screws from the bottom of the power unit.

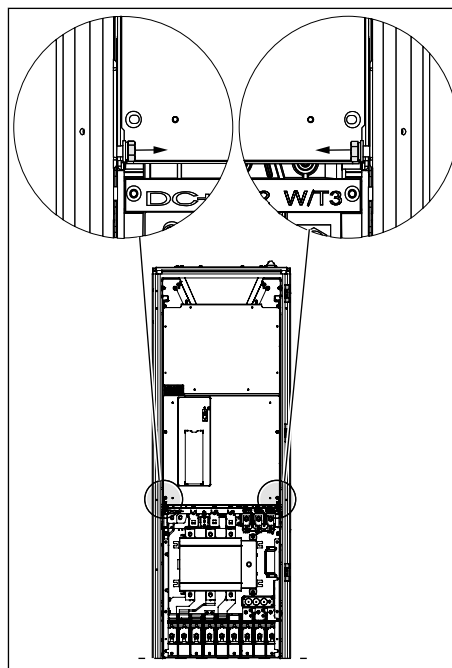

- 6 Pull the power unit out carefully until the front lifting holes are available.
7 Attach the lifting hooks to the front lifting holes and lift the power unit out of the cabinet.



WARNING!

Make sure that the lifting ropes are tight, and be careful when you lift the power unit. If the power unit falls off the cabinet rails and/or swings uncontrollably, it can cause injury to personnel and/or damage to equipment.

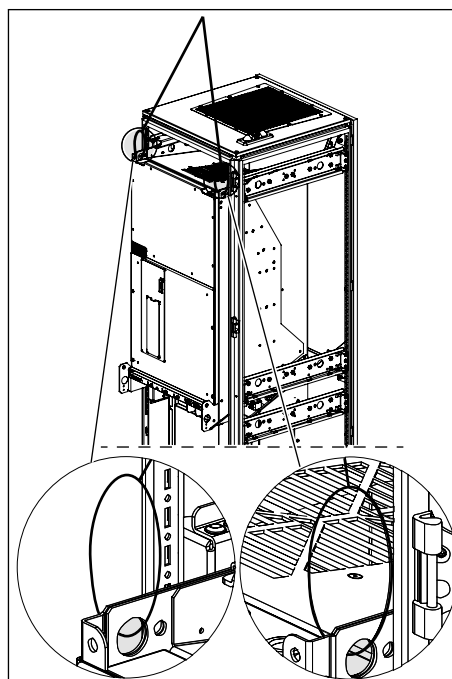

7.7.5 DOWNLOADING THE SOFTWARE

When it is necessary to get a new version of the software of the drive, obey these instructions. For more information, speak to the manufacturer.

Before you start to download the software, read these warnings and the warnings in Chapter 2 *Safety*.

**WARNING!**

Do not touch the internal components or the circuit boards of the drive when the drive is connected to mains. These components are live. A contact with this voltage is very dangerous.

**WARNING!**

Do not make connections to or from the AC drive when it is connected to mains. There is a dangerous voltage.

**WARNING!**

To do work on the connections of the drive, disconnect the drive from mains. Wait 5 minutes before you open the cabinet door or the cover of the drive. Then use a measuring device to make sure that there is no voltage. The connections of the drive are live 5 minutes after it is disconnected from mains.

**WARNING!**

Before you do electrical work, make sure that there is no voltage.

DOWNLOADING WITH MAINS, MR8-MR12

When the drive is supplied from mains, you can download a new software with the VACON® Loader PC tool and a CAB-USB/RS485 cable.

- 1 To download a new software, connect the PC into the control panel connector with the CAB-USB/RS485 cable.
 - The downloading time:
 - MR8 and MR9A: approximately 6 minutes
 - MR9B: approximately 12 minutes
 - MR10: approximately 12 minutes
 - MR11: approximately 25 minutes
 - MR12: approximately 25 minutes

When the drive is not supplied from mains, there are 2 alternatives to download the software.

1. The first is to use the Software Service Kit. The kit enables the power-up of the control board without the power-up of the drive, and enables you to download the software. Refer to the Software Service Kit User Manual for more information. In MR10 and MR12, you must also connect an external 24 VDC into the connector X50 on the measurement board.
2. The second alternative is to use an external 24 VDC power supply. Refer to the instructions below.

DOWNLOADING WITHOUT MAINS, MR8-MR12

When the drive is not supplied from mains, use an external 24 VDC power supply to do power-up to the control unit. In MR8 and MR9, the external 24 VDC does power up to the control unit, and in MR10 and MR12, it does power up to the control unit and the measurement board(s). After the power-up you can download the software.

The requirements for the 24 VDC power supply:

- A voltage accuracy +/-10%
 - MR8 and MR9A: > 1000 mA
 - MR9B: > 2000 mA
 - MR10: > 2000 mA
 - MR11: > 4000 mA
 - MR12: > 4000 mA
- 1 In MR8 and MR9, connect an external 24 VDC power supply into the control terminals 13 and 30. Connect the external GND potential into terminal 13, and the external 24 VDC (+) potential into terminal 30. See the terminals in *Fig. 46* and *Fig. 47*.
 - 2 In MR10 and MR12, loosen the screws of the service lid and remove it.
 - In MR12, there are two power units. Do the steps 2 and 3 for the two power units.

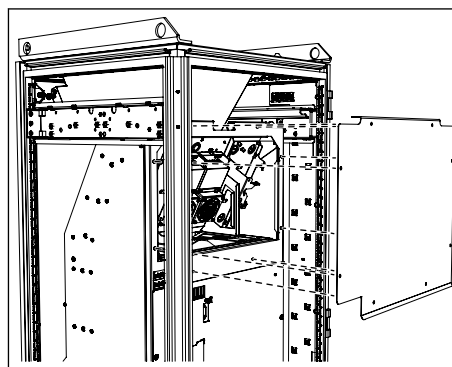

- 3 In MR9B, MR10 and MR12, connect an external 24 VDC into the connector X50 on the measurement board. The connector pins are X50-22 (+) and X50-23 (-).
 - In MR12, connect the external 24 VDC to the two X50 connectors.

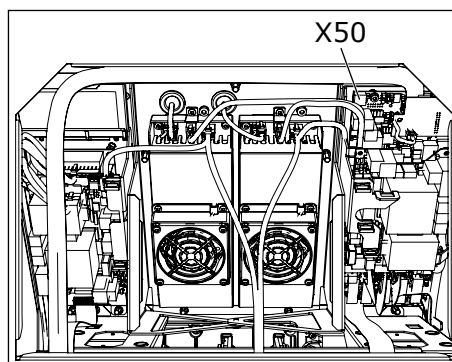

NOTE!

The size of the power supply wire for the external 24 VDC must be a minimum of 1 mm². The length of the wire from the 24 VDC power supply to the X50 connectors and to the control unit connectors must be a maximum of 3 m.

- 4 In all the enclosure sizes, do power-up to the external 24 VDC power supply.
- 5 Remove the control panel. Connect the PC to the control panel connector in the control unit with an CAB-USB/RS485 cable.
- 6 Start the VACON® Loader PC tool.
- 7 Start the downloading of the software.

- 8 After the downloading is complete, disconnect the PC and attach the control panel into the control unit.
- 9 Do power-down to the external 24 VDC power supply.
- 10 In MR8 and MR9, remove the external 24 VDC power supply wires from the terminals. (Unless the control unit of the drive is normally supplied with an external 24 VDC supply.)
- 11 In MR9B, MR10 and MR12, remove the external 24 VDC wires from the X50 connector of the measurement board. In MR11 and MR12, there are two X50 connectors.
- 12 In MR10 and MR12, attach the service lid. In MR12, there are two service lids.
- 13 After the downloading procedure is complete, start the Startup wizard (see the Application Manual).

**WARNING!**

Before you connect the drive to mains, make sure that the front cover and the cable cover of the drive are closed. The connections of the AC drive are live when the drive is connected to mains.

8 TECHNICAL DATA, VACON® 100 INDUSTRIAL

8.1 AC DRIVE POWER RATINGS

8.1.1 MAINS VOLTAGE 380-500 V

Table 29: The power ratings of VACON® 100 INDUSTRIAL in mains voltage 380-500V, 50-60 Hz, 3~

Enclosure size	Drive type	Loadability							Motor shaft power			
		Low			High			Max current Is 2s	400 V mains		480 V mains	
		Continuous current I _{Lout} [A]	Input current I _{Lin} [A]	10% over-load current [A]	Continuous current I _{Hout} [A]	Input current I _{Hin} [A]	50% over-load current [A]		10% over-load 40°C [kW]	50% over-load 40°C [kW]	10% over-load 40°C [hp]	50% over-load 40°C [hp]
MR8	0140	140.0	139.4	154.0	105.0	109.0	157.5	210.0	75.0	55.0	100.0	75.0
	0170	170.0	166.5	187.0	140.0	139.4	210.0	280.0	90.0	75.0	125.0	100.0
	0205	205.0	199.6	225.5	170.0	166.5	255.0	340.0	110.0	90.0	150.0	125.0
MR9A	0261	261.0	258.0	287.1	205.0	204.0	307.5	410.0	132.0	110.0	200.0	150.0
	0310	310.0	303.0	341.0	251.0	246.0	376.5	502.0	160.0	132.0	250.0	200.0
MR9B	0386	385.0	385.0	423.5	310.0	311.0	465.0	620.0	200.0	160.0	300.0	250.0
MR10	0385	385.0	385.0	423.5	310.0	311.0	465.0	620.0	200.0	160.0	300.0	250.0
	0460	460.0	460.0	506.0	385.0	391.0	577.5	770.0	250.0	200.0	350.0	300.0
	0520	520.0	520.0	572.0	460.0	459.0	690.0	920.0	250.0	250.0	450.0	350.0
	0590*	590.0	590.0	649.0	520.0	515.0	780.0	1040.0	315.0	250.0	500.0	450.0
MR111	0651	650.0	648.0	715.0	590.0	587.0	885.0	1180.0	355.0	315.0	500.0	500.0
	0731	730.0	724.0	803.0	650.0	642.0	975.0	1300.0	400.0	355.0	600.0	500.0
MR12	0650	650.0	648.0	715.0	590.0	587.0	885.0	1180.0	355.0	315.0	500.0	500.0
	0730	730.0	724.0	803.0	650.0	642.0	975.0	1300.0	400.0	355.0	600.0	500.0
	0820	820.0	822.0	902.0	730.0	731.0	1095.0	1460.0	450.0	400.0	700.0	600.0
	0920	920.0	916.0	1012.0	820.0	815.0	1230.0	1640.0	500.0	450.0	800.0	700.0
	1040*	1040.0	1030.0	1144.0	920.0	908.0	1380.0	1840.0	560.0	500.0	900.0	800.0
	1180*	1180.0	1164.0	1298.0	920.0	908.0	1380.0	1840.0	630.0	500.0	1000.0	800.0

* = These currents are not available when you have both the back channel cooling and du/dt filter (+CHCB and +PODU).

8.1.2 MAINS VOLTAGE 525-690 V

Table 30: The power ratings of VACON® 100 INDUSTRIAL in mains voltage 525-690 V, 50-60 Hz, 3~

Enclosure size	Drive type	Loadability							Motor shaft power			
		Low			High			Max current I _s 2s	600 V mains		690 V mains	
		Continuous current I _{Lout} [A]	Input current I _{Lin} [A]	10% overload current [A]	Continuous current I _{Hout} [A]	Input current I _{Hin} [A]	50% overload current [A]		10% overload 40°C [hp]	50% overload 40°C [hp]	10% overload 40°C [kW]	50% overload 40°C [kW]
MR8	0080	80.0	90.0	88.0	62.0	72.0	93.0	124.0	75.0	60.0	75.0	55.0
	0100	100.0	106.0	110.0	80.0	89.0	120.0	160.0	100.0	75.0	90.0	75.0
	0125	125.0	127.0	137.5	100.0	104.0	150.0	200.0	125.0	100.0	110.0	90.0
MR9A	0144	144.0	156.0	158.4	125.0	140.0	187.5	250.0	150.0	125.0	132.0	110.0
	0170	170.0	179.0	187.0	144.0	155.0	216.0	288.0	-	-	160.0	132.0
	0208	208.0	212.0	228.8	170.0	177.0	255.0	340.0	200.0	150.0	200.0	160.0
MR9B	0262	261.0	272.0	287.1	208.0	223.0	312.0	416.0	250.0	200.0	250.0	200.0
MR10	0261	261.0	272.0	287.1	208.0	223.0	312.0	416.0	250.0	200.0	250.0	200.0
	0325	325.0	330.0	357.5	261.0	269.0	391.5	522.0	300.0	250.0	315.0	250.0
	0385	385.0	386.0	423.5	325.0	327.0	487.5	650.0	400.0	300.0	355.0	315.0
	0416*	416.0	415.0	457.6	385.0	382.0	577.5	770.0	450.0	300.0	400.0	355.0
MR11	0461	460.0	477.0	506.0	416.0	433.0	624.0	832.0	450.0	400.0	450.0	400.0
	0521	520.0	535.0	572.0	460.0	472.0	690.0	920.0	500.0	450.0	500.0	450.0
MR12	0460	460.0	477.0	506.0	416.0	433.0	624.0	832.0	450.0	400.0	450.0	400.0
	0520	520.0	532.0	572.0	460.0	472.0	690.0	920.0	500.0	450.0	500.0	450.0
	0590	590.0	597.0	649.0	520.0	527.0	780.0	1040.0	600.0	500.0	560.0	500.0
	0650	650.0	653.0	715.0	590.0	591.0	885.0	1180.0	650.0	600.0	630.0	560.0
	0750*	750.0	747.0	825.0	650.0	646.0	975.0	1300.0	700.0	650.0	710.0	630.0
	0820*	820.0	813.0	902.0	650.0	739.0	975.0	1300.0	800.0	650.0	800.0	630.0

* = These currents are not available when you have both the back channel cooling and du/dt filter (+CHCB and +PODU).

8.1.3 BRAKE RESISTOR RATINGS

Make sure that the resistance is higher than the set minimum resistance. The power handling capacity must be sufficient for the application.

Table 31: The recommended brake resistor types and the calculated resistance of the drive, 380-500 V

Enclosure size	Duty cycle	Type of brake resistor	Resistance [Ω]
MR8	Light duty	BRR 0105 LD 5	6.5
	Heavy duty	BRR 0105 HD 5	6.5
MR9A	Light duty	BRR 0300 LD 5	3.3
	Heavy duty	BRR 0300 HD 5	3.3
MR9B	Light duty	BRR 0520 LD 5	1.4
	Heavy duty	BRR 0520 HD 5	1.4
MR10	Light duty	BRR 0520 LD 5	1.4
	Heavy duty	BRR 0520 HD 5	1.4
MR11	Light duty	BRR 0520 LD 5	2 x 1.4
	Heavy duty	BRR 0520 HD 5	2 x 1.4
MR12	Light duty	BRR 0520 LD 5	2 x 1.4
	Heavy duty	BRR 0520 HD 5	2 x 1.4

Table 32: The recommended brake resistor types and the calculated resistance of the drive, 525-690 V

Enclosure size	Drive type	Duty cycle	Type of brake resistor	Resistance [Ω]
MR8	0080	Light duty	BRR 0052 LD 6	18
		Heavy duty	BRR 0052 HD 6	18
	0100-0125	Light duty	BRR 0100 LD 6	9
		Heavy duty	BRR 0100 HD 6	9
MR9A	0144	Light duty	BRR 0100 LD 6	9
		Heavy duty	BRR 0100 HD 6	9
	0170-0208	Light duty	BRR 0208 LD 6	7
		Heavy duty	BRR 0208 HD 6	7
MR9B	0262	Light duty	BRR 0416 LD 6	2.5
		Heavy duty	BRR 0416 HD 6	2.5
MR10	0261-0416	Light duty	BRR 0416 LD 6	2.5
		Heavy duty	BRR 0416 HD 6	2.5
MR11	0460-0520	Light duty	BRR 0416 LD 6	2 x 2.5
		Heavy duty	BRR 0416 HD 6	2 x 2.5
MR12	0460-0820	Light duty	BRR 0416 LD 6	2 x 2.5
		Heavy duty	BRR 0416 HD 6	2 x 2.5

The enclosure size MR12 includes 2 power units, each of which has a brake chopper. The brake choppers must have their own brake resistors. See *Fig. 42 The inside layout of MR12, without protective covers.*

- The light duty cycle is for brake resistor cyclic use (1 LD pulse in a 120-second period). The light duty resistor is rated for a 5-second ramp from full power to 0.
- The heavy duty cycle is for brake resistor cyclic use (1 HD pulse in a 120-second period). The heavy duty resistor is rated for a 3-second full power braking with a 7-second ramp to 0.

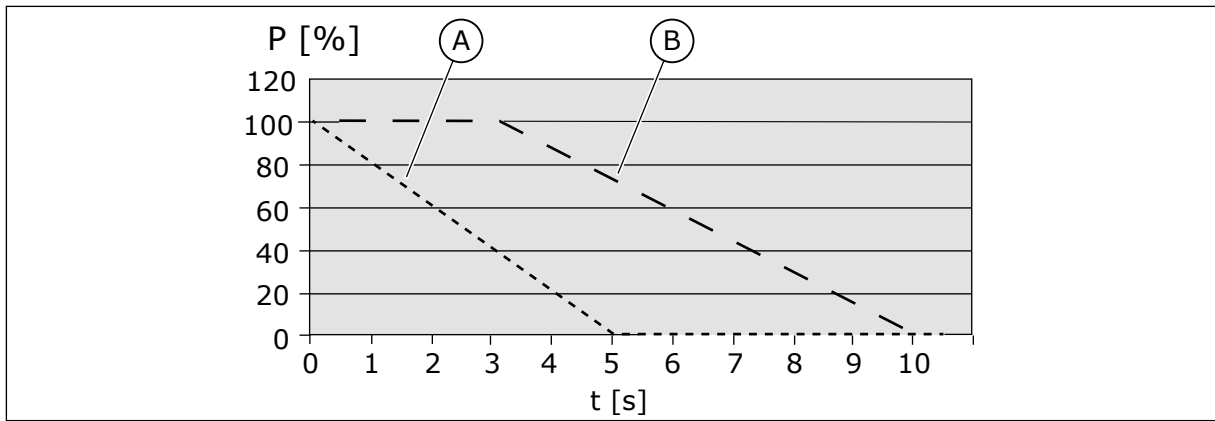

Fig. 59: The LD and HD pulses

A. Light duty

B. Heavy duty

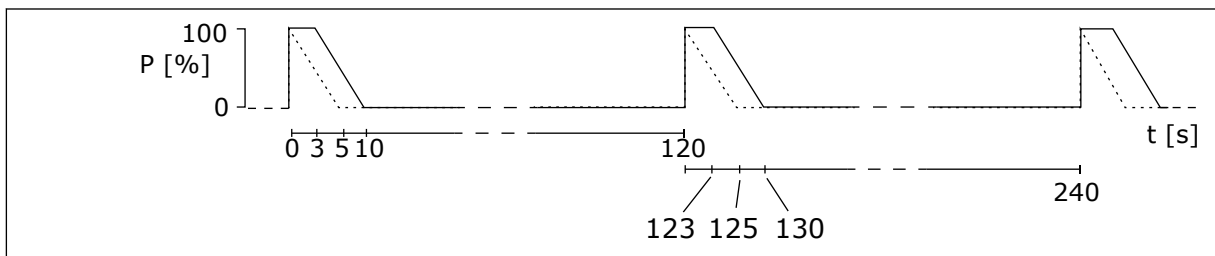

Fig. 60: The duty cycles of the LD and HD pulses

Table 33: The minimum resistance and the brake power, mains voltage 380-500 V

Enclosure size	The minimum brake resistance [Ω]	Brake power* @845 VDC [kW]
MR8	6.5	109.9
MR9A	3.3	216.4
MR9B	1.4	250
MR10	1.4	400
MR11	2 x 1.4 **	500
MR12	2 x 1.4 **	800

Table 34: The minimum resistance and the brake power, mains voltage 525-690 V

Enclosure size	The minimum brake resistance [Ω]	Brake power* @1166 VDC [kW]
MR8	9	110
MR9A	7	193
MR9B	2.5	250
MR10	2.5	400
MR11	2 x 2.5 **	500
MR12	2 x 2.5 **	800

* = When you use recommended resistor types.

** = The MR11 and MR12 must have 2 brake resistors.

8.2 VACON® 100 INDUSTRIAL - TECHNICAL DATA

Table 35: The technical data of the VACON® 100 INDUSTRIAL AC drive

Technical item or function	Technical data	
Mains connection	Input voltage U_{in}	380-500 V, 525-690 V, -10%...+10%
	Input frequency	50-60 Hz, -5...+10%
	Connection to mains	Once per minute or less frequently
	Starting delay	8 s (MR8 to MR12)
	Mains	<ul style="list-style-type: none"> Mains types: TN, TT, and IT Short circuit current: the maximum short circuit current must be < I_{cc} 65 kA.
Motor connection	Output voltage	0- U_{in}
	Continuous output current	IL: Ambient temperature maximum +40°C overload 1.1 x IL (1 min/10 min) IH: Ambient temperature maximum +40°C overload 1.5 x IH (1 min/10 min) IH in 690 V drives: Ambient temperature max. +40°C overload 1.5 x IH (1 min/10 min)
	Output frequency	0-320 Hz (standard)
	Frequency resolution	0.01 Hz

Table 35: The technical data of the VACON® 100 INDUSTRIAL AC drive

Technical item or function	Technical data
Control characteristics	<p>Switching frequency (see parameter P3.1.2.3)</p> <p>380-500 V</p> <ul style="list-style-type: none"> • MR8-MR12: <ul style="list-style-type: none"> • 1.5-6 kHz • Default: MR8: 3 kHz, MR9: 2 kHz, MR10: 2 kHz, MR11: 2 kHz, MR12: 2 kHz <p>525-690 V</p> <ul style="list-style-type: none"> • MR8-MR12: <ul style="list-style-type: none"> • 1.5-6 kHz • Default: 2 kHz • For a product that is configured for a C4 installation on IT network the maximum switching frequency is limited to default 2kHz. <p>Automatic switching frequency derating in case of overload.</p>
Frequency reference: Analogue input Panel reference	Resolution 0.1% (10-bit), accuracy ±1% Resolution 0.01 Hz
Field weakening point	8-320 Hz
Acceleration time	0.1-3000 s
Deceleration time	0.1-3000 s

Table 35: The technical data of the VACON® 100 INDUSTRIAL AC drive

Technical item or function	Technical data
Ambient conditions	Ambient operating temperature IL current: -10°C (no frost)...+40 °C IH current: -10°C (no frost)...+40 °C Maximum operating temperature: +50°C with derating (1.5%/1°C) Drives with safety-related options have a maximum ambient temperature of 40 °C.
	Storage temperature -40°C...+70°C
	Relative humidity 0-95% RH, non-condensing, non-corrosive
	Air quality Tested according to IEC 60068-2-60 Test Ke: Flowing mixed gas corrosion test, Method 1 (H ₂ S [hydrogen sulfide] and SO ₂ [sulfur dioxide]) Designed according to <ul style="list-style-type: none"> • Chemical vapours: IEC 60721-3-3, unit in operation, class 3C2 • Mechanical particles: IEC 60721-3-3, unit in operation, class 3S2
	Altitude 100% load capacity (no derating) up to 1000 m 1% derating for each 100m above 1000 m Maximum altitudes: <ul style="list-style-type: none"> • 380-500 V: 4000 m (TN and IT systems) • 380-500 V: 2000 m (corner-grounded network) • 525-690 V: 2000 m (TN and IT systems, no corner grounding) Voltage for relay outputs: <ul style="list-style-type: none"> • Up to 3000 m : Allowed up to 240 V • 3000-4000 m: Allowed up to 120 V Corner-grounding: <ul style="list-style-type: none"> • up to 2000 m only (Requires a change in the EMC level from C3 to C4, see 7.5 <i>Installation in a corner-grounded network.</i>)
	Pollution degree IP21: PD2 IP54: PD3

Table 35: The technical data of the VACON® 100 INDUSTRIAL AC drive

Technical item or function	Technical data	
Ambient conditions	Vibration: EN61800-5-1 EN60068-2-6	5-150 Hz Displacement amplitude 0.5 mm (peak) at 5-22 Hz Maximum acceleration amplitude 1 G at 22-150 Hz
	Shock: EN60068-2-27	UPS Drop Test (for applicable UPS weights) Storage and shipping: maximum 15 G, 11 ms (in package)
	Enclosure class	IP21: standard IP54: option
EMC (at default settings)	Immunity	Fulfils EN61800-3, 1st and 2nd environment
	Emissions	<ul style="list-style-type: none"> • 380-500 V: EN 61800-3 (2004), category C3, if the drive is correctly installed. • 525-690 V: EN 61800-3 (2004), category C3, if the drive is correctly installed. • All: The drive can be changed to C4 for IT type mains. See chapter 7.6 <i>Installation in an IT system</i>.
Noise level	Average noise level (min-max) sound pressure level in dB(A)	The sound pressure depends on the cooling fan speed, which is controlled in accordance with the drive temperature. MR8: 58-73 MR9: 54-75 MR10/MR12: 58-75
Safety		EN 61800-5-1, CE (See the nameplate of the drive for more approvals.)

Table 35: The technical data of the VACON® 100 INDUSTRIAL AC drive

Technical item or function		Technical data
Protections	Overvoltage trip limit	Mains voltage 500 V: 911 VDC Mains voltage 690 V: 1258 VDC
	Undervoltage trip limit	Depends on mains voltage (0.8775 x mains voltage): Mains voltage 400 V: trip limit 351 VDC Mains voltage 500 V: trip limit 438 VDC Mains voltage 525 V: trip limit 461 VDC Mains voltage 690 V: trip limit 606 VDC
	Earth fault protection	Yes
	Mains supervision	Yes
	Motor phase supervision	Yes
	Overcurrent protection	Yes
	Unit overtemperature protection	Yes
	Motor overload protection	Yes. * The motor overload protection activates at 110% of the full load current.
	Motor stall protection	Yes
	Motor underload protection	Yes
	Short-circuit protection of +24 V and +10 V reference voltages	Yes

* = For the motor thermal memory and the memory retention function to obey the UL 61800-5-1 requirements, you must use the system software version FW0072V007 or a newer version. If you use an older system software version, you must install a motor overtemperature protection to obey the UL regulations.

9 TECHNICAL DATA, VACON® 100 FLOW

9.1 AC DRIVE POWER RATINGS

9.1.1 MAINS VOLTAGE 380-500 V

Table 36: The power ratings of VACON® 100 FLOW in mains voltage 380-500 V, 50-60 Hz, 3~

Enclosure size	Drive type	Loadability				Motor shaft power	
		Continuous current I_{Lout} [A]	Input current I_{Lin} [A]	10% overload current [A]	Max current I_S 2s	400 V mains	480 V mains
						10% overload 40°C [kW]	10% overload 40°C [hp]
MR8	0140	140.0	139.4	154.0	210.0	75.0	100.0
	0170	170.0	166.5	187.0	280.0	90.0	125.0
	0205	205.0	199.6	225.5	340.0	110.0	150.0
MR9A	0261	261.0	258.0	287.1	410.0	132.0	200.0
	0310	310.0	303.0	341.0	502.0	160.0	250.0
MR9B	0386	385.0	386.0	423.5	620.0	200.0	300.0
MR10	0385	385.0	385.0	423.5	620.0	200.0	300.0
	0460	460.0	460.0	506.0	770.0	250.0	350.0
	0520	520.0	520.0	572.0	920.0	250.0	450.0
	0590*	590.0	590.0	649.0	1040.0	315.0	500.0
MR11	0651	650.0	648.0	715.0	1180.0	355.0	500.0
	0731	730.0	724.0	803.0	1300.0	400.0	600.0
MR12	0650	650.0	648.0	715.0	1180.0	355.0	500.0
	0730	730.0	724.0	803.0	1300.0	400.0	600.0
	0820	820.0	822.0	902.0	1460.0	450.0	700.0
	0920	920.0	916.0	1012.0	1640.0	500.0	800.0
	1040*	1040.0	1030.0	1144.0	1840.0	560.0	900.0
	1180*	1180.0	1164.0	1298.0	1840.0	630.0	1000.0

* = These currents are not available when you have both the back channel cooling and du/dt filter (+CHCB and +PODU).

9.1.2 MAINS VOLTAGE 525-690 V

Table 37: The power ratings of VACON® 100 FLOW in mains voltage 525-690 V, 50-60 Hz, 3~

Enclosure size	Drive type	Loadability				Motor shaft power	
		Continuous current I_{Lout} [A]	Input current I_{Lin} [A]	10% overload current [A]	Max current I_S 2s	600 V mains	690 V mains
						10% overload 40°C [hp]	10% overload 40°C [kW]
MR8	0080	80.0	90.0	88.0	124.0	75.0	75.0
	0100	100.0	106.0	110.0	160.0	100.0	90.0
	0125	125.0	127.0	137.5	200.0	125.0	110.0
MR9A	0144	144.0	156.0	158.4	250.0	150.0	132.0
	0170	170.0	179.0	187.0	288.0	-	160.0
	0208	208.0	212.0	228.8	340.0	200.0	200.0
MR9B	0262	261.0	272.0	287.1	416.0	250.0	250.0
MR10	0261	261.0	272.0	287.1	416.0	250.0	250.0
	0325	325.0	330.0	357.5	522.0	300.0	315.0
	0385	385.0	386.0	423.5	650.0	400.0	355.0
	0416*	416.0	415.0	457.6	770.0	450.0	400.0
MR11	0461	460.0	477.0	506.0	832.0	450.0	450.0
	0521	520.0	532.0	572.0	920.0	500.0	500.0
MR12	0460	460.0	477.0	506.0	832.0	450.0	450.0
	0520	520.0	532.0	572.0	920.0	500.0	500.0
	0590	590.0	597.0	649.0	1040.0	600.0	560.0
	0650	650.0	653.0	715.0	1180.0	650.0	630.0
	0750*	750.0	747.0	825.0	1300.0	700.0	710.0
	0820*	820.0	813.0	902.0	1300.0	800.0	800.0

* = These currents are not available when you have both the back channel cooling and du/dt filter (+CHCB and +PODU).

9.2 VACON® 100 FLOW - TECHNICAL DATA

Table 38: The technical data of the VACON® 100 FLOW AC drive

Technical item or function		Technical data
Mains connection	Input voltage U_{in}	380-500 V, 525-690 V, -10%...+10%
	Input frequency	50-60 Hz, -5...+10%
	Connection to mains	Once per minute or less frequently
	Starting delay	8 s (MR8 to MR12)
	Mains	<ul style="list-style-type: none"> • Mains types: TN, TT, and IT • Short circuit current: the maximum short circuit current must be < I_{cc} 65 kA.
Motor connection	Output voltage	0- U_{in}
	Continuous output current	I_L : Ambient temperature maximum +40°C overload 1.1 x I_L (1 min/10 min)
	Output frequency	0-320 Hz (standard)
	Frequency resolution	0.01 Hz

Table 38: The technical data of the VACON® 100 FLOW AC drive

Technical item or function	Technical data
Control qualities	<p>Switching frequency (see parameter P3.1.2.3)</p> <p>380-500 V</p> <ul style="list-style-type: none"> • MR8-MR12: <ul style="list-style-type: none"> • 1.5-6 kHz • Default: MR8: 3 kHz, MR9: 2 kHz, MR10: 2 kHz, MR11: 2 kHz, MR12: 2 kHz <p>525-690 V</p> <ul style="list-style-type: none"> • MR8-MR12: <ul style="list-style-type: none"> • 1.5-6 kHz • Default: 2 kHz • For a product that is configured for a C4 installation on IT network the maximum switching frequency is limited to default 2kHz. <p>Automatic switching frequency derating in case of overload.</p>
Frequency reference: Analogue input Panel reference	Resolution 0.1% (10-bit), accuracy ±1% Resolution 0.01 Hz
Field weakening point	8-320 Hz
Acceleration time	0.1-3000 s
Deceleration time	0.1-3000 s

Table 38: The technical data of the VACON® 100 FLOW AC drive

Technical item or function	Technical data
Ambient conditions	Ambient operating temperature IL current: -10°C (no frost)...+40°C Maximum operating temperature: +50°C with derating (1.5%/1°C) Drives with safety-related options have a maximum ambient temperature of 40 °C.
	Storage temperature -40°C...+70°C
	Relative humidity 0-95% RH, non-condensing, non-corrosive
	Air quality Tested according to IEC 60068-2-60 Test Ke: Flowing mixed gas corrosion test, Method 1 (H ₂ S [hydrogen sulfide] and SO ₂ [sulfur dioxide]) Designed according to <ul style="list-style-type: none"> • Chemical vapours: IEC 60721-3-3, unit in operation, class 3C2 • Mechanical particles: IEC 60721-3-3, unit in operation, class 3S2
	Altitude 100% load capacity (no derating) up to 1000 m 1-% derating for each 100m above 1000 m Maximum altitudes: <ul style="list-style-type: none"> • 380-500 V: 4000 m (TN and IT systems) • 380-500 V: 2000 m (corner-grounded network) • 525-690 V: 2000 m (TN and IT systems, no corner grounding) Voltage for relay outputs: <ul style="list-style-type: none"> • Up to 3000 m : Allowed up to 240 V • 3000-4000 m: Allowed up to 120 V Corner-grounding: <ul style="list-style-type: none"> • up to 2000 m only (Requires a change in the EMC level from C3 to C4, see 7.5 <i>Installation in a corner-grounded network.</i>)
	Pollution degree IP21: PD2 IP54: PD3

Table 38: The technical data of the VACON® 100 FLOW AC drive

Technical item or function	Technical data	
Ambient conditions	Vibration: EN61800-5-1 EN60068-2-6	5-150 Hz Displacement amplitude 0.5 mm (peak) at 5-22 Hz Maximum acceleration amplitude 1 G at 22-150 Hz
	Shock: EN60068-2-27	UPS Drop Test (for applicable UPS weights) Storage and shipping: maximum 15 G, 11 ms (in package)
	Enclosure class	IP21: standard IP54: option
EMC (at default settings)	Immunity	Fulfil EN61800-3, 1st and 2nd environment
	Emissions	<ul style="list-style-type: none"> • 380-500 V: EN 61800-3 (2004), category C3, if the drive is correctly installed. • 525-690 V: EN 61800-3 (2004), category C3, if the drive is correctly installed. • All: The drive can be changed to C4 for IT type mains. See chapter 7.6 <i>Installation in an IT system</i>.
Noise level	Average noise level (min-max) sound pressure level in dB(A)	The sound pressure depends on the cooling fan speed, which is controlled in accordance with the drive temperature. MR8: 58-73 MR9/MR11: 54-75 MR10/MR12: 58-75
Safety		EN 61800-5-1, CE (See the nameplate of the drive for more approvals.)

Table 38: The technical data of the VACON® 100 FLOW AC drive

Technical item or function	Technical data	
Protections	Overvoltage trip limit	Mains voltage 500 V: 911 VDC Mains voltage 690 V: 1258 VDC
	Undervoltage trip limit	Depends on mains voltage (0.8775 x mains voltage): Mains voltage 400 V: trip limit 351 VDC Mains voltage 500 V: trip limit 438 VDC Mains voltage 525 V: trip limit 461 VDC Mains voltage 690 V: trip limit 606 VDC
	Earth fault protection	Yes
	Mains supervision	Yes
	Motor phase supervision	Yes
	Overcurrent protection	Yes
	Unit overtemperature protection	Yes
	Motor overload protection	Yes. * The motor overload protection activates at 110% of the full load current.
	Motor stall protection	Yes
	Motor underload protection	Yes
	Short-circuit protection of +24 V and +10 V reference voltages	Yes

* = For the motor thermal memory and the memory retention function to obey the UL 61800-5-1 requirements, you must use the system software version FW0159V003 or a newer version. If you use an older system software version, you must install a motor overtemperature protection to obey the UL regulations.

10 TECHNICAL DATA ON CONTROL CONNECTIONS

10.1 TECHNICAL DATA ON CONTROL CONNECTIONS

Table 39: The standard I/O board

Standard I/O board		
Terminal	Signal	Technical information
1	Reference output	+10 V, 0%...+3%, maximum current: 10 mA
2	Analogue input, voltage or current	Analogue input channel 1 0...+10 V (Ri = 200 kΩ) 4-20 mA (Ri =250 Ω) Resolution 0.1 %, accuracy ±1 % Selection V/mA with DIP switches (see chapter Selection of terminal functions with DIP switches in the Installation Manual).
3	Analogue input common (current)	Differential input if not connected to ground Allows ±20 V common mode voltage to GND
4	Analogue input, voltage or current	Analogue input channel 2 Default: 4-20 mA (Ri =250 Ω) 0-10 V (Ri=200 kΩ) Resolution 0.1 %, accuracy ±1 % Selection V/mA with DIP switches (see chapter Selection of terminal functions with DIP switches in the Installation Manual)
5	Analogue input common (current)	Differential input if not connected to ground Allows ±20 V common mode voltage to GND
6	24 V aux. voltage	+24 V, ±10%, max volt. ripple < 100 mVrms max. 250 mA Short-circuit protected
7	I/O ground	Ground for reference and controls (connected internally to frame ground through 1 MΩ)
8	Digital input 1	Positive or negative logic Ri = min. 5 kΩ 0-5 V = 0 15-30 V = 1
9	Digital input 2	
10	Digital input 3	

Table 39: The standard I/O board

Standard I/O board		
Terminal	Signal	Technical information
11	Common A for DIN1-DIN6	Digital inputs can be disconnected from ground, see chapter Isolation of digital inputs from ground in the Installation Manual.
12	24 V aux. voltage	+24 V, $\pm 10\%$, max volt. ripple < 100mVrms max. 250 mA Short-circuit protected
13	I/O ground	Ground for reference and controls (connected internally to frame ground through 1 M Ω)
14	Digital input 4	Positive or negative logic R _i = min. 5 k Ω 0-5 V = 0 15-30 V = 1
15	Digital input 5	
16	Digital input 6	
17	Common A for DIN1-DIN6	Digital inputs can be isolated from ground, see chapter Isolation of digital inputs from ground in the Installation Manual.
18	Analogue signal (+output)	Analogue output channel 1, selection 0 -20 mA, load <500 Ω Default: 0-20 mA 0-10 V Resolution 0.1 %, accuracy ± 2 % Selection V/mA with DIP switches (see chapter Selection of terminal functions with DIP switches in the Installation Manual) Short-circuit protected
19	Analogue output common	
30	24V auxiliary input voltage	Can be used as external power backup for the control unit
A	RS485	Differential receiver/transmitter Set bus termination with DIP switches (see chapter Selection of terminal functions with DIP switches in the Installation Manual). Termination resistance = 220 Ω
B	RS485	

Table 40: The standard relay board (+SBF3)

Terminal	Signal	Technical information
21	Relay output 1 *	Change-over contact (SPDT) relay. 5.5 mm isolation between channels. Switching capacity <ul style="list-style-type: none"> • 24 VDC/8 A • 250 VAC/8 A • 125 VDC/0.4 A Minimum switching load <ul style="list-style-type: none"> • 5 V/10 mA
22		
23		
24	Relay output 2 *	Change-over contact (SPDT) relay. 5.5 mm isolation between channels. Switching capacity <ul style="list-style-type: none"> • 24 VDC/8 A • 250 VAC/8 A • 125 VDC/0.4 A Minimum switching load <ul style="list-style-type: none"> • 5 V/10 mA
25		
26		
32	Relay output 3 *	Normally-open (NO or SPST) contact relay. 5.5 mm isolation between channels. Switching capacity <ul style="list-style-type: none"> • 24 VDC/8 A • 250 VAC/8 A • 125 VDC/0.4 A Minimum switching load <ul style="list-style-type: none"> • 5 V/10 mA
33		

* = If you use 230 VAC as control voltage from the output relays, the control circuitry must be powered with a separate isolation transformer to limit the short circuit current and the overvoltage spikes. This is to prevent welding on the relay contacts. Refer to standard EN 60204-1, section 7.2.9.

Table 41: The optional relay board (+SBF4)

Terminal	Signal	Technical information
21	Relay output 1 *	Change-over contact (SPDT) relay. 5.5 mm isolation between channels. Switching capacity <ul style="list-style-type: none"> • 24 VDC/8 A • 250 VAC/8 A • 125 VDC/0.4 A Minimum switching load <ul style="list-style-type: none"> • 5 V/10 mA
22		
23		
24	Relay output 2 *	Change-over contact (SPDT) relay. 5.5 mm isolation between channels. Switching capacity <ul style="list-style-type: none"> • 24 VDC/8 A • 250 VAC/8 A • 125 VDC/0.4 A Minimum switching load <ul style="list-style-type: none"> • 5 V/10 mA
25		
26		
28	TI1+ TI1-	Thermistor input Rtrip = 4.7 kΩ (PTC) Measuring voltage 3.5V
29		

* = If you use 230 VAC as control voltage from the output relays, the control circuitry must be powered with a separate isolation transformer to limit the short circuit current and the overvoltage spikes. This is to prevent welding on the relay contacts. Refer to standard EN 60204-1, section 7.2.9.

VACON®

www.danfoss.com

Vacon Ltd
Member of the Danfoss Group
Runsorintie 7
65380 Vaasa
Finland

Document ID:



DPD01666E

Rev. E

Sales code: DOC-INS100ED+DLUK