

**VACON<sup>®</sup> 100 INDUSTRIAL**  
**VACON<sup>®</sup> 100 FLOW**  
AC DRIVES

**INSTALLATION MANUAL**  
IPOO DRIVE MODULES



# PREFACE

Document ID: DPD01665C

Date: 15.2.2016

## ABOUT THIS MANUAL

This manual is copyright of Vacon Ltd. All Rights Reserved. The manual is subject to change without prior notice.

## ABOUT THE PRODUCT

This manual describes the Vacon 100 IP00 Drive Module. The drive has a power range of 75-800 kW, and a voltage range of 208-240 V, 380-500 V, or 525-690 V. The drive is available in 4 different enclosure sizes: MR8, MR9, MR10 and MR12. The enclosure class of the drive is IP00, and that is why the drive must be installed in a cabinet or other enclosure after delivery.

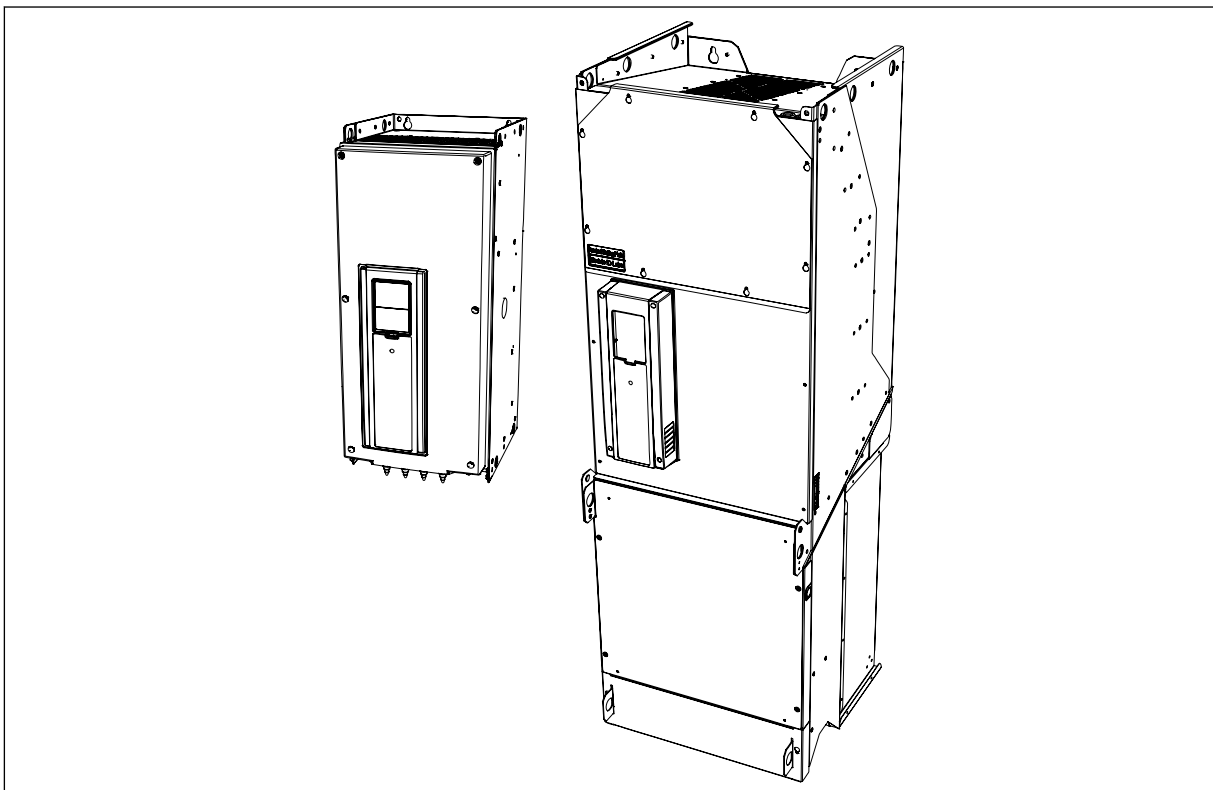

*Fig. 1: Examples of the Vacon 100 IP00 drive module*



# TABLE OF CONTENTS

## Preface

About this manual .....	3
About the product .....	3
<b>1 Approvals .....</b>	<b>7</b>
<b>2 Safety .....</b>	<b>9</b>
2.1 The safety symbols used in the manual .....	9
2.2 Warning .....	9
2.3 Caution .....	10
2.4 Grounding and earth fault protection .....	11
2.5 Using an RCD or an RCM device .....	12
<b>3 Receiving the delivery .....</b>	<b>13</b>
3.1 Package label .....	13
3.2 Type designation code .....	14
3.3 The contents of the delivery .....	14
3.4 Removing the packaging and lifting the AC drive .....	15
3.4.1 Weight of the AC drive .....	15
3.4.2 Lifting the IP00 drive module .....	15
3.5 "Product modified" label .....	18
3.6 Disposal .....	19
<b>4 Mounting dimensions .....</b>	<b>20</b>
4.1 Dimensions of MR8, IP00 .....	20
4.2 Dimensions of MR9, IP00 .....	21
4.3 Dimensions of MR10 and MR12, IP00 .....	22
<b>5 Installation into cabinet .....</b>	<b>25</b>
5.1 General information .....	25
5.1.1 General information about the installation, MR8-MR9 .....	25
5.1.2 General information about the installation, MR10 .....	26
5.1.3 General information about the installation, MR12 .....	29
5.2 Mechanical installation .....	31
5.2.1 Installing the IP00 drive module into the cabinet .....	32
5.2.2 Cooling and free space around the AC drive .....	34
<b>6 Power cabling .....</b>	<b>36</b>
6.1 Cable dimensioning and selection .....	36
6.1.1 Cable and fuse sizes .....	36
6.1.2 Cable and fuse sizes, North America .....	43
6.2 Brake resistor cables .....	48
6.3 Preparing for the cable installation .....	50
6.4 Cable installation .....	51
6.4.1 Enclosure sizes MR8 and MR9 .....	51
6.4.2 Enclosure sizes MR10 and MR12 .....	55

<b>7</b>	<b>Control unit</b> .....	<b>64</b>
7.1	Control unit components .....	64
7.2	Control unit cabling .....	65
7.2.1	Selection of the control cables .....	65
7.2.2	Control terminals and DIP switches .....	66
7.3	Fieldbus connection .....	70
7.3.1	Using fieldbus through an Ethernet cable .....	71
7.3.2	Using fieldbus through an RS485 cable .....	72
7.4	Installation of option boards .....	75
7.4.1	The installation procedure .....	76
7.5	Installation of a battery for the Real Time Clock (RTC) .....	77
7.6	Galvanic isolation barriers .....	77
<b>8</b>	<b>Commissioning and additional instructions</b> .....	<b>79</b>
8.1	Commissioning safety .....	79
8.2	Operation of the motor .....	80
8.2.1	Checks before starting the motor .....	80
8.3	Measuring the cable and motor insulation .....	80
8.4	Installation in an IT system .....	80
8.4.1	The EMC jumper in MR8 .....	81
8.4.2	The EMC jumper in MR9 .....	82
8.4.3	The EMC jumper in MR10 and MR12 .....	83
8.5	Maintenance .....	86
8.5.1	Maintenance intervals .....	86
8.5.2	Replacing the fans of the AC drive .....	87
8.5.3	Downloading the software .....	91
<b>9</b>	<b>Technical data, Vacon® 100</b> .....	<b>95</b>
9.1	AC drive power ratings .....	95
9.1.1	Mains voltage 208-240 V .....	95
9.1.2	Mains voltage 380-500 V .....	96
9.1.3	Mains voltage 525-690 V .....	97
9.1.4	Overload capability .....	97
9.1.5	Brake resistor ratings .....	98
9.2	Vacon® 100 - technical data .....	102
<b>10</b>	<b>Technical data, Vacon® 100 FLOW</b> .....	<b>107</b>
10.1	AC drive power ratings .....	107
10.1.1	Mains voltage 208-240 V .....	107
10.1.2	Mains voltage 380-500 V .....	108
10.1.3	Mains voltage 525-690 V .....	109
10.1.4	Overload capability .....	109
10.2	Vacon® 100 FLOW - technical data .....	111
<b>11</b>	<b>Technical data on control connections</b> .....	<b>116</b>
11.1	Technical data on control connections .....	116

# 1 APPROVALS

Here are the approvals that have been granted to this Vacon product.

Find the EC Declaration of Conformity on the next page.

# VACON®

## EC DECLARATION OF CONFORMITY

We

**Manufacturer's name:** Vacon Oyj  
**Manufacturer's address:** P.O. Box 25  
 Runsorintie 7  
 FIN-65381 Vaasa  
 Finland

hereby declare that the product

**Product name:** Vacon 100 AC drive  
**Model Designation:** **Wall-Mounted Drives:**  
 Vacon 0100 3L 0003 2...0310 2  
 Vacon 0100 3L 0003 4...0310 4  
 Vacon 0100 3L 0003 5...0310 5  
 Vacon 0100 3L 0004 6...0208 6  
 Vacon 0100 3L 0007 7...0208 7  
**IP00 Drive Modules:**  
 Vacon 0100 3L 0140 2...0310 2  
 Vacon 0100 3L 0140 5...1180 5  
 Vacon 0100 3L 0080 7...0820 7  
**Enclosed Drives:**  
 Vacon 0100 3L 0140 5...1180 5  
 Vacon 0100 3L 0080 7...0820 7

has been designed and manufactured in accordance with the following standards:

**Safety:** EN 61800-5-1: 2007  
 EN 60204-1: 2006 + A1: 2009 (as relevant)  
**EMC:** EN 61800-3: 2004 + A1: 2012  
 EN 61000-3-12: 2011

and conforms to the relevant safety provisions of the Low Voltage Directive (2006/95/EC) and EMC Directive 2004/108/EC.

It is ensured through internal measures and quality control that the product conforms at all times to the requirements of the current Directive and the relevant standards.

In Vaasa, 11th of January, 2016



Vesa Laisi  
 President

The year the CE marking was affixed: 2009





## 2 SAFETY

### 2.1 THE SAFETY SYMBOLS USED IN THE MANUAL

This manual contains warnings and cautions, which are identified with safety symbols. The warnings and cautions give important information on how to prevent injury and damage to the equipment or your system.

Read the warnings and cautions carefully and obey their instructions.

**Table 1: The safety symbols**

The safety symbol	Description
	WARNING!
	CAUTION!
	HOT SURFACE!

### 2.2 WARNING



#### WARNING!

Do not touch the components of the power unit when the drive is connected to mains. The components are live when the drive is connected to mains. A contact with this voltage is very dangerous.



#### WARNING!

Do not touch the motor cable terminals U, V, W, the brake resistor terminals or the DC terminals when the drive is connected to mains. These terminals are live when the drive is connected to mains, also when the motor does not operate.



#### WARNING!

Do not touch the control terminals. They can have a dangerous voltage also when the drive is disconnected from mains.

**WARNING!**

Before you do electrical work, make sure that there is no voltage in the components of the drive.

**WARNING!**

To do work on the terminal connections of the drive, disconnect the drive from mains and make sure that the motor has stopped. Wait 5 minutes before you open the cabinet door or the cover of the drive. Then use a measuring device to make sure that there is no voltage. The terminal connections and the components of the drive are live 5 minutes after it is disconnected from mains and the motor has stopped.

**WARNING!**

Before you connect the drive to mains, make sure that the front cover and the cable cover of the drive are closed. The connections of the AC drive are live when the drive is connected to mains.

**WARNING!**

Disconnect the motor from the drive if an accidental start can be dangerous. When there is a power-up, a power break or a fault reset, the motor starts immediately if the start signal is active, unless the pulse control for Start/Stop logic is selected. If the parameters, the applications or the software change, the I/O functions (including the start inputs) can change.

**WARNING!**

Wear protective gloves when you do mounting, cabling or maintenance operations. There can be sharp edges in the AC drive that can cause cuts.

**2.3 CAUTION****CAUTION!**

Do not move the AC drive. Use a fixed installation to prevent damage to the drive.

**CAUTION!**

Do not make measurements when the AC drive is connected to mains. It can cause damage to the drive.

**CAUTION!**

Make sure that there is reinforced protective ground connection. It is mandatory, because the touch current of the AC drives is more than 3.5 mA AC (refer to EN 61800-5-1). See chapter 2.4 *Grounding and earth fault protection*.

**CAUTION!**

Do not use spare parts that are not from the manufacturer. Using other spare parts can cause damage to the drive.

**CAUTION!**

Do not touch the components on the circuit boards. Static voltage can cause damage to these components.

**CAUTION!**

Make sure that the EMC level of the AC drive is correct for your mains. See chapter 8.4 *Installation in an IT system*. An incorrect EMC level can cause damage to the drive.

**CAUTION!**

Prevent radio interference. The AC drive can cause radio interference in a domestic environment.

**NOTE!**

If you activate the autoreset function, the motor starts automatically after an automatic fault reset. See the Application Manual.

**NOTE!**

If you use the AC drive as a part of a machine, the machine manufacturer must supply a mains disconnection device (refer to EN 60204-1).

## 2.4 GROUNDING AND EARTH FAULT PROTECTION

**CAUTION!**

The AC drive must always be grounded with a grounding conductor that is connected to the grounding terminal that is identified with the symbol  $\oplus$ . Not using a grounding conductor can cause damage to the drive.

The touch current of the drive is more than 3.5 mA AC. The standard EN 61800-5-1 tells that 1 or more of these conditions for the protective circuit must be true.

### The connection must be fixed.

- a) The protective grounding conductor must have a cross-sectional area of minimum 10 mm<sup>2</sup> Cu or 16 mm<sup>2</sup> Al. OR
- b) There must be an automatic disconnection of the mains, if the protective grounding conductor breaks. See chapter 6 *Power cabling*. OR
- c) There must be a terminal for a second protective grounding conductor in the same cross-sectional area as the first protective grounding conductor.

**Table 2: Protective grounding conductor cross-section**

Cross-sectional area of the phase conductors (S) [mm <sup>2</sup> ]	The minimum cross-sectional area of the protective grounding conductor in question [mm <sup>2</sup> ]
$S \leq 16$	S
$16 < S \leq 35$	16
$35 < S$	S/2

The values of the table are valid only if the protective grounding conductor is made of the same metal as the phase conductors. If this is not so, the cross-sectional area of the protective grounding conductor must be determined in a manner that produces a conductance equivalent to that which results from the application of this table.

The cross-sectional area of each protective grounding conductor that is not a part of the mains cable or the cable enclosure, must be a minimum of:

- 2.5 mm<sup>2</sup> if there is mechanical protection, and
- 4 mm<sup>2</sup> if there is not mechanical protection. If you have cord-connected equipment, make sure that the protective grounding conductor in the cord is the last conductor to be interrupted, if the strain-relief mechanism breaks.

Obey the local regulations on the minimum size of the protective grounding conductor.

**NOTE!**

Because there are high capacitive currents in the AC drive, it is possible that the fault current protective switches do not operate correctly.

**CAUTION!**

Do not do voltage withstand tests on the AC drive. The manufacturer has already done the tests. Doing voltage withstand tests can cause damage to the drive.

## 2.5 USING AN RCD OR AN RCM DEVICE

The drive can cause a current in the protective grounding conductor. You can use a residual current-operated protective (RCD) device, or a residual current-operated monitoring (RCM) device to give protection against a direct or an indirect contact. Use a type B RCD or RCM device on the mains side of the drive.

**NOTE!** You can download the English and French product manuals with applicable safety, warning and caution information from <http://drives.danfoss.com/knowledge-center/technical-documentation/>.

**REMARQUE** Vous pouvez télécharger les versions anglaise et française des manuels produit contenant l'ensemble des informations de sécurité, avertissements et mises en garde applicables sur le site <http://drives.danfoss.com/knowledge-center/technical-documentation/>.

### 3 RECEIVING THE DELIVERY

Before a Vacon® AC drive is sent to the customer, the manufacturer makes many tests on the drive. However, after you remove the packaging, examine the drive for transport damages.

If the drive was damaged during the shipping, speak to the cargo insurance company or the carrier.

To make sure that the contents of the delivery is correct and complete, compare the type designation of the product to the type designation code. See Chapter 3.2 *Type designation code*.

#### 3.1 PACKAGE LABEL

To make sure that the delivery is correct, compare your order data to the data on the package label. If the delivery does not agree with your order, speak to the vendor immediately.



Fig. 2: The package label of Vacon AC drives

- |                              |                                     |
|------------------------------|-------------------------------------|
| A. The batch ID              | F. The nominal output current       |
| B. The order number of Vacon | G. The IP class                     |
| C. The type designation code | H. The application code             |
| D. The serial number         | I. The order number of the customer |
| E. The mains voltage         |                                     |

### 3.2 TYPE DESIGNATION CODE

The type designation code of Vacon is made of standard codes and option codes. Each part of the type designation code agrees to the data in your order. The code can have this format, for example:

VACON0100-3L-0385-5-FLOW+IP00

**Table 3: The description of the parts in the type designation code**

Code	Description
VACON0100	The product family: VACON0100 = the Vacon 100 product family
3L	Input/Function: 3L = A 3-phase input
0385	The drive rating in amperes. For example, 0385 = 385 A
5	The mains voltage: 2 = 208-240 V 5 = 380-500 V 7 = 525-690 V
FLOW	The product: (empty) = The Vacon 100 INDUSTRIAL AC drive FLOW = The Vacon 100 FLOW AC drive
+IP00	The enclosure class of the AC drive is IP00.

### 3.3 THE CONTENTS OF THE DELIVERY

#### The contents of the delivery, MR8-MR9

- The IP00 drive module with an integrated control unit
- An accessories bag
- Installation Manual, Application Manual and manuals for the options that you ordered

#### The contents of the delivery, MR10

- The IP00 drive module with an integrated control unit
- An accessories bag
- The options module, if you ordered it with options
- Installation Manual, Application Manual and manuals for the options that you ordered

#### The contents of the delivery, MR12

- The IP00 drive module: 2 power units, 1 of them with an integrated control unit
- An accessories bag
- The options module, if you ordered it with options
- A DC link cable
- A set of optical fibre cables
- Installation Manual, Application Manual and manuals for the options that you ordered

### 3.4 REMOVING THE PACKAGING AND LIFTING THE AC DRIVE

#### 3.4.1 WEIGHT OF THE AC DRIVE

The weights of AC drives of different enclosure sizes are very different. It can be necessary for you to use a lifting device to move the drive from its package.

**Table 4: The weight of the AC drive, MR8-MR12**

Enclosure size or item	Weight [kg]	Weight [lb]
MR8 IP00 drive module	62	137
MR9 IP00 drive module	104	228
MR10 IP00 drive module	205	452
MR10 IP00 drive module and the options module with the brake chopper	252	556
MR10 IP00 drive module and the options module with the brake chopper and the common mode filter	258	569
MR10 IP00 drive module and the options module with the brake chopper, the common mode filter, and the du/dt filter	289	637
MR12 IP00 drive module	410	904
MR12 IP00 drive module and the options module with the brake chopper	504	1111
MR12 IP00 drive module and the options module with the brake chopper and the common mode filter	516	1138
MR12 IP00 drive module and the options module with the brake chopper, the common mode filter, and the du/dt filter	578	1274

#### 3.4.2 LIFTING THE IP00 DRIVE MODULE

The AC drive is delivered horizontally on a wooden pallet. Open the package only when you install the drive. We do not recommend that you keep the drive in storage in the vertical position.

##### LIFTING THE IP00 DRIVE MODULE, MR8 AND MR9

- 1 Remove the drive from the pallet where it was bolted to.
- 2 Use a lifting device that is sufficiently strong for the weight of the drive.
- 3 Put the lifting hooks symmetrically in a minimum of 2 holes.

- 4 The maximum lifting angle is 45 degrees.

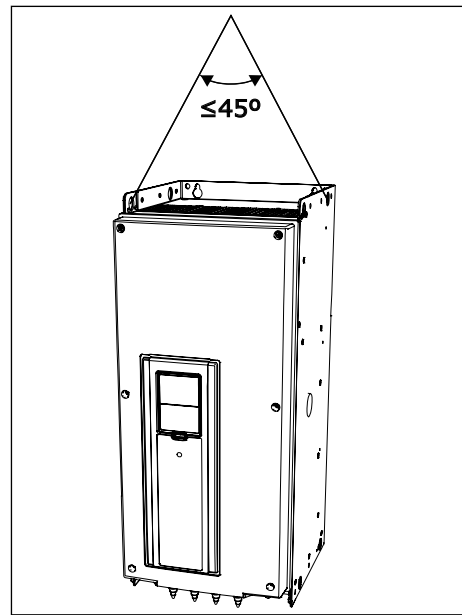



**LIFTING THE IP00 DRIVE MODULE, MR10 OR MR12 WITHOUT THE OPTIONS MODULE**

- 1 Make sure that the support is attached to the bottom of the drive. It gives the terminals protection when you lift the drive or put it vertically on the floor.

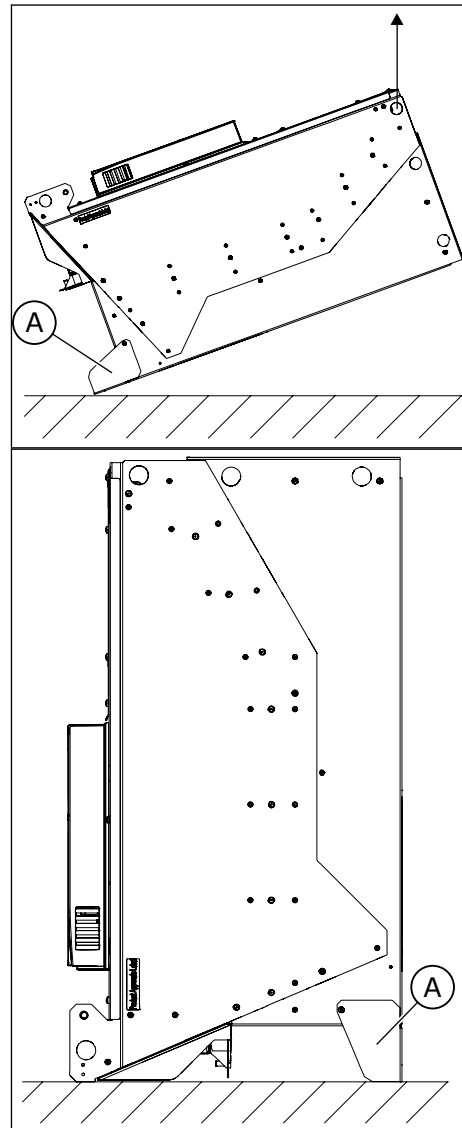

A. The support / fixing bracket

- 2 Lift the drive with a lifting device. Put the lifting hooks in the holes on the top of the cabinet. The maximum lifting angle is 60 degrees.
- 3 After the lifting, you can remove the support if necessary. You can also use it as a fixing bracket.

**LIFTING THE IP00 DRIVE MODULE, MR10 OR MR12 WITH AN OPTIONS MODULE**

- 1 Remove the drive from the package.
- 2 Use a lifting device that is sufficiently strong for the weight of the drive.
- 3 Put the lifting hooks in the holes on the top of the cabinet.

4 Lift the drive into a vertical position.

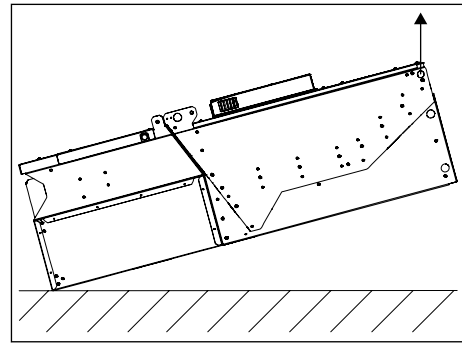

5 The maximum lifting angle is 60 degrees.

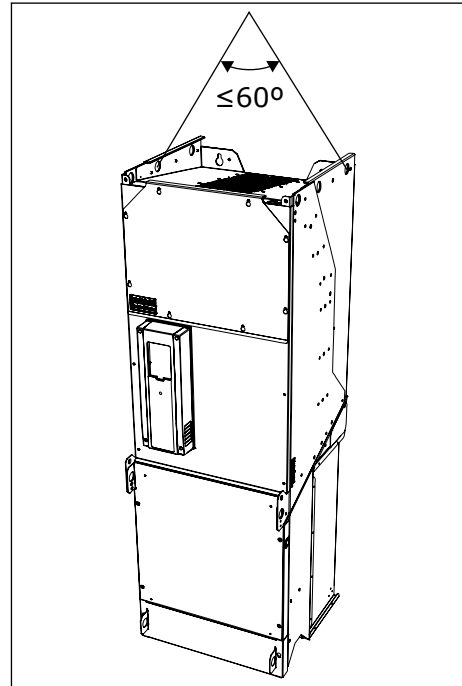

### 3.5 "PRODUCT MODIFIED" LABEL

In the accessories bag, there is also a "product modified" label. The function of the label is to tell the service personnel about the changes that are made in the AC drive. Attach the label on the side of the AC drive to know where to find it. If you make changes in the AC drive, write the change on the label.

<div style="border: 1px solid black; border-radius: 10px; padding: 5px; margin: 0 auto; width: 80%;"> <p style="text-align: center; margin: 0;"><b>Product modified</b></p> <p style="margin: 0;">..... Date: .....</p> <p style="margin: 0;">..... Date: .....</p> <p style="margin: 0;">..... Date: .....</p> </div>
--

### 3.6 DISPOSAL

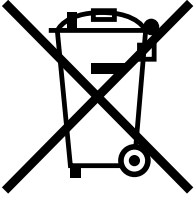
	<p>When the drive is at the end of its operation life, do not discard it as a part of municipal waste. You can recycle the primary components of the drive. You must disassemble some components before you can remove the different materials. Recycle the electrical and electronic components as waste.</p> <p>To make sure that the waste is recycled correctly, send the waste to a recycling centre. You can also send the waste back to the manufacturer.</p> <p>Obey the local and other applicable regulations.</p>
---	--

# 4 MOUNTING DIMENSIONS

## 4.1 DIMENSIONS OF MR8, IP00

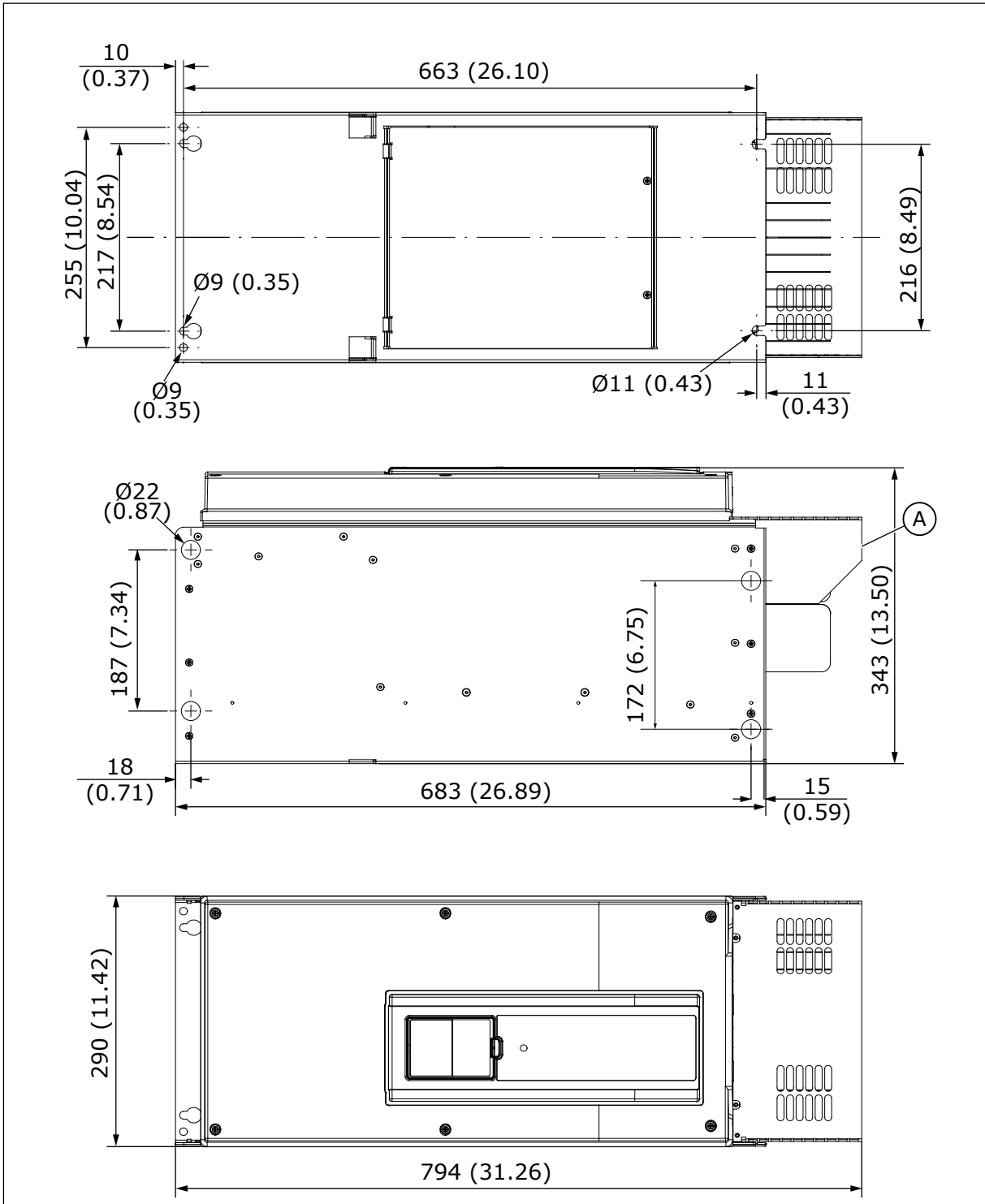

Fig. 3: The dimensions of the AC drive, MR8, [mm [in]]

- A. An optional main connector cover for the cabinet installation

## 4.2 DIMENSIONS OF MR9, IP00

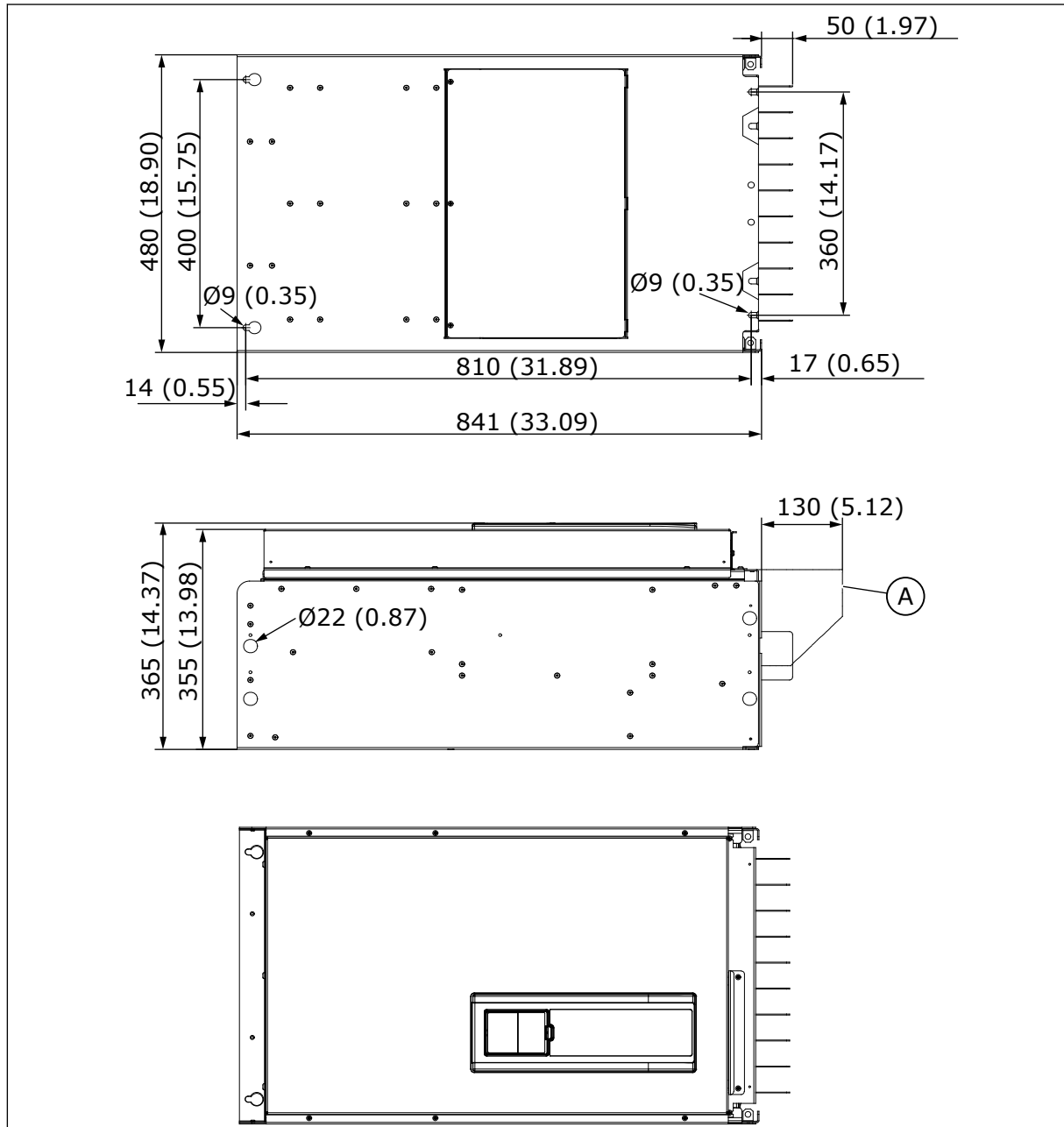

Fig. 4: The dimensions of the AC drive, MR9 [mm (in)]

- A. An optional main connector cover for the cabinet installation

### 4.3 DIMENSIONS OF MR10 AND MR12, IP00

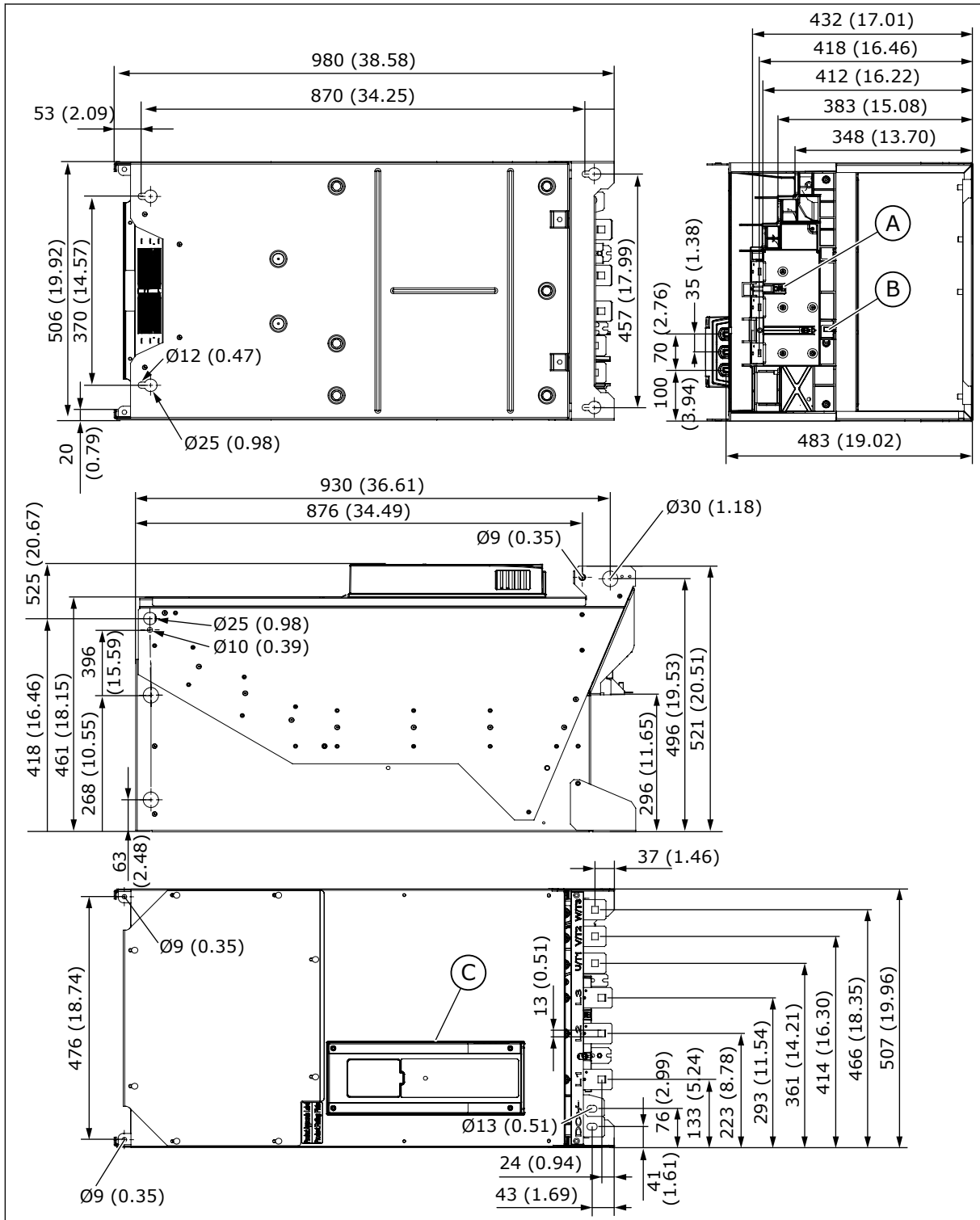

Fig. 5: Dimensions without the options module [mm (in)]

- A. The EMC jumper
- B. M8 GND pin
- C. The control unit



**NOTE!**

The MR12 drive includes 2 power units, and 1 of them includes a control unit.

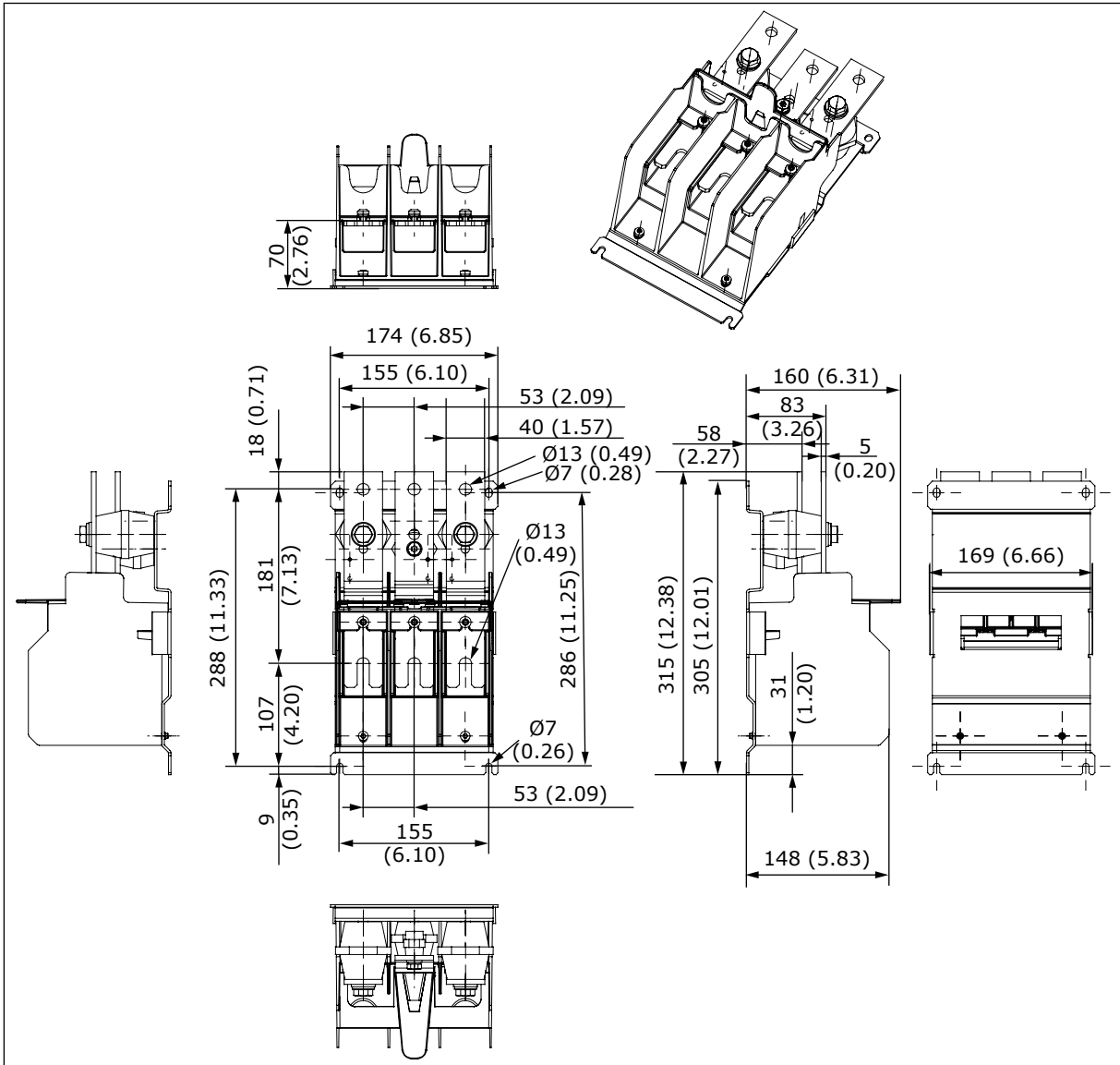

Fig. 6: Dimensions of the optional external power connection block (+PCTB), used without the options module [mm (in)]



**NOTE!**

The optional external power connection block is necessary when the cabling is made with 3 parallel motor cables.

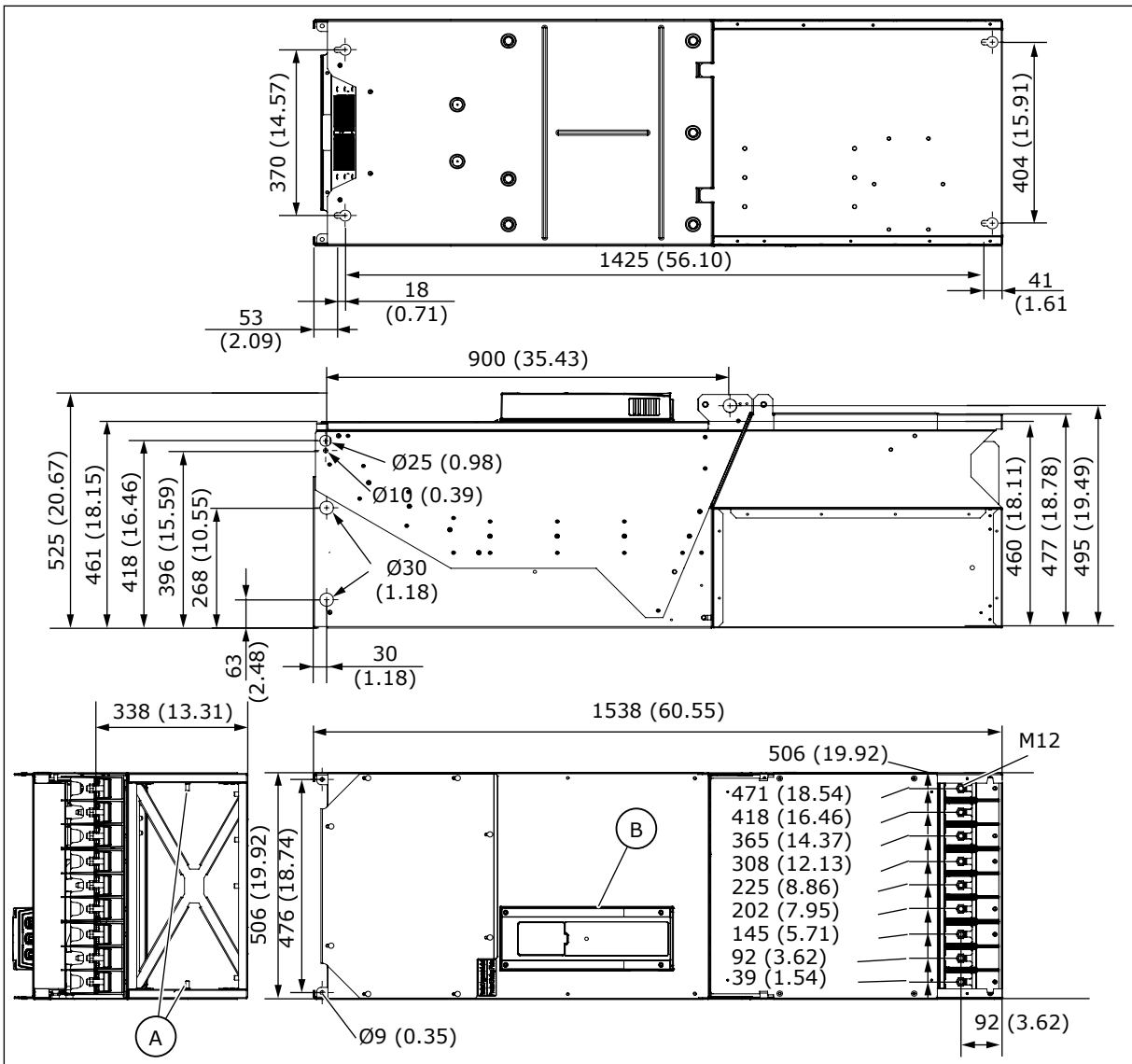

Fig. 7: Dimensions with the options module [mm (in)]

A. M8 GND pins

B. The control unit



# 5 INSTALLATION INTO CABINET

## 5.1 GENERAL INFORMATION

The AC drives that are described in this manual have the enclosure class IP00. You must install them in a cabinet or other enclosure that has a correct level of protection against the ambient conditions in the installation area. Make sure that the cabinet gives protection against water, humidity, dust and other contaminations. The cabinet must also be sufficiently strong for the weight of the IP00 drive module and other devices. When you prepare the installation, obey the local regulations.

### 5.1.1 GENERAL INFORMATION ABOUT THE INSTALLATION, MR8-MR9

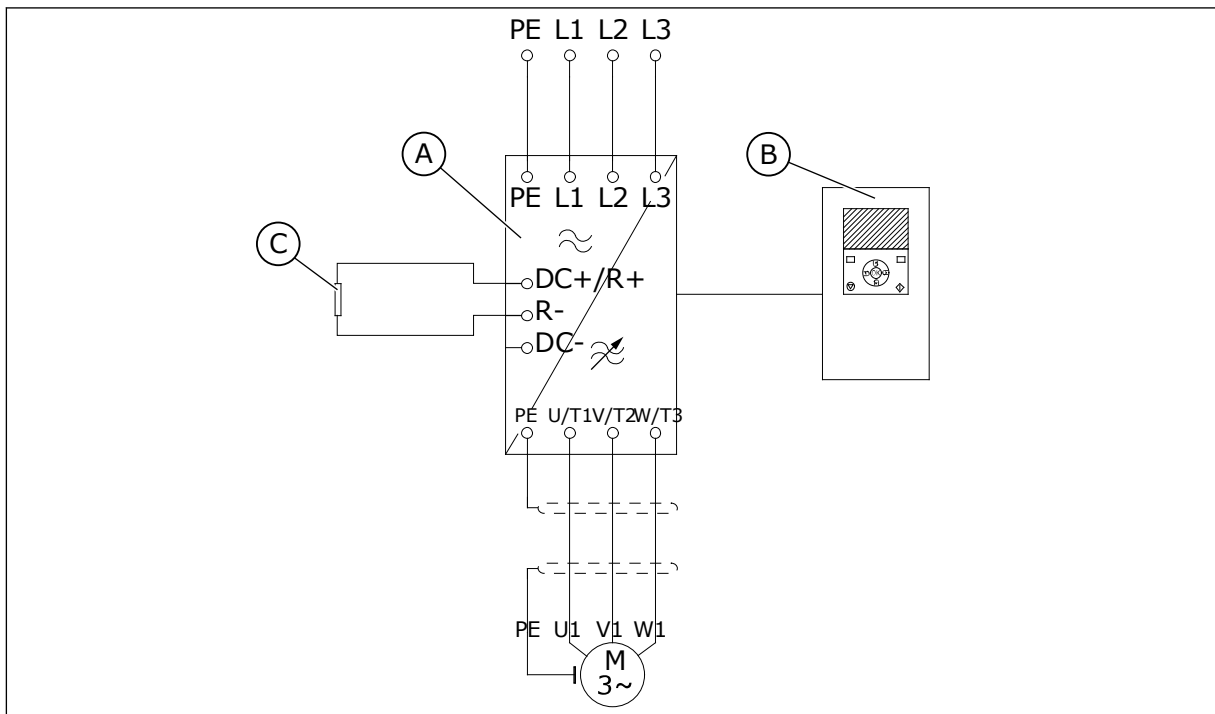

Fig. 8: The main circuit diagram, MR8 and MR9

- A. The power unit
- B. The control unit
- C. The brake resistor for the optional brake chopper

5.1.2 GENERAL INFORMATION ABOUT THE INSTALLATION, MR10

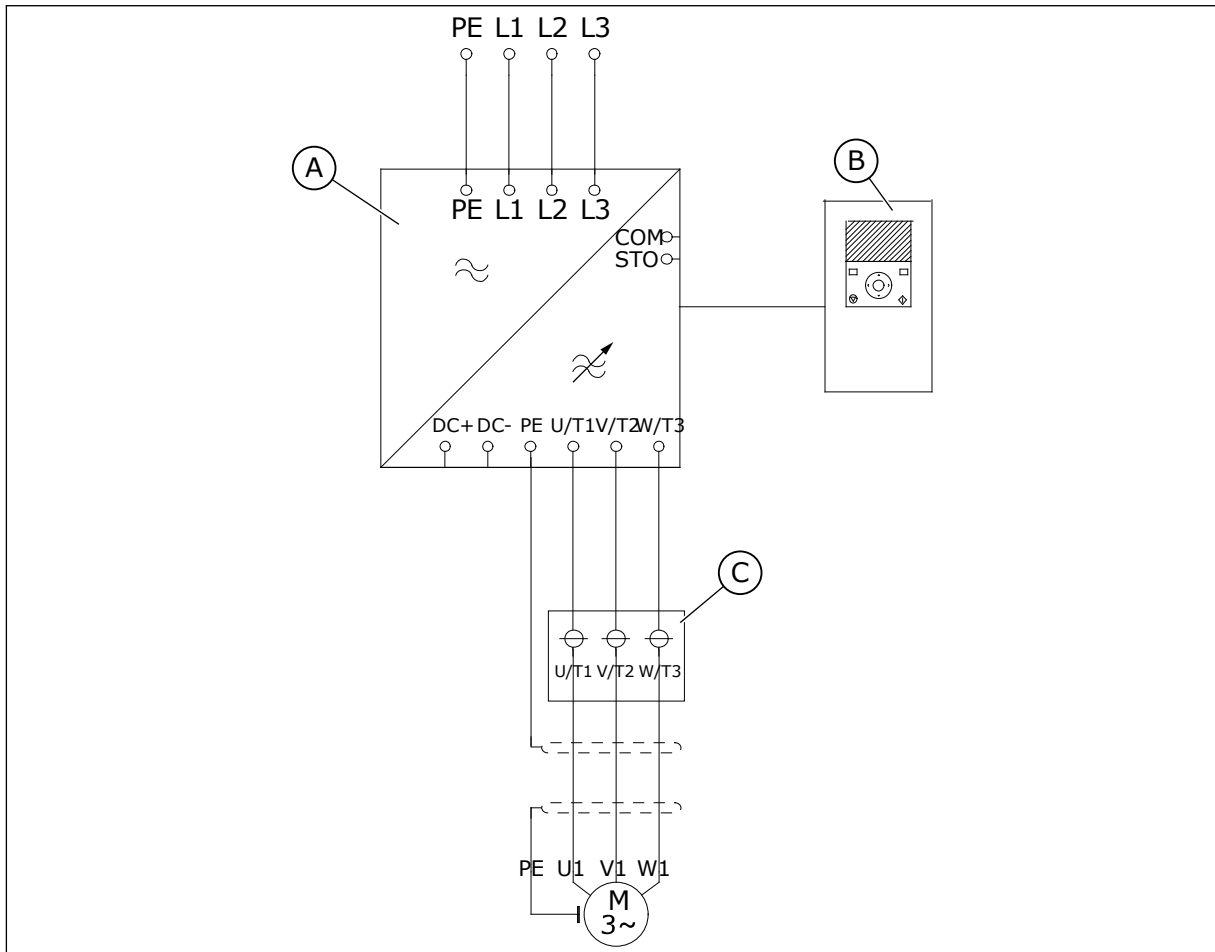

Fig. 9: The main circuit diagram, MR10 without the options module and options

- A. The power unit
- B. The control unit
- C. The optional external power connection block (+PCTB)

The optional external power connection block enables the connection of 3 motor cables to 1 terminal. It is also easier to connect large motor cables when you have this option.

The external power connection block is a loose option, install it near the IP00 drive module. The cables between the motor cable terminals of the drive and the external power connection block are not included in the delivery.



**NOTE!**

The optional external power connection block is not necessary if you have an options module.

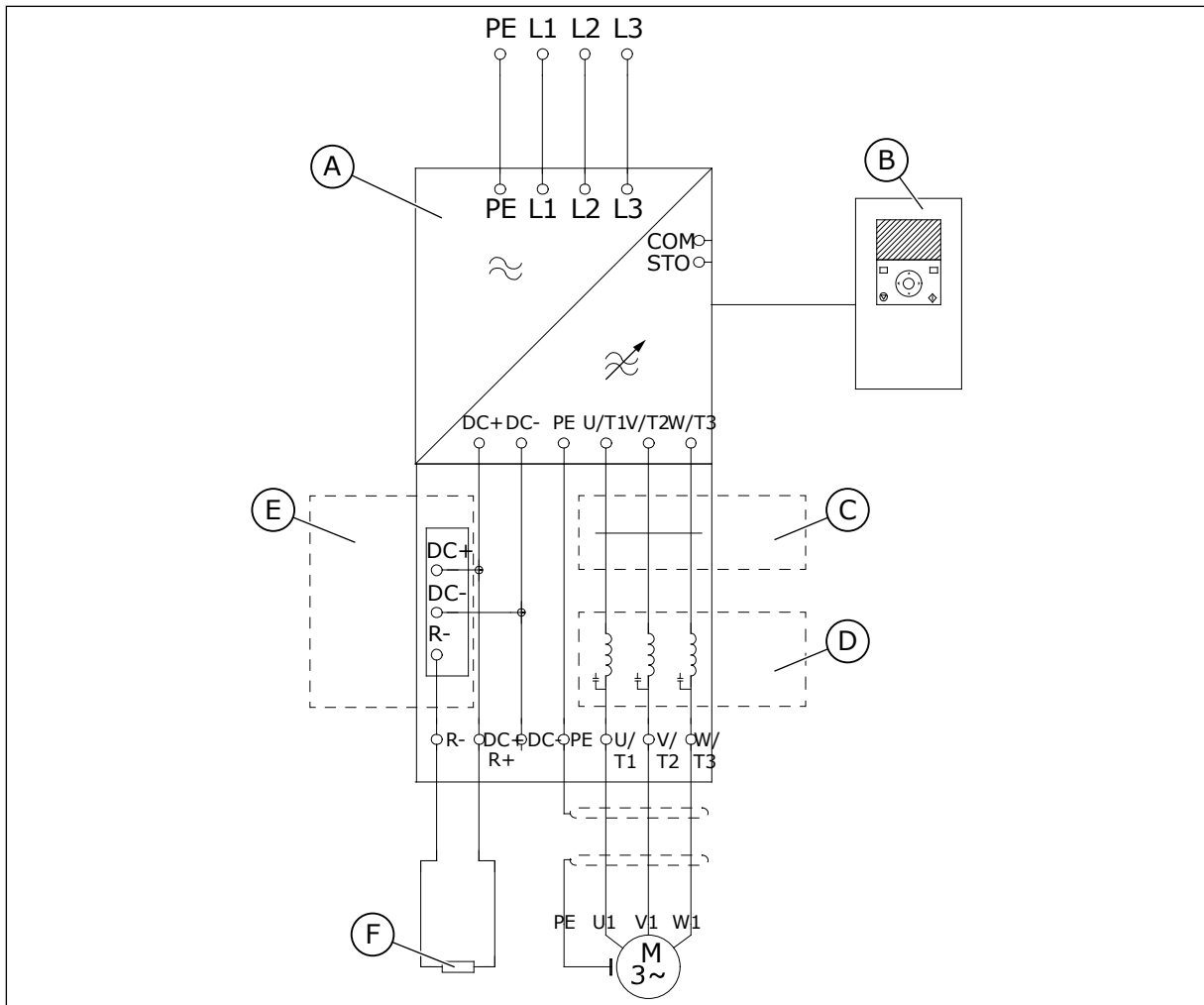

Fig. 10: The main circuit diagram, MR10 with the options module and options

- A. The power unit
- B. The control unit
- C. The optional common mode filter
- D. The optional du/dt filter
- E. The optional brake chopper
- F. The brake resistor



**NOTE!**

The common mode filter is only used as an additional protection. The basic protection against motor bearing currents is an insulated bearing.

**Table 5: The options for MR10**

Option	Order code	Location	Description
The brake chopper	+DBIN	The options module	Enables dynamic braking with an external brake resistor.
The common mode filter	+POCM	The options module	Decreases motor bearing currents.
The du/dt filter	+PODU	The options module	Decreases motor bearing currents and the stress on the motor insulation.
The external power connection block	+PCTB	The cabinet	Enables a more flexible connection of motor cables. A loose option.

**NOTE!**

When your AC drive has the options module, more space is necessary for the installation of the drive.

5.1.3 GENERAL INFORMATION ABOUT THE INSTALLATION, MR12

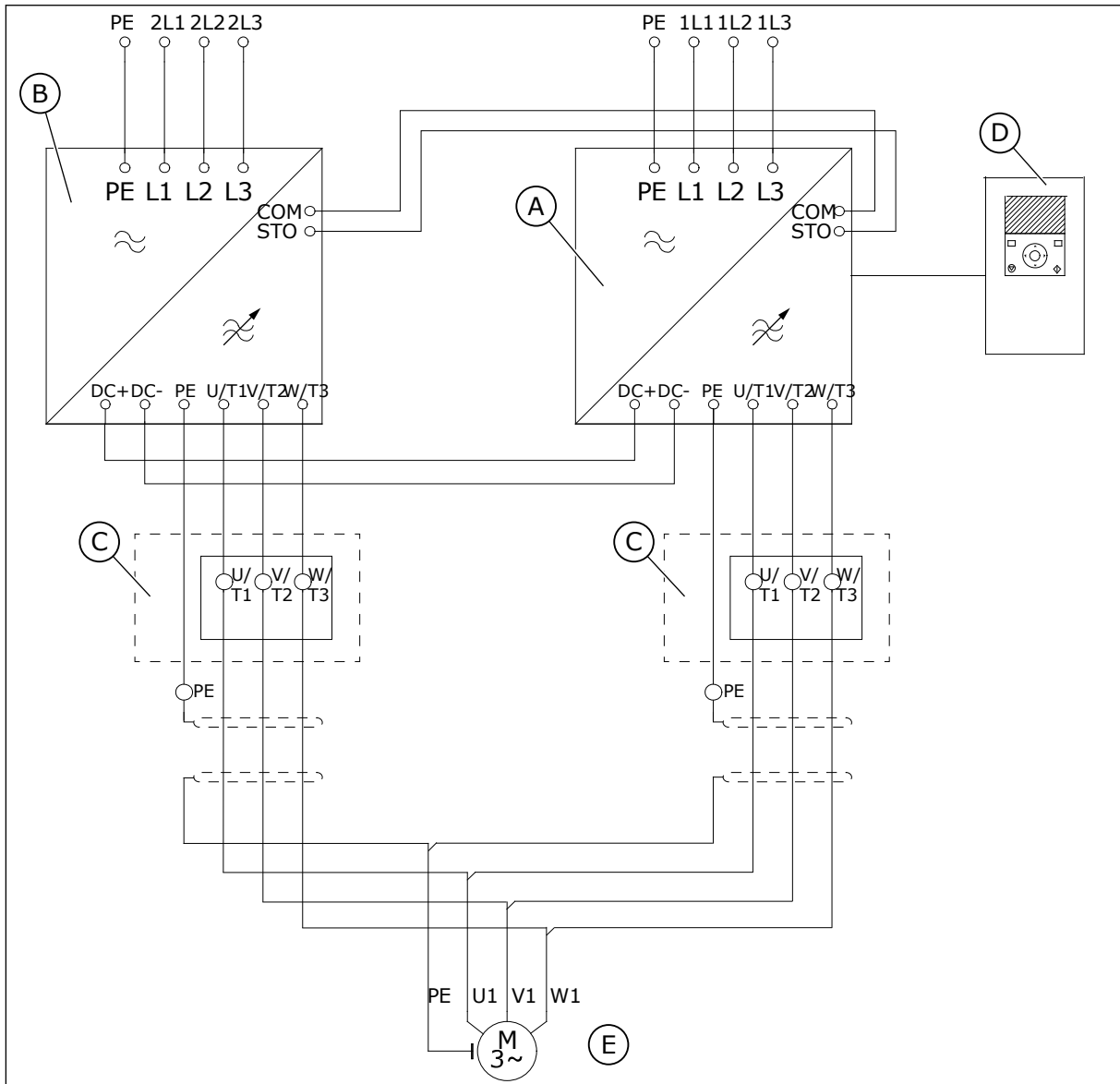

Fig. 11: The main circuit diagram, MR12 without the options module and options

- A. The power unit 1
- B. The power unit 2
- C. The optional external power connection blocks (+PCTB)
- D. The control unit
- E. Symmetrical motor cabling. The cables must have the same length from the power unit to a common point of coupling.

The minimum length of motor cables from the power unit to a common point of coupling is 10 m. When a du/dt filter is used, the cables can be less than 10 m long.

The optional external power connection block enables the connection of 3 motor cables to 1 terminal. It is also easier to connect large motor cables when you have this option.

The external power connection block is a loose option, install it near the IP00 drive module. The cables between the motor cable terminals of the drive and the external power connection block are not included in the delivery.



**NOTE!**

The optional external power connection block is not necessary if you have an options module.

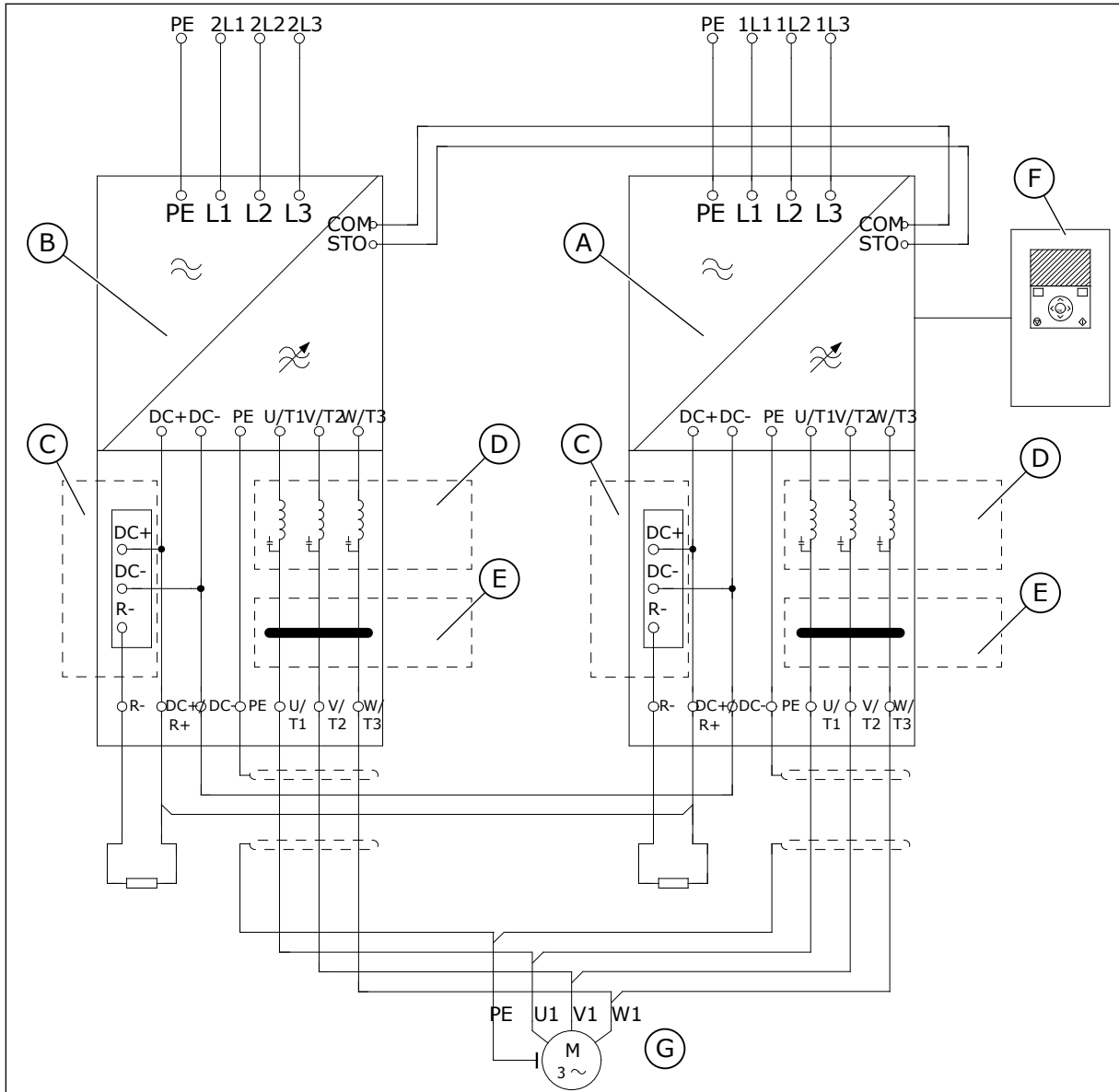

Fig. 12: The main circuit diagram, MR12 with the options module and options

- A. The power unit 1
- B. The power unit 2
- C. The optional brake choppers
- D. The optional common mode filter
- E. The optional du/dt filter
- F. The control unit
- G. Symmetrical motor cabling. The cables must have the same length from the power unit to a common point of coupling.

**Table 6: The options for MR12**

Option	Order code	Location	Description
The brake chopper	+DBIN	The options module	Enables dynamic braking with an external brake resistor.
The common mode filter	+POCM	The options module	Decreases motor bearing currents.
The du/dt filter	+PODU	The options module	Decreases motor bearing currents and the stress on the motor insulation.
The external power connection block	+PCTB	The cabinet	Enables a more flexible connection of motor cables. A loose option.



**NOTE!**

When your AC drive has the options module, more space is necessary for the installation of the drive.

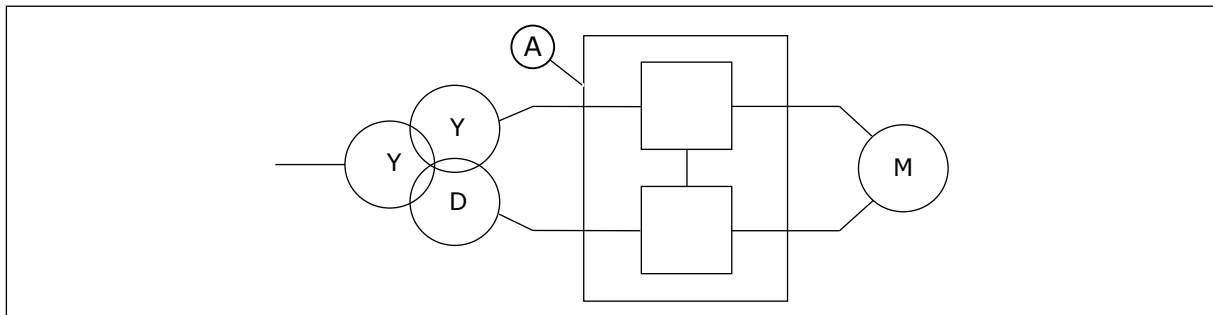

*Fig. 13: The 12-pulse operation of MR12*

A. The MR12 drive

With MR12 you can also use a 12-pulse connection to reduce the harmonics level in the supply side of the drive. In the 12-pulse connection, the parallel drives are cabled to the transformer's secondary windings that have a 30-degree phase shift.

**5.2 MECHANICAL INSTALLATION**

Install the AC drive in a vertical position at the rear plane of the cabinet. We recommend that you attach rails on the sides inside the cabinet. The rails make the drive more stable and the servicing easier.

## 5.2.1 INSTALLING THE IP00 DRIVE MODULE INTO THE CABINET

### INSTALLING THE IP00 DRIVE MODULE WITHOUT THE OPTIONS MODULE

- 1 We recommend that you install the IP00 drive module on rails inside the cabinet.

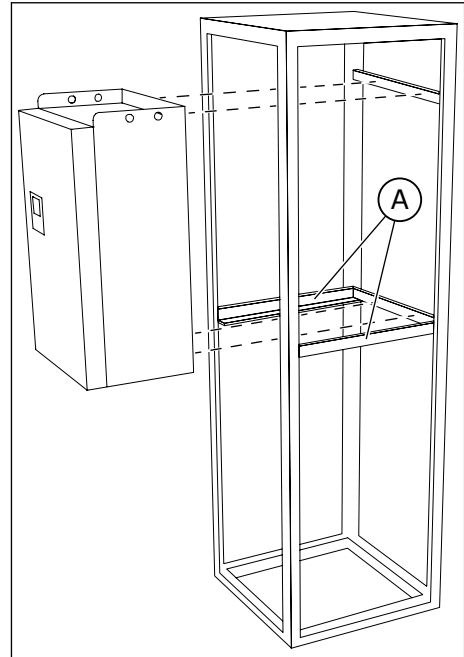

A. The rails inside the cabinet

- 2 Use fixing points to attach the IP00 drive module into the cabinet. See the locations of the fixing points in Chapter 4 *Mounting dimensions*.

### INSTALLING THE MR10 OR MR12 IP00 DRIVE MODULE WITH AN OPTIONS MODULE

Here you can see a recommended installation of the IP00 drive module with an options module into the cabinet.



- 1 Use the fixing points at the front of the drive.

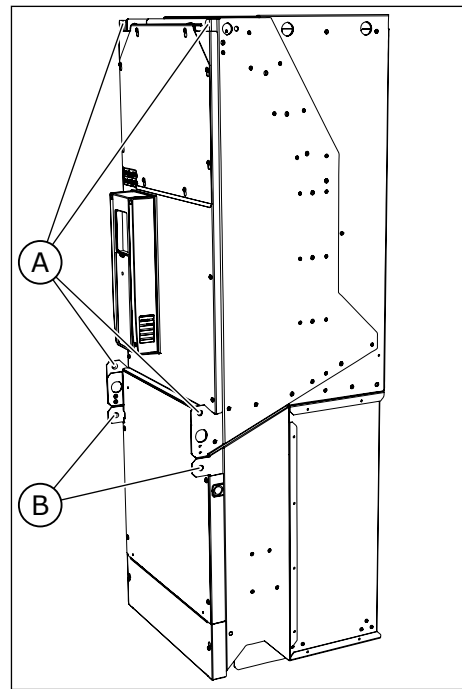

- A. The front fixing points
- B. The fixing points of the options module. These are important for a safe maintenance if the IP00 drive module is removed.

- 2 Use the fixing points at the rear of the drive.

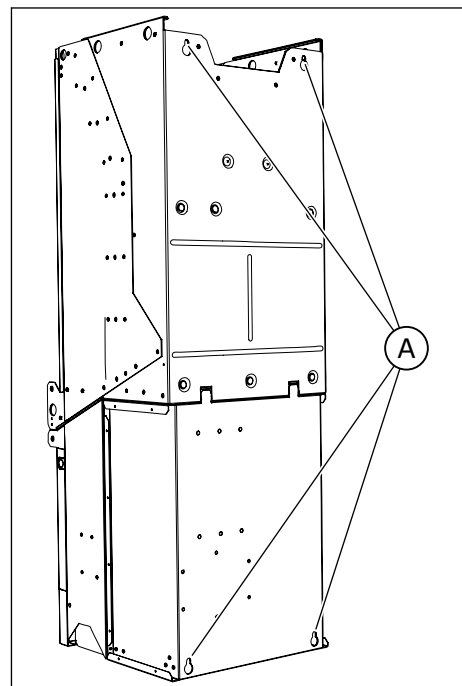

- A. The rear fixing points

## 5.2.2 COOLING AND FREE SPACE AROUND THE AC DRIVE

The AC drive produces heat in operation. The fan circulates air and decreases the temperature of the drive. Make sure that there is sufficiently free space around the drive.

Some free space in front of the drive is also necessary for maintenance. You must be able to open the cabinet door. When you have 2 or more drives, you can install them side by side.

Make sure that the temperature of the cooling air does not become higher than the maximum ambient operating temperature or lower than the minimum ambient operating temperature of the drive.

The air must move freely and efficiently through the cabinet and the drive. There must be a minimum of 20 cm (7.87 in) of space above the drive without obstacles that can stop the airflow. Make sure that the hot air goes out of the cabinet and does not come back into the cabinet.

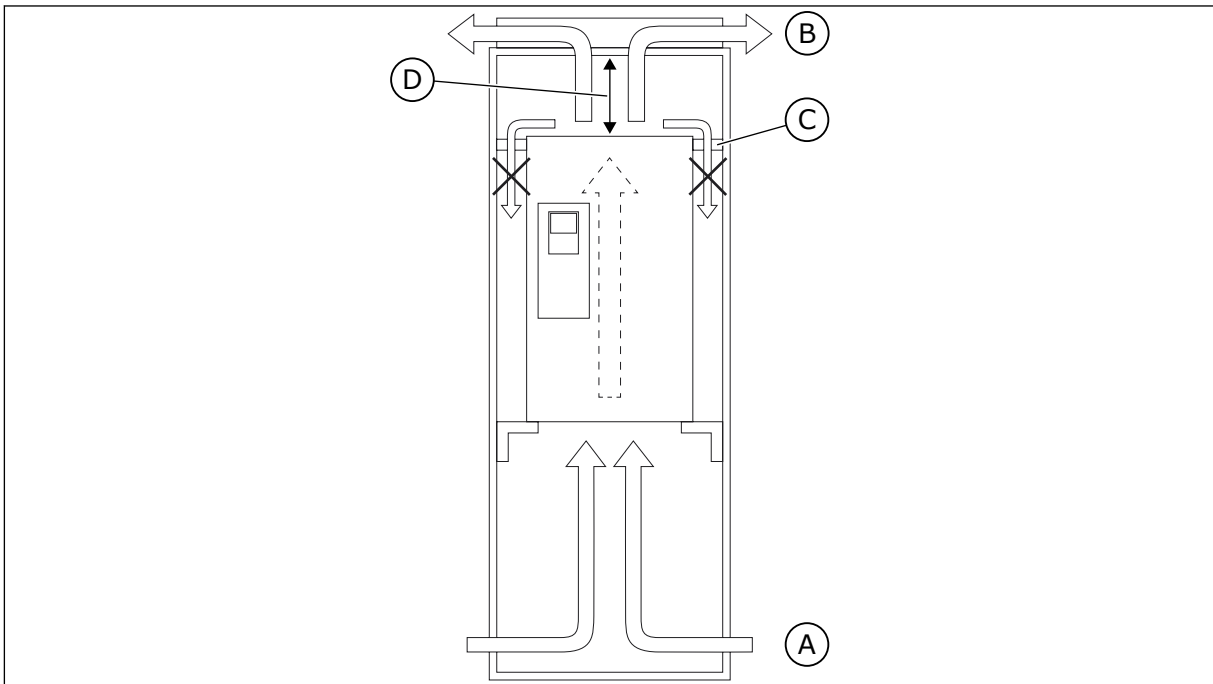

Fig. 14: The correct circulation of cooling air inside the cabinet

- A. Cool air going in
- B. Hot air coming out
- C. Install shields to prevent recirculation of hot air inside the cabinet.
- D. Minimum 200 mm (7.87 in)

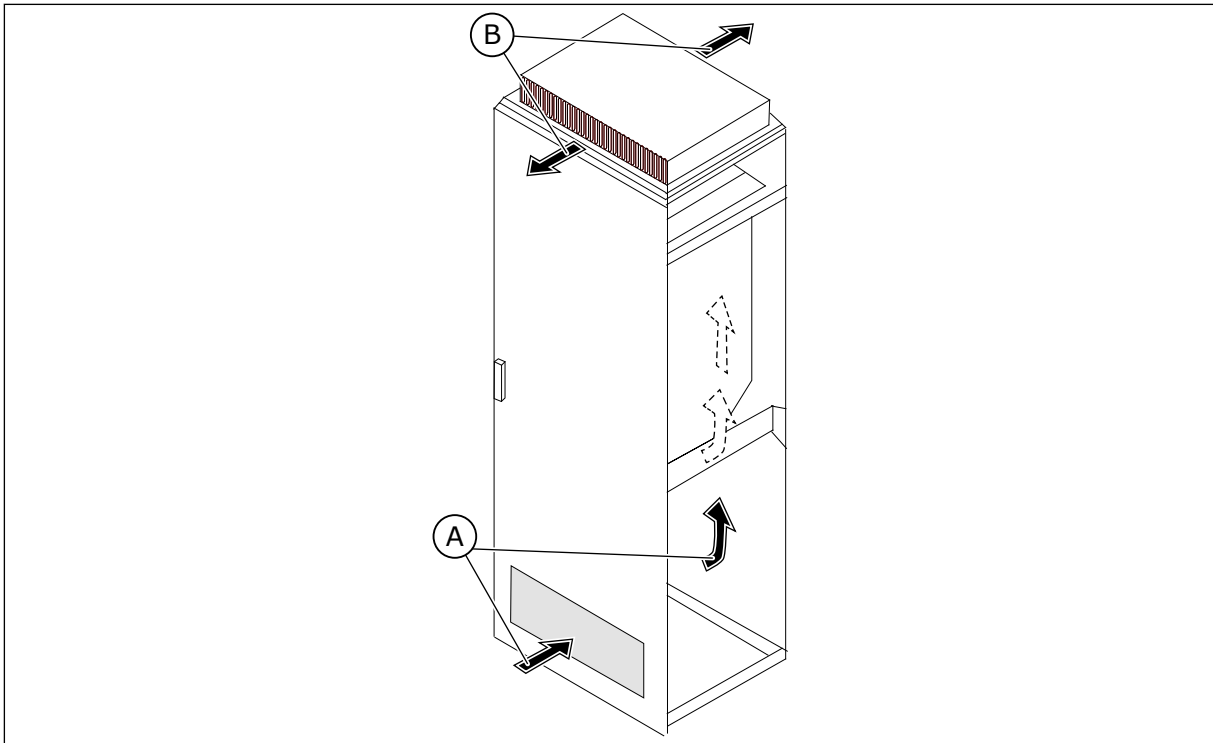

Fig. 15: The cooling air must move freely inside the cabinet

A. Cool air going in

B. Hot air coming out

**Table 7: The necessary quantity of cooling air**

Enclosure size	The quantity of cooling air [m <sup>3</sup> /h]	The quantity of cooling air [CFM]	The surface area of the air intake holes [cm <sup>2</sup> ] *	The surface area of the air intake holes [in <sup>2</sup> ] *
MR8	330	194	150	23.25
MR9	620	365	300	46.50
MR10	1400	824	600	93.00
MR12	2 x 1400	2 x 824	2 x 600	2 x 93.00

\* = The surface area is the total area of the openings, not the surface area of, for example, a grill.

This quantity of cooling air is sufficient for the AC drive. If you have other devices that cause power losses inside the cabinet, or if you use more filters (for example to have a higher level of protection), you must increase the surface area of the air intake holes.

## 6 POWER CABLING

### 6.1 CABLE DIMENSIONING AND SELECTION

#### 6.1.1 CABLE AND FUSE SIZES

We recommend the fuse type gG/gL (IEC 60269-1) for mains fuses (-F1). Use only fuses that have a sufficient voltage rating according to the mains voltage. Do not use larger fuses than what is recommended in *Table 8*. The fuses are selected for short circuit protection only.



#### NOTE!

The overcurrent protection of parallel cables must be done with separate fuses.

Make sure that the operation time of the fuse is less than 0.4 seconds. The operation time agrees with the fuse type and the impedance of the supply circuit.

The drive must be protected with fast acting aR-type fuses (-FC1) (see *Table 10* and *Table 12*). Do not use other fuses than these.

No fuses are included in the delivery (-F1 or -FC1).

The table also shows the typical symmetrically shielded copper and aluminum types of the cables that can be used with the AC drive.



#### NOTE!

The mains cable and fuse sizes are valid up to a cable length of 100 m, with mains  $I_K = 20$  kA.

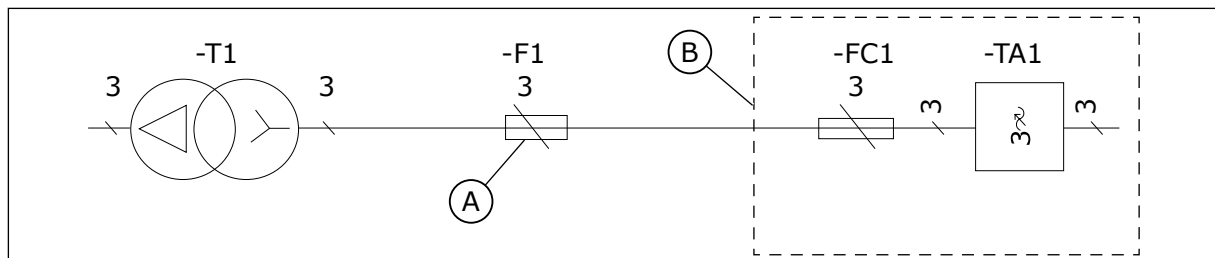

Fig. 16: The location of the fuses

A. The mains fuses

B. The cabinet

#### The dimensions of the cables agree with the requirements of the standards EN 60204-1 and IEC 60364-5-52: 2001.

- The cables are PVC-isolated.
- The maximum ambient temperature is +30 °C.
- The maximum temperature of the cable surface is +70 °C.
- The maximum number of parallel cables on a ladder type tray is 9 side by side.

In other conditions, when you select the dimensions of the cables, refer to local safety regulations, the input voltage and the load current of the drive.

**Table 8: The recommended mains cables and fuses in 208-240 V and 380-500 V**

Enclosure size	Type	IL [A]	Mains fuses per phase (gG/gL) [A]	Mains and motor cable (Cu/Al) [mm <sup>2</sup> ]	Mains cable terminal, bolt size [mm <sup>2</sup> ]	Grounding terminal, bolt size [mm <sup>2</sup> ]
MR8	0140 2 0140 5	140	160	{3x70+35} (Cu) {3x95+29} (Al)	M8	M8
	0170 2 0170 5	170	200	{3x95+50} (Cu) {3x150+41} (Al)	M8	M8
	0205 2 0205 5	205	250	{3x120+70} (Cu) {3x185+57} (Al)	M8	M8
MR9	0261 2 0261 5	261	315	{3x185+95} (Cu) 2x{3x120+41} (Al)	M10	M8
	0310 2 0310 5	310	350	2x{3x95+50} (Cu) 2x{3x120+41} (Al)	M10	M8
MR10	0385 5	385	400	2x{3x120+70} (Cu) 2x{3x185+57} (Al)	M12	M8
	0460 5	460	500	2x{3x185+95} (Cu) 2x{3x240+72} (Al)	M12	M8
	0520 5	520	630	2x{3x185+95} (Cu) 3x{3x150+41} (Al)	M12	M8
	0590 5	590	630	2x{3x240+120} (Cu) 3x{3x185+57} (Al)	M12	M8
MR12	0650 5	650	2 x 355	4x{3x95+50} 4x{3x120+41}	M12	M8
	0730 5	730	2 x 400	4x{3x95+50} 4x{3x150+41}	M12	M8
	0820 5	820	2 x 500	4x{3x120+70} 4x{3x185+57}	M12	M8
	0920 5	920	2 x 500	4x{3x150+70} 4x{3x240+72}	M12	M8
	1040 5	1040	2 x 630	4x{3x185+95} 6x{3x150+41}	M12	M8
	1180 5	1180	2 x 630	4x{3x240+120} 6x{3x185+57}	M12	M8

**Table 9: The recommended mains cables and fuses in 525-690 V**

Enclosure size	Type	IL [A]	Mains fuses per phase (gG/gL) [A]	Mains and motor cable (Cu/Al) [mm <sup>2</sup> ]	Mains cable terminal, bolt size [mm <sup>2</sup> ]	Grounding terminal, bolt size [mm <sup>2</sup> ]
MR8	0080 6 0080 7	80	100	3x35+16 (Cu) 3x50+21 (Al)	M8	M8
	0100 6 0100 7	100	125	3x50+25 (Cu) 3x70+21 (Al)	M8	M8
	0125 6 0125 7	125	160	3x70+35 (Cu) 3x95+29 (Al)	M8	M8
MR9	0144 6 0144 7	144	160	3x70+35 (Cu) 3x120+41 (Al)	M10	M8
	0170 6 0170 7	170	200	3x95+50 (Cu) 3x150+41 (Al)	M10	M8
	0208 6 0208 7	208	250	3x120+70 (Cu) 3x185+57 (Al)	M10	M8
MR10	0261 6 0261 7	261	315	3x185+95 2x(3x95+29)	M12	M8
	0325 6 0325 7	325	355	3x240+120 2x(3x120+41)	M12	M8
	0385 6 0385 7	385	400	2x(3x120+70) 2x(3x185+57)	M12	M8
	0416 6 0416 7	416	450	2x(3x120+70) 2x(3x185+57)	M12	M8
MR12	0460 6 0460 7	460	2 x 315	2x(3x150+70) 2x(3x240+72)	M12	M8
	0520 6 0520 7	520	2 x 315	2x(3x185+95) 4x(3x95+29)	M12	M8
	0590 6 0590 7	590	2 x 315	4x(3x70+35) 4x(3x120+41)	M12	M8
	0650 6 0650 7	650	2 x 355	4x(3x95+50) 4x(3x150+41)	M12	M8
	0750 6 0750 7	750	2 x 400	4x(3x120+70) 4x(3x150+41)	M12	M8
	0820 6 0820 7	820	2 x 425	4x(3x120+70) 4x(3x185+57)	M12	M8

**Table 10: Drive fuses, 208-240 V and 380-500 V, Mersen**

Enclosure size	Type	IL [A]	Catalogue number of the fuse	Fuse rating [A]	Number of fuses needed	Fuse size	Minimum prospective short circuit current
MR8	0140 2 0140 5	140	NH1UD69V250PV	250	3	1	1400
	0170 2 0170 5	170	NH1UD69V350PV	350	3	1	2400
	0205 2 0205 5	205	NH1UD69V400PV	400	3	1	2800
MR9	0261 2 0261 5	261	NH2UD69V500PV	500	3	2	3300
	0310 2 0310 5	310	NH2UD69V630PV	630	3	2	5000
MR10	0385 5	385	NH2UD69V700PV	700	3	2	5700
	0460 5	460	NH3UD69V900PV	900	3	3	7000
	0520 5	520	NH3UD69V1000PV	1000	3	3	8600
	0590 5	590	PC73UD90V10CPA	1000	3	3	13000
MR12	0650 5	650	NH2UD69V630PV	630	6	2	5000
	0730 5	730	NH2UD69V700PV	700	6	2	5700
	0820 5	820	NH3UD69V900PV	900	6	3	7000
	0920 5	920	NH3UD69V1000PV	1000	6	3	8600
	1040 5	1040	NH3UD69V1000PV	1000	6	3	8600
	1180 5	1180	PC73UD90V10CPA	1000	6	3	13000

**Table 11: Drive fuses, 525-690 V, Mersen**

Enclosure size	Type	IL [A]	Catalogue number of the fuse	Fuse rating [A]	Number of fuses needed	Fuse size	Minimum prospective short circuit current
MR8	0080 6 0080 7	80	NH1UD69V125PV	125	3	1	500
	0100 6 0100 7	100	NH1UD69V160PV	160	3	1	700
	0125 6 0125 7	125	NH1UD69V200PV	200	3	1	1000
MR9	0144 6 0144 7	144	NH1UD69V315PV	315	3	1	2000
	0170 6 0170 7	170	NH1UD69V350PV	350	3	1	2400
	0208 6 0208 7	208	NH1UD69V400PV	400	3	1	2800
MR10	0261 6 0261 7	261	NH2UD69V400PV	400	3	2	2800
	0325 6 0325 7	325	NH2UD69V500PV	500	3	2	3300
	0385 6 0385 7	385	NH2UD69V630PV	630	3	2	5000
	0416 6 0416 7	416	NH3UD69V900PV	900	3	3	7100
MR12	0460 6 0460 7	460	NH2UD69V400PV	400	6	2	2400
	0520 6 0520 7	520	NH2UD69V450PV	450	6	2	2800
	0590 6 0590 7	590	NH2UD69V500PV	500	6	2	3300
	0650 6 0650 7	650	NH2UD69V550PV	550	6	3	4000
	0750 6 0750 7	750	NH2UD69V630PV	630	6	2	5000
	0820 6 0820 7	820	NH3UD69V900PV	900	6	3	7100



**Table 12: Drive fuses, 208-240 V and 380-500 V, Bussmann**

Enclosure size	Type	IL [A]	Catalogue number of the fuse	Fuse rating [A]	Number of fuses needed	Fuse size	Minimum prospective short circuit current
MR8	0140 2 0140 5	140	170M3817D	315	3	1	1700
	0170 2 0170 5	170	170M3818D	350	3	1	1950
	0205 2 0205 5	205	170M3819D	400	3	1	2400
MR9	0261 2 0261 5	261	170M5810D	500	3	2	2800
	0310 2 0310 5	310	170M5812D	630	3	2	4000
MR10	0385 5	385	170M5814D	800	3	2	5750
	0460 5	460	170M6814D	1000	3	3	7500
	0520 5	520	170M6892D	1100	3	3	8500
	0590 5	590	170M8554D	1250	3	3	10500
MR12	0650 5	650	170M5814D	800	6	2	5750
	0730 5	730	170M5814D	800	6	2	5750
	0820 5	820	170M6813D	900	6	3	6000
	0920 5	920	170M6814D	1000	6	3	7500
	1040 5	1040	170M6892D	1100	6	3	8500
	1180 5	1180	170M8554D	1250	6	3	10500

**Table 13: Drive fuses, 525-690 V, Bussmann**

Enclosure size	Type	IL [A]	Catalogue number of the fuse	Fuse rating [A]	Number of fuses needed	Fuse size	Minimum prospective short circuit current
MR8	0080 6 0080 7	80	170M3814D	160	3	1	650
	0100 6 0100 7	100	170M3815D	200	3	1	950
	0125 6 0125 7	125	170M3816D	250	3	1	1300
MR9	0144 6 0144 7	144	170M3817D	315	3	1	1700
	0170 6 0170 7	170	170M3819D	400	3	1	2400
	0208 6 0208 7	208	170M4863D	450	3	1	2800
MR10	0261 6 0261 7	261	170M5811D	550	3	2	3400
	0325 6 0325 7	325	170M5813D	700	3	2	4800
	0385 6 0385 7	385	170M5814D	800	3	2	5750
	0416 6 0416 7	416	170M6814D	1000	3	3	7500
MR12	0460 6 0460 7	460	170M5811D	550	6	2	3400
	0520 6 0520 7	520	170M5812D	630	6	2	4000
	0590 6 0590 7	590	170M5813D	700	6	2	4800
	0650 6 0650 7	650	170M5813D	700	6	2	4800
	0750 6 0750 7	750	170M5814D	800	6	2	5750
	0820 6 0820 7	820	170M6813D	900	6	3	6000

### 6.1.2 CABLE AND FUSE SIZES, NORTH AMERICA

We recommend the fuse class T (UL & CSA). To make a selection of the fuse voltage rating, refer to the mains. Refer also to local regulations, cable installation conditions and cable specification. Do not use larger fuses than what is recommended in *Table 14* and *Table 15*.

Make sure that the operation time of the fuse is less than 0.4 seconds. The operation time agrees with the fuse type and the impedance of the supply circuit. For more information on faster fuses, speak to the manufacturer. The manufacturer can also recommend some high speed Class J (UL & CSA ) and aR (UL recognised) fuse ranges.

The solid state short circuit protection does not supply protection for the branch circuit of the AC drive. To supply the branch circuit protection, refer to the National Electric Code and the local regulations. Do not use other devices than fuses to supply branch circuit protection.



#### NOTE!

The Vacon® 100 FLOW and HVAC software do not have the dynamic braking or the brake resistor functions.

#### **The dimensions of the cables must agree with the requirements of the Underwriters Laboratories UL 61800-5-1.**

- The cables must be PVC-isolated.
- The maximum ambient temperature is +86 °F.
- The maximum temperature of the cable surface is +158 °F.
- Use only cables with a concentric copper shield.
- The maximum number of parallel cables is 9.

When you use parallel cables, make sure that you obey the requirements of the cross-sectional area and the maximum number of cables.

For important information on the requirements of the grounding conductor, see the Underwriters Laboratories standard UL 61800-5-1.

For the correction factors for each temperature, see the instructions of the Underwriters Laboratories UL 61800-5-1.

**Table 14: The cable and fuse sizes for Vacon® 100 in North America, mains voltage 208-240 V and 380-500 V**

Enclosure size	Type	IL [A]	Fuse (Class T/J) [A]	Mains and motor cable (Cu) [AWG/kcmil]	Terminal cable size	
					Mains cable terminal [AWG/kcmil]	Grounding terminal [AWG/kcmil]
MR8	0140 2 0140 5	140.0	200	3/0	1 AWG-350 kcmil	1 AWG-350 kcmil
	0170 2 0170 5	170.0	225	250 kcmil	1 AWG-350 kcmil	1 AWG-350 kcmil
	0205 2 0205 5	205.0	250	350 kcmil	1 AWG-350 kcmil	1 AWG-350 kcmil
MR9	0261 2 0261 5	261.0	350	2x250 kcmil	1 AWG-350 kcmil	1 AWG-350 kcmil
	0310 2 0310 5	310.0	400	2x350 kcmil	1 AWG-350 kcmil	1 AWG-350 kcmil
MR10	0385 5	385	500	2x250 kcmil	1 AWG-350 kcmil	1 AWG-350 kcmil
	0460 5	460	600	2x350 kcmil	1 AWG-350 kcmil	1 AWG-350 kcmil
	0520 5	520	700	3x4/0	1 AWG-350 kcmil	1 AWG-350 kcmil
	0590 5	590	800	3x250 kcmil	1 AWG-350 kcmil	1 AWG-350 kcmil
MR12	0650 5	650	2x400	4x4/0	1 AWG-350 kcmil	1 AWG-350 kcmil
	0730 5	730	2x500	4x300	1 AWG-350 kcmil	1 AWG-350 kcmil
	0820 5	820	2x600	4x350	1 AWG-350 kcmil	1 AWG-350 kcmil
	0920 5	920	2x600	6x4/0	1 AWG-350 kcmil	1 AWG-350 kcmil
	1040 5	1040	2x600	6x250	1 AWG-350 kcmil	1 AWG-350 kcmil
	1180 5	1180	2x700	6x300	1 AWG-350 kcmil	1 AWG-350 kcmil

**Table 15: The cable and fuse sizes for Vacon® 100 in North America, mains voltage 525-690 V**

Enclosure size	Type	IL [A]	Fuse (Class T/J) [A]	Mains and motor cable (Cu) [AWG/kcmil]	Terminal cable size	
					Mains cable terminal [AWG/kcmil]	Grounding terminal [AWG/kcmil]
MR8	0080 7	80.0	90	1/0	1 AWG-350 kcmil	1 AWG-350 kcmil
	0100 7	100.0	110	1/0	1 AWG-350 kcmil	1 AWG-350 kcmil
	0125 7	125.0	150	2/0	1 AWG-350 kcmil	1 AWG-350 kcmil
MR9	0144 7	144.0	175	3/0	1 AWG-350 kcmil	1 AWG-350 kcmil
	0170 7	170.0	200	4/0	1 AWG-350 kcmil	1 AWG-350 kcmil
	0208 7	208.0	250	300 kcmil	1 AWG-350 kcmil	1 AWG-350 kcmil
MR10	0261 7	261.0	350	2xAWG2/0	1 AWG-350 kcmil	1 AWG-350 kcmil
	0325 7	325.0	450	2x4/0	1 AWG-350 kcmil	1 AWG-350 kcmil
	0385 7	385.0	500	2x250 kcmil	1 AWG-350 kcmil	1 AWG-350 kcmil
	0416 7	416.0	600	2x300 kcmil	1 AWG-350 kcmil	1 AWG-350 kcmil
MR12	0460 7	460	2x300	4x2/0	1 AWG-350 kcmil	1 AWG-350 kcmil
	0520 7	520	2x350	4x3/0	1 AWG-350 kcmil	1 AWG-350 kcmil
	0590 7	590	2x400	4x4/0	1 AWG-350 kcmil	1 AWG-350 kcmil
	0650 7	650	2x400	4x4/0	1 AWG-350 kcmil	1 AWG-350 kcmil
	0750 7	750	2x450	4x300	1 AWG-350 kcmil	1 AWG-350 kcmil
	0820 7	820	2x500	4x350	1 AWG-350 kcmil	1 AWG-350 kcmil

**Table 16: Drive fuses in North America, 208-240 V and 380-500 V, Mersen**

Enclosure size	Type	IL [A]	Catalogue number of the fuse	Fuse rating [A]	Number of fuses needed	Fuse size	Minimum prospective short circuit current
MR8	0140 2 0140 5	140	PC30UD69V250TF	250	3	30	1550
	0170 2 0170 5	170	PC30UD69V315TF	315	3	30	2250
	0205 2 0205 5	205	PC30UD69V350TF	350	3	30	2250
MR9	0261 2 0261 5	261	PC30UD69V400TF	400	3	30	3100
	0310 2 0310 5	310	PC30UD69V550TF	550	3	30	4700
MR10	0385 5	385	PC32UD69V630TF	630	3	32	4700
	0460 5	460	PC32UD69V700TF	700	3	32	5700
	0520 5	520	PC32UD69V900TF	900	3	32	8200
	0590 5	590	PC32UD69V1000TF	1000	3	32	9600
MR12	0650 5	650	PC32UD69V630TF	630	6	32	4700
	0730 5	730	PC32UD69V630TF	630	6	32	4700
	0820 5	820	PC32UD69V700TF	700	6	32	5700
	0920 5	920	PC32UD69V800TF	800	6	32	6800
	1040 5	1040	PC32UD69V900TF	900	6	32	8200
	1180 5	1180	PC32UD69V1000TF	1000	6	32	9600

**Table 17: Drive fuses in North America, 525-690 V, Mersen**

Enclosure size	Type	IL [A]	Catalogue number of the fuse	Fuse rating [A]	Number of fuses needed	Fuse size	Minimum prospective short circuit current
MR8	0080 7	80	PC30UD69V160TF	160	3	30	800
	0100 7	100	PC30UD69V200TF	200	3	30	1200
	0125 7	125	PC30UD69V250TF	250	3	30	1550
MR9	0144 7	144	PC30UD69V315TF	315	3	30	2250
	0170 7	170	PC30UD69V315TF	315	3	30	2250
	0208 7	208	PC30UD69V350TF	350	3	30	2550
MR10	0261 7	261	PC32UD69V450TF	450	3	32	3000
	0325 7	325	PC32UD69V500TF	500	3	32	3400
	0385 7	385	PC32UD69V630TF	630	3	32	4700
	0416 7	416	PC32UD69V700TF	700	3	32	5700
MR12	0460 7	460	PC32UD69V450TF	450	6	32	3000
	0520 7	520	PC32UD69V450TF	450	6	32	3000
	0590 7	590	PC32UD69V500TF	500	6	32	3400
	0650 7	650	PC32UD69V550TF	550	6	32	3900
	0750 7	750	PC32UD69V630TF	630	6	32	4700
	0820 7	820	PC32UD69V700TF	700	6	32	5700

## 6.2 BRAKE RESISTOR CABLES

**Table 18: Brake resistor cables, 208-240 V and 380-500 V**

Enclosure size	Type	IL [A]	Brake resistor cable (Cu) [mm <sup>2</sup> ]	Brake resistor cable (Cu) [AWG/kcmil]
MR8	0140 2 0140 5	140	3x70+35	4/0
	0170 2 0170 5	170	3x95+50	300
	0205 2 0205 5	205	3x120+70	350
MR9	0261 2 0261 5	261	2x(3x70+35)	2x3/0
	0310 2 0310 5	310	2x(3x95+50)	2x4/0
MR10	0385 5	385	2x(3x95+50)	2x4/0
	0460 5	460		
	0520 5	520	2x(3x120+70)	2x250
	0590 5	590		
MR12	0650 5	650	4x(3x95+50)	4x4/0
	0730 5	730		
	0820 5	820		
	0920 5	920		
	1040 5	1040	4x(3x120+70)	4x250
	1180 5	1180		

One of the cable conductors stays unconnected. Use a symmetrically shielded cable, same type as the mains and motor cables.



### NOTE!

The different Vacon® 100 applications have different functions. For example, the Vacon® 100 FLOW does not have the dynamic braking or the brake resistor functions.



**Table 19: Brake resistor cables, 525-690 V**

Enclosure size	Type *	IL [A]	Brake resistor cable (Cu) [mm <sup>2</sup> ]	Brake resistor cable (Cu) [AWG]
MR8	0080 6 0080 7	80	3x35+16	2
	0100 6 0100 7	100	3x50+25	1/0
	0125 6 0125 7	125	3x70+35	3/0
MR9	0144 6 0144 7	144	3x70+35	4/0
	0170 6 0170 7	170	3x95+50	250
	0208 6 0208 7	208	3x120+70	350
MR10	0261 6 0261 7	261	2x(3x70+35)	2x4/0
	0325 6 0325 7	325		
	0385 6 0385 7	385	2x(3x95+50)	2x250
	0416 6 0416 7	416		
MR12	0460 6 0460 7	460	4x(3x70+35)	4x4/0
	0520 6 0520 7	520		
	0590 6 0590 7	590		
	0650 6 0650 7	650	4x(3x95+50)	4x250
	0750 6 0750 7	750		
	0820 6 0820 7	820		

\* = The voltage class 6 is not available in North America.

One of the cable conductors stays unconnected. Use a symmetrically shielded cable, same type as the mains and motor cables.

**NOTE!**

The different Vacon® 100 applications have different functions. For example, the Vacon® 100 FLOW does not have the dynamic braking or the brake resistor functions.

### 6.3 PREPARING FOR THE CABLE INSTALLATION

- Before you start, make sure that none of the components of the AC drive is live. Read carefully the warnings in chapter 2 *Safety*.
- Make sure that the motor cables are sufficiently far from other cables.
- The motor cables must cross other cables at an angle of 90°.
- If it is possible, do not put the motor cables in long parallel lines with other cables.

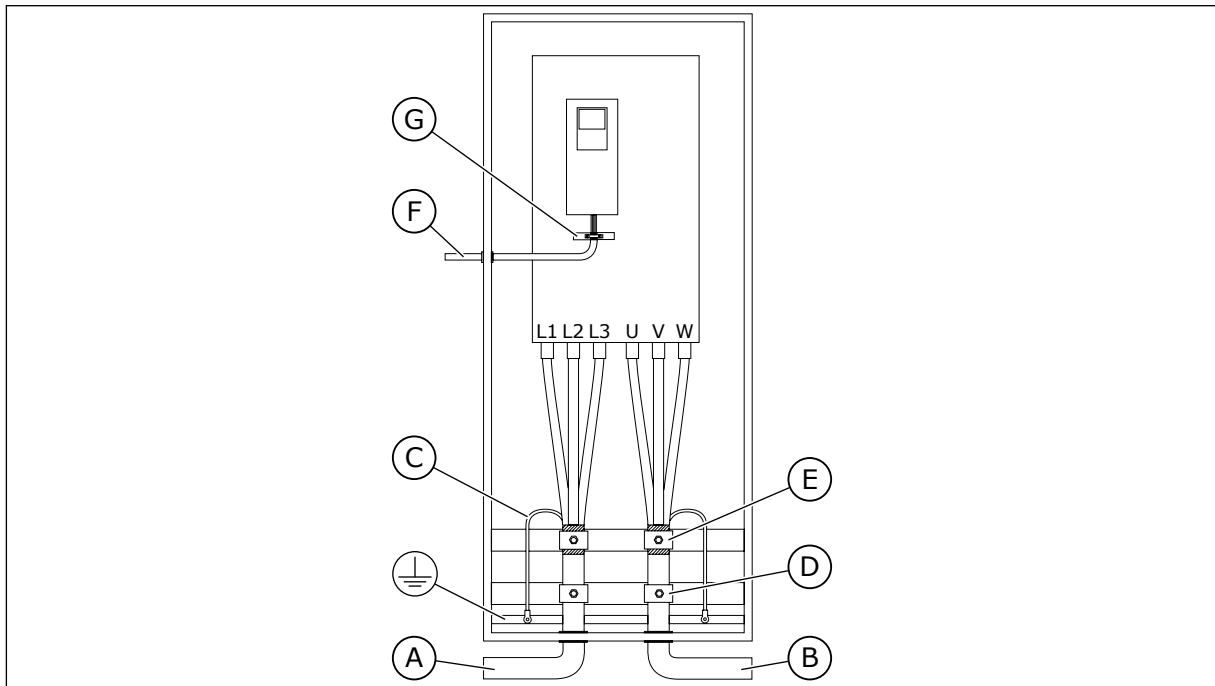

- |                            |   |
|----------------------------|---|
| A. The mains cables        | E. The grounding clamp for cable shield, 360° grounding |
| B. The motor cables        | F. The control cable                                    |
| C. The grounding conductor | G. The grounding bar of the control cable               |
| D. Pull relief             |   |

- Only use symmetrically EMC shielded motor cables.
- The maximum length of shielded motor cables is 200 m (MR8-MR12).
- If the cable insulation checks are necessary, see chapter 8.3 for instructions.
- If the motor cables are in long parallel lines with other cables, obey the minimum distances.
- The minimum distances are also valid between the motor cables and the signal cables of other systems.

**Table 20: The minimum distances between cables in long parallel lines**

The distance between cables [m]	The length of the shielded cable [m]	The distance between cables [ft]	The length of the shielded cable [ft]
0.3	≤ 50	1.0	≤ 164.0
1.0	≤ 200	3.3	≤ 656.1

## 6.4 CABLE INSTALLATION

### 6.4.1 ENCLOSURE SIZES MR8 AND MR9

1 MR9 only: Open the cover of the AC drive.

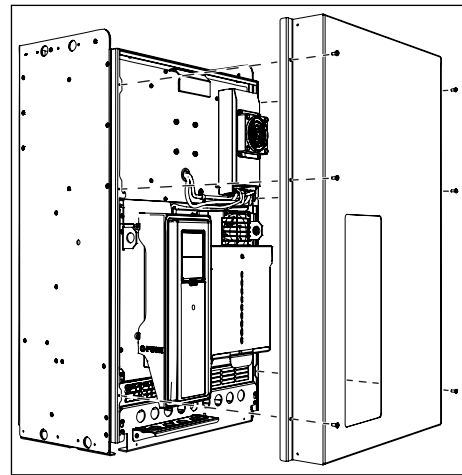

2 MR9 only: Loosen the screws and remove the sealing plate.

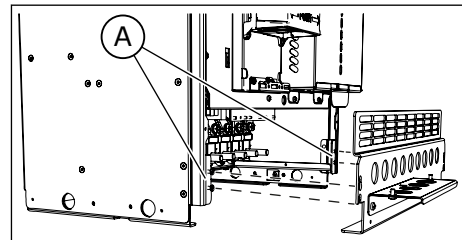

A. The screws

3 Find the motor cable terminals.

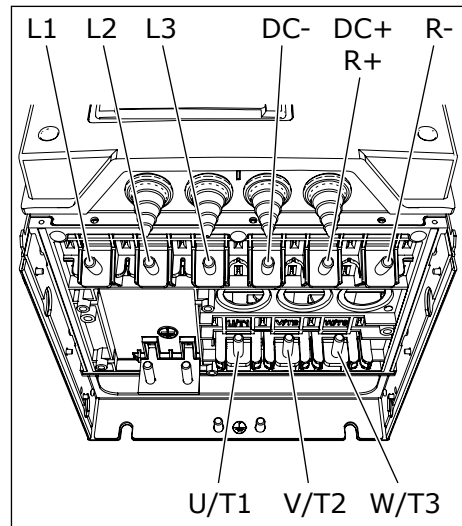

MR8

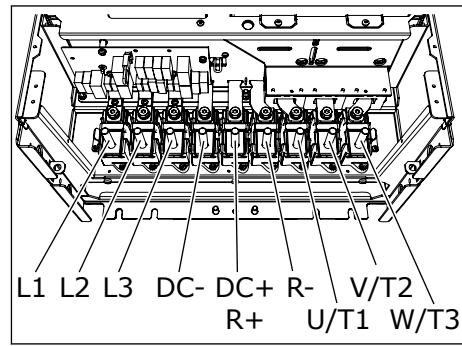

MR9

- 4 Connect the cables. The picture shows an example of good cabling.
- Connect the phase conductors of the mains cable and of the motor cable into the correct terminals. If you use a brake resistor cable, connect its conductors into the correct terminals.
  - Attach the grounding conductor of each cable to a grounding terminal with a grounding clamp for grounding conductor.
  - Make sure that the external grounding conductor is connected to the grounding bar. See chapter 2.4 *Grounding and earth fault protection*.
  - See the correct tightening torques in *Table 21*.

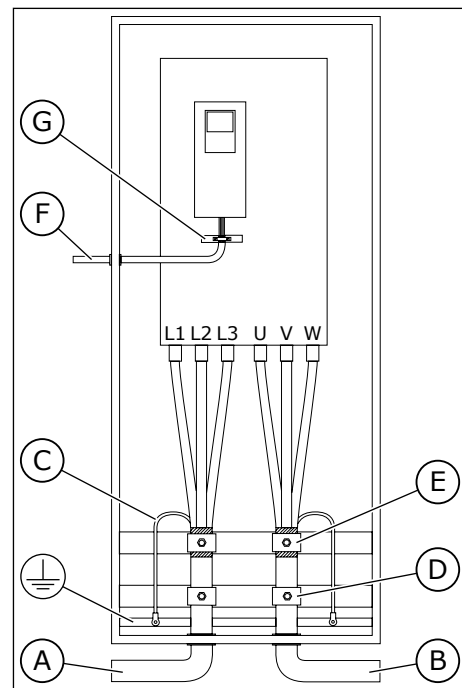

- The mains cables
- The motor cables
- The grounding conductor
- Pull relief
- The grounding clamp for cable shield, 360° grounding
- The control cable
- The grounding bar of the control cable

- 5 If you use many cables on one connector, put the cable lugs on top of each other.

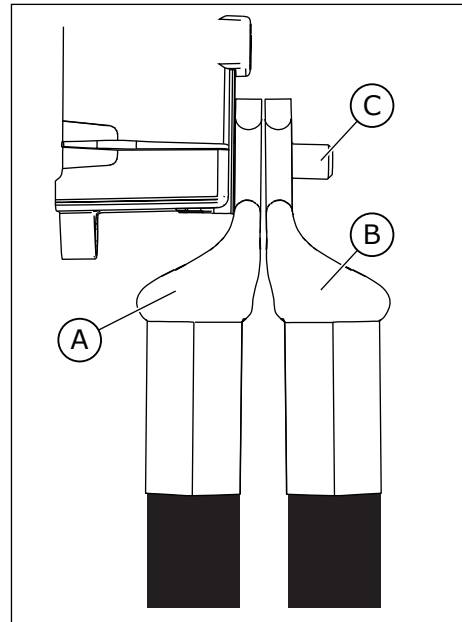

- A. The first cable lug  
 B. The second cable lug  
 C. The connector

- 6 If you use thick cables, put the cable insulators in between the terminals to prevent contact between the cables.

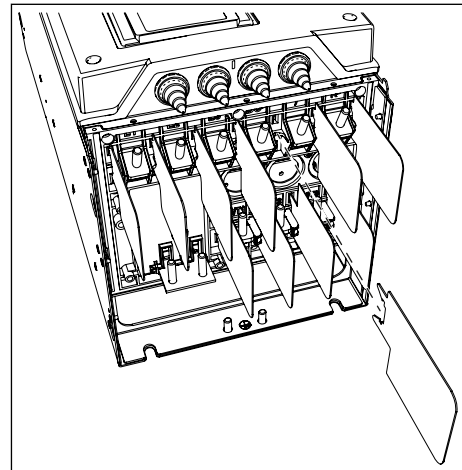

- 7 For MR9, attach the cover of the drive (unless you want to make the control connections first).
- 8 Make sure that the grounding conductor is connected to the motor and also to the terminals that are identified with  $\oplus$ .
- a) To obey the requirements of the standard EN61800-5-1, obey the instructions in chapter 2.4 *Grounding and earth fault protection*.
  - b) Connect the protective conductor to 1 of the screw connectors with a cable shoe and an M8 screw.

**Table 21: Tightening torques of the terminals, MR8 and MR9**

Enclosure size	Type	Tightening torque: the mains and motor cable terminals		Tightening torque: the grounding clamps for cable shield		Tightening torque: the grounding terminals	
		[Nm]	lb-in.	[Nm]	lb-in.	[Nm]	lb-in.
MR8	0140 2-0205 2 0140 5-0205 5 0080 6-0125 6 0080 7-0125 7	20	177	1.5	13.3	20	177
MR9	0261 2-0310 2 0261 5-0310 5 0144 6-0208 6 0144 7-0208 7	30-44	266	1.5	13.3	20	177

#### 6.4.2 ENCLOSURE SIZES MR10 AND MR12

The enclosure size MR12 includes 2 power units.

#### CONNECTING THE 2 POWER UNITS WITH AN OPTICAL FIBRE CABLE, MR12

- 1 Remove the service lid of each power unit.
- 2 Connect the power units together with the optical fibre cable.

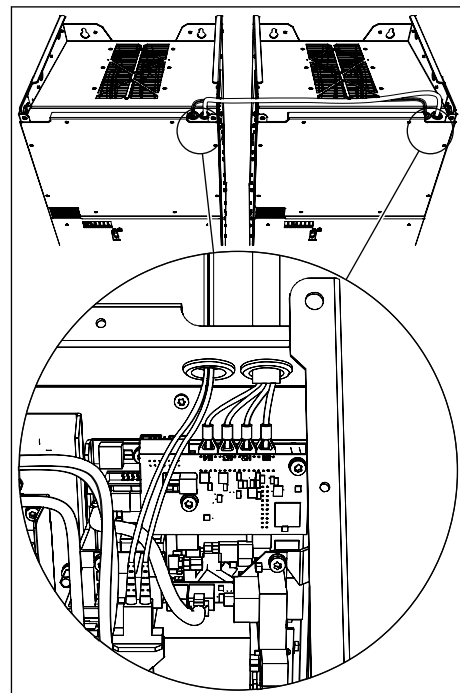

**CABLE INSTALLATION WITHOUT THE OPTIONS MODULE**

1 Find the motor cable terminals.

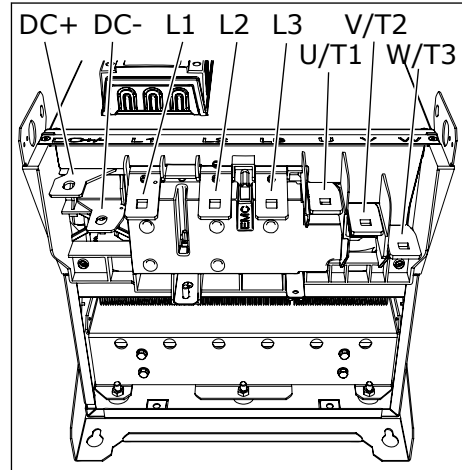

2 In MR12, connect the DC terminals of the 2 power units with the DC link cable. Connect the DC+ terminals together, and the DC- terminals together. The DC link cable is included in the delivery.

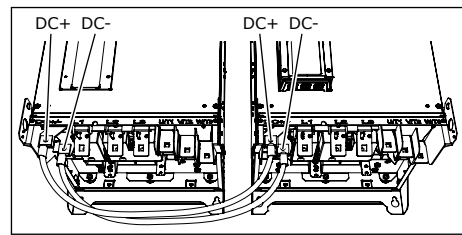

3 Use the external power connection block (+PCTB) if you have it. For MR12 there are 2 external power connection blocks.

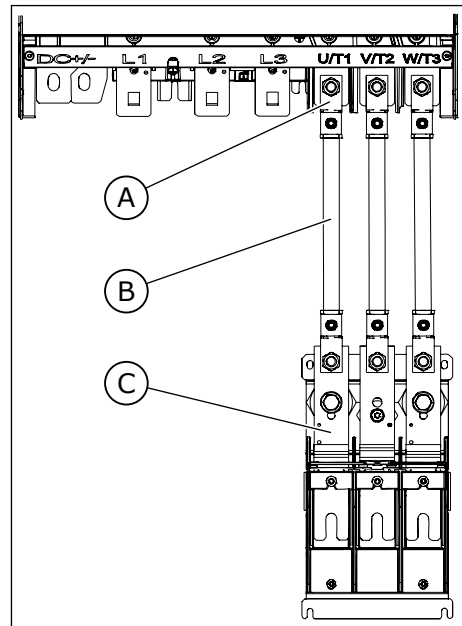

- A. The terminals U, V, W
- B. The power cable (not included in delivery of the option)
- C. The external power connection block



- 4 Connect the cables. The picture shows an example of good cabling.
- a) Connect the phase conductors of the mains cable and of the motor cable into the correct terminals. If you use a brake resistor cable, connect its conductors into the correct terminals.
  - b) Attach the grounding conductor of each cable to a grounding terminal with a grounding clamp for grounding conductor.
  - c) Make sure that the external grounding conductor is connected to the grounding bar. See chapter 2.4 *Grounding and earth fault protection*.
  - d) See the correct tightening torques in *Table 23*.

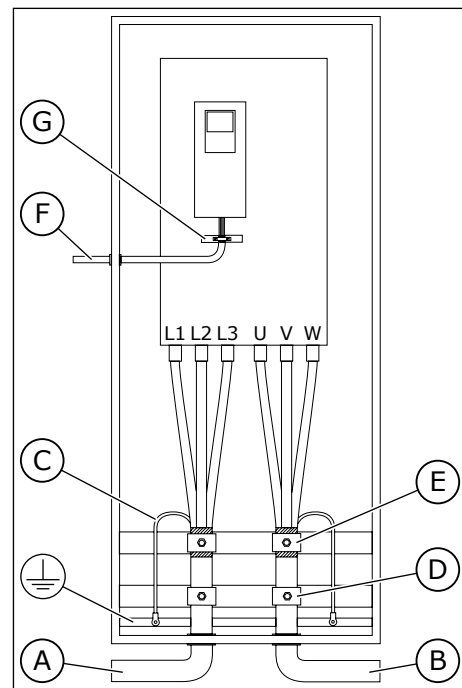

- A. The mains cables
- B. The motor cables
- C. The grounding conductor
- D. Pull relief
- E. The grounding clamp for cable shield, 360° grounding
- F. The control cable
- G. The grounding bar of the control cable

5 If you use many cables on one connector, put the cable lugs on top of each other.

- The pictures show the connection in MR10 and MR12.
- The bolt holder of the connector keeps the bolt still when you turn the nut.

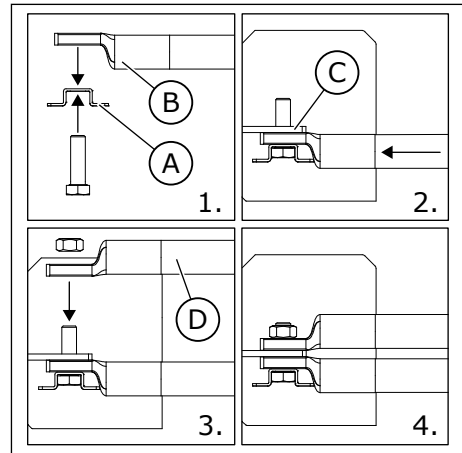

- A. The bolt holder of the connector
- B. The first cable lug
- C. The connector
- D. The second cable lug

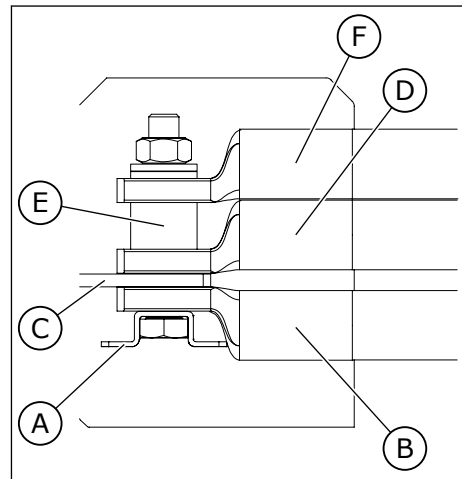

- A. The bolt holder of the connector
- B. The first cable lug
- C. The connector
- D. The second cable lug
- E. The connection bush
- F. The third cable lug

- 6 To make EMC grounding, expose the shield of all 3 motor cables and make a 360-degree connection between the cable and the grounding clamp for cable shield.
- 7 Attach the terminal cover, and then the options module cover.

- 8 Make sure that the grounding conductor is connected to the motor and also to the terminals that are identified with  $\oplus$ .
- a) To obey the requirements of the standard EN61800-5-1, obey the instructions in chapter 2.4 *Grounding and earth fault protection*.

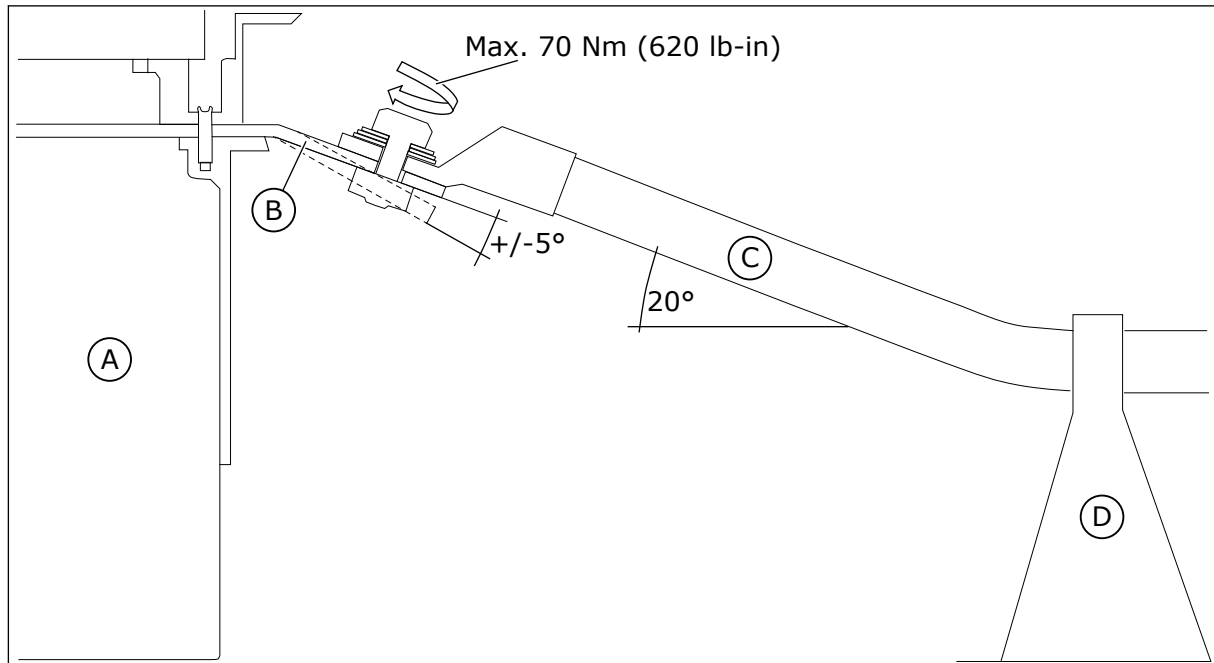

Fig. 17: Mechanical support for cables when the drive does not have the options module

- |   |                      |
|---|----------------------|
| A. The AC drive   | C. The power cable   |
| B. The connection busbar. Terminals L1, L2, L3, U/T1, V/T2, W/T3. | D. The cable support |



**NOTE!**

You must make sure that creepage and air distances are sufficient in your installation and that they agree with the local regulations.

**Table 22: Tightening torques of the terminals, MR10 or MR12 without options module**

Enclosure size	Type	Tightening torque: the mains and motor cable terminals		Tightening torque: the grounding terminals	
		[Nm]	lb-in.	[Nm]	lb-in.
MR10	0385 5-0590 5 0261 6-0416 6 0261 7-0461 7	55-70 *	490-620 *	20	177
MR12	0650 5-1180 5 0460 6-0820 6 0460 7-0820 7	55-70 *	490-620 *	20	177

\* Counter torque is required.

**CABLE INSTALLATION WITH AN OPTIONS MODULE**

- 1 Loosen the screws of the terminal cover and remove it.

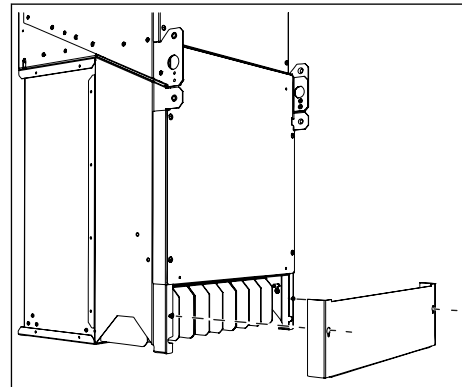

- 2 Find the motor cable terminals.

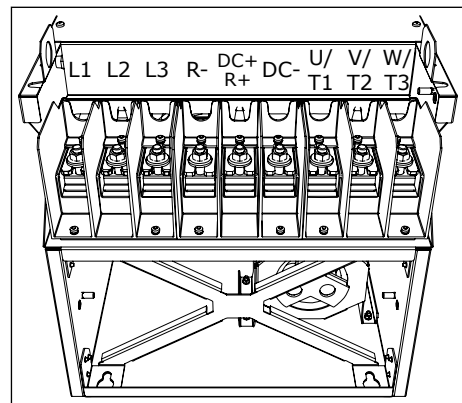

- 3 In MR12, connect the DC terminals of the 2 power units with the DC link cable. Connect the DC+ terminals together, and the DC- terminals together. The DC link cable is included in the delivery.

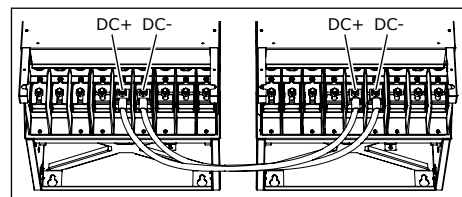

- 4 Connect the cables. The picture shows an example of good cabling.
- Connect the phase conductors of the mains cable and of the motor cable into the correct terminals. If you use a brake resistor cable, connect its conductors into the correct terminals.
  - Attach the grounding conductor of each cable to a grounding terminal with a grounding clamp for grounding conductor.
  - Make sure that the external grounding conductor is connected to the grounding bar. See chapter 2.4 *Grounding and earth fault protection*.
  - See the correct tightening torques in *Table 23*.

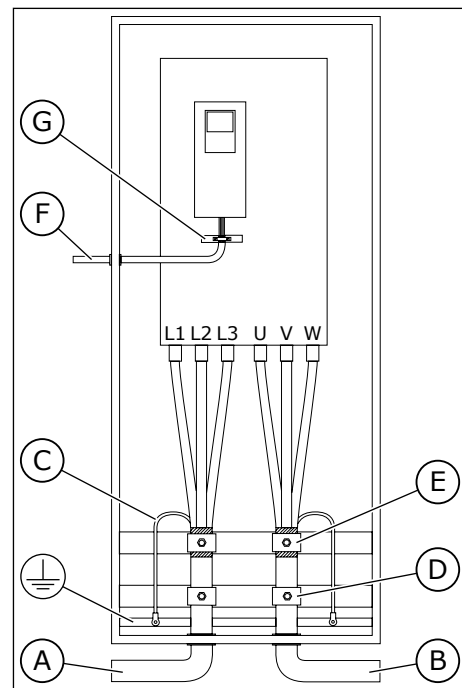

- The mains cables
- The motor cables
- The grounding conductor
- Pull relief
- The grounding clamp for cable shield, 360° grounding
- The control cable
- The grounding bar of the control cable

5 If you use many cables on one connector, put the cable lugs on top of each other.

- The pictures show the connection in MR10 and MR12.
- The bolt holder of the connector keeps the bolt still when you turn the nut.

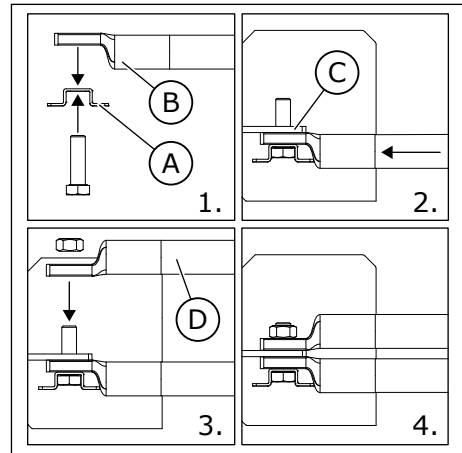

- A. The bolt holder of the connector
- B. The first cable lug
- C. The connector
- D. The second cable lug

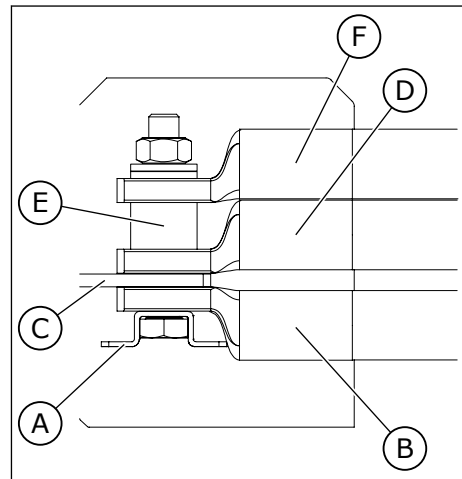

- A. The bolt holder of the connector
- B. The first cable lug
- C. The connector
- D. The second cable lug
- E. The connection bush
- F. The third cable lug

6 To make EMC grounding, expose the shield of all 3 motor cables and make a 360-degree connection between the cable and the grounding clamp for cable shield.

7 Attach the terminal cover, and then the options module cover.

- 8 Make sure that the grounding conductor is connected to the motor and also to the terminals that are identified with ⊕ .
- a) To obey the requirements of the standard EN61800-5-1, obey the instructions in chapter 2.4 *Grounding and earth fault protection*.

**Table 23: Tightening torques of the terminals, MR10 or MR12 with an options module**

Enclosure size	Type	Tightening torque: the mains and motor cable terminals		Tightening torque: the grounding terminals	
		[Nm]	lb-in.	[Nm]	lb-in.
MR10	0385 5-0590 5 0261 6-0416 6 0261 7-0416 7	55-70	490-620	20	177
MR12	0650 5-1180 5 0460 6-0820 6 0460 7-0820 7	55-70	490-620	20	177

# 7 CONTROL UNIT

## 7.1 CONTROL UNIT COMPONENTS

The control unit of the AC drive contains the standard boards and the option boards. The option boards are connected to the slots of the control board (see 7.4 *Installation of option boards*).

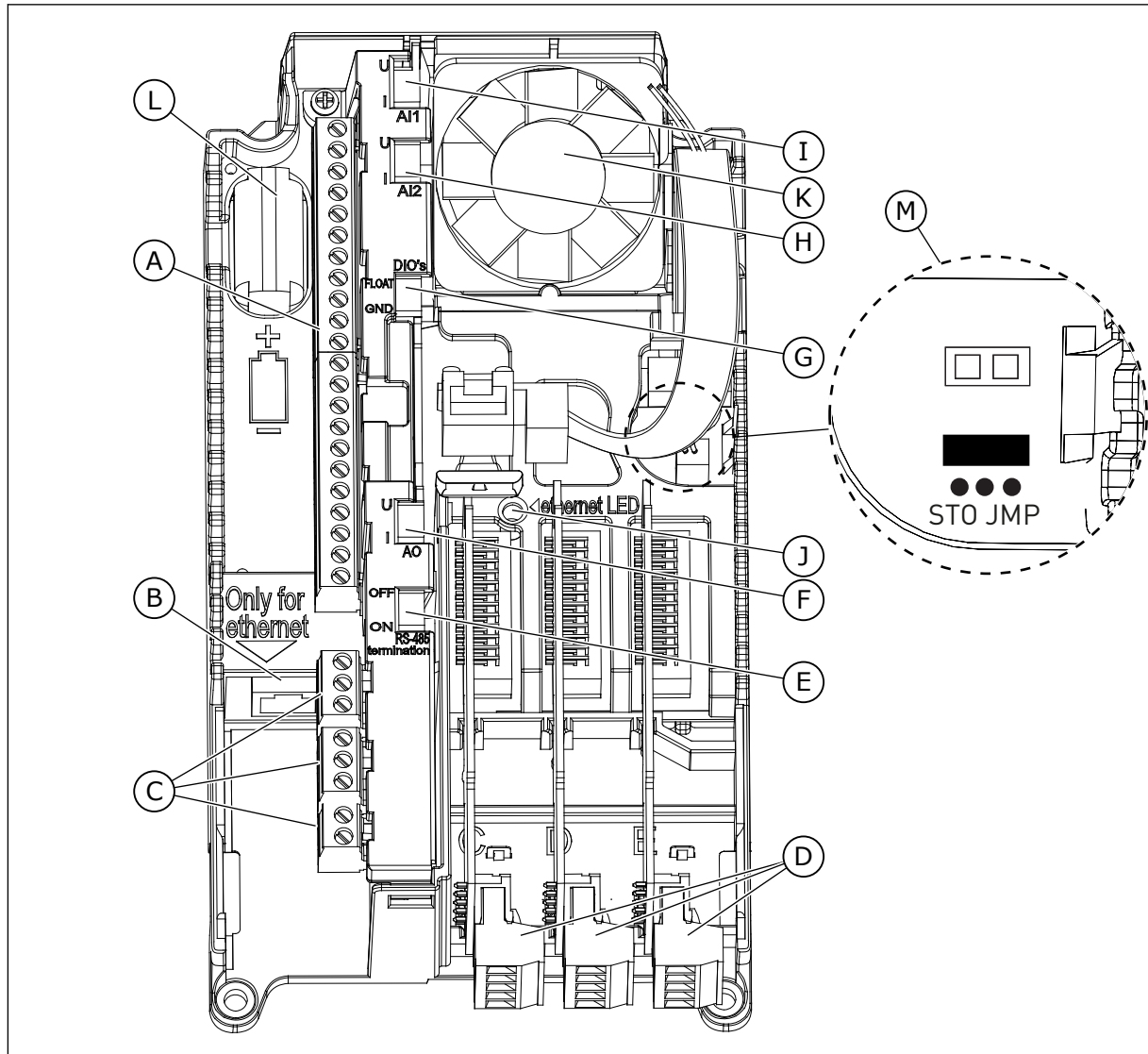

Fig. 18: The components of the control unit

- |   |   |
|---|---|
| <ul style="list-style-type: none"> <li>A. The control terminals for the standard I/O connections</li> <li>B. The Ethernet connection</li> <li>C. The relay board terminals for 3 relay outputs or 2 relay outputs and a thermistor</li> <li>D. The option boards</li> </ul> | <ul style="list-style-type: none"> <li>E. A DIP switch for the RS485 bus termination</li> <li>F. A DIP switch for the signal selection of Analogue Output</li> <li>G. A DIP switch for the isolation of the digital inputs from ground</li> <li>H. A DIP switch for the signal selection of Analogue Input 2</li> </ul> |
|---|---|



- |  |  |
|--|--|
| I. A DIP switch for the signal selection of Analogue Input 1 | K. A fan (only in IP54 of MR4 and of MR5)                                    |
| J. The status indicator of the Ethernet connection           | L. The battery for the RTC   |
|  | M. The location and the default position of the Safe Torque Off (STO) jumper |

When you receive the AC drive, the control unit contains the standard control interface. If you included special options in your order, the AC drive will be as in your order. On the next pages, you will find information on the terminals and general wiring examples.

It is possible to use the drive with an external power source with these properties: +24 VDC  $\pm 10\%$ , minimum 1000 mA. Connect the external power source to terminal 30. This voltage is sufficient to keep the control unit on and for you to set the parameters. The measurements of the main circuit (for example, the DC link voltage, and the unit temperature) are not available when the drive is not connected to mains.

The status LED of the drive shows the status of the drive. The status LED is located in the control panel, below the keypad, and it can show 5 different statuses.

**Table 24: The statuses of the status LED of the drive**

Colour of the LED light	Status of the drive
Blinking slowly	Ready
Green	Run
Red	Fault
Orange	Alarm
Blinking fast	Downloading software

## 7.2 CONTROL UNIT CABLING

The standard I/O board has 22 fixed control terminals and 8 relay board terminals. You can see the standard connections of the control unit and the descriptions of signals in *Fig. 19*.

### 7.2.1 SELECTION OF THE CONTROL CABLES

The control cables must be a minimum of 0.5 mm<sup>2</sup> screened multicore cables. See more on the cable types in *6.1.1 Cable and fuse sizes*. The terminal wires must be a maximum of 2.5 mm<sup>2</sup> for the relay board terminals and other terminals.

**Table 25: The tightening torques of the control cables**

The terminal	The terminal screw	The tightening torque	
		Nm	lb-in.
All the terminals of the I/O board and the relay board	M3	0.5	4.5

## 7.2.2 CONTROL TERMINALS AND DIP SWITCHES

Here you see the basic description of the terminals of the standard I/O board and the relay board. For more information, see *11.1 Technical data on control connections*.

Some terminals are assigned for signals that have optional functions that you can use with the DIP switches. See more in *7.2.2.1 Selection of terminal functions with DIP switches*.



		Standard I/O board																	
		Terminal	Signal	Description															
Reference potentiometer 1...10kΩ  2-wire transmitter Actual value I = (0)4...20mA	1	+10 Vref	Reference output																
	2	AI1+	Analogue input, voltage or current	Frequency reference															
	3	AI1-	Analogue input common, (current)																
	4	AI2+	Analogue input, voltage or current	Frequency reference															
	5	AI2-	Analogue input common, (current)																
mA	6	24Vout	24V auxiliary voltage																
	7	GND	I/O ground																
	8	DI1	Digital input 1	Start forward															
	9	DI2	Digital input 2	Start reverse															
	10	DI3	Digital input 3	External fault															
	11	CM	Common for DI1-DI6	*)															
	12	24Vout	24V auxiliary voltage																
	13	GND	I/O ground																
	14	DI4	Digital input 4	<table border="1"> <tr> <td>DI4</td> <td>DI5</td> <td>Freq. ref.</td> </tr> <tr> <td>Open</td> <td>Open</td> <td>Analog input 1</td> </tr> <tr> <td>Closed</td> <td>Open</td> <td>Preset Freq. 1</td> </tr> <tr> <td>Open</td> <td>Closed</td> <td>Preset Freq. 2</td> </tr> <tr> <td>Closed</td> <td>Closed</td> <td>Preset Freq. 3</td> </tr> </table>	DI4	DI5	Freq. ref.	Open	Open	Analog input 1	Closed	Open	Preset Freq. 1	Open	Closed	Preset Freq. 2	Closed	Closed	Preset Freq. 3
	DI4	DI5	Freq. ref.																
Open	Open	Analog input 1																	
Closed	Open	Preset Freq. 1																	
Open	Closed	Preset Freq. 2																	
Closed	Closed	Preset Freq. 3																	
15	DI5	Digital input 5																	
16	DI6	Digital input 6	Fault reset																
RUN	17	CM	Common for DI1-DI6	*)															
	18	AO1+	Analogue signal (+output)	Output frequency															
	19	AO1-/GND	Analogue output common / I/O ground																
	30	+24Vin	24V auxiliary input voltage																
	A	RS485	Serial bus, negative	Modbus RTU BACnet, N2															
	B	RS485	Serial bus, positive																
	21	RO1 NC	Relay output 1	RUN															
	22	RO1 CM																	
	23	RO1 NO																	
	24	RO2 NC	Relay output 2	FAULT															
	25	RO2 CM																	
	26	RO2 NO																	
	32	RO3 CM	Relay output 3	READY															
	33	RO3 NO																	

Fig. 19: The signals of the control terminals on the standard I/O board, and a connection example. If you include the option code +SBF4 in your order, the relay output 3 is replaced with a thermistor input.

\* = You can isolate digital inputs from ground with a DIP switch. See 7.2.2.2 Isolation of digital inputs from ground.

There are 2 different relay boards available.

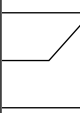
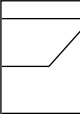
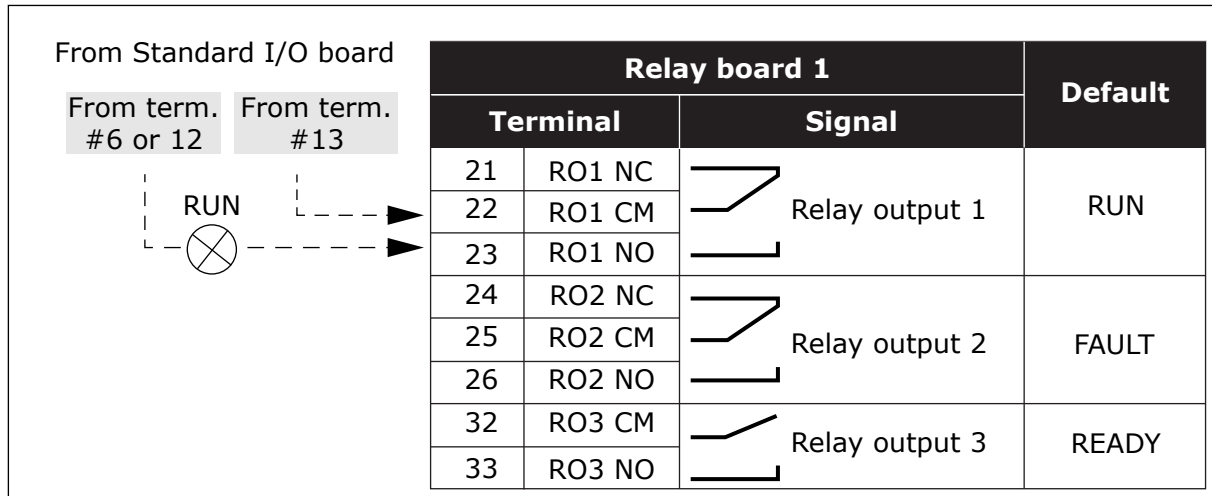

Fig. 20: The standard relay board (+SBF3)

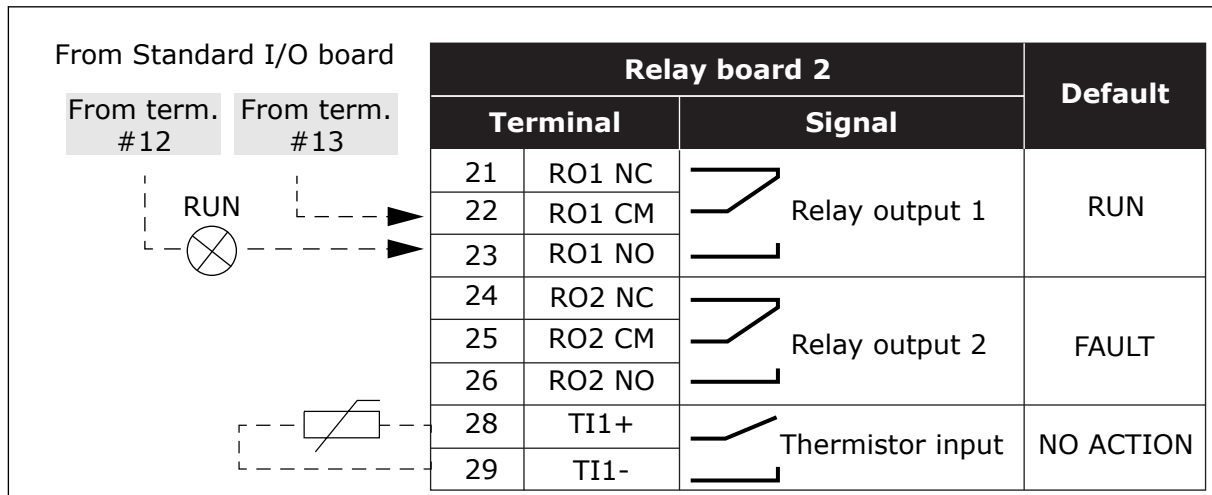

Fig. 21: The optional relay board (+SBF4)



**NOTE!**

The Thermistor input function is not automatically active.

To use the Thermistor input function, you must activate the parameter Thermistor Fault in the software. See the Application Manual.

7.2.2.1 Selection of terminal functions with DIP switches

You can make 2 selections with the DIP switches for specified terminals. The switches have 2 positions: up and down. You can see the location of the DIP switches and the possible selections in Fig. 22.

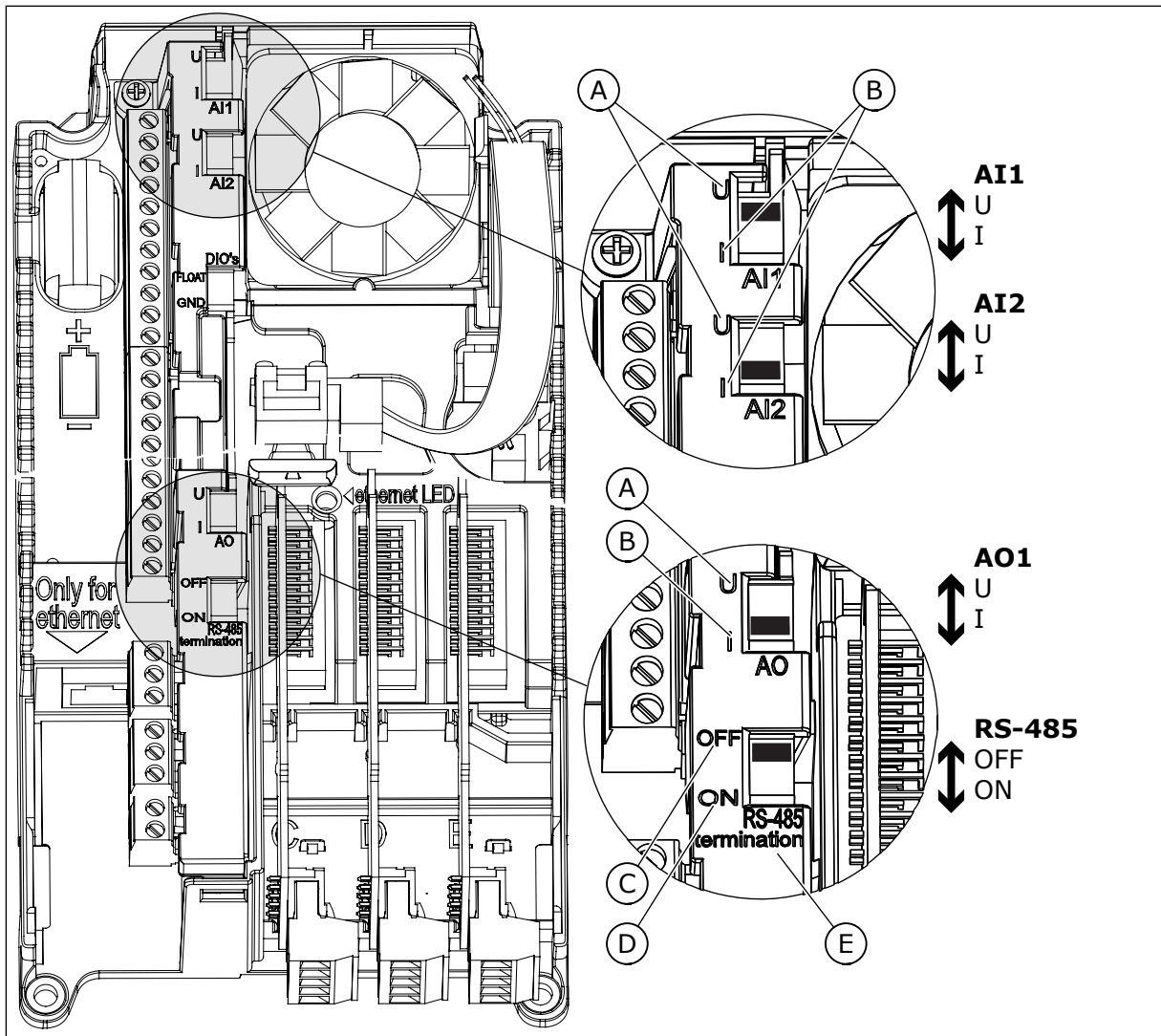

Fig. 22: The selections of the DIP switches

- A. The voltage signal (U), 0-10 V input
- B. The current signal (I), 0-20 mA input
- C. OFF
- D. ON
- E. The RS-485 bus termination

Table 26: The default positions of the DIP switches

The DIP switch	The default position
AI1	U
AI2	I
AO1	I
RS485 bus termination	OFF

### 7.2.2.2 Isolation of digital inputs from ground

It is possible to isolate from ground the digital inputs (terminals 8-10 and 14-16) on the standard I/O board. To do this, change the position of a DIP switch on the control board.

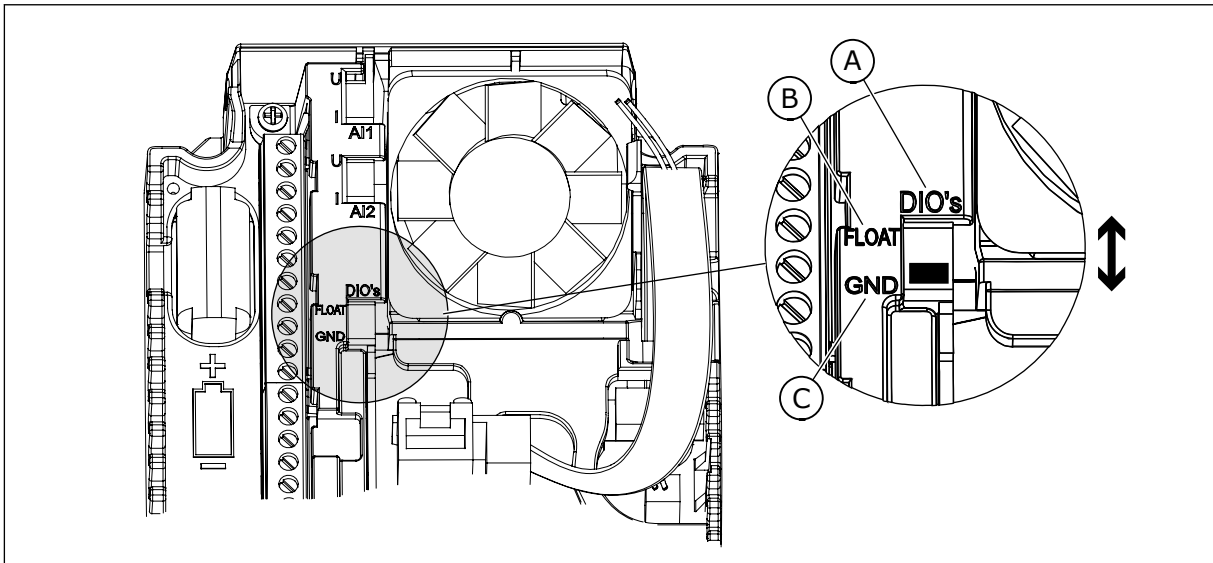

Fig. 23: Change the position of this switch to isolate the digital inputs from ground

- A. The digital inputs
- B. Floating
- C. Connected to GND (default)

## 7.3 FIELDBUS CONNECTION

You can connect the drive to fieldbus with an RS485 or an Ethernet cable. If you use an RS485 cable, connect it to terminal A and B of the standard I/O board. If you use an Ethernet cable, connect it to the Ethernet terminal below the cover of the drive.

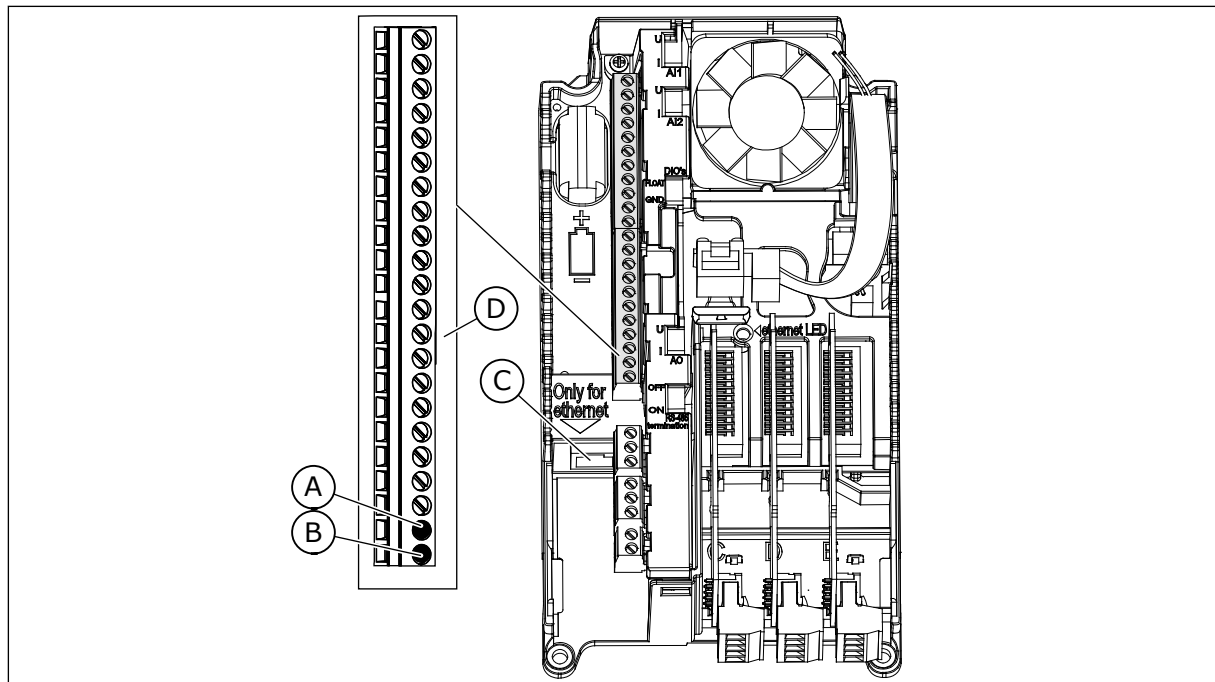

Fig. 24: The Ethernet and RS485 connections

- A. RS485 terminal A = Data -    C. The Ethernet terminal  
 B. RS485 terminal B = Data +    D. The control terminals

### 7.3.1 USING FIELDBUS THROUGH AN ETHERNET CABLE

**Table 27: Ethernet cable data**

Item	Description
The plug type	A shielded RJ45 plug, maximum length 40 mm (1.57 in)
The cable type	CAT5e STP
The cable length	Maximum 100 m (328 ft)

#### ETHERNET CABLING

- 1 Connect the Ethernet cable to its terminal.
- 2 Put the cover of the drive back. Keep the distance between the Ethernet cable and the motor cable at a minimum of 30 cm (11.81 in).

See more in the Installation Manual of the fieldbus that you have.

### 7.3.2 USING FIELDBUS THROUGH AN RS485 CABLE

**Table 28: RS485 cable data**

Item	Description
The plug type	2.5 mm <sup>2</sup>
The cable type	STP (shielded twisted pair), Belden 9841 or almost the same
The cable length	So that it agrees with the fieldbus. See the fieldbus manual.

#### RS485 CABLING

- 1 Remove approximately 15 mm (0.59 in) of the grey shield of the RS485 cable. Do this for the 2 fieldbus cables.
  - a) Strip the cables for approximately 5 mm (0.20 in) to put them in the terminals. Do not keep more than 10 mm (0.39 in) of the cable outside the terminals.
  - b) Strip the cable at such a distance from the terminal that you can attach it to the frame with the grounding clamp for control cable. Strip the cable at a maximum length of 15 mm (0.59 in). Do not remove the aluminium shield of the cable.

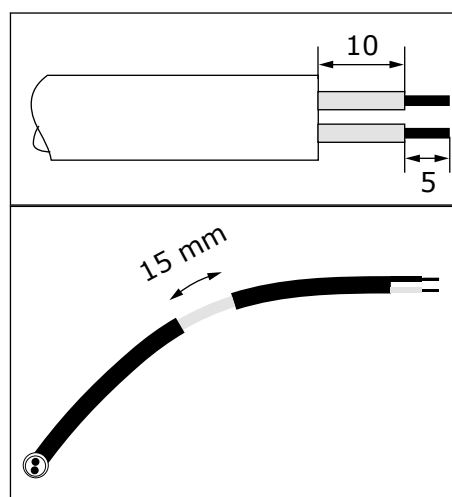



- 2 Connect the cable to the standard I/O board of the drive, in terminals A and B.

- A = negative
- B = positive

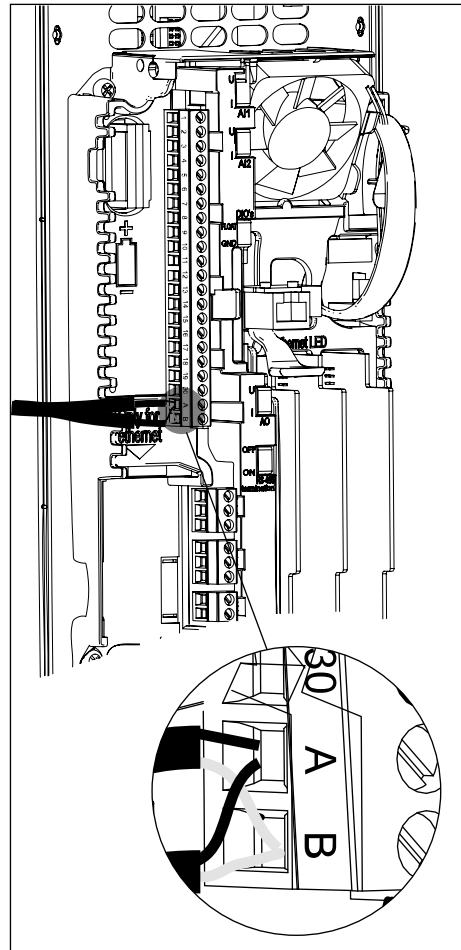

- 3 Attach the shield of the cable to the frame of the drive with a grounding clamp for control cable to make a grounding connection.

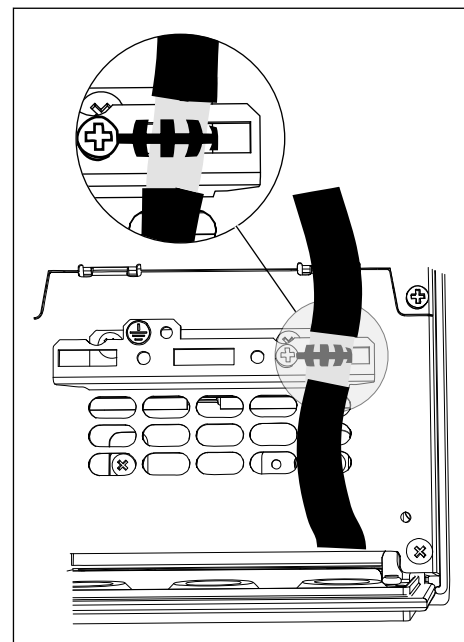

- 4 If the drive is the last device on the fieldbus line, set the bus termination.
  - a) Find the DIP switches on the left side of the control unit of the drive.
  - b) Set the DIP switch of the RS485 bus termination to the ON position.
  - c) Biasing is built in the bus termination resistor. The termination resistance is 220 Ω.

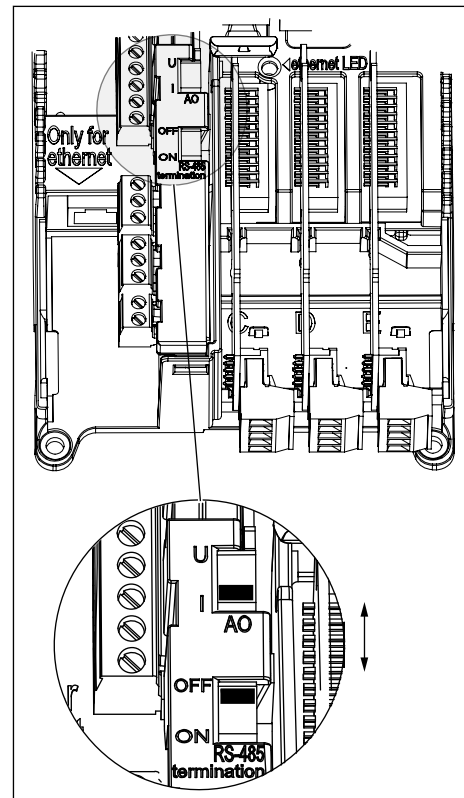

- 5 Set the bus termination for the first and the last device of the fieldbus line. We recommend that the first device on the fieldbus is the master device.

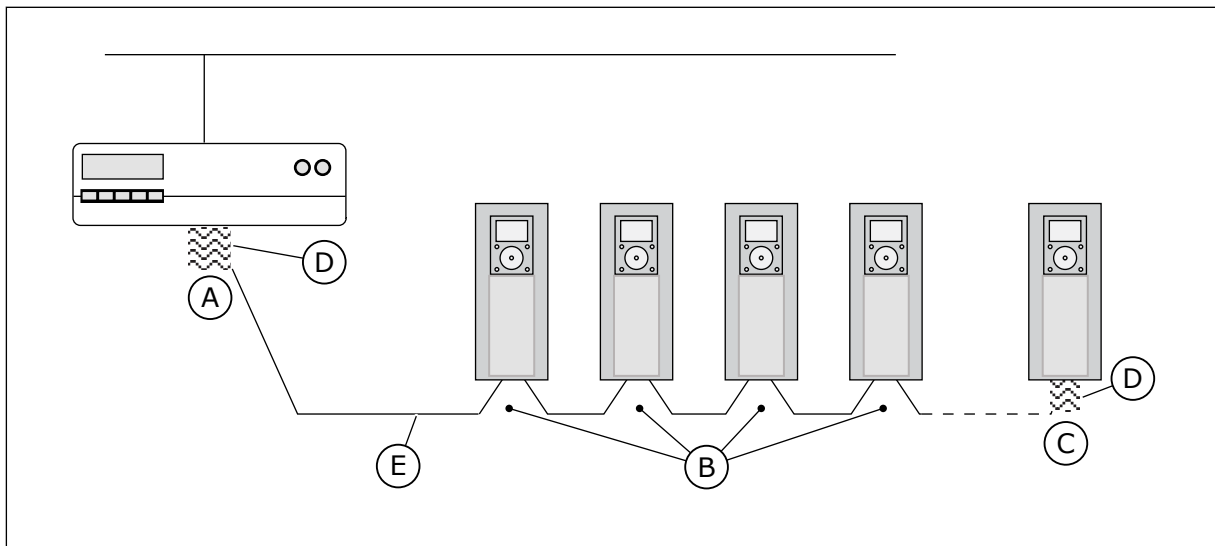

- |   |  |
|---|--|
| A. The termination is activated                   | D. The bus termination. The resistance is 220 Ω. |
| B. The termination is deactivated                 | E. The fieldbus                                  |
| C. The termination is activated with a DIP switch |  |

**NOTE!**

If you do power-down to the last device, there is no bus termination.

## 7.4 INSTALLATION OF OPTION BOARDS

**CAUTION!**

Do not install, remove, or replace option boards on the drive when the power is on. Doing this can cause damage to the boards.

Install the option boards into the option board slots of the drive. Refer to *Table 29*.

**Table 29: The option boards and their correct option board slots**

Type of the option board	Description of the option board	The correct slot or slots
OPTB1	The I/O expander board	C, D, E
OPTB2	The Thermistor relay board	C, D, E
OPTB4	The I/O expander board	C, D, E
OPTB5	The Relay board	C, D, E
OPTB9	The I/O expander board	C, D, E
OPTBF	The I/O expander board	C, D, E
OPTBH	The Temperature measurement board	C, D, E
OPTBJ	The Safe Torque Off board	E
OPTC4	The LonWorks fieldbus board	D, E
OPTE3	The Profibus DPV1 fieldbus board	D, E
OPTE5	The Profibus DPV1 fieldbus board (with a type D connector)	D, E
OPTE6	The CanOpen fieldbus board	D, E
OPTE7	The DeviceNet fieldbus board	D, E

**THE INSTALLATION PROCEDURE**

- 1 Open the cover of the AC drive.



**WARNING!**

Do not touch the control terminals. They can have a dangerous voltage also when the drive is disconnected from mains.

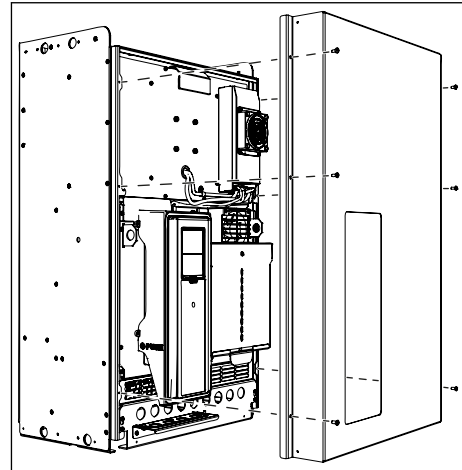

- 2 If you have an OPTB or an OPTC option board, make sure that the label on it says "dv" (dual voltage). This shows that the option board is compatible with the drive.



**NOTE!**

It is not possible to install option boards that are not compatible with the drive.

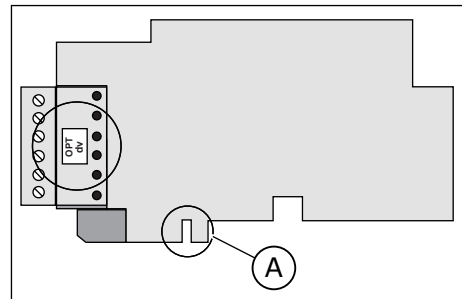

A. The slot coding

- 3 To get access to the option board slots, open the cover of the control unit.

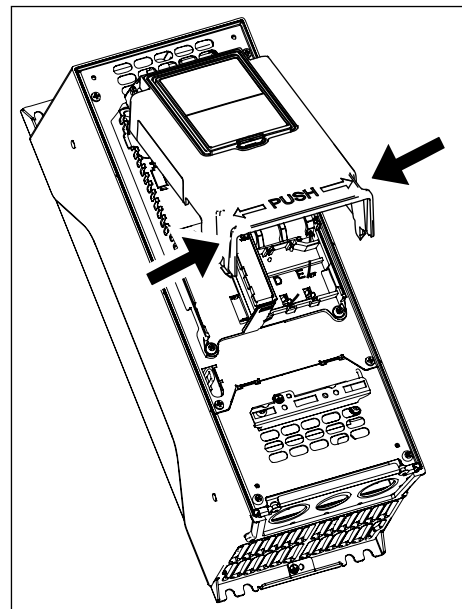

- 4 Install the option board into the correct slot: C, D or E. See *Table 29*.

- a) The option board has a slot coding, because of which it is not possible to install the option board in an incorrect slot.

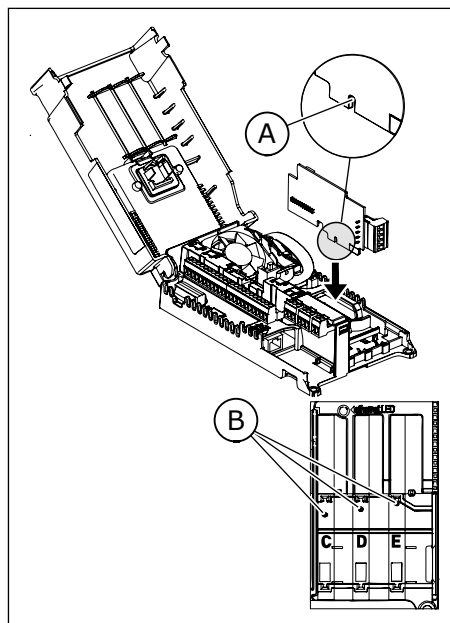

- A. The slot coding  
B. The option board slots

- 5 Close the cover of the control unit. Put the cover of the AC drive back.

## 7.5 INSTALLATION OF A BATTERY FOR THE REAL TIME CLOCK (RTC)

To use the Real Time Clock (RTC), you must install a battery in the drive.

- 1 Use a ½ AA battery with 3.6 V and a capacity of 1000-1200 mAh. You can use, for example, a Panasonic BR-1/2 AA or a Vitzrocell SB-AA02.
- 2 Install the battery on the left side of the control panel. See *7.1 Control unit components*.

The battery will last approximately 10 years. See more about the functions of the RTC in the Application Manual.

## 7.6 GALVANIC ISOLATION BARRIERS

The control connections are isolated from mains. The GND terminals are permanently connected to I/O ground.

The digital inputs on the standard I/O board can be galvanically isolated from the I/O ground. To isolate the digital inputs, use the DIP switch that has the positions FLOAT and GND.

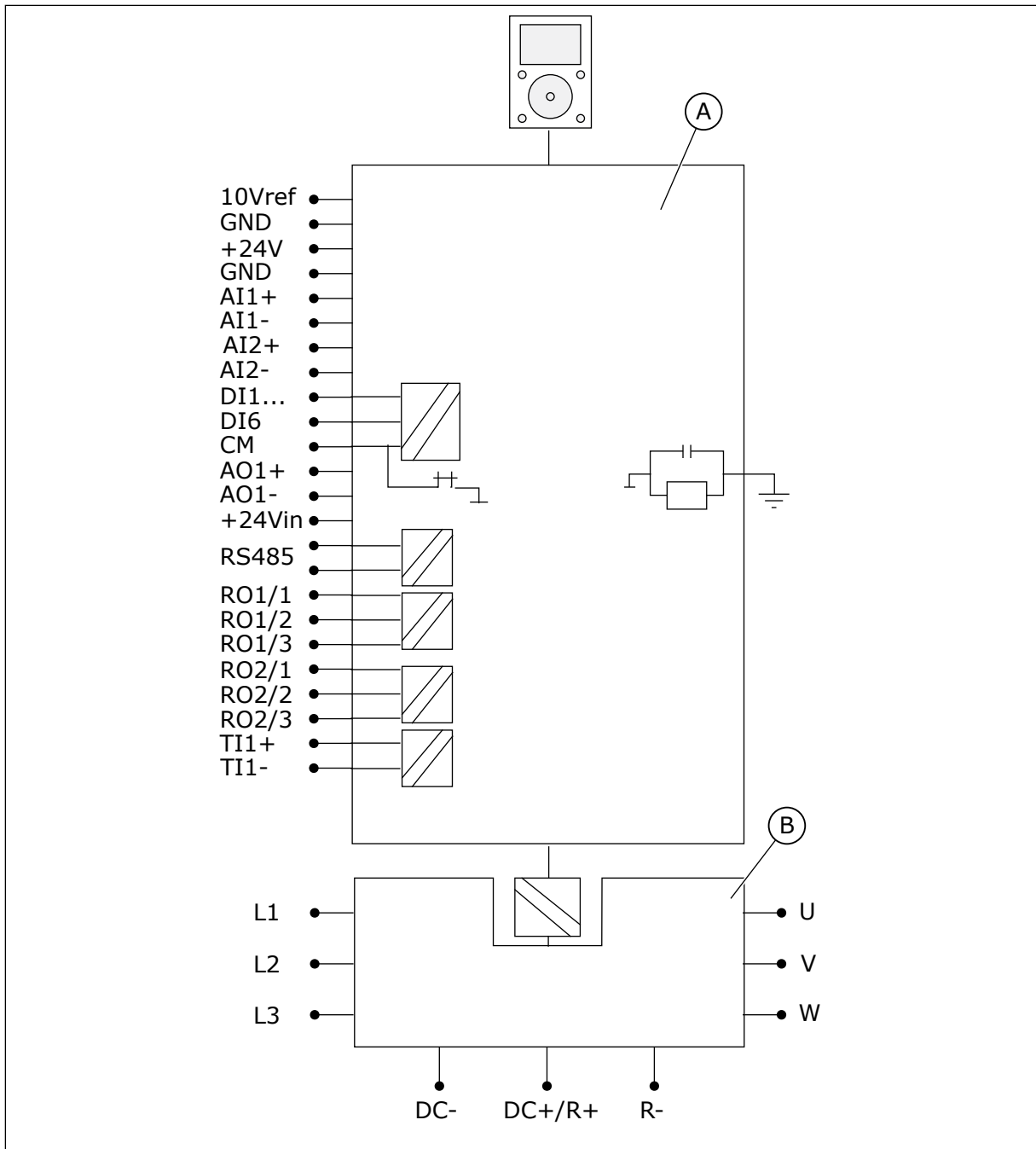

Fig. 25: The galvanic isolation barriers

A. The control unit

B. The power unit

## 8 COMMISSIONING AND ADDITIONAL INSTRUCTIONS

### 8.1 COMMISSIONING SAFETY

Before you start the commissioning, read these warnings.

**WARNING!**

Do not touch the internal components or the circuit boards of the drive when the drive is connected to mains. These components are live. A contact with this voltage is very dangerous. The galvanically isolated control terminals are not live.

**WARNING!**

Do not touch the motor cable terminals U, V, W, the brake resistor terminals or the DC terminals when the drive is connected to mains. These terminals are live when the drive is connected to mains, also when the motor does not operate.

**WARNING!**

Do not make connections to or from the AC drive when it is connected to mains. There is a dangerous voltage.

**WARNING!**

To do work on the connections of the drive, disconnect the drive from mains. Wait 5 minutes before you open the cabinet door or the cover of the drive. Then use a measuring device to make sure that there is no voltage. The connections of the drive are live 5 minutes after it is disconnected from mains.

**WARNING!**

Before you do electrical work, make sure that there is no voltage.

**WARNING!**

Do not touch the control terminals. They can have a dangerous voltage also when the drive is disconnected from mains.

**WARNING!**

Before you connect the drive to mains, make sure that the front cover and the cable cover of the drive are closed. The connections of the AC drive are live when the drive is connected to mains.

## 8.2 OPERATION OF THE MOTOR

### 8.2.1 CHECKS BEFORE STARTING THE MOTOR

**Before you start the motor, do these checks.**

- Make sure that all the START and STOP switches that are connected to the control terminals are in the STOP position.
- Make sure that you can start the motor safely.
- Activate the Start-up wizard. See the Application Manual for the AC drive that you have.
- Set the maximum frequency reference (that is, the maximum speed of the motor), so that it agrees with the motor and the device that is connected to the motor.

### 8.3 MEASURING THE CABLE AND MOTOR INSULATION

Do these checks if necessary.

#### The insulation checks of the motor cable

1. Disconnect the motor cable from the terminals U, V, and W and from the motor.
2. Measure the insulation resistance of the motor cable between phase conductors 1 and 2, between phase conductors 1 and 3, and between phase conductors 2 and 3.
3. Measure the insulation resistance between each phase conductor and the grounding conductor.
4. The insulation resistance must be  $>1 \text{ M}\Omega$  at the ambient temperature of  $20 \text{ }^\circ\text{C}$  ( $68 \text{ }^\circ\text{F}$ ).

#### The insulation checks of the mains cable

1. Disconnect the mains cable from the terminals L1, L2, and L3 and from mains.
2. Measure the insulation resistance of the mains cable between phase conductors 1 and 2, between phase conductors 1 and 3, and between phase conductors 2 and 3.
3. Measure the insulation resistance between each phase conductor and the grounding conductor.
4. The insulation resistance must be  $>1 \text{ M}\Omega$  at the ambient temperature of  $20 \text{ }^\circ\text{C}$  ( $68 \text{ }^\circ\text{F}$ ).

#### The insulation checks of the motor

1. Disconnect the motor cable from the motor.
2. Open the bridging connections in the motor connection box.
3. Measure the insulation resistance of each motor winding. The voltage must be the same or higher than the motor nominal voltage, but not higher than 1000 V.
4. The insulation resistance must be  $>1 \text{ M}\Omega$  at the ambient temperature of  $20 \text{ }^\circ\text{C}$  ( $68 \text{ }^\circ\text{F}$ ).
5. Obey the instructions of the motor manufacturer.

### 8.4 INSTALLATION IN AN IT SYSTEM

If your mains is impedance-grounded (IT), the AC drive must have the EMC protection level C4. If your drive has the EMC protection level C3, it is necessary to change it to C4. To do this, remove the EMC jumper.



**WARNING!**

Do not make changes in the AC drive when it is connected to mains. The components of the drive are live when the drive is connected to mains.

**CAUTION!**

Before you connect the AC drive to mains, make sure that the EMC level of the drive is correct. An incorrect EMC level can cause damage to the drive.

### 8.4.1 THE EMC JUMPER IN MR8

Change the EMC protection of the AC drive to level C4.

- 1 Open the cover of the AC drive.
- 2 Find the EMC box. To get access to the EMC jumper, remove the cover of the EMC box.

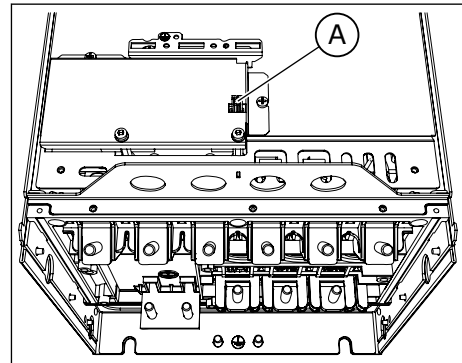

A. The EMC jumper

- 3 Remove the EMC jumper. Attach the cover of the EMC box again.

- 4 Find the grounding arm and push it down.

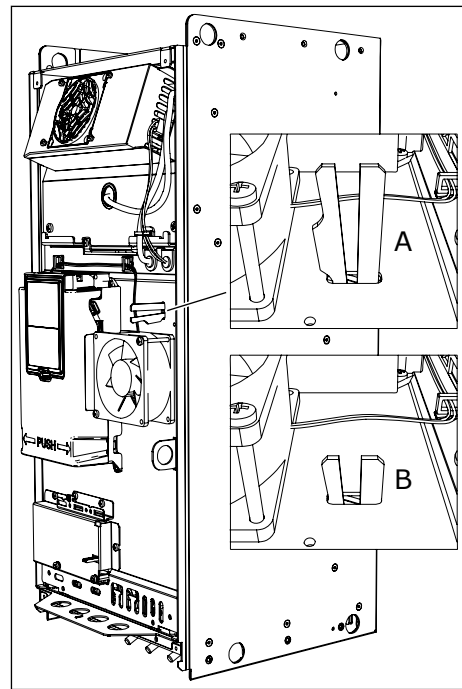

- A. The grounding arm is up
- B. The grounding arm is down (level C4)

- 5 After the change, write "The EMC level was changed" and the date on the "product modified" label. If the label is not attached at this time, attach it on the drive near the name plate.

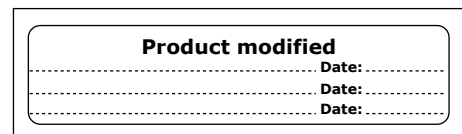

### 8.4.2 THE EMC JUMPER IN MR9

Change the EMC protection of the AC drive from level C3 to level C4.

#### THE EMC JUMPER 1

- 1 Open the cover of the AC drive.
- 2 Loosen the screws of the cover plate and remove it.

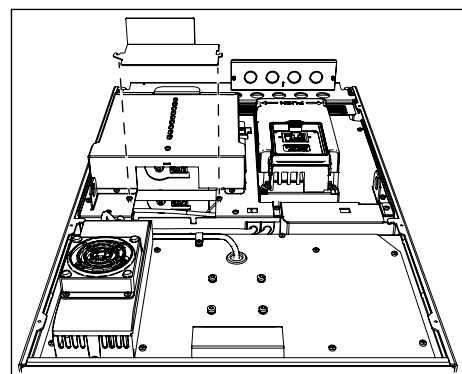

- 3 Remove the EMC jumper.

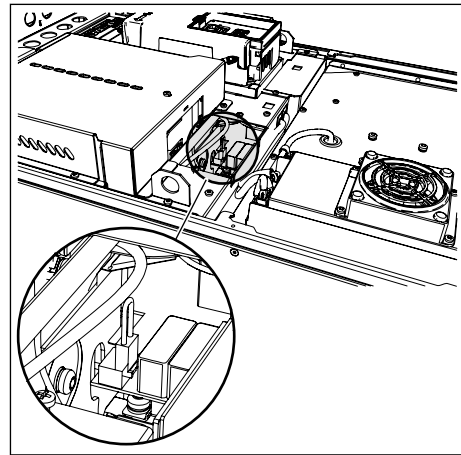

- 4 If you change the EMC level, write "The EMC level was changed" and the date on the "product changed" label. If the label is not attached at this time, attach it on the drive near the name plate.

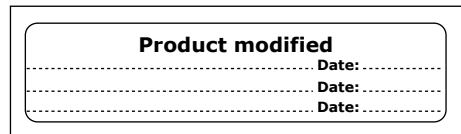

**THE EMC JUMPERS 2 AND 3**

- 1 Remove the cover of the extension box, the touch shield, and the I/O plate with the I/O grommet plate.
- 2 Find the 2 EMC jumpers on the EMC board. They are not adjacent to each other. Remove the EMC jumpers.

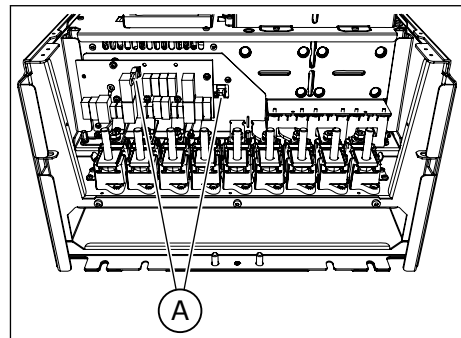

A. The EMC jumpers

- 3 If you change the EMC level, write "The EMC level was changed" and the date on the "product changed" label. If the label is not attached at this time, attach it on the drive near the name plate.

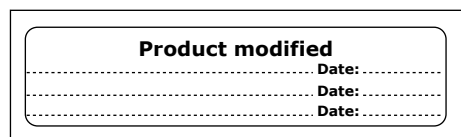

**8.4.3 THE EMC JUMPER IN MR10 AND MR12**

Change the EMC protection of the AC drive from level C3 to level C4. In MR12, the 2 power units must have the same EMC protection level.

**FINDING THE EMC JUMPER, WITHOUT THE OPTIONS MODULE**

- 1 Find the EMC jumper between the terminals L2 and L3.

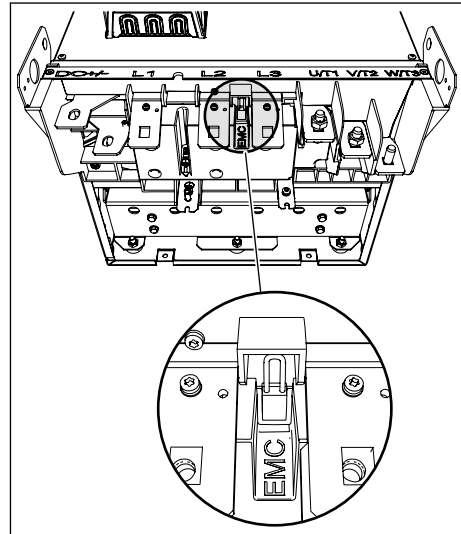

- 2 Remove the EMC jumper.

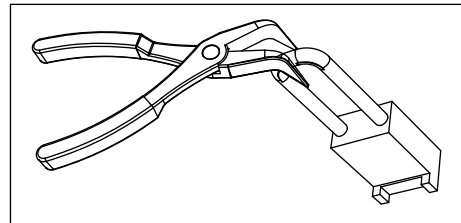

- 3 If you change the EMC level, write "The EMC level was changed" and the date on the "product modified" label. If the label is not attached at this time, attach it on the drive near the name plate.

<b>Product modified</b>	
.....	Date: .....
.....	Date: .....
.....	Date: .....

**FINDING THE EMC JUMPER, WITH AN OPTIONS MODULE**

- 1 Remove the covers of the options module.

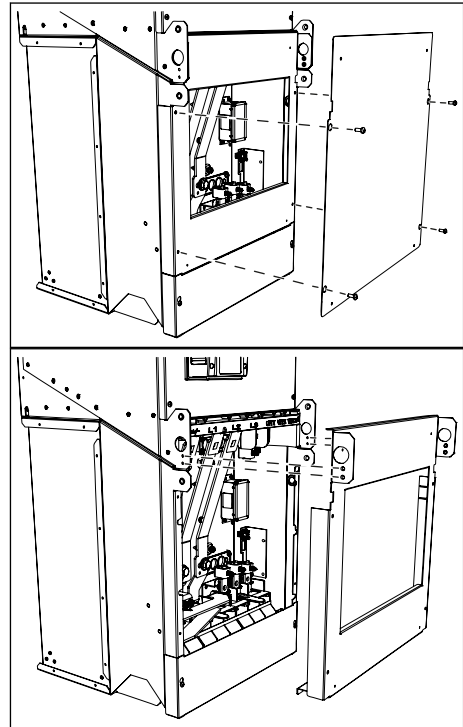

- 2 Find the EMC jumper between the terminals L2 and L3.

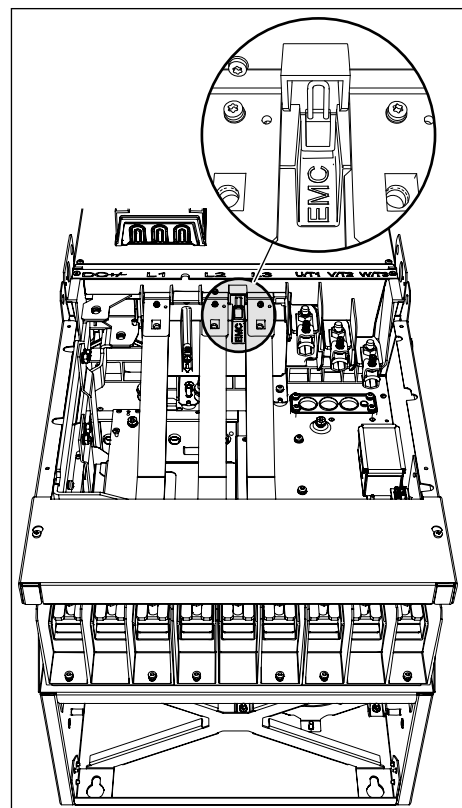

3 Remove the EMC jumper.

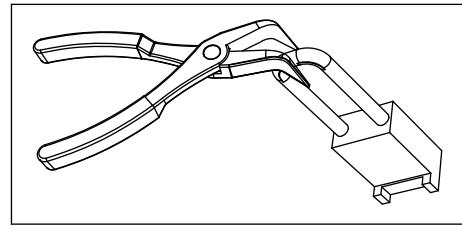

4 If you change the EMC level, write "The EMC level was changed" and the date on the "product modified" label. If the label is not attached at this time, attach it on the drive near the name plate.

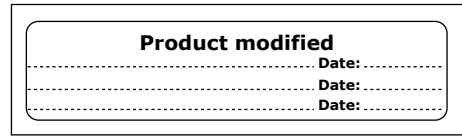

## 8.5 MAINTENANCE

### 8.5.1 MAINTENANCE INTERVALS

To make sure that the drive operates correctly and has a long life, we recommend that you do regular maintenance. Refer to *Table 30*.

It is not necessary to replace the main capacitors of the drive, because they are a thin film type capacitors.



**WARNING!**

Do not make changes in the AC drive when it is connected to mains. The components of the drive are live when the drive is connected to mains.

**Table 30: The maintenance intervals and tasks**

Maintenance interval	Maintenance task
Regularly	Do a check of the tightening torques of the terminals. Do a check of the filters.
6-24 months (The interval is different in different environments.)	Do a check of the mains and motor cable terminals and the control terminals. Make sure that the cooling fan operates correctly. Make sure that there is no corrosion on the terminals, the busbars or other surfaces. Do a check of the door filters of the cabinet. Do a check of the internal filter of the power unit.
24 months (The interval is different in different environments.)	Clean the heatsink and the cooling tunnel.
6-10 years	Replace the main fan. Replace the internal fans if the drive has them. Replace the fan power supply.
10 years	Replace the battery of the RTC. The battery is optional.

This table is valid for Vacon components. To do maintenance on components that are made by other manufacturers, obey the manual of the component in question.

## 8.5.2 REPLACING THE FANS OF THE AC DRIVE

### 8.5.2.1 Replacing the fans in MR8

Here are the instructions on how to replace the fans of the drive.

#### REPLACING THE FAN POWER SUPPLY, MR8

- 1 Remove the cover of the AC drive.
- 2 Disconnect the cables from the fan power supply.
  - a) Disconnect the fan supply cable from connector X81.
  - b) Disconnect the fan driver cable from connector X61.
  - c) Disconnect the DC supply cable from connector X8.

Remove the 4 screws that hold the fan power supply.

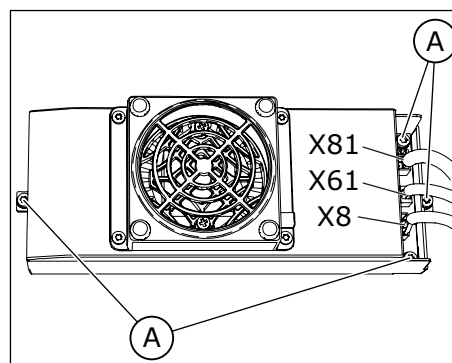

A. The 4 screws

- 3 Lift off the fan power supply.
- 4 Replace the fan power supply. Attach it with the screws.
- 5 Connect the cables and put the cover of the drive back.

#### REPLACING THE MAIN FAN, MR8

- 1 Remove the cover of the AC drive.
- 2 Remove the fan power supply. See the previous instructions.
- 3 Remove the 4 screws that hold the main fan unit. Lift off the main fan unit.

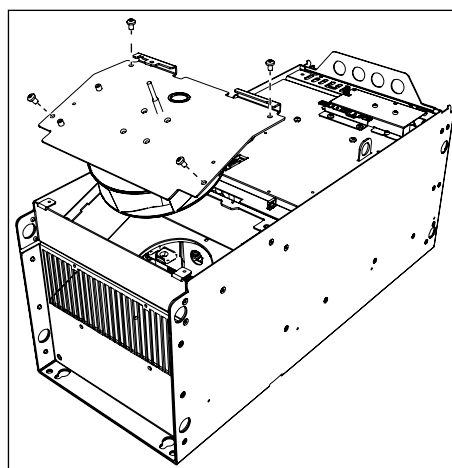

- 4 To release the fan from the cover plate, remove the 4 screws.

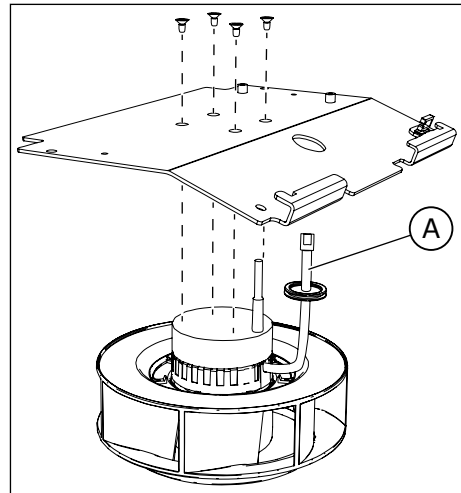

A. The fan cable

- 5 Release the grommet on the fan cable from the cover plate and pull out the cable.
- 6 Replace the main fan. Attach the screws.
- 7 Re-assemble the drive and connect the cables.

#### 8.5.2.2 Replacing the fans in MR9

Here are the instructions on how to replace the fans of the drive.

#### REPLACING THE FAN POWER SUPPLY, MR9

- 1 Remove the cover of the AC drive.
- 2 Disconnect the cables from the fan power supply.
  - a) Disconnect the fan supply cable from connector X81.
  - b) Disconnect the fan driver cable from connector X61.
  - c) Disconnect the DC supply cable from connector X8.

Remove the 4 screws that hold the fan power supply.

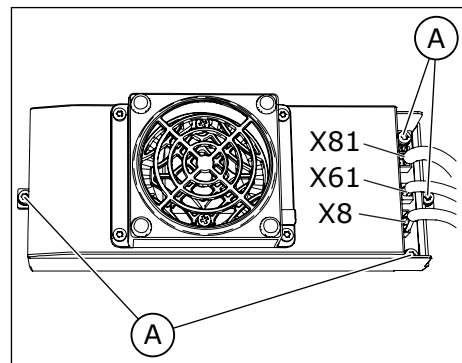

A. The 4 screws

- 3 Lift off the fan power supply.
- 4 Replace the fan power supply. Attach it with the screws.
- 5 Connect the cables and put the cover of the drive back.

#### REPLACING THE MAIN FAN, MR9

- 1 Remove the cover of the AC drive.



- 2 Disconnect the cables from the fan power supply.
- 3 Remove the 12 screws from the fan cover plate.  
Use the handle to lift off the main fan unit.

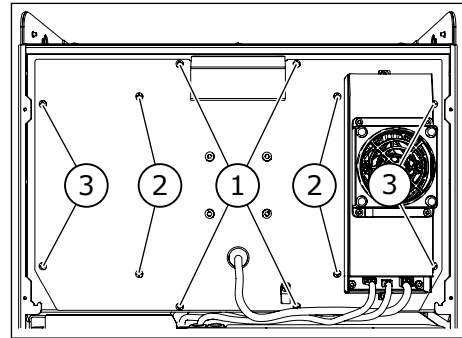

- 4 To release the fan from the cover plate, remove the 4 screws.

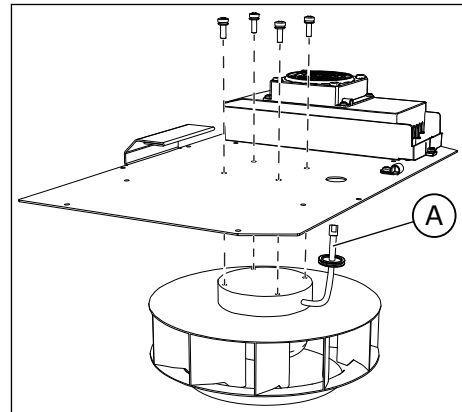

A. The fan cable

- 5 Release the grommet on the fan cable from the cover plate and pull out the cable.
- 6 Replace the main fan.
  - a) When you re-attach the main fan unit, make sure that the sealing tape under the fan plate is in good condition.
  - b) Attach the screws in the tightening order that is marked in the figure of the main fan unit (1 > 2 > 3).
- 7 Re-assemble the drive and connect the cables.

### 8.5.2.3 Replacing the fans in MR10 and MR12

Here are the instructions on how to replace the fans of the drive.

## REPLACING THE MAIN FAN ASSEMBLY, MR10 AND MR12

- 1 Loosen the 8 screws and lift off the service lid.

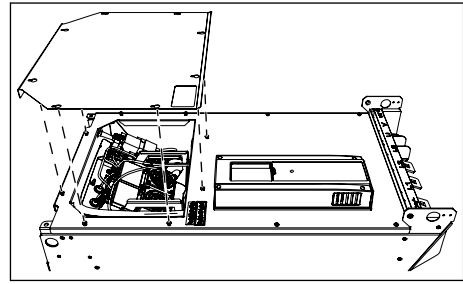

- 2 Disconnect the cables from each fan power supply.

- a) Disconnect the fan driver cable from connector X61.
- b) Disconnect the DC supply cable from connector X8.

Remove the 5 screws.

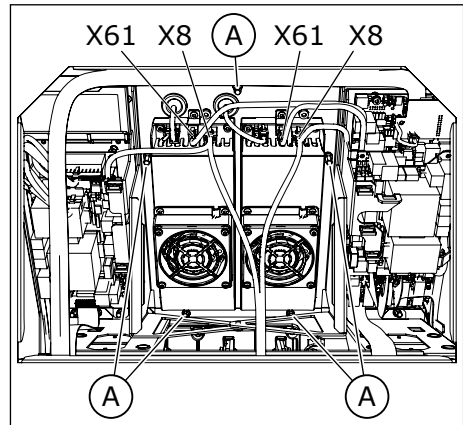

A. The 5 screws

- 3 Pull out the whole fan assembly. The assembly weighs approximately 11 kg.

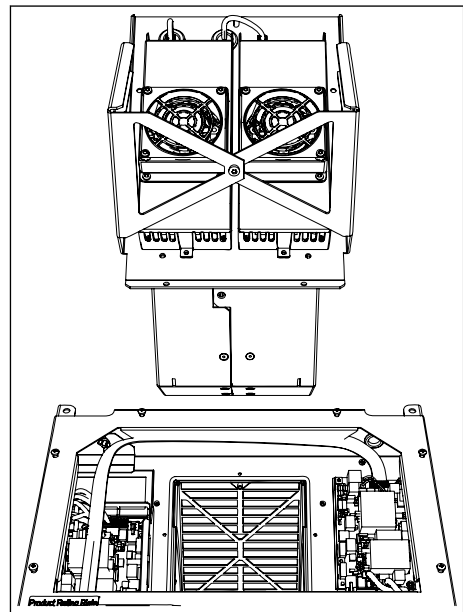

- 4 Replace the main fan assembly. Attach it with the screws.
- 5 Connect the cables and attach the service lid.

## REPLACING THE FAN POWER SUPPLIES, MR10 AND MR12

You can replace only 1 or both the fan power supplies.

- 1 Remove the main fan assembly. See the previous instructions.
- 2
  - a) Disconnect the fan supply cable from connector X81.
  - b) Disconnect the fan driver cable from connector X61.
  - c) Disconnect the DC supply cable from connector X8.

Remove the 4 screws from each supply.

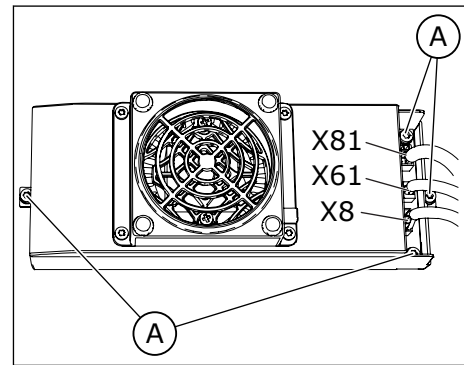

A. The 4 screws

- 3 Replace the fan power supplies.
- 4 Attach the screws, connect the cables, and re-assemble the drive.

### 8.5.3 DOWNLOADING THE SOFTWARE

When it is necessary to get a new version of the software of the drive, obey these instructions. For more information, speak to the manufacturer.

Before you start to download the software, read these warnings and the warnings in Chapter 2 *Safety*.



#### WARNING!

Do not touch the internal components or the circuit boards of the drive when the drive is connected to mains. These components are live. A contact with this voltage is very dangerous.



#### WARNING!

Do not make connections to or from the AC drive when it is connected to mains. There is a dangerous voltage.



#### WARNING!

To do work on the connections of the drive, disconnect the drive from mains. Wait 5 minutes before you open the cabinet door or the cover of the drive. Then use a measuring device to make sure that there is no voltage. The connections of the drive are live 5 minutes after it is disconnected from mains.



#### WARNING!

Before you do electrical work, make sure that there is no voltage.

## DOWNLOADING WITH MAINS, MR8-MR12

When the drive is supplied from mains, you can download a new software with the Vacon Loader PC tool and a CAB-USB/RS485 cable.

- 1 To download a new software, connect the PC into the control panel connector with the CAB-USB/RS485 cable.
  - The downloading time:
    - MR8 and MR9: approximately 6 minutes
    - MR10: approximately 12 minutes
    - MR12: approximately 25 minutes

When the drive is not supplied from mains, there are 2 alternatives to download the software.

1. The first is to use the Software Service Kit. The kit enables the power-up of the control board without the power-up of the drive, and enables you to download the software. Refer to the Software Service Kit User Manual for more information. In MR10 and MR12, you must also connect an external 24 VDC into the connector X50 on the measurement board.
2. The second alternative is to use an external 24 VDC power supply. Refer to the instructions below.

## DOWNLOADING WITHOUT MAINS, MR8-MR12

When the drive is not supplied from mains, use an external 24 VDC power supply to power-up to the control unit. In MR8 and MR9, the external 24 VDC does power up to the control unit, and in MR10 and MR12, it does power up to the control unit and the measurement board(s). After the power-up you can download the software.

The requirements for the 24 VDC power supply:

- A voltage accuracy +/-10%
  - MR8-MR9: > 1000 mA
  - MR10: > 2000 mA
  - MR12: > 4000 mA
- 1 In MR8 and MR9, connect an external 24 VDC power supply into the control terminals 13 and 30. Connect the external GND potential into terminal 13, and the external 24 VDC (+) potential into terminal 30. See the terminals in *Fig. 18* and *Fig. 19*.

- 2 In MR10 and MR12, loosen the screws of the service lid and remove it.
  - In MR12, there are two power units. Do the steps 2 and 3 for the two power units.
  
- 3 In MR10 and MR12, connect an external 24 VDC into the connector X50 on the measurement board. The connector pins are X50-22 (+) and X50-23 (-).
  - In MR12, connect the external 24 VDC to the two X50 connectors.

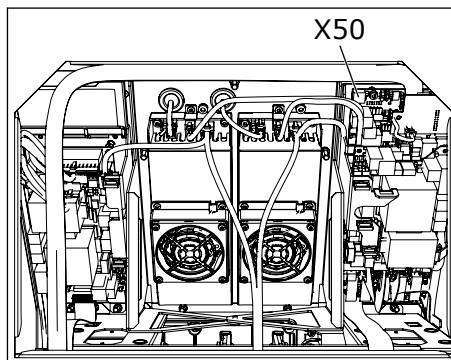
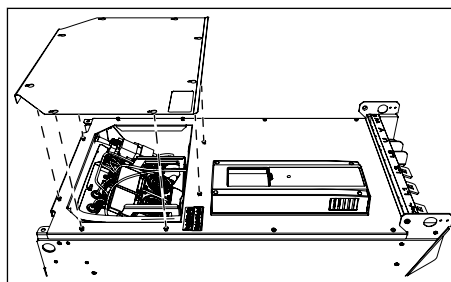
**NOTE!**

The size of the power supply wire for the external 24 VDC must be a minimum of 1 mm<sup>2</sup>. The length of the wire from the 24 VDC power supply to the X50 connectors and to the control unit connectors must be a maximum of 3 m (9.84 ft).

- 4 In all the enclosure sizes, do power-up to the external 24 VDC power supply.
- 5 Remove the control panel. Connect the PC to the control panel connector in the control unit with an CAB-USB/RS485 cable.
- 6 Start the Vacon Loader PC tool.
- 7 Start the downloading of the software.
- 8 After the downloading is complete, disconnect the PC and attach the control panel into the control unit.
- 9 Do power-down to the external 24 VDC power supply.
- 10 In MR8 and MR9, remove the external 24 VDC power supply wires from the terminals. (Unless the control unit of the drive is normally supplied with an external 24 VDC supply.)
- 11 In MR10 and MR12, remove the external 24 VDC wires from the X50 connector of the measurement board. In MR12, there are two X50 connectors.
- 12 In MR10 and MR12, attach the service lid. In MR12, there are two service lids.
- 13 After the downloading procedure is complete, start the Startup wizard (see the Application Manual).

**WARNING!**

Before you connect the drive to mains, make sure that the front cover and the cable cover of the drive are closed. The connections of the AC drive are live when the drive is connected to mains.

# 9 TECHNICAL DATA, VACON® 100

## 9.1 AC DRIVE POWER RATINGS

### 9.1.1 MAINS VOLTAGE 208-240 V

**Table 31: The power ratings of Vacon® 100 in mains voltage 208-240 V, 50-60 Hz, 3~**

Enclosure size	Drive type	Loadability							Motor shaft power			
		Low			High			Max current Is 2s	230 V mains		230 V mains	
		Continuous current I <sub>Lout</sub> [A]	Input current I <sub>Lin</sub> [A]	10% overload current [A]	Continuous current I <sub>Hout</sub> [A]	Input current I <sub>Hin</sub> [A]	50% overload current [A]		10% overload 40°C [kW]	50% overload 40°C [kW]	10% overload 40°C [hp]	50% overload 40°C [hp]
MR8	0140	140.0	135.1	154.0	114.0	109.0	171.0	210.0	37.0	30.0	50.0	40.0
	0170	170.0	162.0	187.0	140.0	133.0	210.0	280.0	45.0	37.0	60.0	50.0
	0205	205.0	200.0	225.5	170.0	163.0	255.0	340.0	55.0	45.0	75.0	60.0
MR9	0261	261.0	253.0	287.1	211.0	210.0	316.5	410.0	75.0	55.0	100.0	75.0
	0310	310.0	301.0	341.0	251.0	246.0	376.5	502.0	90.0	75.0	125.0	100.0

## 9.1.2 MAINS VOLTAGE 380-500 V

Table 32: The power ratings of Vacon® 100 in mains voltage 380-500V, 50-60 Hz, 3~

Enclosure size	Drive type	Loadability							Motor shaft power			
		Low			High			Max current I <sub>s</sub> 2s	400 V mains		480 V mains	
		Continuous current I <sub>Lout</sub> [A]	Input current I <sub>Lin</sub> [A]	10% overload current [A]	Continuous current I <sub>Hout</sub> [A]	Input current I <sub>Hin</sub> [A]	50% overload current [A]		10% overload 40°C [kW]	50% overload 40°C [kW]	10% overload 40°C [hp]	50% overload 40°C [hp]
MR8	0140	140.0	139.4	154.0	105.0	109.0	157.5	210.0	75.0	44.0	100.0	75.0
	0170	170.0	166.5	187.0	140.0	139.4	210.0	280.0	90.0	75.0	125.0	100.0
	0205	205.0	199.6	225.5	170.0	166.5	255.0	340.0	110.0	90.0	150.0	125.0
MR9	0261	261.0	258.0	287.1	205.0	204.0	307.5	410.0	132.0	110.0	200.0	150.0
	0310	310.0	303.0	341.0	251.0	246.0	376.5	502.0	160.0	132.0	250.0	200.0
MR10	0385	385.0	385.0	423.5	310.0	311.0	465.0	620.0	200.0	160.0	300.0	250.0
	0460	460.0	460.0	506.0	385.0	391.0	577.5	770.0	250.0	200.0	350.0	300.0
	0520	520.0	520.0	572.0	460.0	459.0	690.0	920.0	250.0	250.0	450.0	350.0
	0590*	590.0	590.0	649.0	520.0	515.0	780.0	1040.0	315.0	250.0	500.0	450.0
MR12	0650	650.0	648.0	715.0	590.0	587.0	885.0	1180.0	355.0	315.0	500.0	500.0
	0730	730.0	724.0	803.0	650.0	642.0	975.0	1300.0	400.0	355.0	600.0	500.0
	0820	820.0	822.0	902.0	730.0	731.0	1095.0	1460.0	450.0	400.0	700.0	600.0
	0920	920.0	916.0	1012.0	820.0	815.0	1230.0	1640.0	500.0	450.0	800.0	700.0
	1040*	1040.0	1030.0	1144.0	920.0	908.0	1380.0	1840.0	560.0	500.0	900.0	800.0
	1180*	1180.0	1164.0	1298.0	920.0	908.0	1380.0	1840.0	630.0	500.0	1000.0	800.0

\* = The maximum ambient temperature is 35°C with the du/dt filter option.



9.1.3 MAINS VOLTAGE 525-690 V

Table 33: The power ratings of Vacon® 100 in mains voltage 525-690 V, 50-60 Hz, 3~

Enclosure size	Drive type	Loadability							Motor shaft power			
		Low			High			Max current Is 2s	600 V mains		690 V mains	
		Continuous current I <sub>Lout</sub> [A]	Input current I <sub>Lin</sub> [A]	10% overload current [A]	Continuous current I <sub>Hout</sub> [A]	Input current I <sub>Hin</sub> [A]	50% overload current [A]		10% overload 40°C [Hp]	50% overload 40°C [Hp]	10% overload 40°C [kW]	50% overload 40°C [kW]
MR8	0080	80.0	90.0	88.0	62.0	72.0	93.0	124.0	75.0	60.0	75.0	55.0
	0100	100.0	106.0	110.0	80.0	89.0	120.0	160.0	100.0	75.0	90.0	75.0
	0125	125.0	127.0	137.5	100.0	104.0	150.0	200.0	125.0	100.0	110.0	90.0
MR9	0144	144.0	156.0	158.4	125.0	140.0	187.5	250.0	150.0	125.0	132.0	110.0
	0170	170.0	179.0	187.0	144.0	155.0	216.0	288.0	-	-	160.0	132.0
	0208	208.0	212.0	228.8	170.0	177.0	255.0	340.0	200.0	150.0	200.0	160.0
MR10	0261	261.0	272.0	287.1	208.0	223.0	312.0	416.0	250.0	200.0	250.0	200.0
	0325	325.0	330.0	357.5	261.0	269.0	391.5	522.0	300.0	250.0	315.0	250.0
	0385	385.0	386.0	423.5	325.0	327.0	487.5	650.0	400.0	300.0	355.0	315.0
	0416*	416.0	415.0	457.6	385.0	382.0	577.5	770.0	450.0	300.0	400.0	355.0
MR12	0460	460.0	477.0	506.0	416.0	433.0	624.0	832.0	450.0	400.0	450.0	400.0
	0520	520.0	532.0	572.0	460.0	472.0	690.0	920.0	500.0	450.0	500.0	450.0
	0590	590.0	597.0	649.0	520.0	527.0	780.0	1040.0	600.0	500.0	560.0	500.0
	0650	650.0	653.0	715.0	590.0	591.0	885.0	1180.0	650.0	600.0	630.0	560.0
	0750*	750.0	747.0	825.0	650.0	646.0	975.0	1300.0	700.0	650.0	710.0	630.0
	0820*	820.0	813.0	902.0	650.0	739.0	975.0	1300.0	800.0	650.0	800.0	630.0

\* = The maximum ambient temperature is 35°C with the du/dt filter option.

9.1.4 OVERLOAD CAPABILITY

The **low overload** means that if 110% of the continuous current (I<sub>L</sub>) is necessary for 1 minute each 10 minutes, the remaining 9 minutes must be approximately 98% of I<sub>L</sub> or less. This is to make sure that the output current is not more than I<sub>L</sub> during the duty cycle.

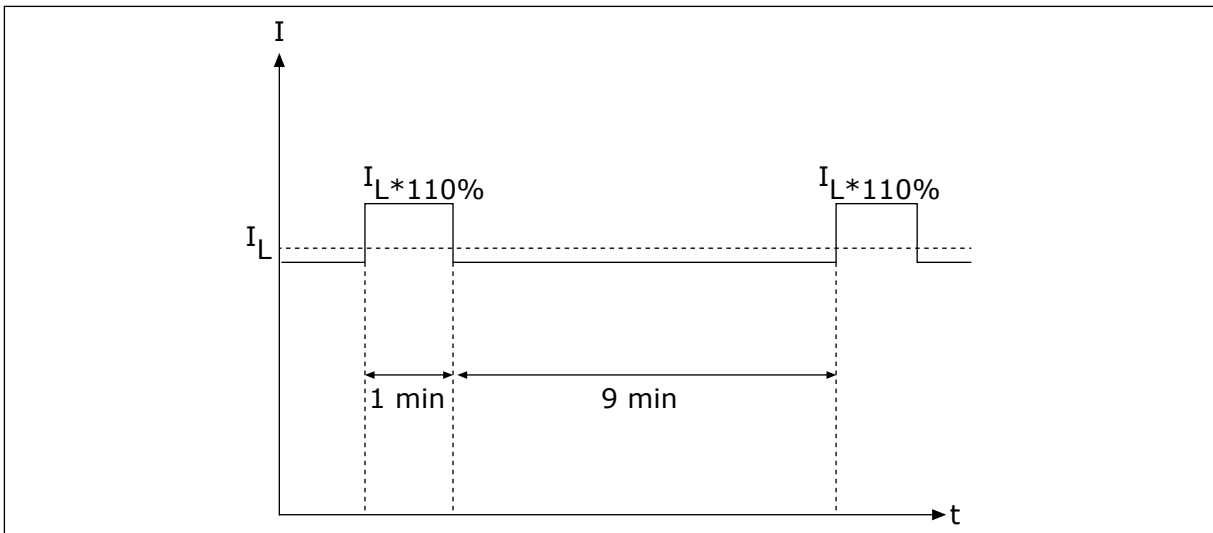

Fig. 26: Low overload

The **high overload** means that if 150% of the continuous current ( $I_H$ ) is necessary for 1 minute each 10 minutes, the remaining 9 minutes must be approximately 92% of  $I_H$  or less. This is to make sure that the output current is not more than  $I_H$  during the duty cycle.

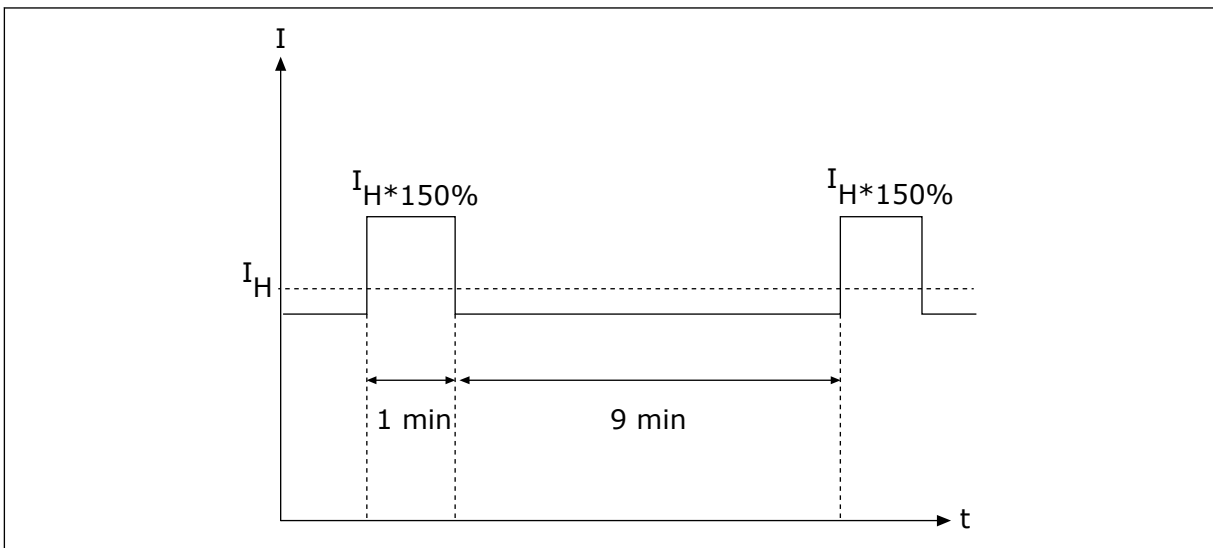

Fig. 27: High overload

For more information, refer to the standard IEC61800-2 (IEC:1998).

### 9.1.5 BRAKE RESISTOR RATINGS

Make sure that the resistance is higher than the set minimum resistance. The power handling capacity must be sufficient for the application.

**Table 34: The recommended brake resistor types and the calculated resistance of the drive, 208-240 V**

Enclosure size	Duty cycle	Type of brake resistor	Resistance [ $\Omega$ ]
MR8	Light duty	BRR 0105 LD 5	6.5
	Heavy duty	BRR 0105 HD 5	6.5
MR9	Light duty	BRR 0300 LD 5	3.3
	Heavy duty	BRR 0300 HD 5	3.3

**Table 35: The recommended brake resistor types and the calculated resistance of the drive, 380-500 V**

Enclosure size	Duty cycle	Type of brake resistor	Resistance [ $\Omega$ ]
MR8	Light duty	BRR 0105 LD 5	6.5
	Heavy duty	BRR 0105 HD 5	6.5
MR9	Light duty	BRR 0300 LD 5	3.3
	Heavy duty	BRR 0300 HD 5	3.3
MR10	Light duty	BRR 0520 LD 5	1.4
	Heavy duty	BRR 0520 HD 5	1.4
MR12	Light duty	BRR 0520 LD 5	2 x 1.4
	Heavy duty	BRR 0520 LD 5	2 x 1.4

**Table 36: The recommended brake resistor types and the calculated resistance of the drive, 525-690 V**

Enclosure size	Drive type	Duty cycle	Type of brake resistor	Resistance [ $\Omega$ ]
MR8	0080	Light duty	BRR 0052 LD 6	18
		Heavy duty	BRR 0052 HD 6	18
	0100-0125	Light duty	BRR 0100 LD 6	9
		Heavy duty	BRR 0100 HD 6	9
MR9	0144	Light duty	BRR 0100 LD 6	9
		Heavy duty	BRR 0100 HD 6	9
	0170-0208	Light duty	BRR 0208 LD 6	7
		Heavy duty	BRR 0208 HD 6	7
MR10	0261-0416	Light duty	BRR 0416 LD 6	2.5
		Heavy duty	BRR 0416 HD 6	2.5
MR12	0460-0820	Light duty	BRR 0416 LD 6	2 x 2.5
		Heavy duty	BRR 0416 HD 6	2 x 2.5

The enclosure size MR12 includes 2 power units, each of which has a brake chopper. The brake choppers must have their own brake resistors. See the main circuit diagram in 5.1.3 *General information about the installation, MR12.*

- The light duty cycle is for brake resistor cyclic use (1 LD pulse in a 120-second period). The light duty resistor is rated for a 5-second ramp from full power to 0.
- The heavy duty cycle is for brake resistor cyclic use (1 HD pulse in a 120-second period). The heavy duty resistor is rated for a 3-second full power braking with a 7-second ramp to 0.

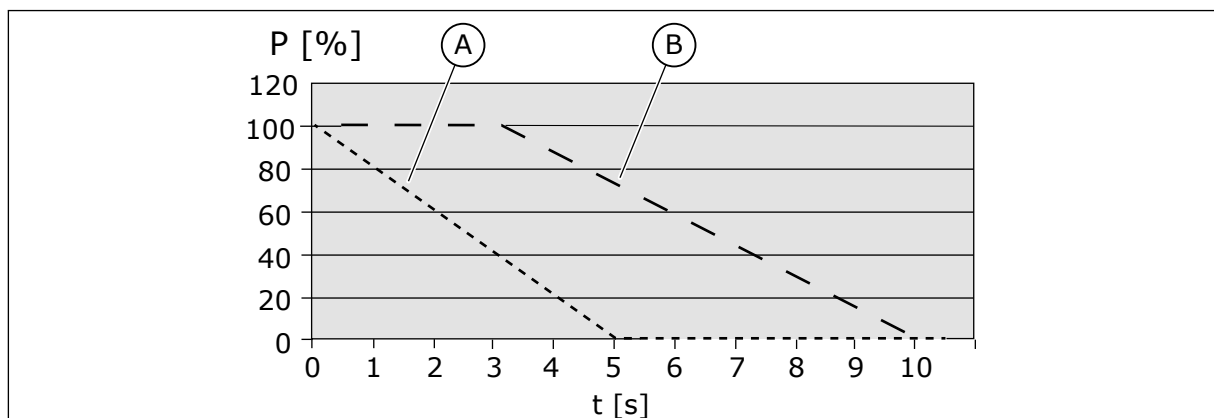

Fig. 28: The LD and HD pulses

A. Light duty

B. Heavy duty

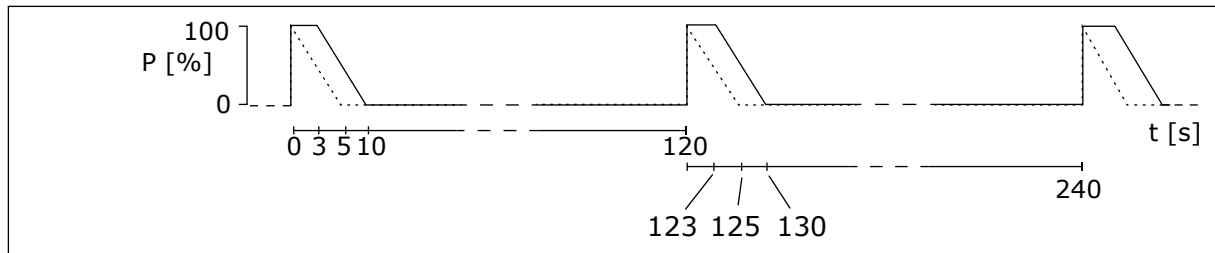

Fig. 29: The duty cycles of the LD and HD pulses

**Table 37: The minimum resistance and the brake power, mains voltage 208-240 V**

Enclosure size	The minimum brake resistance [ $\Omega$ ]	Brake power* @845 VDC [kW]
MR8	3.0	25.2
MR9	1.4	49.7

**Table 38: The minimum resistance and the brake power, mains voltage 380-500 V**

Enclosure size	The minimum brake resistance [ $\Omega$ ]	Brake power* @845 VDC [kW]
MR8	6.5	109.9
MR9	3.3	216.4
MR10	1.4	400
MR12	2 x 1.4 **	800

**Table 39: The minimum resistance and the brake power, mains voltage 525-690 V**

Enclosure size	The minimum brake resistance [ $\Omega$ ]	Brake power* @1166 VDC [kW]
MR8	9	110
MR9	7	193
MR10	2.5	400
MR12	2 x 2.5 **	800

\* = When you use recommended resistor types.

\*\* = The MR12 must have 2 brake resistors.

## 9.2 VACON® 100 - TECHNICAL DATA

**Table 40: The technical data of the Vacon® 100 AC drive**

Technical item or function		Technical data
Mains connection	Input voltage $U_{in}$	208-240 V, 380-500 V, 525-690 V, -10%...+10%
	Input frequency	50-60 Hz, -5...+10%
	Connection to mains	Once per minute or less frequently
	Starting delay	8 s (MR8 to MR12)
	Mains	<ul style="list-style-type: none"> <li>Mains types: TN, TT, and IT</li> <li>Short circuit current: the maximum short circuit current must be &lt; <math>I_{cc}</math> 65 kA.</li> </ul>
Motor connection	Output voltage	0- $U_{in}$
	Continuous output current	IL: Ambient temperature max. +40 °C overload 1.1 x IL (1 min/10 min) IH: Ambient temperature max. +40 °C overload 1.5 x IH (1 min/10 min) IH in 690 V drives: Ambient temperature max. +40 °C overload 1.5 x IH (1 min/10 min)
	Output frequency	0-320 Hz (standard)
	Frequency resolution	0.01 Hz

**Table 40: The technical data of the Vacon® 100 AC drive**

Technical item or function	Technical data
Control characteristics	<p>Switching frequency (see parameter P3.1.2.3)</p> <p><b>200-500 V</b></p> <ul style="list-style-type: none"> <li>• MR8-MR12:                             <ul style="list-style-type: none"> <li>• 1.5-6 kHz</li> <li>• Default: MR8: 3 kHz, MR9: 2 kHz, MR10: 2 kHz, MR12: 2 kHz</li> </ul> </li> </ul> <p><b>690 V</b></p> <ul style="list-style-type: none"> <li>• MR8-MR12:                             <ul style="list-style-type: none"> <li>• 1.5-6 kHz</li> <li>• Default: 2 kHz</li> <li>• For a product that is configured for a C4 installation on IT network the maximum switching frequency is limited to default 2kHz.</li> </ul> </li> </ul> <p>Automatic switching frequency derating in case of overload.</p>
Frequency reference: Analogue input Panel reference	Resolution 0.1% (10-bit), accuracy ±1% Resolution 0.01 Hz
Field weakening point	8-320 Hz
Acceleration time	0.1-3000 s
Deceleration time	0.1-3000 s

**Table 40: The technical data of the Vacon® 100 AC drive**

Technical item or function		Technical data
Ambient conditions	Ambient operating temperature	IL current: -10°C (no frost)...+40 °C IH current: -10°C (no frost)...+40 °C Maximum operating temperature: +50 °C with derating (1.5%/1°C)
	Storage temperature	-40 °C...+70 °C
	Relative humidity	0-95% RH, non-condensing, non-corrosive
	Air quality	Tested according to IEC 60068-2-60 Test Ke: Flowing mixed gas corrosion test, Method 1 (H <sub>2</sub> S [hydrogen sulfide] and SO <sub>2</sub> [sulfur dioxide]) Designed according to <ul style="list-style-type: none"> <li>• Chemical vapours: IEC 60721-3-3, unit in operation, class 3C2</li> <li>• Mechanical particles: IEC 60721-3-3, unit in operation, class 3S2</li> </ul>
	Altitude	100% load capacity (no derating) up to 1000 m 1% derating for each 100m above 1000 m Maximum altitudes: <ul style="list-style-type: none"> <li>• 208-240 V: 4000 m (TN and IT systems)</li> <li>• 380-500 V: 4000 m (TN and IT systems)</li> <li>• 380-500 V: 2000 m (corner-grounded network)</li> <li>• 525-690 V: 2000 m (TN and IT systems, no corner grounding)</li> </ul> Voltage for relay outputs: <ul style="list-style-type: none"> <li>• Up to 3000 m : Allowed up to 240 V</li> <li>• 3000-4000 m: Allowed up to 120 V</li> </ul> Corner-grounding: <ul style="list-style-type: none"> <li>• up to 2000 m only (Requires a change in the EMC level from C3 to C4, see 8.4 Installation in an IT system.)</li> </ul>
Pollution degree	PD2	
Ambient conditions	Vibration: EN61800-5-1 EN60068-2-6	5-150 Hz Displacement amplitude 0.25 mm (peak) at 5-31 Hz Maximum acceleration amplitude 1 G at 31-150 Hz
	Shock: EN60068-2-27	UPS Drop Test (for applicable UPS weights) Storage and shipping: maximum 15 G, 11 ms (in package)
	Enclosure class	IP00 / UL Open Type



**Table 40: The technical data of the Vacon® 100 AC drive**

Technical item or function		Technical data
EMC (at default settings)	Immunity	Fulfils EN61800-3, 1st and 2nd environment
	Emissions	<ul style="list-style-type: none"> <li>200-690 V: EN 61800-3 (2004), category C3, if the drive is correctly installed.</li> <li>The drive can be changed to C4 for IT type mains. See chapter 8.4 <i>Installation in an IT system</i>. The IP00 / UL Open Type drive has by default category C4.</li> </ul>
Noise level	Average noise level (min-max) sound pressure level in dB(A)	<p>The sound pressure depends on the cooling fan speed, which is controlled in accordance with the drive temperature.</p> <p>MR8: 58-73 MR9: 54-75 MR10/MR12: 58-75</p>
Safety		EN 61800-5-1, CE (See the nameplate of the drive for more approvals.)

**Table 40: The technical data of the Vacon® 100 AC drive**

Technical item or function	Technical data
Protections	Overvoltage trip limit Mains voltage 240 V: 456 VDC Mains voltage 500 V: 911 VDC Mains voltage 690 V: 1258 VDC
	Undervoltage trip limit Depends on mains voltage (0.8775 x mains voltage): Mains voltage 240 V: trip limit 211 VDC Mains voltage 400 V: trip limit 351 VDC Mains voltage 500 V: trip limit 438 VDC Mains voltage 525 V: trip limit 461 VDC Mains voltage 690 V: trip limit 606 VDC
	Earth fault protection Yes
	Mains supervision Yes
	Motor phase supervision Yes
	Overcurrent protection Yes
	Unit overtemperature protection Yes
	Motor overload protection Yes. The motor overload protection activates at 110% of the full load current.
	Motor stall protection Yes
	Motor underload protection Yes
	Short-circuit protection of +24 V and +10 V reference voltages Yes

# 10 TECHNICAL DATA, VACON® 100 FLOW

## 10.1 AC DRIVE POWER RATINGS

### 10.1.1 MAINS VOLTAGE 208-240 V

**Table 41: The power ratings of Vacon® 100 FLOW in mains voltage 208-240 V, 50-60 Hz, 3~**

Enclosure size	Drive type	Loadability				Motor shaft power	
		Continuous current I <sub>Lout</sub> [A]	Input current I <sub>Lin</sub> [A]	10% overload current [A]	Max current I <sub>S</sub> 2s	230 V mains	230 V mains
						10% overload 40°C [kW]	10% overload 40°C [hp]
MR8	0140	143.0	135.1	154.0	210.0	37.0	50.0
	0170	170.0	162.0	187.0	280.0	45.0	60.0
	0205	208.0	200.0	225.5	340.0	55.0	75.0
MR9	0261	261.0	253.0	287.1	410.0	75.0	100.0
	0310	310.0	301.0	341.0	502.0	90.0	125.0

## 10.1.2 MAINS VOLTAGE 380-500 V

**Table 42: The power ratings of Vacon® 100 FLOW in mains voltage 380-500 V, 50-60 Hz, 3~**

Enclosure size	Drive type	Loadability				Motor shaft power	
		Continuous current $I_{Lout}$ [A]	Input current $I_{Lin}$ [A]	10% overload current [A]	Max current $I_S$ 2s	400 V mains	480 V mains
						10% overload 40°C [kW]	10% overload 40°C [hp]
MR8	0140	140.0	139.4	154.0	210.0	75.0	100.0
	0170	170.0	166.5	187.0	280.0	90.0	125.0
	0205	205.0	199.6	225.5	340.0	110.0	150.0
MR9	0261	261.0	258.0	287.1	410.0	132.0	200.0
	0310	310.0	303.0	341.0	502.0	160.0	250.0
MR10	0385	385.0	385.0	423.5	620.0	200.0	300.0
	0460	460.0	460.0	506.0	770.0	250.0	350.0
	0520	520.0	520.0	572.0	920.0	250.0	450.0
	0590*	590.0	590.0	649.0	1040.0	315.0	500.0
MR12	0650	650.0	648.0	715.0	1180.0	355.0	500.0
	0730	730.0	724.0	803.0	1300.0	400.0	600.0
	0820	820.0	822.0	902.0	1460.0	450.0	700.0
	0920	920.0	916.0	1012.0	1640.0	500.0	800.0
	1040*	1040.0	1030.0	1144.0	1840.0	560.0	900.0
	1180*	1180.0	1164.0	1298.0	1840.0	630.0	1000.0

\* = The maximum ambient temperature is 35°C with the du/dt filter option.

## 10.1.3 MAINS VOLTAGE 525-690 V

**Table 43: The power ratings of Vacon® 100 FLOW in mains voltage 525-690 V, 50-60 Hz, 3~**

Enclosure size	Drive type	Loadability				Motor shaft power	
		Continuous current $I_{Lout}$ [A]	Input current $I_{Lin}$ [A]	10% overload current [A]	Max current $I_S$ 2s	600 V mains	690 V mains
						10% overload 40°C [hp]	10% overload 40°C [kW]
MR8	0080	80.0	90.0	88.0	124.0	75.0	75.0
	0100	100.0	106.0	110.0	160.0	100.0	90.0
	0125	125.0	127.0	137.5	200.0	125.0	110.0
MR9	0144	144.0	156.0	158.4	250.0	150.0	132.0
	0170	170.0	179.0	187.0	288.0	-	160.0
	0208	208.0	212.0	228.8	340.0	200.0	200.0
MR10	0261	261.0	272.0	287.1	416.0	250.0	250.0
	0325	325.0	330.0	357.5	522.0	300.0	315.0
	0385	385.0	386.0	423.5	650.0	400.0	355.0
	0416*	416.0	415.0	457.6	770.0	450.0	400.0
MR12	0460	460.0	477.0	506.0	832.0	450.0	450.0
	0520	520.0	532.0	572.0	920.0	500.0	500.0
	0590	590.0	597.0	649.0	1040.0	600.0	560.0
	0650	650.0	653.0	715.0	1180.0	650.0	630.0
	0750*	750.0	747.0	825.0	1300.0	700.0	710.0
	0820*	820.0	813.0	902.0	1300.0	800.0	800.0

\* = The maximum ambient temperature is 35°C with the du/dt filter option.

## 10.1.4 OVERLOAD CAPABILITY

The **low overload** means that if 110% of the continuous current ( $I_L$ ) is required for 1 minute every 10 minutes, the remaining 9 minutes must be approximately 98% of  $I_L$  or less. This is to make sure that the output current is not more than  $I_L$  during the duty cycle.

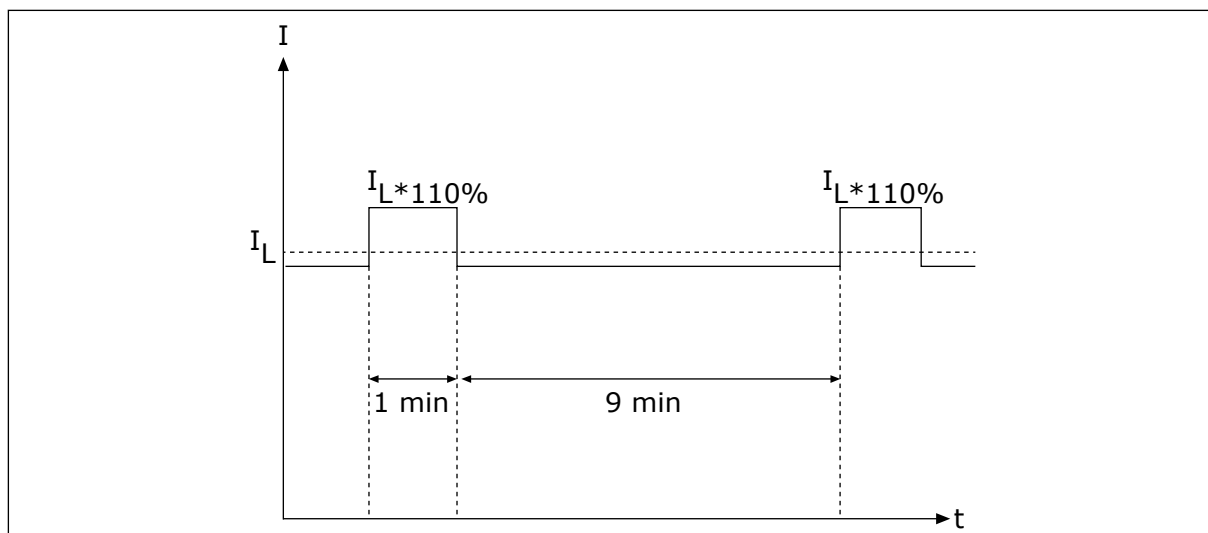

Fig. 30: Low overload in Vacon® 100 FLOW

For more information, refer to the standard IEC61800-2 (IEC:1998).

## 10.2 VACON® 100 FLOW - TECHNICAL DATA

**Table 44: The technical data of the Vacon® 100 FLOW AC drive**

Technical item or function		Technical data
Mains connection	Input voltage $U_{in}$	208-240 V, 380-500 V, 525-690 V, -10%...+10%
	Input frequency	50-60 Hz, -5...+10%
	Connection to mains	Once per minute or less frequently
	Starting delay	8 s (MR8 to MR12)
	Mains	<ul style="list-style-type: none"> <li>• Mains types: TN, TT, and IT</li> <li>• Short circuit current: the maximum short circuit current must be &lt; <math>I_{cc}</math> 65 kA.</li> </ul>
Motor connection	Output voltage	0- $U_{in}$
	Continuous output current	$I_L$ : Ambient temperature max. +40 °C overload 1.1 x $I_L$ (1 min/10 min)
	Output frequency	0-320 Hz (standard)
	Frequency resolution	0.01 Hz

**Table 44: The technical data of the Vacon® 100 FLOW AC drive**

Technical item or function	Technical data
Control qualities	<p>Switching frequency (see parameter P3.1.2.3)</p> <p><b>200-500 V</b></p> <ul style="list-style-type: none"> <li>• MR8-MR12: <ul style="list-style-type: none"> <li>• 1.5-6 kHz</li> <li>• Default: MR8: 3 kHz, MR9: 2 kHz, MR10: 2 kHz, MR12: 2 kHz</li> </ul> </li> </ul> <p><b>690 V</b></p> <ul style="list-style-type: none"> <li>• MR8-MR12: <ul style="list-style-type: none"> <li>• 1.5-6 kHz</li> <li>• Default: 2 kHz</li> <li>• For a product that is configured for a C4 installation on IT network the maximum switching frequency is limited to default 2kHz.</li> </ul> </li> </ul> <p>Automatic switching frequency derating in case of overload.</p>
Frequency reference: Analogue input Panel reference	Resolution 0.1% (10-bit), accuracy ±1% Resolution 0.01 Hz
Field weakening point	8-320 Hz
Acceleration time	0.1-3000 s
Deceleration time	0.1-3000 s



**Table 44: The technical data of the Vacon® 100 FLOW AC drive**

Technical item or function	Technical data
Ambient conditions	Ambient operating temperature IL current: -10°C (no frost)...+40 °C Maximum operating temperature: +50 °C with derating (1.5%/1°C)
	Storage temperature -40 °C...+70 °C
	Relative humidity 0-95% RH, non-condensing, non-corrosive
	Air quality Tested according to IEC 60068-2-60 Test Ke: Flowing mixed gas corrosion test, Method 1 (H <sub>2</sub> S [hydrogen sulfide] and SO <sub>2</sub> [sulfur dioxide]) Designed according to <ul style="list-style-type: none"> <li>• Chemical vapours: IEC 60721-3-3, unit in operation, class 3C2</li> <li>• Mechanical particles: IEC 60721-3-3, unit in operation, class 3S2</li> </ul>
	Altitude 100% load capacity (no derating) up to 1000 m 1-% derating for each 100m above 1000 m Maximum altitudes: <ul style="list-style-type: none"> <li>• 208-240 V: 4000 m (TN and IT systems)</li> <li>• 380-500 V: 4000 m (TN and IT systems)</li> <li>• 380-500 V: 2000 m (corner-grounded network)</li> <li>• 525-690 V: 2000 m (TN and IT systems, no corner grounding)</li> </ul> Voltage for relay outputs: <ul style="list-style-type: none"> <li>• Up to 3000 m : Allowed up to 240 V</li> <li>• 3000-4000 m: Allowed up to 120 V</li> </ul> Corner-grounding: <ul style="list-style-type: none"> <li>• up to 2000 m only (Requires a change in the EMC level from C3 to C4, see 8.4 <i>Installation in an IT system.</i>)</li> </ul>
Pollution degree	PD2
Ambient conditions	Vibration: EN61800-5-1 EN60068-2-6 5-150 Hz Displacement amplitude 0.25 mm (peak) at 5-31 Hz Maximum acceleration amplitude 1 G at 31-150 Hz
	Shock: EN60068-2-27 UPS Drop Test (for applicable UPS weights) Storage and shipping: maximum 15 G, 11 ms (in package)
	Enclosure class

**Table 44: The technical data of the Vacon® 100 FLOW AC drive**

Technical item or function		Technical data
EMC (at default settings)	Immunity	Fulfils EN61800-3, 1st and 2nd environment
	Emissions	<ul style="list-style-type: none"> <li>• 200-690 V: EN 61800-3 (2004), category C3, if the drive is correctly installed.</li> <li>• The drive can be changed to C4 for IT type mains. See chapter 8.4 <i>Installation in an IT system</i>. The IP00 / UL Open Type drive has by default category C4.</li> </ul>
Noise level	Average noise level (min-max) sound pressure level in dB(A)	<p>The sound pressure depends on the cooling fan speed, which is controlled in accordance with the drive temperature.</p> <p>MR8: 58-73 MR9: 54-75 MR10/MR12: 58-75</p>
Safety		EN 61800-5-1, CE (See the nameplate of the drive for more approvals.)

**Table 44: The technical data of the Vacon® 100 FLOW AC drive**

Technical item or function		Technical data
Protections	Overvoltage trip limit	Mains voltage 240 V: 456 VDC Mains voltage 500 V: 911 VDC Mains voltage 690 V: 1258 VDC
	Undervoltage trip limit	Depends on mains voltage (0.8775 x mains voltage):  Mains voltage 240 V: trip limit 211 VDC Mains voltage 400 V: trip limit 351 VDC Mains voltage 500 V: trip limit 438 VDC Mains voltage 525 V: trip limit 461 VDC Mains voltage 690 V: trip limit 606 VDC
	Earth fault protection	Yes
	Mains supervision	Yes
	Motor phase supervision	Yes
	Overcurrent protection	Yes
	Unit overtemperature protection	Yes
	Motor overload protection	Yes. The motor overload protection activates at 110% of the full load current.
	Motor stall protection	Yes
	Motor underload protection	Yes
	Short-circuit protection of +24 V and +10 V reference voltages	Yes

# 11 TECHNICAL DATA ON CONTROL CONNECTIONS

## 11.1 TECHNICAL DATA ON CONTROL CONNECTIONS

**Table 45: The standard I/O board**

Standard I/O board		
Terminal	Signal	Technical information
1	Reference output	+10 V, +3%, maximum current: 10 mA
2	Analogue input, voltage or current	Analogue input channel 1 0...+10 V ( $R_i = 200 \text{ k}\Omega$ ) 4-20 mA ( $R_i = 250 \text{ }\Omega$ ) Resolution 0.1 %, accuracy $\pm 1 \%$ Selection V/mA with DIP switches (see chapter Selection of terminal functions with DIP switches in the Installation Manual).
3	Analogue input common (current)	Differential input if not connected to ground Allows $\pm 20 \text{ V}$ common mode voltage to GND
4	Analogue input, voltage or current	Analogue input channel 2 Default: 4-20 mA ( $R_i = 250 \text{ }\Omega$ ) 0-10 V ( $R_i = 200 \text{ k}\Omega$ ) Resolution 0.1 %, accuracy $\pm 1 \%$ Selection V/mA with DIP switches (see chapter Selection of terminal functions with DIP switches in the Installation Manual)
5	Analogue input common (current)	Differential input if not connected to ground Allows $\pm 20 \text{ V}$ common mode voltage to GND
6	24 V aux. voltage	+24 V, $\pm 10\%$ , max volt. ripple < 100 mVrms max. 250 mA Short-circuit protected
7	I/O ground	Ground for reference and controls (connected internally to frame ground through 1 M $\Omega$ )
8	Digital input 1	Positive or negative logic $R_i = \text{min. } 5 \text{ k}\Omega$ 0-5 V = 0 15-30 V = 1
9	Digital input 2	
10	Digital input 3	

**Table 45: The standard I/O board**

Standard I/O board		
Terminal	Signal	Technical information
11	Common A for DIN1-DIN6	Digital inputs can be disconnected from ground, see chapter Isolation of digital inputs from ground in the Installation Manual.
12	24 V aux. voltage	+24 V, ±10%, max volt. ripple < 100mVrms max. 250 mA Short-circuit protected
13	I/O ground	Ground for reference and controls (connected internally to frame ground through 1 MΩ)
14	Digital input 4	Positive or negative logic R <sub>i</sub> = min. 5 kΩ 0-5 V = 0 15-30 V = 1
15	Digital input 5	
16	Digital input 6	
17	Common A for DIN1-DIN6	Digital inputs can be isolated from ground, see chapter Isolation of digital inputs from ground in the Installation Manual.
18	Analogue signal (+output)	Analogue output channel 1, selection 0 -20 mA, load <500 Ω Default: 0-20 mA 0-10 V Resolution 0.1 %, accuracy ±2 % Selection V/mA with DIP switches (see chapter Selection of terminal functions with DIP switches in the Installation Manual) Short-circuit protected
19	Analogue output common	
30	24V auxiliary input voltage	Can be used as external power backup for the control unit
A	RS485	Differential receiver/transmitter Set bus termination with DIP switches (see chapter Selection of terminal functions with DIP switches in the Installation Manual). Termination resistance = 220 Ω
B	RS485	

**Table 46: The standard relay board (+SBF3)**

Terminal	Signal	Technical information
21	Relay output 1 *	Change-over contact (SPDT) relay. 5.5 mm isolation between channels. Switching capacity <ul style="list-style-type: none"> <li>• 24 VDC/8 A</li> <li>• 250 VAC/8 A</li> <li>• 125 VDC/0.4 A</li> </ul> Minimum switching load <ul style="list-style-type: none"> <li>• 5 V/10 mA</li> </ul>
22		
23		
24	Relay output 2 *	Change-over contact (SPDT) relay. 5.5 mm isolation between channels. Switching capacity <ul style="list-style-type: none"> <li>• 24 VDC/8 A</li> <li>• 250 VAC/8 A</li> <li>• 125 VDC/0.4 A</li> </ul> Minimum switching load <ul style="list-style-type: none"> <li>• 5 V/10 mA</li> </ul>
25		
26		
32	Relay output 3 *	Normally-open (NO or SPST) contact relay. 5.5 mm isolation between channels. Switching capacity <ul style="list-style-type: none"> <li>• 24 VDC/8 A</li> <li>• 250 VAC/8 A</li> <li>• 125 VDC/0.4 A</li> </ul> Minimum switching load <ul style="list-style-type: none"> <li>• 5 V/10 mA</li> </ul>
33		

\* = If you use 230 VAC as control voltage from the output relays, the control circuitry must be powered with a separate isolation transformer to limit the short circuit current and the overvoltage spikes. This is to prevent welding on the relay contacts. Refer to standard EN 60204-1, section 7.2.9.

**Table 47: The optional relay board (+SBF4)**

Terminal	Signal	Technical information
21	Relay output 1 *	Change-over contact (SPDT) relay. 5.5 mm isolation between channels. Switching capacity <ul style="list-style-type: none"> <li>• 24 VDC/8 A</li> <li>• 250 VAC/8 A</li> <li>• 125 VDC/0.4 A</li> </ul> Minimum switching load <ul style="list-style-type: none"> <li>• 5 V/10 mA</li> </ul>
22		
23		
24	Relay output 2 *	Change-over contact (SPDT) relay. 5.5 mm isolation between channels. Switching capacity <ul style="list-style-type: none"> <li>• 24 VDC/8 A</li> <li>• 250 VAC/8 A</li> <li>• 125 VDC/0.4 A</li> </ul> Minimum switching load <ul style="list-style-type: none"> <li>• 5 V/10 mA</li> </ul>
25		
26		
28	T11+ T11-	Thermistor input Rtrip = 4.7 kΩ (PTC) Measuring voltage 3.5V
29		

\* = If you use 230 VAC as control voltage from the output relays, the control circuitry must be powered with a separate isolation transformer to limit the short circuit current and the overvoltage spikes. This is to prevent welding on the relay contacts. Refer to standard EN 60204-1, section 7.2.9.

# VACON<sup>®</sup>

[www.danfoss.com](http://www.danfoss.com)

Vacon Ltd  
Member of the Danfoss Group  
Runsorintie 7  
65380 Vaasa  
Finland

Document ID:



Rev. C

Sales code: DOC-INS100IP00+DLUK