

VACON[®] 100 INDUSTRIAL
VACON[®] 100 FLOW
VACON[®] 100 HVAC
VACON[®] 100 X
AC DRIVES

MODBUS TCP / MODBUS RTU
USER MANUAL

VACON[®]

TABLE OF CONTENTS

Document: DPD00156C
Version release date: 5.2.16

1. Safety	2
1.1 Danger.....	2
1.2 Warnings.....	3
1.3 Earthing and earth fault protection.....	4
2. Modbus - general info	5
3. Modbus technical data	7
3.1 Modbus RTU protocol.....	7
3.2 Modbus TCP protocol.....	7
3.3 Cable length.....	7
4. Installation	8
4.1 Installation in Vacon® 100.....	8
4.1.1 Prepare for use through ethernet.....	9
4.1.2 Prepare for use through RS485.....	11
4.2 Installation in Vacon® 100 X.....	15
4.2.1 Prepare for use through Ethernet.....	15
4.2.2 Prepare for use through RS485.....	16
5. Programming	18
5.1 Modbus RS-485 parameters and monitoring values.....	19
5.2 Modbus TCP parameters and monitoring values.....	20
5.2.1 Ethernet common settings.....	20
5.2.2 Modbus TCP settings.....	20
5.3 Modbus RTU parameter descriptions.....	22
5.3.1 Modbus RTU Parameters.....	22
5.3.2 Modbus RTU monitoring values.....	22
5.4 Modbus TCP parameter descriptions.....	25
5.4.1 Ethernet common settings.....	25
5.4.2 Modbus TCP settings.....	25
5.4.3 Modbus TCP monitoring values.....	26
6. Communications	28
6.1 Data addresses in Modbus messages.....	28
6.2 Supported Modbus Functions.....	28
6.3 Modbus data mapping.....	30
6.3.1 Coils registers.....	30
6.3.2 Discrete inputs.....	30
6.3.3 Holding registers and input registers.....	30
6.4 Example messages.....	40
7. Fault tracing	45
7.1 Typical fault conditions.....	45
7.2 RS-485 bus biasing.....	45
7.3 Other fault conditions.....	46
8. Quick setup	48
9. Annex	49



1. SAFETY

This manual contains clearly marked cautions and warnings which are intended for your personal safety and to avoid any unintentional damage to the product or connected appliances.

Please read the information included in cautions and warnings carefully.

The cautions and warnings are marked as follows:

Table 1. Warning signs

	= DANGER! Dangerous voltage
	= WARNING or CAUTION
	= Caution! Hot surface

1.1 DANGER



The **components of the power unit are live** when the drive is connected to mains potential. Coming into contact with this voltage is **extremely dangerous** and may cause death or severe injury.



The **motor terminals U, V, W and the brake resistor terminals are live** when the AC drive is connected to mains, even if the motor is not running.



After disconnecting the AC drive from the mains, **wait** until the indicators on the keypad go out (if no keypad is attached see the indicators on the cover). Wait 5 more minutes before doing any work on the connections of the drive. Do not open the cover before this time has expired. After expiration of this time, use a measuring equipment to absolutely ensure that no voltage is present. **Always ensure absence of voltage before starting any electrical work!**



The control I/O-terminals are isolated from the mains potential. However, the **relay outputs and other I/O-terminals may have a dangerous control voltage** present even when the AC drive is disconnected from mains.



Before connecting the AC drive to mains make sure that the front and cable covers of the drive are closed.



During a ramp stop (see the Application Manual), the motor is still generating voltage to the drive. Therefore, do not touch the components of the AC drive before the motor has completely stopped. Wait until the indicators on the keypad go out (if no keypad is attached see the indicators on the cover). Wait additional 5 minutes before starting any work on the drive.

1.2 WARNINGS



The AC drive is meant for **fixed installations only**.



Do not perform any measurements when the AC drive is connected to the mains.



The **earth leakage current** of the AC drives exceeds 3.5mA AC. According to standard EN61800-5-1, **a reinforced protective ground connection** must be ensured. See chapter 1.3.



If the AC drive is used as a part of a machine, the **machine manufacturer is responsible** for providing the machine with a **supply disconnecting device** (EN 60204-1).



Only **spare parts** delivered by Vacon can be used.



At power-up, power brake or fault reset **the motor will start immediately** if the start signal is active, unless the pulse control for Start/Stop logic has been selected. Furthermore, the I/O functionalities (including start inputs) may change if parameters, applications or software are changed. Disconnect, therefore, the motor if an unexpected start can cause danger.



The **motor starts automatically** after automatic fault reset if the auto restart function is activated. See the Application Manual for more detailed information.



Prior to measurements on the motor or the motor cable, disconnect the motor cable from the AC drive.



Do not touch the components on the circuit boards. Static voltage discharge may damage the components.



Check that the **EMC level** of the AC drive corresponds to the requirements of your supply network.

1.3 EARTHING AND EARTH FAULT PROTECTION



CAUTION!

The AC drive must always be earthed with an earthing conductor connected to the earthing terminal marked with

The earth leakage current of the drive exceeds 3.5mA AC. According to EN61800-5-1, one or more of the following conditions for the associated protective circuit shall be satisfied:

- b) The protective conductor shall have a cross-sectional area of at least 10 mm² Cu or 16 mm² Al, through its total run.
- c) Where the protective conductor has a cross-sectional area of less than 10 mm² Cu or 16 mm² Al, a second protective conductor of at least the same cross-sectional area shall be provided up to a point where the protective conductor has a cross-sectional area not less than 10 mm² Cu or 16 mm² Al.
- d) Automatic disconnection of the supply in case of loss of continuity of the protective conductor.

The cross-sectional area of every protective earthing conductor which does not form part of the supply cable or cable enclosure shall, in any case, be not less than:

- 2.5mm² if mechanical protection is provided or
- 4mm² if mechanical protection is not provided.

The earth fault protection inside the AC drive protects only the drive itself against earth faults in the motor or the motor cable. It is not intended for personal safety.

Due to the high capacitive currents present in the AC drive, fault current protective switches may not function properly.



Do not perform any voltage withstand tests on any part of the AC drive. There is a certain procedure according to which the tests shall be performed. Ignoring this procedure may result in damaged product.

NOTE! You can download the English and French product manuals with applicable safety, warning and caution information from <http://drives.danfoss.com/knowledge-center/technical-documentation/>.

REMARQUE Vous pouvez télécharger les versions anglaise et française des manuels produit contenant l'ensemble des informations de sécurité, avertissements et mises en garde applicables sur le site <http://drives.danfoss.com/knowledge-center/technical-documentation/>.

.

2. MODBUS - GENERAL INFO

Modbus is a communication protocol developed by Modicon systems. In simple terms, it is a way of sending information between electronic devices. The device requesting the information is called the Modbus Master (or the Client in Modbus TCP) and the devices supplying information are Modbus Slaves (in Modbus TCP servers). In a standard Modbus network, there is one Master and up to 247 Slaves, each with a unique Slave Address from 1 to 247. The Master can also write information to the Slaves. Modbus is typically used to transmit signals from instrumentation and control devices back to a main controller or data gathering system.

The Modbus communication interface is built around messages. The format of these Modbus messages is independent of the type of physical interface used. The same protocol can be used regardless of the connection type. Because of this, Modbus gives the possibility to easily upgrade the hardware structure of an industrial network, without the need for large changes in the software. A device can also communicate with several Modbus nodes at once, even if they are connected with different interface types, without the need to use a different protocol for every connection.

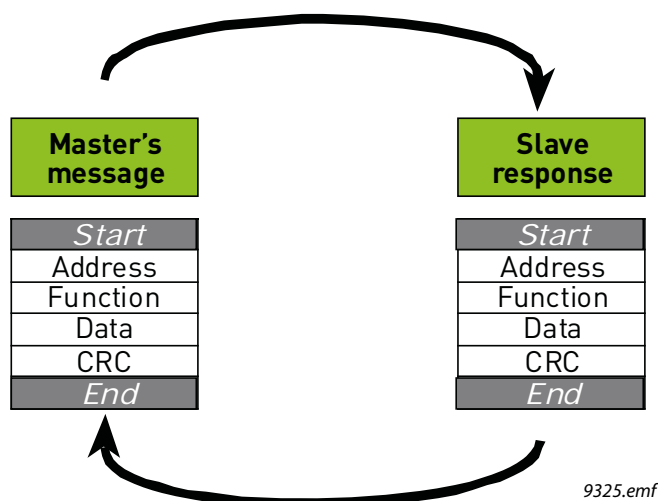

Figure 1. Basic structure of Modbus frame

On simple interfaces like RS485, the Modbus messages are sent in plain form over the network. In this case the network is dedicated to Modbus. When using more versatile network systems like TCP/IP over Ethernet, the Modbus messages are embedded in packets with the format necessary for the physical interface. In that case Modbus and other types of connections can co-exist at the same physical interface at the same time. Although the main Modbus message structure is peer-to-peer, Modbus is able to function on both point-to-point and multidrop networks.

Each Modbus message has the same structure. Four basic elements are present in each message. The sequence of these elements is the same for all messages, to make it easy to parse the content of the Modbus message. A conversation is always started by a master in the Modbus network. A Modbus master sends a message and—depending of the contents of the message—a slave takes action and responds to it. There can be more masters in a Modbus network. Addressing in the message header is used to define which device should respond to a message. All other nodes on the Modbus network ignore the message if the address field does not match their own address.

Your Vacon[®] 100 drive is equipped with Modbus support as standard.

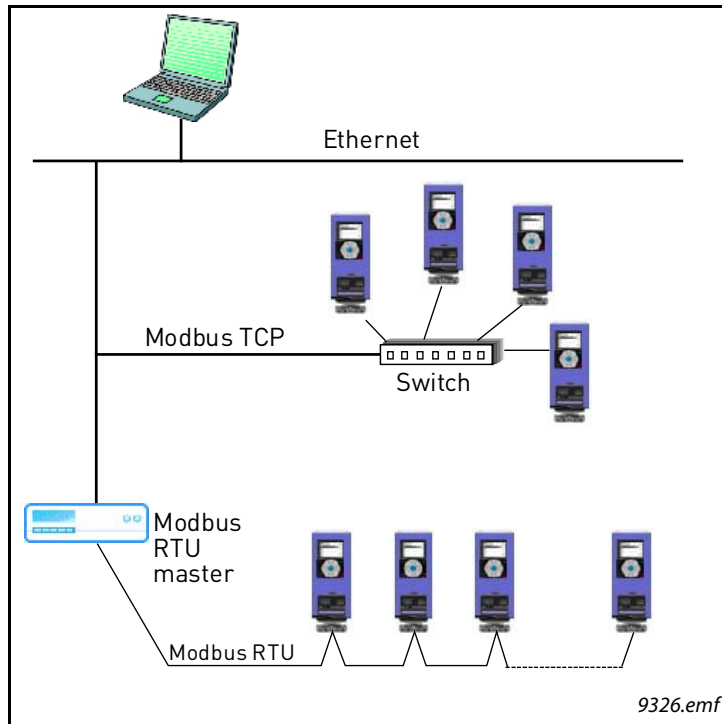

Figure 2. Principal example diagram of Modbus

If you need to contact Vacon service in problems related to Modbus, send a description of the problem together with the *Drive Info File* to ServiceSupportVDF@vacon.com.

3. MODBUS TECHNICAL DATA

3.1 MODBUS RTU PROTOCOL

Table 2.

Connections and communications	Interface	RS-485
	Data transfer method	RS-485 MS/TP, half-duplex
	Transfer cable	STP (Shielded Twisted Pair), type Belden 9841 or similar
	Connector	2.5 mm ²
	Electrical isolation	Functional
	Modbus RTU	As described in "Modicon Modbus Protocol Reference Guide"
	Bitrate	300, 600, 1200, 2400, 4800, 9600, 19200, 38400, 57600, 76800, 115200 and 230400 bits/s
	Addresses	1 to 247

3.2 MODBUS TCP PROTOCOL

Table 3.

Connections and communications	Interface	100BaseTX, IEEE 802.3 compatible
	Data transfer method	Ethernet half/full -duplex
	Data transfer speed	10/100 MBit/s, autosensing
	Protocol	Modbus TCP
	Connector	Shielded RJ45 connector
	Cable type	CAT5e STP
	Modbus TCP	As described in Modbus Messaging Implementation Guide
	Default IP	Selectable: Fixed or DHCP (AutoIP)

3.3 CABLE LENGTH

The maximum allowed length of a single CAT5 Ethernet cable is 100 meters.

The maximum length of an RS-485 cable depends on the bitrate used, the cable (gauge, capacitance or characteristic impedance) and the number of devices in the bus. The Modbus RTU specification states that the maximum cable length is 1000 meters when using max 9600 bits/second bitrate and AWG26 or wider gauge cable. The actual cable length which can be used in an installation can be lower than this number depending on the aforementioned parameters.

4. INSTALLATION

4.1 INSTALLATION IN VACON® 100

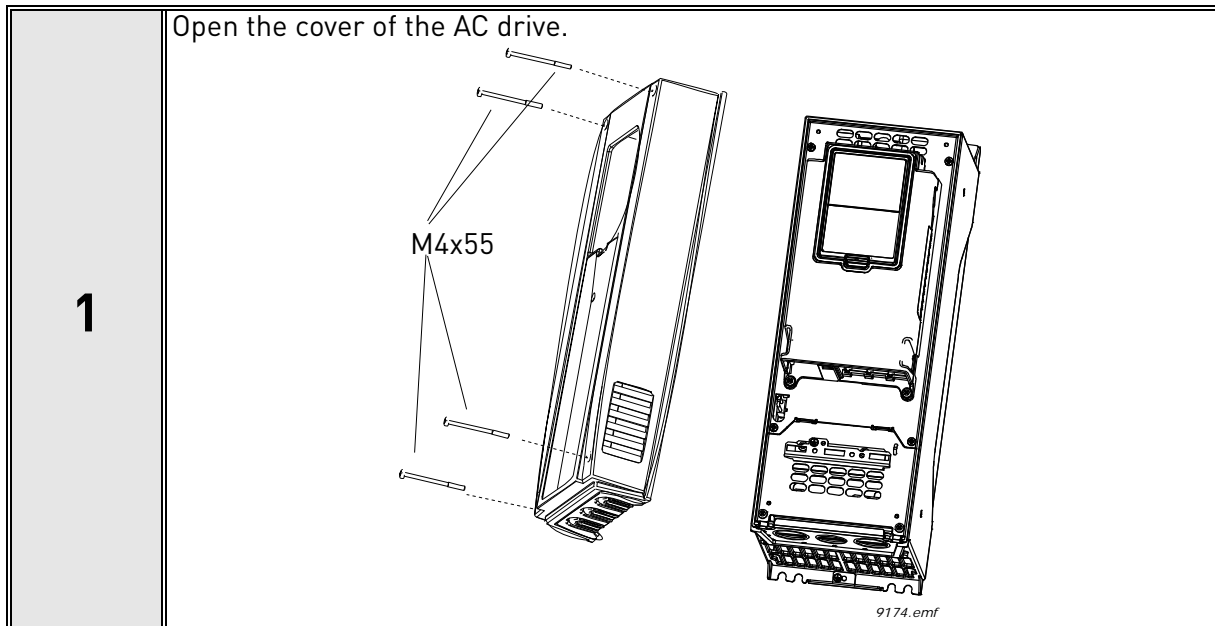

The relay outputs and other I/O-terminals may have a dangerous control voltage present even when the AC drive is disconnected from mains.

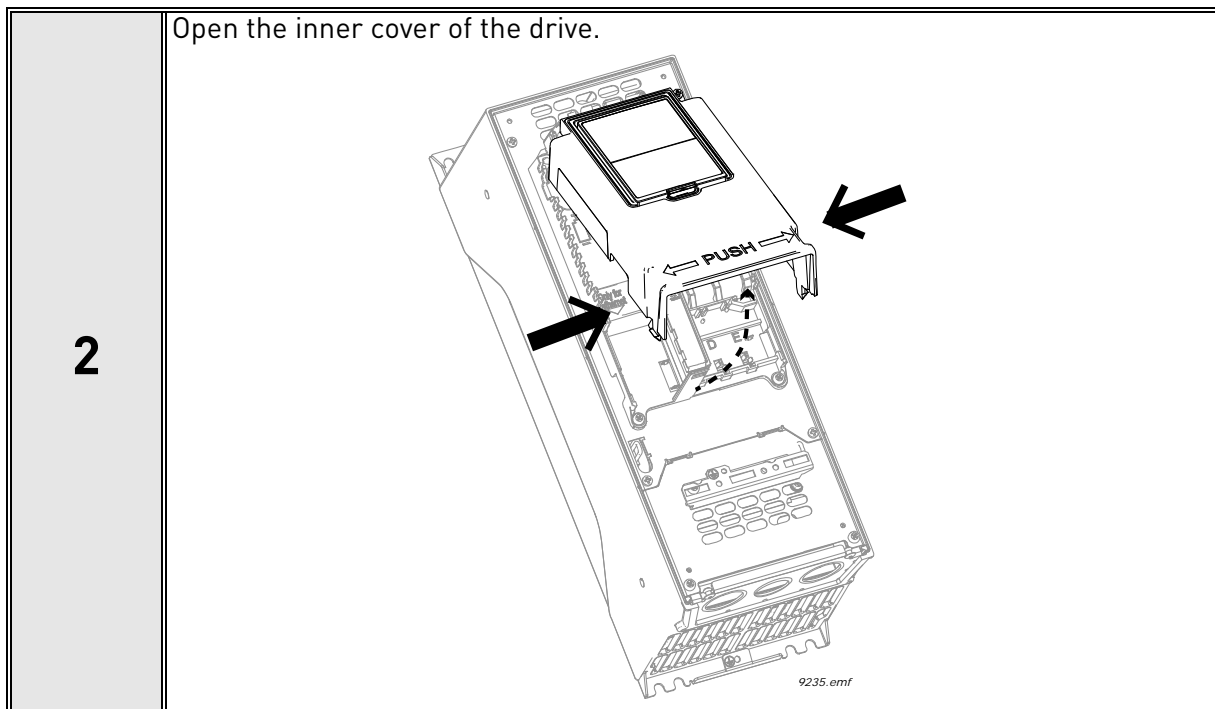

4.1.1 PREPARE FOR USE THROUGH ETHERNET

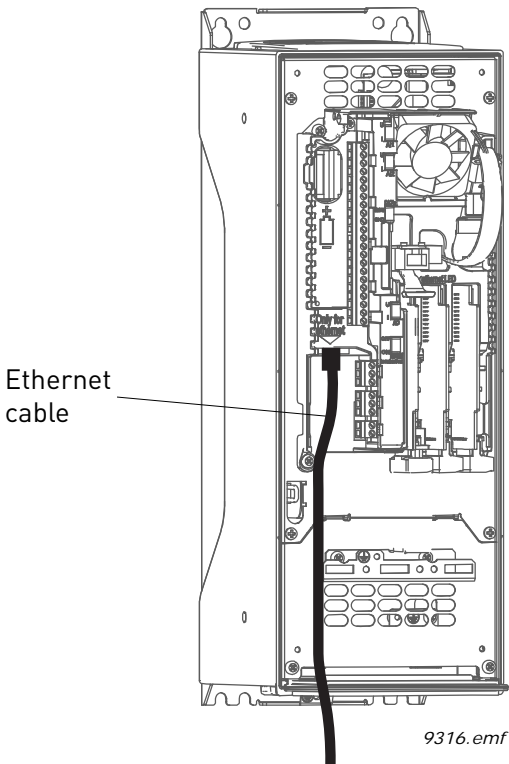
3	<p>Connect the Ethernet cable (see specification in Chapter 3.2) to its terminal as shown in figure below.</p>  <p>The diagram shows a side view of a VACON drive cabinet with its front door open. An Ethernet cable is plugged into the terminal block on the left side of the internal control board. A label 'Ethernet cable' with a pointer line indicates the connection point. The cabinet contains various components including a fan, capacitors, and other electronic parts. The reference code '9316.emf' is located at the bottom right of the diagram.</p>
----------	--

4

Protection class IP21: Cut free the opening on the AC drive cover for the Ethernet cable.

Protection class IP54: Cut the rubber grommets open to slide the cables through. Should the grommets fold in while inserting the cable, just draw the cable back a bit to straighten the grommets up. Do not cut the grommet openings wider than what is necessary for the cables you are using.

NOTE! To meet the requirements of the enclosure class IP54, the connection between the grommet and the cable must be tight. Therefore, lead the first bit of the cable out of the grommet **straight** before letting it bend. If this is not possible, the tightness of the connection must be ensured with insulation tape or a cable tie.

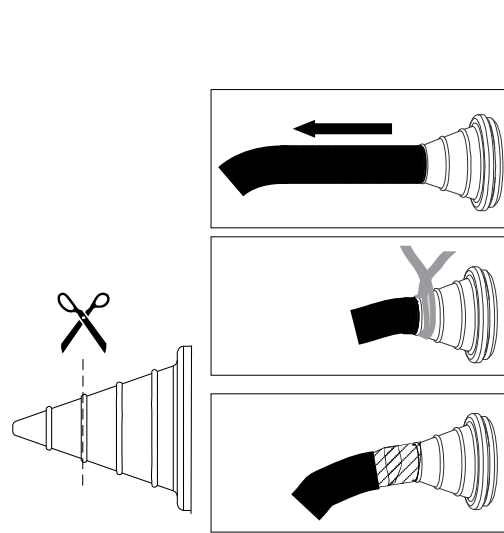
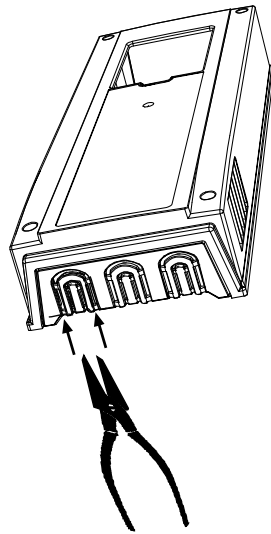

9068.emf

5

Remount the AC drive cover.

NOTE! When planning the cable runs, remember to keep the distance between the Ethernet cable and the motor cable at a **minimum of 30 cm**. See figure below.

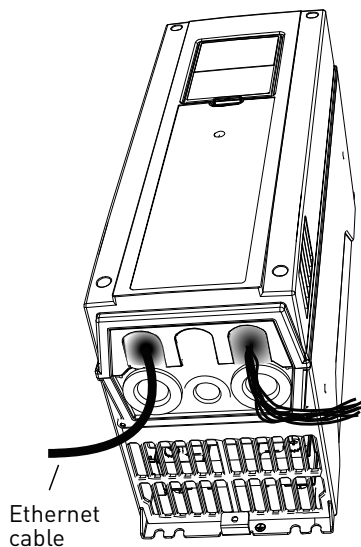

IP21

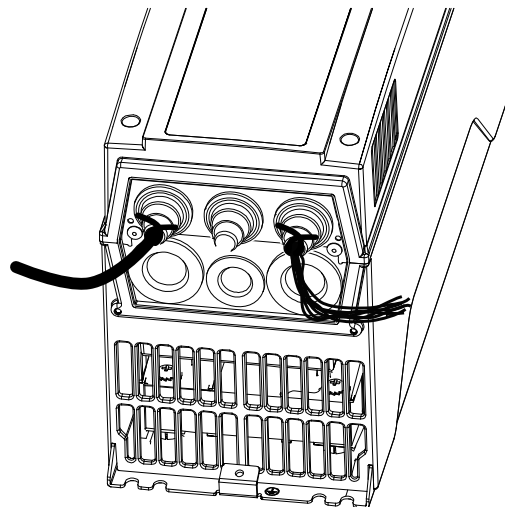

IP54

9265.emf

4.1.2 PREPARE FOR USE THROUGH RS485

1

Strip about 15 mm of the RS485 cable (see specification in Chapter 3.1) and cut off the grey cable shield. Remember to do this for both bus cables (except for the last device).
 Leave no more than 10 mm of the cable outside the terminal block and strip the cables at about 5 mm to fit in the terminals. See picture below.

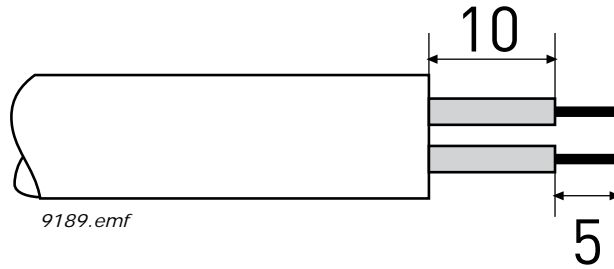

Also strip the cable now at such a distance from the terminal that you can fix it to the frame with the grounding clamp. Strip the cable at a maximum length of 15 mm. **Do not strip the aluminum cable shield!**

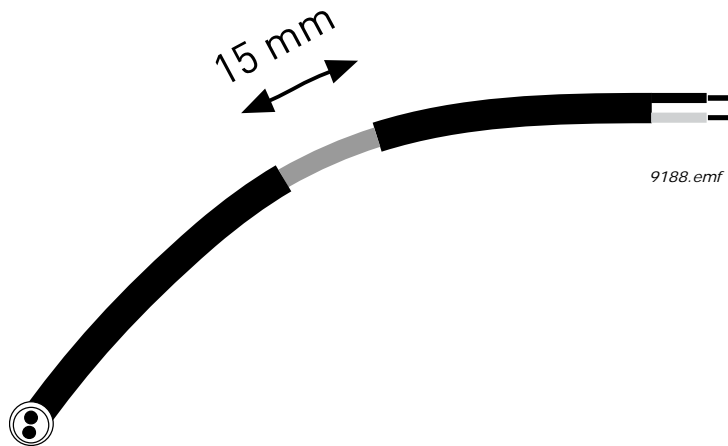

2

Then connect the cable to its appropriate terminals on Vacon 100 drive standard terminal block, terminals **A and B** (A = negative, B = positive). See figure below.

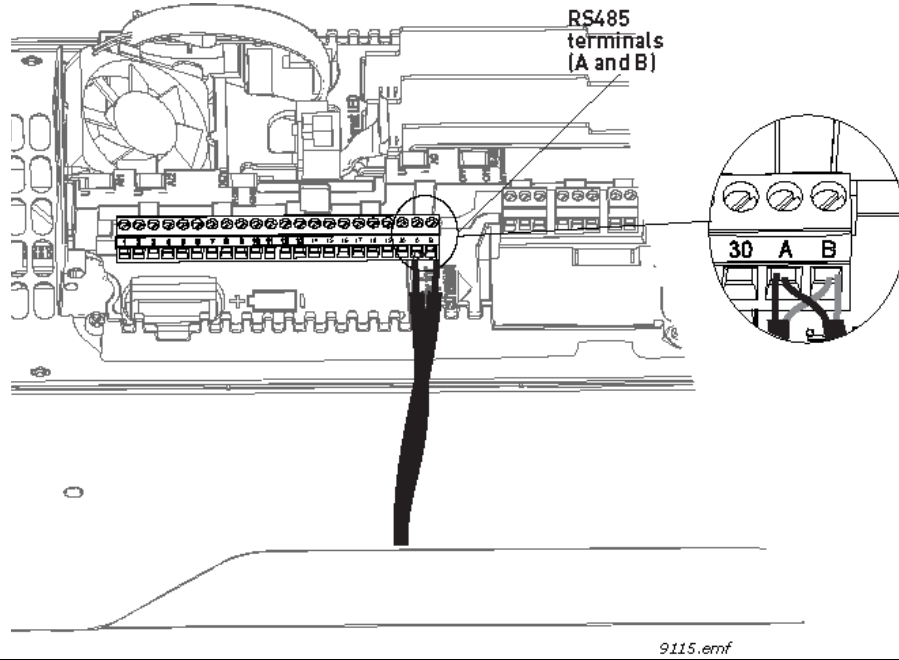

3

Using the cable clamp included in the delivery of the drive, ground the shield of the RS485 cable to the frame of the AC drive.

NOTE! This can be done in all drives if there is no difference in PE potential between the drives. However, if there is PE potential difference then the shield should be connected to PE only at one point in the system. The shields of the cables shall be joint but not connected to several PE points with different potential.

NOTE! This is only a principle drawing and the actual drive may look different.

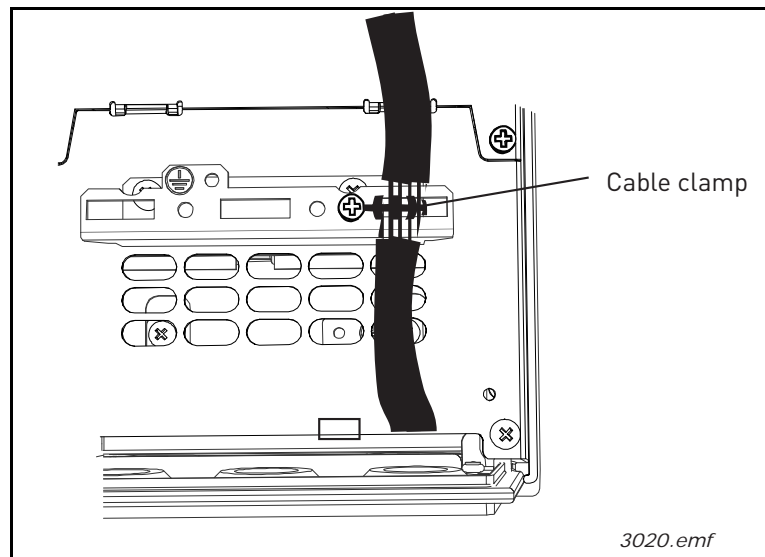

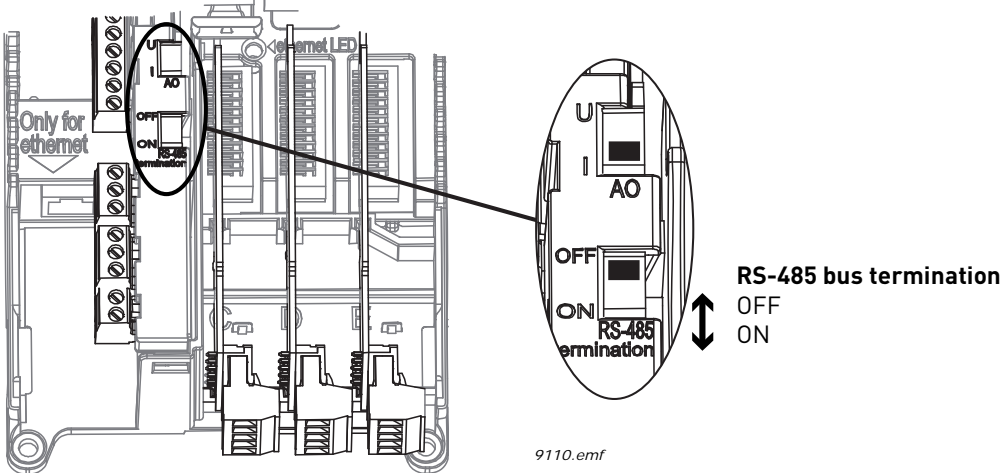
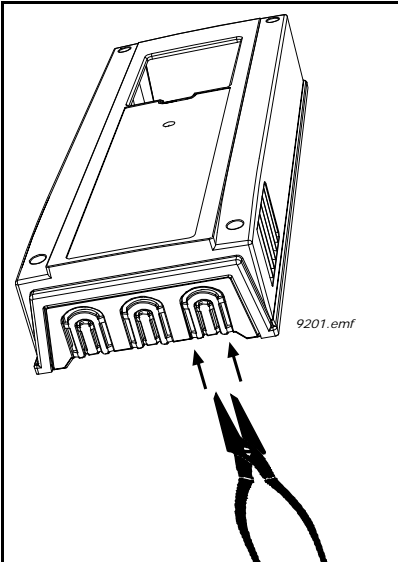
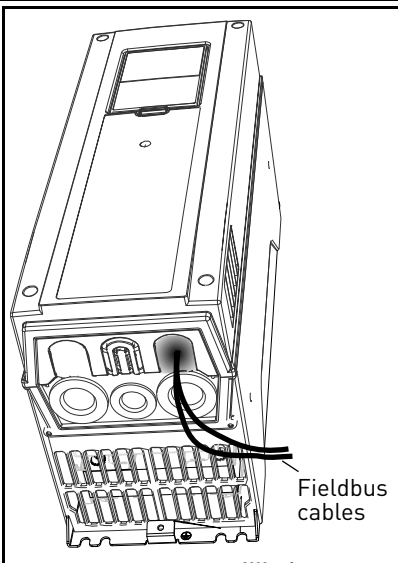
<p style="text-align: center; font-size: 2em; font-weight: bold;">4</p>	<p>If Vacon 100 is the last device on the bus, the bus termination must be set. Locate the DIP switches to the right of the control keypad of the drive and turn the switch for the RS485 bus termination resistor to position ON. Biasing is built in the termination resistor. See also step 6 on page 14.</p>  <p style="text-align: right; font-weight: bold;">RS-485 bus termination</p> <p style="text-align: right;">OFF ON</p> <p style="text-align: right; font-size: 0.8em;">9110.emf</p>
<p style="text-align: center; font-size: 2em; font-weight: bold;">5</p>	<p>Unless already done for the other control cables, cut free the opening on the AC drive cover for the RS485 cable (protection class IP21).</p> <p>NOTE! This is only a principle drawing and the actual drive may look different.</p>  <p style="text-align: right; font-size: 0.8em;">9201.emf</p>
<p style="text-align: center; font-size: 2em; font-weight: bold;">6</p>	<p>Remount the AC drive cover and run the RS485 cables as shown in picture.</p> <p>NOTE! When planning the cable runs, remember to keep the distance between the fieldbus cable and the motor cable at a minimum of 30 cm.</p>  <p style="text-align: right; font-size: 0.8em;">9202.emf</p>

7

The bus termination must be set for the first and the last device of the fieldbus line. See picture below. See also step 3 on page 13. We recommend that the first device on the bus and, thus, terminated was the Master device.

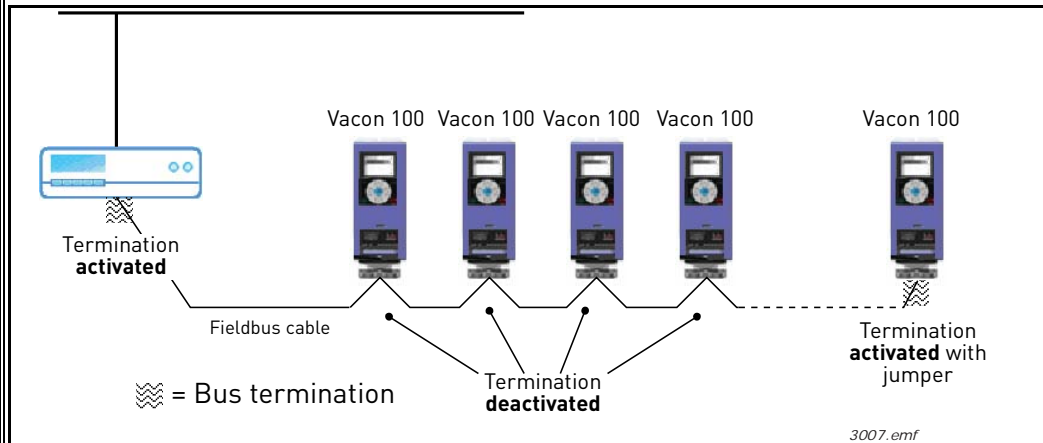

4.2 INSTALLATION IN VACON® 100 X

The AC drive can be connected to fieldbus either through RS485 or Ethernet. The connection for RS485 is on the standard I/O terminals (A and B) and the connection for Ethernet is left to the control terminals.

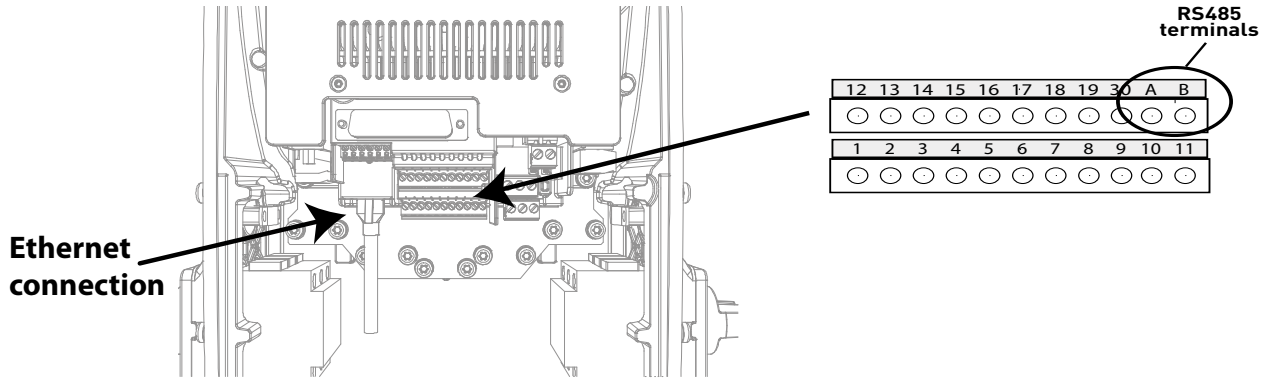

Figure 3.

4.2.1 PREPARE FOR USE THROUGH ETHERNET

1	Connect the Ethernet cable (see specification in Chapter 3.2) to its terminal and run the cable through the conduit plate.
----------	--

2	Remount the powerhead. NOTE: When planning the cable runs, remember to keep the distance between the Ethernet cable and the motor cable at a minimum of 30 cm.
----------	--

For more detailed information, see the user’s manual of the fieldbus you are using.

4.2.2 PREPARE FOR USE THROUGH RS485

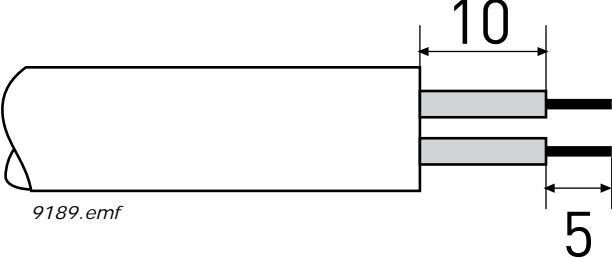
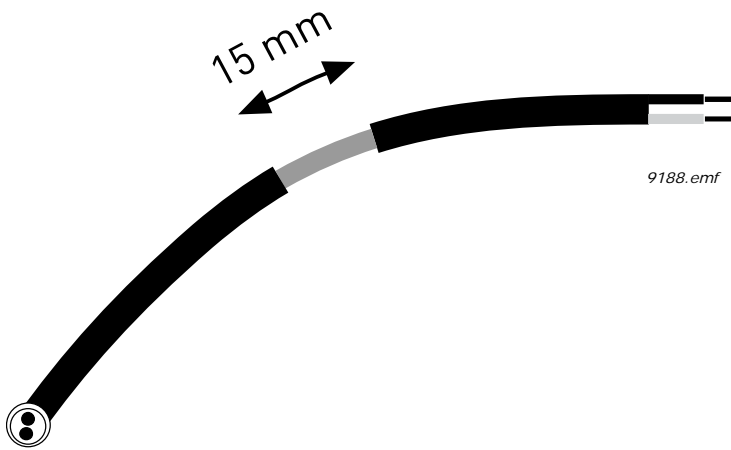
1	<p>Strip about 15 mm of the RS485 cable (see specification in Chapter 3.1) and cut off the grey cable shield. Remember to do this for both bus cables (except for the last device).</p> <p>Leave no more than 10 mm of the cable outside the terminal block and strip the cables at about 5 mm to fit in the terminals. See picture below.</p> <div style="text-align: center;">  <p>9189.emf</p> </div> <p>Also strip the cable now at such a distance from the terminal that you can fix it to the frame with the grounding clamp. Strip the cable at a maximum length of 15 mm. Do not strip the aluminum cable shield!</p> <div style="text-align: center;">  <p>9188.emf</p> </div>
---	--

2	<p>Then connect the cable to its appropriate terminals on VACON® 100 X AC drive standard terminal block, terminals A and B (A = negative, B = positive). See Figure 3.</p>
---	--

3	<p>Using the cable clamp included in the delivery of the drive, ground the shield of the RS485 cable to the frame of the AC drive.</p>
---	--

4

If VACON® 100 X AC drive is the last device on the bus, the bus termination must be set. Locate the DIP switches to the top of the control unit (see figure below).

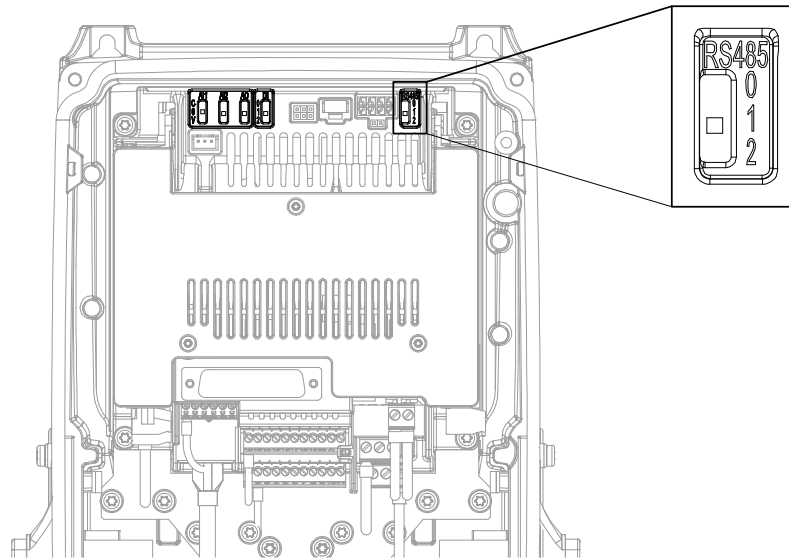

Turn the right most switch to position "1". Biasing is built in the termination resistor. See also step 6.

NOTE: When planning the cable runs, remember to keep the distance between the fieldbus cable and the motor cable at a **minimum of 30 cm**.

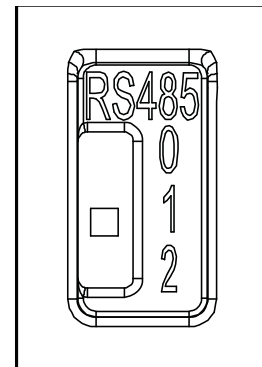

5

The bus termination must be set for the first and the last device of the fieldbus line. See picture below and step 4. We recommend that the first device on the bus and, thus, terminated, was the Master device.

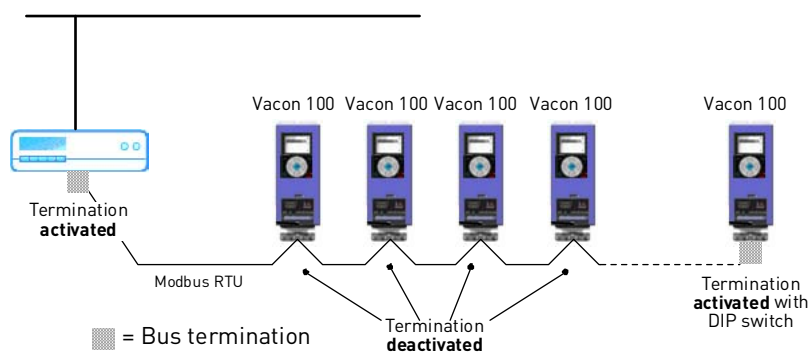

5. PROGRAMMING

For basic information on how to use the control keypad, see the corresponding drive Application Manual.

The navigation path to the fieldbus parameters may differ from application to application. The exemplary paths below apply to the Vacon[®] 100 drive.

Navigate: Main Menu > I/O and Hardware > RS-485 OR Ethernet > Common settings > Protocol (P5.x.1.1) > Edit > (Choose protocol)

1. First ensure that the right fieldbus protocol is selected.

Navigate: Main Menu > Quick Setup > Rem. Ctrl. Place (P1.15)

OR

Navigate: Main Menu > Parameters > Start/Stop Setup > Rem. Ctrl. Place

2. Select 'Fieldbus control' as the Remote Control Place.
3. Choose source of reference.

Navigate: Main Menu > Parameters > References

4. Set fieldbus parameters. See below.

5.1 MODBUS RS-485 PARAMETERS AND MONITORING VALUES

Table 4. Parameters related with Modbus used through RTU

Code	Parameter	Min	Max	Unit	Default	ID	Description
PARAMETERS							
P5.X.3.1.1	Slave address	1	247		1	2320	Unique slave device address.
P5.X.3.1.2	Baud rate	300	230400	bd	6	2378	Communication speed 300 600 1200 2400 4800 9600 19200 38400 57600 76800 115200 230400
P5.X.3.1.3	Parity type	0	2		0	2379	0 = Even 1 = Odd 2 = None
P5.X.3.1.4	Stopbits	1	3		3	2380	1 = 1 stop bit 2 = 1.5 stop bits 3 = 2 stop bits
P5.X.3.1.5	Communication time-out	0	65535	s	10	2321	0 = Not used
P5.X.3.1.6 ⁽¹⁾	Operate Mode	0	1		0	2374	0 = Slave 1 = Master
P5.x.3.1.7.1-30	IDMap IDs	0	65535		0		IDMap IDs
MONITORING VALUES							
P5.X.3.2.1	Fieldbus protocol status	1	3		1	2381	0 = Init 1 = Stopped 2 = Operational 3 = Faulted
P5.X.3.2.2	Communication status	0.0	99.999		0.0	2382	0-99 Number of messages with errors 0-999 Number of messages without communication errors
P5.X.3.2.3	Illegal functions	0				2383	See page 23.
P5.X.3.2.4	Illegal data addresses	0				2384	See page 23.
P5.X.3.2.5	Illegal data values	0				2385	See page 23.
P5.X.3.2.6	Slave device busy	0				2386	See page 23.
P5.X.3.2.7	Memory parity error	0				2387	See page 23.
P5.X.3.2.8	Slave device failure	0				2388	See page 23.
P5.X.3.2.9	Last fault response	0				2389	See page 23.
P5.X.3.2.10	Control word			hex		2390	See page 33 and page 36.
P5.X.3.2.11	Status word			hex		2391	See page 33 and page 36.

¹⁾ This feature is not supported in Vacon 100 HVAC. The default Vacon 100 application supports only Slave mode. A special application is required for Master functionality.

5.2 MODBUS TCP PARAMETERS AND MONITORING VALUES

5.2.1 ETHERNET COMMON SETTINGS

Table 5. Common settings for Modbus TCP (Ethernet)

Code	Parameter	Min	Max	Unit	Default	ID	Description
P5.X.1.1	IP address mode					2482	See page 25.
P5.X.1.2	IP address					2483	See page 25.
P5.X.1.3	Subnet mask					2484	See page 25.
P5.X.1.4	Default gateway					2485	See page 25.
P5.X.1.5	MAC address					2486	See page 25.

5.2.2 MODBUS TCP SETTINGS

Table 6. Parameters related to Modbus TCP

Code	Parameter	Min	Max	Unit	Default	ID	Description
PARAMETERS (Common settings)							
P5.X.2.1.1	Connection limit	0	3		2	2446	Number of allowed connections
P5.X.2.1.2	Unit identifier number	0	255		1	2447	See chapter 5.4.2 Modbus TCP settings
P5.X.2.1.3	Communication time-out	0	65535	s	0	2448	0 = Not used
P5.9.2.1.4.1-30	IDMap IDs	0	65535		0		IDMap IDs
MONITORING VALUES (Connection 1, Monitoring *)							
P5.X.2.2.1.1	Fieldbus protocol status	1	3			2449	1 = Stopped 2 = Operational 3 = Faulted
P5.X.2.2.1.2	Communication status	0.0	99.999		0.0	2450	0-99 Number of messages with errors 0-999 Number of messages without communication errors
P5.X.2.2.1.3	Illegal functions	0				2451	See page 26.
P5.X.2.2.1.4	Illegal data addresses	0				2452	See page 26.
P5.X.2.2.1.5	Illegal data values	0				2453	See page 26.
P5.X.2.2.1.6	Slave device busy	0				2454	See page 26.
P5.X.2.2.1.7	Memory parity error	0				2455	See page 26.
P5.X.2.2.1.8	Slave device failure	0				2456	See page 27.
P5.X.2.2.1.9	Last fault response	0				2457	See page 27.
P5.X.2.2.1.10	Control word			hex		2458	See page 33.
P5.X.2.2.1.11	Status word			hex		2459	See page 36.
MONITORING VALUES (Connection 2, Monitoring)*							

Code	Parameter	Min	Max	Unit	Default	ID	Description
P5.X.2.2.1.1	Fieldbus protocol status	1	3			2460	1 = Stopped 2 = Operational 3 = Faulted
P5.X.2.2.1.2	Communication status	0.0	99.999		0.0	2461	0-99 Number of messages with errors 0-999 Number of messages without communication errors
P5.X.2.2.1.3	Illegal functions	0				2462	See page 26.
P5.X.2.2.1.4	Illegal data addresses	0				2463	See page 26.
P5.X.2.2.1.5	Illegal data values	0				2464	See page 26.
P5.X.2.2.1.6	Slave device busy	0				2465	See page 26.
P5.X.2.2.1.7	Memory parity error	0				2466	See page 26.
P5.X.2.2.1.8	Slave device failure	0				2467	See page 27.
P5.X.2.2.1.9	Last fault response	0				2468	See page 27.
P5.X.2.2.1.10	Control word			hex		2469	See page 33.
P5.X.2.2.1.11	Status word			hex		2470	See page 36.
MONITORING VALUES (Connection 3, Monitoring)*							
P5.X.2.2.1.1	Fieldbus protocol status	1	3			2471	1 = Stopped 2 = Operational 3 = Faulted
P5.X.2.2.1.2	Communication status	0.0	99.999		0.0	2472	0-99 Number of messages with errors 0-999 Number of messages without communication errors
P5.X.2.2.1.3	Illegal functions	0				2473	See page 26.
P5.X.2.2.1.4	Illegal data addresses	0				2474	See page 26.
P5.X.2.2.1.5	Illegal data values	0				2475	See page 26.
P5.X.2.2.1.6	Slave device busy	0				2476	See page 26.
P5.X.2.2.1.7	Memory parity error	0				2477	See page 26.
P5.X.2.2.1.8	Slave device failure	0				2478	See page 27.
P5.X.2.2.1.9	Last fault response	0				2479	See page 27.
P5.X.2.2.1.10	Control word			hex		2480	See page 33.
P5.X.2.2.1.11	Status word			hex		2481	See page 36.

* Will appear only after connection has been established

5.3 MODBUS RTU PARAMETER DESCRIPTIONS

5.3.1 MODBUS RTU PARAMETERS

P5.X.3.1.1 SLAVE ADDRESS

Each slave must have a unique address (from 1 to 247) so that it can be addressed independently from other nodes.

P5.X.3.1.2 BAUD RATE

Select the communication speed for the network. The default value is 9600 baud.

P5.X.3.1.3 PARITY TYPE

Users can select the parity type for the network.

Modbus RTU specifies the stop bit configuration shown in table 7. The user can modify this stop bit configuration manually using parameter P5.X.3.1.4.

Table 7. Parity type

Table 8.

Parity type	Stopbits
Even	1
Odd	1
None	2

P5.X.3.1.4 STOP BITS

User can select the stop bit amount for the Modbus RTU network.

P5.X.3.1.5 COMMUNICATION TIME-OUT

Modbus initiates a communication error for a time defined with this parameter. '0' means that no fault is generated.

P5.X.3.1.6 OPERATE MODE

Used to select the operate mode of the Modbus RTU protocol (slave / master). This feature is not supported in Vacon 100 HVAC. The default Vacon 100 application supports only Slave mode. A special application is required for Master functionality.

- 0 = Slave
- 1 = Master

P5.8.3.1.7.1-30 IDMAP IDS

See Chapter 6.3.3.4.

5.3.2 MODBUS RTU MONITORING VALUES

P5.X.3.2.1 FIELDBUS PROTOCOL STATUS

Fieldbus Protocol Status tells the status of the protocol.

Table 9. FB protocol statuses

INITIALIZING	Protocol is starting up
STOPPED	Protocol is timeouted or not used
OPERATIONAL	Protocol is running
FAULTED	Major fault in protocol, requires restarting. If fault remains contact fieldbus@vacon.com

P5.X.3.2.2 COMMUNICATION STATUS

The *Communication status* shows how many error and how many good messages the AC drive has received. The Communication status includes a common error counter that counts CRC and parity errors and a counter for good messages.

Only messages to the current slave in use are counted in the good messages.

Table 10.

Good messages	
0...999	Number of messages received without errors
Bad Frames	
0...99	Number of messages received with errors

P5.X.3.2.3 ILLEGAL FUNCTIONS

This value counts error situations. The function code received in the query refers to an unallowed action for the server (or slave). This corresponds to Modbus fault code 01_h.

P5.X.3.2.4 ILLEGAL DATA ADDRESSES

This value counts error situations. The data address received in the query refers to an unallowed address for the server (or slave). This corresponds to Modbus fault code 02_h.

P5.X.3.2.5 ILLEGAL DATA VALUES

This value counts error situations. A value contained in the query data field refers to an unallowed value for server (or slave). This corresponds to Modbus fault code 03_h.

P5.X.3.2.6 SLAVE DEVICE BUSY

This value counts error situations. The server (or slave) is engaged in processing a long-duration program command. The client (or master) should retransmit the message later when the server (or slave) is free. This corresponds to Modbus fault code 06_h.

P5.X.3.2.7 MEMORY PARITY ERROR

This value counts error situations. The server (or slave) attempted to read record file but detected a parity error in the memory. This corresponds to Modbus fault code 08_h.

P5.X.3.2.8 SLAVE DEVICE FAILURE

This value counts error situations. An unrecoverable error occurred while the server (or slave) was attempting to perform the requested action. This corresponds to Modbus fault code 04_h.

P5.X.3.2.9 LAST FAULT RESPONSE

Shows the last fault response as *Fault code*.

P5.X.3.2.10 CONTROL WORD

Shows the *Control Word* received from the bus.

P5.X.3.2.11 STATUS WORD

Shows the current *Status Word* that is sent to the bus.

5.4 MODBUS TCP PARAMETER DESCRIPTIONS

5.4.1 ETHERNET COMMON SETTINGS

P5.X.1.1 IP ADDRESS MODE

Selectable alternatives are *DHCP* (Dynamic Host Configuration Protocol) and *Fixed*.

DHCP protocol gives IP addresses to new devices connecting to local network. This address is valid for a certain period of time. If no DHCP server is found an automatic random IP is given.

A fixed IP address is specified manually and it does not change.

When the mode is changed from DHCP to Fixed the addresses will read

IP: 192.168.0.10

Subnet mask: 255.255.0.0

Default gateway: 192.168.0.1

P5.X.1.2 IP ADDRESS

An *IP address* is a series of numbers (like above) specific to the device connected to the Internet.

P5.X.1.3 SUBNET MASK

The network mask marks all the bits of an IP address for the identification of the network and the subnetwork.

P5.X.1.4 DEFAULT GATEWAY

Gateway address is the IP address of a network point that acts as an entrance to another network.

P5.X.1.5 MAC ADDRESS

The MAC address of the control board.

MAC address (Media Access Control) is a unique address given to each network host. It is not editable.

5.4.2 MODBUS TCP SETTINGS

5.4.2.1 Common settings

P5.X.2.1.1 CONNECTION LIMIT

Defines how many clients can access the server simultaneously.

P5.X.2.1.2 UNIT IDENTIFIER

The Modbus 'slave address' field usually used on Modbus Serial Line is replaced by a single byte 'Unit Identifier'.

On TCP/IP, the Modbus server is addressed using its IP address; therefore, the Modbus Unit Identifier is useless.

P5.X.2.1.3 COMMUNICATION TIME-OUT

Modbus initiates a communication error if the Ethernet connection is lost. Communication time-out parameters define the minimum delay between packages received from the client. The timer is reset and started after each received package. This parameter can be used if the client is periodically polling the slaves.

P5.9.2.1.4.1-30 IDMAP IDS

See Chapter 6.3.3.4.

5.4.3 MODBUS TCP MONITORING VALUES

These values will not appear before the connection is established.

5.4.3.1 Connection 1

P5.X.2.2.1.1 *FIELD BUS PROTOCOL STATUS*

Fieldbus Protocol Status tells the status of the protocol.

Table 11. FB protocol statuses

INITIALIZING	Protocol is starting up
STOPPED	Protocol is timeouted or not used
OPERATIONAL	Protocol is running
FAULTED	Major fault in protocol, requires restarting. If fault remains contact fieldbus@vacon.com

P5.X.2.2.1.2 *COMMUNICATION STATUS*

The *Communication status* shows how many error and how many good messages the AC drive has received. The Communication status includes a common error counter that counts errors and a counter for good messages.

Table 12. Communication status

Good messages	
0...999	Number of messages received without errors
Bad Frames	
0...99	Number of messages received with errors

P5.X.2.2.1.3 *ILLEGAL FUNCTIONS*

This value counts error situations. The function code received in the query refers to an unallowed action for the server (or slave). This corresponds to Modbus fault code 01_h.

P5.X.2.2.1.4 *ILLEGAL DATA ADDRESSES*

This value counts error situations. The data address received in the query refers to an unallowed address for the server (or slave). This corresponds to Modbus fault code 02_h.

P5.X.2.2.1.5 *ILLEGAL DATA VALUES*

This value counts error situations. A value contained in the query data field refers to an unallowed value for server (or slave). This corresponds to Modbus fault code 03_h.

P5.X.2.2.1.6 *SLAVE DEVICE BUSY*

This value counts error situations. The server (or slave) is engaged in processing a long-duration program command. The client (or master) should retransmit the message later when the server (or slave) is free. This corresponds to Modbus fault code 06_h.

P5.X.2.2.1.7 *MEMORY PARITY ERROR*

This value counts error situations. The server (or slave) attempted to read record file but detected a parity error in the memory. This corresponds to Modbus fault code 08_h.

P5.X.2.2.1.8 SLAVE DEVICE FAILURE

This value counts error situations. An unrecoverable error occurred while the server (or slave) was attempting to perform the requested action. This corresponds to Modbus fault code 04_h.

P5.X.2.2.1.9 LAST FAULT RESPONSE

Shows the last fault response as *Fault code*.

P5.X.2.2.1.10 CONTROL WORD

Shows the Control Word received from the bus.

P5.X.2.2.1.11 STATUS WORD

Shows the current Status Word that is sent to the bus.

5.4.3.2 Connection 2

The monitoring values display the same pieces of information as for Connection 1 (Chapter 5.2.2), for the 2nd and 3rd connections".

5.4.3.3 Connection 3

The monitoring values display the same pieces of information as for Connection 1 (Chapter 5.2.2), for the 2nd and 3rd connections".

6. COMMUNICATIONS

Features of the Modbus-Vacon interface:

- Direct control of Vacon drive (e.g. Run, Stop, Direction, Speed reference, Fault reset)
- Full access to all Vacon parameters
- Monitor Vacon status (e.g. Output frequency, Output current, Fault code)

6.1 DATA ADDRESSES IN MODBUS MESSAGES

All data addresses in Modbus messages are referenced to zero. The first occurrence of a data item is addressed as item number zero. For example:

- The coil known as 'Coil 1' in a programmable controller is addressed as 'Coil 0000' in the data address field of a Modbus message.
- Coil 127 decimal is addressed as 'Coil 007E hex' (126 decimal).
- Holding register 40001 is addressed as register 0000 in the data address field of the message. The function code field already specifies a 'holding register' operation. Therefore the '4XXXX' reference is implicit.
- Holding register 40108 is addressed as register 006B hex (107 decimal).

6.2 SUPPORTED MODBUS FUNCTIONS

The Vacon variables and fault codes as well as the parameters can be read and written from Modbus. The parameter addresses are determined in the application. Every parameter and actual value have been given an ID number in the application. The ID numbering of the parameter as well as the parameter ranges and steps can be found in the application manual in question. The parameter value must be given without decimals. If several parameters/actual values are read with one message, the addresses of the parameters/actual values must be consecutive.

Table 13. Supported functions

Function (dec)	Function (hex)	Modbus Function Name	TCP/RTU	Access type	Address range (hex)
1	1	Read coils	TCP only	Discrete (1-bit)	00000-0FFFF
2	2	Read Discrete Inputs	TCP only	Discrete (1-bit)	10000-1FFFF
3	3	Read Holding Registers	TCP&RTU	Register (16bit)	40000-4FFFF
4	4	Read Input Registers	TCP&RTU	Register (16bit)	30000-3FFFF
5	5	Write Single Coils	TCP only	Discrete (1-bit)	00000-0FFFF
6	6	Write Single Register	TCP&RTU	Register (16bit)	40000-4FFFF

Function (dec)	Function (hex)	Modbus Function Name	TCP/RTU	Access type	Address range (hex)
15	F	Write Multiple Coils	TCP only	Discrete (1-bit)	00000-0FFFF
16	10	Write Multiple Registers	TCP&RTU	Register (16bit)	40000-4FFFF
23	17	Read/Write Multiple Registers	TCP&RTU	Register (16bit)	40000-4FFFF
<p>NOTE! Broadcasting not supported in TCP. Broadcast supported with function code 06 and 16 in RTU</p>					

The address ranges of the different function codes are in many cases not relevant to the user and can be ignored. The targeted information type (coil, register etc.) can be selected separate from the address.

6.3 MODBUS DATA MAPPING

6.3.1 COILS REGISTERS

A "coil" in Modbus is a single-bit binary data item which can be both read and written. In Vacon[®] 100 the coils refer to some bits in the fieldbus control word." See page 33.

Table 14. Defined coil registers

Address	Function	Purpose
0001	RUN/STOP	Control Word, bit 0
0002	Direction	Control Word, bit 1
0003	Fault reset	Control Word, bit 2

6.3.2 DISCRETE INPUTS

A "discrete input" in Modbus is a single-bit binary data item which is read-only. In Vacon 100 the discrete inputs refer to the fieldbus status word bits. See page 36.

Table 15. Defined Input Discrete

Address	Function	Purpose
10001	Ready	Status Word, bit 0
10002	Run	Status Word, bit 1
10003	Direction	Status Word, bit 2
10004	Fault	Status Word, bit 3
10005	Alarm	Status Word, bit 4
10006	At reference	Status Word, bit 5
10007	Zero speed	Status Word, bit 6
10008	Flux ready	Status Word, bit 7

6.3.3 HOLDING REGISTERS AND INPUT REGISTERS

An "input register" in Modbus is a 16-bit value which is read-only. A "holding register" in Modbus is a 16-bit value which can be both read and written. Holding and input registers are accessed using different function codes, and the address ranges are different. In Vacon 100 the same information can be accessed as input registers and holding registers, i.e. input register X refers to the same 16-bit value as the holding register X.

The Modbus registers are mapped to the Vacon 100 drive as follows

Table 16. Vacon 100 input and holding registers

Register number	Purpose	Access type	See
0001 - 2000	Vacon Application ID's	16bit	Table 16
2001 - 2050	FBProcessDataIN	16bit	Table 19
2051 - 2099	FBProcessDataIN	32bit	Table 19
2101 - 2150	FBProcessDataOUT	16bit	Table 19
2151 - 2199	FBProcessDataOUT	32bit	Table 19
2200 - 10000	Vacon Application ID's	16bit	Table 16
10501 - 10530	IDMap	16bit	Table 29
10601 - 10630	IDMap Read/Write	16bit	Table 30
10701 - 10760	IDMap Read/Write	32bit	Table 30
20001 - 40000	Vacon Application ID's	32bit	Table 16
40001 - 40007	Operation day counter	16bit	Table 32
40101 - 40107	Resettable operation day counter	16bit	Table 33
40201 - 40203	Energy counter	16bit	Table 34
40301 - 40303	Resettable energy counter	16bit	Table 35
40401 - 40430	Fault history	16bit	Table 36

Table 17. Maximum lengths of Modbus Read and Write requests

Address range	Type	R/W #
0001-2000	Vacon application id's	30/30
2001-2011	FBProcessDataIN	11/11
2101-2111	FBProcessDataOUT	11/0 Read only
10501-10530	IDMap table parameter IDs	30/30
10601-10630	IDMap table parameter values	30/30
40401-40430	Fault history	30/30 Read only

Accessing unsupported values returns the error code "Illegal Data Address".

6.3.3.1 Vacon Application ID's

Application ID's are parameters that depend on the AC drive's application. These parameters can be read and written by pointing the corresponding memory range directly or by using the so-called

ID map (Chapter 6.3.3.4). It is easiest to use a straight address if you want to read a single parameter value or parameters with consecutive ID numbers. It is possible to read 12 consecutive ID addresses.

Table 18. Application ID's

Register number	Purpose	Application ID
0001-2000	Application parameters	1-2000
2200-10000	Application parameters	2200-10000

6.3.3.2 FB Process data IN

The process data fields are used to control the drive (e.g. Run, Stop , Reference, Fault Reset) and to quickly read actual values (e.g. Output frequency, Output current, Fault code). The fields are structured as follows:

Process Data Master -> Slave (max 22 bytes)

Table 19. Fieldbus Process Data IN

Address		Name	Range/Type
16-bit*	32-bit		
2001	2051 = High data 2052 = Low data	FB Control Word	Binary coded
2002	-	Reserved	Binary coded
2003	2053 = High data 2054 = Low data	FB Speed Reference	0...100.00 % unit 0.01%
2004	2055 = High data 2056 = Low data	FB Process Data In 1	See Chapter 9.
2005	2057 = High data 2058 = Low data	FB Process Data In 2	See Chapter 9.
2006	2059 = High data 2060 = Low data	FB Process Data In 3	See Chapter 9.
2007	2061 = High data 2062 = Low data	FB Process Data In 4	See Chapter 9.
2008	2063 = High data 2064 = Low data	FB Process Data In 5	See Chapter 9.
2009	2065 = High data 2066 = Low data	FB Process Data In 6	See Chapter 9.
2010	2067 = High data 2068 = Low data	FB Process Data In 7	See Chapter 9.
2011	2069 = High data 2070 = Low data	FB Process Data In 8	See Chapter 9.

*. In Vacon 100, the Control Word and the Status Word are formed of 32 bits. Only the initial 16 bits can be read in the 16-bit area.

Control word bits

The Control word is composed of 32 bits. Meanings of bits are described below. Unused bits have to be set to zero.

Table 20. Control Word bits

Table 21:

Bit	Name	Value = 1	Value = 0	Vacon 100 HVAC	Vacon 100
B0	Start/Stop	Start request	Stop request	Supported	Supported
B1	Direction	Reverse	Forward	Supported	Supported
B2	Fault reset	Reset faults	No action	Supported	Supported
B3	Coast Stop Mode	Stop mode is coasting	Normal stop mode	Supported	Supported
B4	Ramp Stop Mode	Stop mode is ramping	Normal stop mode	Supported	Supported
B5	Short Ramp Time	Ramp stop time is shortened	Normal ramp stop time		Supported
B6	Freeze Fieldbus Ref	Drive does not accept new fieldbus reference	Drive follows changes in fieldbus reference	Supported	Supported
B7	Force Fieldbus Ref. to Zero	Fieldbus reference is forced to zero	No action		Supported
B8	Force Fieldbus Control	Fieldbus control place is forced	Normal control place	Supported	Supported
B9	Force Fieldbus Reference	Fieldbus reference is forced	Normal reference	Supported	Supported
B10	Jogging Reference 1	Activates jogging reference 1	No action		Supported
B11	Jogging Reference 2	Activates jogging reference 2	No action		Supported
B12	Quick Stop	Drive does quick stop	No action		Supported
B13-B31	Reserved	Not used			

6.3.3.3 FB Process data OUT**Process Data Slave -> Master (max 22 bytes)***Table 22. Fieldbus Process Data Out*

Address		Name	Range/Type
16-bit	32-bit		
2101	2151 = High data 2152 = Low data	FB Status Word	Binary coded
2102	-	Reserved	Binary coded
2103	2153 = High data 2154 = Low data	FB Actual Speed	0...100.00, unit 0.01%
2104	2155 = High data 2156 = Low data	FB Process Data Out 1	See Chapter 9.
2105	2157 = High data 2158 = Low data	FB Process Data Out 2	See Chapter 9.
2106	2159 = High data 2160 = Low data	FB Process Data Out 3	See Chapter 9.
2107	2161 = High data 2162 = Low data	FB Process Data Out 4	See Chapter 9.
2108	2163 = High data 2164 = Low data	FB Process Data Out 5	See Chapter 9.
2109	2165 = High data 2166 = Low data	FB Process Data Out 6	See Chapter 9.
2110	2167 = High data 2168 = Low data	FB Process Data Out 7	See Chapter 9.
2111	2169 = High data 2170 = Low data	FB Process Data Out 8	See Chapter 9.

Table 23.

Table 24.

Bit	Name	Value=1	Value=2	Vacon 100 HVAC	Vacon 100
Bit 0	Ready	Ready for operation	Not Ready	Supported	Supported
Bit 01	Run	Running	Stopped	Supported	Supported
Bit 2	Direction	Counterclockwise	Clockwise	Supported	Supported
Bit 3	Fault	A fault is active	No fault active	Supported	Supported
Bit 4	Alarm	An alarm is active	No alarm active	Supported	Supported
Bit 5	At Reference	Reference frequency is reached	Reference frequency is not reached	Supported	Supported
Bit 6	Zero Speed	Motor is at zero speed	Motor is at non-zero speed	Supported	Supported
Bit 7	Flux Ready	Motor is magnetized	Motor is not magnetized	Supported	Supported
Bit 8-28	Reserved	Not used		Supported	Supported

Status Word bits

The Status word is composed of 32 bits. The meanings of bits are described below.

Table 25. Status Word bits B1-B28

Table 26:

Bit	Name	Value = 1	Value = 0	Description
B0	Ready	Ready	Not ready	Indicates whether the drive is ready or not
B1	Run	Running	Stop	Indicates whether the drive is running or stopped
B2	Direction	Counterclockwise	Clockwise	Indicates the rotation direction of the motor
B3	Fault	Faulted	Not faulted	Indicates if a fault is active
B4	Alarm	Alarm	No alarm	Indicates if an alarm is active
B5	AtReference	True	False	Reference frequency reached
B6	ZeroSpeed	True	False	Motor running at zero speed
B7	FluxReady	True	False	Motor is magnetized
B8-B28	Not used			

Table 27. Status Word bits B29-B31, descriptions of bit connections

Table 28:

B29 Control place	B30 Control place	B31 Control place	Description
0	0	1	Fieldbus
0	1	0	Keypad
0	1	1	PC tool
1	0	0	I/O terminals

The use of process data depends on the application. In a typical situation, the device is started and stopped with the ControlWord (CW) written by the Master and the Rotating speed is set with Reference (REF). With PD1...PD8 the device can be given other reference values (e.g. Torque reference).

With the StatusWord (SW) read by the Master, the status of the device can be seen. Actual Value (ACT) and PD1...PD8 show the other actual values.

6.3.3.4 ID map

Using the ID map, you can read consecutive memory blocks that contain parameters whose ID's are not in a consecutive order. The address range 10501 - 10530 is called 'IDMap', and it includes an address map in which you can write your parameter ID's in any order. The address range 10601 to 10630 is called 'IDMap Read/Write,' and it includes values for parameters written in the IDMap. As soon as one ID number has been written in the map cell 10501, the corresponding parameter value can be read and written in the address 10601, and so on.

IDMap IDs can be also configured from the panel or VaconLive PC tool. IDmap menu is located under Modbus TCP and Modbus RTU settings. See details in chapters 5.1 and 5.2.2.

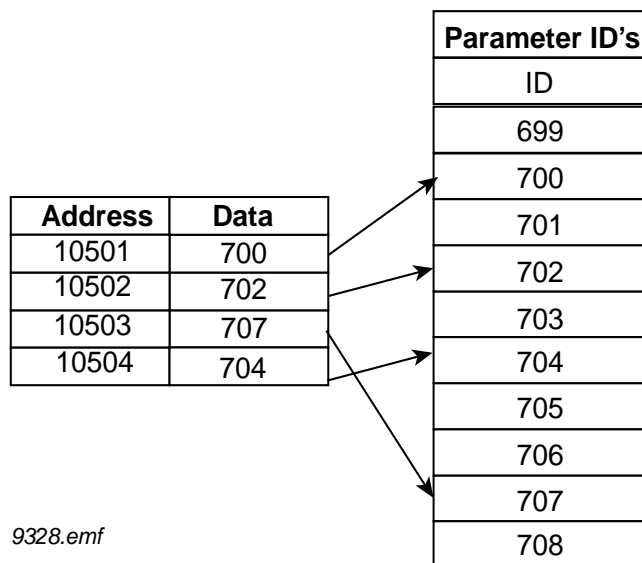

9328.emf

Table 29. IDMap initialization

Once the IDMap address range has been initialized with any parameter ID number, the parameter value can be read and written in the IDMap Read/Write address range address IDMap address + 100.

Table 30. Parameter Values in 16-bit IDMap Read/Write registers

Address	Data
10601	Data included in parameter ID700
10602	Data included in parameter ID702
10603	Data included in parameter ID707
10604	Data included in parameter ID704

If the IDMap table has not been initialized, all data fields are showing the value '0'. Once the IDMap table has been initialized, the parameter ID's are stored in the Vacon 100 flash memory.

Example of 32Bit IDMap

Table 31. Example of parameter values in 32-bit IDMap Read/Write registers

Address	Data
10701	Data High, parameter ID700
10702	Data Low, parameter ID700
10703	Data High, parameter ID702
10704	Data Low, parameter ID702

6.3.3.5 Operation day counter

Table 32. Operation day counter

Address	Purpose
40001	Years
40002	Days
40003	Hours
40004	Minutes
40005	Seconds

6.3.3.6 Resettable operation day counter

Reset the counter by writing "1" for parameter ID2311.

Table 33. Resettable operation day counter

Address	Purpose
40101	Years
40102	Days
40103	Hours
40104	Minutes
40105	Seconds

6.3.3.7 Energy counter

The last number of the *Format* field indicates the decimal point place in the *Energy* field. If the number is bigger than 0, move the decimal point to the left by the number indicated. For example, Energy = 1200, Format = 52. Unit = 1. Energy = 12.00kWh.

Table 34. Energy counter

Address	Purpose
40201	Energy
40202	Format
40203	Unit 1 = kWh 2 = MWh 3 = GWh 4 = TWh

6.3.3.8 Resettable energy counter

Reset the counter by writing "1" for parameter ID2312.

Table 35. Resettable energy counter

Address	Purpose
40301	Energy
40302	Format
40303	Unit 1 = kWh 2 = MWh 3 = GWh 4 = TWh

6.3.3.9 Fault history

The fault history can be viewed by reading from address 40401 onward. The faults are listed in chronological order so that the latest fault is mentioned first and the oldest last. The fault history can contain 29 faults at the same time. The fault history contents are represented as follows.

Table 36. Fault history

Address	Register	Purpose
40401	440401	
40402	440402	
40403	440403	
...	...	
40429	440429	

6.4 EXAMPLE MESSAGES

Example 1

In this example the speed reference of the drive is set to 50% and the drive is commanded to run. The Process Data IN registers 2001...2003 are written to achieve this. The data to the control word is 0001h (run request) and the data to the speed reference is 1388h (5000d). The Modbus function used to write the values is 16 (Write Multiple Registers).

Write the process data 42001...42003 with command 16 (Preset Multiple Registers).

Command Master - Slave:

Table 37.

ADDRESS	01 hex Slave address 1 hex (= 1)
FUNCTION	10 hex Function 10 hex (= 16)
DATA	Starting address HI 07 hex Starting address 07D0 hex (= 2000)
	Starting address LO D0 hex
	No. of registers HI 00 hex
	No. of registers LO 03 hex Number of registers 0003 hex (= 3)
	Byte count 06 hex Byte count 06 hex (= 6)
	Data HI 00 hex Data 1 = 0001 hex (= 1). Setting control word run bit to 1.
	Data LO 01 hex
	Data HI 00 hex Data 2 = 0000 hex (= 0).
	Data LO 00 hex
	Data HI 13 hex Data 3 = 1388 hex (= 5000), Speed Reference to 50.00%
	Data LO 88 hex
ERROR	CRC HI C8 hex CRC field C8CB hex (= 51403)
CHECK	CRC LO CB hex

Message frame:

Table 38.

01	10	07	D0	00	03	06	00	01	00	00	13	88	C8	CB
----	----	----	----	----	----	----	----	----	----	----	----	----	----	----

The reply to Preset Multiple Registers message is the echo of 6 first bytes.

Answer Slave - Master:

Table 39.

ADDRESS		01 hex Slave address 1 hex (= 1)
FUNCTION		10 hex Function 10 hex (= 16)
DATA	Starting address HI	07 hex Starting address 07D0 hex (= 2000)
	Starting address LO	D0 hex
	No. of registers HI	00 hex Number of registers 0003 hex (= 3)
	No. of registers LO	03 hex
ERROR	CRC HI	80 hex CRC 8085 hex (= 32901)
CHECK	CRC LO	85 hex

Reply frame:

Table 40.

01	10	07	D0	00	03	80	85
----	----	----	----	----	----	----	----

Example 2:

In this example the actual speed and the first Process Data OUT variable of the drive is read. The Process Data OUT registers 2103 and 2104 are read to achieve this. The Modbus function used to read the values is 4 (Read Input Registers).

Read the Process Data 42103...42104 with command 4 (Read Input Registers).

Command Master - Slave:

Table 41.

ADDRESS		01 hex Slave address 1 hex (= 1)
FUNCTION		04 hex Function 4 hex (= 4)
DATA	Starting address HI	08 hex
	Starting address LO	36 hex
	No. of registers HI	00 hex Number of registers 0002 hex (= 2)
	No. of registers LO	02 hex
ERROR	CRC HI	93 hex CRC field 93A5 hex (= 37797)
CHECK	CRC LO	A5 hex

Message frame:

Table 42.

01	04	08	36	00	02	93	A5
----	----	----	----	----	----	----	----

The reply to the Read Input Registers message contains the values of the read registers.

Answer Slave - Master:

Table 43.

ADDRESS		01 hex Slave address 1 hex (= 1)
FUNCTION		04 hex Function 4 hex (= 4)
DATA	Byte count	04 hex Byte count 4 hex (= 4)
	Data HI	13 hex Speed reference = 1388 hex (=5000 => 50.00%)
	Data LO	88 hex
	Data HI	09 hex Output Frequency = 09C4 hex (=2500 =>25.00Hz)
	Data LO	C4 hex
ERROR	CRC HI	78 hexCRC field 78E9 hex (=30953)
CHECK	CRC LO	E9 hex

Reply frame:

Table 44.

01	04	04	13	88	09	C4	78	E9
----	----	----	----	----	----	----	----	----

Example of an exception response

In an exception response, the Slave sets the *most-significant bit (MSB)* of the function code to 1. The Slave returns an exception code in the data field.

Command Master - Slave:

Table 45.

ADDRESS		01 hex Slave address 1 hex (= 1)
FUNCTION		04 hex Function 4 hex (= 4)
DATA	Starting address HI	17 hex Starting address 1770 hex (= 6000)
	Starting address LO	70 hex
	No. of registers HI	00 hex Invalid number of registers 0005 hex (= 5)
	No. of registers LO	05 hex

Table 45.

ERROR	CRC HI	34 hex
CHECK	CRC LO	66 hex CRC field 3466 hex (=13414)

Message frame:

Table 46.

01	04	17	70	00	05	34	66
----	----	----	----	----	----	----	----

Exception response:

Answer Slave - Master:

Table 47.

ADDRESS	01 hex Slave address 1 hex (= 1)
FUNCTION	84 hex Most significant bit set to 1
ERROR CODE	04 hex Error code 04 => Slave Device Failure
ERROR CRC HI	42 hex CRC field 42C3 hex (= 17091)
CHECK CRC LO	C3 hex

Reply frame:

Table 48.

01	84	04	42	C3
----	----	----	----	----

7. FAULT TRACING

When an unusual operating condition is detected by the AC drive control diagnostics, the drive initiates a notification visible, for example, on the keypad. The keypad will show the ordinal number of the fault, the fault code and a short fault description.

The fault can be reset with the Reset button on the control keypad or via the I/O terminal. The faults are stored in the Fault history menu which can be browsed. The different fault codes you will find in the table below. This fault table presents only the faults related to the fieldbus in use.

NOTE! When contacting distributor or factory because of a fault condition, always write down all texts and codes on the keypad display and send a description of the problem together with the *Drive Info File* to fieldbus@vacon.com.

7.1 TYPICAL FAULT CONDITIONS

Table 49. Typical fault conditions

Fault condition	Possible cause	Remedy
Termination resistor	Missing or excessive termination resistor.	Install termination resistors at both ends of the fieldbus line.
Cabling	<ul style="list-style-type: none"> Supply or motor cables are located too close to the fieldbus cable Wrong type of fieldbus cable Too long cabling 	
Grounding	Inadequate grounding.	Ensure grounding in all points on the net
Connections	Faulty connections. <ul style="list-style-type: none"> Excessive stripping of cables Conductors in wrong terminals Too loose connections of conductors 	
Parameter	<ul style="list-style-type: none"> Faulty address Overlapping slave addresses Wrong baud rate Wrong control place selected 	

7.2 RS-485 BUS BIASING

When none of the devices on the RS-485 bus is sending data, all devices are in idle status. This being the case, the bus voltage is in indefinite state, usually near 0 V due to the termination resistors. This may cause problems in character reception because the single characters in serial communication begin with start bit referring to bus status '0' with voltage of less than -200mV whereas the bus status '1' corresponds to bus voltage of more than +200mV. The RS-485 standard considers the voltage interval -200mV...+200mV as undefined state. Bus biasing is therefore needed to maintain the voltage in status '1' (above +200mV) also between the messages.

To bias the bus you will have to add a separate active termination resistor specifically designed for the RS-485 bus (e.g. Siemens active RS 485 terminating element (6ES7972-0DA00-0AA0)).

7.3 OTHER FAULT CONDITIONS

The following fault tracing diagram will help you to locate and fix some of the most usual problems. If the problem persists contact your local distributor.

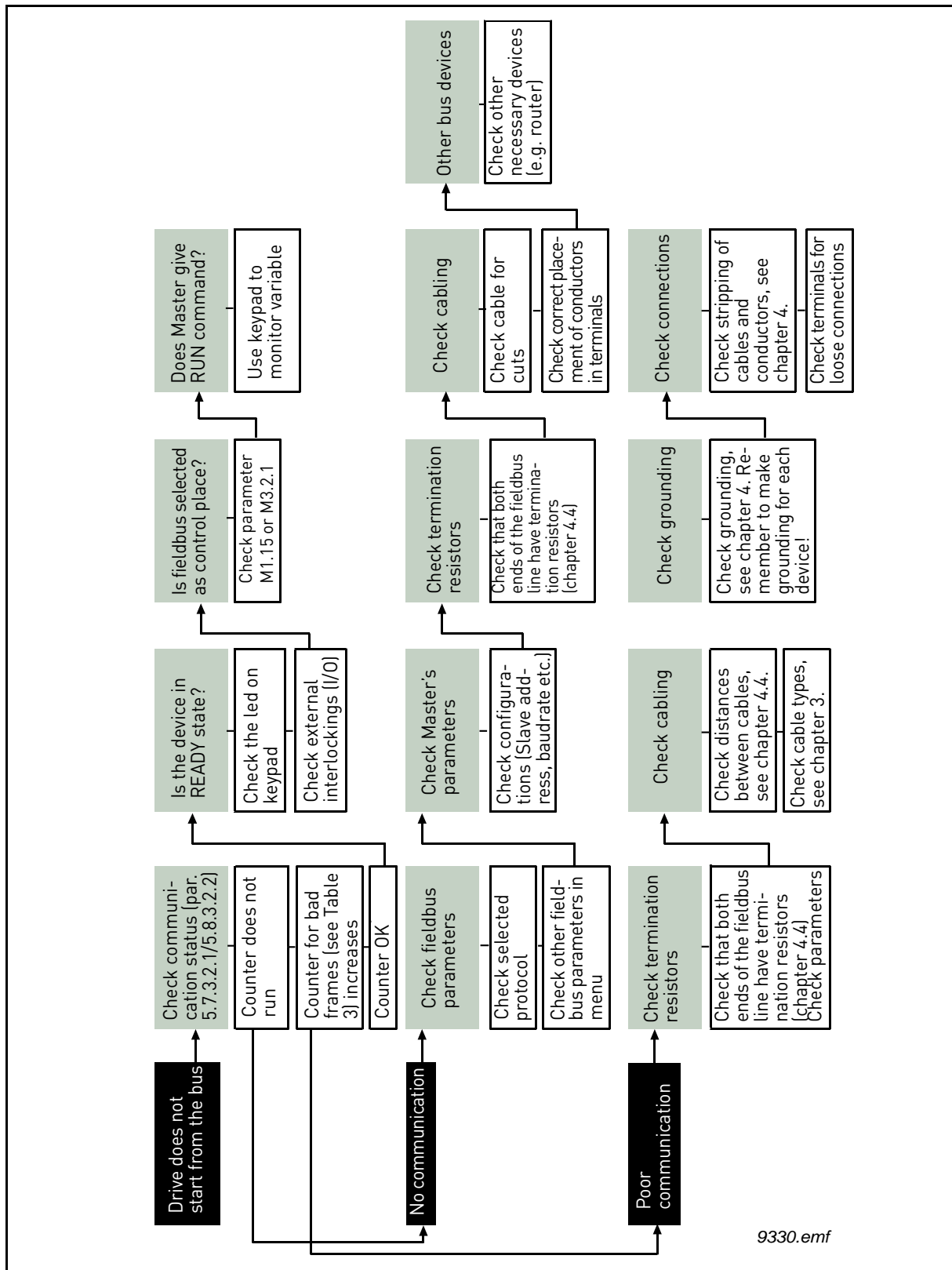

Figure 4. Fault tracing diagram for Modbus RTU

9330.emf

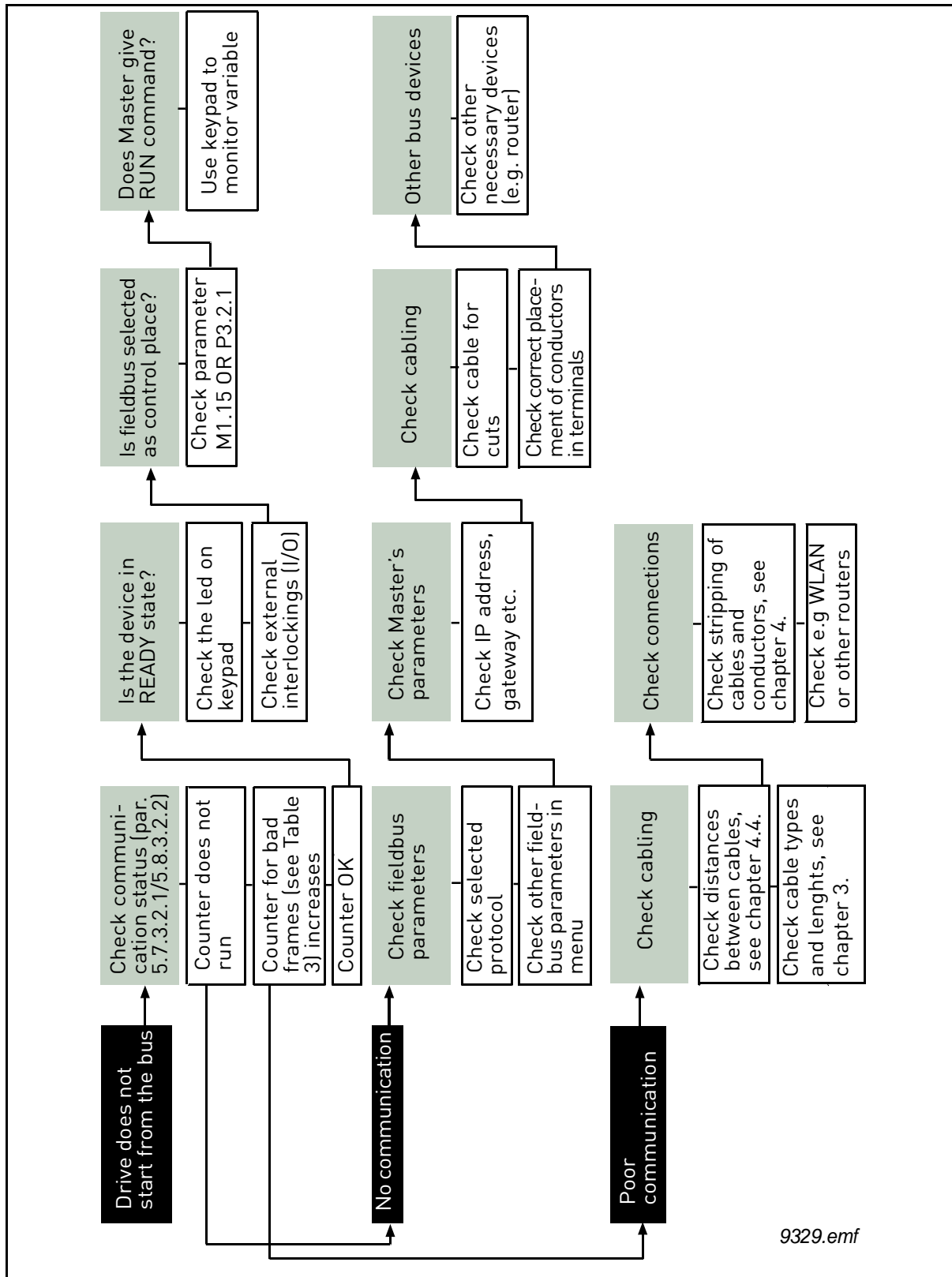

Figure 5. Fault tracing diagram for Modbus TCP

8. QUICK SETUP

Following these instructions, you can easily and fast set up your Modbus for use:

1	<p>Choose control place.</p> <p>A. Press LOC/REM button on keypad to select <i>Remote Control Place</i></p> <p>B. Select <i>Fieldbus</i> as remote control place: <i>Main Menu > Quick Setup (M1) > Rem. Ctrl. Place (P1.15) > FieldbusCTRL</i></p>
2	<p>Make these settings in the master software</p> <p>A. Set Control Word to '0' by writing the data 0000h to the register 2001_d.</p> <p>B. Set Control Word to '1' by writing the data 0001h to the register 2001_d.</p> <p>C. AC drive status is RUN</p> <p>D. Set Speed Reference value to '5000' (=50.00%) by writing the data 1388h to the register 2003_d.</p> <p>E. <i>Actual speed</i> is 5000 (25.00 Hz if MinFreq is 0.00 Hz and MaxFreq is 50.00 Hz)</p> <p>F. Set Control Word to '0' by writing the data 0000h to the register 2001_d.</p> <p>G. AC drive status is STOP.</p>

9. ANNEX

Process Data IN (Master to Slave)

Use of Process Data In variables depends on the used application. The configuration of the data is free.

Process Data OUT (Slave to Master)

Use of Process Data Out variables depends on the used application.

The Fieldbus Master can read the AC drive's actual values using process data variables. Control applications use process data as follows:

Table 50. Process Data OUT variables

Table 51.

2104	Process data OUT 1	1	Output Frequency	0.01 Hz
2105	Process data OUT 2	2	Motor Speed	1 rpm
2106	Process data OUT 3	3(45) ²	Motor Current	0.1 A
2107	Process data OUT 4	4	Motor Torque	0.1 %
2108	Process data OUT 5	5	Motor Power	0.1 %
2109	Process data OUT 6	6	Motor Voltage	0.1 V
2110	Process data OUT 7	7	DC link voltage	1 V
2111	Process data OUT 8	37	Active Fault Code	-

NOTE 1! In Vacon 100, the Motor Current scale depends on the drive size. In Vacon 100 HVAC the Motor Current scale is always 0.1 A.

NOTE 2! In Vacon 100 HVAC, the default ID is 45 meaning "Motor Current 1 Decimal". In Vacon 100, the default ID is 3 for Motor Current. The ID 45 can be mapped by the user to this variable also in Vacon 100.

VACON[®]

www.danfoss.com

Vacon Ltd
Member of the Danfoss Group
Runsorintie 7
65380 Vaasa
Finland

Document ID:



Rev. C

Sales code: DOC-INSMODBUS+DLUK