

VACON[®] 20 X
AC DRIVES

OPTBK
AS-INTERFACE OPTION BOARD

USER MANUAL

INDEX

Document code(Original Instructions): DPD01311A

Rev. A

Revision release date: 23.5.13

1. OPTBK AS-interface board	2
1.1 General	2
1.2 Technical data	3
1.2.1 AS-interface technical data	3
1.2.2 AS-i board layout and connections	5
1.2.3 Physical media	6
1.2.4 LED indications.....	7
1.3 Option board installation.....	8

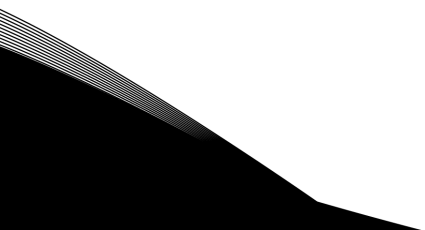

1. OPTBK AS-INTERFACE BOARD

1.1 GENERAL

AS-Interface,(AS-i) the Actuator sensor Interface is not an universal Fieldbus for all areas of automation, but rather an economically reasonable system for the lower field level. The AS-Interface is optimized to network binary sensors and actuators to the higher control level.

The AS-Interface, which is more an intelligent form of cabling than a true fieldbus, neither can nor intends to replace complex networks. But on the lower level of industrial communication, the Sensor/Actuator Level, the system stands out with its simple and cost-effective solutions. Cost-effective, rugged AS-Interface components are especially suited for use in harsh industrial environments. AS-i products are certified by the AS-International user organization guaranteeing worldwide compatibility. Vacon is AS-International member since January 2013.

Thanks to its simple, defined electromechanical interface the AS-Interface can be installed without the need for any special expertise. The "Snap and Go" cable penetration system has proven itself. The freely selectable network topology and ease of configuration make installation that much easier. Ease of assembly requiring little prior knowledge reduces downtime when faults occur.

The fault susceptibility of other systems often results in assembly delays, so the AS-Interface was consciously designed to reduce error sources. The special profile of the AS-Interface cable prevents reversal of the poles when connecting devices, and is just one example of the measures taken to reduce error frequency. Installation, a large cost factor, is drastically reduced by using the system. The low installation costs show the AS-Interface to be a technically and economically realistic solution to the normal fieldbus.

1.2 TECHNICAL DATA

VACON® frequency converters can be connected to the ASI bus system using a OPTBK field-bus board.



Internal components and circuit boards are at high potential when the frequency converter is connected to the power source. This voltage is extremely dangerous and may cause death or severe injury if you come into contact with it.



The relay outputs and other I/O-terminals may have a dangerous control voltage present even when the AC drive is disconnected from mains.



It is not allowed to add or replace option boards on a frequency converter with the power switched on. This may damage the boards.

NOTE! When experiencing problems with fieldbus functionalities, please contact Fieldbus@vacon.com.

1.2.1 AS-INTERFACE TECHNICAL DATA

Network type:	Master/Slave Communication System
	AS-Interface profile S-7.A.7 (AS-i specifications 3.0)
	IO code 7
	ID code A
	ID1 code 7
	ID2 code 7
Topology:	Very flexible with Line, Bus, Star or Tree Topology
Installation:	Special (yellow) unshielded cable with 2 wires providing data and 30 Volt power. Alternatively data and power on separate cables 100m length per Segment, extendible up to 300m with Repeaters
max. current consumption	150 mA
Data Rate :	167 kBit/s
max. Stations:	1 Master and up to 62 Slaves
Data :	each Slave: - 4 bit digital Input and 4 bit digital Output Data
Network Features :	Data values become refreshed at the slave in less than 21 ms; all 4 output bits operate simultaneously
User Organization :	AS-International

Table 1. AS-interface technical data

AS-interface is a simple master-to-slave structure. The master controls all time and network traffic. Protocol is embedded in the hardware. There are no configuration files to maintain. All

nodes are “AB Slaves”. Slaves have a maximum of 4 discrete input bits and 4 discrete output bits. The address range is 1A-31A and 1B-31B, with 0 being reserved for new incoming slaves. “0” is the default address set by manufacturers when a slave leaves the factory.

The board can be configured with the bits as the following table:

Parameter bits	
P0	Communication monitoring (Watchdog) P0 = 0 monitoring = off, the outputs maintain the status if communication fails (default setting) P0 = 1 monitoring = on, i.e. if communication fails, the outputs are deenergised
P1	Input filter P1 = 0 input filter on, pulse suppression (default setting) P1 = 1 input filter off
P2	Synchronous mode P2 = 0 synchronous mode on (default setting) P2 = 1 synchronous mode off
P3	Not used

Table 2. Description of parameter bit function.

1.2.2 AS-I BOARD LAYOUT AND CONNECTIONS

Both data and power are supplied on the two-wire cable. The DC power carries the AS-interface signal. The AS-interface signal and the voltage regulating circuitry of the power supply do not get along and must be separated. Different than most industrial buses, the AS-interface negative (ASI N) cannot be grounded. This is because the 2 wires carry both the power and the signal. Grounding the signal lines would result in poor communication, if not completely lost communication. Typical AS-interface media is not shielded. If an application does arise where shielding is required then the shield would be grounded in only one place. The original AS-interface power supply provided voltages in the 30VDC range. The actual specification was 29.5 to 31.6 volts DC. The reason for being higher than the industry standard nominal 24VDC was to compensate for the voltage drop on the line as well as the drop through the AS-interface IC chip.

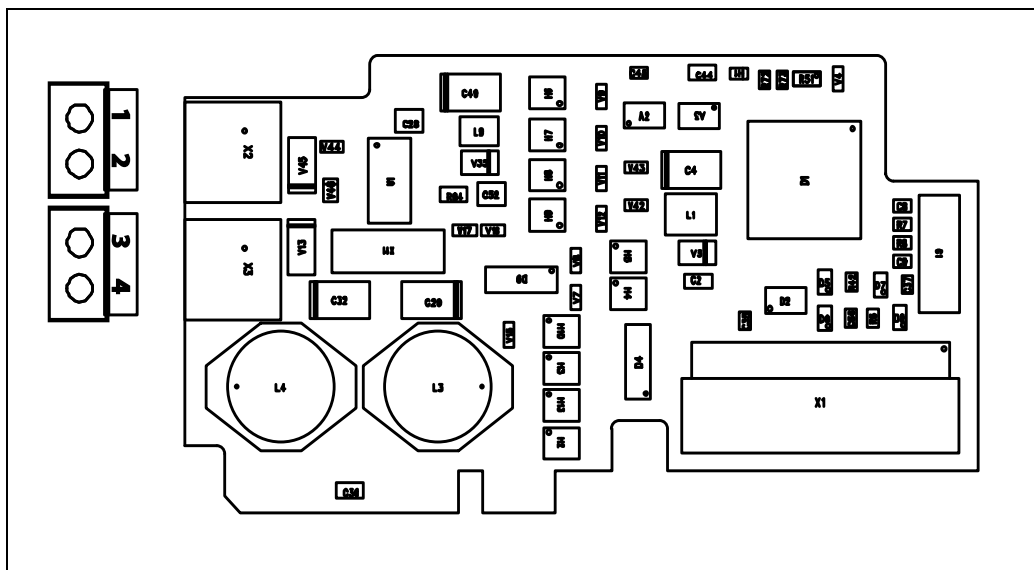

Figure 1. OPTBK AS-interface option board.

OPTBK AS-interface terminals		
Terminal	Signal	Technical information
1	ASI P	AS-interface +
2	ASI N	AS-interface -
3	ASI Supply P	Auxiliary output voltage (ASi voltage input - max 2,4V at maximum output current)
4	ASI Supply N	GND of Auxiliary output voltage

Table 3.

1.2.3 PHYSICAL MEDIA

AS-interface is available in both flat cable with IDC (Insulation Displacement Cable) connectors or round cable with industry standard M12 EN50 044 connectors.

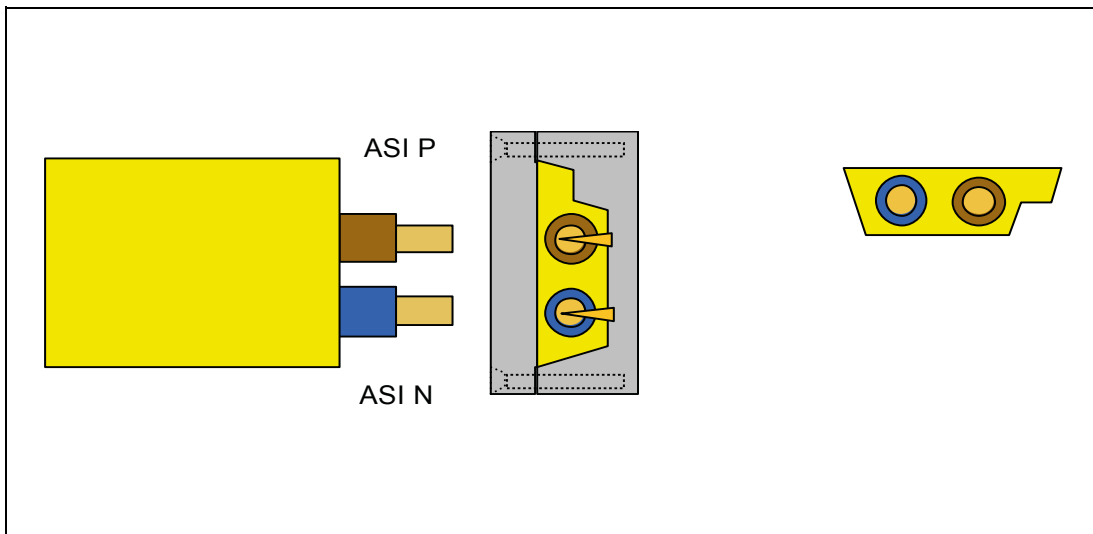

Figure 2. AS-interface Flat Cable. Right figure shown with piercing teeth.

Cross section of the wires	
EU	US
2 x 15 mm ²	2 x 18 AWG

Table 4. Cross sectional size of the wires.

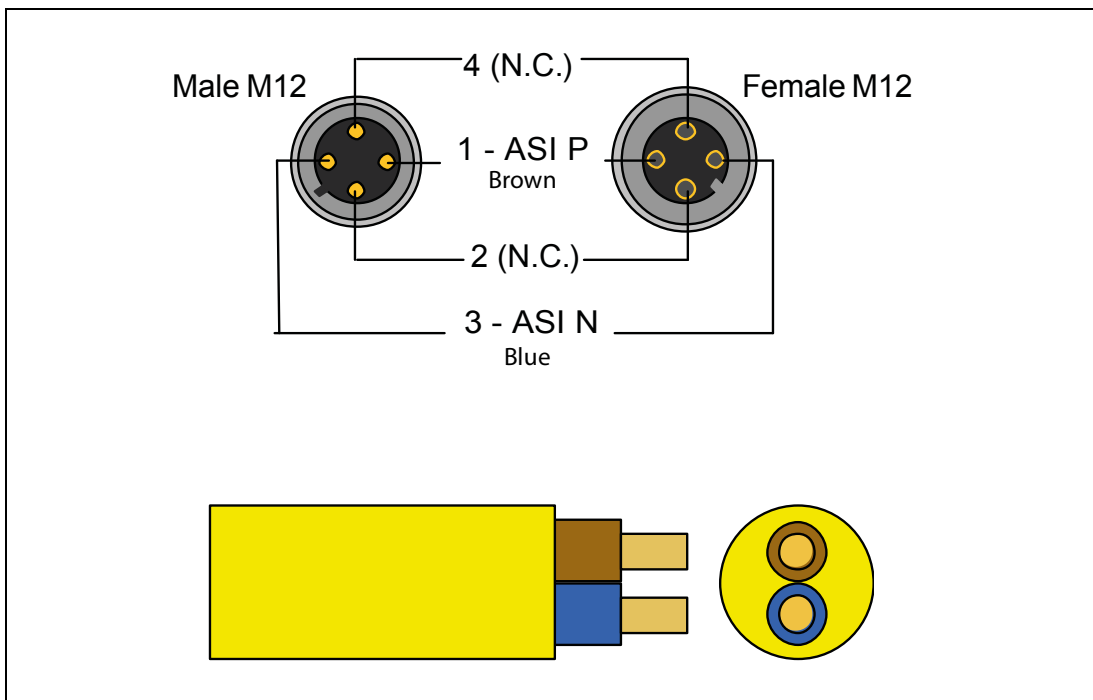

Figure 3. AS-interface round cable with industry standard M12 EN50 044 connector.

1.2.4 LED INDICATIONS

There are two LED indications next to the connector on the bottom side of the option board as show in the picture below.

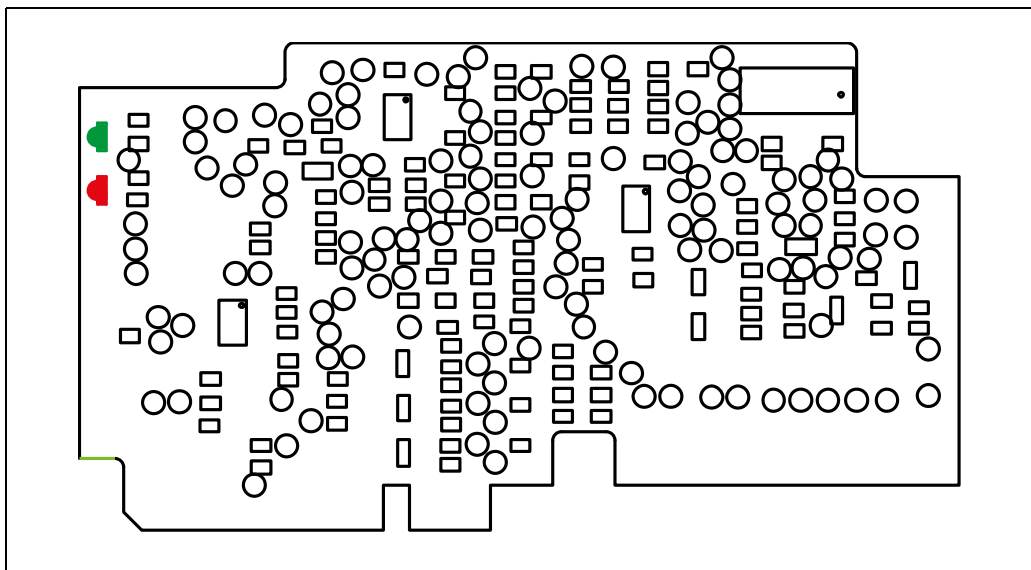

Figure 4. LED position on the option board.

LED indications			
Green LED is:	Red LED is:	Meaning	Note
OFF	OFF	Power OFF	No power supply available
ON	OFF	Normal Operation	Data communication is established
ON	ON	No data exchange	IC is waiting for a Write_Parameter request.
Flashing	ON	No data exchange (Address = 0)	Slave is waiting for address assignment. Data Port communication is not possible.
ON	Flashing	Periphery Fault	Communication Error

Table 5. LED indications.

1.3 OPTION BOARD INSTALLATION



NOTE! It is not allowed to add or replace option boards or fieldbus boards on an AC drive with the power switched on. This may damage the boards.

1

- Open the cover of the drive.

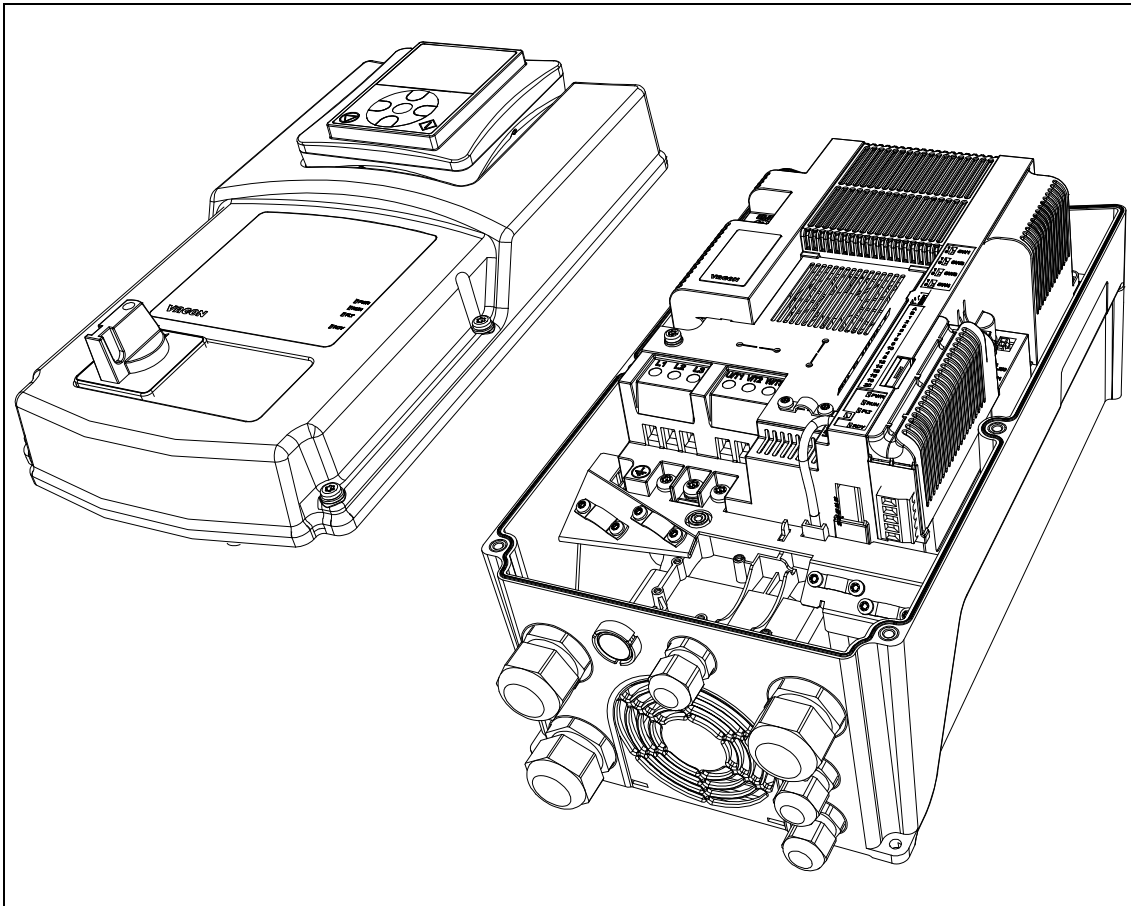

Figure 5. Opening the main cover, MU3 example.



The relay outputs and other I/O-terminals may have a dangerous control voltage present even when the drive is disconnected from mains.

2

- Remove the option slot cover.

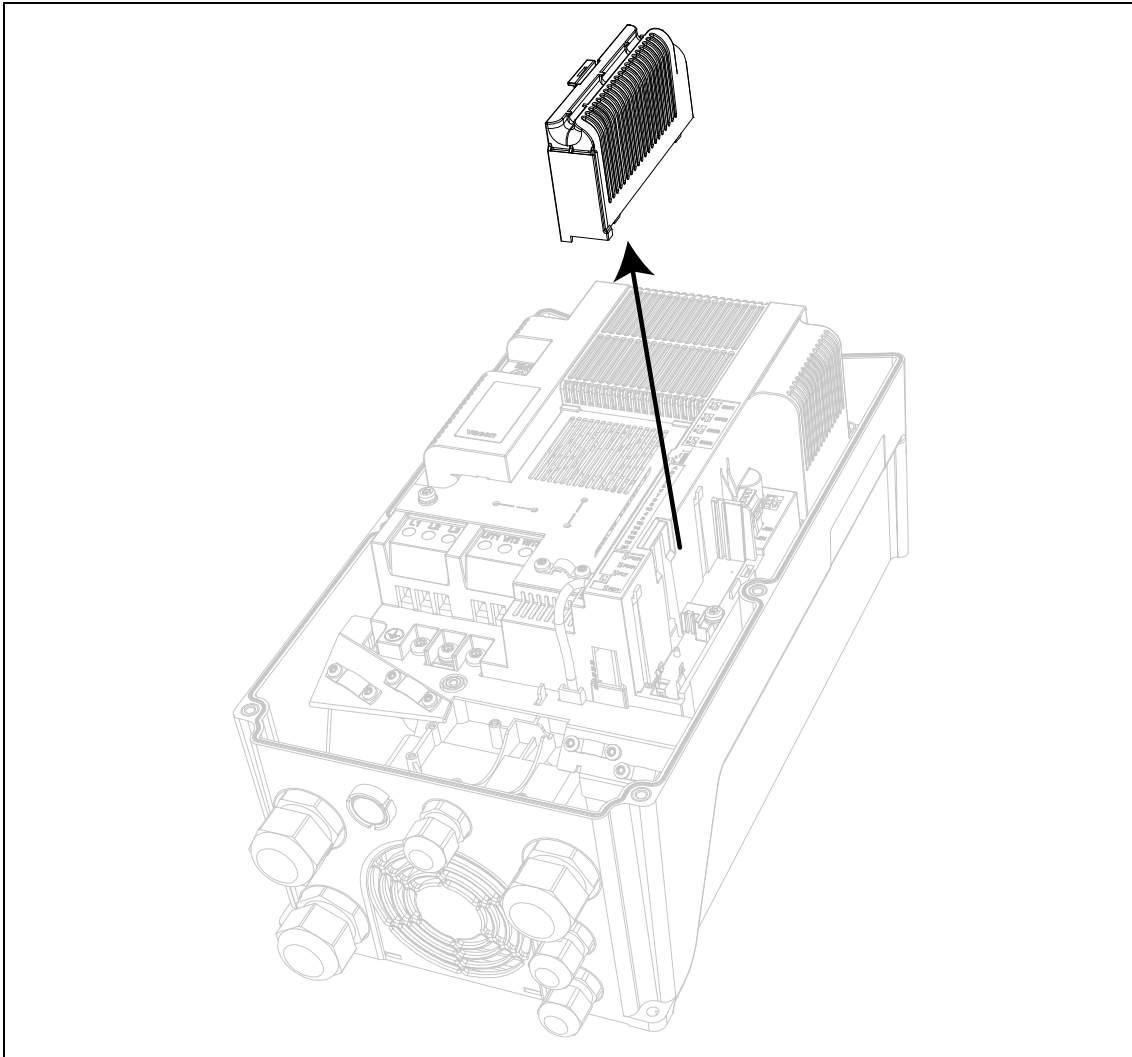

Figure 6. Removing the option slot cover.

3

- Make sure that the sticker on the connector of the board says “dv” (dual voltage). This indicates that the board is compatible with Vacon 20X. See below:

- **NOTE:** Incompatible boards cannot be installed on Vacon 20X. Compatible boards have a slot coding that enable the placing of the board (see above)

4

- Install the option board into the slot as shown in the picture below.

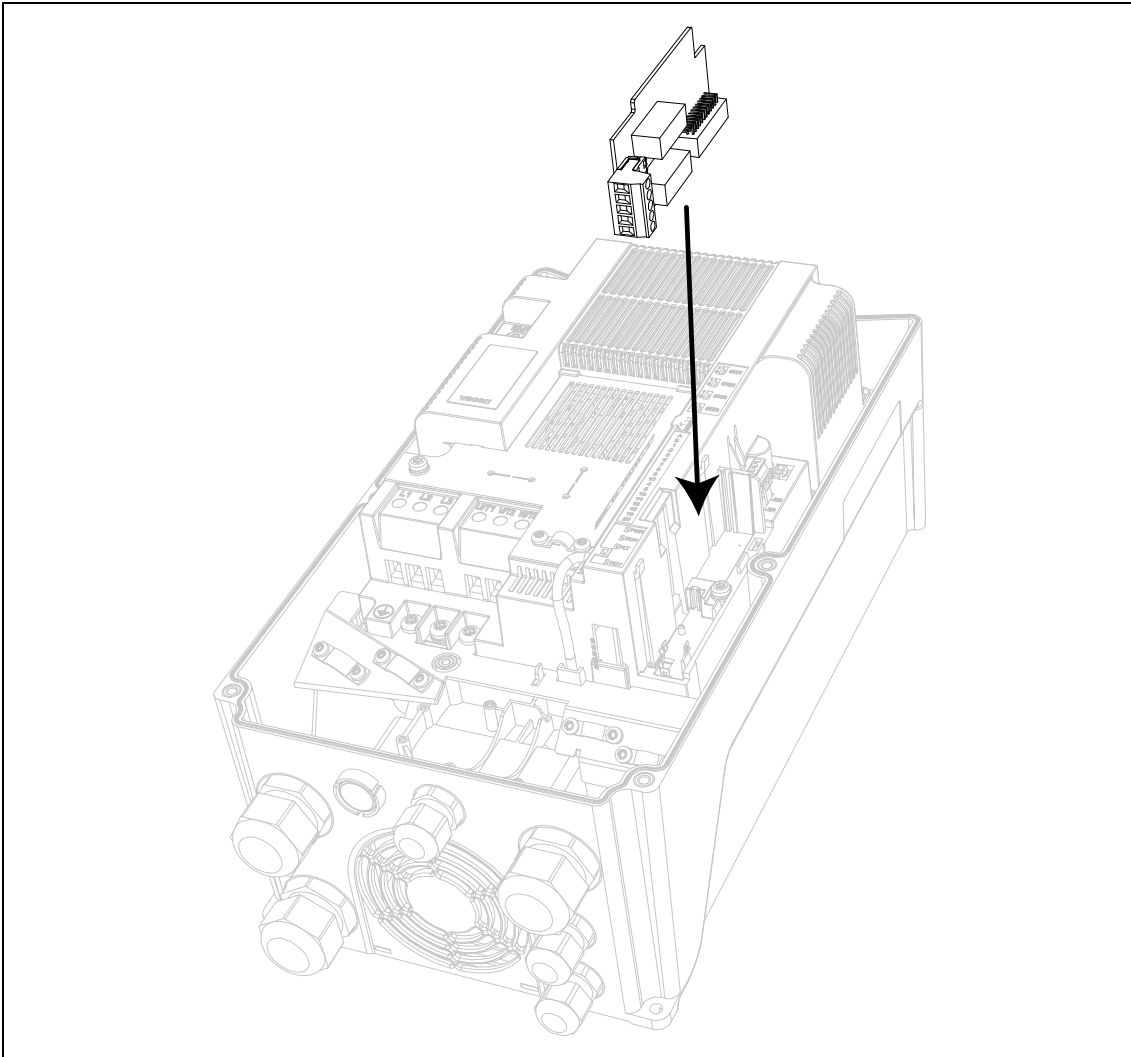

Figure 7. Option board installation.

5

- Mount the option slot cover.

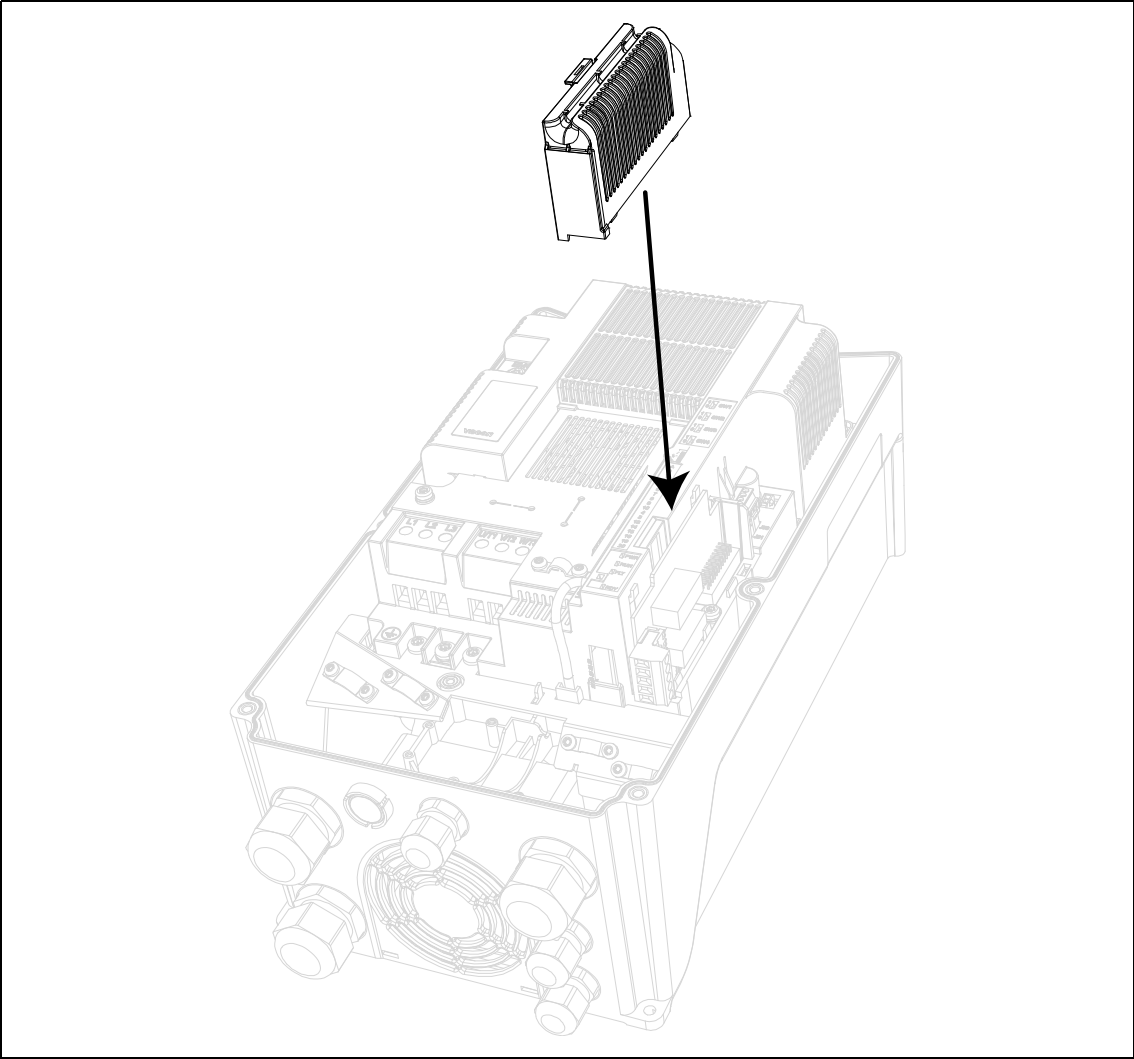

Figure 8. Mounting of option slot cover.

VACON[®]

DRIVEN BY DRIVES

Find your nearest Vacon office
on the Internet at:

www.vacon.com

Document ID:



Manual authoring:
documentation@vacon.com

Vacon Plc.
Runsorintie 7
65380 Vaasa
Finland

Subject to change without prior notice
© 2013 Vacon Plc.

Rev. A