

VACON[®] NX
AC DRIVES

**ALL IN ONE
APPLICATION MANUAL**

VACON[®]

PREFACE

Document ID: DPD00903F

Date: 14.8.2017

Software code:

- Basic Application = ASFIFF01
- Standard Application = ASFIFF02
- Local/Remote Control Application = ASFIFF03
- Multi-step Speed Control Application = ASFIFF04
- PID Control Application = ASFIFF05
- Multi-purpose Control Application
 - NXS = ASFIFF06
 - NXP = APFIFF06
- Pump and Fan Control Application = ASFIFF07

ABOUT THIS MANUAL

This manual is copyright of Vacon Ltd. All Rights Reserved. The manual is subject to change without prior notice. The original language of these instructions is English.

In this manual, you can read about the functions of the VACON® AC drive and how to use the drive.

This manual includes a large quantity of parameter tables. These instructions tell you how to read the tables.

A	B	C	D	E	F	G	H	I
Index	Parameter	Min	Max	Unit	Default	Cust	ID	Description

J

- | | |
|--|--|
| <p>A. The location of the parameter in the menu, that is, the parameter number.</p> <p>B. The name of the parameter.</p> <p>C. The minimum value of the parameter.</p> <p>D. The maximum value of the parameter.</p> <p>E. The unit of the value of the parameter. The unit shows if it is available.</p> <p>F. The value that was set in the factory.</p> | <p>G. The customer's own setting.</p> <p>H. The ID number of the parameter.</p> <p>I. A short description of the values of the parameter and/or its function.</p> <p>J. When the symbol shows, you can find more data about the parameter in Chapter Parameter descriptions.</p> |
|--|--|

NOTE! You can download the English and French product manuals with applicable safety, warning and caution information from <http://drives.danfoss.com/knowledge-center/technical-documentation/>.

REMARQUE Vous pouvez télécharger les versions anglaise et française des manuels produit contenant l'ensemble des informations de sécurité, avertissements et mises en garde applicables sur le site <http://drives.danfoss.com/knowledge-center/technical-documentation/>.

TABLE OF CONTENTS

Preface

About this manual	3
1 Basic Application	12
1.1 Introduction	12
1.1.1 Motor protection functions in the Basic Application	12
1.2 Control I/O	13
1.3 Control signal logic in Basic Application	15
1.4 Basic Application - Parameter lists	15
1.4.1 Monitoring values (Control keypad: Menu M1)	15
1.4.2 Basic parameters (Control keypad: Menu M2 -> G2.1)	17
1.4.3 Keypad control (Control keypad: Menu M3)	18
1.4.4 System menu (Control keypad: Menu M6)	19
1.4.5 Expander boards (Control keypad: Menu M7)	19
2 Standard Application	20
2.1 Introduction	20
2.2 Control I/O	21
2.3 Control signal logic in Standard Application	23
2.4 Standard Application - Parameter lists	23
2.4.1 Monitoring values (Control keypad: Menu M1)	23
2.4.2 Basic parameters (Control keypad: Menu M2 -> G2.1)	25
2.4.3 Input signals (Control keypad: Menu M2 -> G2.2)	26
2.4.4 Output signals (Control keypad: Menu M2 -> G2.3)	28
2.4.5 Drive control parameters (Control keypad: Menu M2 -> G2.4)	31
2.4.6 Prohibit frequency parameters (Control keypad: Menu M2 -> G2.5)	32
2.4.7 Motor control parameters (Control keypad: Menu M2 -> G2.6)	33
2.4.8 Protections (Control keypad: Menu M2 -> G2.7)	36
2.4.9 Autorestart parameters (Control keypad: Menu M2 -> G2.8)	38
2.4.10 Keypad control (Control keypad: Menu M3)	38
2.4.11 System menu (Control keypad: Menu M6)	39
2.4.12 Expander boards (Control keypad: Menu M7)	39
3 Local/Remote Control Application	40
3.1 Introduction	40
3.2 Control I/O	41

3.3	Control signal logic in Local/Remote Application	43
3.4	Local/Remote Control Application - Parameter lists	43
3.4.1	Monitoring values (Control keypad: Menu M1)	43
3.4.2	Basic parameters (Control keypad: Menu M2 -> G2.1)	45
3.4.3	Input signals (Control keypad: Menu M2 -> G2.2)	47
3.4.4	Output signals (Control keypad: Menu M2 -> G2.3)	51
3.4.5	Drive control parameters (Control keypad: Menu M2 -> G2.4)	55
3.4.6	Prohibit frequency parameters (Control keypad: Menu M2 -> G2.5)	56
3.4.7	Motor control parameters (Control keypad: Menu M2 -> G2.6)	57
3.4.8	Protections (Control keypad: Menu M2 -> G2.7)	60
3.4.9	Autorestart parameters (Control keypad: Menu M2 -> G2.8)	62
3.4.10	Keypad control (Control keypad: Menu M3)	62
3.4.11	System menu (Control keypad: Menu M6)	63
3.4.12	Expander boards (Control keypad: Menu M7)	63
4	Multi-step Speed Control Application	64
4.1	Introduction	64
4.2	Control I/O	65
4.3	Control signal logic in Multi-Step Speed Control Application	67
4.4	Multi-step Speed Control Application - Parameter lists	67
4.4.1	Monitoring values (Control keypad: Menu M1)	67
4.4.2	Basic parameters (Control keypad: Menu M2 -> G2.1)	69
4.4.3	Input signals (Control keypad: Menu M2 -> G2.2)	71
4.4.4	Output signals (Control keypad: Menu M2 -> G2.3)	74
4.4.5	Drive control parameters (Control keypad: Menu M2 -> G2.4)	78
4.4.6	Prohibit frequency parameters (Control keypad: Menu M2 -> G2.5)	79
4.4.7	Motor control parameters (Control keypad: Menu M2 -> G2.6)	80
4.4.8	Protections (Control keypad: Menu M2 -> G2.7)	83
4.4.9	Autorestart parameters (Control keypad: Menu M2 -> G2.8)	85
4.4.10	Keypad control (Control keypad: Menu M3)	85
4.4.11	System menu (Control keypad: Menu M6)	86
4.4.12	Expander boards (Control keypad: Menu M7)	86
5	PID Control Application	87
5.1	Introduction	87
5.2	Control I/O	88

5.3	Control signal logic in PID Control Application	90
5.4	PID Control Application - Parameter lists	90
5.4.1	Monitoring values (Control keypad: Menu M1)	90
5.4.2	Basic parameters (Control keypad: Menu M2 -> G2.1)	93
5.4.3	Input signals	95
5.4.4	Output signals (Control keypad: Menu M2 -> G2.3)	100
5.4.5	Drive control parameters (Control keypad: Menu M2 -> G2.4)	104
5.4.6	Prohibit frequency parameters (Control keypad: Menu M2 -> G2.5) ...	105
5.4.7	Motor control parameters (Control keypad: Menu M2 -> G2.6)	106
5.4.8	Protections (Control keypad: Menu M2 -> G2.7)	108
5.4.9	Autorestart parameters (Control keypad: Menu M2 -> G2.8)	110
5.4.10	Keypad control (Control keypad: Menu M3)	110
5.4.11	System menu (Control keypad: Menu M6)	111
5.4.12	Expander boards (Control keypad: Menu M7)	111
6	Multi-purpose Control Application	112
6.1	Introduction	112
6.2	Control I/O	114
6.3	Control signal logic in Multi-Purpose Control Application	116
6.4	Multi-purpose Control Application - Parameter lists	116
6.4.1	Monitoring values (Control keypad: Menu M1)	116
6.4.2	Basic parameters (Control keypad: Menu M2 -> G2.1)	130
6.4.3	Input signals	133
6.4.4	Output signals	140
6.4.5	Drive control parameters (Control keypad: Menu M2 -> G2.4)	148
6.4.6	Prohibit frequency parameters (Control keypad: Menu M2 -> G2.5) ...	150
6.4.7	Motor control parameters (Control keypad: Menu M2 -> G2.6)	151
6.4.8	Protections (Control keypad: Menu M2 -> G2.7)	159
6.4.9	Autorestart parameters (Control keypad: Menu M2 -> G2.8)	163
6.4.10	Fieldbus parameters (Control Keypad: Menu M2 ->G2.9)	164
6.4.11	Torque control parameters (Control Keypad: Menu M2 -> G2.10)	167
6.4.12	NXP drives: Master Follower parameters (Control keypad: Menu M2 -> G2.11)	169
6.4.13	Functional Safety (Control keypad: Menu M2 -> G2.12)	170
6.4.14	Keypad control (Control keypad: Menu M3)	170
6.4.15	System menu (Control keypad: Menu M6)	171
6.4.16	Expander boards (Control keypad: Menu M7)	171
7	Pump and Fan Control Application	172
7.1	Introduction	172
7.2	Control I/O	173

7.3	Control signal logic in Pump and Fan Control Application	177
7.4	Pump and Fan Control Application - Parameter lists	177
7.4.1	Monitoring values (Control keypad: Menu M1)	177
7.4.2	Basic parameters (Control keypad: Menu M2 -> G2.1)	180
7.4.3	Input signals	182
7.4.4	Output signals	188
7.4.5	Drive control parameters (Control keypad: Menu M2 -> G2.4)	195
7.4.6	Prohibit frequency parameters (Control keypad: Menu M2 -> G2.5) ...	196
7.4.7	Motor control parameters (Control keypad: Menu M2 -> G2.6)	197
7.4.8	Protections (Control keypad: Menu M2 -> G2.7)	198
7.4.9	Autorestart parameters (Control keypad: Menu M2 -> G2.8)	200
7.4.10	Pump and fan control parameters (Control keypad: Menu M2 -> G2.9)	201
7.4.11	Keypad control (Control keypad: Menu M3)	203
7.4.12	System menu (Control keypad: Menu M6)	203
7.4.13	Expander boards (Control keypad: Menu M7)	203
8	Monitoring value descriptions	204
9	Parameter descriptions	214
9.1	Keypad control parameters	363
9.2	Master/follower function (NXP only)	365
9.2.1	Master/follower link physical connections	365
9.2.2	Optical fibre connection between AC drives with OPTD2	365
9.3	External brake control with additional limits (IDs 315, 316, 346 to 349, 352, 353)	366
9.4	Parameters of motor thermal protection (IDs 704 to 708)	367
9.5	Parameters of stall protection (IDs 709 to 712)	368
9.6	Parameters of underload protection (IDs 713 to 716)	368
9.7	Fieldbus control parameters (IDs 850 to 859)	369
9.7.1	Process data out (slave -> master)	369
9.7.2	Current scaling in different size of units	369
9.7.3	Process data in (master -> slave)	370
9.8	Closed loop parameters (IDs 612 to 621)	371
9.9	"Terminal to function" (TTF) programming principle	372
9.9.1	Defining an input/output for a certain function on keypad	372
9.9.2	Defining a terminal for a certain function with NCDrive programming tool	373
9.9.3	Defining unused inputs/outputs	374
9.10	Speed control parameters (application 6 only)	375
9.11	Functional safety parameters (application 6 only)	377
9.12	Automatic changing between drives (application 7 only)	378
9.13	Interlock selection (P2.9.23)	380

9.14	Examples of Autochange and Interlock selection	381
9.14.1	Pump and fan automatics with interlocks and no autochange	381
9.14.2	Pump and fan automatics with interlocks and autochange	382
9.15	Fieldbus control in detail	385
9.15.1	Combination 2: ByPass - ProfiDrive	386
9.15.2	Combination 3: ByPass - Standard	388
10	Fault tracing	390
10.1	Fault codes	390

1 BASIC APPLICATION

1.1 INTRODUCTION

The Basic Application is a simple and easy-to-use application. It is the default setting on delivery from the factory. Otherwise select the Basic Application in menu M6 on page S6.2. See the product's User Manual.

Digital input DIN3 is programmable.

The parameters of the Basic Application are explained in Chapter 9 *Parameter descriptions* of this manual. The explanations are arranged according to the individual ID number of the parameter.

1.1.1 MOTOR PROTECTION FUNCTIONS IN THE BASIC APPLICATION

The Basic Application provides almost all the same protection functions as the other applications:

- External fault protection
- Input phase supervision
- Undervoltage protection
- Output phase supervision
- Earth fault protection
- Motor thermal protection
- Thermistor fault protection
- Fieldbus fault protection
- Slot fault protection

Unlike the other applications, the Basic Application does not provide any parameters for choosing the response function or limit values for the faults. For more information on the motor thermal protection, see ID704 in Chapter 9 *Parameter descriptions*.

1.2 CONTROL I/O

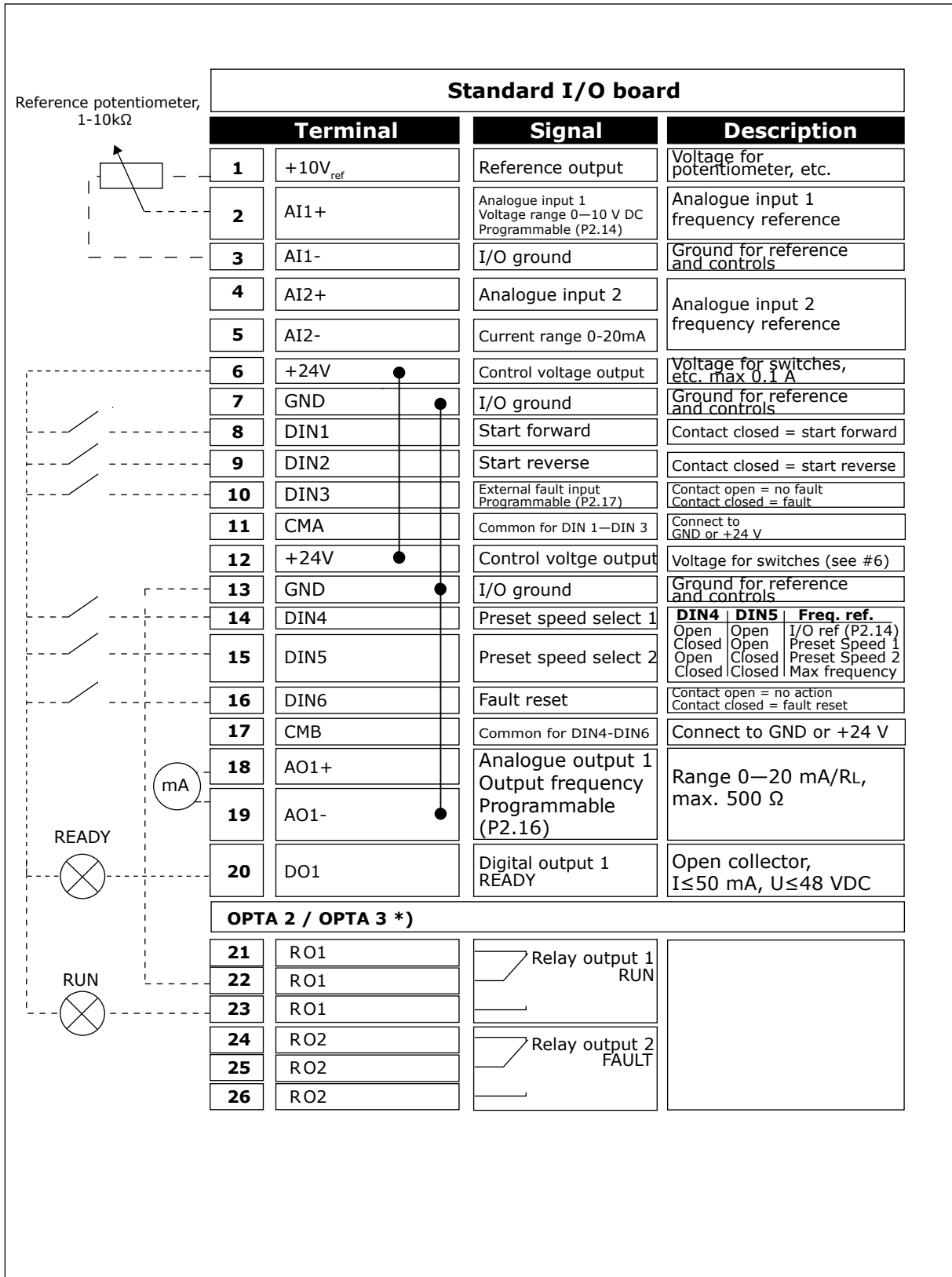

Fig. 1: Basic application default I/O configuration

*) The option board A3 has no terminal for open contact on its second relay output (terminal 24 is missing).



NOTE!

See jumper selections below. More information in the product's User Manual.

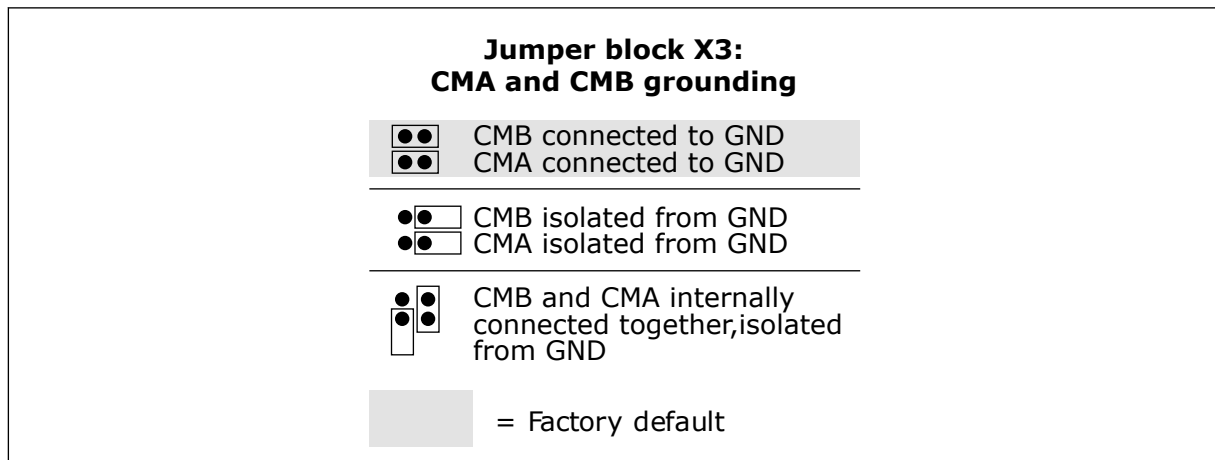

Fig. 2: Jumper selections

1.3 CONTROL SIGNAL LOGIC IN BASIC APPLICATION

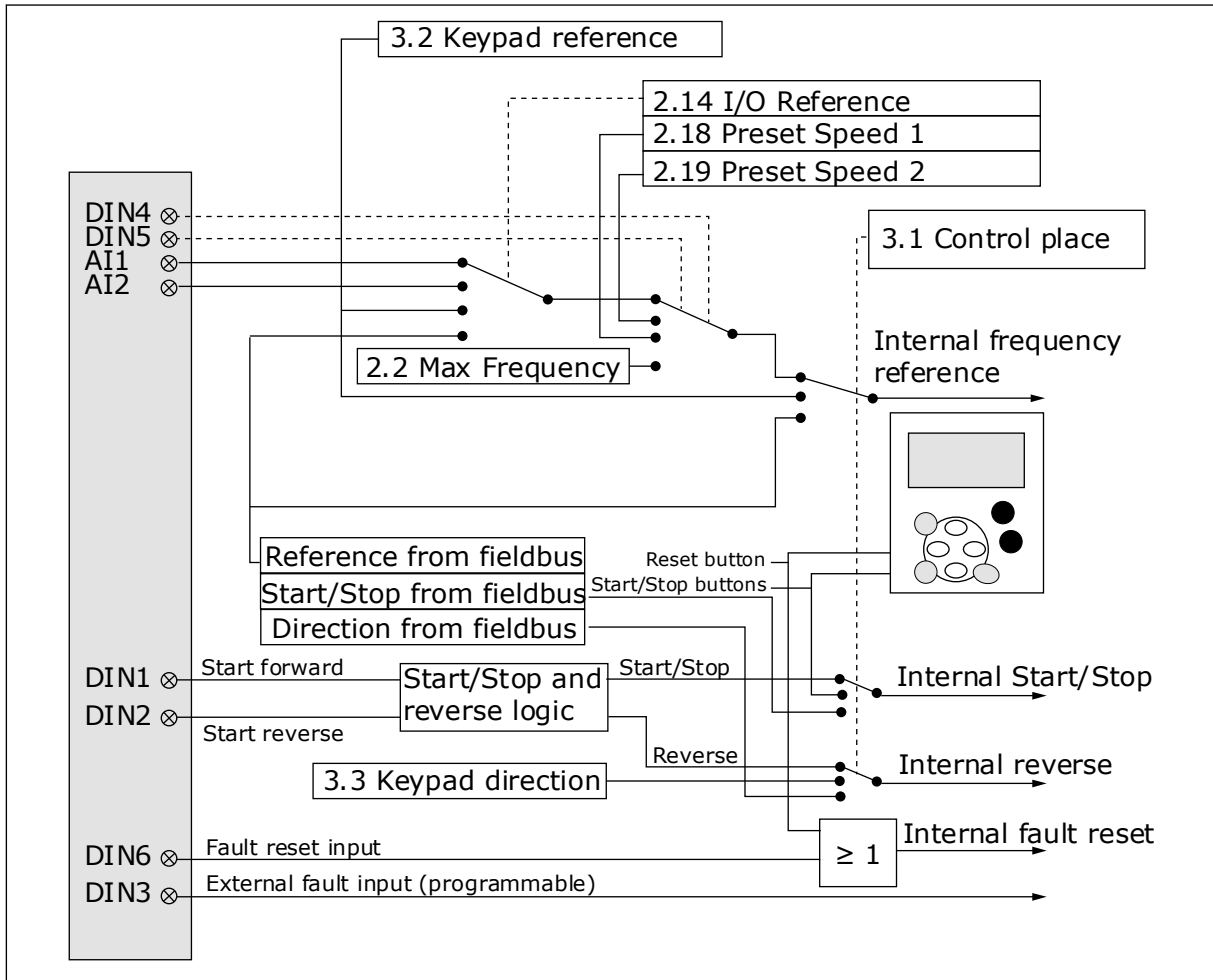

Fig. 3: Control signal logic of the Basic Application

1.4 BASIC APPLICATION - PARAMETER LISTS

1.4.1 MONITORING VALUES (CONTROL KEYPAD: MENU M1)

The monitoring values are the actual values of parameters and signals as well as statuses and measurements. Monitoring values cannot be edited.

Table 1: Monitoring values

Index	Monitoring value	Unit	Form	ID	Description
V1.1	Output frequency	Hz	###	1	
V1.2	Frequency reference	Hz	###	25	
V1.3	Motor speed	rpm	#	2	
V1.4	Motor current	A	Varies	3	
V1.5	Motor torque	%	##	4	
V1.6	Motor power	%	##	5	
V1.7	Motor voltage	V	##	6	
V1.8	DC link voltage	V	#	7	
1.9	Unit temperature	°C	#	8	
1.10	Motor temperature	%	##	9	
V1.11	Analogue input 1	V/mA	###	13	
V1.12	Analogue input 2	V/mA	###	14	
V1.13	DIN 1, 2, 3			15	
V1.14	DIN 4, 5, 6			16	
V1.15	D01, R01, R02			17	
V1.16	Analogue lout	mA	###	26	
V1.17	Multimonitoring items				

1.4.2 BASIC PARAMETERS (CONTROL KEYPAD: MENU M2 -> G2.1)

Table 2: Basic parameters G2.1

Index	Parameter	Min	Max	Unit	Default	Cust	ID	Description
P2.1	Min frequency	0.00	P2.2	Hz	0.00		101	
P2.2	Max frequency	P2.1	320.00	Hz	50.00		102	
P2.3	Acceleration time 1	0.1	3000.0	s	3.0		103	
P2.4	Deceleration time 1	0.1	3000.0	s	3.0		104	
P2.5	Current limit	0.1 x IH	2 x IH	A	IL		107	
P2.6	Nominal voltage of the motor	180	690	V	NX2: 230V NX5: 400V NX6: 690V		110	
P2.7	Nominal frequency of the motor	8.00	320.00	Hz	50.00		111	
P2.8	Nominal speed of the motor	24	20 000	rpm	1440		112	
P2.9	Nominal current of the motor	0.1 x IH	2 X IH	A	IH		113	
P2.10	Motor cos phi	0.30	1.00		0.85		120	
P2.11	Start function	0	2		0		505	0 = Ramp 1 = Flying start 2 = Conditional flying start
P2.12	Stop function	0	3		0		506	0 = Costing 1 = 2 = Ramp + Run enable coast Ramp 3 = Coast + Run enable ramp
P2.13	U/f optimisation	0	1		0		109	0 = Not used 1 = Automatic torque boost
P2.14	I/O reference	0	3		0		117	0 = AI1 1 = AI2 2 = Keypad 3 = Fieldbus

Table 2: Basic parameters G2.1

Index	Parameter	Min	Max	Unit	Default	Cust	ID	Description
P2.15	Analogue input 2, reference offset	0	1		1		302	0 = 0-20 mA 1 = 4 mA-20mA
P2.16	Analogue output function	0	8		1		307	0 = Not used 1 = Output freq. (0-fmax) 2 = Freq. reference (0-fmax) 3 = Motor speed (0-Motor nominal speed) 4 = Output current (0-InMotor) 5 = Motor torque (0-TnMotor) 6 = Motor power (0-PnMotor) 7 = Motor voltage (0-UnMotor) 8 = DC-link volt (0-1000V)
P2.17	DIN3 function	0	7		1		301	0 = Not used 1 = Ext. fault, closing cont. 2 = Ext. fault, opening cont. 3 = Run enable, cc 4 = Run enable, oc 5 = Force cp. to IO 6 = Force cp. to keypad 7 = Force cp. to fieldbus
P2.18	Preset speed 1	0.00	P2.2	Hz	0.00		105	
P2.19	Preset speed 2	0.00	P2.2	Hz	50.00		106	
P2.20	Automatic restart	0	1		0		731	0 = Disabled 2 = Enabled

1.4.3 KEYPAD CONTROL (CONTROL KEYPAD: MENU M3)

The parameters for the selection of control place and direction on the keypad are listed below. See the Keypad control menu in the product's User Manual.

Table 3: Keypad control parameters, M3

Index	Parameter	Min	Max	Unit	Default	Cust	ID	Description
P3.1	Control place	1	3		1		125	1 = I/O terminal 2 = Keypad 3 = Fieldbus
P3.2	Keypad reference	P2.1	P2.2	Hz	0.00			
P3.3	Direction (on keypad)	0	1		0		123	
R3.4	Stop button	0	1		1		114	0 = Limited function of Stop button 1 = Stop button always enabled

1.4.4 SYSTEM MENU (CONTROL KEYPAD: MENU M6)

For parameters and functions related to the general use of the AC drive, such as application and language selection, customised parameter sets or information about the hardware and software, see the product's User Manual.

1.4.5 EXPANDER BOARDS (CONTROL KEYPAD: MENU M7)

The M7 menu shows the expander and option boards attached to the control board and board related information. For more information, see the product's User Manual.

2 STANDARD APPLICATION

2.1 INTRODUCTION

Select the Standard Application in menu M6 on page S6.2.

The Standard Application is typically used in pump and fan applications and conveyors for which the Basic Application is too limited but where no special features are needed.

- The Standard Application has the same I/O signals and the same control logic as the Basic Application.
- Digital input DIN3 and all the outputs are freely programmable.

Additional functions:

- Programmable Start/Stop and Reverse signal logic
- Reference scaling
- One frequency limit supervision
- Second ramps and S-shape ramp programming
- Programmable start and stop functions
- DC-brake at stop
- One prohibit frequency area
- Programmable U/f curve and switching frequency
- Autorestart
- Motor thermal and stall protection: Programmable action; off, warning, fault

The parameters of the Standard Application are explained in Chapter 9 *Parameter descriptions* of this manual. The explanations are arranged according to the individual ID number of the parameter.

2.2 CONTROL I/O

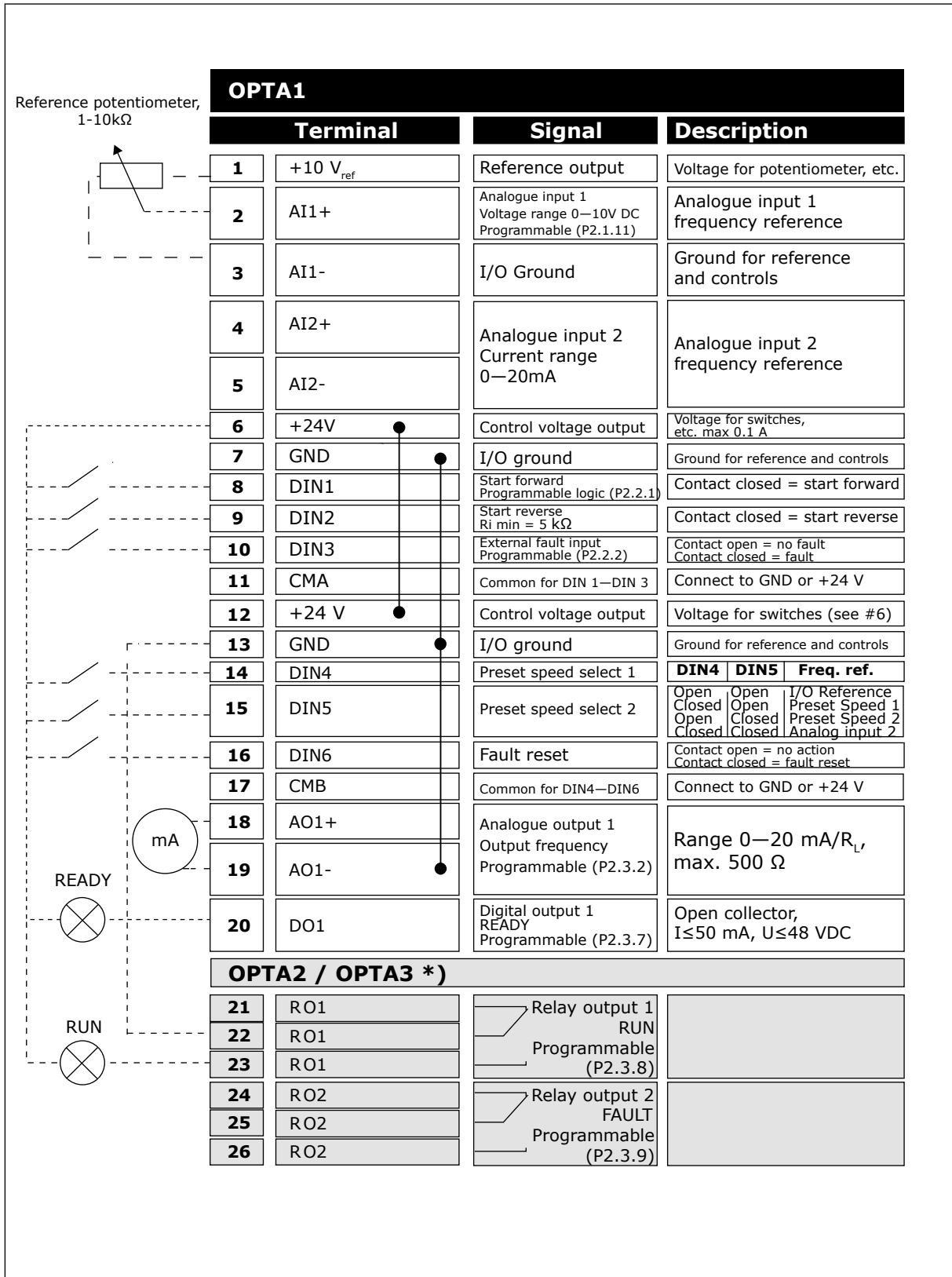

Fig. 4: Standard application default I/O configuration

*) The option board A3 has no terminal for open contact on its second relay output (terminal 24 is missing).

**NOTE!**

See jumper selections below. More information in the product's User Manual.

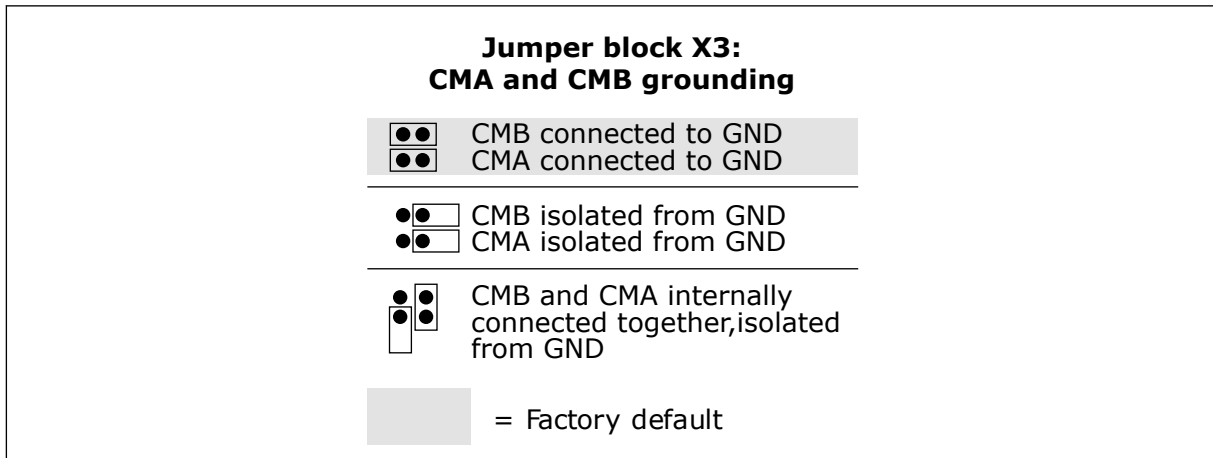

Fig. 5: Jumper selections

2.3 CONTROL SIGNAL LOGIC IN STANDARD APPLICATION

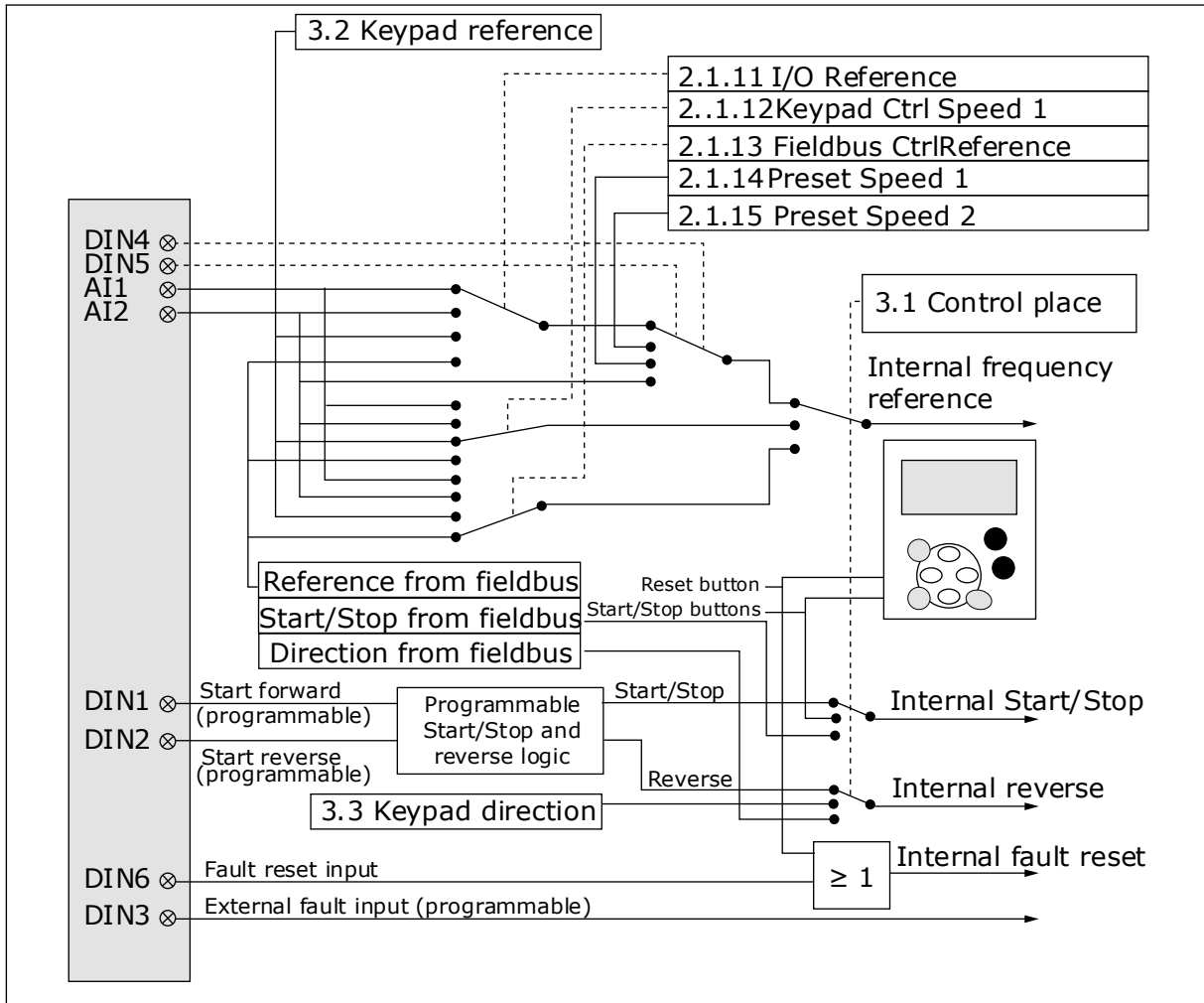

Fig. 6: Control signal logic of the Standard Application

2.4 STANDARD APPLICATION - PARAMETER LISTS

2.4.1 MONITORING VALUES (CONTROL KEYPAD: MENU M1)

The monitoring values are the actual values of parameters and signals as well as statuses and measurements. Monitoring values cannot be edited.

Table 4: Monitoring values

Index	Monitoring value	Unit	Form	ID	Description
V1.1	Output frequency	Hz	###	1	
V1.2	Frequency reference	Hz	###	25	
V1.3	Motor speed	rpm	#	2	
V1.4	Motor current	A	Varies	3	
V1.5	Motor torque	%	##	4	
V1.6	Motor power	%	##	5	
V1.7	Motor voltage	V	##	6	
V1.8	DC link voltage	V	#	7	
1.9	Unit temperature	°C	#	8	
1.10	Motor temperature	%	##	9	
V1.11	Analogue input 1	V/mA	###	13	
V1.12	Analogue input 2	V/mA	###	14	
V1.13	DIN 1, 2, 3			15	
V1.14	DIN 4, 5, 6			16	
V1.15	D01, R01, R02			17	
V1.16	Analogue lout	mA	###	26	
V1.17	Multimonitoring items				

2.4.2 BASIC PARAMETERS (CONTROL KEYPAD: MENU M2 -> G2.1)

Table 5: Basic parameters G2.1

Index	Parameter	Min	Max	Unit	Default	Cust	ID	Description
P2.1.1	Min frequency	0.00	P2.1.2	Hz	0.00		101	
P2.1.2	Max frequency	P2.1.1	320.00	Hz	50.00		102	
P2.1.3	Acceleration time 1	0.1	3000.0	s	0.0		103	
P2.1.4	Deceleration time 1	0.1	3000.0	s	0.0		104	
P2.1.5	Current limit	0.1 x IH	2 x IH	A	IL		107	
P2.1.6	Nominal voltage of the motor	180	690	V	NX2: 230V NX5: 400V NX6: 690V		110	
P2.1.7	Nominal frequency of the motor	8.00	320.00	Hz	50.00		111	
P2.1.8	Nominal speed of the motor	24	20 000	rpm	1440		112	
P2.1.9	Nominal current of the motor	0.1 x IH	2 X IH	A	IH		113	
P2.1.10	Motor cos phi	0.30	1.00		0.85		120	
P2.1.11	I/O reference	0	3		0		117	0 = AI1 1 = AI2 2 = Keypad 3 = Fieldbus
P2.1.12	Keypad control reference	0	3		2		121	0 = AI1 1 = AI2 2 = Keypad 3 = Fieldbus
P2.1.13	Fieldbus control reference	0	3		3		122	0 = AI1 1 = AI2 2 = Keypad 3 = Fieldbus
P2.1.14	Preset speed 1	0.00	P2.1.2	Hz	10.00		105	
P2.1.15	Preset speed 2	0.00	P2.1.2	Hz	50.00		106	

2.4.3 INPUT SIGNALS (CONTROL KEYPAD: MENU M2 -> G2.2)

Table 6: Input signals, G2.2

Index	Parameter	Min	Max	Unit	Default	Cust	ID	Description
P2.2.1	Start/Stop logic	0	6		0		300	<p>Logic = 0 Ctrl sgn 1 = Start forward Ctrl sgn 2 = Start reverse</p> <p>Logic = 1 Ctrl sgn 1 = Start/Stop Ctrl sgn 2 = Reverse</p> <p>Logic = 2 Ctrl sgn 1 = Start/Stop Ctrl sgn 2 = Run enable</p> <p>Logic = 3 Ctrl sgn 1 = Start pulse (edge) Ctrl sgn 2 = Stop pulse</p> <p>Logic = 4 Ctrl sgn 1 = Forward pulse (edge) Ctrl sgn 2 = Reverse pulse (edge)</p> <p>Logic = 5 Ctrl sgn 1 = Start pulse (edge) Ctrl sgn 2 = Reverse pulse</p> <p>Logic = 6 Ctrl sgn 1 = Start pulse (edge) Ctrl sgn 2 = Enable pulse</p>
P2.2.2	DIN3 function	0	8		1		301	<p>0 = Not used 1 = Ext. fault, closing cont. 2 = Ext. fault, opening cont. 3 = Run enable 4 = Acc./Dec. time select. 5 = Force cp. to IO 6 = Force cp. to keypad 7 = Force cp. to field-bus 8 = Reverse</p>

Table 6: Input signals, G2.2

Index	Parameter	Min	Max	Unit	Default	Cust	ID	Description
P2.2.3	Analogue input 2 reference offset	0	1		1		302	0 = 0-20 mA (0-10 V) ** 1 = 4-20 mA (2-10 V) **
P2.2.4	Reference scaling minimum value	0.00	320.00	Hz	0.00		303	
P2.2.5	Reference scaling maximum value	0.00	320.00	Hz	0.00		304	
P2.2.6	Reference inversion	0	1		0		305	0 = Not inverted 1 = Inverted
P2.2.7	Reference filter time	0.00	10.00	s	0.10		306	0 = No filtering
P2.2.8 ***	AI1 signal selection				A1		377	
P2.2.9 ***	AI2 signal selection				A2		388	

** = Remember to place jumpers of block X2 accordingly. See the product's User Manual.

*** = Use TTF method to program these parameters.

2.4.4 OUTPUT SIGNALS (CONTROL KEYPAD: MENU M2 -> G2.3)

Table 7: Output signals, G2.3

Index	Parameter	Min	Max	Unit	Default	Cust	ID	Description
P2.3.1	Analogue output 1 signal selection	0			A.1		464	
P2.3.2	Analogue output function	0	8		1		307	0 = Not used (20 mA/10V) 1 = Output freq. (0-fmax) 2 = Freq. reference (0-fmax) 3 = Motor speed (0-Motor nominal speed) 4 = Motor current (0-InMotor) 5 = Motor torque (0-TnMotor) 6 = Motor power (0-PnMotor) 7 = Motor voltage (0-UnMotor) 8 = DC-link volt (0-1000V)
P2.3.3	Analogue output filter time	0.00	10.00	s	1.00		308	0 = No filtering
P2.3.4	Analogue output inversion	0	1		0		309	0 = Not inverted 1 = Inverted
P2.3.5	Analogue output minimum	0	1		0		310	0 = 0 mA (0 V) 1 = 4 mA (2 V)
P2.3.6	Analogue output scale	10	1000	%	100		311	

Table 7: Output signals, G2.3

Index	Parameter	Min	Max	Unit	Default	Cust	ID	Description
P2.3.7	Digital output 1 function	0	16		1		312	0 = Not used 1 = Ready 2 = Run 3 = Fault 4 = Fault inverted 5 = FC overheat warning 6 = Ext. fault or warning 7 = Ref. fault or warning 8 = Warning 9 = Reversed 10 = Preset speed 1 11 = At speed 12 = Mot. regulator active 13 = OP freq. limit 1 superv. 14 = Control place: IO 15 = Therminstor fault/warning 16 = Fieldbus DIN1
P2.3.8	R01 function	0	16		2		313	As parameter 2.3.7
P2.3.9	R02 function	0	16		3		314	As parameter 2.3.7
P2.3.10	Output frequency limit 1 supervision	0	2		0		315	0 = No limit 1 = Low limit supervision 2 = High limit supervision
P2.3.11	Output frequency limit 1; Supervised value	0.00	320.00	Hz	0.00		316	
P2.3.12 *	Analogue output 2 signal selection	0.1	E.10		0.1		471	
P2.3.13	Analogue output 2 function	0	8		4		472	As parameter 2.3.2
P2.3.14	Analogue output 2 filter time	0.00	10.00	s	1.00		473	0 = No filtering
P2.3.15	Analogue output 2 inversion	0	1		0		474	0 = Not inverted 1 = Inverted
P2.3.16	Analogue output 2 minimum	0	1		0		475	0 = 0 mA [0 V] 1 = 4 mA [2 V]

Table 7: Output signals, G2.3

Index	Parameter	Min	Max	Unit	Default	Cust	ID	Description
P.2.3.17	Analogue output 2 scaling	10	1000	%	1.00		476	

* = Use TTF method to program these parameters.

2.4.5 DRIVE CONTROL PARAMETERS (CONTROL KEYPAD: MENU M2 -> G2.4)

Table 8: Drive control parameters, G2.4

Index	Parameter	Min	Max	Unit	Default	Cust	ID	Description
P2.4.1	Ramp 1 shape	0.0	10.0	s	0.1		500	0 = Linear 100 = full acc/dec inc/dec times
P2.4.2	Ramp 2 shape	0.0	10.0	s	0.0		501	0 = Linear 100 = full acc/dec inc/dec times
P2.4.3	Acceleration time 2	0.1	3000.0	s	1.0		502	
P2.4.4	Deceleration time 2	0.1	3000.0	s	1.0		503	
P2.4.5	Brake chopper	0	4		0		504	0 = Disabled 1 = Used when running 2 = External brake chopper 3 = Used when stopped/running 4 = used when run- ning (no testing)
P2.4.6	Start function	0	2		0		505	0 = Ramp 1 = Flying start 2 = Conditional fly- ing start
P2.4.7	Stop function	0	3		0		506	0 = Coasting 1 = Ramp 2 = Ramp+Run enable coast 3 = Coast+Run enable ramp
P2.4.8	DC braking cur- rent	0.00	IL	A	0.7 x IH		507	
P2.4.9	DC braking time at stop	0.00	600.00	s	0.00		508	0 = DC brake is off at stop
P2.4.10	Frequency to start DC braking during ramp stop	0.10	10.00	Hz	1.50		515	
P2.4.11	DC braking time at start	0.00	600.00	s	0.00		516	0 = DC brake is off at start
P2.4.12 *	Flux brake	0	1		0		520	0 = Off 0 = On

Table 8: Drive control parameters, G2.4

Index	Parameter	Min	Max	Unit	Default	Cust	ID	Description
P2.4.13	Flux braking current	0.00	IL	A	IH		519	

2.4.6 PROHIBIT FREQUENCY PARAMETERS (CONTROL KEYPAD: MENU M2 -> G2.5)**Table 9: Prohibit frequency parameters, G2.5**

Index	Parameter	Min	Max	Unit	Default	Cust	ID	Description
P2.5.1	Prohibit frequency range 1 low limit	0.00	320.00	Hz	0.00		509	
P2.5.2	Prohibit frequency range 1 high limit	0.00	320.00	Hz	0.00		510	
P2.5.3	Prohibit acc./dec. ramp	0.1	10.0	x	1.0		518	

2.4.7 MOTOR CONTROL PARAMETERS (CONTROL KEYPAD: MENU M2 -> G2.6)

Table 10: Motor control parameters, G2.6

Index	Parameter	Min	Max	Unit	Default	Cust	ID	Description
P2.6.1 *	Motor control mode	0	1/3		0		600	0 = Frequency control 1 = Speed control NXP: 2 = Open loop torque control 3 = Closed loop speed ctrl 4 = Closed loop torque control
P2.6.2 *	U/f optimisation	0	1		0		109	0 = Not used 1 = Automatic torque boost
P2.6.3 *	U/f ratio selection	0	3		0		108	0 = Linear 1 = Squared 2 = Programmable 3 = Linear with flux optim.
P2.6.4 *	Field weakening point	8.00	320.00	Hz	50.00		602	
P2.6.5 *	Voltage at field weakening point	10.00	200.00	%	100.00		603	
P2.6.6 *	U/f curve midpoint frequency	0.00	P2.6.4	Hz	50.00		604	
P2.6.7 *	U/f curve midpoint voltage	0.00	100.00	%	100.00		605	
P2.6.8 *	Output voltage at zero frequency	0.00	40.00	%	Varies		606	
P2.6.9	Switching frequency	1.0	Varies	kHz	Varies		601	
P2.6.10	Overvoltage controller	0	2		1		607	0 = Not used 1 = Used (no ramping) 2 = Used (ramping)
P2.6.11	Undervoltage controller	0	1		1		608	0 = Not used 1 = Used 2 = Used (ramping to zero)
P2.6.12	Load drooping	0.00	100.00	%	0.00		620	

Table 10: Motor control parameters, G2.6

Index	Parameter	Min	Max	Unit	Default	Cust	ID	Description
P2.6.13	Identification	0	1/2		0		631	0 = No action 1 = Identification w/o run 2 = Identification with run 3 = Encoder ID run 4 = No action 5 = ID Run Failed
Closed Loop parameter group 2.6.14								
P2.6.14.1	Magnetizing current	0.00	2 x IH	A	0.00		612	
P2.6.14.2	Speed control P gain	1	1000		30		613	
P2.6.14.3	Speed control I time	0.0	3200.0	ms	30.0		614	
P2.6.14.5	Acceleration compensation	0.00	300.00	s	0.00		626	
P2.6.14.6	Slip adjust	0	500	%	100		619	
P2.6.14.7	Magnetizing current at start	0,00	IL	A	0.00		627	
P2.6.14.8	Magnetizing time at start	0	60000	ms	0		628	
P2.6.14.9	0-speed time at start	0	32000	ms	100		615	
P2.6.14.10	0-speed time at stop	0	32000	ms	100		616	
P2.6.14.11	Start-up torque	0	3		0		621	0 = Not used 1 = Torque memory 2 = Torque reference 3 = Start-up torque fwd/rev
P2.6.14.12	Start-up torque FWD	-300.0	300.0	%	0.0		633	
P2.6.14.13	Start-up torque REV	-300.0	300.0	%	0.0		634	
P2.6.14.15	Encoder filter time	0.0	100.0	ms	0.0		618	

Table 10: Motor control parameters, G2.6

Index	Parameter	Min	Max	Unit	Default	Cust	ID	Description
P2.6.14.17	Current control P gain	0.00	100.00	%	40.00		617	
Identification parameter group 2.6.15								
P2.6.15.1	Speed step	-50.0	50.0	0.0	0.0		1252	

* = Parameter value can only be changed after the AC drive has been stopped.

2.4.8 PROTECTIONS (CONTROL KEYPAD: MENU M2 -> G2.7)

Table 11: Protections, G2.7

Index	Parameter	Min	Max	Unit	Default	Cust	ID	Description
P2.7.1	Response to 4 mA reference fault	0	5		0		700	0 = No response 1 = Warning 2 = Warning+Previous Freq. 3 = Wrng+Preset-Freq 2.7.2 4 = Fault, stop acc. to 2.4.7 5 = Fault, stop by coasting
P2.7.2	4 mA reference fault frequency	0.00	P2.1.2	Hz	0.00		728	
P2.7.3	Response to external fault	0	3		2		701	0 = No response 1 = Warning 2 = Fault, stop acc. to 2.4.7
P2.7.4	Input phase supervision	0	3		0		730	3 = Fault, stop by coasting
P2.7.5	Response to undervoltage fault	0	1		0		727	0 = Fault stored in history Fault not stored
P2.7.6	Output phase supervision	0	3		2		702	0 = No response 1 = Warning 2 = Fault, stop acc. to 2.4.7
P2.7.7	Earth fault protection	0	3		2		703	3 = Fault, stop by coasting
P2.7.8	Thermal protection of the motor	0	3		2		704	
P2.7.9	Motor ambient temperature factor	-100.0	100.0	%	0.0		705	
P2.7.10	Motor cooling factor at zero speed	0.0	150.0	%	40.0		706	
P2.7.11	Motor thermal time constant	1	200	min	Varies		707	
P2.7.12	Motor duty cycle	0	150	%	100		708	
P2.7.13	Stall protection	0	3		0		709	0 = No response 1 = Warning 2 = Fault, stop acc. to 2.4.7 3 = Fault, stop by coasting

Table 11: Protections, G2.7

Index	Parameter	Min	Max	Unit	Default	Cust	ID	Description
P2.7.14	Stall current	0.00	2 x IH	A	IH		710	
P2.7.15	Stall time limit	1.00	120.00	s	15.00		711	
P2.7.16	Stall frequency limit	1.0	P2.1.2	Hz	25.00		712	
P2.7.17	Underload protection	0	3		0		713	0 = No response 1 = Warning 2 = Fault, stop acc. to 2.4.7 3 = Fault, stop by coasting
P2.7.18	UP From Torque	10.0	150.0	%	50.0		714	
P2.7.19	UP Zero frequency load	5.0	150.0	%	10.0		715	
P2.7.20	Underload protection time limit	2.00	600.00	s	20.00		716	
P2.7.21	Response to thermistor fault	0	3		2		732	0 = No response 1 = Warning 2 = Fault, stop acc. to 2.4.7 3 = Fault, stop by coasting
P2.7.22	Response to field-bus fault	0	3		2		733	See P2.7.21
P2.7.23	Response to slot fault	0	3		2		734	See P2.7.21

2.4.9 AUTORESTART PARAMETERS (CONTROL KEYPAD: MENU M2 -> G2.8)

Table 12: Autorestart parameters, G2.8

Index	Parameter	Min	Max	Unit	Default	Cust	ID	Description
P2.8.1	Wait time	0.10	10.00	s	0.50		717	
P2.8.2	Trial time	0.00	60.00	s	30.00		718	
P2.8.3	Start function	0	2		0		719	0 = Ramp 1 = Flying start 2 = According to P2.4.6
P2.8.4	Number of tries after undervoltage trip	0	10		0		720	
P2.8.5	Number of tries after overvoltage trip	0	10		0		721	
P2.8.6	Number of tries after overcurrent trip	0	3		0		722	
P2.8.7	Number of tries after 4mA reference trip	0	10		0		723	
P2.8.8	Number of tries after motor temperature fault trip	0	10		0		726	
P2.8.9	Number of tries after external fault trip	0	10		0		725	
P2.8.10	Number of tries after underload fault trip	0	10		0		738	

2.4.10 KEYPAD CONTROL (CONTROL KEYPAD: MENU M3)

The parameters for the selection of control place and direction on the keypad are listed below. See the Keypad control menu in the product's User Manual.

Table 13: Keypad control parameters, M3

Index	Parameter	Min	Max	Unit	Default	Cust	ID	Description
P3.1	Control place	1	3		1		125	1 = I/O terminal 2 = Keypad 3 = Fieldbus
P3.2	Keypad reference	P2.1	P2.2	Hz	0.00			
P3.3	Direction (on keypad)	0	1		0		123	
R3.4	Stop button	0	1		1		114	0 = Limited function of Stop button 1 = Stop button always enabled

2.4.11 SYSTEM MENU (CONTROL KEYPAD: MENU M6)

For parameters and functions related to the general use of the AC drive, such as application and language selection, customised parameter sets or information about the hardware and software, see the product's User Manual.

2.4.12 EXPANDER BOARDS (CONTROL KEYPAD: MENU M7)

The M7 menu shows the expander and option boards attached to the control board and board related information. For more information, see the product's User Manual.

3 LOCAL/REMOTE CONTROL APPLICATION

3.1 INTRODUCTION

Select the Local/Remote Control Application in menu M6 on page S6.2.

With the Local/Remote Control Application it is possible to have two different control places. For each control place the frequency reference can be selected from either the control keypad, I/O terminal or fieldbus. The active control place is selected with the digital input DIN6.

- All outputs are freely programmable.

Additional functions:

- Programmable Start/Stop and Reverse signal logic
- Reference scaling
- One frequency limit supervision
- Second ramps and S-shape ramp programming
- Programmable start and stop functions
- DC-brake at stop
- One prohibit frequency area
- Programmable U/f curve and switching frequency
- Autorestart
- Motor thermal and stall protection: Programmable action; off, warning, fault

The parameters of the Local/Remote Control Application are explained in Chapter 9 *Parameter descriptions* of this manual. The explanations are arranged according to the individual ID number of the parameter.

3.2 CONTROL I/O

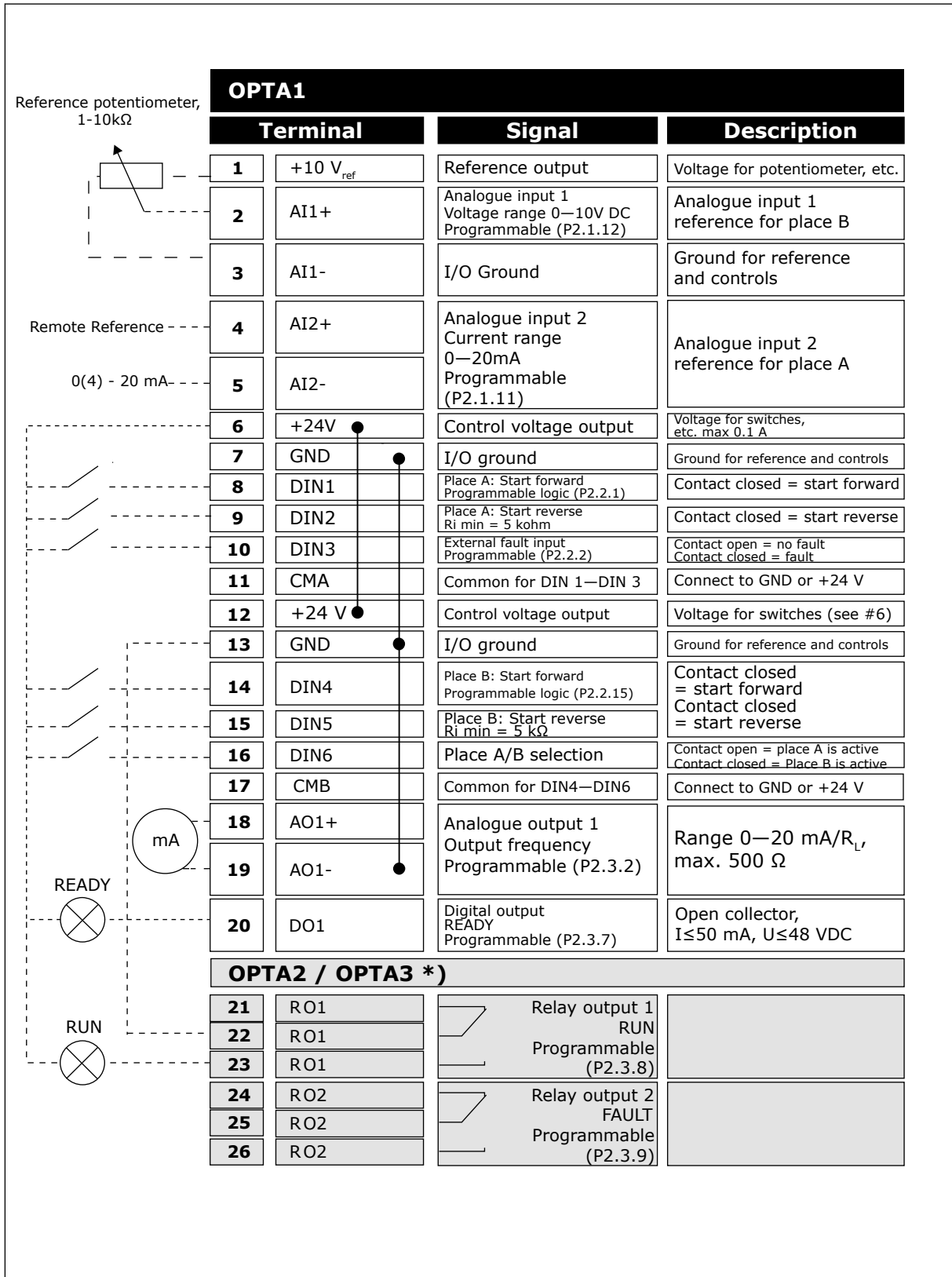

Fig. 7: Local/Remote control application default I/O configuration

*) The option board A3 has no terminal for open contact on its second relay output (terminal 24 is missing).

**NOTE!**

See jumper selections below. More information in the product's User Manual.

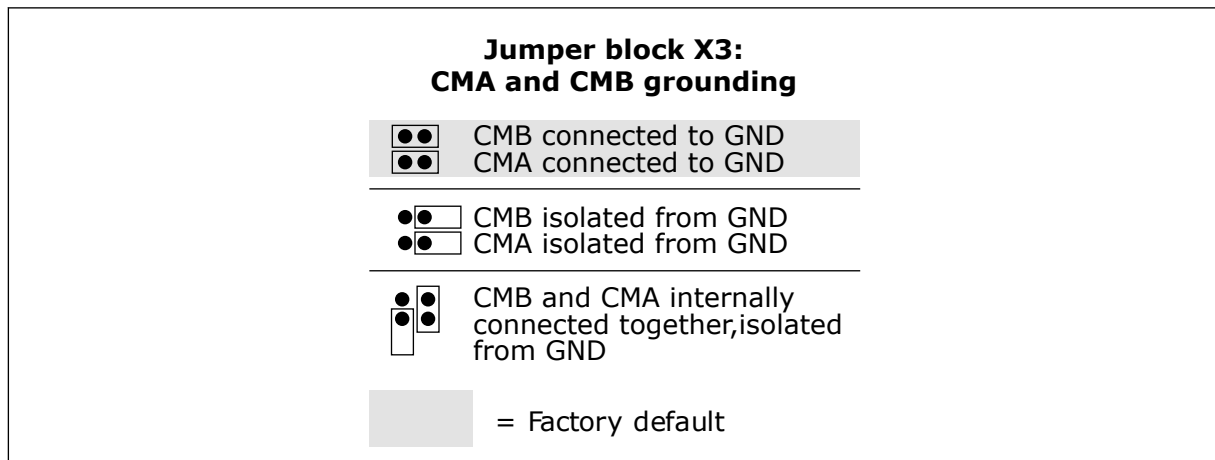

Fig. 8: Jumper selections

3.3 CONTROL SIGNAL LOGIC IN LOCAL/REMOTE APPLICATION

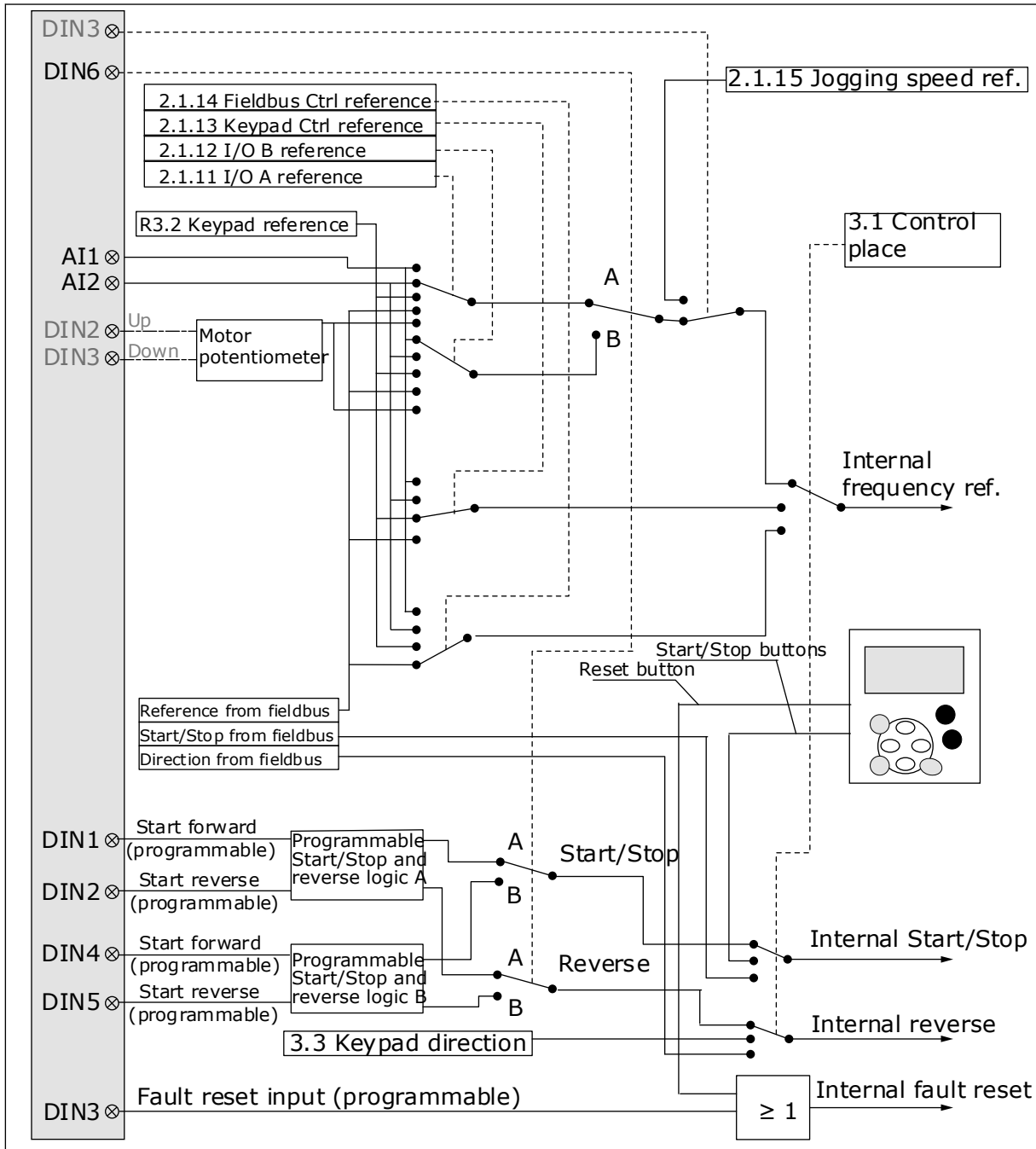

Fig. 9: Control signal logic of the Local/Remote Control Application

3.4 LOCAL/REMOTE CONTROL APPLICATION - PARAMETER LISTS

3.4.1 MONITORING VALUES (CONTROL KEYPAD: MENU M1)

The monitoring values are the actual values of parameters and signals as well as statuses and measurements. Monitoring values cannot be edited.

Table 14: Monitoring values

Index	Monitoring value	Unit	Form	ID	Description
V1.1	Output frequency	Hz	###	1	
V1.2	Frequency reference	Hz	###	25	
V1.3	Motor speed	rpm	#	2	
V1.4	Motor current	A	Varies	3	
V1.5	Motor torque	%	##	4	
V1.6	Motor power	%	##	5	
V1.7	Motor voltage	V	##	6	
V1.8	DC link voltage	V	#	7	
1.9	Unit temperature	°C	#	8	
1.10	Motor temperature	%	##	9	
V1.11	Analogue input 1	V/mA	###	13	
V1.12	Analogue input 2	V/mA	###	14	
V1.13	DIN 1, 2, 3			15	
V1.14	DIN 4, 5, 6			16	
V1.15	D01, R01, R02			17	
V1.16	Analogue lout	mA	###	26	
V1.17	Multimonitoring items				

3.4.2 BASIC PARAMETERS (CONTROL KEYPAD: MENU M2 -> G2.1)

Table 15: Basic parameters G2.1

Index	Parameter	Min	Max	Unit	Default	Cust	ID	Description
P2.1.1	Min frequency	0.00	P2.1.2	Hz	0.00		101	
P2.1.2	Max frequency	P2.1.1	320.00	Hz	50.00		102	
P2.1.3	Acceleration time 1	0.1	3000.0	s	0.0		103	
P2.1.4	Deceleration time 1	0.1	3000.0	s	0.0		104	
P2.1.5	Current limit	0.1 x IH	2 x IH	A	IL		107	
P2.1.6 *	Nominal voltage of the motor	180	690	V	NX2: 230V NX5: 400V NX6: 690V		110	
P2.1.7 *	Nominal frequency of the motor	8.00	320.00	Hz	50.00		111	
P2.1.8 *	Nominal speed of the motor	24	20 000	rpm	1440		112	
P2.1.9 *	Nominal current of the motor	0.1 x IH	2 X IH	A	IH		113	
P2.1.10 *	Motor cos phi	0.30	1.00		0.85		120	
P2.1.11 *	I/O A reference	0	4		1		117	0 = AI1 1 = AI2 2 = Keypad 3 = Fieldbus 4 = Motor potentiometer
P2.1.12 *	I/O B reference	0	4		0		131	0 = AI1 1 = AI2 2 = Keypad 3 = Fieldbus 4 = Motor potentiometer
P2.1.13 *	Keypad control reference	0	3		2		121	0 = AI1 1 = AI2 2 = Keypad 3 = Fieldbus

Table 15: Basic parameters G2.1

Index	Parameter	Min	Max	Unit	Default	Cust	ID	Description
P2.1.14 *	Fieldbus control reference	0	3		3		122	0 = AI1 1 = AI2 2 = Keypad 3 = Fieldbus
P2.1.15 *	Jogging speed reference	0.00	P2.1.2	Hz	0.00		124	

* = Parameter value can only be changed after the AC drive has been stopped.

3.4.3 INPUT SIGNALS (CONTROL KEYPAD: MENU M2 -> G2.2)

Table 16: Input signals, G2.2

Index	Parameter	Min	Max	Unit	Default	Cust	ID	Description
P2.2.1 ***	Place A Start/Stop logic selection	0	8		0		300	<p>Logic = 0 Ctrl sgn 1 = Start forward Ctrl sgn 2 = Start reverse</p> <p>Logic = 1 Ctrl sgn 1 = Start/Stop Ctrl sgn 2 = Reverse</p> <p>Logic = 2 Ctrl sgn 1 = Start/Stop Ctrl sgn 2 = Run enable</p> <p>Logic = 3 Ctrl sgn 1 = Start pulse (edge) Ctrl sgn 2 = Stop pulse</p> <p>Logic = 4 Ctrl sgn 1 = Start forward Ctrl sgn 2 = Motor potentiometer UP</p> <p>Logic = 5 Ctrl sgn 1 = Start forward (edge) Ctrl sgn 2 = Start reverse (edge)</p> <p>Logic = 6 Ctrl sgn 1 = Start (edge) / Stop Ctrl sgn 2 = Reverse</p> <p>Logic = 7 Ctrl sgn 1 = Start (edge) / Stop Ctrl sgn 2 = Run enable</p> <p>Logic = 8 Ctrl sgn 1 = Start forward (edge) Ctrl sgn 2 = Motor potentiometer UP</p>

Table 16: Input signals, G2.2

Index	Parameter	Min	Max	Unit	Default	Cust	ID	Description
P2.2.2	DIN3 function	0	13		1		301	0 = Not used 1 = Ext. fault, closing cont. 2 = Ext. fault, opening cont. 3 = Run enable 4 = Acc./Dec. time select. 5 = Force cp. to I/O 6 = Force cp. to keypad 7 = Force cp. to field-bus 8 = Reverse 9 = Jogging speed 11 = Acc./Dec. operation prohibit 12 = DC Braking command 13 = Motor potentiometer DOWN
P2.2.3 ****	AI1 signal selection	0.1	E.10		A1		377	
P2.2.4	AI1 signal range	0	2		0		320	0 = 0-10V (0-20 mA**) 1 = 2-10V (4-20 mA**) 2 = Custom setting range**
P2.2.5	AI1 custom setting minimum	-160.00	160.00	%	0.00		321	
P2.2.6	AI1 custom setting maximum	-160.00	160.00	%	100.00		322	
P2.2.7	AI1 signal inversion	0	1		0		323	
P2.2.8	AI1 signal filter time	0.00	10.00	s	0.10		324	
P2.2.9 ****	AI2 signal selection	0.1	E.10		A.2		388	
P2.2.10	AI2 signal range	0	2		1		325	0 = 0-10V (0-20 mA**) 1 = 2-10V (4-20 mA**) 2 = Custom setting range**

Table 16: Input signals, G2.2

Index	Parameter	Min	Max	Unit	Default	Cust	ID	Description
P2.2.11	AI2 custom setting minimum	-160.00	160.00	%	0.00		326	
P2.2.12	AI2 custom setting maximum	-160.00	160.00	%	100.00		327	
P2.2.13	AI2 signal inversion	0	1		0		328	
P2.2.14	AI2 signal filter time	0.00	10.00	s	0.10		329	
P2.2.15 ***	Place B Start/Stop logic selection	0	6		0		363	<p>Logic = 0 Ctrl sgn 1 = Start forward Ctrl sgn 2 = Start reverse</p> <p>Logic = 1 Ctrl sgn 1 = Start/Stop Ctrl sgn 2 = Reverse</p> <p>Logic = 2 Ctrl sgn 1 = Start/Stop Ctrl sgn 2 = Run enable</p> <p>Logic = 3 Ctrl sgn 1 = Start pulse (edge) Ctrl sgn 2 = Stop pulse</p> <p>Logic = 4 Ctrl sgn 1 = Forward pulse (edge) Ctrl sgn 2 = Reverse pulse (edge)</p> <p>Logic = 5 Ctrl sgn 1 = Start pulse (edge) Ctrl sgn 2 = Reverse pulse</p> <p>Logic = 6 Ctrl sgn 1 = Start pulse (edge) Ctrl sgn 2 = Enable pulse</p>
P2.2.16	Place A Reference scaling minimum value	0.00	320.00	Hz	0.00		303	
P2.2.17	Place A Reference scaling maximum value	0.00					304	

Table 16: Input signals, G2.2

Index	Parameter	Min	Max	Unit	Default	Cust	ID	Description
P2.2.18	Place B Reference scaling minimum value	0.00	320.00	Hz	0.00		364	
P2.2.19	Place B Reference scaling maximum value	0.00	320.00	Hz	0.00		365	0.00 = No scaling >0 = scaled max. value
P2.2.20	Free analogue input, signal selection	0	2		0		361	0 = Not used 1 = Analogue input 1 2 = Analogue input 2
P2.2.21	Free analogue input, function	0	4		0		362	0 = No reset 1 = Reduces current limit (P2.1.5) 2 = Reduces DC braking current 3 = Reduces accel. and decel. times 4 = Reduces torque super vision limit
P2.2.22	Motor potentiometer ramp time	0.1	2000.0	Hz/s	10.0		331	
P2.2.23	Motor potentiometer frequency reference memory reset	0	2		1		367	0 = No reset 1 = Reset if stopped or powered down 2 = Reset if powered down
P2.2.24	Start pulse memory	0	1		0		498	0 = Run state not copied 1 = Run state copied

** = Remember to place jumpers of block X2 accordingly. See the product's User Manual.

*** = Parameter value can only be changed after the AC drive has been stopped.

**** = Use TTF method to program these parameters.

3.4.4 OUTPUT SIGNALS (CONTROL KEYPAD: MENU M2 -> G2.3)

Table 17: Output signals, G2.3

Index	Parameter	Min	Max	Unit	Default	Cust	ID	Description
P2.3.1	A01 signal selection	0.1	E.10		A11		464	
P2.3.2	Analogue output function	0	8		1		307	0 = Not used (20 mA/10V) 1 = Output freq. (0-fmax) 2 = Freq. reference (0-fmax) 3 = Motor speed (0-Motor nominal speed) 4 = Motor current (0-InMotor) 5 = Motor torque (0-TnMotor) 6 = 7 = Motor voltage (0-UnMotor) Motor power (0-PnMotor) 8 = DC-link volt (0-1000V)
P2.3.3	Analogue output filter time	0.00	10.00	s	1.00		308	0 = No filtering
P2.3.4	Analogue output inversion	0	1		0		309	0 = Not inverted 1 = Inverted
P2.3.5	Analogue output minimum	0	1		0		310	0 = 0 mA (0 V) 1 = 4 mA (2 V)
P2.3.6	Analogue output scale	10	1000	%	100		311	

Table 17: Output signals, G2.3

Index	Parameter	Min	Max	Unit	Default	Cust	ID	Description
P2.3.7	Digital output 1 function	0	22		1		312	0 = Not used 1 = Ready 2 = Run 3 = Fault 4 = Fault inverted 5 = FC overheat warning 6 = Ext. fault or warning 7 = Ref. fault or warning 8 = Warning 9 = Reversed 10 = Jogging spd selected 11 = At speed 12 = Mot. regulator active 13 = OP freq. limit superv. 1 14 = OP freq. limit superv.2 15 = Torque limit superv. 16 = Ref. limit superv. 17 = Ext. brake control 18 = Control place: IO 19 = FC temp. limit superv. 20 = Unrequested rotation direction 21 = Ext. brake control inverted 22 = Thermistor fault/warn.
P2.3.8	RO1 function	0	22		2		313	As parameter 2.3.7
P2.3.9	RO2 function	0	22		3		314	As parameter 2.3.7
P2.3.10	Output frequency limit 1 supervision	0	2		0		315	0 = No limit 1 = Low limit supervision 2 = High limit supervision
P2.3.11	Output frequency limit 1; Supervised value	0.00	320.00	Hz	0.00		316	

Table 17: Output signals, G2.3

Index	Parameter	Min	Max	Unit	Default	Cust	ID	Description
P2.3.12	Output frequency limit 2 supervision	0	2		0		346	0 = No limit 1 = Low limit supervision 2 = High limit supervision
P2.3.13	Output frequency limit 2; Supervision value	0.00	320.00	Hz	0.00		347	
P2.3.14	Torque limit supervision function	0	2		0		348	0 = No 1 = Low limit 2 = High limit
P2.3.15	Torque limit supervision value	-300.0	300.0	%	0.0		349	
P2.3.16	Reference limit supervision function	0	2		0		350	0 = No 1 = Low limit 2 = High limit
P2.3.17	Reference limit supervision value	0.0	100.0	%	0.0		351	
P2.3.18	External brake Off-delay	0.0	100.0	s	0.5		352	
P2.3.19	External brake On-delay	0.0	100.0	s	1.5		353	
P2.3.20	Frequency converter temperature limit supervision	0	2		0		354	0 = No 1 = Low limit 2 = High limit
P2.3.21	Frequency converter temperature limit value	-10	100	°C	40		355	
P2.3.22	Analogue output 2 scaling	0.1	E.10		0.1		471	
P2.3.23	Analogue output 2 function	0	8		4		472	As parameter 2.3.2
P2.3.24	Analogue output 2 filter time	0.00	10.00	s	1.00		473	0 = No filtering
P2.3.25	Analogue output 2 inversion	0	1		0		474	0 = Not inverted 1 = Inverted
P2.3.26	Analogue output 2 minimum	0	1		0		475	0 = 0 mA (0 V) 1 = 4 mA (2 V)

Table 17: Output signals, G2.3

Index	Parameter	Min	Max	Unit	Default	Cust	ID	Description
P.2.3.27	Analogue output 2 scaling	10	1000	%	1.00		476	

3.4.5 DRIVE CONTROL PARAMETERS (CONTROL KEYPAD: MENU M2 -> G2.4)

Table 18: Drive control parameters, G2.4

Index	Parameter	Min	Max	Unit	Default	Cust	ID	Description
P2.4.1	Ramp 1 shape	0.0	10.0	s	0.1		500	0 = Linear 100 = full acc/dec inc/dec times
P2.4.2	Ramp 2 shape	0.0	10.0	s	0.0		501	0 = Linear 100 = full acc/dec inc/dec times
P2.4.3	Acceleration time 2	0.1	3000.0	s	1.0		502	
P2.4.4	Deceleration time 2	0.1	3000.0	s	1.0		503	
P2.4.5	Brake chopper	0	4		0		504	0 = Disabled 1 = Used when running 2 = External brake chopper 3 = Used when stopped/running 4 = used when run- ning (no testing)
P2.4.6	Start function	0	2		0		505	0 = Ramp 1 = Flying start 2 = Conditional fly- ing start
P2.4.7	Stop function	0	3		0		506	0 = Coasting 1 = Ramp 2 = Ramp+Run enable coast 3 = Coast+Run enable ramp
P2.4.8	DC braking cur- rent	0.00	IL	A	0.7 x IH		507	
P2.4.9	DC braking time at stop	0.00	600.00	s	0.00		508	0 = DC brake is off at stop
P2.4.10	Frequency to start DC braking during ramp stop	0.10	10.00	Hz	1.50		515	
P2.4.11	DC braking time at start	0.00	600.00	s	0.00		516	0 = DC brake is off at start
P2.4.12 *	Flux brake	0	1		0		520	0 = Off 0 = On

Table 18: Drive control parameters, G2.4

Index	Parameter	Min	Max	Unit	Default	Cust	ID	Description
P2.4.13	Flux braking current	0.00	IL	A	IH		519	

3.4.6 PROHIBIT FREQUENCY PARAMETERS (CONTROL KEYPAD: MENU M2 -> G2.5)**Table 19: Prohibit frequency parameters, G2.5**

Index	Parameter	Min	Max	Unit	Default	Cust	ID	Description
P2.5.1	Prohibit frequency range 1 low limit	0.00	320.00	Hz	0.00		509	
P2.5.2	Prohibit frequency range 1 high limit	0.00	320.00	Hz	0.00		510	0 = Prohibit range 1 is off
P2.5.3	Prohibit frequency range 2 low limit	0.00	320.00	Hz	0.00		511	
P2.5.4	Prohibit frequency range 2 high limit	0.00	320.00	Hz	0.00		512	0 = Prohibit range 2 is off
P2.5.5	Prohibit frequency range 3 low limit	0.00	320.00	Hz	0.00		513	
P2.5.6	Prohibit frequency range 3 high limit	0.00	320.00	Hz	0.00		514	0 = Prohibit range 3 is off
P2.5.7	Prohibit acc./dec. ramp	0.1	10.0	x	1.0		518	

3.4.7 MOTOR CONTROL PARAMETERS (CONTROL KEYPAD: MENU M2 -> G2.6)

Table 20: Motor control parameters, G2.6

Index	Parameter	Min	Max	Unit	Default	Cust	ID	Description
P2.6.1 *	Motor control mode	0	1/3		0		600	0 = Frequency control 1 = Speed control NXP: 2 = Open loop torque control 3 = Closed loop speed ctrl 4 = Closed loop torque control
P2.6.2 *	U/f optimisation	0	1		0		109	0 = Not used 1 = Automatic torque boost
P2.6.3 *	U/f ratio selection	0	3		0		108	0 = Linear 1 = Squared 2 = Programmable 3 = Linear with flux optim.
P2.6.4 *	Field weakening point	8.00	320.00	Hz	50.00		602	
P2.6.5 *	Voltage at field weakening point	10.00	200.00	%	100.00		603	
P2.6.6 *	U/f curve midpoint frequency	0.00	P2.6.4	Hz	50.00		604	
P2.6.7 *	U/f curve midpoint voltage	0.00	100.00	%	100.00		605	
P2.6.8 *	Output voltage at zero frequency	0.00	40.00	%	Varies		606	
P2.6.9	Switching frequency	1.0	Varies	kHz	Varies		601	
P2.6.10	Overvoltage controller	0	2		1		607	0 = Not used 1 = Used (no ramping) 2 = Used (ramping)
P2.6.11	Undervoltage controller	0	1		1		608	0 = Not used 1 = Used 2 = Used (ramping to zero)
P2.6.12	Load drooping	0.00	100.00	%	0.00		620	

Table 20: Motor control parameters, G2.6

Index	Parameter	Min	Max	Unit	Default	Cust	ID	Description
P2.6.13	Identification	0	1/2		0		631	0 = No action 1 = Identification w/o run 2 = Identification with run 3 = Encoder ID run 4 = No action 5 = ID Run Failed
Closed Loop parameter group 2.6.14								
P2.6.14.1	Magnetizing current	0.00	2 x IH	A	0.00		612	
P2.6.14.2	Speed control P gain	1	1000		30		613	
P2.6.14.3	Speed control I time	0.0	3200.0	ms	30.0		614	
P2.6.14.5	Acceleration compensation	0.00	300.00	s	0.00		626	
P2.6.14.6	Slip adjust	0	500	%	100		619	
P2.6.14.7	Magnetizing current at start	0,00	IL	A	0.00		627	
P2.6.14.8	Magnetizing time at start	0	60000	ms	0		628	
P2.6.14.9	0-speed time at start	0	32000	ms	100		615	
P2.6.14.10	0-speed time at stop	0	32000	ms	100		616	
P2.6.14.11	Start-up torque	0	3		0		621	0 = Not used 1 = Torque memory 2 = Torque reference 3 = Start-up torque fwd/rev
P2.6.14.12	Start-up torque FWD	-300.0	300.0	%	0.0		633	
P2.6.14.13	Start-up torque REV	-300.0	300.0	%	0.0		634	
P2.6.14.15	Encoder filter time	0.0	100.0	ms	0.0		618	

Table 20: Motor control parameters, G2.6

Index	Parameter	Min	Max	Unit	Default	Cust	ID	Description
P2.6.14.17	Current control P gain	0.00	100.00	%	40.00		617	
Identification parameter group 2.6.15								
P2.6.15.1	Speed step	-50.0	50.0	0.0	0.0		1252	

* = Parameter value can only be changed after the AC drive has been stopped.

3.4.8 PROTECTIONS (CONTROL KEYPAD: MENU M2 -> G2.7)

Table 21: Protections, G2.7

Index	Parameter	Min	Max	Unit	Default	Cust	ID	Description
P2.7.1	Response to 4 mA reference fault	0	5		0		700	0 = No response 1 = Warning 2 = Warning+Previous Freq. 3 = Wrng+Preset-Freq 2.7.2 4 = Fault, stop acc. to 2.4.7 5 = Fault, stop by coasting
P2.7.2	4 mA reference fault frequency	0.00	P2.1.2	Hz	0.00		728	
P2.7.3	Response to external fault	0	3		2		701	0 = No response 1 = Warning 2 = Fault, stop acc. to 2.4.7
P2.7.4	Input phase supervision	0	3		0		730	3 = Fault, stop by coasting
P2.7.5	Response to undervoltage fault	0	1		0		727	0 = Fault stored in history Fault not stored
P2.7.6	Output phase supervision	0	3		2		702	0 = No response 1 = Warning 2 = Fault, stop acc. to 2.4.7
P2.7.7	Earth fault protection	0	3		2		703	3 = Fault, stop by coasting
P2.7.8	Thermal protection of the motor	0	3		2		704	
P2.7.9	Motor ambient temperature factor	-100.0	100.0	%	0.0		705	
P2.7.10	Motor cooling factor at zero speed	0.0	150.0	%	40.0		706	
P2.7.11	Motor thermal time constant	1	200	min	Varies		707	
P2.7.12	Motor duty cycle	0	150	%	100		708	
P2.7.13	Stall protection	0	3		0		709	0 = No response 1 = Warning 2 = Fault, stop acc. to 2.4.7 3 = Fault, stop by coasting

Table 21: Protections, G2.7

Index	Parameter	Min	Max	Unit	Default	Cust	ID	Description
P2.7.14	Stall current	0.00	2 x IH	A	IH		710	
P2.7.15	Stall time limit	1.00	120.00	s	15.00		711	
P2.7.16	Stall frequency limit	1.0	P2.1.2	Hz	25.00		712	
P2.7.17	Underload protection	0	3		0		713	0 = No response 1 = Warning 2 = Fault, stop acc. to 2.4.7 3 = Fault, stop by coasting
P2.7.18	UP From Torque	10.0	150.0	%	50.0		714	
P2.7.19	UP Zero frequency load	5.0	150.0	%	10.0		715	
P2.7.20	Underload protection time limit	2.00	600.00	s	20.00		716	
P2.7.21	Response to thermistor fault	0	3		2		732	0 = No response 1 = Warning 2 = Fault, stop acc. to 2.4.7 3 = Fault, stop by coasting
P2.7.22	Response to field-bus fault	0	3		2		733	See P2.7.21
P2.7.23	Response to slot fault	0	3		2		734	See P2.7.21

3.4.9 AUTORESTART PARAMETERS (CONTROL KEYPAD: MENU M2 -> G2.8)

Table 22: Autorestart parameters, G2.8

Index	Parameter	Min	Max	Unit	Default	Cust	ID	Description
P2.8.1	Wait time	0.10	10.00	s	0.50		717	
P2.8.2	Trial time	0.00	60.00	s	30.00		718	
P2.8.3	Start function	0	2		0		719	0 = Ramp 1 = Flying start 2 = According to P2.4.6
P2.8.4	Number of tries after undervoltage trip	0	10		0		720	
P2.8.5	Number of tries after overvoltage trip	0	10		0		721	
P2.8.6	Number of tries after overcurrent trip	0	3		0		722	
P2.8.7	Number of tries after 4mA reference trip	0	10		0		723	
P2.8.8	Number of tries after motor temperature fault trip	0	10		0		726	
P2.8.9	Number of tries after external fault trip	0	10		0		725	
P2.8.10	Number of tries after underload fault trip	0	10		0		738	

3.4.10 KEYPAD CONTROL (CONTROL KEYPAD: MENU M3)

The parameters for the selection of control place and direction on the keypad are listed below. See the Keypad control menu in the product's User Manual.

Table 23: Keypad control parameters, M3

Index	Parameter	Min	Max	Unit	Default	Cust	ID	Description
P3.1	Control place	1	3		1		125	1 = I/O terminal 2 = Keypad 3 = Fieldbus
P3.2	Keypad reference	P2.1	P2.2	Hz	0.00			
P3.3	Direction (on keypad)	0	1		0		123	
R3.4	Stop button	0	1		1		114	0 = Limited function of Stop button 1 = Stop button always enabled

3.4.11 SYSTEM MENU (CONTROL KEYPAD: MENU M6)

For parameters and functions related to the general use of the AC drive, such as application and language selection, customised parameter sets or information about the hardware and software, see the product's User Manual.

3.4.12 EXPANDER BOARDS (CONTROL KEYPAD: MENU M7)

The M7 menu shows the expander and option boards attached to the control board and board related information. For more information, see the product's User Manual.

4 MULTI-STEP SPEED CONTROL APPLICATION

4.1 INTRODUCTION

Select the Multi-step Speed Control Application in menu M6 on page S6.2.

The Multi-step Speed Control Application can be used in applications where fixed speeds are needed. In total, 15 + 2 different speeds can be programmed: one basic speed, 15 multi-step speeds and one jogging speed. The speed steps are selected with digital signals DIN3, DIN4, DIN5 and DIN6. If jogging speed is used, DIN3 can be programmed from fault reset to jogging speed select.

The basic speed reference can be either voltage or current signal via analogue input terminals (2/ 3 or 4/5). The other one of the analogue inputs can be programmed for other purposes.

- All outputs are freely programmable.

Additional functions:

- Programmable Start/Stop and Reverse signal logic
- Reference scaling
- One frequency limit supervision
- Second ramps and S-shape ramp programming
- Programmable start and stop functions
- DC-brake at stop
- One prohibit frequency area
- Programmable U/f curve and switching frequency
- Autorestart
- Motor thermal and stall protection: Programmable action; off, warning, fault

The parameters of the Multi-Step Speed Control Application are explained in Chapter 9 *Parameter descriptions* of this manual. The explanations are arranged according to the individual ID number of the parameter.

4.2 CONTROL I/O

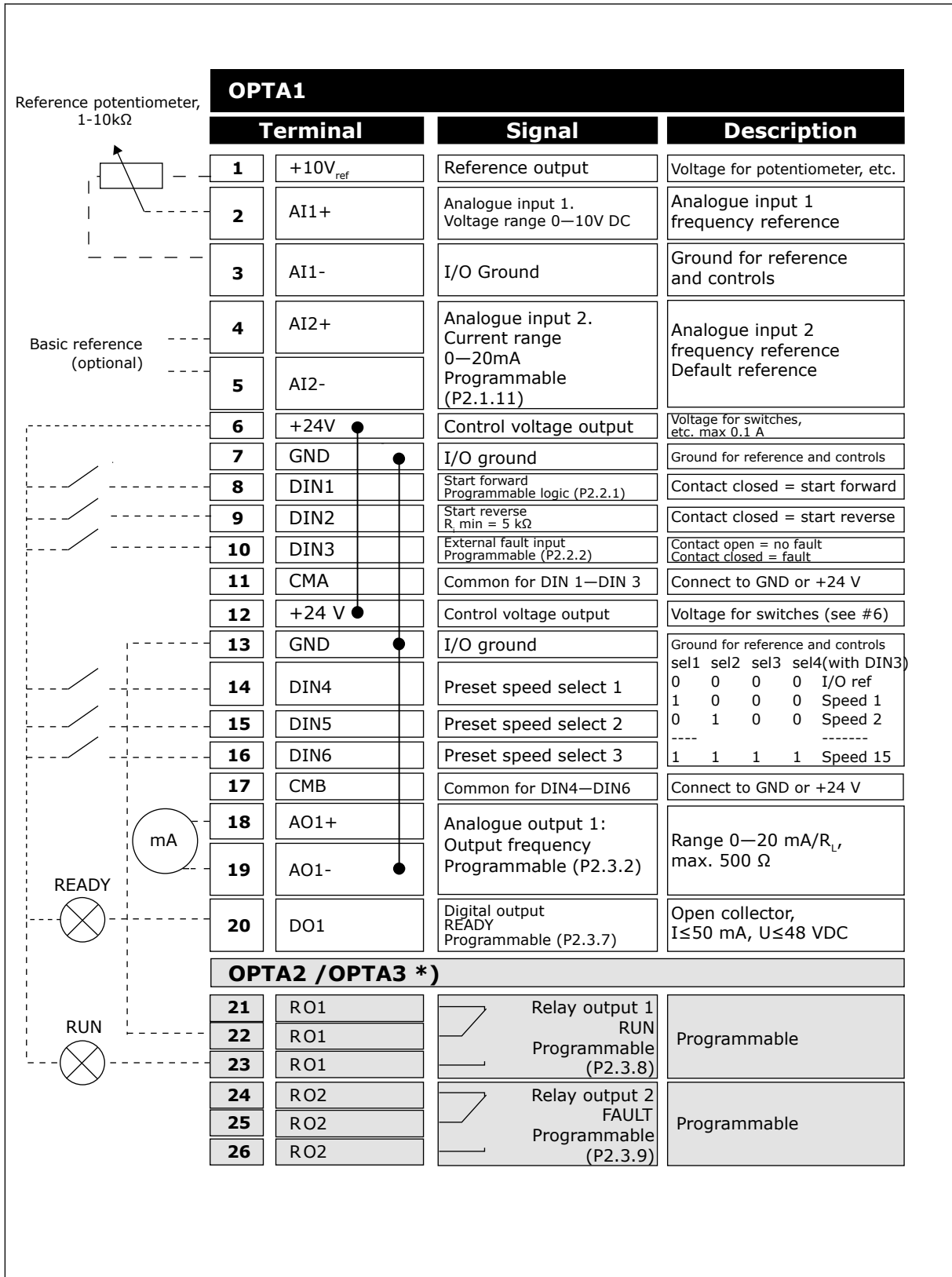

Fig. 10: Multi-step speed control application default I/O configuration

*) The option board A3 has no terminal for open contact on its second relay output (terminal 24 is missing).



NOTE!

See jumper selections below. More information in the product's User Manual.

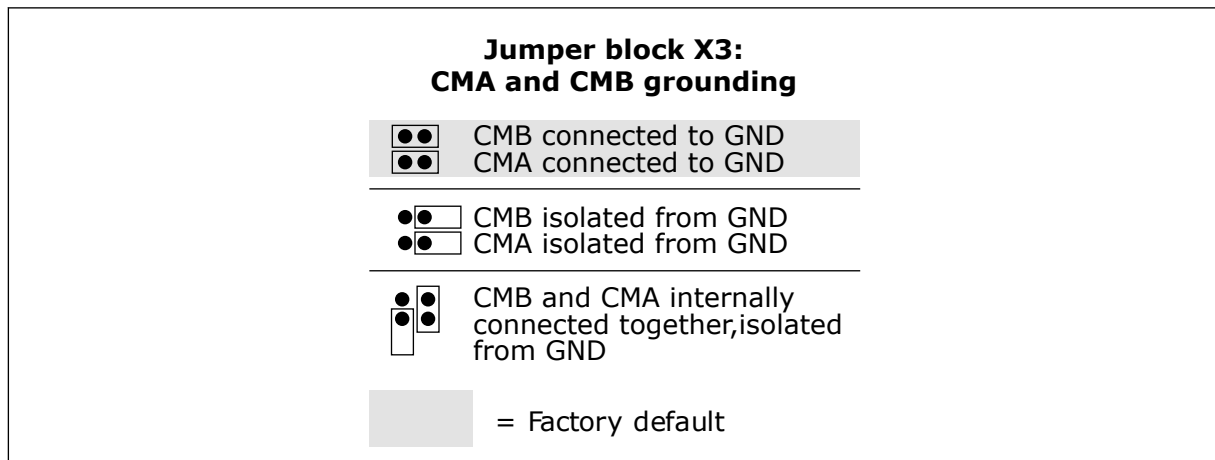

Fig. 11: Jumper selections

4.3 CONTROL SIGNAL LOGIC IN MULTI-STEP SPEED CONTROL APPLICATION

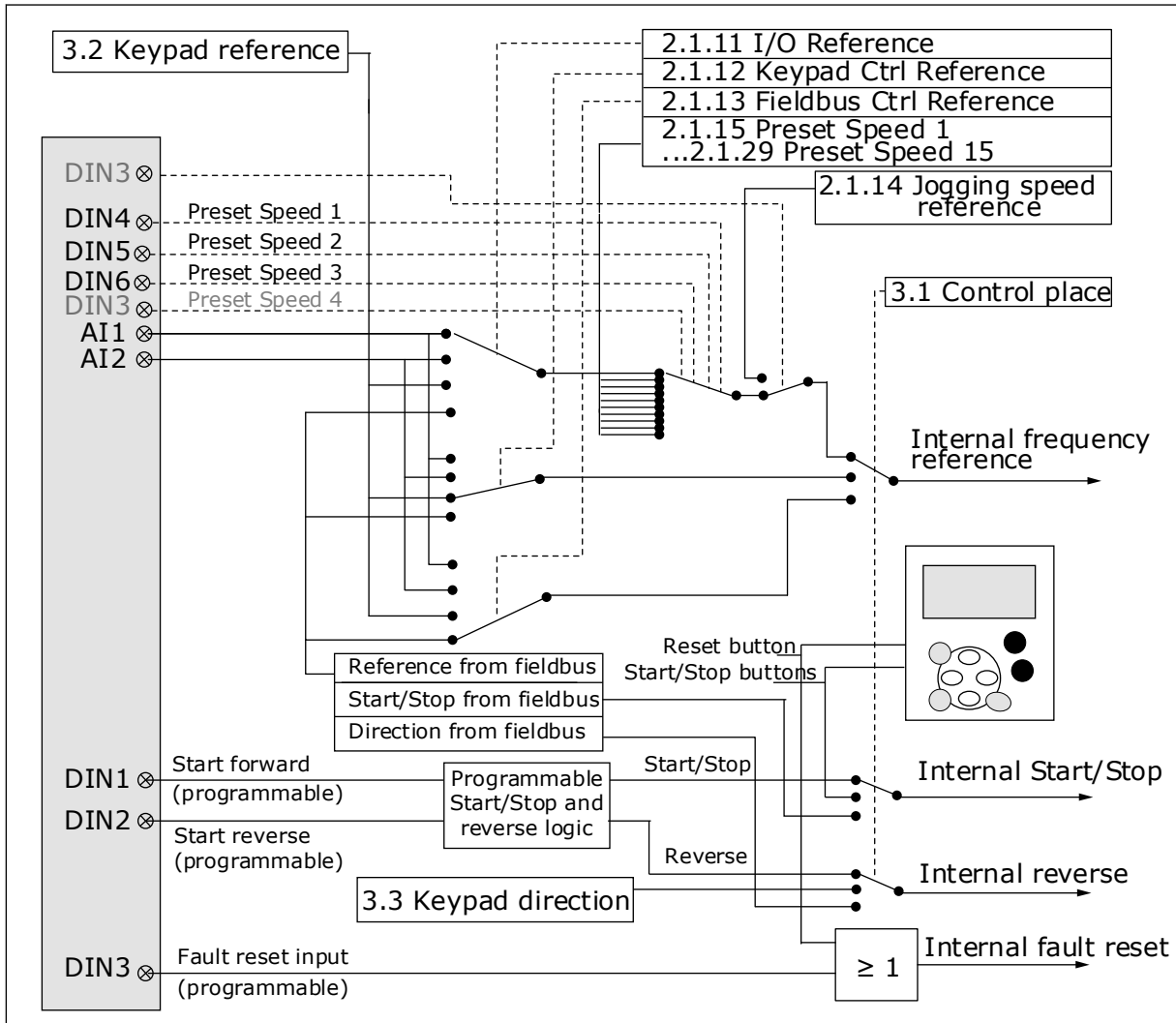

Fig. 12: Control signal logic of the Multi-step Speed Application

4.4 MULTI-STEP SPEED CONTROL APPLICATION - PARAMETER LISTS

4.4.1 MONITORING VALUES (CONTROL KEYPAD: MENU M1)

The monitoring values are the actual values of parameters and signals as well as statuses and measurements. Monitoring values cannot be edited.

Table 24: Monitoring values

Index	Monitoring value	Unit	Form	ID	Description
V1.1	Output frequency	Hz	###	1	
V1.2	Frequency reference	Hz	###	25	
V1.3	Motor speed	rpm	#	2	
V1.4	Motor current	A	Varies	3	
V1.5	Motor torque	%	##	4	
V1.6	Motor power	%	##	5	
V1.7	Motor voltage	V	##	6	
V1.8	DC link voltage	V	#	7	
1.9	Unit temperature	°C	#	8	
1.10	Motor temperature	%	##	9	
V1.11	Analogue input 1	V/mA	###	13	
V1.12	Analogue input 2	V/mA	###	14	
V1.13	DIN 1, 2, 3			15	
V1.14	DIN 4, 5, 6			16	
V1.15	D01, R01, R02			17	
V1.16	Analogue lout	mA	###	26	
V1.17	Multimonitoring items				

4.4.2 BASIC PARAMETERS (CONTROL KEYPAD: MENU M2 -> G2.1)

Table 25: Basic parameters G2.1

Index	Parameter	Min	Max	Unit	Default	Cust	ID	Description
P2.1.1	Min frequency	0.00	P2.1.2	Hz	0.00		101	
P2.1.2	Max frequency	P2.1.1	320.00	Hz	50.00		102	
P2.1.3	Acceleration time 1	0.1	3000.0	s	0.0		103	
P2.1.4	Deceleration time 1	0.1	3000.0	s	0.0		104	
P2.1.5	Current limit	0.1 x IH	2 x IH	A	IL		107	
P2.1.6 *	Nominal voltage of the motor	180	690	V	NX2: 230V NX5: 400V NX6: 690V		110	
P2.1.7 *	Nominal frequency of the motor	8.00	320.00	Hz	50.00		111	
P2.1.8 *	Nominal speed of the motor	24	20 000	rpm	1440		112	
P2.1.9 *	Nominal current of the motor	0.1 x IH	2 X IH	A	IH		113	
P2.1.10 *	Motor cos phi	0.30	1.00		0.85		120	
P2.1.11 *	I/O reference	0	3		1		117	0 = AI1 1 = AI2 2 = Keypad 3 = Fieldbus
P2.1.12 *	Keypad control reference	0	3		2		121	0 = AI1 1 = AI2 2 = Keypad 3 = Fieldbus
P2.1.13 *	Fieldbus control reference	0	3		3		122	0 = AI1 1 = AI2 2 = Keypad 3 = Fieldbus
P2.1.14	Jogging speed ref.	0.00	P2.1.2	Hz	0.00		124	
P2.1.15	Preset speed 1	0.00	P2.1.2	Hz	5.00		105	
P2.1.16	Preset speed 2	0.00	P2.1.2	Hz	10.00		106	

Table 25: Basic parameters G2.1

Index	Parameter	Min	Max	Unit	Default	Cust	ID	Description
P2.1.17	Preset speed 3	0.00	P2.1.2	Hz	12.50		126	
P2.1.18	Preset speed 4	0.00	P2.1.2	Hz	15.00		127	
P2.1.19	Preset speed 5	0.00	P2.1.2	Hz	17.50		128	
P2.1.20	Preset speed 6	0.00	P2.1.2	Hz	20.00		129	
P2.1.21	Preset speed 7	0.00	P2.1.2	Hz	22.50		130	
P2.1.22	Preset speed 8	0.00	P2.1.2	Hz	25.00		133	
P2.1.23	Preset speed 9	0.00	P2.1.2	Hz	27.50		134	
P2.1.24	Preset speed 10	0.00	P2.1.2	Hz	30.00		135	
P2.1.25	Preset speed 11	0.00	P2.1.2	Hz	32.50		136	
P2.1.26	Preset speed 12	0.00	P2.1.2	Hz	35.00		137	
P2.1.27	Preset speed 13	0.00	P2.1.2	Hz	40.00		138	
P2.1.28	Preset speed 14	0.00	P2.1.2	Hz	45.00		139	
P2.1.29	Preset speed 15	0.00	P2.1.2	Hz	50.00		140	

* = Parameter value can only be changed after the AC drive has been stopped.

4.4.3 INPUT SIGNALS (CONTROL KEYPAD: MENU M2 -> G2.2)

Table 26: Input signals, G2.2

Index	Parameter	Min	Max	Unit	Default	Cust	ID	Description
P2.2.1 ***	Start/Stop logic	0	6		0		300	<p>Logic = 0 Ctrl sgn 1 = Start forward Ctrl sgn 2 = Start reverse</p> <p>Logic = 1 Ctrl sgn 1 = Start/Stop Ctrl sgn 2 = Reverse</p> <p>Logic = 2 Ctrl sgn 1 = Start/Stop Ctrl sgn 2 = Run enable</p> <p>Logic = 3 Ctrl sgn 1 = Start pulse (edge) Ctrl sgn 2 = Stop pulse</p> <p>Logic = 4 Ctrl sgn 1 = Forward pulse (edge) Ctrl sgn 2 = Reverse pulse (edge)</p> <p>Logic = 5 Ctrl sgn 1 = Start pulse (edge) Ctrl sgn 2 = Reverse pulse</p> <p>Logic = 6 Ctrl sgn 1 = Start pulse (edge) Ctrl sgn 2 = Enable pulse</p>

Table 26: Input signals, G2.2

Index	Parameter	Min	Max	Unit	Default	Cust	ID	Description
P2.2.2	DIN3 function	0	13		1		301	0 = Not used 1 = Ext. fault, closing cont. 2 = Ext. fault, opening cont. 3 = Run enable 4 = Acc./Dec. time select. 5 = Force cp. to I/O 6 = Force cp. to keypad 7 = Force cp. to field-bus 8 = Rvs (if P2.2.1 ≠ 2,3 or 6) 9 = Jogging speed 10 = Fault reset 11 = Acc./Dec. operation prohibit 12 = DC Braking command 13 = Preset speed
P2.2.3 ****	AI1 signal selection	0.1	E.10		A1		377	
P2.2.4	AI1 signal range	0	2		0		320	0 = 0-10V (0-20 mA**) 1 = 2-10V (4-20 mA**) 2 = Custom setting range**
P2.2.5	AI1 custom setting minimum	-160.00	160.00	%	0.00		321	
P2.2.6	AI1 custom setting maximum	-160.00	160.00	%	100.00		322	
P2.2.7	AI1 signal inversion	0	1		0		323	
P2.2.8	AI1 signal filter time	0.00	10.00	s	0.10		324	
P2.2.9 ****	AI2 signal selection	0.1	E.10		A.2		388	
P2.2.10	AI2 signal range	0	2		1		325	0 = 0-10V (0-20 mA**) 1 = 2-10V (4-20 mA**) 2 = Custom setting range**

Table 26: Input signals, G2.2

Index	Parameter	Min	Max	Unit	Default	Cust	ID	Description
P2.2.11	AI2 custom setting minimum	-160.00	160.00	%	0.00		326	
P2.2.12	AI2 custom setting maximum	-160.00	160.00	%	100.00		327	
P2.2.13	AI2 signal inversion	0	1		0		328	
P2.2.14	AI2 signal filter time	0.00	10.00	s	0.10		329	
P2.2.15	Reference scaling minimum value	0.00	320.00	Hz	0.00		303	
P2.2.16	Reference scaling maximum value	0.00	320.00	Hz	0.00		304	0.00 = No scaling >0 = scaled max. value
P2.2.17	Free analogue input, signal selection	0	2		0		361	0 = Not used 1 = AI1 2 = AI2
P2.2.18	Free analogue input, function	0	4		0		362	0 = No function 1 = Reduces current limit (P2.1.5) 2 = Reduces DC braking current, P2.4.8 3 = Reduces accel. and decel. times 4 = Reduces torque supervision limit P2.3.15

CP = control place

cc = closing contact

oc = opening contact

** = Remember to place jumpers of block X2 accordingly. See the product's User Manual.

*** = Parameter value can only be changed after the AC drive has been stopped.

**** = Use TTF method to program these parameters.

4.4.4 OUTPUT SIGNALS (CONTROL KEYPAD: MENU M2 -> G2.3)

Table 27: Output signals, G2.3

Index	Parameter	Min	Max	Unit	Default	Cust	ID	Description
P2.3.1 *	A01 signal selection	0.1	E.10		A11		464	
P2.3.2	Analogue output function	0	8		1		307	0 = Not used (20 mA/10V) 1 = Output freq. (0-fmax) 2 = Freq. reference (0-fmax) 3 = Motor speed (0-Motor nominal speed) 4 = Motor current (0-InMotor) 5 = Motor torque (0-TnMotor) 6 = Motor power (0-PnMotor) 7 = Motor voltage (0-UnMotor) 8 = DC-link volt (0-1000V)
P2.3.3	Analogue output filter time	0.00	10.00	s	1.00		308	0 = No filtering
P2.3.4	Analogue output inversion	0	1		0		309	0 = Not inverted 1 = Inverted
P2.3.5	Analogue output minimum	0	1		0		310	0 = 0 mA (0 V) 1 = 4 mA (2 V)
P2.3.6	Analogue output scale	10	1000	%	100		311	

Table 27: Output signals, G2.3

Index	Parameter	Min	Max	Unit	Default	Cust	ID	Description
P2.3.7	Digital output 1 function	0	22		1		312	0 = Not used 1 = Ready 2 = Run 3 = Fault 4 = Fault inverted 5 = FC overheat warning 6 = Ext. fault or warning 7 = Ref. fault or warning 8 = Warning 9 = Reversed 10 = Jogging spd selected 11 = At speed 12 = Mot. regulator active 13 = OP freq. limit superv. 1 14 = OP freq. limit superv.2 15 = Torque limit superv. 16 = Ref. limit superv. 17 = Ext. brake control 18 = Control place: IO 19 = FC temp. limit superv. 20 = Unrequested rotation direction 21 = Ext. brake control inverted 22 = Thermistor fault/warn.
P2.3.8	RO1 function	0	22		2		313	As parameter 2.3.7
P2.3.9	RO2 function	0	22		3		314	As parameter 2.3.7
P2.3.10	Output frequency limit 1 supervision	0	2		0		315	0 = No limit 1 = Low limit supervision 2 = High limit supervision
P2.3.11	Output frequency limit 1; Supervised value	0.00	320.00	Hz	0.00		316	

Table 27: Output signals, G2.3

Index	Parameter	Min	Max	Unit	Default	Cust	ID	Description
P2.3.12	Output frequency limit 2 supervision	0	2		0		346	0 = No limit 1 = Low limit supervision 2 = High limit supervision
P2.3.13	Output frequency limit 2; Supervision value	0.00	320.00	Hz	0.00		347	
P2.3.14	Torque limit supervision function	0	2		0		348	0 = No 1 = Low limit 2 = High limit
P2.3.15	Torque limit supervision value	-300.0	300.0	%	0.0		349	
P2.3.16	Reference limit supervision function	0	2		0		350	0 = No 1 = Low limit 2 = High limit
P2.3.17	Reference limit supervision value	0.0	100.0	%	0.0		351	
P2.3.18	External brake Off-delay	0.0	100.0	s	0.5		352	
P2.3.19	External brake On-delay	0.0	100.0	s	1.5		353	
P2.3.20	Frequency converter temperature limit supervision	0	2		0		354	0 = No 1 = Low limit 2 = High limit
P2.3.21	Frequency converter temperature limit value	-10	100	°C	40		355	
P2.3.22 *	Analogue output 2 scaling	0.1	E.10		0.1		471	
P2.3.23 *	Analogue output 2 function	0	8		4		472	As parameter 2.3.2
P2.3.24 *	Analogue output 2 filter time	0.00	10.00	s	1.00		473	0 = No filtering
P2.3.25 *	Analogue output 2 inversion	0	1		0		474	0 = Not inverted 1 = Inverted
P2.3.26 *	Analogue output 2 minimum	0	1		0		475	0 = 0 mA (0 V) 1 = 4 mA (2 V)

Table 27: Output signals, G2.3

Index	Parameter	Min	Max	Unit	Default	Cust	ID	Description
P.2.3.27 *	Analogue output 2 scaling	10	1000	%	1.00		476	

* = Use TTF method to program these parameters

4.4.5 DRIVE CONTROL PARAMETERS (CONTROL KEYPAD: MENU M2 -> G2.4)

Table 28: Drive control parameters, G2.4

Index	Parameter	Min	Max	Unit	Default	Cust	ID	Description
P2.4.1	Ramp 1 shape	0.0	10.0	s	0.1		500	0 = Linear 100 = full acc/dec inc/dec times
P2.4.2	Ramp 2 shape	0.0	10.0	s	0.0		501	0 = Linear 100 = full acc/dec inc/dec times
P2.4.3	Acceleration time 2	0.1	3000.0	s	1.0		502	
P2.4.4	Deceleration time 2	0.1	3000.0	s	1.0		503	
P2.4.5	Brake chopper	0	4		0		504	0 = Disabled 1 = Used when running 2 = External brake chopper 3 = Used when stopped/running 4 = used when run- ning (no testing)
P2.4.6	Start function	0	2		0		505	0 = Ramp 1 = Flying start 2 = Conditional fly- ing start
P2.4.7	Stop function	0	3		0		506	0 = Coasting 1 = Ramp 2 = Ramp+Run enable coast 3 = Coast+Run enable ramp
P2.4.8	DC braking cur- rent	0.00	IL	A	0.7 x IH		507	
P2.4.9	DC braking time at stop	0.00	600.00	s	0.00		508	0 = DC brake is off at stop
P2.4.10	Frequency to start DC braking during ramp stop	0.10	10.00	Hz	1.50		515	
P2.4.11	DC braking time at start	0.00	600.00	s	0.00		516	0 = DC brake is off at start
P2.4.12 *	Flux brake	0	1		0		520	0 = Off 0 = On

Table 28: Drive control parameters, G2.4

Index	Parameter	Min	Max	Unit	Default	Cust	ID	Description
P2.4.13	Flux braking current	0.00	IL	A	IH		519	

4.4.6 PROHIBIT FREQUENCY PARAMETERS (CONTROL KEYPAD: MENU M2 -> G2.5)

Table 29: Prohibit frequency parameters, G2.5

Index	Parameter	Min	Max	Unit	Default	Cust	ID	Description
P2.5.1	Prohibit frequency range 1 low limit	0.00	320.00	Hz	0.00		509	
P2.5.2	Prohibit frequency range 1 high limit	0.00	320.00	Hz	0.00		510	0 = Prohibit range 1 is off
P2.5.3	Prohibit frequency range 2 low limit	0.00	320.00	Hz	0.00		511	
P2.5.4	Prohibit frequency range 2 high limit	0.00	320.00	Hz	0.00		512	0 = Prohibit range 2 is off
P2.5.5	Prohibit frequency range 3 low limit	0.00	320.00	Hz	0.00		513	
P2.5.6	Prohibit frequency range 3 high limit	0.00	320.00	Hz	0.00		514	0 = Prohibit range 3 is off
P2.5.7	Prohibit acc./dec. ramp	0.1	10.0	x	1.0		518	

4.4.7 MOTOR CONTROL PARAMETERS (CONTROL KEYPAD: MENU M2 -> G2.6)

Table 30: Motor control parameters, G2.6

Index	Parameter	Min	Max	Unit	Default	Cust	ID	Description
P2.6.1 *	Motor control mode	0	1/3		0		600	0 = Frequency control 1 = Speed control NXP: 2 = Open loop torque control 3 = Closed loop speed ctrl 4 = Closed loop torque control
P2.6.2 *	U/f optimisation	0	1		0		109	0 = Not used 1 = Automatic torque boost
P2.6.3 *	U/f ratio selection	0	3		0		108	0 = Linear 1 = Squared 2 = Programmable 3 = Linear with flux optim.
P2.6.4 *	Field weakening point	8.00	320.00	Hz	50.00		602	
P2.6.5 *	Voltage at field weakening point	10.00	200.00	%	100.00		603	
P2.6.6 *	U/f curve midpoint frequency	0.00	P2.6.4	Hz	50.00		604	
P2.6.7 *	U/f curve midpoint voltage	0.00	100.00	%	100.00		605	
P2.6.8 *	Output voltage at zero frequency	0.00	40.00	%	Varies		606	
P2.6.9	Switching frequency	1.0	Varies	kHz	Varies		601	
P2.6.10	Overvoltage controller	0	2		1		607	0 = Not used 1 = Used (no ramping) 2 = Used (ramping)
P2.6.11	Undervoltage controller	0	1		1		608	0 = Not used 1 = Used 2 = Used (ramping to zero)
P2.6.12	Load drooping	0.00	100.00	%	0.00		620	

Table 30: Motor control parameters, G2.6

Index	Parameter	Min	Max	Unit	Default	Cust	ID	Description
P2.6.13	Identification	0	1/2		0		631	0 = No action 1 = Identification w/o run 2 = Identification with run 3 = Encoder ID run 4 = No action 5 = ID Run Failed
Closed Loop parameter group 2.6.14								
P2.6.14.1	Magnetizing current	0.00	2 x IH	A	0.00		612	
P2.6.14.2	Speed control P gain	1	1000		30		613	
P2.6.14.3	Speed control I time	0.0	3200.0	ms	30.0		614	
P2.6.14.5	Acceleration compensation	0.00	300.00	s	0.00		626	
P2.6.14.6	Slip adjust	0	500	%	100		619	
P2.6.14.7	Magnetizing current at start	0,00	IL	A	0.00		627	
P2.6.14.8	Magnetizing time at start	0	60000	ms	0		628	
P2.6.14.9	0-speed time at start	0	32000	ms	100		615	
P2.6.14.10	0-speed time at stop	0	32000	ms	100		616	
P2.6.14.11	Start-up torque	0	3		0		621	0 = Not used 1 = Torque memory 2 = Torque reference 3 = Start-up torque fwd/rev
P2.6.14.12	Start-up torque FWD	-300.0	300.0	%	0.0		633	
P2.6.14.13	Start-up torque REV	-300.0	300.0	%	0.0		634	
P2.6.14.15	Encoder filter time	0.0	100.0	ms	0.0		618	

Table 30: Motor control parameters, G2.6

Index	Parameter	Min	Max	Unit	Default	Cust	ID	Description
P2.6.14.17	Current control P gain	0.00	100.00	%	40.00		617	
Identification parameter group 2.6.15								
P2.6.15.1	Speed step	-50.0	50.0	0.0	0.0		1252	

* = Parameter value can only be changed after the AC drive has been stopped.

4.4.8 PROTECTIONS (CONTROL KEYPAD: MENU M2 -> G2.7)

Table 31: Protections, G2.7

Index	Parameter	Min	Max	Unit	Default	Cust	ID	Description
P2.7.1	Response to 4 mA reference fault	0	5		0		700	0 = No response 1 = Warning 2 = Warning+Previous Freq. 3 = Wrng+Preset-Freq 2.7.2 4 = Fault, stop acc. to 2.4.7 5 = Fault, stop by coasting
P2.7.2	4 mA reference fault frequency	0.00	P2.1.2	Hz	0.00		728	
P2.7.3	Response to external fault	0	3		2		701	0 = No response 1 = Warning 2 = Fault, stop acc. to 2.4.7 3 = Fault, stop by coasting
P2.7.4	Input phase supervision	0	3		3		730	
P2.7.5	Response to undervoltage fault	0	1		0		727	0 = Fault stored in history Fault not stored
P2.7.6	Output phase supervision	0	3		2		702	0 = No response 1 = Warning 2 = Fault, stop acc. to 2.4.7 3 = Fault, stop by coasting
P2.7.7	Earth fault protection	0	3		2		703	
P2.7.8	Thermal protection of the motor	0	3		2		704	
P2.7.9	Motor ambient temperature factor	-100.0	100.0	%	0.0		705	
P2.7.10	Motor cooling factor at zero speed	0.0	150.0	%	40.0		706	
P2.7.11	Motor thermal time constant	1	200	min	Varies		707	
P2.7.12	Motor duty cycle	0	150	%	100		708	

Table 31: Protections, G2.7

Index	Parameter	Min	Max	Unit	Default	Cust	ID	Description
P2.7.13	Stall protection	0	3		0		709	0 = No response 1 = Warning 2 = Fault, stop acc. to 2.4.7 3 = Fault, stop by coasting
P2.7.14	Stall current	0.00	2 x IH	A	1H		710	
P2.7.15	Stall time limit	1.00	120.00	s	15.00		711	
P2.7.16	Stall frequency limit	1.00	P2.1.2	Hz	25.00		712	
P2.7.17	Underload protection	0	3		0		713	0 = No response 1 = Warning 2 = Fault, stop acc. to 2.4.7 3 = Fault, stop by coasting
P2.7.18	UP fnom Torque	10.0	150.0	%	50.0		714	
P2.7.19	UP Zero frequency load	5.0	150.0	%	10.0		715	
P2.7.20	Underload protection time limit	2.00	600.00	s	20.00		716	
P2.7.21	Response to thermistor fault	0	3		2		732	0 = No response 1 = Warning 2 = Fault, stop acc. to 2.4.7 3 = Fault, stop by coasting
P2.7.22	Response to field-bus fault	0	3		2		733	See P2.7.21
P2.7.23	Response to slot fault	0	3				734	See P2.7.21

4.4.9 AUTORESTART PARAMETERS (CONTROL KEYPAD: MENU M2 -> G2.8)

Table 32: Autorestart parameters, G2.8

Index	Parameter	Min	Max	Unit	Default	Cust	ID	Description
P2.8.1	Wait time	0.10	10.00	s	0.50		717	
P2.8.2	Trial time	0.00	60.00	s	30.00		718	
P2.8.3	Start function	0	2		0		719	0 = Ramp 1 = Flying start 2 = According to P2.4.6
P2.8.4	Number of tries after undervoltage trip	0	10		0		720	
P2.8.5	Number of tries after overvoltage trip	0	10		0		721	
P2.8.6	Number of tries after overcurrent trip	0	3		0		722	
P2.8.7	Number of tries after 4mA reference trip	0	10		0		723	
P2.8.8	Number of tries after motor temperature fault trip	0	10		0		726	
P2.8.9	Number of tries after external fault trip	0	10		0		725	
P2.8.10	Number of tries after underload fault trip	0	10		0		738	

4.4.10 KEYPAD CONTROL (CONTROL KEYPAD: MENU M3)

The parameters for the selection of control place and direction on the keypad are listed below. See the Keypad control menu in the product's User Manual.

Table 33: Keypad control parameters, M3

Index	Parameter	Min	Max	Unit	Default	Cust	ID	Description
P3.1	Control place	1	3		1		125	1 = I/O terminal 2 = Keypad 3 = Fieldbus
P3.2	Keypad reference	P2.1.1	P2.1.2	Hz	0.00			
P3.3	Direction (on keypad)	0	1		0		123	
R3.4	Stop button	0	1		1		114	0 = Limited function of Stop button 1 = Stop button always enabled

4.4.11 SYSTEM MENU (CONTROL KEYPAD: MENU M6)

For parameters and functions related to the general use of the AC drive, such as application and language selection, customised parameter sets or information about the hardware and software, see the product's User Manual.

4.4.12 EXPANDER BOARDS (CONTROL KEYPAD: MENU M7)

The M7 menu shows the expander and option boards attached to the control board and board related information. For more information, see the product's User Manual.

5 PID CONTROL APPLICATION

5.1 INTRODUCTION

Select the PID Control Application in menu M6 on page S6.2

In the PID Control Application, there are two I/O terminal control places; place A is the PID controller and source B is the direct frequency reference. The control place A or B is selected with digital input DIN6.

The PID controller reference can be selected from the analogue inputs, fieldbus, motorised potentiometer, enabling the PID Reference 2 or applying the control keypad reference. The PID controller actual value can be selected from the analogue inputs, fieldbus, the actual values of the motor or through the mathematical functions of these.

The direct frequency reference can be used for the control without the PID controller and selected from the analogue inputs, fieldbus, motor potentiometer or keypad.

The PID Application is typically used to control level measuring or pumps and fans. In these applications, the PID Application provides a smooth control and an integrated measuring and controlling package where no additional components are needed.

- Digital inputs DIN2, DIN3, DIN5 and all the outputs are freely programmable.

Additional functions:

- Analogue input signal range selection
- Two frequency limit supervisions
- Torque limit supervision
- Reference limit supervision
- Second ramps and S-shape ramp programming
- Programmable start and stop functions
- DC-brake at start and stop
- Three prohibit frequency areas
- Programmable U/f curve and switching frequency
- Autorestart
- Motor thermal and stall protection: fully programmable; off, warning, fault
- Motor underload protection
- Input and output phase supervision
- Sum point frequency addition to PID output
- The PID controller can additionally be used from control places I/O B, keypad and fieldbus
- Easy ChangeOver function
- Sleep function

The parameters of the PID Control Application are explained in Chapter 9 *Parameter descriptions* of this manual. The explanations are arranged according to the individual ID number of the parameter.

5.2 CONTROL I/O

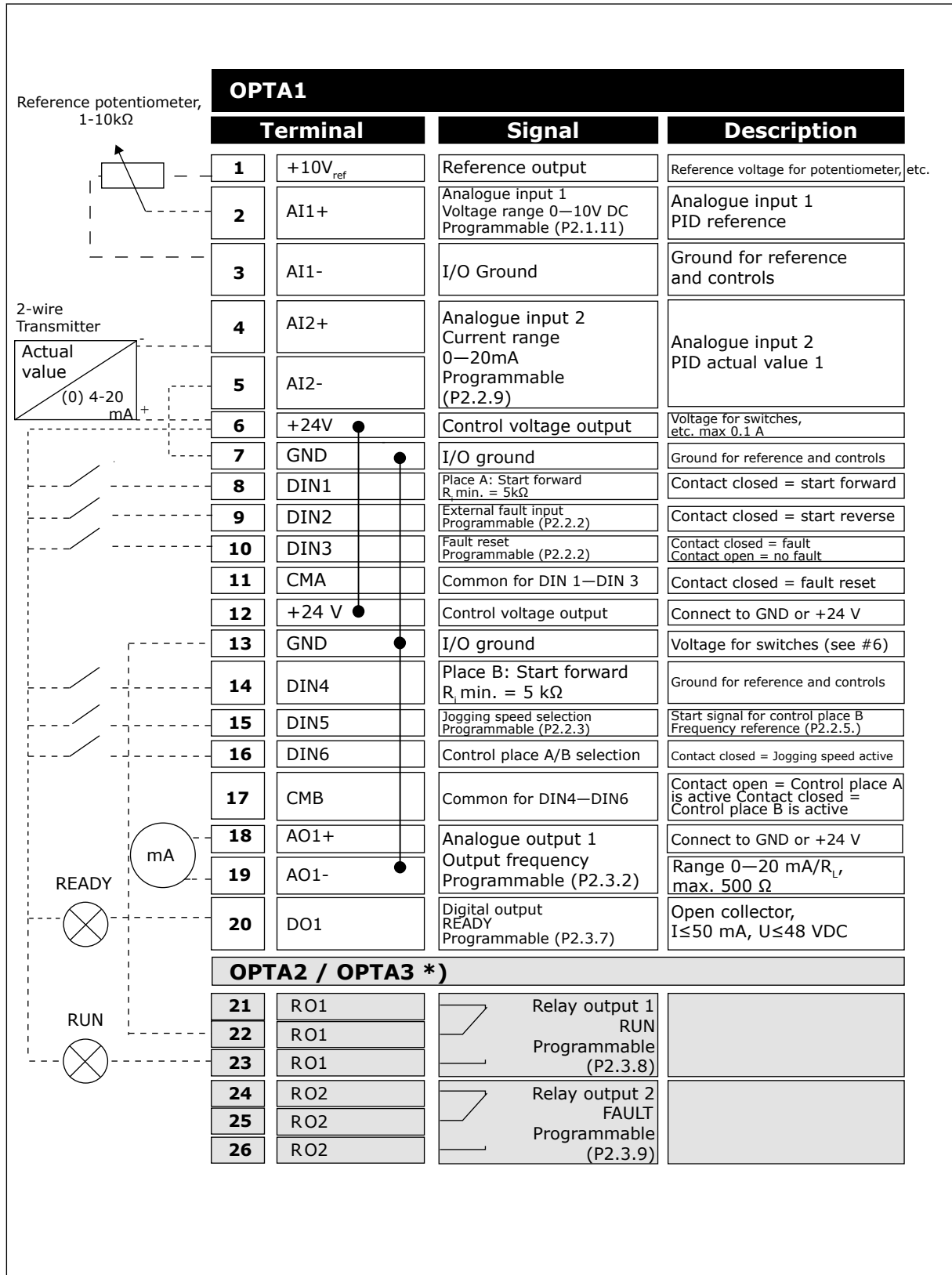

Fig. 13: PID application default I/O configuration (with 2-wire transmitter)

*) The option board A3 has no terminal for open contact on its second relay output (terminal 24 is missing).



NOTE!

See jumper selections below. More information in the product's User Manual.

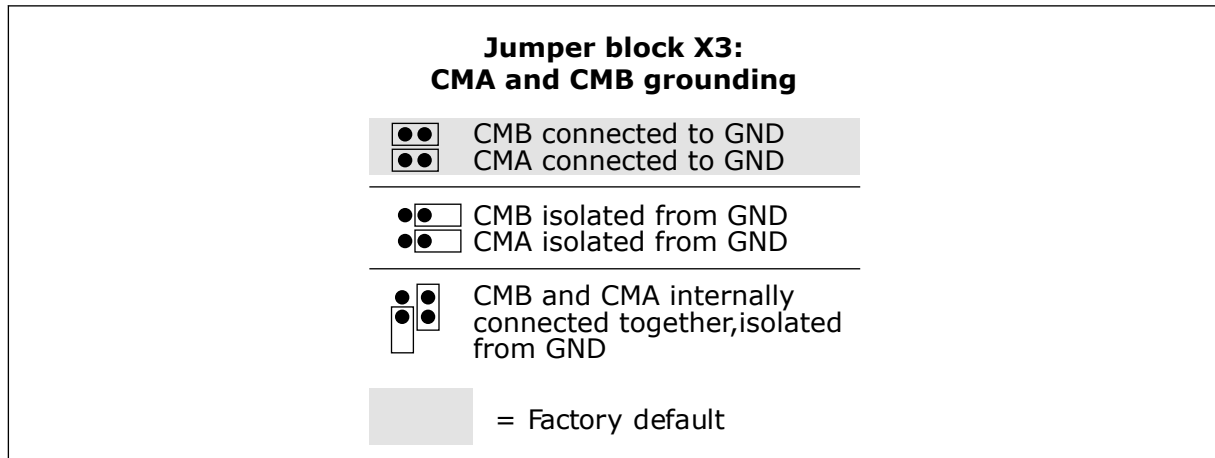

Fig. 14: Jumper selections

5.3 CONTROL SIGNAL LOGIC IN PID CONTROL APPLICATION

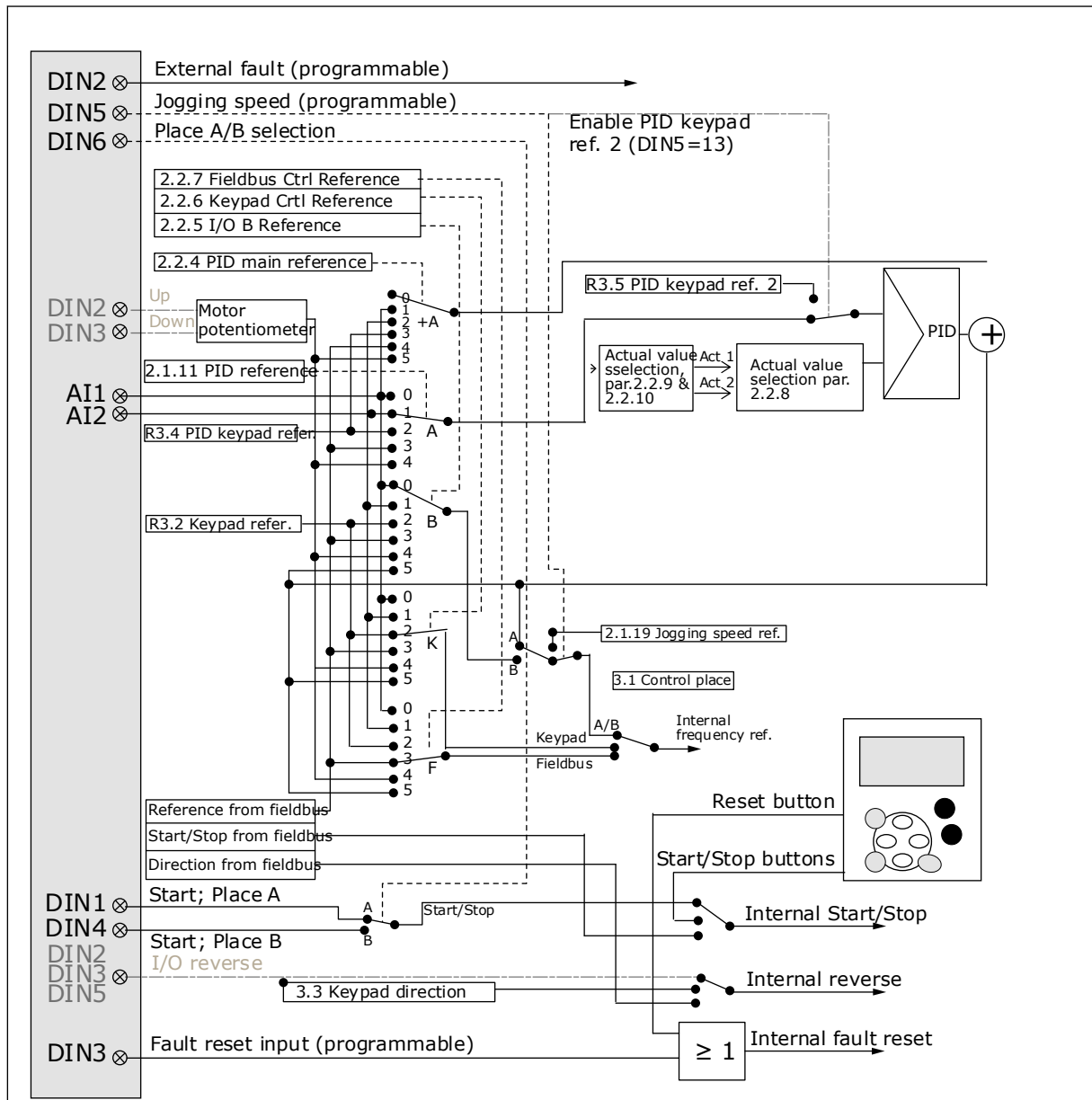

Fig. 15: Control signal logic of the PID Control Application

5.4 PID CONTROL APPLICATION - PARAMETER LISTS

5.4.1 MONITORING VALUES (CONTROL KEYPAD: MENU M1)

The monitoring values are the actual values of parameters and signals as well as statuses and measurements. Monitoring values cannot be edited.



NOTE!

The monitoring values V1.19 to V1.22 are available with the PID control application only.

Table 34: Monitoring values

Index	Monitoring value	Unit	Form	ID	Description
V1.1	Output frequency	Hz	###	1	
V1.2	Frequency reference	Hz	###	25	
V1.3	Motor speed	rpm	#	2	
V1.4	Motor current	A	Varies	3	
V1.5	Motor torque	%	##	4	
V1.6	Motor power	%	##	5	
V1.7	Motor voltage	V	##	6	
V1.8	DC link voltage	V	#	7	
1.9	Unit temperature	°C	#	8	
1.10	Motor temperature	%	##	9	
V1.11	Analogue input 1	V/mA	###	13	
V1.12	Analogue input 2	V/mA	###	14	
V1.13	Analogue input 3			27	
V1.14	Analogue input 4			28	
V1.15	DIN 1, 2, 3			15	
V1.16	DIN 4, 5, 6			16	
V1.17	D01, R01, R02			17	
V1.18	Analogue lout	mA	###	26	
V1.19	PID Reference	%		20	
V1.20	PID Actual value	%		21	
V1.21	PID Error value	%		22	
V1.22	PID Output	%		23	
V1.23	Special display for actual value			29	
V1.24	PT-100 Temperature	°C	##	42	
G1.25	Monitoring items				
V1.26.1	Current	A	Varies	1113	
V1.26.2	Torque	%	##	1125	

Table 34: Monitoring values

Index	Monitoring value	Unit	Form	ID	Description
V1.26.3	DC Voltage	V	#	44	
V1.26.4	Status Word			43	

5.4.2 BASIC PARAMETERS (CONTROL KEYPAD: MENU M2 -> G2.1)

Table 35: Basic parameters G2.1

Index	Parameter	Min	Max	Unit	Default	Cust	ID	Description
P2.1.1	Min frequency	0.00	P2.1.2	Hz	0.00		101	
P2.1.2	Max frequency	P2.1.1	320.00	Hz	50.00		102	
P2.1.3	Acceleration time 1	0.1	3000.0	s	0.0		103	
P2.1.4	Deceleration time 1	0.1	3000.0	s	0.0		104	
P2.1.5	Current limit	0.1 x IH	2 x IH	A	IL		107	
P2.1.6 *	Nominal voltage of the motor	180	690	V	NX2: 230V NX5: 400V NX6: 690V		110	
P2.1.7 *	Nominal frequency of the motor	8.00	320.00	Hz	50.00		111	
P2.1.8 *	Nominal speed of the motor	24	20 000	rpm	1440		112	
P2.1.9 *	Nominal current of the motor	0.1 x IH	2 X IH	A	IH		113	
P2.1.10 *	Motor cos phi	0.30	1.00		0.85		120	
P2.1.11 *	PID controller reference signal (Place A)	0	4		1		332	0 = AI1 1 = AI2 2 = PID ref from Keypad control page, P3.4 3 = PID ref from fieldbus (Process-DataIN 1) 4 = Motor potentiometer
P2.1.12	PID controller gain	0.0	1000.0	%	100.0		118	
P2.1.13	PID controller I-time	0.00	320.00	s	1.00		119	
P2.1.14	PID controller D-time	0.00	100.00	s	0.00		132	

Table 35: Basic parameters G2.1

Index	Parameter	Min	Max	Unit	Default	Cust	ID	Description
P2.1.15	Sleep frequency	0.00	P2.1.2	Hz	10.00		1016	
P2.1.16	Sleep delay	0	3600	s	30		1017	
P2.1.17	Wake up level	0.00	100.00	%	25.00		1018	
P2.1.18	Wake up function	0	1		0		1019	0 = Wake-up at fall below wake up level [2.1.17] 1 = Wake-up at exceeded wake up level [2.1.17]
P2.1.19	Jogging speed reference	0.00	P2.1.2	Hz	10.00		124	

* = Parameter value can only be changed after the AC drive has been stopped.

5.4.3 INPUT SIGNALS

Table 36: Input signals, G2.2

Index	Parameter	Min	Max	Unit	Default	Cust	ID	Description
P2.2.1 **	DIN2 function	0	13		1		319	0 = Not used 1 = External fault cc 2 = External fault oc 3 = Run enable 4 = Acc/Dec time selection 5 = CP: I/O terminal (ID125) 6 = CP: Keypad (ID125) 7 = CP: Fieldbus (ID125) 8 = Forward/Reverse 9 = Jogging frequency (cc) 10 = Fault reset (cc) 11 = Acc/Dec prohibit (cc) 12 = DC braking command 13 = Motor pot. UP (cc)
P2.2.2 **	DIN3 function	0	13		10		301	See above except: 13 = Motor pot. DOWN (cc)
P2.2.3 **	DIN5 function	0	13		9		330	See above except: 13 = Enable PID reference 2
P2.2.4 **	PID sum point reference	0	7		0		376	0 = Direct PID output value 1 = AI1+PID output 2 = AI2+PID output 3 = AI3+PID output 4 = AI4+PID output 5 = PID keypad +PID output 6 = Fieldbus+PID output (Process-DataIN3) 7 = Mot.pot.+PID output

Table 36: Input signals, G2.2

Index	Parameter	Min	Max	Unit	Default	Cust	ID	Description
P2.2.5 **	I/O B reference selection	0	7		1		343	0 = AI1 1 = AI2 2 = AI3 3 = AI4 4 = Keypad reference 5 = Fieldbus reference (FBSpeedReference) 6 = Motor potentiometer 7 = PID controller
P2.2.6 **	Keypad control reference selection	0	7		4		121	As in P2.2.5
P2.2.7 **	Fieldbus control reference selection	0	7		5		122	As in P2.2.5
P2.2.8 **	Actual value selection	0	7		0		333	0 = Actual value 1 1 = Actual 1 + Actual 2 2 = Actual 1 – Actual 2 3 = Actual 1 * Actual 2 4 = Min[Actual 1, Actual 2] 5 = Max[Actual 1, Actual 2] 6 = Mean[Actual1, Actual2] 7 = Sqrt (Act1) + Sqrt (Act2)
P2.2.9 **	Actual value 1 selection	0	10		2		334	0 = Not used 1 = AI1 signal (c-board) 2 = AI2 signal (c-board) 3 = AI3 4 = AI4 5 = Fieldbus ProcessDataIN2 6 = Motor torque 7 = Motor speed 8 = Motor current 9 = Motor power 10 = Encoder frequency

Table 36: Input signals, G2.2

Index	Parameter	Min	Max	Unit	Default	Cust	ID	Description
P2.2.10 **	Actual value 2 input	0	10		0		335	0 = Not used 1 = AI1 signal 2 = AI2 signal 3 = AI3 4 = AI4 5 = Fieldbus ProcessDataIN3 6 = Motor torque 7 = Motor speed 8 = Motor current 9 = Motor power 10 = Encoder Frequency
P2.2.11	Actual value 1 minimum scale	-1600.0	1600.0	%	0.0		336	
P2.2.12	Actual value 1 maximum scale	-1600.0	1600.0	%	100.0		337	
P2.2.13	Actual value 2 minimum scale	-1600.0	1600.0	%	0.0		338	
P2.2.14	Actual value 2 maximum scale	-1600.0	1600.0	%	100.0		339	
P2.2.15 ***	AI1 signal selection	0.1	E.10		A.1		377	
P2.2.16	AI1 signal range	0	2		0		320	0 = 0–10 V (0–20 mA*) 1 = 2–10 V (4–20 mA*) 2 = Custom range*
P2.2.17	AI1 custom minimum setting	-160.00	160.00	%	0.00		321	
P2.2.18	AI1 custom maximum setting	-160.00	160.00	%	100.0		322	
P2.2.19	AI1 inversion	0	1		0		323	0 = Not inverted 1 = Inverted
P2.2.20	AI1 filter time	0.00	10.00	s	0.10		324	
P2.2.21	AI2 signal selection	0.1	E.10		A.2		388	0 = 0–20 mA (0–10 V*) 1 = 4–20 mA (2–10 V*) 2 = Custom range*
P2.2.22	AI2 signal range	0	2		1		325	0 = 0–20 mA* 1 = 4–20 mA* 2 = Customised*

Table 36: Input signals, G2.2

Index	Parameter	Min	Max	Unit	Default	Cust	ID	Description
P2.2.23	AI2 custom minimum setting	-160.00	160.00	%	0.00		326	
P2.2.24	AI2 custom maximum setting	-160.00	160.00	%	0.00		327	
P2.2.25	AI2 inversion	0	1		0		328	0 = Not inverted 1 = Inverted
P2.2.26	AI2 filter time	0.00	10.00	s	0.10		329	
P2.2.27	Motor potentiometer ramp time	0.1	2000.0	Hz/s	10.0		331	
P2.2.28	Motor potentiometer frequency reference memory reset	0	2		1		367	0 = No reset 1 = Reset if stopped or powered down 2 = Reset if powered down
P2.2.29	Motor potentiometer PID reference memory reset	0	2		0		370	0 = No reset 1 = Reset if stopped or powered down 2 = Reset if powered down
P2.2.30	PID minimum limit	-1600.0	P2.2.31	%	0.0		359	
P2.2.31	PID maximum limit	P2.2.30	1600.0	%	100.0		360	
P2.2.32	Error value inversion	0	1		0		340	0 = No inversion 1 = Inversion
P2.2.33	PID reference rising time	0.1	100.0	s	5.0		341	
P2.2.34	PID reference falling time	0.1	100.0	s	5.0		342	
P2.2.35	Reference scaling minimum value, place B	0.00	320.0	Hz	0.00		344	
P2.2.36	Reference scaling maximum value, place B	0.00	320.0	Hz	0.00		345	
P2.2.37	Easy changeover	0	1		0		366	0 = Keep reference 1 = Copy actual reference

Table 36: Input signals, G2.2

Index	Parameter	Min	Max	Unit	Default	Cust	ID	Description
P2.2.38 ***	AI3 signal selection	0.1	E.10		0.1		141	
P2.2.39	AI3 signal range	0	1		1		143	0 = Signal range 0 –10 V 1 = Signal range 2 –10 V
P2.2.40	AI3 inversion	0	1		0		151	0 = Not inverted 1 = Inverted
P2.2.41	AI3 filter time	0.00	10.00	s	0.10		142	
P2.2.42 ***	AI4 signal selection	0.1	E.10		0.1		152	
P2.2.43	AI4 signal range	0	1		1		154	0 = Signal range 0 –10 V 1 = Signal range 2 –10 V
P2.2.44	AI4 inversion	0	1		0		162	0 = Not inverted 1 = Inverted
P2.2.45	AI4 filter time	0.00	10.00	s	0.10		153	
P2.2.46	Actual value special display minimum	0	30000		0		1033	
P2.2.47	Actual value special display maximum	0	30000		100		1034	
P2.2.48	Actual value special display decimals	0	4		1		1035	
P2.2.49	Actual value special display unit	0	29		4		1036	See ID1036 in Chapter 9 <i>Parameter descriptions</i> .

CP = control place

cc = contact

oc = opening contact

* = Remember to place jumpers of block X2 accordingly. See the product's User Manual.

** = Parameter value can only be changed after the FC has been stopped.

*** = Use TTF method to program these parameters.

5.4.4 OUTPUT SIGNALS (CONTROL KEYPAD: MENU M2 -> G2.3)

Table 37: Output signals, G2.3

Index	Parameter	Min	Max	Unit	Default	Cust	ID	Description
P2.3.1 *	A01 signal selection	0.1	E.10		A.1		464	
P2.3.2	Analogue output function	0	14		1		307	0 = Not used 1 = Output freq. (0-fmax) 2 = Freq. reference (0-fmax) 3 = Motor speed (0-Motor nominal speed) 4 = Motor current (0-InMotor) 5 = Motor torque (0-TnMotor) 6 = Motor power (0-PnMotor) 7 = Motor voltage (0-UnMotor) 8 = DC-link volt (0-1000V) 9 = PID controller ref. value 10 = PID contr. act. value 1 11 = PID contr. act. value 2 12 = PID contr. error value 13 = PID controller output 14 = PT100 temperature
P2.3.3	Analogue output filter time	0.00	10.00	s	1.00		308	
P2.3.4	Analogue output inversion	0	1		0		309	0 = Not inverted 1 = Inverted
P2.3.5	Analogue output minimum	0	1		0		310	0 = 0 mA (0 V) 1 = 4 mA (2 V)
P2.3.6	Analogue output scale	10	1000	%	100		311	

Table 37: Output signals, G2.3

Index	Parameter	Min	Max	Unit	Default	Cust	ID	Description
P2.3.7	Digital output 1 function	0	23		1		312	0 = Not used 1 = Ready 2 = Run 3 = Fault 4 = Fault inverted 5 = FC overheat warning 6 = Ext. fault or warning 7 = Ref. fault or warning 8 = Warning 9 = Reversed 10 = Preset speed 1 11 = At speed 12 = Mot. regulator active 13 = OP freq. limit superv. 1 14 = OP freq. limit superv.2 15 = Torque limit superv. 16 = Ref. limit superv. 17 = Ext. brake control 18 = Control place: IO 19 = FC temp. limit superv. 20 = Unrequested rotation direction
P2.3.7	Digital output 1 function	0	23		1		312	21 = Ext. brake control inverted 22 = Thermistor fault/warn. 23 = Fieldbus DIN1
P2.3.8	RO1 function	0	23		2		313	As parameter 2.3.7
P2.3.9	RO2 function	0	23		3		314	As parameter 2.3.7
P2.3.10	Output frequency limit 1 supervision	0	2		0		315	0 = No limit 1 = Low limit supervision 2 = High limit supervision
P2.3.11	Output frequency limit 1; Supervised value	0.00	320.00	Hz	0.00		316	

Table 37: Output signals, G2.3

Index	Parameter	Min	Max	Unit	Default	Cust	ID	Description
P2.3.12	Output frequency limit 2 supervision	0	2		0		346	0 = No limit 1 = Low limit supervision 2 = High limit supervision
P2.3.13	Output frequency limit 2; Supervision value	0.00	320.00	Hz	0.00		347	
P2.3.14	Torque limit supervision function	0	2		0		348	0 = No 1 = Low limit 2 = High limit
P2.3.15	Torque limit supervision value	-300.0	300.0	%	100.0		349	
P2.3.16	Reference limit supervision function	0	2		0		350	0 = No 1 = Low limit 2 = High limit
P2.3.17	Reference limit supervision value	0.0	100.0	%	0.0		351	
P2.3.18	External brake Off-delay	0.0	100.0	s	0.5		352	
P2.3.19	External brake On-delay	0.0	100.0	s	1.5		353	
P2.3.20	Frequency converter temperature limit supervision	0	2		0		354	0 = No 1 = Low limit 2 = High limit
P2.3.21	Frequency converter temperature supervised value	-10	100	°C	40		355	
P2.3.22	Analogue output 2 scaling	0.1	E.10		0.1		471	
P2.3.23	Analogue output 2 function	0	14		4		472	As parameter 2.3.2
P2.3.24	Analogue output 2 filter time	0.00	10.00	s	1.00		473	
P2.3.25	Analogue output 2 inversion	0	1		0		474	0 = Not inverted 1 = Inverted
P2.3.26	Analogue output 2 minimum	0	1		0		475	0 = 0 mA (0 V) 1 = 4 mA (2 V)

Table 37: Output signals, G2.3

Index	Parameter	Min	Max	Unit	Default	Cust	ID	Description
P.2.3.27	Analogue output 2 scaling	10	1000	%	1.00		476	

* = Use TTF method to program these parameters

5.4.5 DRIVE CONTROL PARAMETERS (CONTROL KEYPAD: MENU M2 -> G2.4)

Table 38: Drive control parameters, G2.4

Index	Parameter	Min	Max	Unit	Default	Cust	ID	Description
P2.4.1	Ramp 1 shape	0.0	10.0	s	0.1		500	0 = Linear >0 = S-curve ramp time
P2.4.2	Ramp 2 shape	0.0	10.0	s	0.0		501	0 = Linear >0 = S-curve ramp time
P2.4.3	Acceleration time 2	0.1	3000.0	s	1.0		502	
P2.4.4	Deceleration time 2	0.1	3000.0	s	1.0		503	
P2.4.5	Brake chopper	0	4		0		504	0 = Disabled 1 = Used when running 2 = External brake chopper 3 = Used when stopped/running 4 = used when running (no testing)
P2.4.6	Start function	0	2		0		505	0 = Ramp 1 = Flying start 2 = Conditional flying start
P2.4.7	Stop function	0	3		0		506	0 = Coasting 1 = Ramp 2 = Ramp+Run enable coast 3 = Coast+Run enable ramp
P2.4.8	DC braking current	0.00	IL	A	0.7 x IH		507	
P2.4.9	DC braking time at stop	0.00	600.00	s	0.00		508	
P2.4.10	Frequency to start DC braking during ramp stop	0.10	10.00	Hz	1.50		515	
P2.4.11	DC braking time at start	0.00	600.00	s	0.00		516	
P2.4.12 *	Flux brake	0	1		0		520	0 = Off 0 = On

Table 38: Drive control parameters, G2.4

Index	Parameter	Min	Max	Unit	Default	Cust	ID	Description
P2.4.13	Flux braking current	0.00	IL	A	IH		519	

5.4.6 PROHIBIT FREQUENCY PARAMETERS (CONTROL KEYPAD: MENU M2 -> G2.5)**Table 39: Prohibit frequency parameters, G2.5**

Index	Parameter	Min	Max	Unit	Default	Cust	ID	Description
P2.5.1	Prohibit frequency range 1 low limit	-1.00	320.00	Hz	0.00		509	0 = Not used
P2.5.2	Prohibit frequency range 1 high limit	0.00	320.00	Hz	0.00		510	0 = Not used
P2.5.3	Prohibit frequency range 2 low limit	0.00	320.00	Hz	0.00		511	0 = Not used
P2.5.4	Prohibit frequency range 2 high limit	0.00	320.00	Hz	0.00		512	0 = Not used
P2.5.5	Prohibit frequency range 3 low limit	0.00	320.00	Hz	0.00		513	0 = Not used
P2.5.6	Prohibit frequency range 3 high limit	0.00	320.00	Hz	0.00		514	0 = Not used
P2.5.7	Prohibit acc./dec. ramp	0.1	10.0	x	1.0		518	

5.4.7 MOTOR CONTROL PARAMETERS (CONTROL KEYPAD: MENU M2 -> G2.6)

Table 40: Motor control parameters, G2.6

Index	Parameter	Min	Max	Unit	Default	Cust	ID	Description
P2.6.1	Motor control mode	0	1/3		0		600	0 = Frequency control 1 = Speed control NXP: 2 = Not used 3 = Closed loop speed ctrl 4 = Closed loop torque control
P2.6.2	U/f optimisation	0	1		0		109	NXP: 0 = Not used 1 = Automatic torque boost
P2.6.3	U/f ratio selection	0	3		0		108	0 = Linear 1 = Squared 2 = Programmable 3 = Linear with flux optim.
P2.6.4	Field weakening point	8.00	320.00	Hz	50.00		602	
P2.6.5	Voltage at field weakening point	10.00	200.00	%	100.00		603	
P2.6.6	U/f curve midpoint frequency	0.00	P2.6.4	Hz	50.00		604	
P2.6.7	U/f curve midpoint voltage	0.00	100.00	%	100.00		605	
P2.6.8	Output voltage at zero frequency	0.00	40.00	%	Varies		606	
P2.6.9	Switching frequency	1	Varies	kHz	Varies		601	
P2.6.10	Overvoltage controller	0	2		1		607	0 = Not used 1 = Used (no ramping) 2 = Used (ramping)
P2.6.11	Undervoltage controller	0	1		1		608	0 = Not used 1 = Used 2 = Used (ramping to zero)
P2.6.12	Load drooping	0.00	100.00	%	0.00		620	
P2.6.13	Identification	0	1/2		0		631	

Table 40: Motor control parameters, G2.6

Index	Parameter	Min	Max	Unit	Default	Cust	ID	Description
Closed Loop parameter group 2.6.14								
P2.6.14.1	Magnetizing current	0.00	2 x IH	A	0.00		612	
P2.6.14.2	Speed control P gain	1	1000		30		613	
P2.6.14.3	Speed control I time	0.0	3200.0	ms	30.0		614	
P2.6.14.5	Acceleration compensation	0.00	300.00	%	0.00		626	
P2.6.14.6	Slip adjust	0	500	%	100		619	
P2.6.14.7	Magnetizing current at start	0,00	IL	A	0.00		627	
P2.6.14.8	Magnetizing time at start	0	60000	ms	0		628	
P2.6.14.9	0-speed time at start	0	32000	ms	100		615	
P2.6.14.10	0-speed time at stop	0	32000	ms	100		616	
P2.6.14.11	Start-up torque	0	3		0		621	0 = Not used 1 = Torque memory 2 = Torque reference 3 = Start-up torque fwd/rev
P2.6.14.12	Start-up torque FWD	-300.0	300.00	%	0.0		633	
P2.6.14.13	Start-up torque REV	-300.0	300.0	%	0.0		634	
P2.6.14.15	Encoder filter time	0.0	100.0	ms	0.0		618	
P2.6.14.17	Current control P gain	0.00	100.00	%	40.00		617	
Identification parameter group 2.6.15								
P2.6.15.1	Speed step	-50.0	50.0	%	0.0		1252	

5.4.8 PROTECTIONS (CONTROL KEYPAD: MENU M2 -> G2.7)

Table 41: Protections, G2.7

Index	Parameter	Min	Max	Unit	Default	Cust	ID	Description
P2.7.1	Response to 4 mA reference fault	0	5		4		700	0 = No response 1 = Warning 2 = Warning+Previous Freq. 3 = Wrng+Preset-Freq 2.7.2 4 = Fault, stop acc. to 2.4.7 5 = Fault, stop by coasting
P2.7.2	4 mA reference fault frequency	0.00	P2.1.2	Hz	0.00		728	
P2.7.3	Response to external fault	0	3		2		701	0 = No response 1 = Warning 2 = Fault, stop acc. to 2.4.7
P2.7.4	Input phase supervision	0	3		0		730	3 = Fault, stop by coasting
P2.7.5	Response to undervoltage fault	0	1		0		727	0 = Fault stored in history Fault not stored
P2.7.6	Output phase supervision	0	3		2		702	0 = No response 1 = Warning 2 = Fault, stop acc. to 2.4.7
P2.7.7	Earth fault protection	0	3		2		703	3 = Fault, stop by coasting
P2.7.8	Thermal protection of the motor	0	3		2		704	
P2.7.9	Motor ambient temperature factor	-100.0	100.0	%	0.0		705	
P2.7.10	Motor cooling factor at zero speed	0.0	150.0	%	40.0		706	
P2.7.11	Motor thermal time constant	1	200	min	Varies		707	
P2.7.12	Motor duty cycle	0	150	%	100		708	
P2.7.13	Stall protection	0	3		1		709	0 = No response 1 = Warning 2 = Fault, stop acc. to 2.4.7 3 = Fault, stop by coasting
P2.7.14	Stall current	0.00	2 x IH	A	1H		710	

Table 41: Protections, G2.7

Index	Parameter	Min	Max	Unit	Default	Cust	ID	Description
P2.7.15	Stall time limit	1.00	120.00	s	15.00		711	
P2.7.16	Stall frequency limit	1.0	P2.1.2	Hz	25.0		712	
P2.7.17	Underload protection	0	3		0		713	0 = No response 1 = Warning 2 = Fault, stop acc. to 2.4.7 3 = Fault, stop by coasting
P2.7.18	UP from Torque	10.0	150.0	%	50.0		714	
P2.7.19	UP Zero frequency load	5.0	150.0	%	10.0		715	
P2.7.20	Underload protection time limit	2.00	600.00	s	20.00		716	
P2.7.21	Response to thermistor fault	0	3		2		732	0 = No response 1 = Warning 2 = Fault, stop acc. to 2.4.7 3 = Fault, stop by coasting
P2.7.22	Response to field-bus fault	0	3		2		733	See P2.7.21
P2.7.23	Response to slot fault	0	3		2		734	See P2.7.21
P2.7.24	No. of PT100 inputs	0	5		0		739	
P2.7.25	Response to PT100 fault	0	3		0		740	0 = No response 1 = Warning 2 = Fault, stop acc. to 2.4.7 3 = Fault, stop by coasting
P2.7.26	PT100 warning limit	-30.0	200.0	°C	120.0		741	
P2.7.27	PT100 fault limit	-30.0	200.0	°C	130.0		742	

5.4.9 AUTORESTART PARAMETERS (CONTROL KEYPAD: MENU M2 -> G2.8)

Table 42: Autorestart parameters, G2.8

Index	Parameter	Min	Max	Unit	Default	Cust	ID	Description
P2.8.1	Wait time	0.10	10.00	s	0.50		717	
P2.8.2	Trial time	0.00	60.00	s	30.00		718	
P2.8.3	Start function	0	2		0		719	0 = Ramp 1 = Flying start 2 = According to P2.4.6
P2.8.4	Number of tries after undervoltage trip	0	10		0		720	
P2.8.5	Number of tries after overvoltage trip	0	10		0		721	
P2.8.6	Number of tries after overcurrent trip	0	3		0		722	
P2.8.7	Number of tries after 4mA reference trip	0	10		0		723	
P2.8.8	Number of tries after motor temperature fault trip	0	10		0		726	
P2.8.9	Number of tries after external fault trip	0	10		0		725	
P2.8.10	Number of tries after underload fault trip	0	10		0		738	

5.4.10 KEYPAD CONTROL (CONTROL KEYPAD: MENU M3)

The parameters for the selection of control place and direction on the keypad are listed below. See the Keypad control menu in the product's User Manual.

Table 43: Keypad control parameters, M3

Index	Parameter	Min	Max	Unit	Default	Cust	ID	Description
P3.1	Control place	1	3		1		125	1 = I/O terminal 2 = Keypad 3 = Fieldbus
P3.2	Keypad reference	P2.1.1	P2.1.2	Hz	0.00			
P3.3	Direction (on keypad)	0	1		0		123	
P3.4	PID reference	0.00	100.00	%	0.00		167	
P3.5	PID reference 2	0.00	100.00	%	0.00		168	
R3.4	Stop button	0	1		1		114	0 = Limited function of Stop button 1 = Stop button always enabled

5.4.11 SYSTEM MENU (CONTROL KEYPAD: MENU M6)

For parameters and functions related to the general use of the AC drive, such as application and language selection, customised parameter sets or information about the hardware and software, see the product's User Manual.

5.4.12 EXPANDER BOARDS (CONTROL KEYPAD: MENU M7)

The M7 menu shows the expander and option boards attached to the control board and board related information. For more information, see the product's User Manual.

6 MULTI-PURPOSE CONTROL APPLICATION

6.1 INTRODUCTION

Select the Multi-purpose Control Application in menu M6 on page S6.2.

The Multi-purpose Control application provides a wide range of parameters for controlling motors. It can be used for various kinds of different processes, where wide flexibility of I/O signals is needed and PID control is not necessary (if you need PID control functions, use the PID Control Application or Pump and Fan Control Application).

The frequency reference can be selected e.g. from the analogue inputs, joystick control, motor potentiometer and from a mathematical function of the analogue inputs. There are parameters also for Fieldbus communication. Multi-step speeds and jogging speed can also be selected if digital inputs are programmed for these functions.

- The digital inputs and all the outputs are freely programmable and the application supports all I/O-boards

Additional functions:

- Analogue input signal range selection
- Two frequency limit supervisions
- Torque limit supervision
- Reference limit supervision
- Second ramps and S-shape ramp programming
- Programmable Start/Stop and Reverse logic
- DC-brake at start and stop
- Three prohibit frequency areas
- Programmable U/f curve and switching frequency
- Autorestart
- Motor thermal and stall protection: fully programmable; off, warning, fault
- Motor underload protection
- Input and output phase supervision
- Joystick hysteresis
- Sleep function

NXP functions:

- Power limit functions
- Different power limits for motoring and generating side
- Master Follower function
- Different torque limits for motoring and generating side
- Cooling monitor input from heat exchange unit
- Brake monitoring input and actual current monitor for immediate brake close.
- Separate speed control tuning for different speeds and loads
- Inching function two different references
- Possibility to connect the FB Process data to any parameter and some monitoring values
- Identification parameter can be adjusted manually

The parameters of the Multi-Purpose Control Application are explained in Chapter 9 *Parameter descriptions* of this manual. The explanations are arranged according to the individual ID number of the parameter.

6.2 CONTROL I/O

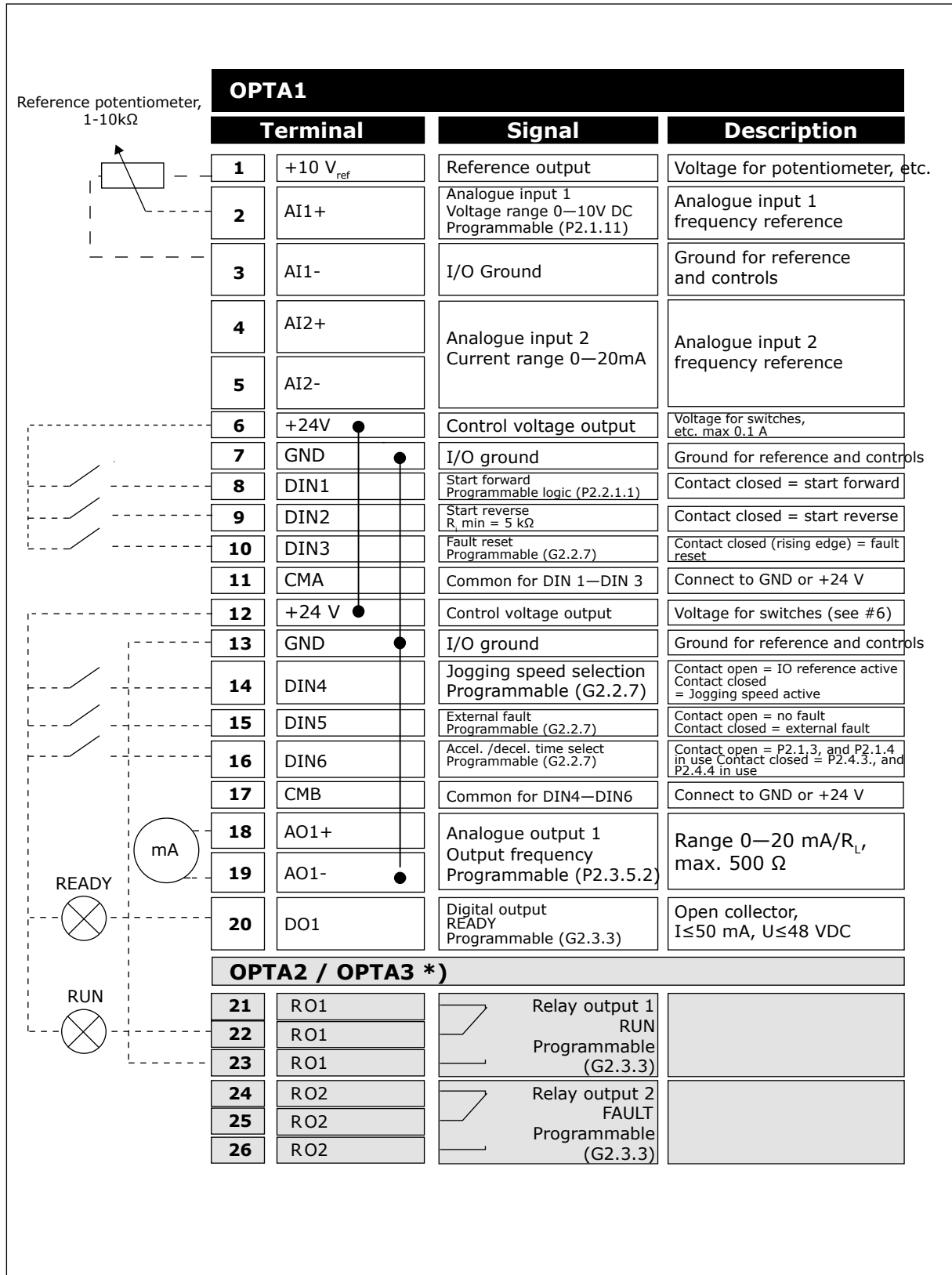

Fig. 16: Multi-purpose control application default I/O configuration and connection example

*) The option board A3 has no terminal for open contact on its second relay output (terminal 24 is missing).

**NOTE!**

See jumper selections below. More information in the product's User Manual.

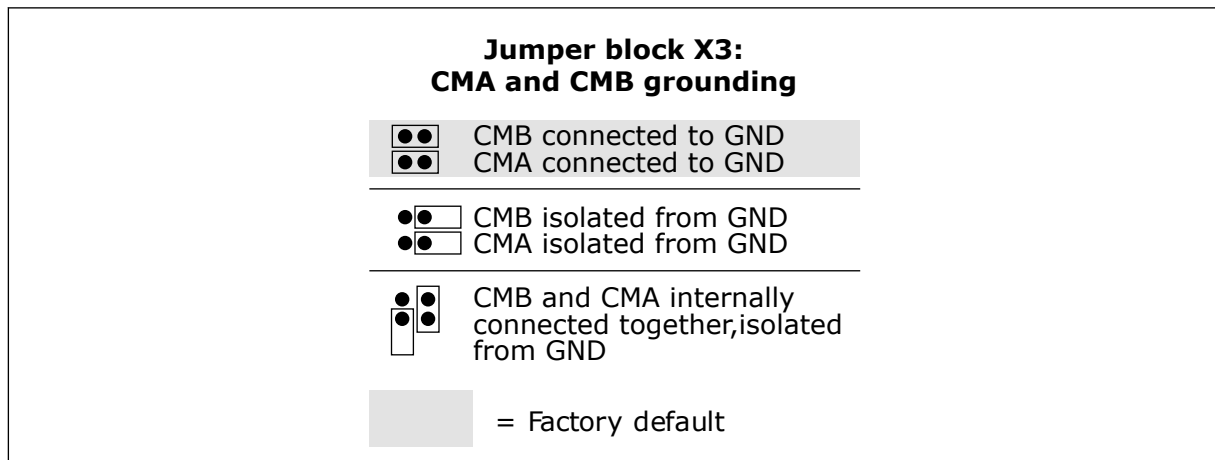

Fig. 17: Jumper selections

6.3 CONTROL SIGNAL LOGIC IN MULTI-PURPOSE CONTROL APPLICATION

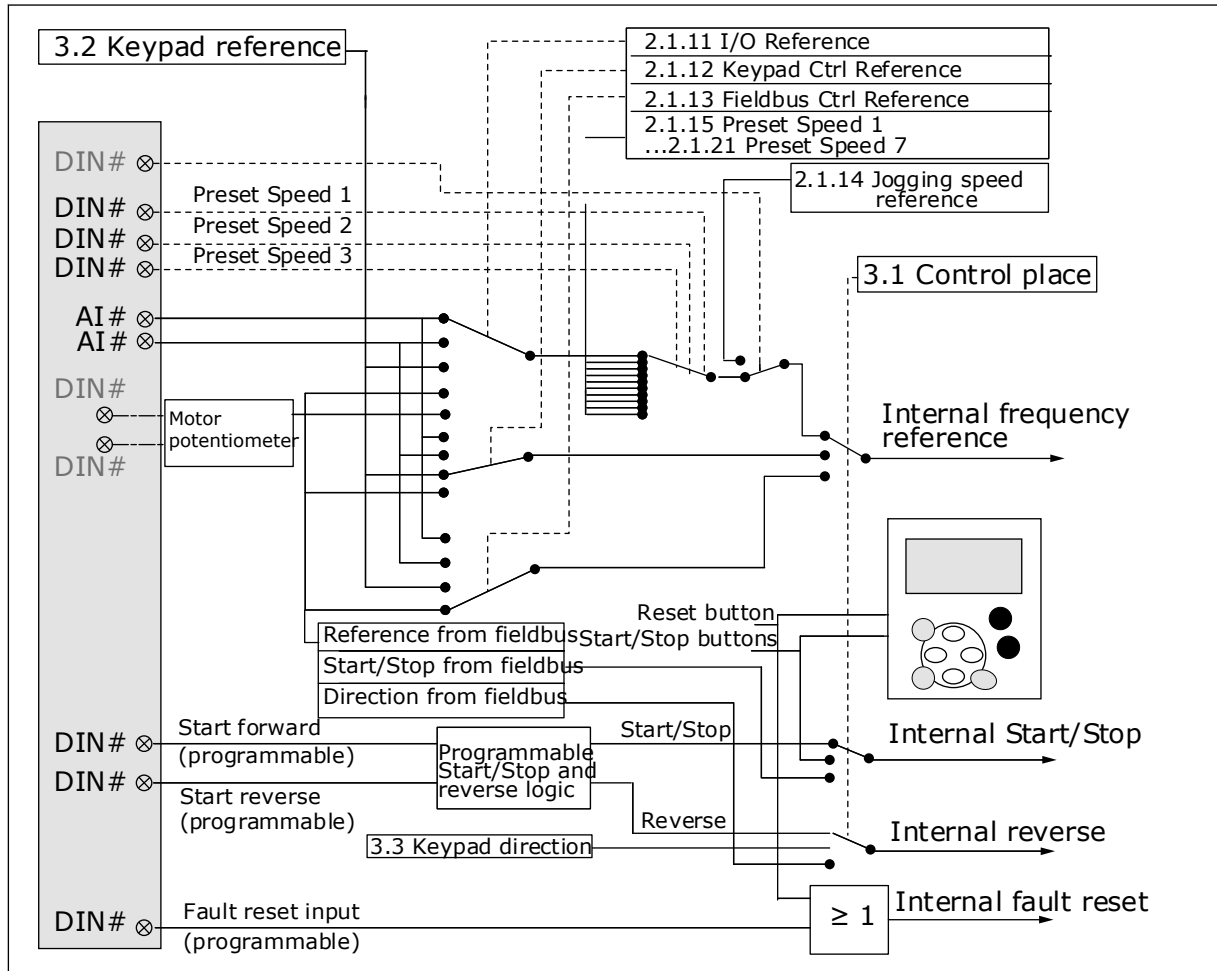

Fig. 18: Control signal logic of the Multi-purpose Control Application

6.4 MULTI-PURPOSE CONTROL APPLICATION - PARAMETER LISTS

6.4.1 MONITORING VALUES (CONTROL KEYPAD: MENU M1)

The monitoring values are the actual values of parameters and signals as well as statuses and measurements. Monitoring values marked with asterisk (*) can be controlled from the fieldbus.

Table 44: Monitoring values, NXS drives

Index	Monitoring value	Unit	Form	ID	Description
V1.1	Output frequency	Hz	###	1	
V1.2	Frequency reference	Hz	###	25	
V1.3	Motor speed	rpm	#	2	
V1.4	Motor current	A	Varies	3	
V1.5	Motor torque	%	##	4	
V1.6	Motor power	%	##	5	
V1.7	Motor voltage	V	##	6	
V1.8	DC link voltage	V	#	7	
V1.9	Unit temperature	°C	#	8	
V1.10	Motor temperature	%	##	9	
V1.11	Analogue input 1	V/mA	##	13	
V1.12	Analogue input 2	V/mA	##	14	
V1.13	DIN 1, 2, 3			15	
V1.14	DIN 4, 5, 6			16	
V1.15	Analogue output 1	V/mA	###	26	
V1.16	Analogue input 3	V/mA	###	27	
V1.17	Analogue input 4	V/mA	###	28	
V1.18	Torque reference	%	##	18	
V1.19	Sensor max temp.	°C	##	42	
G1.20	Multimonitoring items				
V1.21.1	Current	A	Varies	1113	
V1.21.2	Torque	%	##	1125	
V1.21.3	DC Voltage	V	#	44	
V1.21.4	Status Word			43	See Table 53 Application Status word content.
V1.21.5	Fault History		#	37	
V1.21.6	Motor Current	A	##	45	

Table 44: Monitoring values, NXS drives

Index	Monitoring value	Unit	Form	ID	Description
V1.21.7	Warnig			74	
V1.21.8	Sensor 1 Temp	°C	#. #	50	
V1.21.9	Sensor 2 Temp	°C	#. #	51	
V1.21.10	Sensor 3 Temp	°C	#. #	52	
V1.21.25	Sensor 4 Temp	°C	#. #	69	
V1.21.26	Sensor 5 Temp	°C	#. #	70	
V1.21.27	Sensor 6 Temp	°C	#. #	71	

Table 45: Monitoring values, NXP drives

Index	Monitoring value	Unit	Form	ID	Description
V1.1	Output frequency	Hz	###	1	
V1.2	Frequency reference	Hz	###	25	
V1.3	Motor speed	rpm	#	2	
V1.4	Motor current	A	Varies	3	
V1.5	Motor torque	%	##	4	
V1.6	Motor power	%	##	5	
V1.7	Motor voltage	V	##	6	
V1.8	DC link voltage	V	#	7	
V1.9	Unit temperature	°C	#	8	
V1.10	Motor temperature	%	##	9	
V1.11 *	Analogue input 1	V/mA	##	13	
V1.12 *	Analogue input 2	V/mA	##	14	
V1.13	DIN 1, 2, 3			15	
V1.14	DIN 4, 5, 6			16	
V1.15	Analogue output 1	V/mA	###	26	
V1.16 *	Analogue input 3	V/mA	###	27	
V1.17 *	Analogue input 4	V/mA	###	28	
V1.18	Torque reference	%	##	18	
V1.19	Sensor max temp	C°	##	42	
G1.20	Multimonitoring items				
V1.21.1	Current	A	Varies	1113	
V1.21.2	Torque	%	##	1125	
V1.21.3	DC Voltage	V	#	44	
V1.21.4	Status Word			43	See Table 53 Application Status word content.
V1.21.5	Encoder 1 Frequency	Hz	###	1124	
V1.21.6	Shaft Rounds	r	#	1170	See ID1090

Table 45: Monitoring values, NXP drives

Index	Monitoring value	Unit	Form	ID	Description
V1.21.7	Shaft Angle	Deg	#. #	1169	See ID1090
V1.21.8	Sensor 1 Temp	°C	#. #	50	
V1.21.9	Sensor 2 Temp	°C	#. #	51	
V1.21.10	Sensor 3 Temp	°C	#. #	52	
V1.21.11	Encoder 2 Frequency	Hz	#. ##	53	
V1.21.12	Absolute encoder position		#	54	
V1.21.13	Absolute encod. rotations		#	55	
V1.21.14	ID Run Status		#	49	
V1.21.15	PolePairNumber		#	58	
V1.21.16	Analogue input 1	%	#. ##	59	
V1.21.17	Analogue input 2	%	#. ##	60	
V1.21.18 *	Analogue input 3	%	#. ##	61	
V1.21.19 *	Analogue input 4	%	#. ##	62	
V1.21.20	Analogue output 2	%	#. ##	31	
V1.21.21	Analogue output 3	%	#. ##	32	
V1.21.22	Final Frequency Reference Closed Loop	Hz	#. ##	1131	
V1.21.23	Step Response	Hz	#. ###	1132	
V1.21.24	Output power	kW	Varies	1508	
V1.21.25	Sensor 4 Temp	°C	#. #	69	
V1.21.26	Sensor 5 Temp	°C	#. #	70	
V1.21.27	Sensor 6 Temp	°C	#. #	71	
V1.22.1 *	Fieldbus control word			1160	
V1.22.2 *	Fieldbus speed reference	%	#. ##	875	
V1.22.3 *	Fieldbus actual speed	%	#. ##	865	
V1.22.4 *	FB torque reference	%	#. #	1140	
V1.22.5	FB limit scaling	%	#. ##	46	

Table 45: Monitoring values, NXP drives

Index	Monitoring value	Unit	Form	ID	Description
V1.22.6	FB adjust reference	%	###	47	
V1.22.7	FB analogue output	%	###	48	
V1.22.8	Last Active Fault		#	37	
V1.22.9	Motor Current to FB	A	##	45	
V1.22.10	DIN StatusWord 1			56	See Table 47 Digital input statuses: ID56 and ID57
V1.22.11	DIN StatusWord 2			57	See Table 47 Digital input statuses: ID56 and ID57
V1.22.12	Warning			74	
V1.22.13	Fault Word1			1172	See Table 48 Fault Word 1, ID1172
V1.22.14	Fault Word2			1173	See Table 49 Fault Word 2, ID1173
V1.22.15	Alarm Word1			1174	See Table 50 Alarm Word 1, ID1174
V1.22.16.1	Fieldbus process data in 1			221	
V1.22.16.2	Fieldbus process data in 2			222	
V1.22.16.3	Fieldbus process data in 3			223	
V1.22.16.4	Fieldbus process data in 4			224	
V1.22.16.5	Fieldbus process data in 5			225	
V1.22.16.6	Fieldbus process data in 6			226	
V1.22.16.7	Fieldbus process data in 7			227	
V1.22.16.8	Fieldbus process data in 8			228	
V1.22.16.9 **	Fieldbus process data in 9			229	
V1.22.16.10 **	Fieldbus process data in 10			230	
V1.22.16.11 **	Fieldbus process data in 11			231	

Table 45: Monitoring values, NXP drives

Index	Monitoring value	Unit	Form	ID	Description
V1.22.16.12 **	Fieldbus process data in 12			232	
V1.22.16.13 **	Fieldbus process data in 13			233	
V1.22.16.14 **	Fieldbus process data in 14			234	
V1.22.16.15 **	Fieldbus process data in 15			235	
V1.22.16.16 **	Fieldbus process data in 16			236	
V1.22.16.17	Fieldbus process data out 1			237	
V1.22.16.18	Fieldbus process data out 2			238	
V1.22.16.19	Fieldbus process data out 3			239	
V1.22.16.20	Fieldbus process data out 4			240	
V1.22.16.21	Fieldbus process data out 5			241	
V1.22.16.22	Fieldbus process data out 6			242	
V1.22.16.23	Fieldbus process data out 7			243	
V1.22.16.24	Fieldbus process data out 8			244	
V1.22.16.25 **	Fieldbus process data out 9			245	
V1.22.16.26 **	Fieldbus process data out 10			246	
V1.22.16.27 **	Fieldbus process data out 11			247	
V1.22.16.28 **	Fieldbus process data out 12			248	
V1.22.16.29 **	Fieldbus process data out 13			249	

Table 45: Monitoring values, NXP drives

Index	Monitoring value	Unit	Form	ID	Description
V1.22.16.30 **	Fieldbus process data out 14			250	
V1.22.16.31 **	Fieldbus process data out 15			251	
V1.22.16.32 **	Fieldbus process data out 16			252	
V1.23.1	SystemBus System Status			1601	See Table 51 SystemBus Status Word, ID1601
V1.23.2	Total current	A	Varies	83	
V1.23.3.1	Motor current D1	A	Varies	1616	
V1.23.3.2	Motor current D2	A	Varies	1605	
V1.23.3.3	Motor current D3	A	Varies	1606	
V1.23.3.4	Motor current D4	A	Varies	1607	
V1.23.4.1	StatusWord D1			1615	See Table 52 Follower drive Status Word
V1.23.4.2	StatusWord D2			1602	See Table 52 Follower drive Status Word
V1.23.4.3	StatusWord D3			1603	See Table 52 Follower drive Status Word
V1.23.4.4	StatusWord D4			1604	See Table 52 Follower drive Status Word

**] Visible only when the option board installed in the AC drive supports 16 Process data items.

Table 46: Digital input statuses: ID15 and ID16

	DIN1/DIN2/DIN3 status	DIN4/DIN5/DIN6 status
b0	DIN3	DIN6
b1	DIN2	DIN5
b2	DIN1	DIN4

Table 47: Digital input statuses: ID56 and ID57

	DIN StatusWord 1	DIN StatusWord 2
b0	DIN: A.1	DIN: C.5
b1	DIN: A.2	DIN: C.6
b2	DIN: A.3	DIN: D.1
b3	DIN: A.4	DIN: D.2
b4	DIN: A.5	DIN: D.3
b5	DIN: A.6	DIN: D.4
b6	DIN: B.1	DIN: D.5
b7	DIN: B.2	DIN: D.6
b8	DIN: B.3	DIN: E.1
b9	DIN: B.4	DIN: E.2
b10	DIN: B.5	DIN: E.3
b11	DIN: B.6	DIN: E.4
b12	DIN: C.1	DIN: E.5
b13	DIN: C.2	DIN: E.6
b14	DIN: C.3	
b15	DIN: C.4	

Table 48: Fault Word 1, ID1172

	Fault	Comment
b0	Overcurrent or IGBT	F1, F31, F41
b1	Overvoltage	F2
b2	Undervoltage	F9
b3	Motor stalled	F15
b4	Earth fault	F3
b5	Motor underload	F17
b6	Drive overtemperature	F14
b7	Motor overtemperature	F16, F56, F29, F65
b8	Input phase	F10
b11	Keypad or PC control	F52
b12	Fieldbus	F53
b13	SystemBus	F59
b14	Slot	F54
b15	4 mA	F50

Table 49: Fault Word 2, ID1173

	Fault	Comment
b2	Encoder	F43
b4		
b6	External	F51
b9	IGBT	F31, F41
b10	Brake	F58
b14	Main switch open	F64
b15		

Table 50: Alarm Word 1, ID1174

	Warning	Comment
b0	Motor stalled	W15
b1	Motor overtemperature	W16, W29, W56, W65
b2	Motor underload	W17
b3	Input phase loss	W10
b4	Output phase loss	W11
b8	Drive overtemperature warning	W14
b9	Analogue input < 4mA	W50
b10	Not used	
b13	Not used	
b14	Mechanical brake	W58
b15	Keypad or PC Fault/Warning	W52

Table 51: SystemBus Status Word, ID1601

	False	True
b0		Reserved
b1		Drive 1 Ready
b2		Drive 1 Running
b3		Drive 1 Fault
b4		Reserved
b5		Drive 2 Ready
b6		Drive 2 Running
b7		Drive 2 Fault
b8		Reserved
b9		Drive 3 Ready
b10		Drive 3 Running
b11		Drive 3 Fault
b12		Reserved
b13		Drive 4 Ready
b14		Drive 4 Running
b15		Drive 4 Fault

Table 52: Follower drive Status Word

	False	True
b0	Flux not ready	Flux ready (>90 %)
b1	Not in Ready state	Ready
b2	Not running	Running
b3	No fault	Fault
b4		Charge switch state
b5		
b6	Run disabled	Run enable
b7	No warning	Warning
b8		
b9		
b10		
b11	No DC brake	DC brake is active
b12	No run request	Run request
b13	No limit controls active	Limit control active
b14	External brake control OFF	External brake control ON
b15		Heartbeat

Application Status Word combines different drive statuses to one data word (see Monitoring Value V1.21.4 Status Word). Status Word is visible on keypad in Multi-Purpose application only. The Status Word of any other application can be read with the NCDrive PC software.

Table 53: Application Status word content

Application	Standard	Loc/Rem	Multi-Step	PID	MP	PFC
Status Word						
b0						
b1	Ready	Ready	Ready	Ready	Ready	Ready
b2	Run	Run	Run	Run	Run	Run
b3	Fault	Fault	Fault	Fault	Fault	Fault
b4						
b5					No EMStop (NXP)	
b6	Run Enable	Run Enable	Run Enable	Run Enable	Run Enable	Run Enable
b7	Warning	Warning	Warning	Warning	Warning	Warning
b8						
b9						
b10						
b11	DC Brake	DC Brake	DC Brake	DC Brake	DC Brake	DC Brake
b12	Run request	Run request	Run request	Run request	Run request	Run request
b13	Limit control	Limit control	Limit control	Limit control	Limit control	Limit control
b14					Brake control	Aux 1
b15		Place B is active		PID active		Aux 2

6.4.2 BASIC PARAMETERS (CONTROL KEYPAD: MENU M2 -> G2.1)

Table 54: Basic parameters G2.1

Index	Parameter	Min	Max	Unit	Default	Cust	ID	Description
P2.1.1	Min frequency	0.00	P2.1.2	Hz	0.00		101	
P2.1.2	Max frequency	P2.1.1	320.00	Hz	50.00		102	
P2.1.3	Acceleration time 1	0.1	3000.0	s	3.0		103	
P2.1.4	Deceleration time 1	0.1	3000.0	s	3.0		104	
P2.1.5	Current limit	Varies	Varies	A	0.00		107	
P2.1.6 *	Nominal voltage of the motor	180	690	V	NX2: 230V NX5: 400V NX6: 690V		110	
P2.1.7 *	Nominal frequency of the motor	8.00	320.00	Hz	50.00		111	
P2.1.8 *	Nominal speed of the motor	24	20 000	rpm	1440		112	
P2.1.9 *	Nominal current of the motor	Varies	Varies	A	5.40		113	
P2.1.10	Motor cos phi	0.30	1.00		0.85		120	

Table 54: Basic parameters G2.1

Index	Parameter	Min	Max	Unit	Default	Cust	ID	Description
P2.1.11	I/O reference	0	15/16		0		117	0 = AI1 1 = AI2 2 = AI1+AI2 3 = AI1-AI2 4 = AI2-AI1 5 = AI1xAI2 6 = AI1 Joystick 7 = AI2 Joystick 8 = Keypad 9 = Fieldbus 10 = Motor potentiometer 11 = AI1, AI2 minimum 12 = AI1, AI2 maximum 13 = Max frequency 14 = AI1/AI2 selection 15 = Encoder 1 16 = Encoder 2 (NXP only)
P2.1.12	Keypad control reference	0	9		8		121	0 = AI1 1 = AI2 2 = AI1+AI2 3 = AI1-AI2 4 = AI2-AI1 5 = AI1xAI2 6 = AI1 Joystick 7 = AI2 Joystick 8 = Keypad 9 = Fieldbus
P2.1.13	Fieldbus control reference	0	9		9		122	See P2.1.12
P2.1.14	Jogging speed reference	0.00	P2.1.2	Hz	5.00		124	See ID413 in Chapter 9 Parameter descriptions.
P2.1.15	Preset speed 1	0.00	P2.1.2	Hz	10.00		105	
P2.1.16	Preset speed 2	0.00	P2.1.2	Hz	15.00		106	
P2.1.17	Preset speed 3	0.00	P2.1.2	Hz	20.00		126	
P2.1.18	Preset speed 4	0.00	P2.1.2	Hz	25.00		127	
P2.1.19	Preset speed 5	0.00	P2.1.2	Hz	30.00		128	
P2.1.20	Preset speed 6	0.00	P2.1.2	Hz	40.00		129	
P2.1.21	Preset speed 7	0.00	P2.1.2	Hz	50.00		130	

* = Parameter value can only be changed after the FC has been stopped.

6.4.3 INPUT SIGNALS

Table 55: Basic Settings (Control keypad: Menu M2 -> G2.2.1)

Index	Parameter	Min	Max	Unit	Default	Cust	ID	Description
P2.2.1.1 **	Start/Stop logic selection	0	7		0		300	<p>Logic = 0 Ctrl sgn 1 = Start forward Ctrl sgn 2 = Start reverse</p> <p>Logic = 1 Ctrl sgn 1 = Start/Stop Ctrl sgn 2 = Reverse</p> <p>Logic = 2 Ctrl sgn 1 = Start/Stop Ctrl sgn 2 = Run enable</p> <p>Logic = 3 Ctrl sgn 1 = Start pulse (edge) Ctrl sgn 2 = Stop pulse</p> <p>Logic = 4 Ctrl sgn 1 = Start Ctrl sgn 2 = Motor potentiometer UP</p> <p>Logic = 5 Ctrl sgn 1 = Forward pulse (edge) Ctrl sgn 2 = Reverse pulse (edge)</p> <p>Logic = 6 Ctrl sgn 1 = Start pulse (edge) Ctrl sgn 2 = Reverse pulse</p> <p>Logic = 7 Ctrl sgn 1 = Start pulse (edge) Ctrl sgn 2 = Enable pulse</p>
P2.2.1.2 **	Motor potentiometer ramp time	0.1	2000.0	Hz/s	10.0		331	
P2.2.1.3 **	Motor potentiometer frequency reference memory reset	0	2		1		367	<p>0 = No reset 1 = Reset if stopped or powered down 2 = Reset if powered down</p>

Table 55: Basic Settings (Control keypad: Menu M2 -> G2.2.1)

Index	Parameter	Min	Max	Unit	Default	Cust	ID	Description
P. 2.2.1.4 **	Adjust input	0	5		0		493	0 = Not used 1 = AI1 2 = AI2 3 = AI3 4 = AI4 5 = Fieldbus (see group G2.9)
P2.2.1.5	Adjust minimum	0.0	100.0	%	0.0		494	
P2.2.1.6	Adjust maximum	0.0	100.0	%	0.0		495	

** = Parameter value can only be changed after the FC has been stopped.

Table 56: Analogue input 1 (Control keypad: Menu M2 -> G2.2.2)

Index	Parameter	Min	Max	Unit	Default	Cust	ID	Description
P2.2.2.1 **	AI1 signal selection	0.1	E.10		A.1		377	
P2.2.2.2	AI1 filter time	0.00	320.00	s	0.10		324	
P2.2.2.3	AI1 signal range	0	3		0		320	0 = 0-10 V (0-20 mA*) 1 = 2-10 V (4-20 mA*) 2 = -10V...+10 V* 3 = Custom range *
P2.2.2.4	AI1 custom minimum setting	-160.00	160.00	%	0.00		321	
P2.2.2.5	AI1 custom maximum setting	-160.00	160.00	%	100.00		322	
P2.2.2.6	AI1 reference scaling, minimum value	0.00	320.00	Hz	0.00		303	
P2.2.2.7	AI1 reference scaling, maximum value	0.00	320.00	Hz	0.00		304	
P2.2.2.8	AI1 joystick hysteresis	0.00	20.00	%	0.00		384	
P2.2.2.9	AI1 sleep limit	0.00	100.00	%	0.00		385	
P2.2.2.10	AI1 sleep delay	0.00	320.00	s	0.00		386	
P2.2.2.11	AI1 joystick offset	-100.00	100.00	%	0.00		165	

* = Remember to place jumpers of block X2 accordingly. See the product's User Manual.

** = Apply the Terminal to Function method (TTF) to these parameters (see Chapter 9.9 "Terminal to function" (TTF) programming principle)

Table 57: Analogue input 2 (Control keypad: Menu M2 -> G2.2.3)

Index	Parameter	Min	Max	Unit	Default	Cust	ID	Description
P2.2.3.1 **	AI2 signal selection	0.1	E.10		A.2		388	
P2.2.3.2	AI2 filter time	0.00	320.00	s	0.10		329	0 = No filtering
P2.2.3.3	AI2 signal range	0	3		1		325	0 = 0-10 V (0-20mA*) 1 = 2-10 V (4-20 mA*) 2 = -10V...+10 V* 3 = Custom range *
P2.2.3.4	AI2 custom minimum setting	-160.00	160.00	%	20.00		326	
P2.2.3.5	AI2 custom maximum setting	-160.00	160.00	%	100.00		327	
P2.2.3.6	AI2 reference scaling, minimum value	0.00	320.00	Hz	0.00		393	
P2.2.3.7	AI2 reference scaling, maximum value	0.00	320.00	Hz	0.00		394	
P2.2.3.8	AI2 joystick hysteresis	0.00	20.00	%	0.00		395	
P2.2.3.9	AI2 sleep limit	0.00	100.00	%	0.00		396	
P2.2.3.10	AI2 sleep delay	0.00	320.00	s	0.00		397	
P2.2.3.11	AI2 joystick offset	-100.00	100.00	%	0.00		166	

* = Remember to place jumpers of block X2 accordingly. See the product's User Manual.

** = Apply the Terminal to Function method (TTF) to these parameters (see Chapter 9.9 "Terminal to function" (TTF) programming principle)

Table 58: Analogue input 3 (Control keypad: Menu M2 -> G2.2.4)

Index	Parameter	Min	Max	Unit	Default	Cust	ID	Description
P2.2.4.1 **	AI3 signal selection	0.1	E.10		0.1		141	
P2.2.4.2	AI3 filter time	0.00	320.00	s	0.00		142	0 = No filtering
P2.2.4.3	AI3 signal range	0	3		0		143	0 = 0-10 V (0-20mA*) 1 = 2-10 V (4-20 mA*) 2 = -10V...+10 V* 3 = Custom range *
P2.2.4.4	AI3 custom minimum setting	-160.00	160.00	%	0.00		144	
P2.2.4.5	AI3 custom maximum setting	-160.00	160.00	%	100.00		145	
P2.2.4.6	AI3 signal inversion	0	1		0		151	0 = Not inverted 1 = Inverted

* = Remember to place jumpers of block X2 accordingly. See the product's User Manual.

** = Apply the Terminal to Function method (TTF) to these parameters (see Chapter 9.9 "Terminal to function" (TTF) programming principle)

Table 59: Analogue input 4 (Control keypad: Menu M2 -> G2.2.5)

Index	Parameter	Min	Max	Unit	Default	Cust	ID	Description
P2.2.5.1 **	AI4 signal selection	0.1	E.10		0.1		152	
P2.2.5.2	AI4 filter time	0.00	320.00	s	0.00		153	0 = No filtering
P2.2.5.3	AI4 signal range	0	3		1		154	0 = 0-10 V (0-20mA*) 1 = 2-10 V (4-20 mA*) 2 = -10V...+10 V* 3 = Custom range *
P2.2.5.4	AI4 custom minimum setting	-160.00	160.00	%	20.00		155	
P2.2.5.5	AI4 custom maximum setting	-160.00	160.00	%	100.00		156	
P2.2.5.6	AI4 signal inversion	0	1		0		162	0 = Not inverted 1 = Inverted

* = Remember to place jumpers of block X2 accordingly. See the product's User Manual.

** = Apply the Terminal to Function method (TTF) to these parameters (see Chapter 9.9 "Terminal to function" (TTF) programming principle)

Table 60: Free analogue input, signal selection (Keypad: Menu M2 -> G2.2.6)

Index	Parameter	Min	Max	Unit	Default	Cust	ID	Description
P2.2.6.1	Scaling of current limit	0	5		0		399	0 = Not used 1 = AI1 2 = AI2 3 = AI3 4 = AI4 5 = FB Limit Scaling See group G2.9
P2.2.6.2	Scaling of DC-braking current	0	5		0		400	As parameter P2.2.6.1 Scaling from 0 to ID507.
P2.2.6.3	Scaling of acc./dec. times	0	5		0		401	As parameter P2.2.6.1 Scales active ramp from 100 % to 10 %.
P2.2.6.4	Scaling of torque supervision limit	0	5		0		402	As parameter P2.2.6.1 Scaling from 0 to ID348.
P2.2.6.5	Scaling of torque limit	0	5		0		485	As parameter P2.2.6.1 Scaling from 0 to (ID609 (NXS) or ID1287 (NXP)).
NXP drives only								
P2.2.6.6	Scaling of generator torque limit	0	5		0		1087	As parameter P2.2.6.1 Scaling from 0 to ID1288.
P2.2.6.7	Scaling of motor-ing power limit	0	5		0		179	As parameter P2.2.6.1 Scaling from 0 to ID1289.
P2.2.6.8	Scaling of generator power limit	0	5		0		1088	As parameter P2.2.6.1 Scaling from 0 to ID1290.

Use TTF programming method for all Digital inputs parameters. See Chapter 9.9 "Terminal to function" (TTF) programming principle

Table 61: Digital inputs (Control keypad: Menu M2 -> G2.2.4)

Index	Parameter	Min	Default	Cust	ID	Description
P2.2.7.1 *	Start signal 1	0.1	A.1		403	See P2.2.1.1.
P2.2.7.2 *	Start signal 2	0.1	A.2		404	See P2.2.1.1.
P2.2.7.3 *	Run enable	0.1	0.2		407	
P2.2.7.4 *	Reverse	0.1	0.1		412	
P2.2.7.5 *	Preset speed 1	0.1	0.1		419	See preset speeds in Basic Parameters (G2.1).
P2.2.7.6 *	Preset speed 2	0.1	0.1		420	
P2.2.7.7 *	Preset speed 3	0.1	0.1		421	
P2.2.7.8 *	Motor potentiometer reference DOWN	0.1	0.1		417	
P2.2.7.9 *	Motor potentiometer reference UP	0.1	0.1		418	
P2.2.7.10 *	Fault reset	0.1	A.3		414	
P2.2.7.11 *	External fault (close)	0.1	A.5		405	
P2.2.7.12 *	External fault (open)	0.1	0.2		406	
P2.2.7.13 *	Acc/Dec time selection	0.1	A.6		408	
P2.2.7.14 *	Acc/Dec prohibit	0.1	0.1		415	
P2.2.7.15 *	DC braking	0.1	0.1		416	
P2.2.7.16 *	Jogging speed	0.1	A.4		413	
P2.2.7.17 *	AI1/AI2 selection	0.1	0.1		422	
P2.2.7.18 *	Control from I/O terminal	0.1	0.1		409	
P2.2.7.19 *	Control from keypad	0.1	0.1		410	
P2.2.7.20 *	Control from fieldbus	0.1	0.1		411	
P2.2.7.21 *	Parameter set 1/set 2 selection	0.1	0.1		496	
P2.2.7.22 *	Motor control mode 1/2	0.1	0.1		164	
NXP drives only						
P2.2.7.23 *	Cooling monitor	0.1	0.2		750	
P2.2.7.24 *	External brake acknowledge	0.1	0.2		1210	

Table 61: Digital inputs (Control keypad: Menu M2 -> G2.2.4)

Index	Parameter	Min	Default	Cust	ID	Description
P2.2.7.26 *	Enable inching	0.1	0.1		532	
P2.2.7.27 *	Inching reference 1	0.1	0.1		530	
P2.2.7.28 *	Inching reference 2	0.1	0.1		531	
P2.2.7.29 *	Reset encoder counter	0.1	0.1		1090	
P2.2.7.30 *	Emergency stop	0.1	0.2		1213	
P2.2.7.31 *	Master Follower mode 2	0.1	0.1		1092	See Chapter 9.2 Master/follower function (NXP only) and parameters P2.11.1-P2.11.7.
P2.2.7.32 *	Input switch acknowledgement	0.1	0.2		1209	
P2.2.7.33 *	Active filter fault input	0.1	0.1		214	

cc = closing contact

oc = opening contact

* = Apply the Terminal to Function method (TTF) to these parameters (see Chapter 9.9 "Terminal to function" (TTF) programming principle).

6.4.4 OUTPUT SIGNALS

Table 62: Delayed digital output 1 (Keypad: Menu M2 -> G2.3.1)

Index	Parameter	Min	Max	Unit	Default	Cust	ID	Description
P2.3.1.1 *	Digital output 1 signal selection	0.1	E.10		0.1		486	
P2.3.1.2	Digital output 1 function	0	29		1		312	0 = Not used 1 = Ready 2 = Run 3 = Fault 4 = Fault inverted 5 = FC overheat warning 6 = Ext. fault or warning 7 = Ref. fault or warning 8 = Warning 9 = Reverse 10 = Jogging spd selected 11 = At speed 12 = Mot. regulator active 13 = Freq. limit 1 superv. 14 = Freq. limit 2 superv. 15 = Torque limit superv. 16 = Ref. limit supervision 17 = External brake control 18 = I/O control place act. 19 = FC temp. limit superv. 20 = Reference inverted 21 = Ext. brake control inverted

Table 62: Delayed digital output 1 (Keypad: Menu M2 -> G2.3.1)

Index	Parameter	Min	Max	Unit	Default	Cust	ID	Description
P2.3.1.2	Digital output 1 function	0	29		1		312	22 = Therm. fault or warn. 23 = On/Off control 24 = Fieldbus DIN 1 25 = Fieldbus DIN 2 26 = Fieldbus DIN 3 27 = Temp.Warning NXS drives only: 28 = Temp.Fault NXP drives only: 29 = ID.Bit
P2.3.1.3	Digital output 1 on delay	0.00	320.00	s	0.00		487	
P2.3.1.4	Digital output 1 off delay	0.00	320.00	s	0.00		488	
NXP drives only								
P2.3.1.5	INV Delayed DO1	0	1		0		1587	NXS drives only: 0 = No 1 = Yes
P2.3.1.6	ID Bit Free DO1	0.0	200.15		0.0		1217	

* = Use TTF method to program these parameters.

Table 63: Delayed digital output 2 (Keypad: Menu M2 -> G2.3.2)

Index	Parameter	Min	Max	Unit	Default	Cust	ID	Description
P2.3.2.1	Digital output 2 signal selection	0.1	E.10		0.1		489	
P2.3.2.2	Digital output 2 function	0	29		0		490	See P2.3.1.2
P2.3.2.3	Digital output 2 on delay	0.00	320.00	s	0.00		491	
P2.3.2.4	Digital output 2 off delay	0.00	320.00	s	0.00		492	
NXP drives only								
P2.3.2.5	INV Delayed DO1	0	1		0		1588	0 = No 1 = Yes
P2.3.2.6	ID Bit Free DO1	0.0	200.15		0.0		1385	

Table 64: Digital output signals (Control keypad: Menu M2 -> G2.2.4)

Index	Parameter	Min	Default	Cust	ID	Description
P2.3.3.1 *	Ready	0.1	A.1		432	
P2.3.3.2 *	Run	0.1	B.1		433	
P2.3.3.3 *	Fault	0.1	B.2		434	
P2.3.3.4 *	Inverted fault	0.1	0.1		435	
P2.3.3.5 *	Warning	0.1	0.1		436	
P2.3.3.6 *	External fault	0.1	0.1		437	
P2.3.3.7 *	Reference fault/warning	0.1	0.1		438	
P2.3.3.8 *	Overtemperature warning	0.1	0.1		439	
P2.3.3.9 *	Reverse	0.1	0.1		440	
P2.3.3.10 *	Unrequested direction	0.1	0.1		441	
P2.3.3.11 *	At speed	0.1	0.1		442	
P2.3.3.12 *	Jogging speed	0.1	0.1		443	
P2.3.3.13 *	I/O control place	0.1	0.1		444	
P2.3.3.14 *	External brake control	0.1	0.1		445	See IDs 445 and 446 in Chapter 9 <i>Parameter descriptions</i> .
P2.3.3.15 *	External brake control, inverted	0.1	0.1		446	
P2.3.3.16 *	Output frequency limit 1 supervision	0.1	0.1		447	See ID315 in Chapter 9 <i>Parameter descriptions</i> .
P2.3.3.17 *	Output frequency limit 2 supervision	0.1	0.1		448	See ID346 in Chapter 9 <i>Parameter descriptions</i> .
P2.3.3.18 *	Reference limit supervision	0.1	0.1		449	See ID350 in Chapter 9 <i>Parameter descriptions</i> .
P2.3.3.19 *	Temperature limit supervision	0.1	0.1		450	See ID354 in Chapter 9 <i>Parameter descriptions</i> .
P2.3.3.20 *	Torque limit supervision	0.1	0.1		451	See ID348 in Chapter 9 <i>Parameter descriptions</i> .
P2.3.3.21 *	Themistor fault or warning	0.1	0.1		452	
P2.3.3.22 *	Analogue input supervision limit	0.1	0.1		453	See ID356 in Chapter 9 <i>Parameter descriptions</i> .
P2.3.3.23 *	Motor regulator activation	0.1	0.1		454	
P2.3.3.24 *	Fieldbus DIN 1	0.1	0.1		455	

Table 64: Digital output signals (Control keypad: Menu M2 -> G2.2.4)

Index	Parameter	Min	Default	Cust	ID	Description
P2.3.3.25 *	Fieldbus DIN 2	0.1	0.1		456	
P2.3.3.26 *	Fieldbus DIN 3	0.1	0.1		457	
P2.3.3.27 *	Fieldbus DIN 4	0.1	0.1		169	
P2.3.3.28 *	Fieldbus DIN 5	0.1	0.1		170	
NXP drives only						
P2.3.3.29 *	DC ready pulse	0.1	0.1		1218	
P2.3.3.30 *	Safe Disable Active	0.1	0.1		756	

* = Use TTF method to program these parameters.

**CAUTION!**

Be ABSOLUTELY sure not to connect two functions to one and same output in order to avoid function overruns and to ensure flawless operation.

Table 65: Limit settings (Control keypad: Menu M2 -> G2.3.4)

Index	Parameter	Min	Max	Unit	Default	Cust	ID	Description
P2.3.4.1	Output frequency limit 1 supervision	0	3		0		315	0 = No supervision 1 = Low limit supervision 2 = High limit supervision 3 = Brake-on control
P2.3.4.2	Output frequency limit 1; Supervised value	0.00	320.00	Hz	0.00		316	
P2.3.4.3	Output frequency limit 2 supervision	0	4		0		346	0 = No supervision 1 = Low limit supervision 2 = High limit supervision 3 = Brake-off control 4 = Brake on/off control
P2.3.4.4	Output frequency limit 2; Supervised value	0.00	320.00	Hz	0.00		347	
P2.3.4.5	Torque limit supervision	0	3		0		348	0 = No supervision 1 = Low limit supervision 2 = High limit supervision 3 = Brake-off control
P2.3.4.6	Torque limit supervision value	-300.0	300.0	%	100.0		349	
P2.3.4.7	Reference limit supervision	0	2		0		350	0 = No supervision 1 = Low limit 2 = High limit
P2.3.4.8	Reference limit supervision value	0.0	100.0	%	0.0		351	0.0 = Min frequency 100.0 = Max frequency
P2.3.4.9	External brake-off delay	0.0	100.0	s	0.5		352	
P2.3.4.10	External brake-on delay	0.0	100.0	s	1.5		353	

Table 65: Limit settings (Control keypad: Menu M2 -> G2.3.4)

Index	Parameter	Min	Max	Unit	Default	Cust	ID	Description
P2.3.4.11	Temperature limit supervision	0	2		0		354	0 = No supervision 1 = Low limit 2 = High limit
P2.3.4.12	Temperature supervised value	-10	100	°C	40		355	
P2.3.4.13	Analogue supervision signal	0	4		0		356	0 = Not used 1 = AI1 2 = AI2 3 = AI3 4 = AI4
P2.3.4.14	Analogue supervision low limit	0.00	100.00	%	10.00		357	See P2.3.3.22.
P2.3.4.15	Analogue supervision high limit	0.00	100.00	%	90.00		358	See P2.3.3.22.
NXP drives only								
P2.3.4.16	Brake On/Off Current Limit	0	2 x IH	A	0		1085	

Table 66: Analogue output 1 (Control keypad: Menu M2 -> G2.3.5)

Index	Parameter	Min	Max	Unit	Default	Cust	ID	Description
P2.3.5.1 *	Analogue output 1 signal selection	0.1	E.10		A.1		464	
P2.3.5.2	Analogue output 1 function	0	15		1		307	0 = Not used (20 mA / 10 V) 1 = Output freq. (0-fmax) 2 = Freq. reference (0-fmax) 3 = Motor speed (0-Motor nominal speed) 4 = Motor current (0-InMotor) 5 = Motor torque (0-TnMotor) 6 = Motor power (0-PnMotor) 7 = Motor voltage (0-UnMotor) 8 = DC link volt (0-1000V) 9 = AI1 10 = AI2 11 = Output freq. (fmin - fmax) 12 = Motor torque (-2...+2xTNmot) 13 = Motor power (-2...+2xTNmot) 14 = PT100 temperature 15 = FB analogue output Process-Data4 (NXS)
P2.3.5.3	Analogue output 1 filter time	0.00	100.00	s	1.00		308	
P2.3.5.4	Analogue output 1 inversion	0	1		0		309	0 = Not inverted 1 = Inverted
P2.3.5.5	Analogue output 1 minimum	0	1		0		310	0 = 0 mA (0 V) 1 = 4 mA (2 V)
P2.3.5.6	Analogue output 1 scale	10	1000	%	100		311	
P2.3.5.7	Analogue output 1 offset	-100.00	100.00	%	0.00		375	

* = Use TTF method to program these parameters.

Table 67: Analogue output 2 (Control keypad: Menu M2 -> G2.3.6)

Index	Parameter	Min	Max	Unit	Default	Cust	ID	Description
P2.3.6.1 *	Analogue output 2 signal selection	0.1	E.10		0.1		471	
P2.3.6.2	Analogue output 2 function	0	15		4		472	See P2.3.5.2
P2.3.6.3	Analogue output 2 filter time	0.00	10.00	s	1.00		473	
P2.3.6.4	Analogue output 2 inversion	0	1		0		474	0 = Not inverted 1 = Inverted
P2.3.6.5	Analogue output 2 minimum	0	1		0		475	0 = 0 mA (0 V) 1 = 4 mA (2 V)
P2.3.6.6	Analogue output 2 scale	10	1000	%	100		476	
P2.3.6.7	Analogue output 2 offset	-100.00	100.00	%	0.00		477	

* = Use TTF method to program these parameters.

Table 68: Analogue output 3 (Control keypad: Menu M2 -> G2.3.7)

Index	Parameter	Min	Max	Unit	Default	Cust	ID	Description
P2.3.7.1 *	Analogue output 3 signal selection	0.1	E.10		0.1		478	
P2.3.7.2	Analogue output 3 function	0	15		5		479	See P2.3.5.2
P2.3.7.3	Analogue output 3 filter time	0.00	10.00	s	1.00		480	
P2.3.7.4	Analogue output 3 inversion	0	1		0		481	0 = Not inverted 1 = Inverted
P2.3.7.5	Analogue output 3 minimum	0	1		0		482	0 = 0 mA (0 V) 1 = 4 mA (2 V)
P2.3.7.6	Analogue output 3 scale	10	1000	%	100		483	
P2.3.7.7	Analogue output 3 offset	-100.00	100.00	%	0.00		484	

* = Use TTF method to program these parameters.

6.4.5 DRIVE CONTROL PARAMETERS (CONTROL KEYPAD: MENU M2 -> G2.4)

Table 69: Drive control parameters, G2.4

Index	Parameter	Min	Max	Unit	Default	Cust	ID	Description
P2.4.1	Ramp 1 shape	0.0	10.0	s	0.1		500	0 = Linear 100 = Full acc/dec inc/dec times
P2.4.2	Ramp 2 shape	0.0	10.0	s	0.0		501	0 = Linear 100 = Full acc/dec inc/dec times
P2.4.3	Acceleration time 2	0.1	3000.0	s	10.0		502	
P2.4.4	Deceleration time 2	0.1	3000.0	s	10.0		503	
P2.4.5 *	Brake chopper	0	4		0		504	0 = Disabled 1 = Used when running 2 = External brake chopper 3 = Used when stopped/running 4 = used when run- ning (no testing)
P2.4.6	Start function	0	2		0		505	0 = Ramp 1 = Flying start 2 = Conditional fly- ing start
P2.4.7	Stop function	0	3		0		506	0 = Coasting 1 = Ramp 2 = Ramp+Run enable coast 3 = Coast+Run enable ramp
P2.4.8	DC braking cur- rent	0.00	IL	A	0.7 x IH		507	
P2.4.9	DC braking time at stop	0.00	600.00	s	0.00		508	
P2.4.10	Frequency to start DC braking during ramp stop	0.10	10.00	Hz	1.50		515	
P2.4.11	DC braking time at start	0.00	600.00	s	0.00		516	
P2.4.12	Flux brake	0	1		0		520	0 = Off 0 = On

Table 69: Drive control parameters, G2.4

Index	Parameter	Min	Max	Unit	Default	Cust	ID	Description
P2.4.13	Flux braking current	0.00	IL	A	IH		519	
NXP drives only								
P2.4.14	DC-brake current at stop	0	IL	A	0.1 x IH		1080	
P2.4.15	Inching reference 1	-320.00	320.00	Hz	2.00		1239	
P2.4.16	Inching reference 2	-320.00	320.00	Hz	653.36		1240	
P2.4.17	Inching ramp	0.1	3200.0	s	1.0		1257	
P2.4.18	Emergency stop mode	0	1		0		1276	0 = Coasting 1 = Ramp
P2.4.19	Control options	0	65536		0		1084	
P2.4.20	Modulator type	0	1		0		1516	0 = ASIC modulator 1 = Software Modulator 1
P2.4.21	Ramp; Skip S2	0	1		0		1900	

* = Parameter value can only be changed aftr the FC has been stopped.

6.4.6 PROHIBIT FREQUENCY PARAMETERS (CONTROL KEYPAD: MENU M2 -> G2.5)

Table 70: Prohibit frequency parameters, G2.5

Index	Parameter	Min	Max	Unit	Default	Cust	ID	Description
P2.5.1	Prohibit frequency range 1 low limit	-1.00	320.00	Hz	0.00		509	0 = Not used
P2.5.2	Prohibit frequency range 1 high limit	0.00	320.00	Hz	0.00		510	0 = Not used
P2.5.3	Prohibit frequency range 2 low limit	0.00	320.00	Hz	0.00		511	0 = Not used
P2.5.4	Prohibit frequency range 2 high limit	0.00	320.00	Hz	0.00		512	0 = Not used
P2.5.5	Prohibit frequency range 3 low limit	0.00	320.00	Hz	0.00		513	0 = Not used
P2.5.6	Prohibit frequency range 3 high limit	0.00	320.00	Hz	0.00		514	0 = Not used
P2.5.7	Prohibit acc./dec. ramp	0.1	10.0	x	1.0		518	

6.4.7 MOTOR CONTROL PARAMETERS (CONTROL KEYPAD: MENU M2 -> G2.6)

Table 71: Motor control parameters, G2.6

Index	Parameter	Min	Max	Unit	Default	Cust	ID	Description
P2.6.1	Motor control mode	0	2/4		0		600	0 = Frequency control 1 = Speed control 2 = Torque control NXP: 3 = Closed loop speed ctrl 4 = Closed loop torque ctrl
P2.6.2	U/f optimisation	0	1		0		109	NXP: 0 = Not used 1 = Automatic torque boost
P2.6.3	U/f ratio selection	0	3		0		108	NXP: 0 = Linear 1 = Squared 2 = Programmable 3 = Linear with flux optim.
P2.6.4	Field weakening point	8.00	320.00	Hz	50.00		602	
P2.6.5	Voltage at field weakening point	10.00	200.00	%	100.00		603	
P2.6.6	U/f curve midpoint frequency	0.00	P2.6.4	Hz	50.00		604	
P2.6.7	U/f curve midpoint voltage	0.00	100.00	%	100.00		605	
P2.6.8	Output voltage at zero frequency	0.00	40.00	%	Varies		606	
P2.6.9	Switching frequency	1	Varies	kHz	Varies		601	
P2.6.10	Overvoltage controller	0	2		1		607	0 = Not used 1 = Used (no ramping) 2 = Used (ramping)
P2.6.11	Undervoltage controller	0	2		1		608	0 = Not used 1 = Used (no ramping) 2 = Used (ramping to zero)
P2.6.12	Motor control mode 2	0	4		2		521	See P2.6.1

Table 71: Motor control parameters, G2.6

Index	Parameter	Min	Max	Unit	Default	Cust	ID	Description
P2.6.13	Speed controller P gain (open loop)	0	32767		3000		637	
P2.6.14	Speed controller I gain (open loop)	0	32767		300		638	
P2.6.15	Load drooping	0.00	100.00	%	0.00		620	
P2.6.16	Identification	0	1/4		0		631	0 = No action 1 = Identification w/o run NXP: 2 = Identification with run 3 = Encoder ID Run (PMSM) 4 = Ident All
NXP drives only								
P2.6.17	Restart delay	0.100	60000	s	Varies		1424	
P2.6.18	Load drooping time	0	32000	ms	0		656	
P2.6.19	Negative frequency limit	-327.67	P2.6.20	Hz	-327.67		1286	
P2.6.20	Positive frequency limit	P2.6.19	327.67	Hz	327.67		1285	
P2.6.21	Generator torque limit	0.0	300.0	%	300.0		1288	
P2.6.22	Motoring torque limit	0.0	300.0	%	300.0		1287	

* = Parameter value can only be changed after the AC drive has been stopped.

**NOTE!**

Depending on the application version, the parameter code may appear as 2.6.17.xx instead of 2.6.23.xx

Table 72: NXS drives: Closed Loop parameters (Control keypad: Menu M2 ->G2.6.23)

Index	Parameter	Min	Max	Unit	Default	Cust	ID	Description
P2.6.17.1	Magnetizing current	0.00	2 x IH	A	0.00		612	
P2.6.17.2	Speed control P	1	1000		30		613	
P2.6.17.3	Speed control I time	-3200.0	3200.0	ms	100.0		614	
P2.6.17.5	Acceleration compensation	0.00	300.00	s	0.00		626	
P2.6.17.6	Slip adjust	0	500	%	75		619	
P2.6.17.7	Magnetizing current at start	0.00	IL	A	0.00		627	
P2.6.17.8	Magnetizing time at start	0	32000	ms	0		628	
P2.6.17.9	0-speed time at start	0	32000	ms	100		615	
P2.6.17.10	0-speed time at stop	0	32000	ms	100		616	
P2.6.17.11	Start-up torque	0	3		0		621	0 = Not used 1 = Torque memory 2 = Torque reference 3 = Start-up torque fwd/rev
P2.6.17.12	Start-up torque FWD	-300.0	300.0	s	0.0		633	
P2.6.17.13	Start-up torque REV	-300.0	300.0	s	0.0		634	
P2.6.17.15	Encoder filter time	0.0	100.0	ms	0.0		618	
P2.6.17.17	Current control P gain	0.00	100.00	%	40.00		617	

Table 73: NXP drives: Closed Loop parameters (Control keypad: Menu M2 ->G2.6.23)

Index	Parameter	Min	Max	Unit	Default	Cust	ID	Description
P2.6.23.1	Magnetizing current	0.00	2 x IH	A	0.00		612	
P2.6.23.2	Speed control P	1	1000		30		613	
P2.6.23.3	Speed control I time	-32000	3200.0	ms	100.0		614	
P2.6.23.5	Acceleration compensation	0.00	300.00	s	0.00		626	
P2.6.23.6	Slip adjust	0	500	%	75		619	
P2.6.23.7	Magnetizing current at start	0	IL	A	0.00		627	
P2.6.23.8	Magnetizing time at start	0	60000	ms	0		628	
P2.6.23.9	0-speed time at start	0	32000	ms	100		615	
P2.6.23.10	0-speed time at stop	0	32000	ms	100		616	
P2.6.23.11	Start-up torque	0	3		0		621	0 = Not used 1 = Torque memory 2 = Torque reference 3 = Start-up torque fwd/rev
P2.6.23.12	Start-up torque FWD	-300.0	300.0	s	0.0		633	
P2.6.23.13	Start-up torque REV	-300.0	300.0	s	0.0		634	
P2.6.23.15	Encoder filter time	0.0	100.0	ms	0.0		618	
P2.6.23.17	Current control P gain	0.00	320.00	%	40.00		617	
P2.6.23.18	CurrentControl-Time	0.0	3200.0	ms	1.5		657	
P2.6.23.19	Generator power limit	0.0	300.0	%	300.0		1290	
P2.6.23.20	Motoring power limit	0.0	300.0	%	300.0		1289	

Table 73: NXP drives: Closed Loop parameters (Control keypad: Menu M2 ->G2.6.23)

Index	Parameter	Min	Max	Unit	Default	Cust	ID	Description
P2.6.23.21	Negative torque limit	0.0	300.0	%	300.0		645	
P2.6.23.22	Positive torque limit	0.0	300.0	%	300.0		646	
P2.6.23.23	Flux off delay	-1	32000	s	0		1402	
P2.6.23.24	Stop state flux	0.0	150.00	%	100.00		1401	
P2.6.23.25	SPC f1 point	0.00	320.00	Hz	0.00		1301	
P2.6.23.26	SPC f0 point	0.00	320.0	Hz	0.00		1300	
P2.6.23.27	SPC Kp f0	0	1000	%	100		1299	
P2.6.23.28	SPC Kp FWP	0	1000	%	100		1298	
P2.6.23.29	SPC torque minimum	0.0	400.0	%	0.0		1296	
P2.6.23.30	SPC torque minimum Kp	0	1000	%	100		1295	
P2.6.23.31	SPC Kp TC torque	0	1000	ms	0		1297	
P2.6.23.32	Flux reference	0.0	500.0	%	100.0		1250	
P2.6.23.33	Speed error filter TC	0	1000	ms	0		1311	
P2.6.23.34	Modulation limit	0	150	%	100		655	

Table 74: NXP drives: PMS Motor control parameters (Control keypad: Menu M2 -> G2.6.24)

Index	Parameter	Min	Max	Unit	Default	Cust	ID	Description
P2.6.24.1	Motor type	0	1		0		650	0 = Induction Motor 1 = PMS Motor
P2.6.24.2	PMSShaft position	0	65535		0		649	
P2.6.24.3	Start angle ID modified	0	10		0		1691	
P2.6.24.4	Start Angle ID current	0.0	150.0	%	0.0		1756	
P2.6.24.5	Polarity pulse current	-1.0	200.0	%	-1.0		1566	
P2.6.24.6	I/f current	0.0	150.0	%	50.0		1693	
P2.6.24.7	I/f control limit	0.0	300.0	%	10.0		1790	
P2.6.24.8	FluxCurrent Kp	0	32000		500		651	
P2.6.24.9	FluxCurrent Time	0.0	100.0	ms	5.0		652	

Table 75: NXS drives: Identification parameters (Control keypad: Menu M2 -> G2.6.25)

Index	Parameter	Min	Max	Unit	Default	Cust	ID	Description
P2.6.18.1	Speed step	-50.0	50.0	%	0.0		1252	
P2.6.18.2	Torque step	-100.0	300.0	%	0.0		1253	

Table 76: NXP drives: Identification parameters (Control keypad: Menu M2 -> G2.6.25)

Index	Parameter	Min	Max	Unit	Default	Cust	ID	Description
P2.6.25.1	Flux 10 %	0.0	250.0	%	10.0		1355	
P2.6.25.2	Flux 20 %	0.0	250.0	%	20.0		1356	
P2.6.25.3	Flux 30 %	0.0	250.0	%	30.0		1357	
P2.6.25.4	Flux 40 %	0.0	250.0	%	40.0		1358	
P2.6.25.5	Flux 50 %	0.0	250.0	%	50.0		1359	
P2.6.25.6	Flux 60 %	0.0	250.0	%	60.0		1360	
P2.6.25.7	Flux 70 %	0.0	250.0	%	70.0		1361	
P2.6.25.8	Flux 80 %	0.0	250.0	%	80.0		1362	
P2.6.25.9	Flux 90 %	0.0	250.0	%	90.0		1363	
P2.6.25.10	Flux 100 %	0.0	250.0	%	100.0		1364	
P2.6.25.11	Flux 110 %	0.0	250.0	%	110.0		1365	
P2.6.25.12	Flux 120 %	0.0	250.0	%	120.0		1366	
P2.6.25.13	Flux 130 %	0.0	250.0	%	130.0		1367	
P2.6.25.14	Flux 140 %	0.0	250.0	%	140.0		1368	
P2.6.25.15	Flux 150 %	0.0	250.0	%	150.0		1369	
P2.6.25.16	Rs voltage drop	0	30000		Varies		662	
P2.6.25.17	Ir add zero point voltage	0	30000		Varies		664	
P2.6.25.18	Ir add generator scale	0	30000		Varies		665	
P2.6.25.19	Ir add motoring scale	0	30000		Varies		667	
P2.6.25.20	MotorBEM Voltage	0.00	320.00	%	90.0		674	
P2.6.25.21	Ls voltage drop	0	3000		512		673	
P2.6.25.22	Iu Offset	-32000	32000		10000		668	
P2.6.25.23	Iv Offset	-32000	32000		0		669	
P2.6.25.24	Iw Offset	-32000	32000		0		670	
P2.6.25.25	Speed step	-50.0	50.0	%	0.0		1252	

Table 76: NXP drives: Identification parameters (Control keypad: Menu M2 -> G2.6.25)

Index	Parameter	Min	Max	Unit	Default	Cust	ID	Description
P2.6.25.26	Torque step	-100.0	100.0	%	0.0		1253	

Table 77: Stabilators

Index	Parameter	Min	Max	Unit	Default	Cust	ID	Description
P2.6.26.1	Torque stabilator gain	0	1000		100		1412	
P2.6.26.2	Torque stabilator damping	0	1000		900		1413	
P2.6.26.3	Torque stabilator gain FWP	0	1000		50		1414	
P2.6.26.4	Torque stabilator limit ratio	0	20.00	%	3.00		1720	
P2.6.26.5	Flux circle stabilator gain	0	32767		10000		1550	
P2.6.26.6	Flux stabilator TC	0	32700		900		1551	
P2.6.26.7	Flux stabilator gain	0	32000		500		1797	
P2.6.26.8	Flux stabilator coefficient	-30000	32766		64		1796	
P2.6.26.9	Voltage stabilator gain	0	100.0	%	10.0		1738	
P2.6.26.10	Voltage stabilator TC	0	1000		900		1552	
P2.6.26.11	Voltage stabilator limit	0	32000	Hz	1.50		1553	

6.4.8 PROTECTIONS (CONTROL KEYPAD: MENU M2 -> G2.7)

Table 78: Protections, G2.7

Index	Parameter	Min	Max	Unit	Default	Cust	ID	Description
P2.7.1	Response to 4 mA reference fault	0	5		0		700	0 = No response 1 = Warning 2 = Warning+Previous Freq. 3 = Wrng+Preset-Freq 2.7.2 4 = Fault, stop acc. to 2.4.7 5 = Fault, stop by coasting
P2.7.2	4 mA reference fault frequency	0.00	P2.1.2	Hz	0.00		728	
P2.7.3	Response to external fault	0	3		2		701	0 = No response 1 = Warning 2 = Fault, stop acc. to 2.4.7
P2.7.4	Input phase supervision	0	3		3		730	3 = Fault, stop by coasting
P2.7.5	Response to undervoltage fault	0	1		0		727	0 = Fault stored in history Fault not stored
P2.7.6	Output phase supervision	0	3		2		702	0 = No response 1 = Warning 2 = Fault, stop acc. to 2.4.7
P2.7.7	Earth fault protection	0	3		2		703	3 = Fault, stop by coasting
P2.7.8	Thermal protection of the motor	0	3		2		704	
P2.7.9	Motor ambient temperature factor	-100.0	100.0	%	0.0		705	
P2.7.10	Motor cooling factor at zero speed	0.0	150.0	%	40.0		706	
P2.7.11	Motor thermal time constant	1	200	min	Varies		707	
P2.7.12	Motor duty cycle	0	150	%	100		708	
P2.7.13	Stall protection	0	3		0		709	0 = No response 1 = Warning 2 = Fault, stop acc. to 2.4.7 3 = Fault, stop by coasting

Table 78: Protections, G2.7

Index	Parameter	Min	Max	Unit	Default	Cust	ID	Description
P2.7.14	Stall current	0.00	P2.1.2	A	1H		710	
P2.7.15	Stall time limit	1.00	120.00	s	15.00		711	
P2.7.16	Stall frequency limit	1.0	P2.1.2	Hz	25.0		712	
P2.7.17	Underload protection	0	3		0		713	0 = No response 1 = Warning 2 = Fault, stop acc. to 2.4.7 3 = Fault, stop by coasting
P2.7.18	Field weakening area load	10.0	150.0	%	50.0		714	
P2.7.19	Zero frequency load	5.0	150.0	%	10.0		715	
P2.7.20	Underload protection time limit	2.00	600.00	s	20.00		716	
P2.7.21	Response to thermistor fault	0	3		2		732	0 = No response 1 = Warning 2 = Fault, stop acc. to 2.4.7 3 = Fault, stop by coasting
P2.7.22	Response to field-bus fault	0	4		2		733	0 = No response 1 = Warning 2 = Fault, stop acc. to 2.4.7 3 = Fault, stop by coasting 4 = Warning, set frequency reference to FB Fault Frequency (P2.7.40) (NXP drives only)
P2.7.23	Response to slot fault	0	3		2		734	See P2.7.21
P2.7.24	TBoard1 Numbers	0	5		0		739	0 = Not used 1 = Channel 1 2 = Channel 1 & 2 3 = Channel 1 & 2 & 3 4 = Channel 2 & 3 5 = Channel 3

Table 78: Protections, G2.7

Index	Parameter	Min	Max	Unit	Default	Cust	ID	Description
P2.7.25	TBoard Flt. Resp	0	3		0		740	0 = No response 1 = Warning 2 = Fault, stop acc. to 2.4.7 3 = Fault, stop by coasting
P2.7.26	TBoard1 Warn.Lim	-30.0	200.0	°C	120.0		741	
P2.7.27	TBoard1 Flt.Lim	-30.0	200.0	°C	130.0		742	
NXP drives only								
P2.7.28	Brake fault action	1	3		1		1316	1 = Warning 2 = Fault, stop acc. to 2.4.7 3 = Fault, stop by coasting
P2.7.29	Brake fault delay	0.00	320.00	s	0.20		1317	
P2.7.30	System bus fault	3	3		3		1082	0 = No response 1 = Warning 2 = Fault, stop acc. to 2.4.7 3 = Fault, stop by coasting
P2.7.31	System bus fault delay	0.00	10.00	s	3.00		1352	
P2.7.32	Cooling fault delay	0.00	7.00	s	2.00		751	
P2.7.33	Speed error mode	0	2		0		752	0 = No response 1 = Warning 2 = Fault, stop by coasting
P2.7.34	Speed error maximum difference	0	100	%	5		753	
P2.7.35	Speed error fault delay	0.00	100.0	s	0.50		754	
P2.7.36	Safe disable mode	0	2		1		755	1 = Warning, stop by coasting 2 = Fault, stop by coasting
NXP and NXS drives								

Table 78: Protections, G2.7

Index	Parameter	Min	Max	Unit	Default	Cust	ID	Description
P2.7.37	TBoard2 Numbers	0	5		0		743	0 = Not used 1 = Channel 1 2 = Channel 1 & 2 3 = Channel 1 & 2 & 3 4 = Channel 2 & 3 5 = Channel 3
P2.7.38	TBoard2 Warn.Lim	-30.0	200.0	C°	120		745	
P2.7.39	TBoard2 Flt.Lim	-30.0	200.0	C°	130		746	
NXP drives only								
P2.7.40	FB Fault Freq	0	P2.1.2	Hz	20.00		1801	
P2.7.41	ActiveFilt.Fault	0	3		2		776	0=No response 1 = Warning 2 = Fault, stop acc. to P2.4.7 3=Fault, stop by coasting

6.4.9 AUTORESTART PARAMETERS (CONTROL KEYPAD: MENU M2 -> G2.8)

Table 79: Autorestart parameters, G2.8

Index	Parameter	Min	Max	Unit	Default	Cust	ID	Description
P2.8.1	Wait time	0.10	10.00	s	0.50		717	
P2.8.2	Trial time	0.00	60.00	s	30.00		718	
P2.8.3	Start function	0	2		0		719	0 = Ramp 1 = Flying start 2 = According to P2.4.6
P2.8.4	Number of tries after undervoltage trip	0	10		0		720	
P2.8.5	Number of tries after overvoltage trip	0	10		0		721	
P2.8.6	Number of tries after overcurrent trip	0	3		0		722	
P2.8.7	Number of tries after 4mA reference trip	0	10		0		723	
P2.8.8	Number of tries after motor temperature fault trip	0	10		0		726	
P2.8.9	Number of tries after external fault trip	0	10		0		725	
P2.8.10	Number of tries after underload fault trip	0	10		0		738	

6.4.10 FIELDBUS PARAMETERS (CONTROL KEYPAD: MENU M2 ->G2.9)

Table 80: Fieldbus parameters

Index	Parameter	Min	Max	Unit	Default	Cust	ID	Description
P2.9.1	Fieldbus min scale	0.00	320.00	Hz	0.00		850	
P2.9.2	Fieldbus max scale	0.00	320.00	Hz	0.00		851	
P2.9.3	Fieldbus process data out 1 selection	0	10000		1		852	
P2.9.4	Fieldbus process data out 2 selection	0	10000		2		853	
P2.9.5	Fieldbus process data out 3 selection	0	10000		45		854	
P2.9.6	Fieldbus process data out 4 selection	0	10000		4		855	
P2.9.7	Fieldbus process data out 5 selection	0	10000		5		856	
P2.9.8	Fieldbus process data out 6 selection	0	10000		6		857	
P2.9.9	Fieldbus process data out 7 selection	0	10000		7		858	
P2.9.10	Fieldbus process data out 8 selection	0	10000		37		859	
P2.9.11 *	Fieldbus process data out 9 selection	0	10000		0		558	
P2.9.12 *	Fieldbus process data out 10 selection	0	10000		0		559	
P2.9.13 *	Fieldbus process data out 11 selection	0	10000		0		560	
P2.9.14 *	Fieldbus process data out 12 selection	0	10000		0		561	

Table 80: Fieldbus parameters

Index	Parameter	Min	Max	Unit	Default	Cust	ID	Description
P2.9.15 *	Fieldbus process data out 13 selection	0	10000		0		562	
P2.9.16 *	Fieldbus process data out 14 selection	0	10000		0		563	
P2.9.17 *	Fieldbus process data out 15 selection	0	10000		0		564	
P2.9.18 *	Fieldbus process data out 16 selection	0	10000		0		565	
NXP drives only (In NXS, default values are not editable)								
P2.9.19	Fieldbus process data in 1 selection	0	10000		1140		876	
P2.9.20	Fieldbus process data in 2 selection	0	10000		46		877	
P2.9.21	Fieldbus process data in 3 selection	0	10000		47		878	
P2.9.22	Fieldbus process data in 4 selection	0	10000		48		879	
P2.9.23	Fieldbus process data in 5 selection	0	10000		0		880	
P2.9.24	Fieldbus process data in 6 selection	0	10000		0		881	
P2.9.25	Fieldbus process data in 7 selection	0	10000		0		882	
P2.9.26	Fieldbus process data in 8 selection	0	10000		0		883	
P2.9.27 *	Fieldbus process data in 9 selection	0	10000		0		550	
P2.9.28 *	Fieldbus process data in 10 selection	0	10000		0		551	
P2.9.29 *	Fieldbus process data in 11 selection	0	10000		0		552	

Table 80: Fieldbus parameters

Index	Parameter	Min	Max	Unit	Default	Cust	ID	Description
P2.9.30 *	Fieldbus process data in 12 selection	0	10000		0		553	
P2.9.31 *	Fieldbus process data in 13 selection	0	10000		0		554	
P2.9.32 *	Fieldbus process data in 14 selection	0	10000		0		555	
P2.9.33 *	Fieldbus process data in 15 selection	0	10000		0		556	
P2.9.34 *	Fieldbus process data in 16 selection	0	10000		0		557	
P2.9.35	Fieldbus state machine	0	1		0		896	0 = Standard 1 = ProfiDrive

*] Visible only if the option board installed to AC drive supports 16 Process data items.

6.4.11 TORQUE CONTROL PARAMETERS (CONTROL KEYPAD: MENU M2 -> G2.10)

Table 81: Torque control parameters, G2.10

Index	Parameter	Min	Max	Unit	Default	Cust	ID	Description
P2.10.1	Torque limit	0.0	300.0	%	300.0		609	
P2.10.2	Torque limit control P-gain	0	32000		3000		610	
P2.10.3	Torque limit control I-gain	0	32000		200		611	
P2.10.4	Torque reference selection	0	8		0		641	0 = Not used 1 = AI1 2 = AI2 3 = AI3 4 = AI4 5 = AI1 joystick (-10 ...10 V) 6 = AI2 joystick (-10 ...10V) 7 = Torque reference from keypad, R3.5 8 = Fieldbus torque ref.
P2.10.5	Torque reference max.	-300.0	300.0	%	100		642	
P2.10.6	Torque reference min.	-300.0	300.0	%	0.0		643	
P2.10.7	Torque speed limit (OL)	0	3		1		644	0 = Max. frequency 1 = Selected frequency ref. 2 = Preset speed 7
P2.10.8	Minimum frequency for open loop torque control	0.00	P2.1.2	Hz	3.00		636	
P2.10.9	Torque controller P gain	0	32000		150		639	
P2.10.10	Torque controller I gain	0	32000		10		640	
NXP drives only								

Table 81: Torque control parameters, G2.10

Index	Parameter	Min	Max	Unit	Default	Cust	ID	Description
P2.10.11	Torque speed limit (CL)	0	7		2		1278	0 = CL speed control 1 = Pos/neg freq limits 2 = RampOut (-/+) 3 = NegFreqLimit-RampOut 4 = RampOut-Pos-FreqLimit 5 = RampOut Window 6 = 0-RampOut 7 = RampOut Window On/Off
P2.10.12	Torque reference filtering time	0	32000	ms	0		1244	
P2.10.13	Window negative	0.00	50.00	Hz	2.00		1305	
P2.10.14	Window positive	0.00	50.00	Hz	2.00		1304	
P2.10.15	Window negative off	0.00	P2.10.13	Hz	0.00		1307	
P2.10.16	Window positive off	0.00	P2.10.14	Hz	0.00		1306	
P2.10.17	Speed control output limit	0.0	300.0	%	300.0		1382	

6.4.12 NXP DRIVES: MASTER FOLLOWER PARAMETERS (CONTROL KEYPAD: MENU M2 - > G2.11)

Table 82: Master Follower parameters, G2.5

Index	Parameter	Min	Max	Unit	Default	Cust	ID	Description
P2.11.1	Master Follower mode	0	2		0		1324	0 = Single drive 1 = Master drive 2 = Follower drive
P2.11.2	Follower stop function	0	2		2		1089	0 = Coasting 1 = Ramping 2 = As Master
P2.11.3	Follower speed reference select	0	18		18		1081	0 = AI1 1 = AI2 2 = AI1+AI2 3 = AI1-AI2 4 = AI2-AI1 5 = AI1xAI2 6 = AI1 Joystick 7 = AI2 Joystick 8 = Keypad 9 = Fieldbus 10 = Motor potentiometer 11 = AI1, AI2 minimum 12 = AI1, AI2 maximum 13 = Max frequency 14 = AI1/AI2 selection 15 = Encoder 1 (C. 1) 16 = Encoder 2 (C. 3) 17 = Master Reference 18 = Master Ramp Out
P2.11.4	Follower torque reference select	0	9		9		1083	0 = Not used 1 = AI1 2 = AI2 3 = AI3 4 = AI4 5 = AI1 joystick 6 = AI2 joystick 7 = Torque reference from keypad, R3.5 8 = FB Torque Reference 9 = Master torque
P2.11.5	Speed share	-300.00	300.00	%	100.0		1241	

Table 82: Master Follower parameters, G2.5

Index	Parameter	Min	Max	Unit	Default	Cust	ID	Description
P2.11.6	Load share	0.0	500.0	%	100.0		1248	
P2.11.7	Master Follower mode 2	0	2		0		1093	0 = Single drive 1 = Master drive 2 = Follower drive
P2.11.8	Follower fault	0	2		0		1536	0 = Single drive 1 = Master drive 2 = Follower drive

6.4.13 FUNCTIONAL SAFETY (CONTROL KEYPAD: MENU M2 -> G2.12)**Table 83: Functional Safety, G2.12**

Index	Parameter	Min	Max	Unit	Default	Cust	ID	Description
P2.12.1	Response to safe stop request	0	3		0		542	0 = No action 1 = Stop by ramping, according to P2.1.4 2 = Stop by ramping, according to P2.4.4 3 = Stop by ramping, deceleration ramp according to ramp configured to the safety option board
P2.12.2	Response to SLS request	0	3		0		543	See P2.12.1
P2.12.3	Response to SDI request	0	1		0		544	0 = No action 1 = Prohibit speed reference on unintended direction

6.4.14 KEYPAD CONTROL (CONTROL KEYPAD: MENU M3)

The parameters for the selection of control place and direction on the keypad are listed below. See the Keypad control menu in the product's User Manual.

Table 84: Keypad control parameters, M3

Index	Parameter	Min	Max	Unit	Default	Cust	ID	Description
P3.1	Control place	0	3		1		125	0 = PC Control 1 = I/O terminal 2 = Keypad 3 = Fieldbus
R3.2	Keypad reference	P2.1.1	P2.1.2	Hz	0.00			
P3.3	Direction (on keypad)	0	1		0		123	0 = Forward 1 = Reverse
P3.4	Stop button	0	1		1		114	0 = Limited function of Stop button 1 = Stop button always enabled
R3.5	Torque reference	-300.0	300.0	%	0.0			

6.4.15 SYSTEM MENU (CONTROL KEYPAD: MENU M6)

For parameters and functions related to the general use of the AC drive, such as application and language selection, customised parameter sets or information about the hardware and software, see the product's User Manual.

6.4.16 EXPANDER BOARDS (CONTROL KEYPAD: MENU M7)

The M7 menu shows the expander and option boards attached to the control board and board related information. For more information, see the product's User Manual.

7 PUMP AND FAN CONTROL APPLICATION

7.1 INTRODUCTION

Select the Pump and Fan Control Application in menu M6 on page S6.2.

The Pump and Fan Control Application can be used to control one variable speed drive and up to four auxiliary drives. The PID controller of the AC drive controls the speed of the variable speed drive and gives control signals to start and stop the auxiliary drives to control the total flow. In addition to the eight parameter groups provided as standard, a parameter group for multi-pump and fan control functions is available.

The application has two control places on the I/O terminal. Place A is the pump and fan control and place B is the direct frequency reference. The control place is selected with input DIN6.

As already its name tells, the Pump and Fan Control Application is used to control the operation of pumps and fans. It can be used, for example, to decrease the delivery pressure in booster stations if the measured input pressure falls below a limit specified by the user.

The application utilizes external contactors for switching between the motors connected to the AC drive. The autochange feature provides the capability of changing the starting order of the auxiliary drives. Autochange between 2 drives (main drive + 1 auxiliary drive) is set as default, see Chapter 9.12 *Automatic changing between drives (application 7 only)*.

- All inputs and outputs are freely programmable.

Additional functions:

- Analogue input signal range selection
- Two frequency limit supervisions
- Torque limit supervision
- Reference limit supervision
- Second ramps and S-shape ramp programming
- Programmable Start/Stop and Reverse logic
- DC-brake at start and stop
- Three prohibit frequency areas
- Programmable U/f curve and switching frequency
- Autorestart
- Motor thermal and stall protection: fully programmable; off, warning, fault
- Motor underload protection
- Input and output phase supervision
- Sleep function

The parameters of the Pump and Fan Control Application are explained in Chapter 9 *Parameter descriptions* of this manual. The explanations are arranged according to the individual ID number of the parameter.

7.2 CONTROL I/O

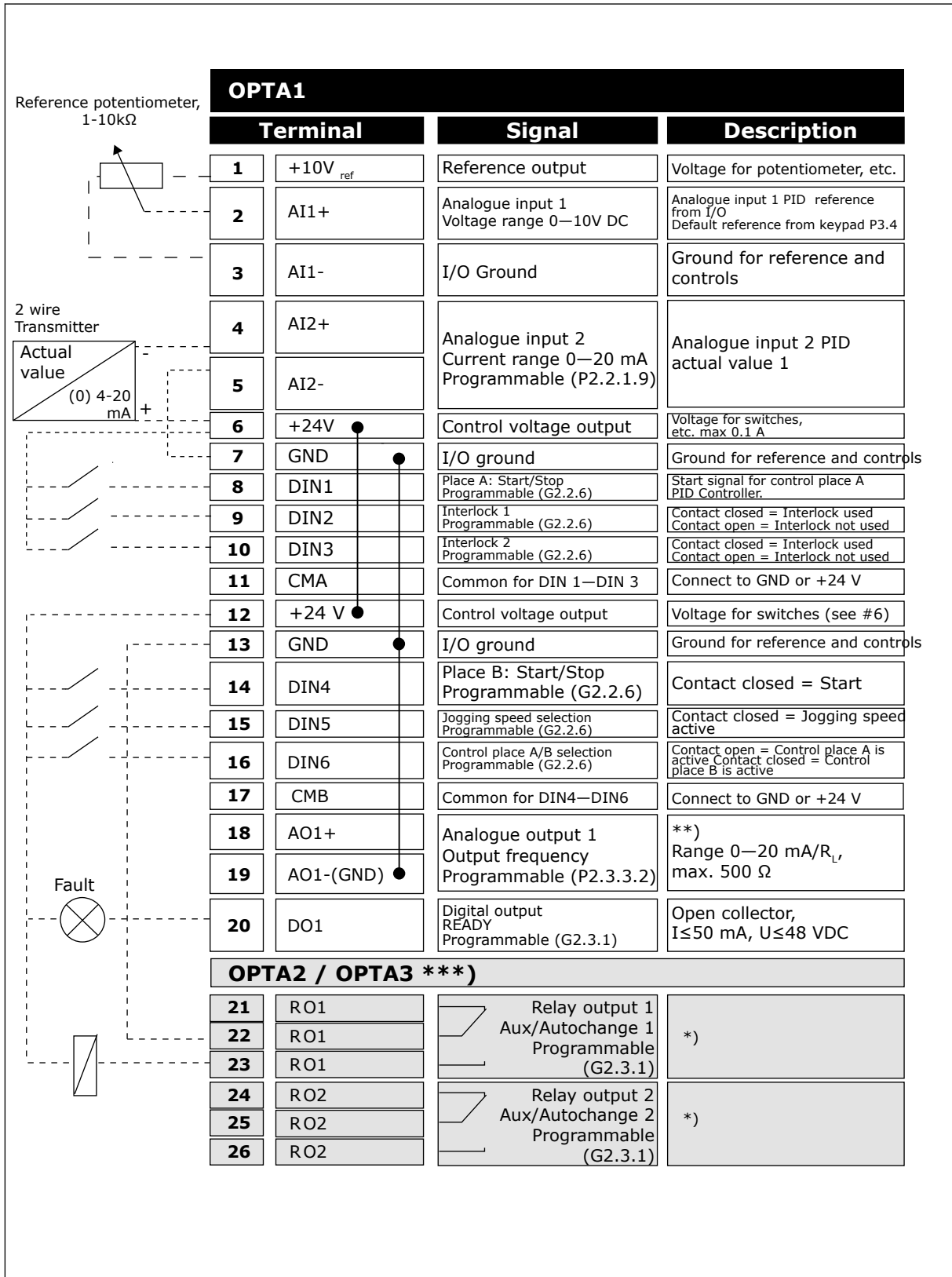

Fig. 19: Pump and fan control application default I/O configuration and connection example (with 2-wire transmitter)

*) See Table 93 Digital output signals (Control keypad: Menu M2 -> G2.3.1).

**) See Table 95 Analogue output 1 (Control keypad: Menu M2 -> G2.3.3), Table 96 Analogue output 2 (Control keypad: Menu M2 -> G2.3.4) and Table 97 Analogue output 3 (Control keypad: Menu M2 -> G2.3.7).

***) The option board A3 has no terminal for open contact on its second relay output (terminal 24 is missing).



NOTE!

See jumper selections below. More information in the product's User Manual.

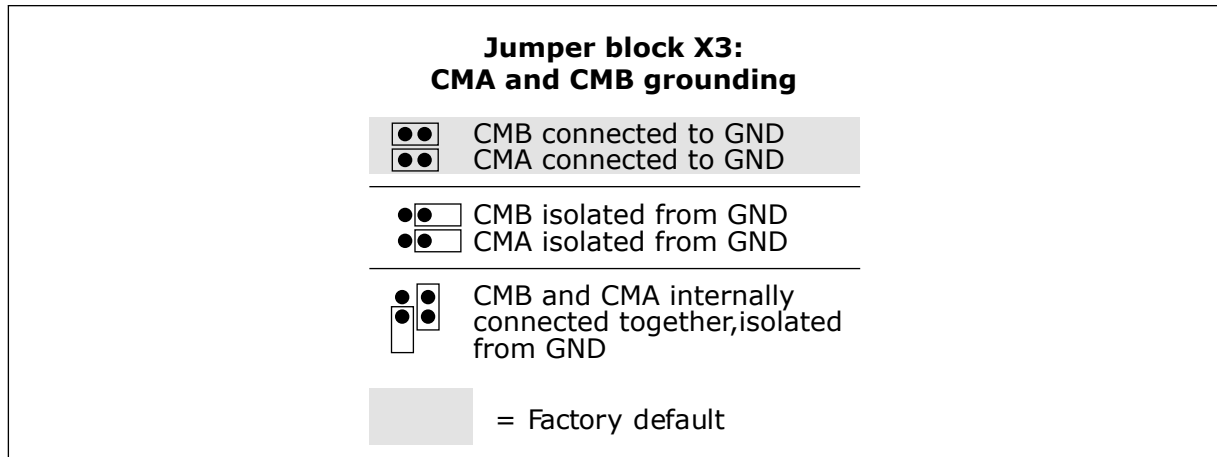

Fig. 20: Jumper selections

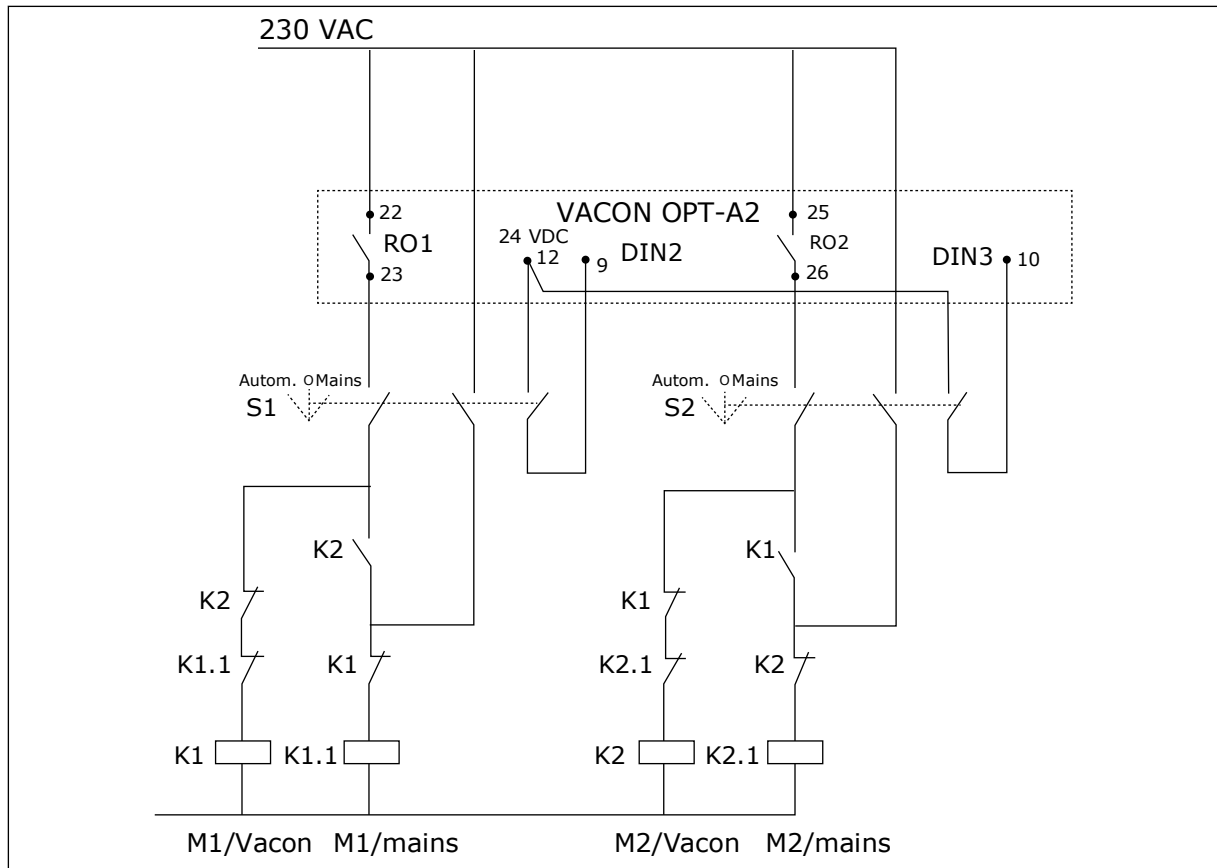

Fig. 21: Pump autochange system, principal control diagram

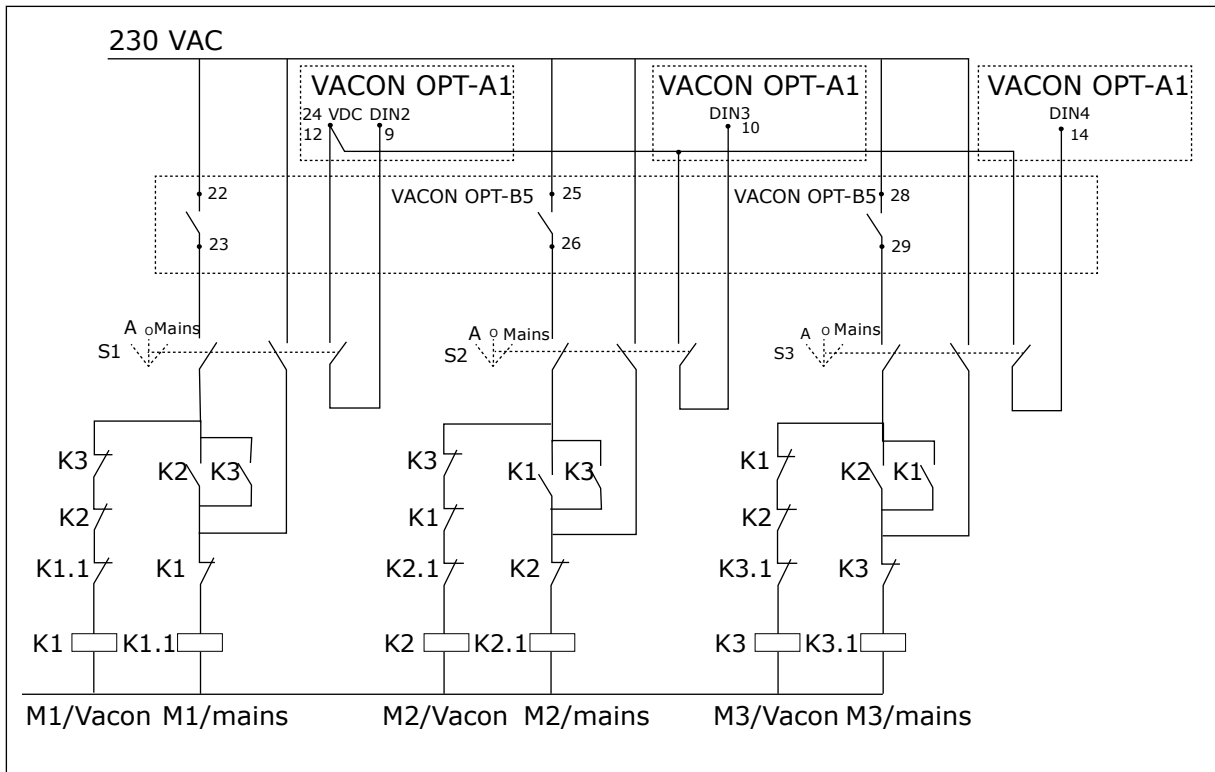

Fig. 22: Pump autochange system, principal control diagram

7.3 CONTROL SIGNAL LOGIC IN PUMP AND FAN CONTROL APPLICATION

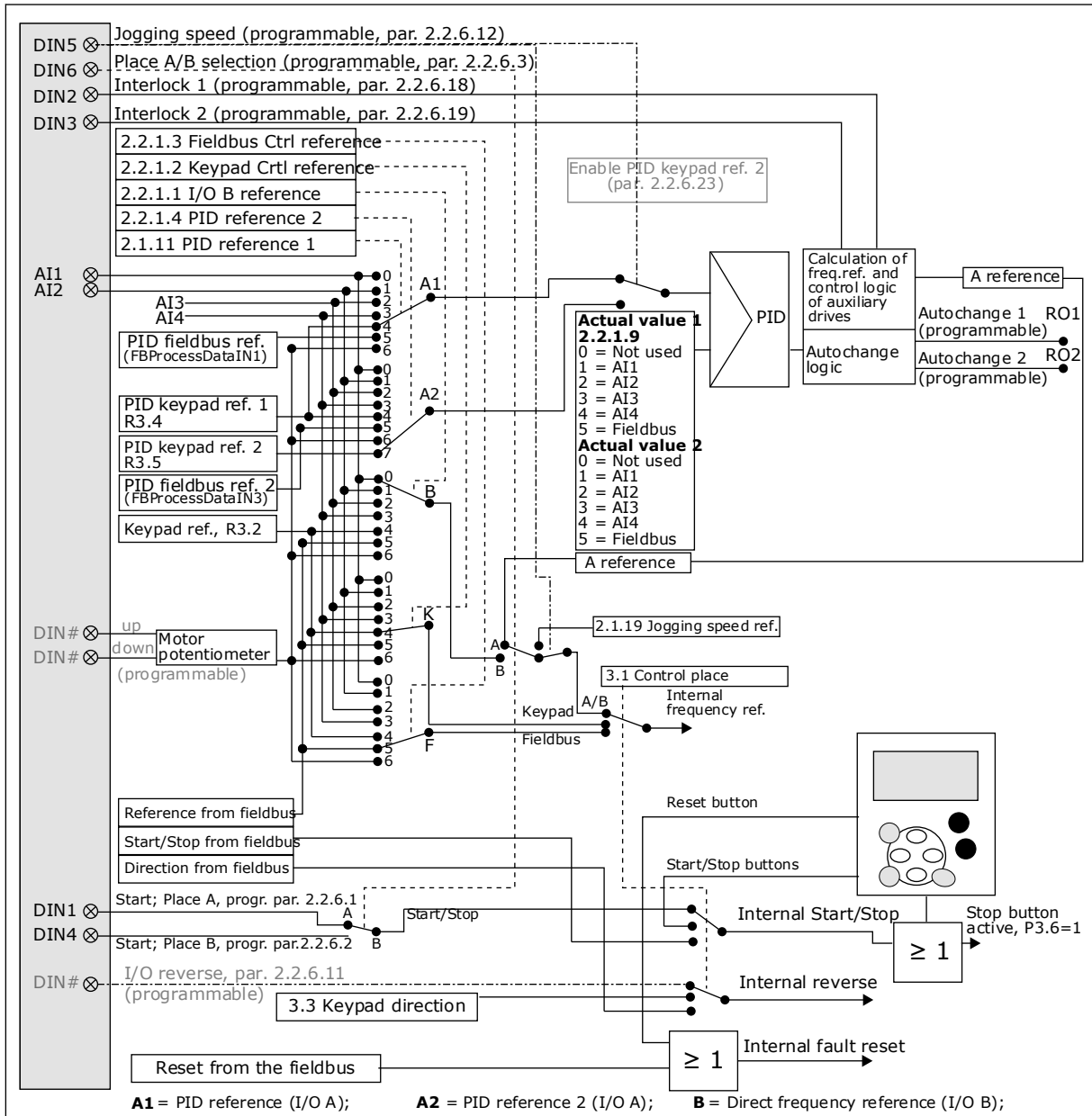

Fig. 23: Control signal logic of the Pump and Fan Control Application

7.4 PUMP AND FAN CONTROL APPLICATION - PARAMETER LISTS

7.4.1 MONITORING VALUES (CONTROL KEYPAD: MENU M1)

The monitoring values are the actual values of parameters and signals as well as statuses and measurements. Monitoring values cannot be edited.



NOTE!

The monitoring values V1.18 to V1.23 are available in the PFC control application only.

Table 85: Monitoring values

Index	Monitoring value	Unit	Form	ID	Description
V1.1	Output frequency	Hz	###	1	
V1.2	Frequency reference	Hz	###	25	
V1.3	Motor speed	rpm	#	2	
V1.4	Motor current	A	Varies	3	
V1.5	Motor torque	%	##	4	
V1.6	Motor power	%	##	5	
V1.7	Motor voltage	V	##	6	
V1.8	DC link voltage	V	#	7	
1.9	Unit temperature	°C	#	8	
1.10	Motor temperature	%	##	9	
V1.11	Analogue input 1	V/mA	###	13	
V1.12	Analogue input 2	V/mA	###	14	
V1.13	DIN 1, 2, 3			15	
V1.14	DIN 4, 5, 6			16	
V1.15	Analogue lout	mA	###	26	
V1.16	Analogue input 3	V/mA	###	27	
V1.17	Analogue input 4	V/mA	###	28	
V1.18	PID Reference	%		20	
V1.19	PID Actual value	%		21	
V1.20	PID Error value	%		22	
V1.21	PID Output	%		23	
V1.22	Running auxiliary drives			30	
V1.23	Special display for actual value			29	
V1.24	PT-100 temperature	°C	##	42	
G1.25	Multimonitoring items				
V1.26.1	Current	A	Varies	1113	

Table 85: Monitoring values

Index	Monitoring value	Unit	Form	ID	Description
V1.26.2	Torque	%	#. #	1125	
V1.26.3	DC-link Voltage	V		7	
V1.26.4	Status Word			43	
V1.26.5	Fault History		£	37	
V1.26.6	Motor Current	A	#. #	45	

7.4.2 BASIC PARAMETERS (CONTROL KEYPAD: MENU M2 -> G2.1)

Table 86: Basic parameters G2.1

Index	Parameter	Min	Max	Unit	Default	Cust	ID	Description
P2.1.1	Min frequency	0.00	P2.1.2	Hz	0.00		101	
P2.1.2	Max frequency	P2.1.1	320.00	Hz	50.00		102	
P2.1.3	Acceleration time 1	0.1	3000.0	s	1.0		103	
P2.1.4	Deceleration time 1	0.1	3000.0	s	1.0		104	
P2.1.5	Current limit	0.1 x IH	2 x IH	A	IL		107	
P2.1.6 *	Nominal voltage of the motor	180	690	V	NX2: 230V NX5: 400V NX6: 690V		110	
P2.1.7 *	Nominal frequency of the motor	8.00	320.00	Hz	50.00		111	
P2.1.8 *	Nominal speed of the motor	24	20 000	rpm	1440		112	
P2.1.9 *	Nominal current of the motor	0.1 x IH	2 X IH	A	IH		113	
P2.1.10 *	Motor cos phi	0.30	1.00		0.85		120	
P2.1.11 *	PID controller reference signal (Place A)	0	6		4		332	0 = AI1 1 = AI2 2 = AI3 3 = AI4 4 = PID ref from Keypad control page, P3.4 5 = PID ref. from fieldbus (FBProcessDataIN1) 6 = Motor potentiometer
P2.1.12	PID controller gain	0.0	1000.0	%	100.0		118	
P2.1.13	PID controller I-time	0.00	320.00	s	1.00		119	

Table 86: Basic parameters G2.1

Index	Parameter	Min	Max	Unit	Default	Cust	ID	Description
P2.1.14	PID controller D-time	0.00	10.00	s	0.00		132	
P2.1.15	Sleep frequency	0	P2.1.2	Hz	10.00		1016	
P2.1.16	Sleep delay	0	3600	s	30		1017	
P2.1.17	Wake up level	0.0	1000.0	%	25.0		1018	
P2.1.18	Wake up function	0	3		0		1019	0 = Wake-up at fall below wake up level (P2.1.17) 1 = Wake-up at exceeded wake up level (P2.1.17) 2 = Wake-up at fall below wake up level (P3.4/3.5) 3 = Wake-up at exceeded wake up level (P3.4/3.5)
P2.1.19	Jogging speed reference	0.00	P2.1.2	Hz	10.00		124	

* = Apply the Terminal to Function method (TTF) to these parameters (see Chapter 9.9 "Terminal to function" (TTF) programming principle).

7.4.3 INPUT SIGNALS

Table 87: Basic Settings (Control keypad: Menu M2 -> G2.2.1)

Index	Parameter	Min	Max	Unit	Default	Cust	ID	Description
P2.2.1.1 *	I/O B frequency reference selection	0	7		0		343	0 = AI1 1 = AI2 2 = AI3 3 = AI4 4 = Keypad reference 5 = Fieldbus reference (FB SpeedReference) 6 = Motor potentiometer 7 = PID controller
P2.2.1.2 *	Keypad control reference selection	0	7		4		121	As in P2.2.1.1
P2.2.1.3 *	Fieldbus control reference selection	0	7		5		122	As in P2.2.1.1
P2.2.1.4 *	PID Reference 2	0	7		7		371	0 = AI1 1 = AI2 2 = AI3 3 = AI4 4 = PID reference 1 from keypad 5 = Fieldbus reference (FBProcessDataIN3) 6 = Motor potentiometer 7 = PID reference 2 from keypad
P2.2.1.5	PID error value inversion	0	1		0		340	0 = No inversion 1 = Inversion
P2.2.1.6	PID reference rising time	0.1	100.0	s	5.0		341	
P2.2.1.7	PID reference falling time	0.1	100.0	s	5.0		342	

Table 87: Basic Settings (Control keypad: Menu M2 -> G2.2.1)

Index	Parameter	Min	Max	Unit	Default	Cust	ID	Description
P2.2.1.8 *	PID actual value selection	0	7		0		333	0 = Actual value 1 1 = Actual 1 + Actual 2 2 = Actual 1 - Actual 2 3 = Actual 1 * Actual 2 4 = Max (Actual 1, Actual 2) 5 = Min (Actual 1, Actual 2) 6 = Mean (Actual 1, Actual 2) 7 = Sqrt (Act1) + Sqrt (Act2) See P2.2.1.9 and P2.2.1.10
P2.2.1.9 *	Actual value 1 selection	0	5		2		334	0 = Not used 1 = AI1 (control board) 2 = AI2 (control board) 3 = AI3 4 = AI4 5 = Fieldbus (FBProcessDataIN2)
P2.2.1.10 *	Actual value 2 input	0	5		0		335	0 = Not used 1 = AI1 (control board) 2 = AI2 (control board) 3 = AI3 4 = AI4 5 = Fieldbus (FBProcessDataIN3)
P2.2.1.11	Actual value 1 minimum scale	-1600.0	1600.0	%	0.0		336	0 = No minimum scaling
P2.2.1.12	Actual value 1 maximum scale	-1600.0	1600.0	%	100.0		337	100 = No maximum scaling
P2.2.1.13	Actual value 2 minimum scale	-1600.0	1600.0	%	0.0		338	0 = No minimum scaling
P2.2.1.14	Actual value 2 maximum scale	-1600.0	1600.0	%	100.0		339	100 = No maximum scaling
P2.2.1.15	Motor potentiometer ramp time	0.1	2000.0	Hz/s	10.0		331	

Table 87: Basic Settings (Control keypad: Menu M2 -> G2.2.1)

Index	Parameter	Min	Max	Unit	Default	Cust	ID	Description
P2.2.1.16	Motor potentiometer frequency reference memory reset	0	2		1		367	0 = No reset 1 = Reset if stopped or powered down 2 = Reset if powered down
P2.2.1.17	Motor potentiometer PID reference memory reset	0	2		0		370	0 = No reset 1 = Reset if stopped or powered down 2 = Reset if powered down
P2.2.1.18	B reference scale, minimum	0.00	320.00	Hz	0.00		344	0 = Scaling off >0 = Scaled min. value
P2.2.1.19	B reference scale, maximum	0.00	320.00	Hz	0.00		345	0 = Scaling off >0 = Scaled min. value

* = Apply the Terminal to Function method (TTF) to these parameters (see Chapter 9.9 "Terminal to function" (TTF) programming principle).

Table 88: Analogue input 1 (Control keypad: Menu M2 -> G2.2.2)

Index	Parameter	Min	Max	Unit	Default	Cust	ID	Description
P2.2.2.1 **	AI1 signal selection	0.1	E.10		A.1		377	
P2.2.2.2	AI1 filter time	0.00	10.00	s	0.10		324	0 = No filtering
P2.2.2.3	AI1 signal range	0	2		0		320	0 = 0-10 V (0-20 mA*) 1 = 2-10 V (4-20 mA*) 2 = Customised *
P2.2.2.4	AI1 custom minimum setting	-160.00	160.00	%	0.00		321	
P2.2.2.5	AI1 custom maximum setting	-160.00	160.00	%	100.00		322	
P2.2.2.6	AI1 signal inversion	0	1		0		323	0 = Not inverted 1 = Inverted

* = Remember to place jumpers of block X2 accordingly. See the product's User Manual.

** = Apply the Terminal to Function method (TTF) to these parameters (see Chapter 9.9 "Terminal to function" (TTF) programming principle)

Table 89: Analogue input 2 (Control keypad: Menu M2 -> G2.2.3)

Index	Parameter	Min	Max	Unit	Default	Cust	ID	Description
P2.2.3.1 **	AI2 signal selection	0.1	E.10		A.2		388	
P2.2.3.2	AI2 filter time	0.00	10.00	s	0.10		329	0 = No filtering
P2.2.3.3	AI2 signal range	0	2		1		325	0 = 0-10 V (0-20mA*) 1 = 2-10 V (4-20 mA*) 2 = Customised *
P2.2.3.4	AI2 custom minimum setting	-160.00	160.00	%	0.00		326	
P2.2.3.5	AI2 custom maximum setting	-160.00	160.00	%	100.00		327	
P2.2.3.6	AI2 inversion	0	1		0		328	0 = Not inverted 1 = Inverted

* = Remember to place jumpers of block X2 accordingly. See the product's User Manual.

** = Apply the Terminal to Function method (TTF) to these parameters (see Chapter 9.9 "Terminal to function" (TTF) programming principle).

Table 90: Analogue input 3 (Control keypad: Menu M2 -> G2.2.4)

Index	Parameter	Min	Max	Unit	Default	Cust	ID	Description
P2.2.4.1 **	AI3 signal selection	0.1	E.10		0.1		141	
P2.2.4.2	AI3 filter time	0.00	10.00	s	0.10		142	0 = No filtering
P2.2.4.3	AI3 signal range	0	2		1		143	0 = 0-10 V (0-20mA*) 1 = 2-10 V (4-20 mA*) 1 = Customised *
P2.2.4.4	AI3 custom minimum setting	-160.00	160.00	%	0.00		144	
P2.2.4.5	AI3 custom maximum setting	-160.00	160.00	%	100.00		145	
P2.2.4.6	AI3 signal inversion	0	1		0		151	0 = Not inverted 1 = Inverted

* = Remember to place jumpers of block X2 accordingly. See the product's User Manual.

** = Apply the Terminal to Function method (TTF) to these parameters (see Chapter 9.9 "Terminal to function" (TTF) programming principle)

Table 91: Analogue input 4 (Control keypad: Menu M2 -> G2.2.5)

Index	Parameter	Min	Max	Unit	Default	Cust	ID	Description
P2.2.5.1 **	AI4 signal selection	0.1	E.10		0.1		152	
P2.2.5.2	AI4 filter time	0.00	10.00	s	0.00		153	0 = No filtering
P2.2.5.3	AI4 signal range	0	2		1		154	0 = 0-10 V (0-20mA*) 1 = 2-10 V (4-20 mA*) 2 = Customised *
P2.2.5.4	AI4 custom minimum setting	-160.00	160.00	%	0.00		155	
P2.2.5.5	AI4 custom maximum setting	-160.00	160.00	%	100.00		156	
P2.2.5.6	AI4 signal inversion	0	1		0		162	0 = Not inverted 1 = Inverted

* = Remember to place jumpers of block X2 accordingly. See the product's User Manual.

** = Apply the Terminal to Function method (TTF) to these parameters (see Chapter 9.9 "Terminal to function" (TTF) programming principle)

Table 92: Digital inputs (Control keypad: Menu M2 -> G2.2.4)

Index	Parameter	Min	Default	Cust	ID	Description
P2.2.6.1 *	Start A signal	0.1	A.1		423	
P2.2.6.2 *	Start B signal	0.1	A.4		424	
P2.2.6.3 *	Control place A/B selection	0.1	A.6		425	
P2.2.6.4 *	External fault (cc)	0.1	0.1		405	
P2.2.6.5 *	External fault (oc)	0.1	0.2		406	
P2.2.6.6 *	Run enable	0.1	0.2		407	
P2.2.6.7 *	Acc/Dec time selection	0.1	0.1		408	
P2.2.6.8 *	Control from I/O terminal	0.1	0.1		409	
P2.2.6.9 *	Control from keypad	0.1	0.1		410	
P2.2.6.1 *	Control from fieldbus	0.1	0.1		411	
P2.2.6.11 *	Reverse	0.1	0.1		412	
P2.2.6.12 *	Jogging speed	0.1	A.5		413	
P2.2.6.13 *	Fault reset	0.1	0.1		414	
P2.2.6.14 *	Acc/Dec prohibit	0.1	0.1		415	
P2.2.6.15 *	DC braking	0.1	0.1		416	
P2.2.6.16 *	Motor potentiometer reference DOWN	0.1	0.1		417	
P2.2.6.17 *	Motor potentiometer reference UP	0.1	0.1		418	
P2.2.6.18 *	Autochange 1 Interlock	0.1	A.2		426	
P2.2.6.19 *	Autochange 2 Interlock	0.1	A.3		427	

Table 92: Digital inputs (Control keypad: Menu M2 -> G2.2.4)

Index	Parameter	Min	Default	Cust	ID	Description
P2.2.6.20 *	Autochange 3 Interlock	0.1	0.1		428	
P2.2.6.21 *	Autochange 4 Interlock	0.1	0.1		429	
P2.2.6.22 *	Autochange 5 Interlock	0.1	0.1		430	
P2.2.6.23 *	PID reference 2	0.1	0.1		431	

cc = closing contact

oc = opening contact

* Apply the Terminal to Function method (TTF) to these parameters (see chapter 9.9 "Terminal to function" (TTF) programming principle).

7.4.4 OUTPUT SIGNALS

Use TTF method to program for all Digital output signal parameters.

Table 93: Digital output signals (Control keypad: Menu M2 -> G2.3.1)

Index	Parameter	Min	Default	Cust	ID	Description
P2.3.1.1	Ready	0.1	0.1		432	
P2.3.1.2	Run	0.1	0.1		433	
P2.3.1.3	Fault	0.1	A.1		434	
P2.3.1.4	Inverted fault	0.1	0.1		435	
P2.3.1.5	Warning	0.1	0.1		436	
P2.3.1.6	External fault	0.1	0.1		437	
P2.3.1.7	Reference fault/ warning	0.1	0.1		438	
P2.3.1.8	Overtemperature warning	0.1	0.1		439	
P2.3.1.9	Reverse	0.1	0.1		440	
P2.3.1.10	Unrequested direction	0.1	0.1		441	
P2.3.1.11	At speed	0.1	0.1		442	
P2.3.1.12	Jogging speed	0.1	0.1		443	
P2.3.1.13	External control place	0.1	0.1		444	
P2.3.1.14	External brake control	0.1	0.1		445	See ID445 in Chapter 9 <i>Parameter descriptions</i> .
P2.3.1.15	External brake control, inverted	0.1	0.1		446	
P2.3.1.16	Output frequency limit 1 supervision	0.1	0.1		447	See ID315 in Chapter 9 <i>Parameter descriptions</i> .
P2.3.1.17	Output frequency limit 2 supervision	0.1	0.1		448	See ID346 in Chapter 9 <i>Parameter descriptions</i> .
P2.3.1.18	Reference limit supervision	0.1	0.1		449	See ID350 in Chapter 9 <i>Parameter descriptions</i> .
P2.3.1.19	Drive temperature limit supervision	0.1	0.1		450	See ID354 in Chapter 9 <i>Parameter descriptions</i> .
P2.3.1.20	Torque limit supervision	0.1	0.1		451	See ID348 in Chapter 9 <i>Parameter descriptions</i> .
P2.3.1.21	Motor thermal protection	0.1	0.1		452	

Table 93: Digital output signals (Control keypad: Menu M2 -> G2.3.1)

Index	Parameter	Min	Default	Cust	ID	Description
P2.3.1.22	Analogue input supervision limit	0.1	0.1		463	
P2.3.1.23	Motor regulator activation	0.1	0.1		454	
P2.3.1.24	Fieldbus DIN 1	0.1	0.1		455	
P2.3.1.25	Fieldbus DIN 2	0.1	0.1		456	
P2.3.1.26	Fieldbus DIN 3	0.1	0.1		457	
P2.3.1.27	Autochange 1/Aux 1 control	0.1	B.1		458	
P2.3.1.28	Autochange 2/Aux 2 control	0.1	B.2		459	
P2.3.1.29	Autochange 3/Aux 3 control	0.1	0.1		460	
P2.3.1.30	Autochange 4/Aux 4 control	0.1	0.1		461	
P2.3.1.31	Autochange 5	0.1	0.1		462	

**CAUTION!**

Be ABSOLUTELY sure not to connect two functions to one and same output in order to avoid function overruns and to ensure flawless operation.

Table 94: Limit settings (Control keypad: Menu M2 -> G2.3.2)

Index	Parameter	Min	Max	Unit	Default	Cust	ID	Description
P2.3.2.1	Output frequency limit 1 supervision	0	2		0		315	0 = No limit 1 = Low limit supervision 2 = High limit supervision
P2.3.2.2	Output frequency limit 1; Supervised value	0.00	320.00	Hz	0.00		316	
P2.3.2.3	Output frequency limit 2 supervision	0	2		0		346	0 = No limit 1 = Low limit supervision 2 = High limit supervision
P2.3.2.4	Output frequency limit 2; Supervised value	0.00	320.00	Hz	0.00		347	
P2.3.2.5	Torque limit supervision	0	2		0		348	0 = Not used 1 = Low limit supervision 2 = High limit supervision
P2.3.2.6	Torque limit supervision value	-300.0	300.0	%	100.0		349	
P2.3.2.7	Reference limit supervision	0	2		0		350	0 = Not used 1 = Low limit 2 = High limit
P2.3.2.8	Reference limit supervision value	0.0	100.0	%	0.0		351	
P2.3.2.9	External brake-off delay	0.0	100.0	s	0.5		352	
P2.3.2.10	External brake-on delay	0.0	100.0	s	1.5		353	
P2.3.2.11	FC temperature supervision	0	2		0		354	0 = Not used 1 = Low limit 2 = High limit
P2.3.2.12	FC temperature supervised value	-10	100	°C	40		355	
P2.3.2.13	Supervised analogue input	0	1		0		372	0 = AI1 1 = AI2

Table 94: Limit settings (Control keypad: Menu M2 -> G2.3.2)

Index	Parameter	Min	Max	Unit	Default	Cust	ID	Description
P2.3.2.14	Analogue input limit supervision	0	2		0		373	0 = No limit 1 = Low limit supervision 2 = High limit supervision
P2.3.2.15	Analogue input supervised value	0.00	100.00	%	0.00		374	

Table 95: Analogue output 1 (Control keypad: Menu M2 -> G2.3.3)

Index	Parameter	Min	Max	Unit	Default	Cust	ID	Description
P2.3.3.1 *	Analogue output 1 signal selection	0.1	E.10		A.1		464	
P2.3.3.2	Analogue output function	0	14		1		307	0 = Not used (20 mA / 10 V) 1 = Output freq. (0-fmax) 2 = Freq. reference (0-fmax) 3 = Motor speed (0-Motor nominal speed) 4 = Motor current (0-InMotor) 5 = Motor torque (0-TnMotor) 6 = Motor power (0-PnMotor) 7 = Motor voltage (0-UnMotor) 8 = DC link volt (0-1000V) 9 = PID controller ref. value 10 = PID contr. act.value 1 11 = PID contr. act.value 2 12 = PID contr. error value 13 = PID controller output 14 = PT100 temperature
P2.3.3.3	Analogue output filter time	0.00	10.00	s	1.00		308	0 = No filtering
P2.3.3.4	Analogue output inversion	0	1		0		309	0 = Not inverted 1 = Inverted
P2.3.3.5	Analogue output minimum	0	1		0		310	0 = 0 mA (0 V) 1 = 4 mA (2 V)
P2.3.3.6	Analogue output scale	10	1000	%	100		311	
P2.3.3.7	Analogue output offset	-100.00	100.00	%	0.00		375	

* = Use TTF method to program these parameters.

Table 96: Analogue output 2 (Control keypad: Menu M2 -> G2.3.4)

Index	Parameter	Min	Max	Unit	Default	Cust	ID	Description
P2.3.6.1 *	Analogue output 2 signal selection	0.1	E.10		0.1		471	
P2.3.6.2	Analogue output 2 function	0	14		0		472	See P2.3.3.2
P2.3.6.3	Analogue output 2 filter time	0.00	10.00	s	1.00		473	0 = No filtering
P2.3.6.4	Analogue output 2 inversion	0	1		0		474	0 = Not inverted 1 = Inverted
P2.3.6.5	Analogue output 2 minimum	0	1		0		475	0 = 0 mA (0 V) 1 = 4 mA (2 V)
P2.3.6.6	Analogue output 2 scale	10	1000	%	100		476	
P2.3.6.7	Analogue output 2 offset	-100.00	100.00	%	0.00		477	

* = Use TTF method to program these parameters.

Table 97: Analogue output 3 (Control keypad: Menu M2 -> G2.3.7)

Index	Parameter	Min	Max	Unit	Default	Cust	ID	Description
P2.3.5.1 *	Analogue output 3 signal selection	0.1	E.10		0.1		478	
P2.3.5.2	Analogue output 3 function	0	4		4		479	See P2.3.5.2
P2.3.5.3	Analogue output 3 filter time	0.00	10.00	s	1.00		480	0 = No filtering
P2.3.5.4	Analogue output 3 inversion	0	1		0		481	0 = Not inverted 1 = Inverted
P2.3.5.5	Analogue output 2 minimum	0	1		0		482	0 = 0 mA (0 V) 1 = 4 mA (2 V)
P2.3.5.6	Analogue output 3 scale	10	1000	%	100		483	
P2.3.5.7	Analogue output 3 offset	-100.00	100.00	%	0.00		484	

* = Use TTF method to program these parameters.

7.4.5 DRIVE CONTROL PARAMETERS (CONTROL KEYPAD: MENU M2 -> G2.4)

Table 98: Drive control parameters, G2.4

Index	Parameter	Min	Max	Unit	Default	Cust	ID	Description
P2.4.1	Ramp 1 shape	0.0	10.0	s	0.1		500	0 = Linear 100 = full acc/dec inc/dec times
P2.4.2	Ramp 2 shape	0.0	10.0	s	0.0		501	0 = Linear 100 = full acc/dec inc/dec times
P2.4.3	Acceleration time 2	0.1	3000.0	s	1.0		502	
P2.4.4	Deceleration time 2	0.1	3000.0	s	1.0		503	
P2.4.5	Brake chopper	0	4		0		504	0 = Disabled 1 = Used when running 2 = External brake chopper 3 = Used when stopped/running 4 = used when run- ning (no testing)
P2.4.6	Start function	0	2		0		505	0 = Ramp 1 = Flying start 2 = Conditional fly- ing start
P2.4.7	Stop function	0	3		0		506	0 = Coasting 1 = Ramp 2 = Ramp+Run enable coast 3 = Coast+Run enable ramp
P2.4.8	DC braking cur- rent	0.00	IL	A	0.7 x IH		507	
P2.4.9	DC braking time at stop	0.00	600.00	s	0.00		508	0 = DC brake is off at stop
P2.4.10	Frequency to start DC braking during ramp stop	0.10	10.00	Hz	1.50		515	
P2.4.11	DC braking time at start	0.00	600.00	s	0.00		516	0 = DC brake is off at start
P2.4.12 *	Flux brake	0	1		0		520	0 = Off 0 = On

Table 98: Drive control parameters, G2.4

Index	Parameter	Min	Max	Unit	Default	Cust	ID	Description
P2.4.13	Flux braking current	0.00	IL	A	IH		519	

7.4.6 PROHIBIT FREQUENCY PARAMETERS (CONTROL KEYPAD: MENU M2 -> G2.5)**Table 99: Prohibit frequency parameters, G2.5**

Index	Parameter	Min	Max	Unit	Default	Cust	ID	Description
P2.5.1	Prohibit frequency range 1 low limit	-1.00	320.00	Hz	0.00		509	0 = Not used
P2.5.2	Prohibit frequency range 1 high limit	0.00	320.00	Hz	0.00		510	0 = Not used
P2.5.3	Prohibit frequency range 2 low limit	0.00	320.00	Hz	0.00		511	0 = Not used
P2.5.4	Prohibit frequency range 2 high limit	0.00	320.00	Hz	0.00		512	0 = Not used
P2.5.5	Prohibit frequency range 3 low limit	0.00	320.00	Hz	0.00		513	0 = Not used
P2.5.6	Prohibit frequency range 3 high limit	0.00	320.00	Hz	0.00		514	0 = Not used
P2.5.7	Prohibit acc./dec. ramp	0.1	10.0	x	1.0		518	

7.4.7 MOTOR CONTROL PARAMETERS (CONTROL KEYPAD: MENU M2 -> G2.6)

Table 100: Motor control parameters, G2.6

Index	Parameter	Min	Max	Unit	Default	Cust	ID	Description
P2.6.1 *	Motor control mode	0	1		0		600	0 = Frequency control 1 = Speed control
P2.6.2 *	U/f optimisation	0	1		0		109	0 = Not used 1 = Automatic torque boost
P2.6.3 *	U/f ratio selection	0	3		0		108	0 = Linear 1 = Squared 2 = Programmable 3 = Linear with flux optim
P2.6.4 *	Field weakening point	8.00	320.00	Hz	50.00		602	
P2.6.5 *	Voltage at field weakening point	10.00	200.00	%	100.00		603	
P2.6.6 *	U/f curve midpoint frequency	0.00	P2.6.4	Hz	50.00		604	
P2.6.7 *	U/f curve midpoint voltage	0.00	100.00	%	100.00		605	
P2.6.8 *	Output voltage at zero frequency	0.00	40.00	%	Varies		606	
P2.6.9	Switching frequency	1	Varies	kHz	Varies		601	See Table 160 Size-dependent switching frequencies for exact values.
P2.6.10	Overvoltage controller	0	2		1		607	0 = Not used 1 = Used (no ramping) 2 = Used (ramping)
P2.6.11	Undervoltage controller	0	1		1		608	0 = Not used 1 = Used 2 = Used (ramping to zero)
P2.6.12	Identification						631	0 = No action 1 = Identification w/o run

* = Apply the Terminal to Function (TTF) to these parameters (see Chapter 9.9 "Terminal to function" (TTF) programming principle).

7.4.8 PROTECTIONS (CONTROL KEYPAD: MENU M2 -> G2.7)

Table 101: Protections, G2.7

Index	Parameter	Min	Max	Unit	Default	Cust	ID	Description
P2.7.1	Response to 4 mA reference fault	0	5		4		700	0 = No response 1 = Warning 2 = Warning+Previous Freq. 3 = Wrng+Preset-Freq 2.7.2 4 = Fault, stop acc. to 2.4.7 5 = Fault, stop by coasting
P2.7.2	4 mA reference fault frequency	0.00	P2.1.2	Hz	0.00		728	
P2.7.3	Response to external fault	0	3		2		701	0 = No response 1 = Warning 2 = Fault, stop acc. to 2.4.7
P2.7.4	Input phase supervision	0	3		0		730	3 = Fault, stop by coasting
P2.7.5	Response to undervoltage fault	0	1		0		727	0 = Fault stored in history Fault not stored
P2.7.6	Output phase supervision	0	3		2		702	0 = No response 1 = Warning 2 = Fault, stop acc. to 2.4.7
P2.7.7	Earth fault protection	0	3		2		703	3 = Fault, stop by coasting
P2.7.8	Thermal protection of the motor	0	3		2		704	
P2.7.9	Motor ambient temperature factor	-100.0	100.0	%	0.0		705	
P2.7.10	Motor cooling factor at zero speed	0.0	150.0	%	40.0		706	
P2.7.11	Motor thermal time constant	1	200	min	Varies		707	
P2.7.12	Motor duty cycle	0	150	%	100		708	
P2.7.13	Stall protection	0	3		1		709	0 = No response 1 = Warning 2 = Fault, stop acc. to 2.4.7 3 = Fault, stop by coasting

Table 101: Protections, G2.7

Index	Parameter	Min	Max	Unit	Default	Cust	ID	Description
P2.7.14	Stall current	0.00	2 x IH	A	1H		710	
P2.7.15	Stall time limit	1.00	120.00	s	15.00		711	
P2.7.16	Stall frequency limit	1.00	P2.1.2	Hz	25.00		712	
P2.7.17	Underload protection	0	3		0		713	0 = No response 1 = Warning 2 = Fault, stop acc. to 2.4.7 3 = Fault, stop by coasting
P2.7.18	UP ffrom Torque	10.0	150.0	%	50.0		714	
P2.7.19	Zero frequency load	5.0	150.0	%	10.0		715	
P2.7.20	Underload protection time limit	2.00	600.00	s	20.00		716	
P2.7.21	Response to thermistor fault	0	3		2		732	0 = No response 1 = Warning 2 = Fault, stop acc. to 2.4.7 3 = Fault, stop by coasting
P2.7.22	Response to field-bus fault	0	3		2		733	See P2.7.21
P2.7.23	Response to slot fault	0	3		2		734	See P2.7.21
P2.7.24	No. of PT100 inputs	0	3		0		739	
P2.7.25	Response to PT100 fault	0	3		0		740	0 = No response 1 = Warning 2 = Fault, stop acc. to 2.4.7 3 = Fault, stop by coasting
P2.7.26	PT100 warning limit	-30.0	200.0	°C	120.0		741	
P2.7.27	PT100 fault limit	-30.0	200.0	°C	130.0		742	

7.4.9 AUTORESTART PARAMETERS (CONTROL KEYPAD: MENU M2 -> G2.8)

Table 102: Autorestart parameters, G2.8

Index	Parameter	Min	Max	Unit	Default	Cust	ID	Description
P2.8.1	Wait time	0.10	10.00	s	0.50		717	
P2.8.2	Trial time	0.00	60.00	s	30.00		718	
P2.8.3	Start function	0	2		0		719	0 = Ramp 1 = Flying start 2 = According to P2.4.6
P2.8.4	Number of tries after undervoltage trip	0	10		1		720	
P2.8.5	Number of tries after overvoltage trip	0	10		1		721	
P2.8.6	Number of tries after overcurrent trip	0	3		1		722	
P2.8.7	Number of tries after 4mA reference trip	0	10		1		723	
P2.8.8	Number of tries after motor temperature fault trip	0	10		1		726	
P2.8.9	Number of tries after external fault trip	0	10		0		725	
P2.8.10	Number of tries after underload fault trip	0	10		1		738	

7.4.10 PUMP AND FAN CONTROL PARAMETERS (CONTROL KEYPAD: MENU M2 -> G2.9)

Table 103: Pump and fan control parameters

Index	Parameter	Min	Max	Unit	Default	Cust	ID	Description
P2.9.1	Number of auxiliary drives	0	4		1		1001	
P2.9.2	Start frequency, auxiliary drive 1	P2.9.3	320.00	Hz	51.00		1002	
P2.9.3	Stop frequency, auxiliary drive 1	P2.1.1	P2.9.2	Hz	10.00		1003	
P2.9.4	Start frequency, auxiliary drive 2	P2.9.5	320.00	Hz	51.00		1004	
P2.9.5	Stop frequency, auxiliary drive 2	P2.1.1	P2.9.4	Hz	10.00		1005	
P2.9.6	Start frequency, auxiliary drive 3	P2.9.7	320.00	Hz	51.00		1006	
P2.9.7	Stop frequency, auxiliary drive 3	P2.1.1	P2.9.6	Hz	10.00		1007	
P2.9.8	Start frequency, auxiliary drive 4	P2.9.9	320.00	Hz	51.00		1008	
P2.9.9	Stop frequency, auxiliary drive 4	P2.1.1	P2.9.8	Hz	10.00		1009	
P2.9.10	Start delay, auxiliary drives	0.0	300.0	s	4.0		1010	
P2.9.11	Stop delay, auxiliary drives	0.0	300.0	s	2.0		1011	
P2.9.12	Reference step, auxiliary drive 1	0.00	100.00	%	0.00		1012	
P2.9.13	Reference step, auxiliary drive 2	0.00	100.00	%	0.00		1013	
P2.9.14	Reference step, auxiliary drive 3	0.00	100.00	%	0.00		1014	
P2.9.15	Reference step, auxiliary drive 4	0.00	100.00	%	0.00		1015	
P2.9.16	PID controller bypass	0	1		0		1020	1 = PID contr. bypassed

Table 103: Pump and fan control parameters

Index	Parameter	Min	Max	Unit	Default	Cust	ID	Description
P2.9.17	Analogue input selection for input pressure measurement	0	5		0		1021	0 = Not used 1 = AI1 2 = AI2 3 = AI3 4 = AI4 5 = Fieldbus signal (FBProcessDataIN3)
P2.9.18	Input pressure high limit	0.0	100.0	%	30.0		1022	
P2.9.19	Input pressure low limit	0.0	100.0	%	20.0		1023	
P2.9.20	Output pressure drop	0.0	100.0	%	30.0		1024	
P2.9.21	Frequency drop delay	0.0	300.0	s	0.0		1025	0 = No delay 300 = No frequency drop nor increase
P2.9.22	Frequency increase delay	0.0	300.0	s	0.0		1026	0 = No delay 300 = No frequency drop nor increase
P2.9.23	Interlock selection	0	2		1		1032	0 = Interlocks not used 1 = Set new interlock last; update order after value of P2.9.26 or Stop state 2 = Stop and update order immediately
P2.9.24	Autochange	0	1		1		1027	0 = Not used 1 = Autochange used
P2.9.25	Autoch. and interl. automatics selection	0	1		1		1028	0 = Auxiliary drives only 1 = All drives
P2.9.26	Autochange interval	0.0	3000.0	h	48.0		1029	0.0 = TEST=40 s
P2.9.27	Autochange; Maximum number of auxiliary drives	0	4		1		1030	
P2.9.28	Autochange frequency limit	0.00	P2.1.2	Hz	25.00		1031	

Table 103: Pump and fan control parameters

Index	Parameter	Min	Max	Unit	Default	Cust	ID	Description
P2.9.29	Actual value special display minimum	0	30000		0		1033	
P2.9.30	Actual value special display maximum	0	30000		100		1034	
P2.9.31	Actual value special display decimals	0	4		1		1035	
P2.9.32	Actual value special display unit	0	28		4		1036	See ID1036 in Chapter 9 Parameter descriptions.

7.4.11 KEYPAD CONTROL (CONTROL KEYPAD: MENU M3)

The parameters for the selection of control place and direction on the keypad are listed below. See the Keypad control menu in the product's User Manual.

Table 104: Keypad control parameters, M3

Index	Parameter	Min	Max	Unit	Default	Cust	ID	Description
P3.1	Control place	1	3		1		125	1 = I/O terminal 2 = Keypad 3 = Fieldbus
P3.2	Keypad reference	P2.1.1	P2.1.2	Hz	0.00			
P3.3	Direction (on keypad)	0	1		0		123	0 = Forward 1 = Reverse
P3.4	PID reference 1	0.00	100.00	%	0.00		167	
P3.5	PID reference 2	0.00	100.00	%	0.00		168	
R3.6	Stop button	0	1		1		114	0 = Limited function of Stop button 1 = Stop button always enabled

7.4.12 SYSTEM MENU (CONTROL KEYPAD: MENU M6)

For parameters and functions related to the general use of the AC drive, such as application and language selection, customised parameter sets or information about the hardware and software, see the product's User Manual.

7.4.13 EXPANDER BOARDS (CONTROL KEYPAD: MENU M7)

The M7 menu shows the expander and option boards attached to the control board and board related information. For more information, see the product's User Manual.

8 MONITORING VALUE DESCRIPTIONS

This chapter gives you the basic descriptions of all monitoring values.

1 OUTPUT FREQUENCY (V1.1)

This monitoring value shows the actual output frequency to the motor.

2 MOTOR SPEED (V1.3)

This monitoring value shows the actual speed of the motor in rpm (calculated value).

3 MOTOR CURRENT (V1.4)

This monitoring value shows the measured current of the motor.

4 MOTOR TORQUE (V1.5)

This monitoring value shows the actual torque of the motor (calculated value). When the torque is in counterclockwise direction, the value is negative.

5 MOTOR POWER (V1.6)

This monitoring value shows the actual shaft power of the motor (calculated value) as a percentage of the motor nominal power.

6 MOTOR VOLTAGE (V1.7)

This monitoring value shows the measured output voltage to the motor.

7 DC-LINK VOLTAGE (V1.8, V1.26.3)

This monitoring value shows the measured voltage in the DC-link of the drive.

8 UNIT TEMPERATURE (V1.9)

This monitoring value shows the measured heatsink temperature of the drive.

9 MOTOR TEMPERATURE (V1.10)

This monitoring value shows the calculated motor temperature in percentage of the nominal working temperature.

13 ANALOGUE INPUT 1 (V1.11)

This monitoring value shows the status of the analogue input 1.

14 ANALOGUE INPUT 2 (V1.12)

This monitoring value shows the status of the analogue input 2.

15 DIN1, DIN2, DIN3 (V1.13, V1.15)

This monitoring value shows the status of the digital inputs 1-3 in slot A (Basic I/O).

16 DIN4, DIN5, DIN6 (V1.14, V1.16)

This monitoring value shows the status of the digital inputs 4-6 in OPTA1 (Basic I/O).

17 DO1, RO1, RO2 (V1.15, V1.17)

This monitoring value shows the status of the digital output and relay outputs 1-2 in OPTA2 and OPTA3.

18 TORQUE REFERENCE (V1.18)

This monitoring value shows the final torque reference for motor control.

20 PID REFERENCE (V1.18, V1.19)

This monitoring value shows the PID reference as a percentage of the maximum frequency.

21 PID ACTUAL VALUE (V1.19, V1.20)

This monitoring value shows the PID actual value as a percentage of the maximum actual value.

22 PID ERROR VALUE (V1.20, V1.21)

This monitoring value shows the error value of the PID controller.

23 PID OUTPUT (V1.21, V1.22)

This monitoring value shows the output of the PID controller as a percentage (0-100%).

25 FREQUENCY REFERENCE (V1.2)

This monitoring value shows the actual frequency reference to the motor control.

26 ANALOGUE IOUT (V1.15, V1.16, V1.18)

This monitoring value shows the status of the analogue output 1.

27 ANALOGUE INPUT 3 (V1.13, V1.16)

This monitoring value shows the status of the analogue input 3.

28 ANALOGUE INPUT 4 (V1.14, V1.17)

This monitoring value shows the status of the analogue input 4.

29 ACTUAL SPECIAL DISPLAY (V1.23)

This monitoring value shows the actual values of parameters for special display.

30 RUNNING AUXILIARY DRIVES (V1.22)

This monitoring value shows the actual number of auxiliary drives that operate in the system.

31 ANALOGUE OUT 2 (V1.21.20)

This monitoring value shows the value of the analogue output 2 as a percentage of the used range.

32 ANALOGUE OUT 3 (V1.21.21)

This monitoring value shows the value of the analogue output 3 as a percentage of the used range.

37 FAULT HISTORY (V1.21.5, V1.22.8, V1.26.5)

This monitoring value shows the fault code of latest activated fault that is not reset.

39 U PHASE CURRENT (V1.18.5)

This monitoring value shows the measured phase current of the motor (1 s filtering).

40 V PHASE CURRENT (V1.18.6)

This monitoring value shows the measured phase current of the motor (1 s filtering).

41 W PHASE CURRENT (V1.18.7)

This monitoring value shows the measured phase current of the motor (1 s filtering).

42 SENSOR MAX TEMPERATURE (V1.19, V1.24)

This monitoring value shows the maximum temperature of the sensor.

43 STATUS WORD (V1.18.4, V1.21.4, V1.26.4)

This monitoring value shows the bit-coded status of the AC drive.

44 DC VOLTAGE (V1.18.3, V1.21.3, V1.26.3)

This monitoring value shows the unfiltered DC-voltage.

45 FB CURRENT (V1.21.6, V1.22.9, V1.26.6)

This monitoring value shows the measured current of the motor with fixed number of decimals.

46 FB LIMIT SCALING (V1.22.5)

This monitoring value shows the value of the fieldbus limit scaling as a percentage.

47 FB ADJUST REFERENCE (V1.22.6)

This monitoring value shows the value of the fieldbus adjust reference as a percentage.

48 FB ANALOG OUT (V1.22.7)

This monitoring value shows the status of analogue output controlled by fieldbus input.

49 ID RUN STATUS (V1.21.14)

This monitoring value shows the status of the identification run.

50 SENSOR 1 TEMPERATURE (V1.21.8)

This monitoring value shows the measured value of the sensor 1 temperature.

51 SENSOR 2 TEMPERATURE (V1.21.9)

This monitoring value shows the measured value of the sensor 2 temperature.

52 SENSOR 3 TEMPERATURE (V1.21.10)

This monitoring value shows the measured value of the sensor 3 temperature.

53 ENCODER 2 FREQUENCY (V1.21.11)

This monitoring value shows the encoder 2 frequency from the OPTA7 board (input C.3).

54 ABS POSITION (V1.21.12)

This monitoring value shows the ABS position when the OPTBB board is in use.

55 ABS REVOLUTION (V1.21.13)

This monitoring value shows the number of ABS revolutions when the OPTBB board is in use.

56 DIN STATUSWORD 1 (V1.22.10)

This monitoring value shows the bit-coded status of the digital input signals.

57 DIN STATUSWORD 2 (V1.22.11)

This monitoring value shows the bit-coded status of the digital input signals.

58 POLE PAIR NUMBER (V1.21.15)

This monitoring value shows the pole pair number in use.

59 AI1 (V1.21.16)

This monitoring value shows the value of the analogue input signal as a percentage of the used range.

60 AI2 (V1.21.17)

This monitoring value shows the value of the analogue input signal as a percentage of the used range.

61 AI3 (V1.21.18)

This monitoring value shows the value of the analogue input signal as a percentage of the used range.

62 AI4 (V1.21.19)

This monitoring value shows the value of the analogue input signal as a percentage of the used range.

69 SENSOR 4 TEMPERATURE (V1.21.25)

This monitoring value shows the measured value of the temperature.

70 SENSOR 5 TEMPERATURE (V1.21.26)

This monitoring value shows the measured value of the temperature.

71 SENSOR 6 TEMPERATURE (V1.21.27)

This monitoring value shows the measured value of the temperature.

74 WARNING (V1.21.7, V1.22.12)

This monitoring value shows the warning code of latest activated warning that is not reset.

83 TOTAL CURRENT (V1.32.2)

This monitoring value shows the total current of the drives in the Master Follower system.

221 FIELDBUS PROCESS DATA IN 1 (V1.22.16.1)

This monitoring value shows the raw value of process data in a 32-bit signed format.

222 FIELDBUS PROCESS DATA IN 1 (V1.22.16.2)

This monitoring value shows the raw value of process data in a 32-bit signed format.

223 FIELDBUS PROCESS DATA IN 3 (V1.22.16.3)

This monitoring value shows the raw value of process data in a 32-bit signed format.

224 FIELDBUS PROCESS DATA IN 4 (V1.22.16.4)

This monitoring value shows the raw value of process data in a 32-bit signed format.

225 FIELDBUS PROCESS DATA IN 5 (V1.22.16.5)

This monitoring value shows the raw value of process data in a 32-bit signed format.

226 FIELDBUS PROCESS DATA IN 6 (V1.22.16.6)

This monitoring value shows the raw value of process data in a 32-bit signed format.

227 FIELDBUS PROCESS DATA IN 7 (V1.22.16.7)

This monitoring value shows the raw value of process data in a 32-bit signed format.

228 FIELDBUS PROCESS DATA IN 8 (V1.22.16.8)

This monitoring value shows the raw value of process data in a 32-bit signed format.

229 FIELDBUS PROCESS DATA IN 9 (V1.22.16.9)

This monitoring value shows the raw value of process data in a 32-bit signed format.
Visible only when the option board installed in the AC drive supports 16 Process data items.

230 FIELDBUS PROCESS DATA IN 10 (V1.22.16.10)

This monitoring value shows the raw value of process data in a 32-bit signed format.
Visible only when the option board installed in the AC drive supports 16 Process data items.

231 FIELDBUS PROCESS DATA IN 11 (V1.22.16.11)

This monitoring value shows the raw value of process data in a 32-bit signed format.
Visible only when the option board installed in the AC drive supports 16 Process data items.

232 FIELDBUS PROCESS DATA IN 12 (V1.22.16.12)

This monitoring value shows the raw value of process data in a 32-bit signed format.
Visible only when the option board installed in the AC drive supports 16 Process data items.

233 FIELDBUS PROCESS DATA IN 13 (V1.22.16.13)

This monitoring value shows the raw value of process data in a 32-bit signed format.
Visible only when the option board installed in the AC drive supports 16 Process data items.

234 FIELDBUS PROCESS DATA IN 14 (V1.22.16.14)

This monitoring value shows the raw value of process data in a 32-bit signed format.
Visible only when the option board installed in the AC drive supports 16 Process data items.

235 FIELDBUS PROCESS DATA IN 15 (V1.22.16.15)

This monitoring value shows the raw value of process data in a 32-bit signed format.
Visible only when the option board installed in the AC drive supports 16 Process data items.

236 FIELDBUS PROCESS DATA IN 16 (V1.22.16.16)

This monitoring value shows the raw value of process data in a 32-bit signed format.
Visible only when the option board installed in the AC drive supports 16 Process data items.

237 FIELDBUS PROCESS DATA OUT 1 (V1.22.16.17)

This monitoring value shows the raw value of process data in a 32-bit signed format.

238 FIELDBUS PROCESS DATA OUT 2 (V1.22.16.18)

This monitoring value shows the raw value of process data in a 32-bit signed format.

239 FIELDBUS PROCESS DATA OUT 3 (V1.22.16.19)

This monitoring value shows the raw value of process data in a 32-bit signed format.

240 FIELDBUS PROCESS DATA OUT 4 (V1.22.16.20)

This monitoring value shows the raw value of process data in a 32-bit signed format.

241 FIELDBUS PROCESS DATA OUT 5 (V1.22.16.21)

This monitoring value shows the raw value of process data in a 32-bit signed format.

242 FIELDBUS PROCESS DATA OUT 6 (V1.22.16.22)

This monitoring value shows the raw value of process data in a 32-bit signed format.

243 FIELDBUS PROCESS DATA OUT 7 (V1.22.16.23)

This monitoring value shows the raw value of process data in a 32-bit signed format.

244 FIELDBUS PROCESS DATA OUT 8 (V1.22.16.24)

This monitoring value shows the raw value of process data in a 32-bit signed format.

245 FIELDBUS PROCESS DATA OUT 9 (V1.22.16.25)

This monitoring value shows the raw value of process data in a 32-bit signed format.
Visible only when the option board installed in the AC drive supports 16 Process data items.

246 FIELDBUS PROCESS DATA OUT 10 (V1.22.16.26)

This monitoring value shows the raw value of process data in a 32-bit signed format.
Visible only when the option board installed in the AC drive supports 16 Process data items.

247 FIELDBUS PROCESS DATA OUT 11 (V1.22.16.27)

This monitoring value shows the raw value of process data in a 32-bit signed format.
Visible only when the option board installed in the AC drive supports 16 Process data items.

248 FIELDBUS PROCESS DATA OUT 12 (V1.22.16.28)

This monitoring value shows the raw value of process data in a 32-bit signed format.
Visible only when the option board installed in the AC drive supports 16 Process data items.

249 FIELDBUS PROCESS DATA OUT 13 (V1.22.16.29)

This monitoring value shows the raw value of process data in a 32-bit signed format.
Visible only when the option board installed in the AC drive supports 16 Process data items.

250 FIELDBUS PROCESS DATA OUT 14 (V1.22.16.30)

This monitoring value shows the raw value of process data in a 32-bit signed format.
Visible only when the option board installed in the AC drive supports 16 Process data items.

251 FIELDBUS PROCESS DATA OUT 15 (V1.22.16.31)

This monitoring value shows the raw value of process data in a 32-bit signed format. Visible only when the option board installed in the AC drive supports 16 Process data items.

252 FIELDBUS PROCESS DATA OUT 16 (V1.22.16.32)

This monitoring value shows the raw value of process data in a 32-bit signed format. Visible only when the option board installed in the AC drive supports 16 Process data items.

865 FIELDBUS ACTUAL SPEED (V1.22.3)

This monitoring value shows the actual speed of the motor sent to the fieldbus.

875 FIELDBUS SPEED REFERENCE (V1.22.2)

This monitoring value shows the speed reference from the fieldbus.

1113 CURRENT (V1.18.1, V1.21.1, V1.26.1)

This monitoring value shows the unfiltered motor current.

1124 ENCODER 1 FREQUENCY (V1.21.5)

This monitoring value shows the input frequency of the encoder.

1125 TORQUE (V1.18.2, V1.21.2, V1.26.2)

This monitoring value shows the unfiltered motor torque.

1131 FINAL FREQUENCY REFERENCE CL (V1.21.22)

This monitoring value shows the final shaft frequency reference for the speed controller.

1132 STEP RESPONSE (V1.21.23)

This monitoring value shows the response for the frequency ramp step.

1140 FB TORQUE REFERENCE (V1.22.4)

This monitoring value shows the fieldbus torque reference.

1160 FIELDBUS CONTROL WORD (V1.22.1)

This monitoring value shows the status of the fieldbus control word that the application uses in bypass mode.

Depending on the fieldbus type or profile, the data that is received from the fieldbus can be modified before it is sent to the application.

Table 105: Fieldbus Control Word (ProfiDrive)

Bit	Descriptions	
	Value = 0 (FALSE)	Value = 1 (TRUE)
Bit 0	OFF	ON, Reset after Fault or b1 and b2
Bit 1	Emergency stop by coast	ON, On normal operation: Keep TRUE
Bit 2	Emergency stop by ramp	ON, On normal operation: Keep TRUE
Bit 3	STOP REQUEST	RUN REQUEST
Bit 4	Force ramp to Zero	Enable Ramp
Bit 5	Freeze Ramp	Enable Ramp
Bit 6	Force Ref to Zero	Enable Ramp
Bit 7	No action	FAULT RESET (0 -> 1)
Bit 8	No action	Inching 1
Bit 9	No action	Inching 2
Bit 10	Disable Profibus control	Enable Profibus control
Bit 11	Fieldbus DIN1=OFF	Fieldbus DIN1=ON
Bit 12	Fieldbus DIN2=OFF	Fieldbus DIN2=ON
Bit 13	Fieldbus DIN3=OFF	Fieldbus DIN3=ON
Bit 14	Fieldbus DIN4=OFF	Fieldbus DIN4=ON
Bit 15	No Action	No Action

1169 SHAFT ANGLE (V1.21.7)

This monitoring value shows the shaft angle from the encoder.

1170 SHAFT ROUNDS (V1.21.6)

This monitoring value shows the shaft rounds from the encoder.

1172 FAULT WORD 1 (V1.22.13)

This monitoring value shows the bit-coded status of the Fault Word 1.

1173 FAULT WORD 2 (V1.22.14)

This monitoring value shows the bit-coded status of the Fault Word 2.

1174 ALARM WORD 1 (V1.22.15)

This monitoring value shows the bit-coded status of the Alarm Word.

1508 OUTPUT POWER (V1.21.24)

This monitoring value shows the output power.

1601 SB SYSTEMSTATUS (V1.23.1)

This monitoring value shows the status of the SystemBus.

1602 STATUS WORD (V1.23.4.2)

This monitoring value shows the status of the Status Word of the Follower drive.

1603 STATUS WORD D3 (V1.23.4.3)

This monitoring value shows the status of the Status Word of the Follower drive.

1604 STATUS WORD D4 (V1.23.4.4)

This monitoring value shows the status of the Status Word of the Follower drive.

1605 MOTOR CURRENT D2 (V1.23.3.2)

This monitoring value shows the measured current of the motor.

1606 MOTOR CURRENT D3 (V1.23.3.3)

This monitoring value shows the measured current of the motor.

1607 MOTOR CURRENT D4 (V1.23.3.4)

This monitoring value shows the measured current of the motor.

1615 STATUS WORD 1 (V1.23.4.1)

This monitoring value shows the status of the Status Word of the Follower drive.

1616 MOTOR CURRENT D1 (V1.23.3.1)

This monitoring value shows the measured current of the motor.

9 PARAMETER DESCRIPTIONS

On the following pages you find the parameter descriptions arranged according to the individual ID number of the parameter. An asterisk after the parameter ID number (e.g. 418 Motor potentiometer UP *) indicates that the TTF programming method must be applied to this parameter (see Chapter 9.9 "Terminal to function" (TTF) programming principle).

Some parameter names are followed by a number code indicating the "All in One" applications in which the parameter is included. If no code is shown the parameter is available in all applications. See below. The parameter numbers under which the parameter appears in different applications are also given.

1. Basic Application
2. Standard Application
3. Local/Remote Control Application
4. Multi-Step Speed Control Application
5. PID Control Application
6. Multi-Purpose Control Application
7. Pump and Fan Control Application

101 MINIMUM FREQUENCY (2.1, 2.1.1)

Use this parameter to set the minimum frequency reference.

102 MAXIMUM FREQUENCY (2.2, 2.1.2)

Use this parameter to set the maximum frequency reference.

Defines the frequency limits of the AC drive. The maximum value for these parameters is 320 Hz.

Minimum and maximum frequencies set limits to other frequency related parameters (e.g. Preset Speed 1 (ID105), Preset Speed 2 (ID106) and 4 mA fault preset speed (ID728)).

103 ACCELERATION TIME 1 (2.3, 2.1.3)

Use this parameter to set the time that is necessary for the output frequency to increase from zero frequency to maximum frequency.

104 DECELERATION TIME 1 (2.4, 2.1.4)

Use this parameter to set the time that is necessary for the output frequency to decrease from maximum frequency to zero frequency.

105 PRESET SPEED 1 1246 (2.18, 2.1.14, 2.1.15)

Use this parameter to set the preset frequency reference when the preset frequencies function is used.

106 PRESET SPEED 2 1246 (2.19, 2.1.15, 2.1.16)

Use this parameter to set the preset frequency reference when the preset frequencies function is used.

These parameters can be used to determine frequency references that are applied when the appropriate digital inputs are activated

Parameter values are automatically limited to the maximum frequency (ID102).

**NOTE!**

The use of TTF-programming method in the Multi-purpose Control Application. Because all digital inputs are programmable you first have to assign two DINs for the Preset Speed functions (parameters ID419 and ID420).

Table 106: Preset speed

Speed	Preset speed 1 (DIN4/ID419)	Preset speed 2 (DIN5/ID420)
Basic reference	0	0
ID105	1	0
ID106	0	1

107 CURRENT LIMIT (2.5, 2.1.5)

Use this parameter to set the maximum motor current from the AC drive.

The range of values for the parameter is different for each enclosure size of the drive. When the current limit is changed the stall current limit (ID710) is internally calculated to 90% of current limit.

When the current limit is active, the drive output frequency decreases.

**NOTE!**

The Current Limit is not an overcurrent trip limit.

108 U/F RATIO SELECTION 234567 (2.6.3)

Use this parameter to set the type of the U/f curve between zero frequency and the field weakening point.

Table 107: Selections for parameter ID108

Selection number	Selection name	Description
0	Linear	The voltage of the motor changes linearly as a function of the output frequency. The voltage changes from the value of Zero Frequency Voltage (ID606) to the value of Voltage at Field Weakening Point (ID603) at a frequency set in Field Weakening Point Frequency (ID602). Use this default setting if a different setting is not necessary.
1	Squared	The voltage of the motor changes from the value of Zero Frequency Voltage (ID606) to the value of Field Weakening Point Frequency (ID603) at a squared curve. The motor operates undermagnetised below the field weakening point and produces less torque. You can use the squared U/f ratio in applications where the torque demand is in relation to the square of the speed, for example in centrifugal fans and pumps. See <i>Fig. 24</i> .
2	Programmable	It is possible to program the U/f curve with 3 different points: the zero frequency voltage (P1), the midpoint voltage/frequency (P2), and the field weakening point (P3). You can use the programmable U/f curve at low frequencies if it is necessary to have more torque. You can find the optimal settings automatically with an identification run (ID631). See <i>Fig. 25</i> .
3	Linear with flux optimisation	The AC drive starts to search for the minimum motor current in order to save energy and to lower the motor noise. This function can be used in applications such as fans, pumps etc.

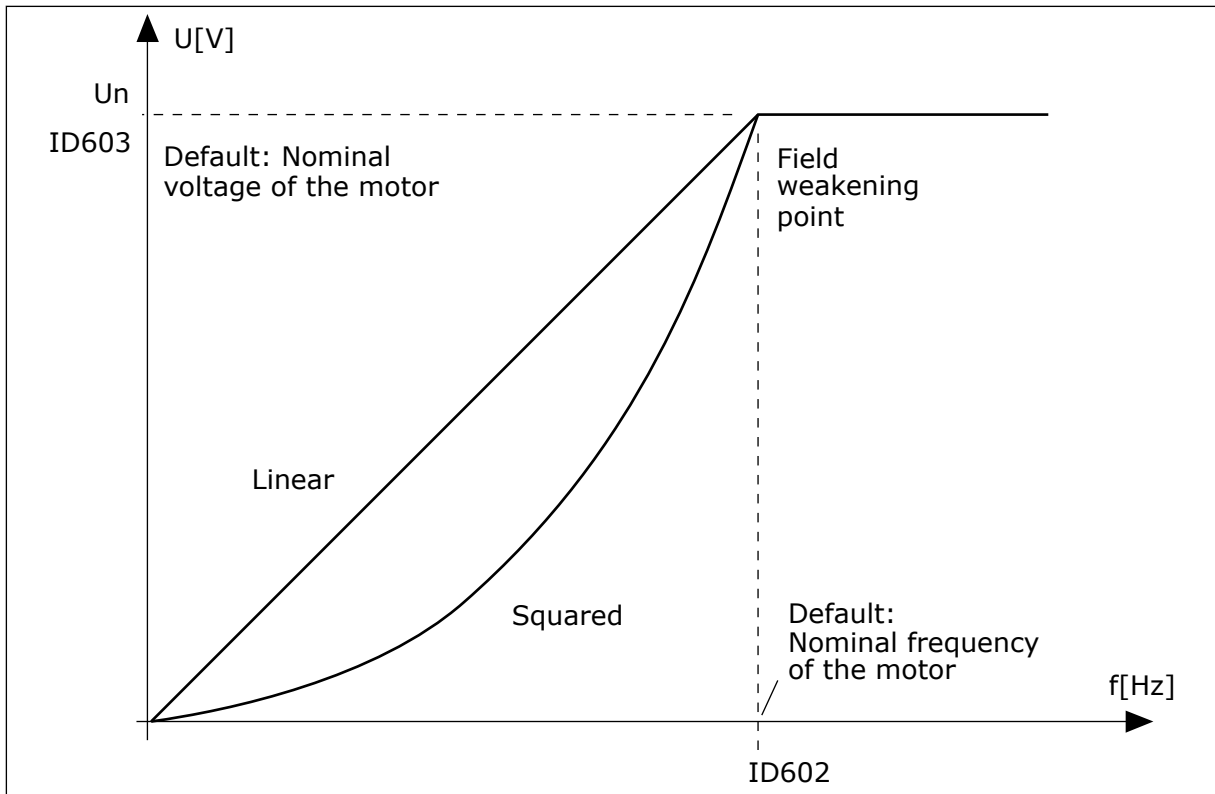

Fig. 24: Linear and squared change of the motor voltage

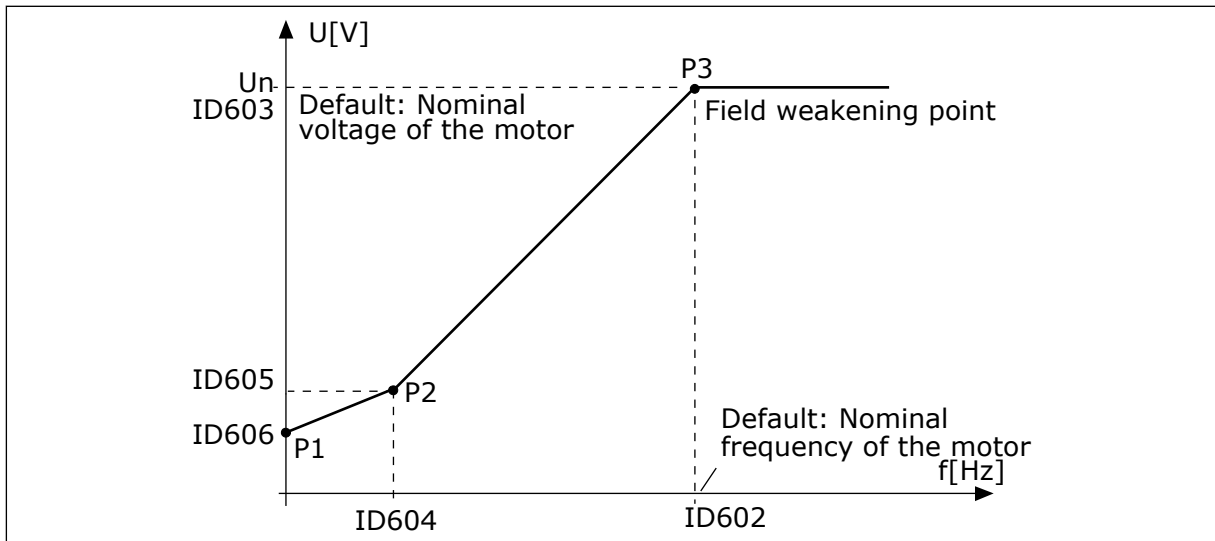

Fig. 25: The programmable U/f curve

109 U/F OPTIMISATION (2.13, 2.6.2)

Use this parameter to set the U/f optimization.

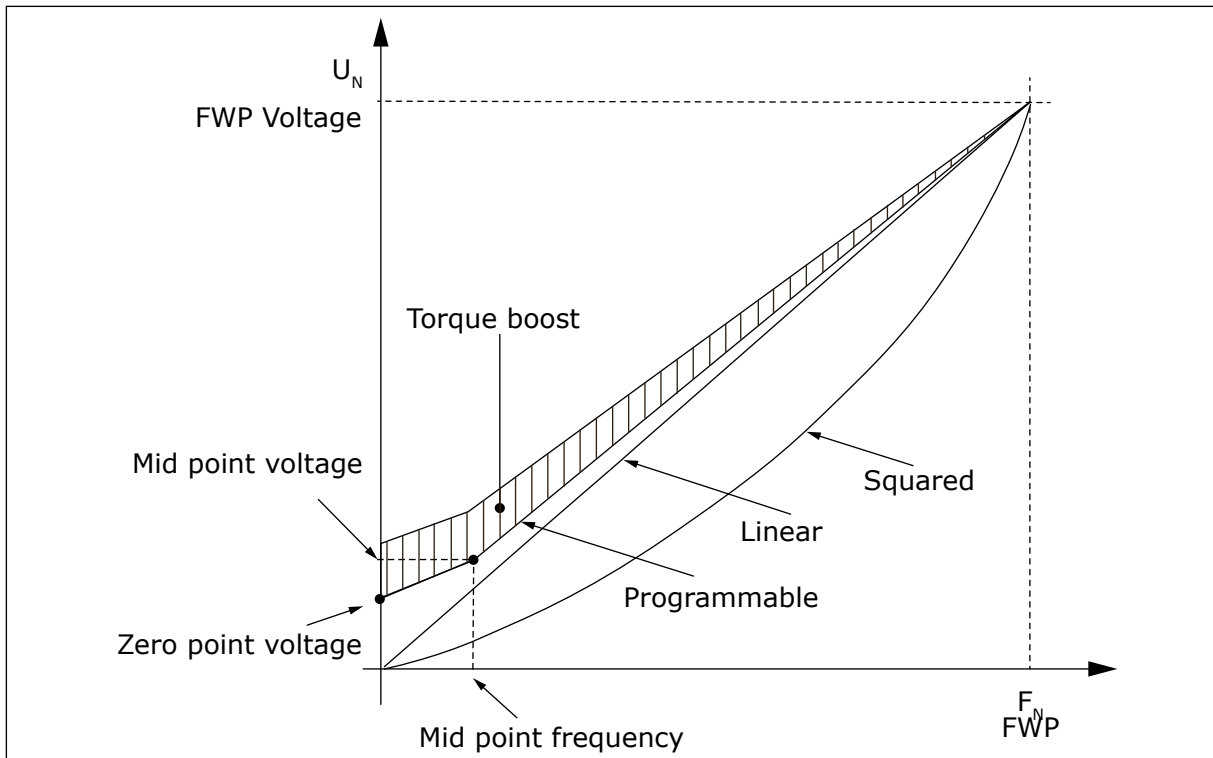

Fig. 26: U/f optimisation

The voltage to the motor changes in proportion to required torque which makes the motor produce more torque at start and when running at low frequencies. Automatic torque boost can be used in applications where starting torque due to starting friction is high, for example, in conveyors.

To start with high torque from 0 Hz, set the motor nominal values (Parameter group 2.1) either automatically or manually.

Setting the motor nominal values with automatic functions

1. Make identification run (ID631) with rotating motor.
2. If needed, activate the speed control or U/f optimization (Torque boost).
3. If needed, activate both the speed control and U/f optimization.

Setting the motor nominal values by manual tuning

1. Set the motor magnetizing current:
 1. Run the motor using 2/3 of motor nominal frequency as the frequency reference.
 2. Read the motor current in the monitoring menu or use NCDrive for monitoring.
 3. Set this current as the motor magnetizing current (ID612).
2. Set the U/f ration selection (ID108) to value 2 (programmable U/f curve).
3. Run the motor with zero frequency reference and increase the motor zero point voltage (ID606) until the motor current is approximately same as the motor magnetising current. If the motor is in a low frequency area for only short periods, it is possible to use up to 65% of the motor nominal current.
4. Set the midpoint voltage (ID605) to $1.4142 \cdot ID606$ and midpoint frequency (ID604) to value $ID606/100\% \cdot ID111$.
5. If needed, activate the speed control or U/f optimization (Torque boost).
6. If needed, activate both the speed control and U/f optimization.



NOTE!

In high torque – low speed applications – it is likely that the motor will overheat. If the motor has to run a prolonged time under these conditions, special attention must be paid to cooling the motor. Use external cooling for the motor if the temperature tends to rise too high.

110 NOMINAL VOLTAGE OF THE MOTOR (2.6, 2.1.6)

Find the value U_n on the nameplate of the motor.

This parameter sets the voltage at the field weakening point (ID603) to $100\% \cdot U_{nMotor}$.



NOTE!

Find out if the motor connection is Delta or Star.

111 NOMINAL FREQUENCY OF THE MOTOR (2.7, 2.1.7)

Find the value f_n on the nameplate of the motor.

This parameter sets the field weakening point (ID602) to the same value.

112 NOMINAL SPEED OF THE MOTOR (2.8, 2.1.8)

Find the value n_n on the nameplate of the motor.

113 NOMINAL CURRENT OF THE MOTOR (2.9, 2.1.9)

Find the value I_n on the nameplate of the motor.

If magnetization current is provided set also parameter ID612 before making the Identification run (NXP only)

114 STOP BUTTON ACTIVATED (3.4, 3.6)

Use this parameter to enable the keypad stop button.

If you wish to make the Stop button a "hotspot" which always stops the drive regardless of the selected control place, give this parameter the value 1.

See also parameter ID125.

117 I/O FREQUENCY REFERENCE SELECTION 12346 (2.14, 2.1.11)

Use this parameter to select the reference source when the control place is I/O A.

Table 108: Selections for parameter ID117

Applic.	1 to 4	6
Sel.		
0	Analogue input 1 (AI1)	Analogue input 1 (AI1). See ID377
1	Analogue input 2 (AI2).	Analogue input 2 (AI2). See ID388
2	Keypad reference (Menu M3)	AI1+AI2
3	Fieldbus reference	AI1-AI2
4	Potentiometer reference (Application 3 only)	AI2-AI1
5		AI1*AI2
6		AI1 joystick
7		AI2 joystick
8		Keypad reference (Menu M3)
9		Fieldbus reference
10		Potentiometer reference; controlled with ID418 (TRUE=increase) and ID417 (TRUE=decrease)
11		AI1 or AI2, whichever is lower
12		AI1 or AI2, whichever is greater
13		Max. frequency (recommended in torque control only)
14		AI1/AI2 selection, see ID422
15		Encoder 1 (AI input C.1)
16		Encoder 2 (With OPTA7 Speed Synchronization, NXP only) (AI input C.3)

118 PID CONTROLLER GAIN 57 (2.1.12)

Use this parameter to adjust the gain of the PID controller.

If the value of the parameter is set to 100%, a change of 10% in the error value causes the controller output to change by 10%. If the parameter value is set to 0 the PID controller operates as ID controller.

For examples, see ID132.

119 PID CONTROLLER I-TIME 57 (2.1.13)

Use this parameter to adjust the integration time of the PID controller.

If this parameter is set to 1.00 s, a change of 10% in the error value causes the controller output to change by 10.00%/s. If the parameter value is set to 0.00 s, the PID controller will operate as PD controller.

For examples, see ID132.

120 MOTOR COS PHI (2.10, 2.1.10)

Find the value on the nameplate of the motor.

121 KEYPAD FREQUENCY REFERENCE SELECTION 234567 (2.1.12, 2.1.13, 2.2.6, 2.2.1.2)

Use this parameter to select the reference source when the control place is keypad.

Table 109: Selection for parameter ID121

Appl.	2-4	5	6	7
Sel.				
0	Analogue input 1 (AI1)	Analogue input 1 (AI1)	Analogue input 1 (AI1)	Analogue input 1 (AI1)
1	Analogue Input 2 (AI2)	Analogue Input 2 (AI2)	Analogue Input 2 (AI2)	Analogue Input 2 (AI2)
2	Keypad reference (Menu M3)	AI3	AI1+AI2	AI3
3	Fieldbus reference*	AI4	AI1-AI2	AI4
4		Keypad reference (Menu M3)	AI2-AI1	Keypad reference (Menu M3)
5		Fieldbus reference*	AI1*AI2	Fieldbus reference*
6		Potentiometer ref.	AI1 joystick	Potentiometer ref.
7		PID controller ref.	AI2 joystick	PID controller ref.
8			Keypad reference (Menu M3)	
9			Fieldbus reference*	

*FBSpeedReference. For more information, see the used fieldbus manual.

122 FIELDBUS FREQUENCY REFERENCE SELECTION 234567 (2.1.13, 2.1.14, 2.2.7, 2.2.1.3)

Use this parameter to select the reference source when the control place is Fieldbus.
For selections in different applications, see ID121.

123 KEYPAD DIRECTION (3.3)

Use this parameter to set the rotation direction of the motor when the control place is keypad.

Table 110: Selections for parameter ID123

Selection number	Selection name	Description
0	Forward	The rotation of the motor is forward, when the keypad is the active control place.
1	Reverse	The rotation of the motor is reversed, when the keypad is the active control place.

For more information, see the product's User manual.

124 JOGGING SPEED REFERENCE 34567 (2.1.14, 2.1.15, 2.1.19)

Use this parameter to set the jogging frequency reference when the jogging speed function is in use.

Defines the jogging speed reference when activated by digital input. See parameter ID301 and ID413.

The parameter value is automatically limited to Maximum frequency (ID102).

125 CONTROL PLACE (3.1)

Use this parameter to select the control place.

For more information, see the product's User manual.

Pushing the Start button for 3 seconds selects the control keypad as the active control place and copies the Run status information (Run/Stop, direction and reference).

Table 111: Selections for parameter ID125

Selection number	Selection name	Description
0	PC Control, (activated by NCDrive)	
1	I/O terminal	
2	Keypad	
3	Fieldbus	

126 PRESET SPEED 3 46 (2.1.17)

Use this parameter to set the preset speed reference when the preset speed function is used.

127 PRESET SPEED 4 46 (2.1.18)

Use this parameter to set the preset speed reference when the preset speed function is used.

128 PRESET SPEED 5 46 (2.1.19)

Use this parameter to set the preset speed reference when the preset speed function is used.

129 PRESET SPEED 6 46 (2.1.20)

Use this parameter to set the preset speed reference when the preset speed function is used.

130 PRESET SPEED 7 46 (2.1.21)

Use this parameter to set the preset speed reference when the preset speed function is used.

These parameters can be used to determine frequency references that are applied when appropriate combinations of digital inputs are activated.

In Multi-Step Speed Application (Application 4), digital inputs DIN4, DIN5 and DIN6 are assigned to Preset Speed functions. The combinations of these activated inputs select the preset speed reference.

**NOTE!**

The use of TTF-programming method in the Multi-purpose Control Application. Because all digital inputs are programmable you first have to assign three DINs for the Preset Speed functions (parameters ID41, ID420 and ID421).

Table 112: Preset speeds 1 to 7

Speed	DIN4/ID419	DIN5/ID420	DIN6/ID421
Basic speed	0	0	0
Preset speed 1 (ID105)	1	0	0
Preset speed 2 (ID106)	0	1	0
Preset speed 3 (ID126)	1	1	0
Preset speed 4 (ID127)	0	0	1
Preset speed 5 (ID128)	1	0	1
Preset speed 6 (ID129)	0	1	1
Preset speed 7 (ID130)	1	1	1

See also parameters ID105 and ID106.

Parameter value is automatically limited to maximum frequency (ID102).

131 I/O FREQUENCY REFERENCE SELECTION, PLACE B3 (2.1.12)

Use this parameter to select the reference source when the control place is I/O B.

See the values of the parameter ID117 above.

132 PID CONTROLLER D-TIME 57 (2.1.14)

Use this parameter to adjust the derivation time of the PID controller.

If this parameter is set to 1.00 second a change of 10% in the error value during 1.00 s causes the controller output to change by 10.00%. If the parameter value is set to 0.00 s the PID controller will operate as PI controller.

See examples below.

EXAMPLE 1:

In order to reduce the error value to zero, with the given values, the AC drive output behaves as follows:

Given values:

P2.1.12, P = 0%

P2.1.13, I-time = 1.00 s

P2.1.14, D-time = 0.00 s Min freq. = 0 Hz

Error value (setpoint – process value) = 10.00% Max freq. = 50 Hz

In this example, the PID controller operates practically as I-controller only.

According to the given value of parameter 2.1.13 (I-time), the PID output increases by 5 Hz (10% of the difference between the maximum and minimum frequency) every second until the error value is 0.

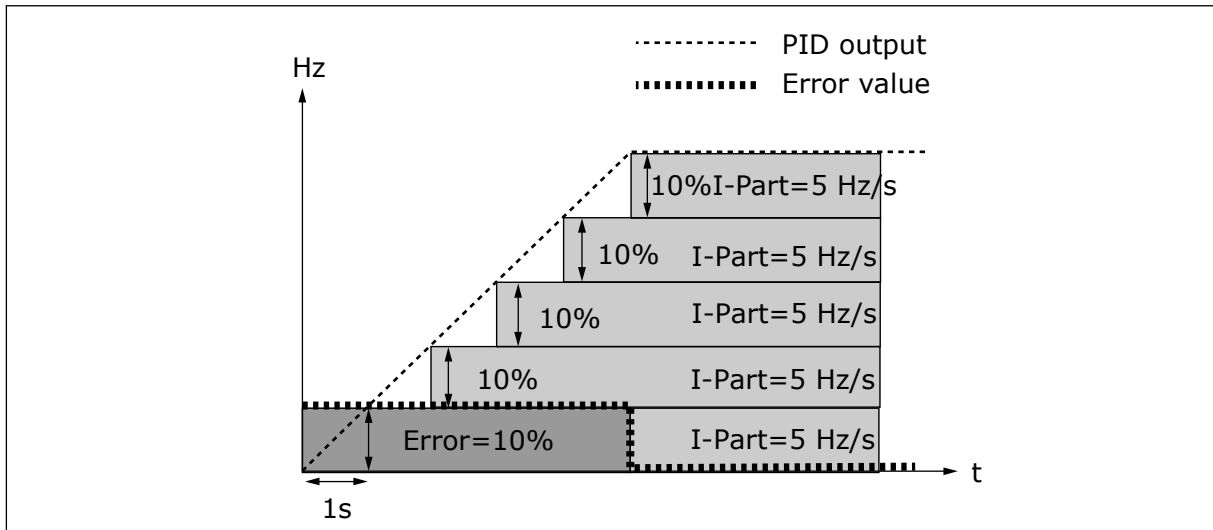

Fig. 27: PID controller function as I-controller

EXAMPLE 2

Given values:

P2.1.12, P = 100%

P2.1.13, I-time = 1.00 s

P2.1.14, D-time = 1.00 s Min freq. = 0 Hz

Error value (setpoint - process value) = $\pm 10\%$ Max freq. = 50 Hz

As the power is switched on, the system detects the difference between the setpoint and the actual process value and starts to either raise or decrease (in case the error value is negative) the PID output according to the I-time. Once the difference between the setpoint and the process value has been reduced to 0 the output is reduced by the amount corresponding to the value of parameter 2.1.13.

In case the error value is negative, the AC drive reacts reducing the output correspondingly.

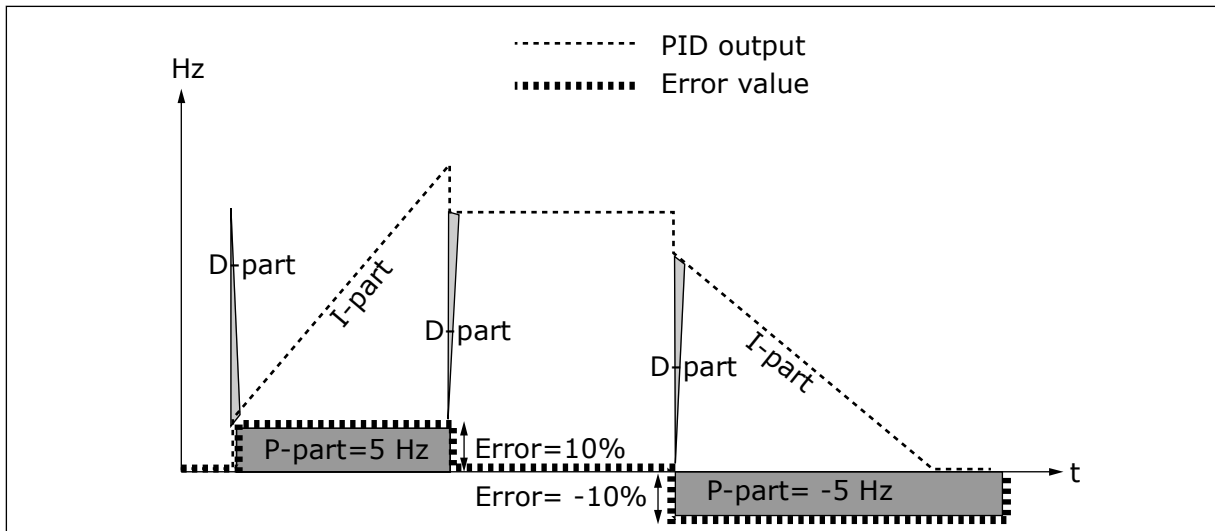

Fig. 28: PID output curve with the values of Example 2

EXAMPLE 3

Given values:

P2.1.12, P = 100%

P2.1.13, I-time = 0.00 s

P2.1.14, D-time = 1.00 sMin freq. = 0 Hz

Error value (setpoint – process value) = ±10%/sMax freq. = 50 Hz

As the error value increases, also the PID output increases according to the set values (D-time = 1.00s).

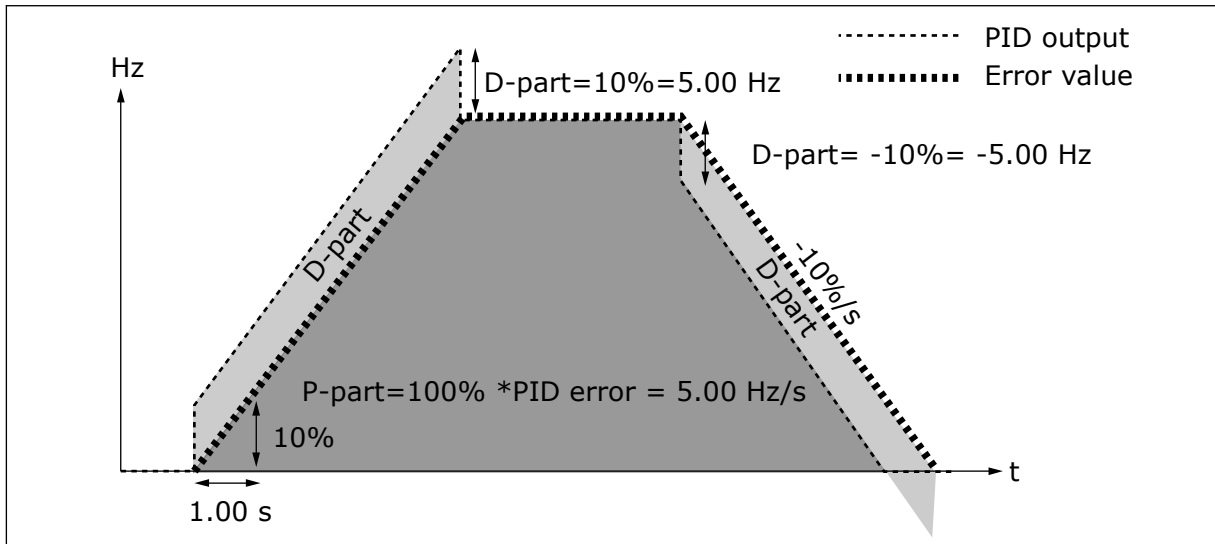

Fig. 29: PID output with the values of Example 3

133 PRESET SPEED 8 4 (2.1.22)

Use this parameter to set the preset speed reference when the preset speed function is used.

134 PRESET SPEED 9 4 (2.1.23)

Use this parameter to set the preset speed reference when the preset speed function is used.

135 PRESET SPEED 10 4 (2.1.24)

Use this parameter to set the preset speed reference when the preset speed function is used.

136 PRESET SPEED 11 4 (2.1.25)

Use this parameter to set the preset speed reference when the preset speed function is used.

137 PRESET SPEED 12 4 (2.1.26)

Use this parameter to set the preset speed reference when the preset speed function is used.

138 PRESET SPEED 13 4 (2.1.27)

Use this parameter to set the preset speed reference when the preset speed function is used.

139 PRESET SPEED 14 4 (2.1.28)

Use this parameter to set the preset speed reference when the preset speed function is used.

140 PRESET SPEED 15 4 (2.1.29)

Use this parameter to set the preset speed reference when the preset speed function is used.

To use these preset speeds in the Multi-Step Speed Application (ASFIF04), parameter ID301 must be given the value 13. In Multi-Step Speed Application (Application 4), digital inputs DIN4, DIN5 and DIN6 are assigned to Preset Speed functions. The combinations of these activated inputs select the preset speed reference.

Table 113: Multi-step speed selections with digital inputs DIN3, DIN4, DIN5 and DIN6

Speed	Multi-step speed sel. 1 (DIN4)	Multi-step speed sel. 2 (DIN5)	Multi-step speed sel. 3 (DIN6)	Multi-step speed sel. 4 (DIN3)
P2.1.22 (8)	0	0	0	1
P2.1.23 (9)	1	0	0	1
P2.1.24 (10)	0	1	0	1
P2.1.25 (11)	1	1	0	1
P2.1.26 (12)	0	0	1	1
P2.1.27 (13)	1	0	1	1
P2.1.28 (14)	0	1	1	1
P2.1.29 (15)	1	1	1	1

141 AI3 SIGNAL SELECTION * 567 (2.2.38, 2.2.4.1)

Use this parameter to connect the AI signal to the analogue input of your choice.

Connect the AI3 signal to the analogue input of your choice with this parameter. For more information, see Chapter 9.9 "Terminal to function" (TTF) programming principle.

**NOTE!**

If you use an NXP drive and the Multi-Purpose Control Application (Application 6), you can control AI3 from fieldbus when this input is set the value 0.1.

142 AI3 SIGNAL FILTER TIME 567 (2.2.41, 2.2.4.2)

Use this parameter to filter out disturbances in the analogue input signal.

When this parameter is given a value greater than 0.0 the function that filters out disturbances from the incoming analogue signal is activated.

Long filtering time makes the regulation response slower. See parameter ID324.

143 AI3 SIGNAL RANGE 567 (2.2.39, 2.2.4.3)

Use this parameter to change the range of the analogue signal.

With this parameter you can select the AI3 signal range.

Table 114: Selection for parameter ID143

Applic.	5	6	7
Sel.			
0	0-100%	0-100%	0-100%
1	4 mA/20-100%	4 mA/20-100%	4 mA/20-100%
2		-10...+10V	Customised
3		Customised	

144 AI3 CUSTOM SETTING MINIMUM 67 (2.2.4.4)

Use this parameter to adjust the scaling of the analogue input signal between -160%...160% freely.

145 AI3 CUSTOM SETTING MAXIMUM 67 (2.2.4.5)

Use this parameter to adjust the scaling of the analogue input signal between -160%...160% freely.

Set the custom minimum and maximum levels for the AI3 signal within - 160...160%.

Example: Min 40%, Max 80% = 8-16 mA.

151 AI3 SIGNAL INVERSION 567 (2.2.40, 2.2.4.6)

Use this parameter to invert the analogue input signal.

Table 115: Selections for parameter ID151

Selection number	Selection name	Description
0	No inversion	
1	Signal inverted	

152 AI4 SIGNAL SELECTION * 567 (2.2.42, 2.2.5.1)

Use this parameter to connect the AI signal to the analogue input of your choice.

See ID141.

153 AI4 FILTER TIME 567 (2.2.45, 2.2.5.2)

Use this parameter to filter out disturbances in the analogue input signal.

See ID142.

154 AI4 SIGNAL RANGE 567 (2.2.43, 2.2.5.3)

Use this parameter to change the range of the analogue signal.

See ID143.

155 AI4 CUSTOM SETTING MINIMUM 67 (2.2.5.3, 2.2.5.4)

Use this parameter to adjust the scaling of the analogue input signal between -160%...160% freely.

156 AI4 CUSTOM SETTING MAXIMUM * 67 (2.2.5.4, 2.2.5.5)

Use this parameter to adjust the scaling of the analogue input signal between -160%...160% freely.

See IDs 144 and 145.

162 AI4 SIGNAL INVERSION 567 (2.2.44, 2.2.5.5, 2.2.5.6)

Use this parameter to invert the analogue input signal.

See ID151.

164 MOTOR CONTROL MODE 1/2 6 (2.2.7.22)

Use this parameter to set the motor control mode 1 or 2.

Contact is open (oc) = Motor control mode 1 is selected

Contact is closed (cc) = Motor control mode 2 is selected

See parameter IDs 600 and 521.

Change from open loop to closed loop control modes and vice versa can only be made in stop state.

165 AI1 JOYSTICK OFFSET 6 (2.2.2.11)

Use this parameter to set the frequency zero point. Find the parameter, set the potentiometer at the assumed zero point and press Enter on the keypad.

**NOTE!**

This will not, however, change the reference scaling.

Press Reset button to change the parameter value back to 0.00%.

166 AI2 JOYSTICK OFFSET 6 (2.2.3.11)

Use this parameter to set the frequency zero point. Find the parameter, set the potentiometer at the assumed zero point and press Enter on the keypad.

See parameter ID165.

167 PID REFERENCE 1 57 (3.4)

Use this parameter to set the reference value of the PID controller.

The PID controller keypad reference can be set between 0% and 100%. This reference value is the active PID reference if parameter ID332 = 2.

168 PID REFERENCE 2 57 (3.5)

Use this parameter to set the reference value of the PID controller.

The PID controller keypad reference 2 can be set between 0% and 100%. This reference is active if the DIN5 function = 13 and the DIN5 contact is closed.

169 FIELD BUS DIN4 (FBFIXEDCONTROLWORDK, BIT 6) 6 (2.3.3.27)

Use this parameter to connect the Fieldbus signal (FBFixedControlWord) to the digital input of your choice.

170 FIELD BUS DIN 5 (FBFIXEDCONTROLWORD, BIT 7) 6 (2.3.3.28)

Use this parameter to connect the Fieldbus signal (FBFixedControlWord) to the digital input of your choice.

See the used fieldbus manual for more details.

179 SCALING OF MOTORING POWER LIMIT 6 (2.2.6.7)

Use this parameter to set limit to the maximum motor power.

The motoring power limit is equal to ID1289 if value 0 'Not used' is selected. If any of the inputs is selected the motoring power limit is scaled between zero and parameter ID1289. This parameter is available for NXP closed loop control mode only.

Table 116: Selections for parameter ID179

Selection number	Selection name	Description
0	Not used	
1	AI1	
2	AI2	
3	AI3	
4	AI4	
5	FB Limit Scaling ID46 (monitoring value)	

214 ACTIVE FILTER FAULT INPUT 6 (2.2.7.33)

Use this parameter to enable Active Filter Fault.

This parameter selects the digital input which triggers active filter fault/warning according to param. ID776. If the contact is closed, the response defined by parameter ID776 is triggered.

This parameter is present in NXP drives only.

**NOTE!**

This input is configured as normally open. If a normally closed input is needed, consider using external fault.

300 START/STOP LOGIC SELECTION 2346 (2.2.1, 2.2.1.1)

Use this parameter to control the start and stop of the drive with the digital signals.

Table 117: Selections for parameter ID300

Selection	DIN1	DIN2	DIN3
0	closed contact = start forward	closed contact = start reverse	
	See Fig. 30.		
1	closed contact = startopen contact = stop	closed contact = reverseopen contact = forward	
	See Fig. 31.		
2	closed contact = startopen contact = stop	closed contact = start enable- dopen contact = start disabled and drive stopped if running	can be programmed for reverse command
3 *	closed contact = start pulse	open contact = stop pulse	can be programmed for reverse command
	See Fig. 32.		
Applications 2 and 4:			
4	closed contact = start forward (Rising edge required to start)	closed contact = start reverse (Rising edge required to start)	
5	closed contact = start (Rising edge required to start) open contact = stop	closed contact = reverse open contact = forward	
6	closed contact = start (Rising edge required to start) open contact = stop	closed contact = start enabled open contact = start disabled and drive stopped if running	can be programmed for reverse command unless selected for DIN2
Applications 3 and 6:			
4	closed contact = start forward	closed contact = reference increases (motor potentiome- ter reference; this parameter is automatically set to 4 if parameter ID117 is set to 4 [Application 4]).	
5	closed contact = start forward (Rising edge required to start)	closed contact = start reverse (Rising edge required to start)	
6	closed contact = start (Rising edge required to start) open contact = stop	closed contact = reverse open contact = forward	

Table 117: Selections for parameter ID300

Selection	DIN1	DIN2	DIN3
7	closed contact = start (Rising edge required to start) open contact = stop	closed contact = start enabled open contact = start disabled and drive stopped if running	
Application 3:			
8	closed contact = start forward (Rising edge required to start)	closed contact = reference increases (motor potentiometer reference)	

* = 3-wire connection (pulse control)

The selections including the text 'Rising edge required to start' must be used to exclude the possibility of an unintentional start when, for example, power is connected, re-connected after a power failure, after a fault reset, after the drive is stopped by Run Enable (Run Enable = False) or when the control place is changed from I/O control. The Start/Stop contact must be opened before the motor can be started.

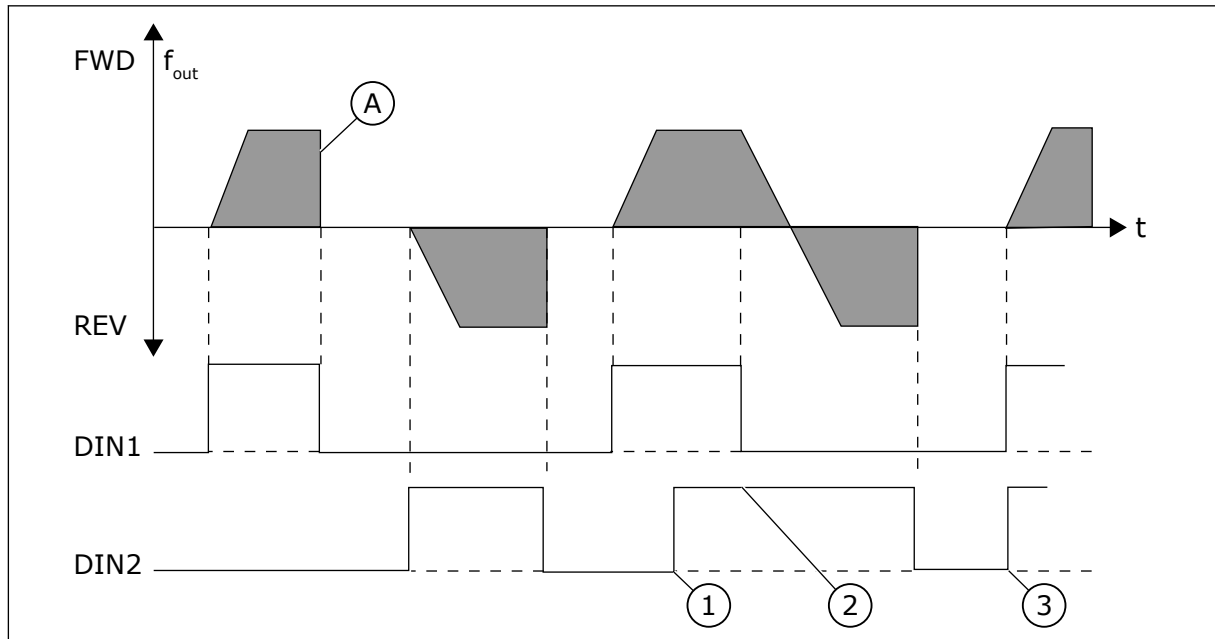

Fig. 30: Start forward/Start reverse

1. The first selected direction has the highest priority.
2. When the DIN1 contact opens the direction of rotation starts the change.
3. If Start forward (DIN1) and Start reverse (DIN2) signals are active simultaneously the Start forward signal (DIN1) has priority.

A) Stop function (ID506) = coasting

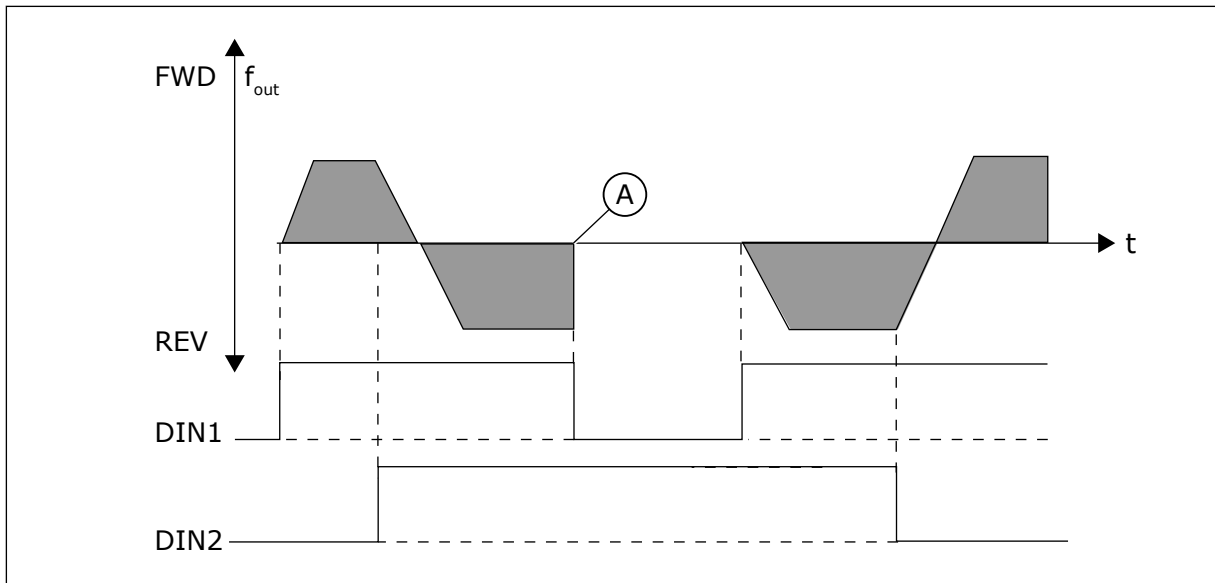

Fig. 31: Start, Stop, Reverse

A) Stop function (ID506) = coasting

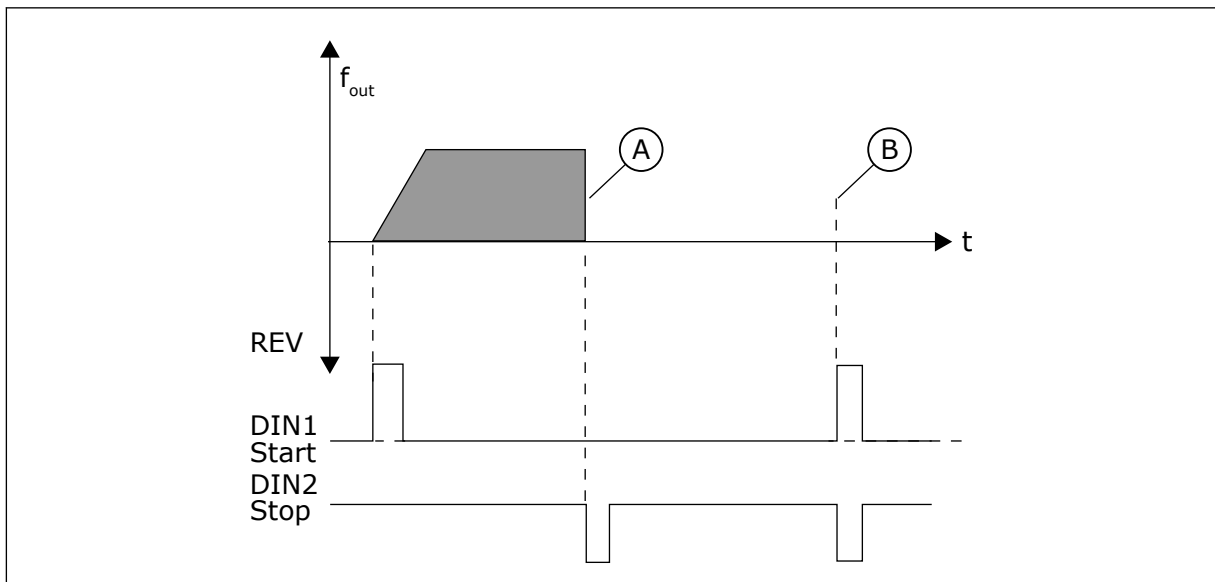

Fig. 32: Start pulse/ Stop pulse

A) Stop function (ID506) = coasting

B) If Start and Stop pulses are simultaneous the Stop pulse overrides the Start pulse

301 DIN3 FUNCTION 12345 (2.17, 2.2.2)

Use this parameter to select the function for the digital input A3.

Table 118: Selections for parameter ID301

Selection number	Selection name	Description	Notes
0	Not used		
1	External fault	Closing contact: Fault is shown and responded to according to ID701.	
2	External fault	Opening contact: Fault is shown and responded to according to ID701 when the input is not active.	
3	Run enable	Contact open: Motor start disabled and the motor is stopped READY signal is set to FALSE	
		Contact closed: Motor start enabled	
Application 1			
4	Run enable	Contact open: Motor start enabled	
		Contact closed: Motor start disabled and the motor is stopped	
Applications 2 to 5			
4	Acc./Dec time select.	Contact open: Acceleration/deceleration time 1 selected	When the control place is forced to change the values of Start/Stop, Direction and Reference valid in the respective control place are used (reference according to parameters ID117, ID121 and ID122).
		Contact closed: Acceleration/deceleration time 2 selected	
5	Closing contact	Force control place to I/O terminal	NOTE! The value of parameter ID125 Keypad Control Place does not change. When DIN3 opens the control place is selected according to parameter 3.1.
6	Closing contact	Force control place to keypad	
7	Closing contact	Force control place to fieldbus	
Applications 2 to 5			
8	Reverse	Contact open: Forward	Can be used for reversing if parameter ID300 value is set to either 2,3, or 6.
		Contact closed: Reverse	
Applications 3 to 5			
9	Jogging sp.	Contact closed: Jogging speed selected for frequency reference	

Table 118: Selections for parameter ID301

Selection number	Selection name	Description	Notes
10	Fault reset	Contact closed: Resets all faults	
11	Acc./dec. operation prohibited	Contact closed: Stops acceleration or deceleration until the contact is opened	
12	DC-braking command	Contact closed: In Stop mode, the DC-braking operates until the contact is opened, see Figure 30 as well as parameters ID507 and ID1080	
Applications 3 and 5			
13	Motor potentiometer down	Contact closed: Reference decreases until the contact is opened	
Application 4			
13	Preset speed		

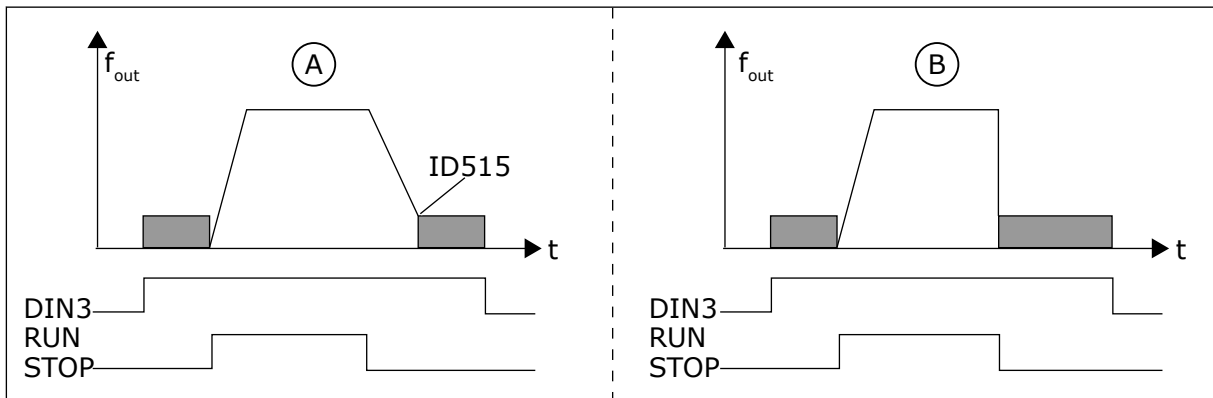

Fig. 33: DIN3 as DC-brake command input

A. Stop mode = Ramp

B. Stop mode = coasting

302 ANALOGUE INPUT 2, REFERENCE OFFSET 12 (2.15, 2.2.3)

Use this parameter to set the reference offset for analogue input.

Table 119: Selections for parameter ID302

Selection number	Selection name	Description
0	No offset: 0–20 mA	
1	Offset 4 mA (“living zero”)	Provides supervision of zero level signal. In Standard Application, the response to reference fault can be programmed with parameter ID700.

303 REFERENCE SCALING, MINIMUM VALUE 2346 (2.2.4, 2.2.16, 2.2.2.6)

Use this parameter to set additional reference scaling.

304 REFERENCE SCALING, MAXIMUM VALUE 2346 (2.2.5, 2.2.17, 2.2.2.7)

Use this parameter to set additional reference scaling.

If both parameter ID303 and parameter ID304 = 0 scaling is set off. The minimum and maximum frequencies are used for scaling.



NOTE!

This scaling does not affect the fieldbus reference (scaled between Minimum frequency (parameter ID101) and Maximum frequency (parameter ID102)).

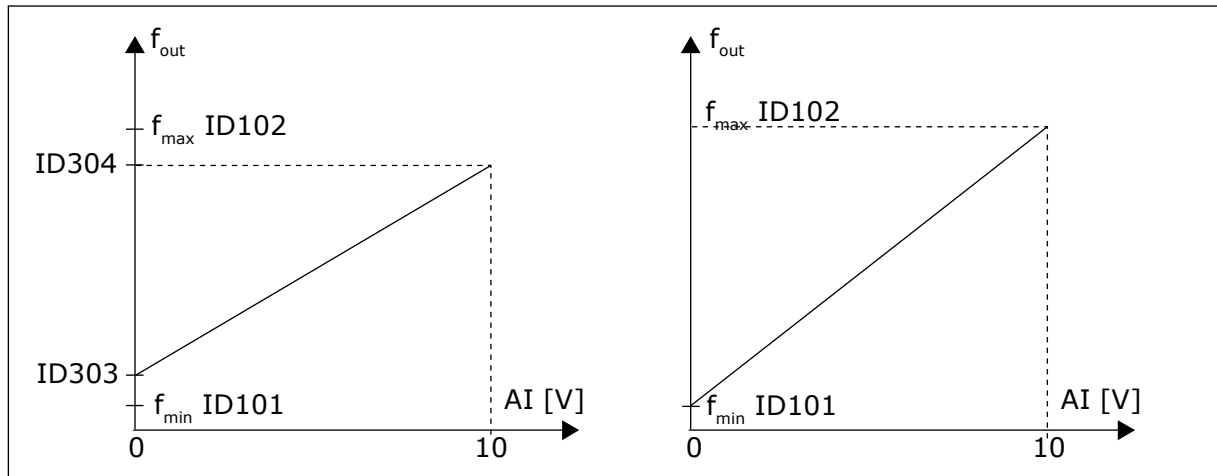

Fig. 34: Left: Reference scaling; Right: No scaling used (parameter ID303 = 0)

305 REFERENCE INVERSION 2 (2.2.6)

Use this parameter to invert the reference direction.

Inverts reference signal:
 Max. input signal = Min. freq. reference
 Min. input signal = Max. freq. reference

Table 120: Selections for parameter ID305

Selection number	Selection name	Description
0	No inversion	
1	Reference inverted	

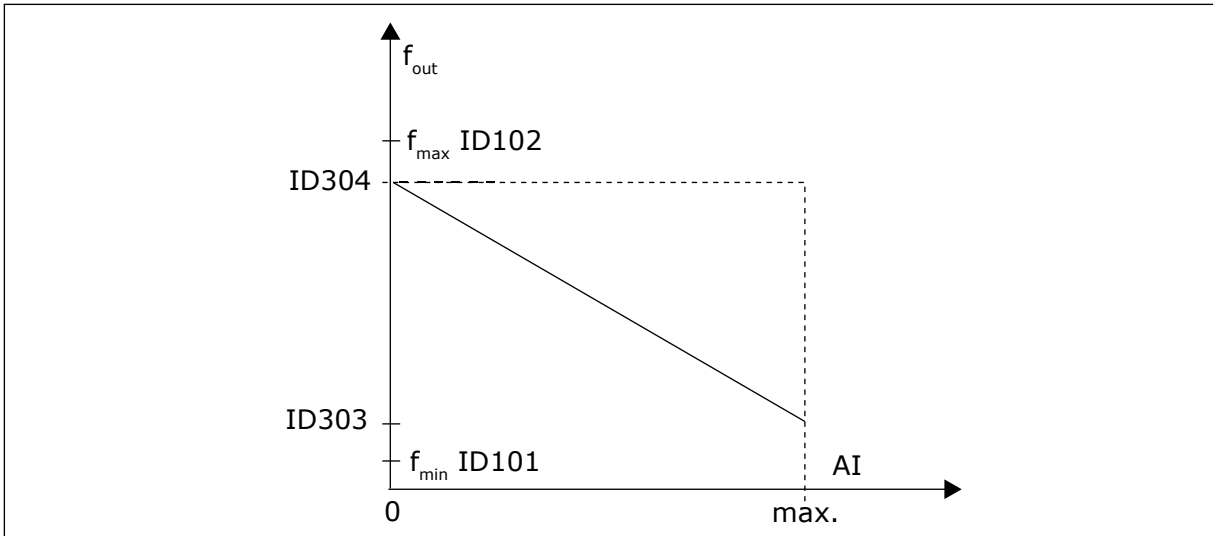

Fig. 35: Reference invert

306 REFERENCE FILTER TIME 2 (2.2.7)

Use this parameter to set the filtering time to filter disturbances from the analogue input signals AI1 and AI2.

Long filtering time makes regulation response slower.

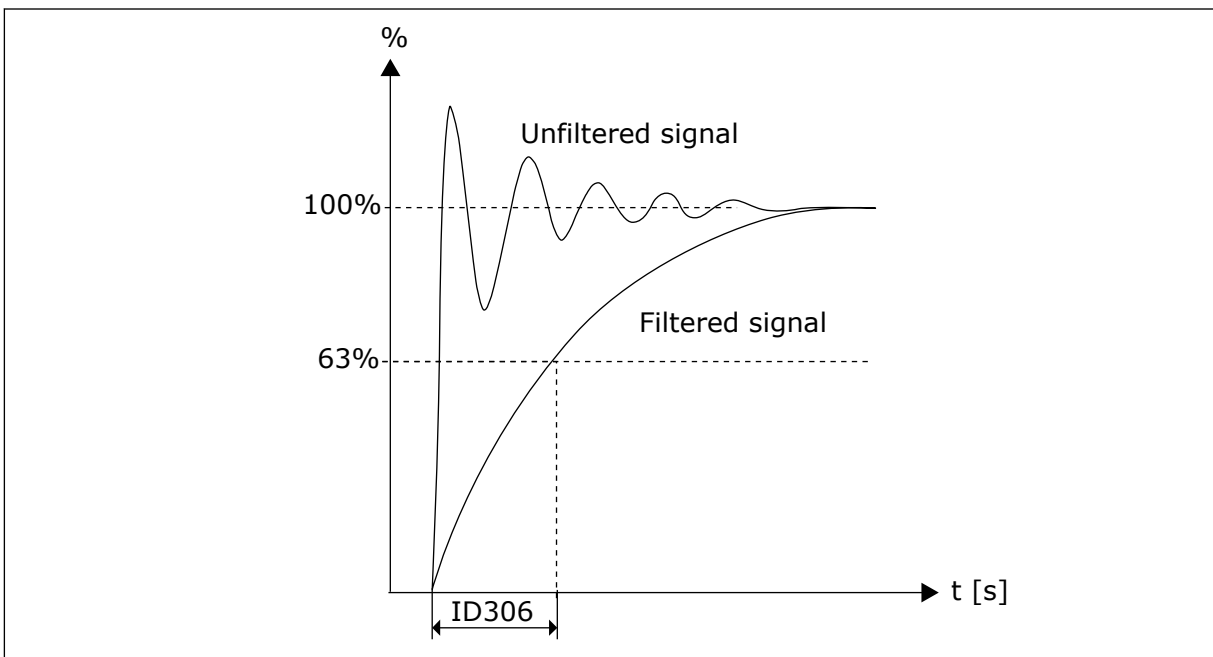

Fig. 36: Reference filtering

307 ANALOGUE OUTPUT FUNCTION (2.16, 2.3.2, 2.3.5.2, 2.3.3.2)

Use this parameter to select the function for the analogue output signal.

Table 121: Parameter ID307 selections

Applic.	1 to 4	5 and 7	6
Sel.			
0	Not used	Not used	Not used
1	Output freq. (0—fmax)	Output freq. (0—fmax)	Output freq. (0—fmax)
2	Freq. reference (0—fmax)	Freq. reference (0—fmax)	Freq. reference (0—fmax)
3	Motor speed (0—Motor nominal speed)	Motor speed (0—Motor nominal speed)	Motor speed (0—Motor nominal speed)
4	Output current (0—InMotor)	Output current (0—InMotor)	Output current (0—InMotor)
5	Motor torque (0—TnMotor)	Motor torque (0—TnMotor)	Motor torque (0—TnMotor)
6	Motor power (0—PnMotor)	Motor power (0—PnMotor)	Motor power (0—PnMotor)
7	Motor voltage (0—UnMotor)	Motor voltage (0—UnMotor)	Motor voltage (0—UnMotor)
8	DC-link volt (0—1000V)	DC-link volt (0—1000V)	DC-link volt (0—1000V)
9		PID controller ref. value	AI1
10		PID contr. act. value 1	AI2
11		PID contr. act. value 2	Output freq. (fmin - fmax)
12		PID contr. error value	Motor torque (-2...+2xTNmot)
13		PID controller output	Motor power (-2...+2xTNmot)
14		PT100 temperature	PT100 temperature
15			FB analogue output Process-Data4 (NXS)

308 ANALOGUE OUTPUT FILTER TIME 234567 (2.3.3, 2.3.5.3, 2.3.3.3)

Use this parameter to set the filtering time of the analogue output signal.

Setting this parameter value 0 will deactivate filtering.

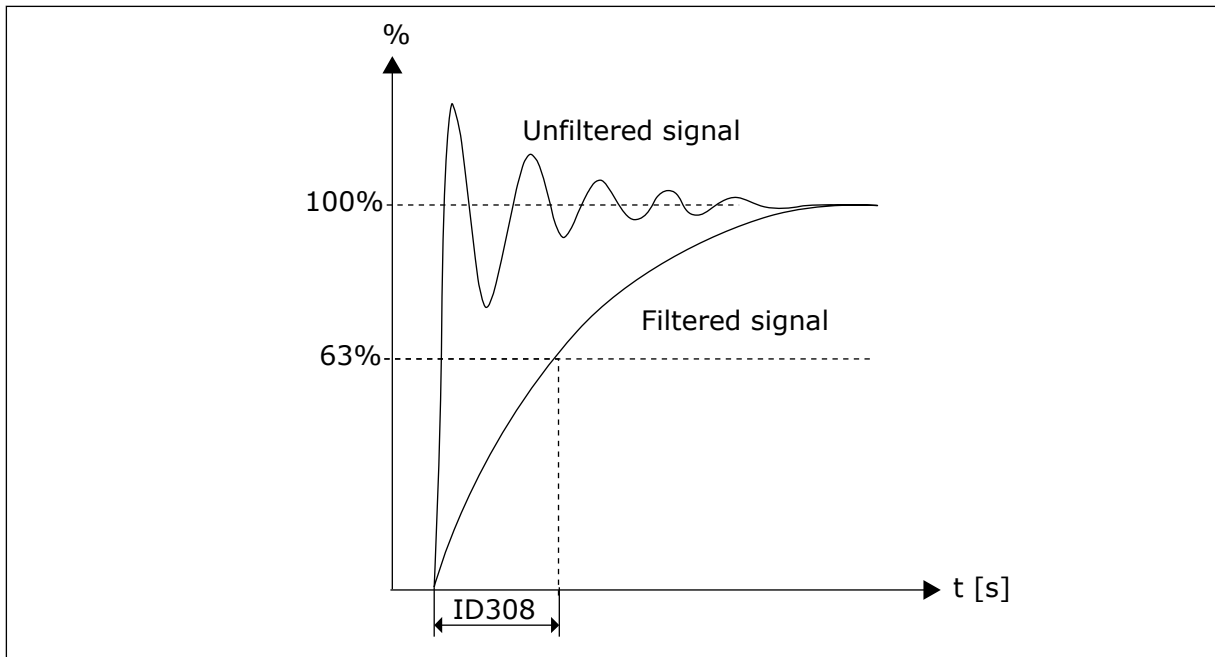

Fig. 37: Analogue output filtering

309 ANALOGUE OUTPUT INVERSION 234567 (2.3.4, 2.3.5.4, 2.3.3.4)

Use this parameter to invert the analogue output signal.

Maximum output signal = Minimum set value

Minimum output signal = Maximum set value

See parameter ID311 below.

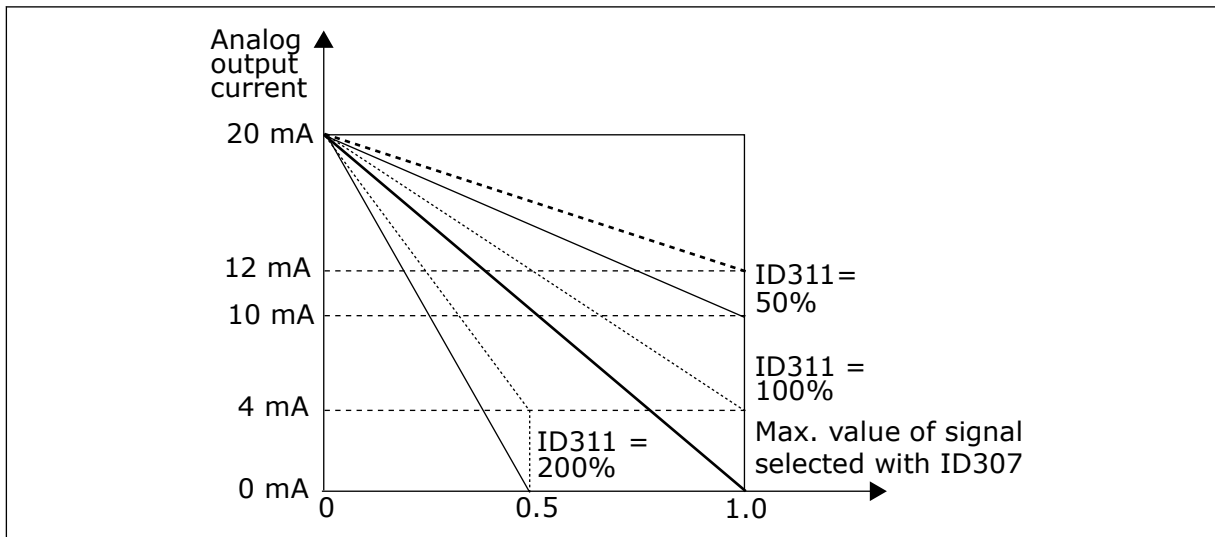

Fig. 38: Analogue output invert

310 ANALOGUE OUTPUT MINIMUM 234567 (2.3.5, 2.3.5.5, 2.3.3.5)

Use this parameter to set the minimum value of the analogue output signal.

Defines the signal minimum to either 0 mA or 4 mA (living zero). Note the difference in analogue output scaling in parameter ID311 (8-15).

Table 122: Selections for parameter ID310

Selection number	Selection name	Description
0	Set minimum value to 0 mA/0 V	
1	Set minimum value to 4 mA/2 V	

311 ANALOGUE OUTPUT SCALE 234567 (2.3.6, 2.3.5.6, 2.3.3.6)

Use this parameter to set the scaling factor for the analogue output.

Use the given formula to calculate the values.

Table 123: Analogue output scaling

Signal	Max. value of the signal
Output frequency	Max frequency (parameter ID102)
Freq. Reference	Max frequency (parameter ID102)
Motor speed	Motor nom. speed $1 \times n_{mMotor}$
Output current	Motor nom. current $1 \times I_{nMotor}$
Motor torque	Motor nom. torque $1 \times T_{nMotor}$
Motor power	Motor nom. power $1 \times P_{nMotor}$
Motor voltage	$100\% \times U_{nMotor}$
DC-link voltage	1000 V
PI-ref. value	$100\% \times \text{ref. value max.}$
PI act. value 1	$100\% \times \text{actual value max.}$
PI act. value 2	$100\% \times \text{actual value max.}$
PI error value	$100\% \times \text{error value max.}$
PI output	$100\% \times \text{output max.}$

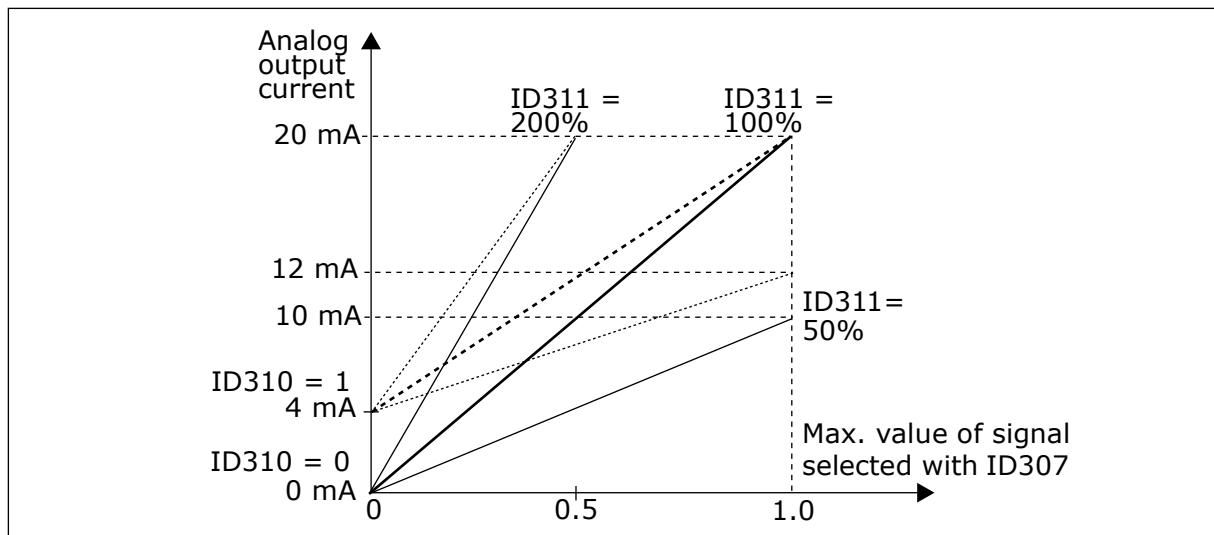

Fig. 39: Analogue output scaling

$$\text{OutputSignal} = \frac{\text{Signal} * \text{Analogue OutputScale}\%}{100\%}$$

312 DIGITAL OUTPUT FUNCTION 23456 (2.3.7, 2.3.1.2)

Use this parameter to select the function for the digital output signal.

313 RELAY OUTPUT 1 FUNCTION 2345 (2.3.8, 2.3.1.3)

Use this parameter to select the function for the relay output signal.

314 RELAY OUTPUT 2 FUNCTION 2345 (2.3.9)

Use this parameter to select the function for the relay output signal.

Table 124: Output signals via D01 and output relays R01 and R02

Setting value	Signal content
0 = Not used	Out of operation
	Digital output D01 sinks the current and programmable relay (R01, R02) is activated when:
1 = Ready	The AC drive is ready to operate
2 = Run	The AC drive operates (motor is running)
3 = Fault	A fault trip has occurred
4 = Fault inverted	A fault trip <u>not</u> occurred
5 = Frequency converter overheat warning	The heat-sink temperature exceeds +70 °C
6 = External fault or warning	Fault or warning depending on parameter ID701
7 = Reference fault or warning	Fault or warning depending on parameter ID700 - if analogue reference is 4–20 mA and signal is <4 mA
8 = Warning	Always if a warning exists
9 = Reversed	The reverse command has been selected
10 = Preset speed (Applications 2) 10 = Jogging speed (Applications 3456)	The preset speed has been selected with digital input The jogging speed has been selected with digital input
11 = At speed	The output frequency has reached the set reference.
12 = Motor regulator activated	One of the limit regulators (e.g. current limit, torque limit) is activated.
13 = Output frequency limit 1 supervision	The output frequency goes outside the set supervision low limit/high limit (see parameters ID315 and ID316 below).
14 = Control from I/O terminals (Appl. 2) 14 = Output frequency limit 2 supervision (Applications 3456)	I/O control mode selected (in menu M3) The output frequency goes outside the set supervision low limit/high limit (see parameters ID346 and ID347 below).
15 = Thermistor fault or warning (Appl.2) 15 = Torque limit supervision (Appl.3456)	The thermistor input of option board indicates motor overtemperature. Fault or warning depending on parameter ID732. The motor torque goes beyond the set supervision low limit/high limit (parameters ID348 and ID349).
16 = Fieldbus DIN1 (Application 2) 16 = Reference limit supervision	Fieldbus digital input 1. See fieldbus manual. Active reference goes beyond the set supervision low limit/high limit (parameters ID350 and ID351).

Table 124: Output signals via DO1 and output relays RO1 and RO2

Setting value	Signal content
17 = External brake control (Appl. 3456)	External brake ON/OFF control with programmable delay (parameters ID352 and ID353)
18 = Control from I/O terminals (Appl. 3456)	External control mode (Menu M3; ID125)
19 = Frequency converter temperature limit supervision (Appl. 3456)	The AC drive heatsink temperature goes beyond the set supervision limits (parameters ID354 and ID355).
20 = Unrequested rotation direction (Appl. 345) 20 = Reference inverted (Appl. 6)	Rotation direction is different from the requested one.
21 = External brake control inverted (Appl. 3456)	External brake ON/OFF control (parameters ID352 and ID353); Output active when brake control is OFF
22 = Thermistor fault or warning (Appl. 3456)	The thermistor input of option board indicates motor overtemperature. Fault or warning depending on parameter ID732.
23 = Fieldbus DIN1 (Application 5) 23 = Analogue input supervision (Application 6)	Fieldbus digital input 1. See fieldbus manual. Selects the analogue input to be monitored. See parameters ID356, ID357, ID358 and ID463.
24 = Fieldbus DIN1 (Application 6)	Fieldbus digital input 1. See fieldbus manual.
25 = Fieldbus DIN2 (Application 6)	Fieldbus digital input 2. See fieldbus manual.
26 = Fieldbus DIN3 (Application 6)	Fieldbus digital input 3. See fieldbus manual.

315 OUTPUT FREQUENCY LIMIT SUPERVISION FUNCTION 234567 (2.3.10, 2.3.4.1, 2.3.2.1)

Use this parameter to select the limit supervision function for the output frequency.

Table 125: Selections for parameter ID315

Selection number	Selection name	Description
0	No supervision	
1	Low limit supervision	
2	High limit supervision	
3	Brake-on control	(Application 6 only, see Chapter 9.3 External brake control with additional limits (IDs 315, 316, 346 to 349, 352, 353).)

If the output frequency goes under/over the set limit (ID316) this function generates a message via digital output depending

1. on the settings of parameters ID312 to ID314 (applications 3,4,5) or
2. on to which output the supervision signal 1 (ID447) is connected (applications 6 and 7).

Brake control uses different output functions. See ID445 & ID446.

316 OUTPUT FREQUENCY LIMIT SUPERVISION VALUE 234567 (2.3.11, 2.3.4.2, 2.3.2.2)

Use this parameter to set the limit supervision value for the output frequency when you activate the limit supervision function.

Selects the frequency value supervised by parameter ID315.

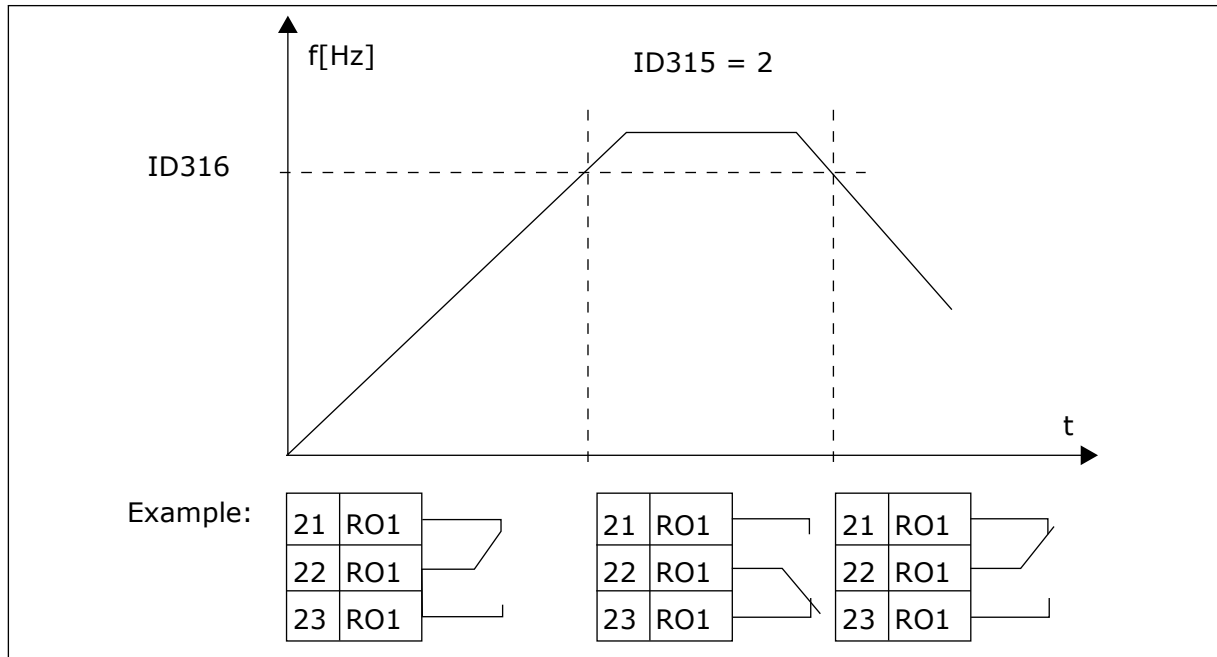

Fig. 40: Output frequency supervision

319 DIN2 FUNCTION 5 (2.2.1)

Use this parameter to select the function for the digital input signal.

This parameter has 14 selections. If digital input DIN2 need not be used, set the parameter value to 0.

Table 126: Selections for parameter ID319

Selection number	Selection name	Description	Notes
1	External fault, normally open	Contact closed: Fault is displayed and motor stopped when the input is active	
2	External fault, normally closed	Contact open: Fault is displayed and motor stopped when the input is not active.	
3	Run enable	Contact open, Start of motor disabled.	
		Contact closed: Start of motor enabled	
4	Acceleration or deceleration time selection	Contact open, Acceleration/Deceleration time 1 selected	
		Contact closed: Acceleration/Deceleration time 2 selected	
5	Closing contact	Force control place to I/O terminal	When the control place is forced to change the values of Start/Stop, Direction and Reference valid in the respective control place are used (reference according to parameters ID343, ID121 and ID122). NOTE! The value of ID125 (Keypad Control Place) does not change. When DIN2 opens the control place is selected according to keypad control place selection.
6	Closing contact	Force control place to keypad	
7	Closing contact	Force control place to fieldbus	
8	Reverse	Contact open:Forward	If several inputs are programmed to reverse, one active contact is enough to set the direction to reverse.
		Contact closed:Reverse	
9	Jogging speed (see par. ID124)	Contact closed: Jogging speed selected for frequency reference	
10	Fault reset	Contact closed: Resets all faults	
11	Acceleration/Deceleration prohibited	Contact closed: No acceleration or deceleration possible until the contact is opened	
12	DC-braking command	Contact closed: In Stop mode, the DC braking operates until the contact is opened. See Fig. 41 DC braking command (selection 12) selected for DIN2	

Table 126: Selections for parameter ID319

Selection number	Selection name	Description	Notes
13	Motor potentiometer UP	Contact closed: Reference increases until the contact is opened.	

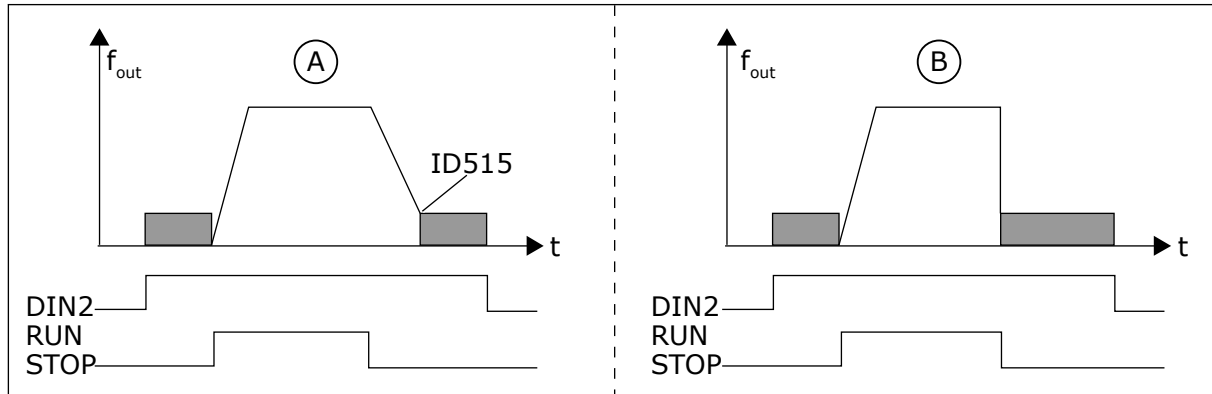

Fig. 41: DC braking command (selection 12) selected for DIN2

A. Stop mode = Ramp

B. Stop mode = Coasting

320 AI1 SIGNAL RANGE 34567 (2.2.4, 2.2.16, 2.2.2.3)

Use this parameter to select the range for the analogue input signal.

Table 127: Selections for parameter ID320

Applic.	3, 4, 5	6	7
Sel.			
0	0-100%	0-100%	0-100%
1	4 mA/20-100%	4 mA/20-100%	4 mA/20-100%
2	Customised	-10...+10 V	Customised
3		Customised	

For selection 'Customised', see parameters ID321 and ID322.

321 AI1 CUSTOM SETTING MINIMUM 34567 (2.2.5, 2.2.17, 2.2.2.4)

Use this parameter to adjust the minimum value of the analogue input signal between -160%...160% freely.

322 AI1 CUSTOM SETTING MAXIMUM 34567 (2.2.6, 2.2.18, 2.2.2.5)

Use this parameter to adjust the maximum value of the analogue input signal between -160%...160% freely.

For example, you can use the analogue input signal as frequency reference, and set these 2 parameters between 40 and 80%. In these conditions, the frequency reference changes between the Minimum frequency reference (ID101) and the Maximum frequency reference (ID102), and the analogue input signal changes between 8 and 16 mA.

323 AI1 SIGNAL INVERSION 3457 (2.2.7, 2.2.19, 2.2.2.6)

Use this parameter to invert the analogue input signal.

If this parameter = 0, no inversion of analogue input signal takes place



NOTE!

In application 3, AI1 is place B frequency reference if parameter ID131= 0 (default).

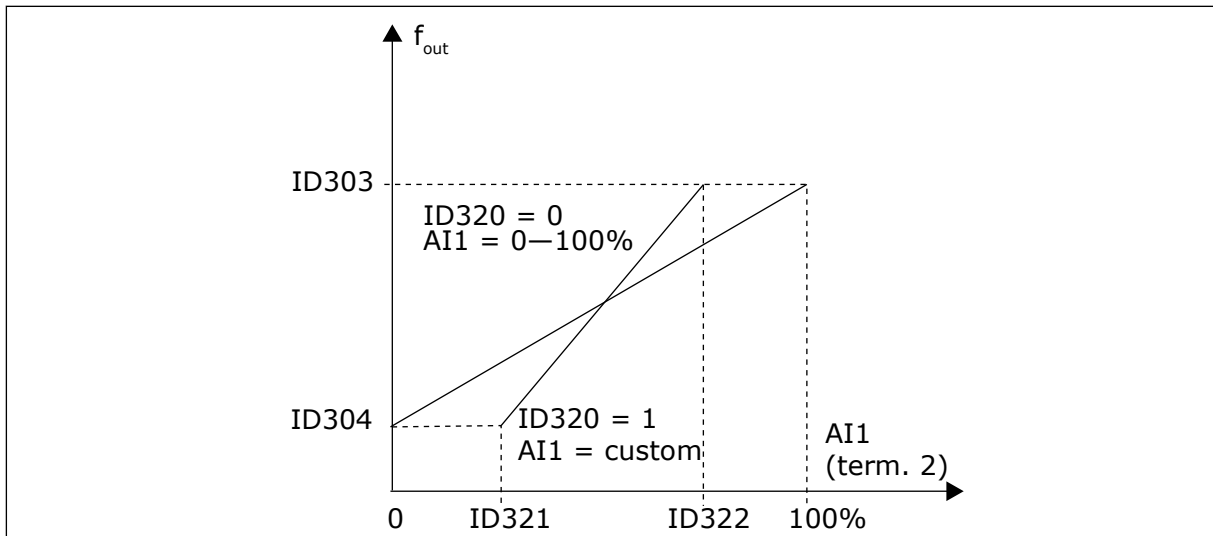

Fig. 42: AI1 no signal inversion

If this parameter = 1 inversion of analogue input signal takes place.

Max. AI1 signal = minimum frequency ref.

Min. AI1 signal = maximum frequency ref.

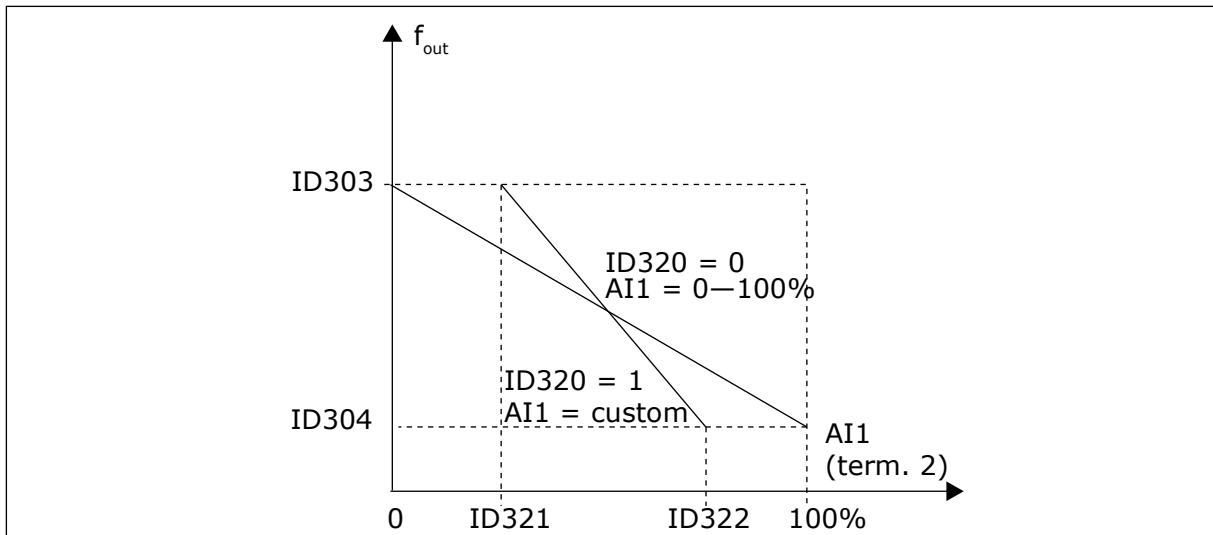

Fig. 43: AI1 signal inversion

324 AI1 SIGNAL FILTER TIME 34567 (2.2.8, 2.2.20, 2.2.2.2)

Use this parameter to filter out disturbances in the analogue input signal.

To activate this parameter, give it a value that is bigger than 0.



NOTE!

Long filtering time makes the regulation response slower.

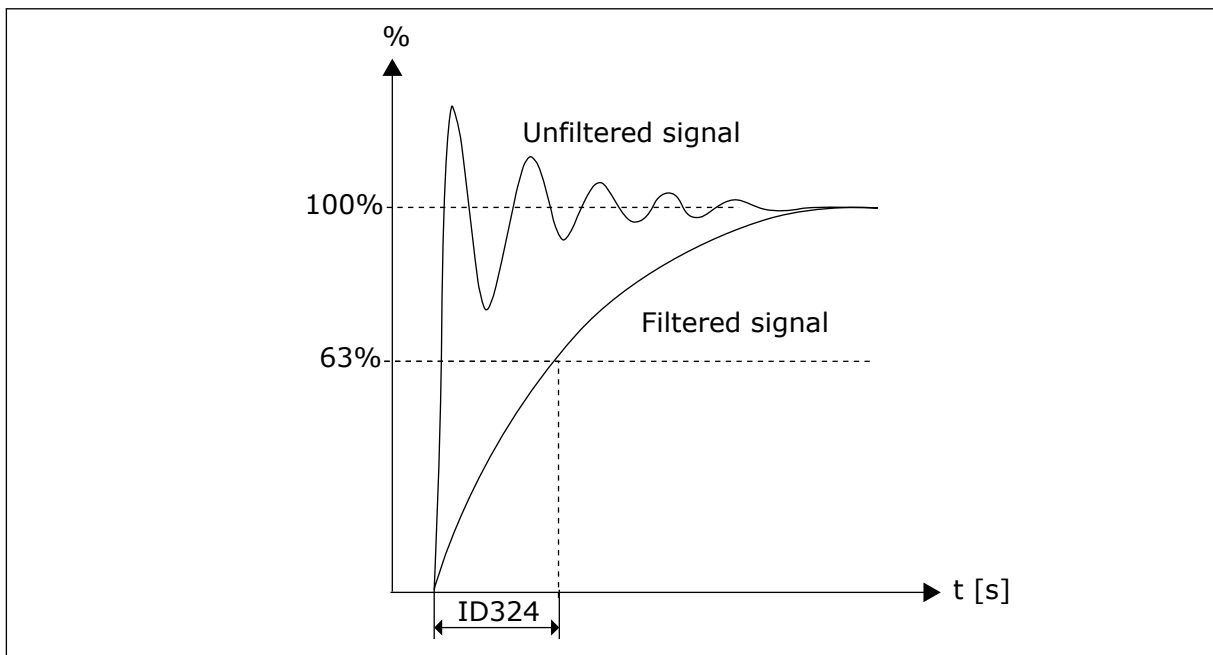

Fig. 44: AI1 signal filtering

325 ANALOGUE INPUT AI2 SIGNAL RANGE 34567 (2.2.10, 2.2.22, 2.2.3.3)

Use this parameter to select the range for the analogue input signal.

Table 128: Selections for parameter ID325

Applic.	3, 4	5	6	7
Sel.				
0	0-20 mA	0-20 mA	0-100%	0-100%
1	4-20 mA	4 mA/20-100%	4 mA/20-100%	4 mA/20-100%
2	Customised	Customised	-10...+10 V	Customised
3			Customised	

326 ANALOGUE INPUT AI2 CUSTOM SETTING MIN. 34567 (2.2.11, 2.2.23, 2.2.3.4)

Use this parameter to adjust the minimum value of the analogue input signal between -160%...160% freely.

327 ANALOGUE INPUT AI2 CUSTOM SETTING MAX. 34567 (2.2.12, 2.2.24, 2.2.3.5)

Use this parameter to adjust the maximum value of the analogue input signal between -160%...160% freely.

See ID322.

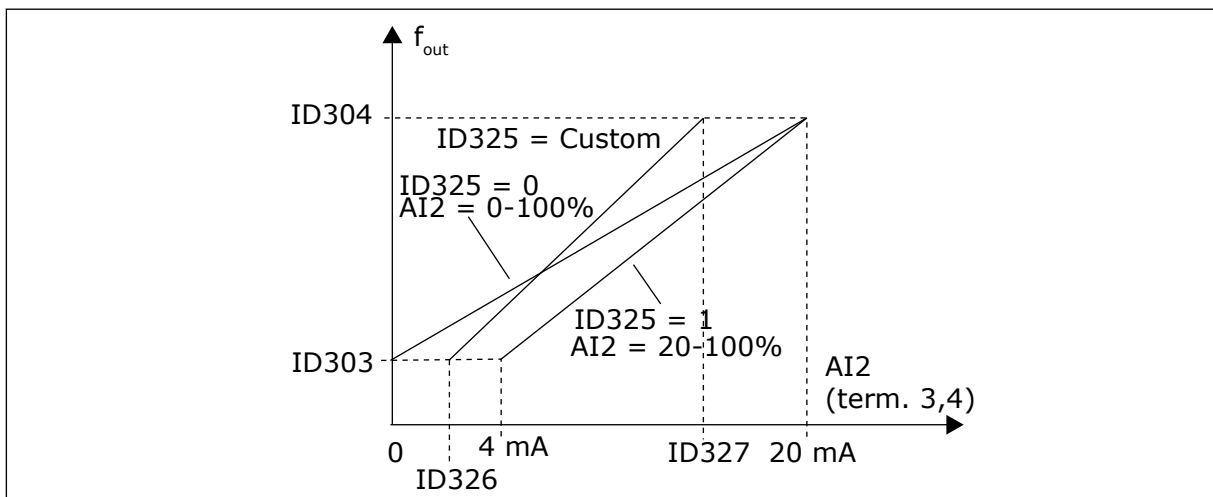

Fig. 45: Analogue input AI2 scaling

328 ANALOGUE INPUT 2 INVERSION 3457 (2.2.13, 2.2.25, 2.2.3.6)

Use this parameter to invert the analogue input signal.

See ID323.



NOTE!

In application 3, AI2 is the place A frequency reference, if parameter ID117 = 1 (default)

329 ANALOGUE INPUT 2 FILTER TIME 34567 (2.2.14, 2.2.26, 2.2.3.2)

Use this parameter to filter out disturbances in the analogue input signal.

See ID324.

330 DIN5 FUNCTION 5 (2.2.3)

Use this parameter to select the function for the digital input signal.

The digital input DIN5 has 14 possible functions. If it need not be used, set the value of this parameter to 0.

The selections are the same as in parameter ID319 except:

13 Enable PID reference 2

Contact open: PID controller reference selected with parameter ID332.

Contact closed: PID controller keypad reference 2 selected with parameter R3.5.

331 MOTOR POTENTIOMETER RAMP TIME 3567 (2.2.22, 2.2.27, 2.2.1.2, 2.2.1.15)

Use this parameter to set the rate of change in the motor potentiometer reference when it is increased or decreased.

Motor control ramp times are still active.

332 PID CONTROLLER REFERENCE SIGNAL (PLACE A) 57 (2.1.11)

Use this parameter to select the source of the PID controller signal.

Table 129: Selection for parameter ID332

Applic.	5	7
Sel.		
0	Analogue input 1	Analogue input 1
1	Analogue input 2	Analogue input 2
2	PID ref. from menu M3, parameter P3.4	AI3
3	Fieldbus ref. (FBProcessDataIN1) See Chapter 9.7 <i>Fieldbus control parameters (IDs 850 to 859)</i> .	AI4
4	Motor potentiometer reference	PID ref. from menu M3, parameter P3.4
5		Fieldbus ref. (FBProcessDataIN1) See Chapter 9.7 <i>Fieldbus control parameters (IDs 850 to 859)</i> .
6		Motor potentiometer reference

333 PID CONTROLLER ACTUAL VALUE SELECTION 57 (2.2.8, 2.2.1.8)

Use this parameter to select the actual value of the PID controller signal.

Table 130: Selections for parameter ID333

Selection number	Selection name	Description
0	Actual value 1	
1	Actual value 1 + Actual value 2	
2	Actual value 1 – Actual value 2	
3	Actual value 1 * Actual value 2	
4	Smaller one of Actual value 1 and Actual value 2	
5	Greater one of Actual value 1 and Actual value 2	
6	Mean value of Actual value 1 and Actual value 2	
7	Square root of Actual value 1 + Square root of Actual value 2	

334 ACTUAL VALUE 1 SELECTION 57 (2.2.9, 2.2.1.9)

Use this parameter to select the source of the actual value.

335 ACTUAL VALUE 2 SELECTION 57 (2.2.10, 2.2.1.10)

Use this parameter to select the source of the actual value.

Table 131: Selections for parameter IDs 334 and 335

Selection number	Selection name	Description
0	Not used	
1	AI1	
2	AI2	
3	AI3	
4	AI4	
5	Fieldbus	[Actualvalue 1: FBProcessDataIN2; Actual value 2: FBProcessDataIN3]. See Chapter 9.7 <i>Fieldbus control parameters (IDs 850 to 859)</i> .
Application 5		
6	Motor torque	
7	Motor speed	
8	Motor current	
9	Motor power	
10	Encoder frequency (for Actual value 1 only)	

336 ACTUAL VALUE 1 MINIMUM SCALE 57 (2.2.11, 2.2.1.11)

Use this parameter to set the minimum scaling point of the actual value.

See Fig. 46 *Examples of actual value signal scaling*.

337 ACTUAL VALUE 1 MAXIMUM SCALE 57 (2.2.12, 2.2.1.12)

Use this parameter to set the maximum scaling point of the actual value.

See Fig. 46 *Examples of actual value signal scaling*.

338 ACTUAL VALUE 2 MINIMUM SCALE 57 (2.2.13, 2.2.1.13)

Use this parameter to set the minimum scaling point of the actual value.

Sets the minimum scaling point for Actual value 2. See Chapter 339 *Actual value 2 maximum scale 57 (2.2.14, 2.2.1.14)*.

339 ACTUAL VALUE 2 MAXIMUM SCALE 57 (2.2.14, 2.2.1.14)

Use this parameter to set the maximum scaling point of the actual value.

Sets the maximum scaling point for Actual value 2. See Fig. 46 *Examples of actual value signal scaling*.

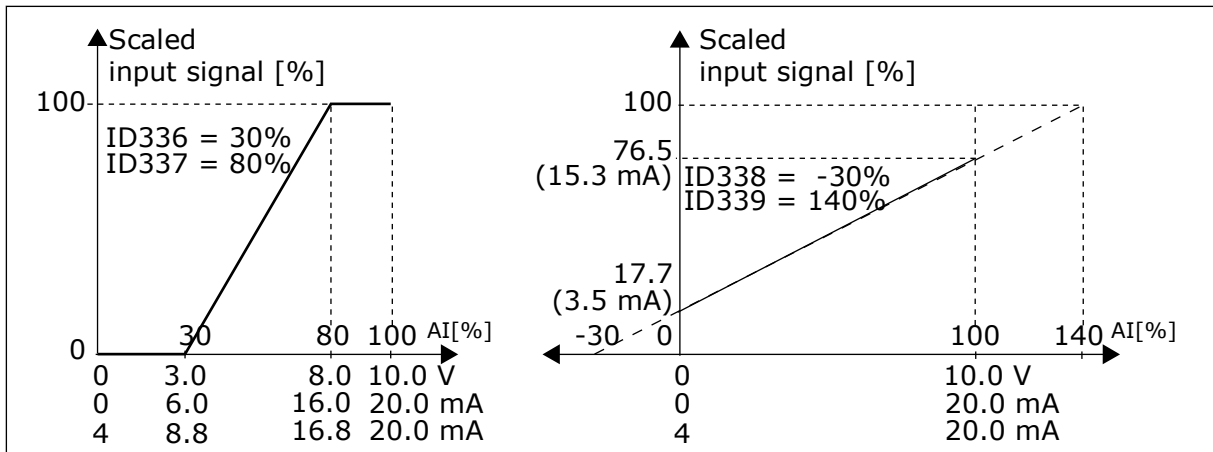

Fig. 46: Examples of actual value signal scaling

340 PID ERROR VALUE INVERSION 57 (2.2.32, 2.2.1.5)

Use this parameter to invert the error value of the PID controller.

Table 132: Selections for parameter ID340

Selection number	Selection name	Description
0	No inversion	
1	Inverted	

341 PID REFERENCE RISE TIME 57 (2.2.33, 2.2.1.6)

Use this parameter to set the time during which the PID controller reference rises from 0% to 100%.

342 PID REFERENCE FALL TIME 57 (2.2.34, 2.2.1.7)

Use this parameter to set the time during which the PID controller reference falls from 100% to 0%.

343 I/O REFERENCE SELECTION 57 (2.2.34, 2.2.1.7)

Use this parameter to select the frequency reference source when I/O terminal is the control place and the reference source B is active.

Table 133: Selections for parameter ID343

Selection number	Selection name	Description
0	AI1 reference	(terminals 2 and 3, e.g. potentiometer)
1	AI2 reference	(terminals 5 and 6, e.g. transducer)
2	AI3 reference	
3	AI4 reference	
4	Keypad reference (parameter R3.2)	
5	Reference from Fieldbus (FBSpeedReference)	
6	Motor potentiometer reference	
7	PID controller reference	

Select actual value (parameter ID333 to ID339) and the PID control reference (parameter ID332). If value 6 is selected for this parameter in Application 5, the values of parameters ID319 and ID301 are automatically set to 13.

In Application 7, the functions Motorpotentiometer DOWN and Motorpotentiometer UP must be connected to digital inputs (parameters ID417 and ID418), if value 6 is selected for this parameter.

344 REFERENCE SCALING MINIMUM VALUE, PLACE B 57 (2.2.35, 2.2.1.18)

Use this parameter to set the minimum scaling point of the reference value.

345 REFERENCE SCALING MAXIMUM VALUE, PLACE B 57 (2.2.36, 2.2.1.19)

Use this parameter to set the maximum scaling point of the reference value.

You can choose a scaling range for the frequency reference from control place B between the Minimum and Maximum frequency.

If no scaling is desired set the parameter value to 0.

In figures below, input AI1 with signal range 0-100% is selected for Place B reference.



NOTE!

This scaling does not affect the fieldbus reference (scaled between Minimum frequency (parameter ID101) and Maximum frequency (parameter ID102)).

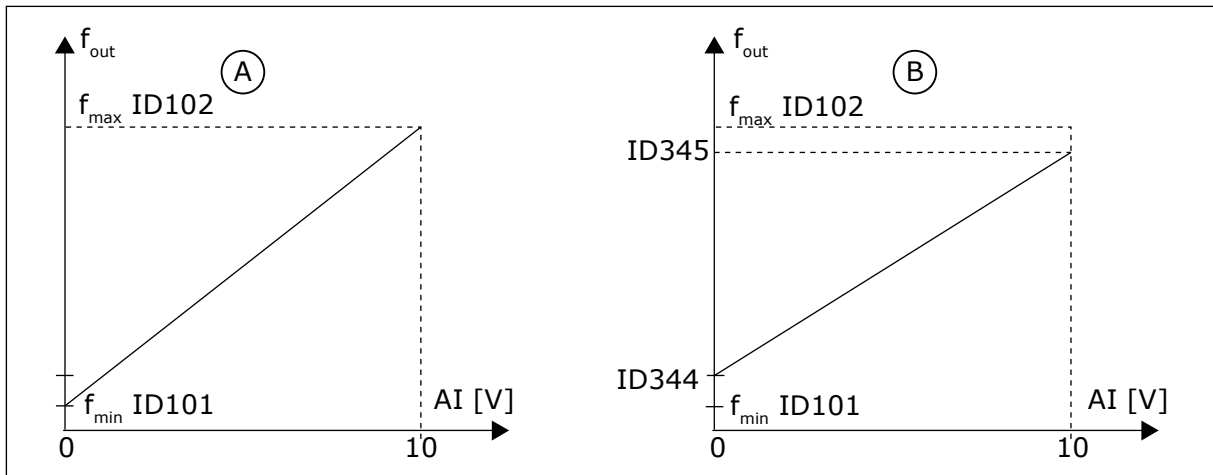

Fig. 47: Reference scaling maximum value

A. Par. ID344=0 (No reference scaling) B. Reference scaling

346 OUTPUT FREQ. LIMIT 2 SUPERVISION FUNCTION 34567 (2.3.12, 2.3.4.3, 2.3.2.3)

Use this parameter to select the limit supervision function for the output frequency.

Table 134: Selections for parameter ID346

Selection number	Selection name	Description
0	No supervision	
1	Low limit supervision	
2	High limit supervision	
3	Brake-on control	(Application 6 only, see Chapter 9.3 External brake control with additional limits (IDs 315, 316, 346 to 349, 352, 353).)
4	Brake-on/off control	(Application 6 only, see Chapter 9.3 External brake control with additional limits (IDs 315, 316, 346 to 349, 352, 353).)

If the output frequency goes under/over the set limit (ID347) this function generates a warning message through a digital output depending on

1. the settings of parameters ID312 to ID314 (applications 3,4,5) or
2. to which output the supervision signal 2 (ID448) is connected (applications 6 and 7).

Brake control uses different output functions. See parameters ID445 & ID446.

347 OUTPUT FREQUENCY LIMIT 2 SUPERVISION VALUE 34567 (2.3.13, 2.3.4.4, 2.3.2.4)

Use this parameter to set the limit supervision value for the output frequency when you activate the limit supervision function.

Selects the frequency value supervised by parameter ID346. See Fig. 40 Output frequency supervision.

348 TORQUE LIMIT, SUPERVISION FUNCTION 34567 (2.3.14, 2.3.4.5, 2.3.2.5)

Use this parameter to select the limit supervision function for the calculated torque value.

Table 135: Selections for parameter ID348

Selection number	Selection name	Description
0	No supervision	
1	Low limit supervision	
2	High limit supervision	
3	Brake-off control	(Application 6 only, see Chapter 9.3 External brake control with additional limits (IDs 315, 316, 346 to 349, 352, 353).)

If the calculated torque value falls below or exceeds the set limit (ID349) this function generates a message through a digital output depending on

1. the settings of parameters ID312 to ID314 (applications 3,4,5) or
2. to which output the torque limit supervision signal (parameter ID451) is connected (applications 6 and 7).

349 TORQUE LIMIT, SUPERVISION VALUE 34567 (2.3.15, 2.3.4.6, 2.3.2.6)

Use this parameter to set the limit supervision value for the torque when you activate the torque limit supervision function.

Set here the torque value to be supervised by parameter ID348.

APPLICATIONS 3 AND 4:

Torque supervision value can be reduced below the setpoint with external free analogue input signal selection and selected function, see parameters ID361 and ID362.

350 REFERENCE LIMIT, SUPERVISION FUNCTION 34567 (2.3.16, 2.3.4.7, 2.3.2.7)

Use this parameter to select the limit supervision function for the reference value.

Table 136: Selections for parameter ID350

Selection number	Selection name	Description
0	No supervision	
1	Low limit supervision	
2	High limit supervision	

If the reference value falls below or exceeds the set limit (ID351), this function generates a warning through a digital output depending on

1. the settings of parameters ID312 to ID314 (applications 3,4,5) or
2. to which output the reference limit supervision signal (parameter ID449) is connected (applications 6 and 7).

The supervised reference is the current active reference. It can be place A or B reference depending on DIN6 input, I/O reference, panel reference or fieldbus reference.

351 REFERENCE LIMIT, SUPERVISION VALUE 34567 (2.3.17, 2.3.4.8, 2.3.2.8)

Use this parameter to set the limit supervision value for the reference value when you activate the reference limit supervision function.

The frequency value to be supervised with the parameter ID350. Give the value in percent of the scale between the minimum and maximum frequencies.

352 EXTERNAL BRAKE-OFF DELAY 34567 (2.3.18, 2.3.4.9, 2.3.2.9)

Use this parameter to set the delay time to open the brake after the conditions to open the brake are filled.

353 EXTERNAL BRAKE-ON DELAY 34567 (2.3.19, 2.3.4.10, 2.3.2.10)

Use this parameter to set the delay time to close the brake after the conditions to close the brake are filled.

The function of the external brake can be timed to the start and stop control signals with these parameters. See Fig. 48 External brake control and Chapter 9.3 External brake control with additional limits (IDs 315, 316, 346 to 349, 352, 353).

The brake control signal can be programmed via the digital output DO1 or via one of the relay outputs RO1 and RO2, see parameters ID312 to ID314 (applications 3,4,5) or ID445 (applications 6 and 7). The brake-on delay is ignored when the unit is reaching a stop state after a rampdown or if stopped by coasting.

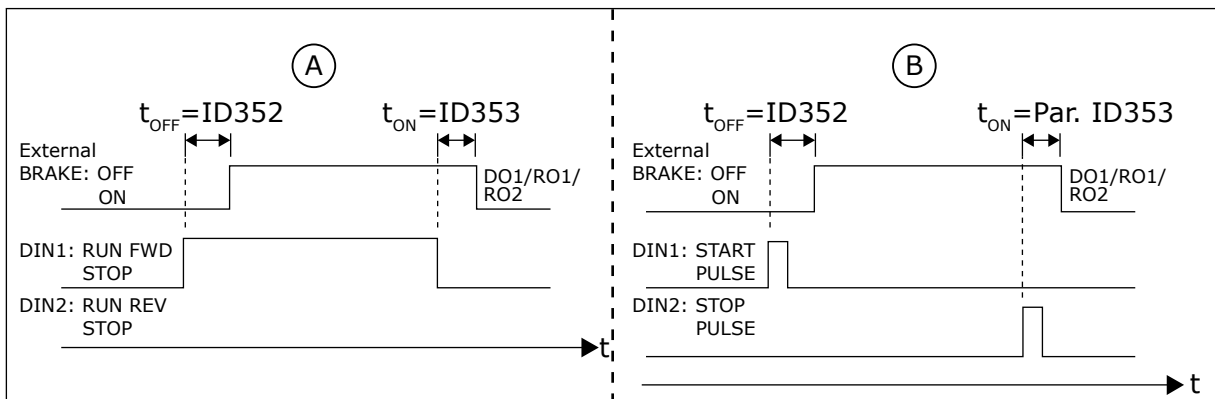

Fig. 48: External brake control

- A. Start/Stop logic selection, ID300 = 0, 1 or 2 B. Start/Stop logic selection, ID300= 3

354 FREQUENCY CONVERTER TEMPERATURE LIMIT SUPERVISION 34567 (2.3.20, 2.3.4.11, 2.3.2.11)

Use this parameter to select the limit supervision function for the temperature of the AC drive.

Table 137: Selections for parameter ID354

Selection number	Selection name	Description
0	No supervision	
1	Low limit supervision	
2	High limit supervision	

If the temperature of the AC drive unit falls below or exceeds the set limit (ID355), this function generates a message through a digital output depending on

1. the settings of parameters ID312 to ID314 (applications 3,4,5) or
2. to which output the temperature limit supervision signal (parameter ID450) is connected (applications 6 and 7).

355 FREQUENCY CONVERTER TEMPERATURE LIMIT VALUE 34567 (2.3.21, 2.3.4.12, 2.3.2.12)

Use this parameter to set the limit supervision value for the temperature when you activate the temperature limit supervision function.

This temperature value is supervised by parameter ID354.

356 ANALOGUE SUPERVISION SIGNAL 6 (2.3.4.13)

Use this parameter to select the analogue input you want to monitor.

Table 138: Selections for parameter ID356

Selection number	Selection name	Description
0	Not used	
1	AI1	
2	AI2	
3	AI3	
4	AI4	

357 ANALOGUE SUPERVISION LOW LIMIT 6 (2.3.4.14)

Use this parameter to set the low limit for the analogue input you selected to be monitored.

358 ANALOGUE SUPERVISION HIGH LIMIT 6 (2.3.4.15)

Use this parameter to set the high limit for the analogue input you selected to be monitored. These parameters set the low and high limits of the signal selected with parameter ID356.

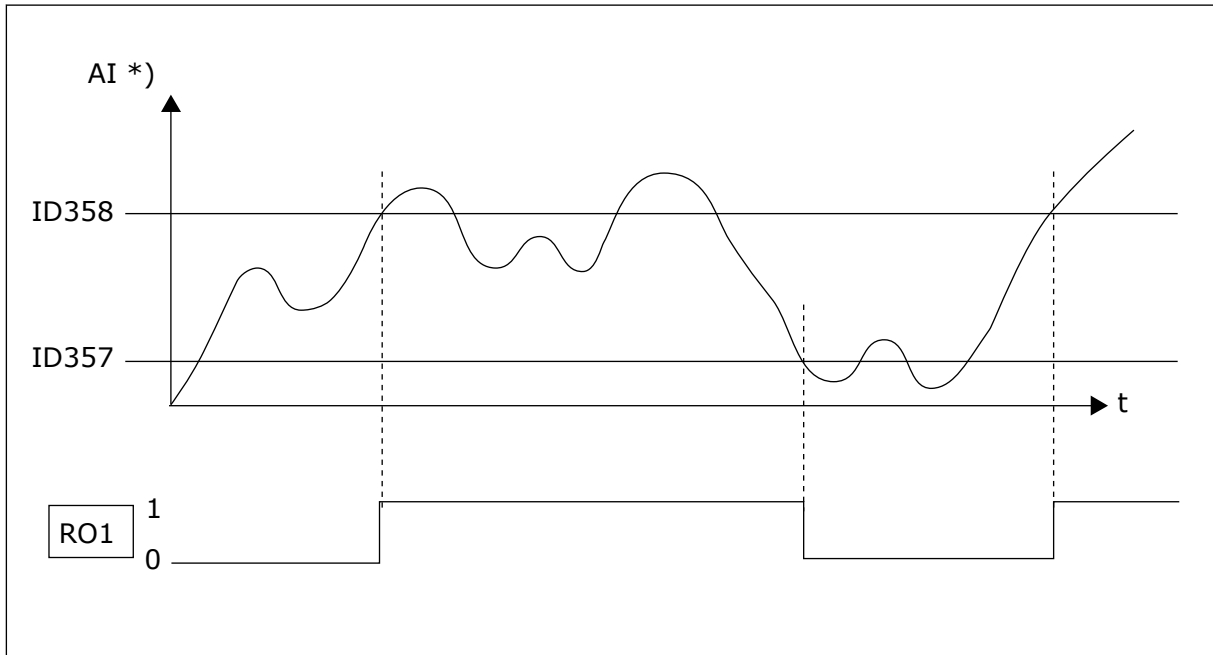

Fig. 49: An example of On/Off-control

*) Selected with par. ID356

**NOTE!**

In this example the programming of par. ID463 = B.1

359 PID CONTROLLER MINIMUM LIMIT 5 (2.2.30)

Use this parameter to set the minimum limit for the PID controller output.

360 PID CONTROLLER MAXIMUM LIMIT 5 (2.2.31)

Use this parameter to set the maximum limit for the PID controller output.

Limit setting: -1600.0% (of f_{max}) < par. ID359 < par. ID360 < 1600.0% (of f_{max}).

These limits are of importance for example when you define the gain, I-time and Dtime for the PID controller.

361 FREE ANALOGUE INPUT, SIGNAL SELECTION 34 (2.2.20, 2.2.17)

Use this parameter to select the input signal for an analogue input that is not in use for reference signal.

Table 139: Selections for parameter ID361

Selection number	Selection name	Description
0	Not in use	
1	Analogue input 1 (AI1)	
2	Analogue input 2 (AI2)	

362 FREE ANALOGUE INPUT, FUNCTION 34 (2.2.21, 2.2.18)

Use this parameter to select the function for an analogue input that is not in use for reference signal.

Table 140: Selections for parameter ID362

Selection number	Selection name	Description
0	Function is not in use	
1	Reduces motor current limit (ID107)	This signal will adjust the maximum motor current between 0 and max. limit set with ID107. See Fig. 50.
2	Reduces DC braking current	DC braking current can be reduced with the free analogue input signal between zero current and the current set with the parameter ID507. See Fig. 51.
3	Reduces acceleration and deceleration times	Acceleration and deceleration times can be reduced with the free analogue input signal according to the following formulas: Reduced time = set acc./deceler. time (parameters ID103, ID104; ID502, ID503) divided by the factor R in Fig. 52.
4	Reduces torque supervision limit	Set supervision limit can be reduced with the free analogue input signal between 0 and set torque limit supervision value (ID349), see Fig. 53.

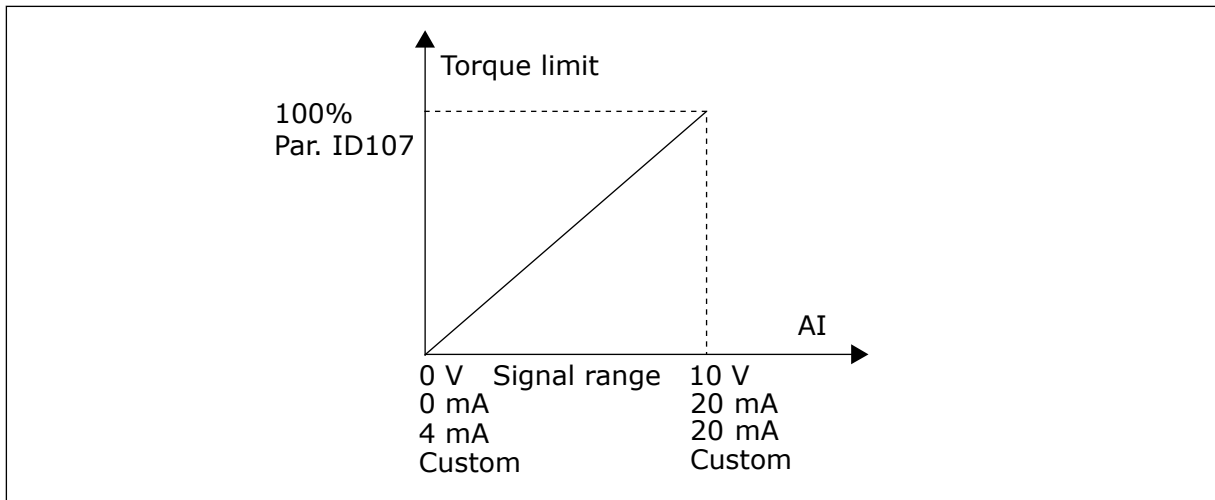

Fig. 50: Scaling of max. motor current

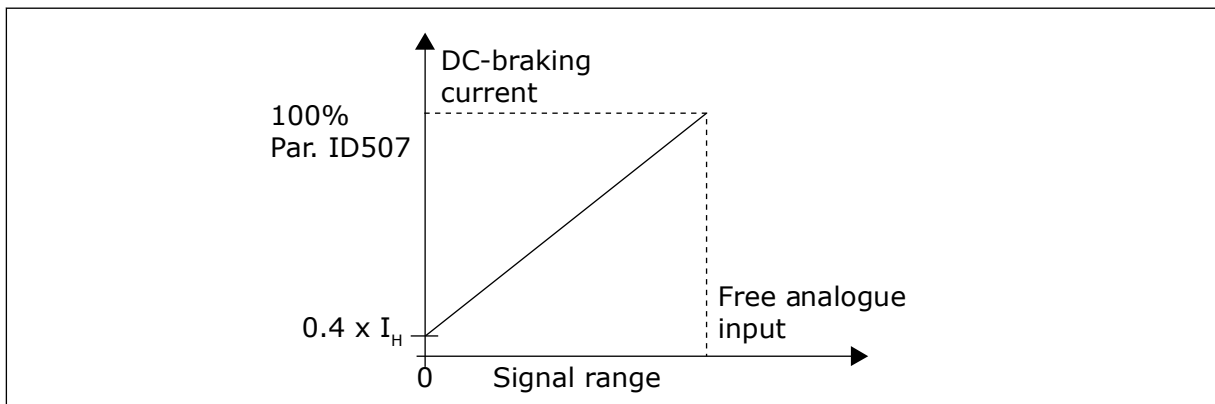

Fig. 51: Reduction of DC braking current

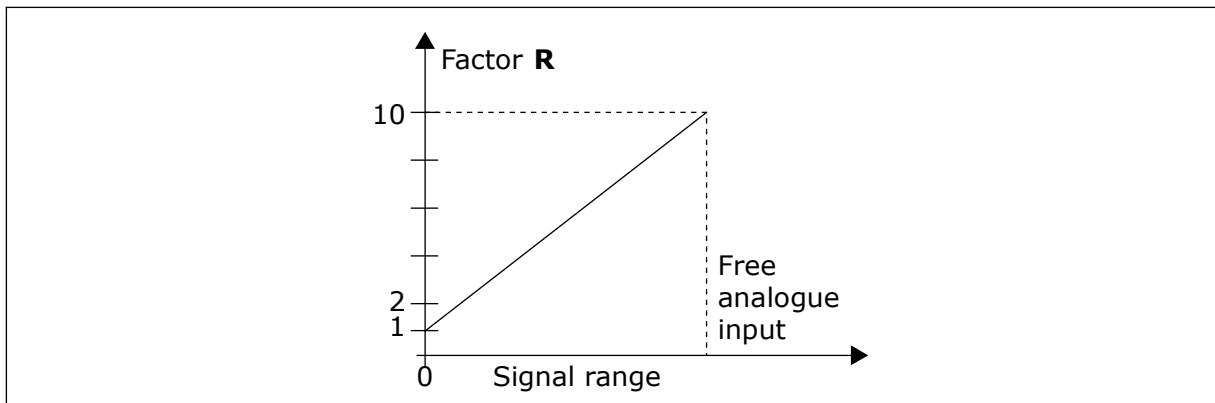

Fig. 52: Reduction of acceleration and deceleration times

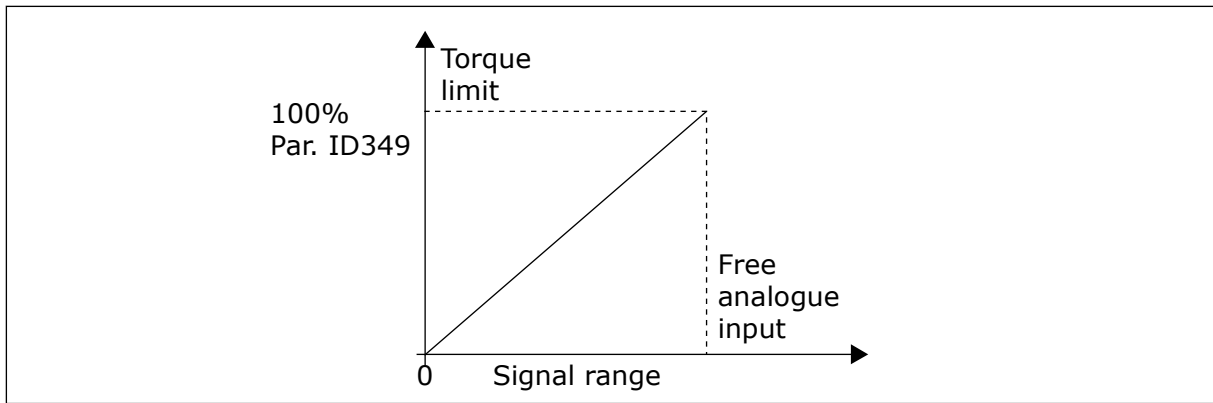

Fig. 53: Reduction of torque supervision limit

363 START/STOP LOGIC SELECTION, PLACE B3 (2.2.15)

Use this parameter to control the start and stop of the drive with the digital signals.

Table 141: Selections for parameter ID363

Selection	DIN3	DIN4	DIN5
0		closed contact = start forward	closed contact = start reverse
	See Fig. 54.		
1		closed contact = start open contact = stop	closed contact = reverse open contact = forward
	See Fig. 55.		
2		closed contact = start, open contact = stop	closed contact = start enabled, open contact = start disabled and drive stopped if running
3 *	Can be programmed for reverse command	closed contact = start pulse	open contact = stop pulse
	See Fig. 56.		
4 **		closed contact = start forward (Rising edge required to start)	closed contact = start reverse (Rising edge required to start)
5 **		closed contact = start (Rising edge required to start) open contact = stop	closed contact = reverse open contact = forward
6 **		closed contact = start (Rising edge required to start) open contact = stop	closed contact = start enabled open contact = start disabled and drive stopped if running

* = 3-wire connection (pulse control)

** = The selections 4 to 6 are used to exclude the possibility of an unintentional start when, for example, power is connected, re-connected after a power failure, after a fault reset, after the drive is stopped by Run Enable (Run Enable = False) or when the control place is changed. The Start/Stop contact must be opened before the motor can be started.

The selections including the text 'Rising edge required to start' are used to exclude the possibility of an unintentional start when, for example, power is connected, re-connected after a power failure, after a fault reset, after the drive is stopped by Run Enable (Run Enable = False) or when the control place is changed from I/O control. The Start/Stop contact must be opened before the motor can be started.

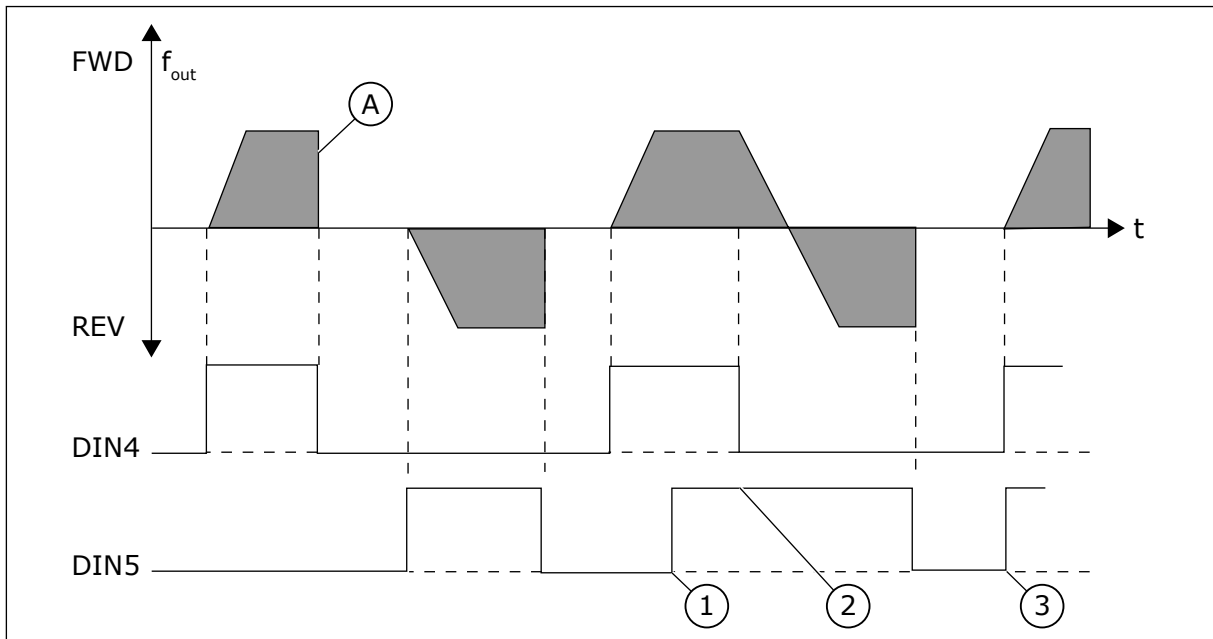

Fig. 54: Start forward/Start reverse

1. The first selected direction has the highest priority.
2. When the DIN4 contact opens the direction of rotation starts the change.
3. Start pulse/ Stop pulse

A) Stop function (ID506) = coasting

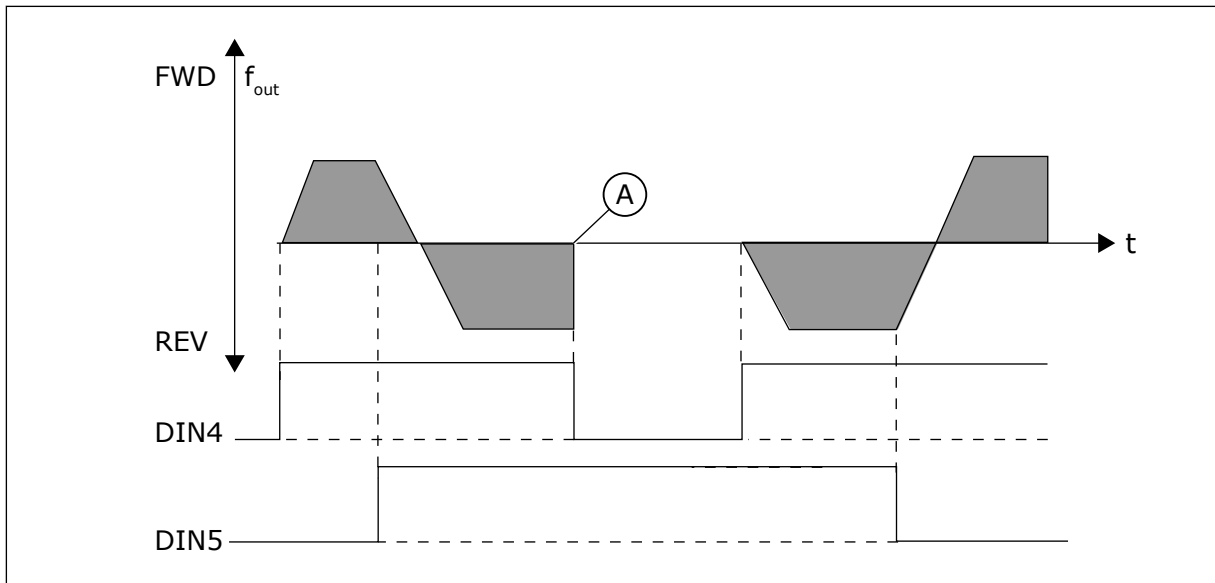

Fig. 55: Start, Stop, Reverse

A) Stop function (ID506) = coasting

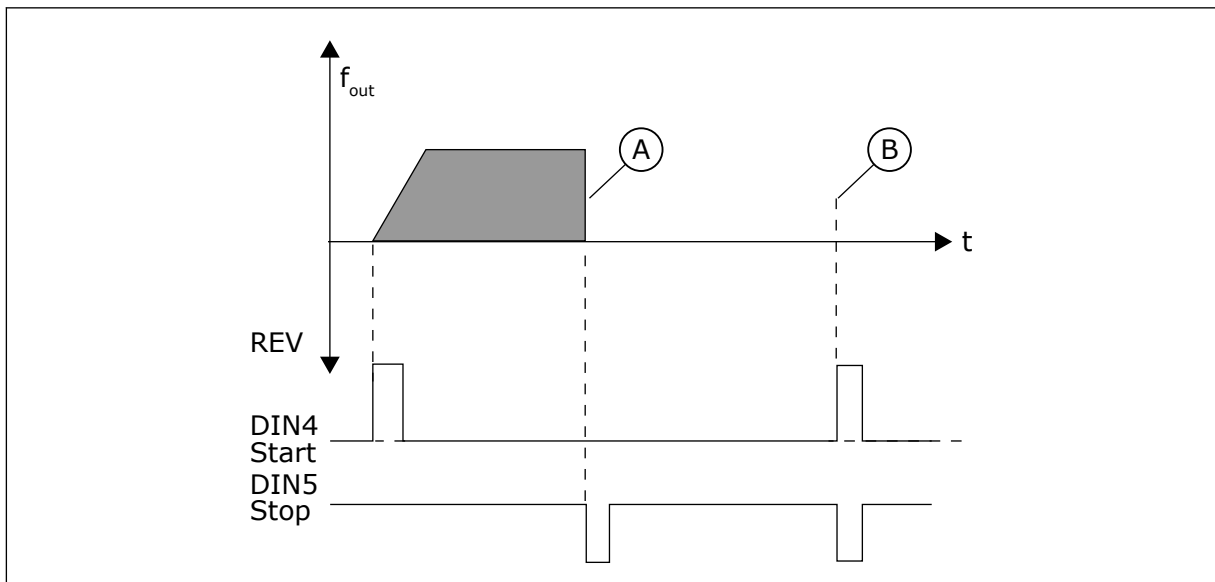

Fig. 56: Start pulse/ Stop pulse

A) Stop function (ID506) = coasting

B) If Start and Stop pulses are simultaneous the Stop pulse overrides the Start pulse

364 REFERENCE SCALING, MINIMUM VALUE, PLACE B3 (2.2.18)

Use this parameter to set additional reference scaling.

365 REFERENCE SCALING, MAXIMUM VALUE, PLACE B3 (2.2.19)

Use this parameter to set additional reference scaling.

See parameters ID303 and ID304 above.

366 EASY CHANGEOVER 5 (2.2.37)

Use this parameter to select copy reference function.

Table 142: Selections for parameter ID366

Selection number	Selection name	Description
0	Keep reference	
1	Copy reference	

If Copy reference has been selected it is possible to switch from direct control to PID control and back without scaling the reference and actual value.

For example: The process is driven with direct frequency reference (Control place I/O B, fieldbus or keypad) to some point and then the control place is switched to one where the PID controller is selected. The PID control starts to maintain that point.

It is also possible to change the control source back to direct frequency control. In this case, the output frequency is copied as the frequency reference. If the destination place is Keypad the run status (Run/Stop, Direction and Reference) will be copied.

The changeover is smooth when the reference of the destination source comes from the Keypad or an internal motor potentiometer (parameter ID332 [PID Ref.] = 2 or 4, ID343 [I/O B Ref] = 2 or 4, par. ID121 [Keypad Ref] = 2 or 4 and ID122 [Fieldbus Ref]= 2 or 4.

367 MOTOR POTENTIOMETER MEMORY RESET (FREQUENCY REFERENCE) 3567 (2.2.23, 2.2.28, 2.2.1.3, 2.2.1.16)

Use this parameter to set the logic for the resetting of the frequency reference of the motor potentiometer.

Table 143: Selections for parameter ID367

Selection number	Selection name	Description
0	No reset	
1	Memory reset in stop and powerdown	
2	Memory reset in powerdown	

370 MOTOR POTENTIOMETER MEMORY RESET (PID REFERENCE) 57 (2.2.29, 2.2.1.17)

Use this parameter to set the logic for the resetting of the PID reference of the motor potentiometer.

Table 144: Selections for parameter ID370

Selection number	Selection name	Description
0	No reset	
1	Memory reset in stop and powerdown	
2	Memory reset in powerdown	

371 PID REFERENCE 2 (PLACE A ADDITIONAL REFERENCE) 7 (2.2.1.4)

Use this parameter to select the reference place for PID controller reference when PID reference is activated.

If the PID reference 2 enable input function (ID330)= TRUE, this parameter defines which reference place is selected as PID controller reference.

Table 145: Selections for parameter ID371

Selection number	Selection name	Description
0	AI1 reference	(terminals 2 and 3, e.g. potentiometer)
1	AI2 reference	(terminals 5 and 6, e.g. transducer)
2	AI3 reference	
3	AI4 reference	
4	PID reference 1 from keypad	
5	Reference from Fieldbus (FBProcessDataIN3)	see Chapter 9.7 <i>Fieldbus control parameters (IDs 850 to 859)</i>
6	Motor potentiometer	If value 6 is selected for this parameter, the functions Motor potentiometer DOWN and Motor potentiometer UP must be connected to digital inputs (parameters ID417 and ID418).
7	PID reference 2 from keypad	

372 SUPERVISED ANALOGUE INPUT 7 (2.3.2.13)

Use this parameter to select the analogue input for which you want to set the limit supervision function.

Table 146: Selections for parameter ID372

Selection number	Selection name	Description
0	Analogue input 1 (AI1)	
1	Analogue input 2 (AI2)	

373 ANALOGUE INPUT LIMIT SUPERVISION 7 (2.3.2.14)

Use this parameter select the limit supervision function for the selected analogue input.

If the value of the selected analogue input goes under/over the set supervision value (parameter ID374) this function generates a message through the digital output or the relay outputs depending on to which output the analogue input supervision function (parameter ID463) is connected.

Table 147: Selections for parameter ID373

Selection number	Selection name	Description
0	No supervision	
1	Low limit supervision	
2	High limit supervision	

374 ANALOGUE INPUT SUPERVISED VALUE 7 (2.3.2.15)

Use this parameter to set the limit supervision value for the selected analogue input when you activate the limit supervision function.

The value of the selected analogue input to be supervised by parameter ID373.

375 ANALOGUE OUTPUT OFFSET 67 (2.3.5.7, 2.3.3.7)

Use this parameter to add offset to the analogue output.

Add -100.0 to 100.0% to the analogue output signal.

376 PID SUM POINT REFERENCE (PLACE A DIRECT REFERENCE) 5 (2.2.4)

Use this parameter to select additional reference sources to the PID controller output when PID controller is used.

Table 148: Selections for parameter ID376

Selection number	Selection name	Description
0	No additional reference	(Direct PID output value)
1	PID output + AI1 reference from terminals 2 and 3 (e.g. potentiometer)	
2	PID output + AI2 reference from terminals 4 and 5 (e.g. transducer)	
3	PID output + PID keypad reference	
4	PID output + Fieldbus reference (FBSpeedReference)	
5	PID output + Motor potentiometer reference	
6	PID output + Fieldbus + PID output (ProcessDataIN3)	see Chapter 9.7 Fieldbus control parameters (IDs 850 to 859)
7	PID output + Motor potentiometer	

If value 7 is selected for this parameter, the values of parameters ID319 and ID301 are automatically set to 13.

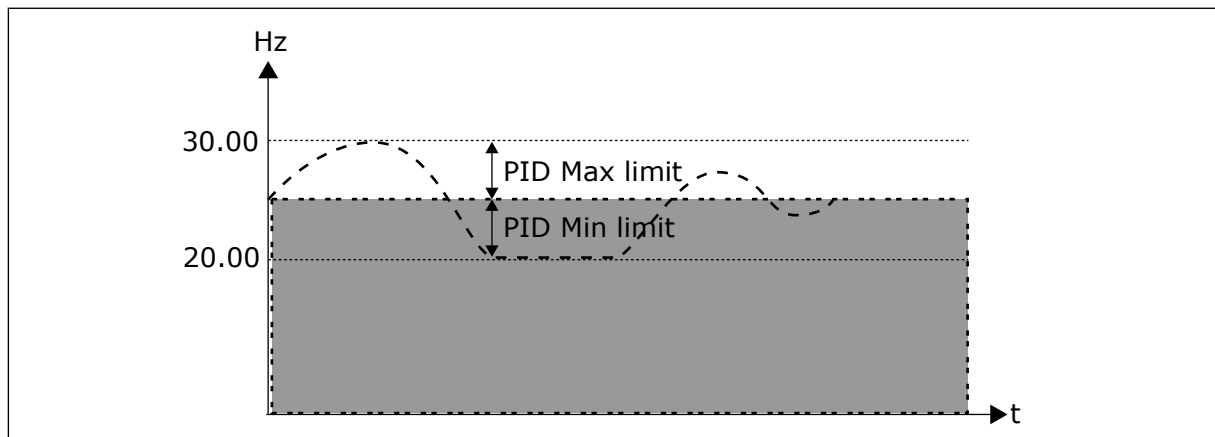

Fig. 57: PID sum point reference



NOTE!

The maximum and minimum limits illustrated in the picture limit only the PID output, no other outputs.

377 AI1 SIGNAL SELECTION * 234567 (2.2.8, 2.2.3, 2.2.15, 2.2.2.1)

Use this parameter to connect the AI signal to the analogue input of your choice.

For more information about the TTF programming method, see Chapter 9.9 "Terminal to function" (TTF) programming principle.

384 AI1 JOYSTICK HYSTERESIS 6 (2.2.2.8)

Use this parameter to set the joystick hysteresis.

This parameter defines the joystick hysteresis between 0 and 20 %.

When the joystick or potentiometer control is turned from reverse to forward, the output frequency falls linearly to the selected minimum frequency (joystick/ potentiometer in middle position) and stays there until the joystick/potentiometer is turned towards the forward command. It depends on the amount of joystick hysteresis defined with this parameter, how much the joystick/potentiometer must be turned to start the increase of the frequency towards the selected maximum frequency.

If the value of this parameter is 0, the frequency starts to increase linearly immediately when the joystick/potentiometer is turned towards the forward command from the middle position. When the control is changed from forward to reverse, the frequency follows the same pattern the other way round.

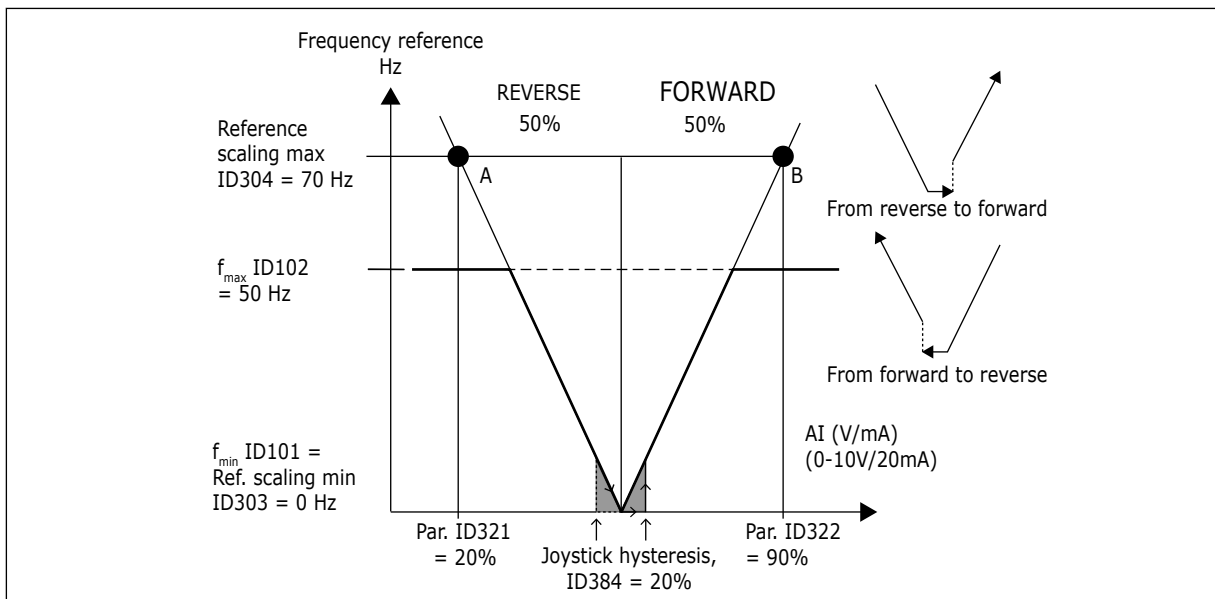

Fig. 58: An example of joystick hysteresis. In this example, the value of parameter ID385 (Sleep limit) = 0

385 AI1 SLEEP LIMIT 6 (2.2.2.9)

Use this parameter to set the sleep limit. The AC drive stops automatically if the AI signal level falls below the value set with this parameter.

See also parameter ID386 and Fig. 59.

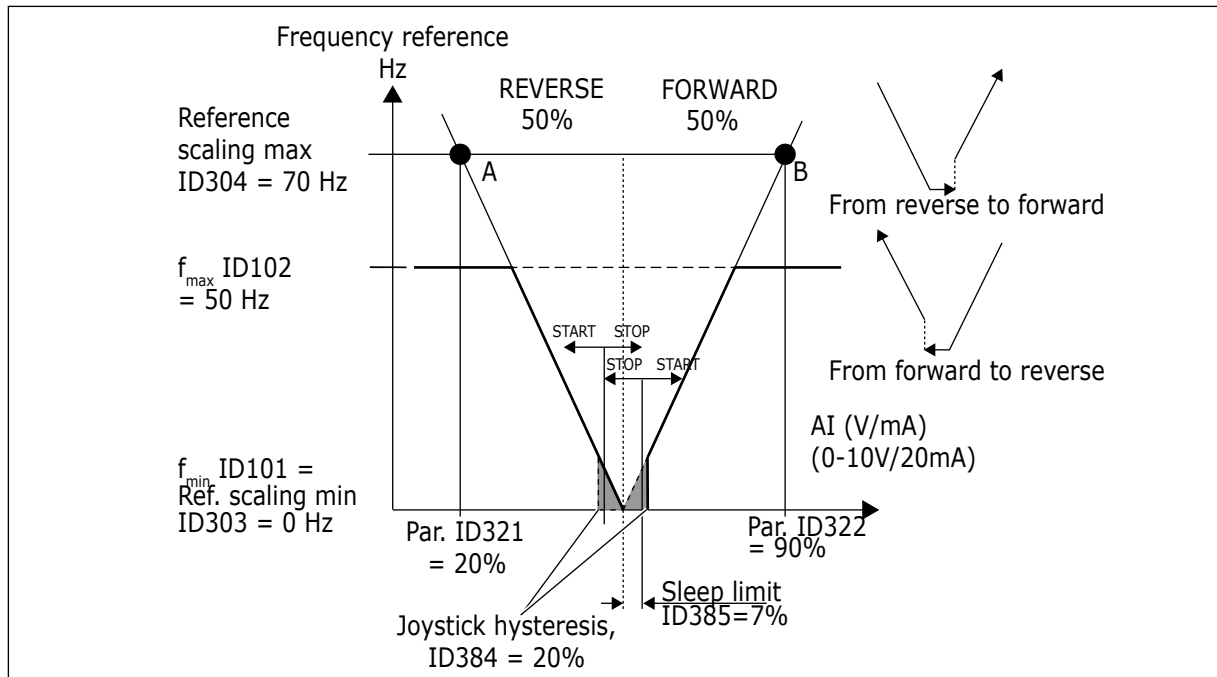

Fig. 59: Example of sleep limit function

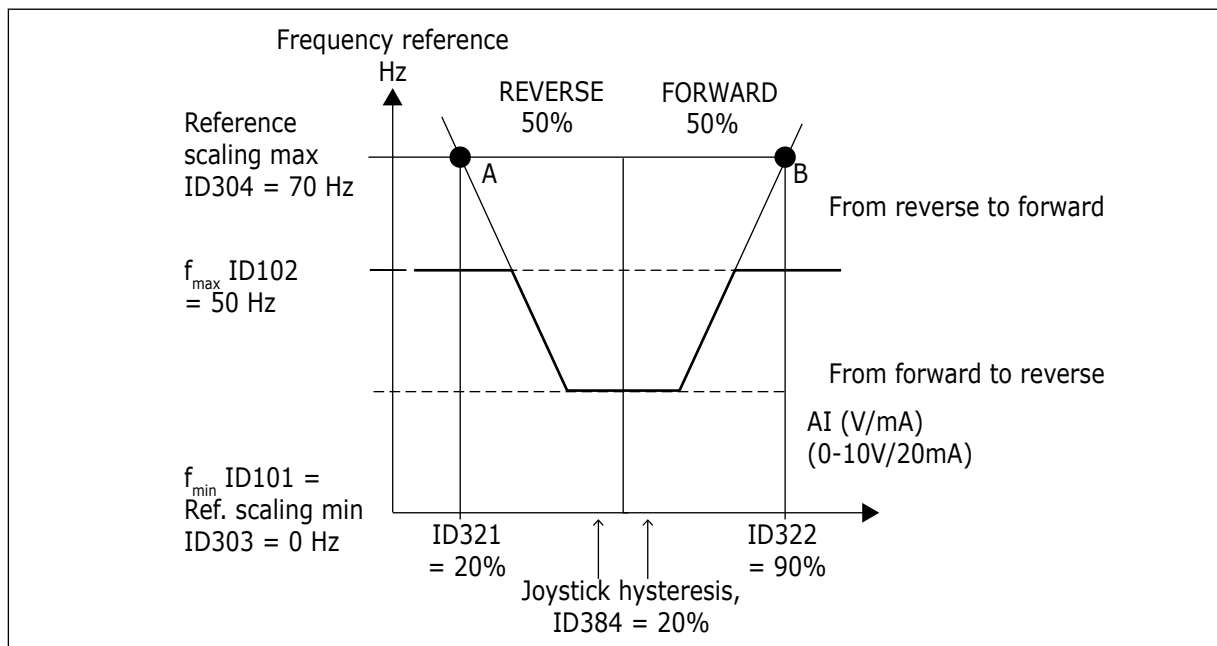

Fig. 60: Joystick hysteresis with minimum frequency at 35Hz

386 AI1 SLEEP DELAY 6 (2.2.2.10)

Use this parameter to set the time the analogue input signal must stay under the sleep limit before the AC drive stops.

This parameter defines the time the analogue input signal has to stay under the sleep limit determined with parameter ID385 in order to stop the AC drive.

388 AI2 SIGNAL SELECTION * 234567 (2.2.9, 2.2.21, 2.2.3.1)

Use this parameter to connect the AI signal to the analogue input of your choice.

Connect the AI2 signal to the analogue input of your choice with this parameter. For more information about the TTF programming method, see Chapter 9.9 "Terminal to function" (TTF) programming principle.

393 AI2 REFERENCE SCALING, MINIMUM VALUE 6 (2.2.3.6)

Use this parameter to set additional reference scaling.

394 AI2 REFERENCE SCALING, MAXIMUM VALUE 6 (2.2.3.7)

Use this parameter to set additional reference scaling.

If the values of both ID393 and ID394 are zero scaling is set off. The minimum and maximum frequencies are used for scaling. See parameters ID303 and ID304

395 AI2 JOYSTICK HYSTERESIS 6 (2.2.3.8)

Use this parameter to set the joystick hysteresis.

This parameter defines the joystick dead zone between 0 and 20%. See ID384.

396 AI2 SLEEP LIMIT 6 (2.2.3.9)

Use this parameter to set the sleep limit. The AC drive stops automatically if the AI signal level falls below the value set with this parameter.

See also parameter ID397 and *Fig. 60 Joystick hysteresis with minimum frequency at 35Hz.*

See ID385.

397 AI2 SLEEP DELAY 6 (2.2.3.10)

Use this parameter to set the time the analogue input signal must stay under the sleep limit before the AC drive stops.

399 SCALING OF CURRENT LIMIT 6 (2.2.6.1)

Use this parameter to select the signal to adjust the maximum value of the motor current.

Table 149: Selections for parameter ID399

Selection number	Selection name	Description
0	Not used	
1	AI1	
2	AI2	
3	AI3	
4	AI4	
5	Fieldbus (FBProcessDataIN2)	See Chapter 9.7 <i>Fieldbus control parameters (IDs 850 to 859)</i> .

This signal will adjust the maximum motor current between 0 and Motor current limit (ID107).

400 SCALING OF DC-BRAKING CURRENT 6 (2.2.6.2)

Use this parameter to select the signal to adjust the DC-braking current.

See parameter ID399 for the selections.

DC-braking current can be reduced with the free analogue input signal between zero current and the current set with parameter ID507.

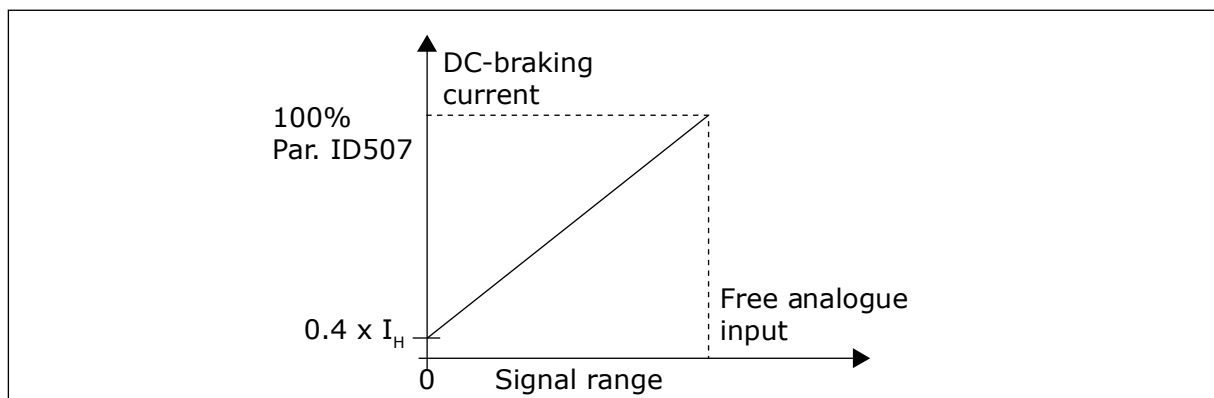

Fig. 61: Scaling of DC-braking current

401 SCALING OF ACCELERATION AND DECELERATION TIMES 6 (2.2.6.3)

Use this parameter to select the signal to adjust the acceleration and deceleration times.

See parameter ID399.

Acceleration and deceleration times can be reduced with the free analogue input signal according to the following formulas:

Reduced time = set acc./deceler. time (parameters ID103, ID104; ID502, ID503) divided by the factor R from *Fig. 62*.

Analogue input level zero corresponds to ramp times set by parameters. Maximum level means a tenth of value set by parameter.

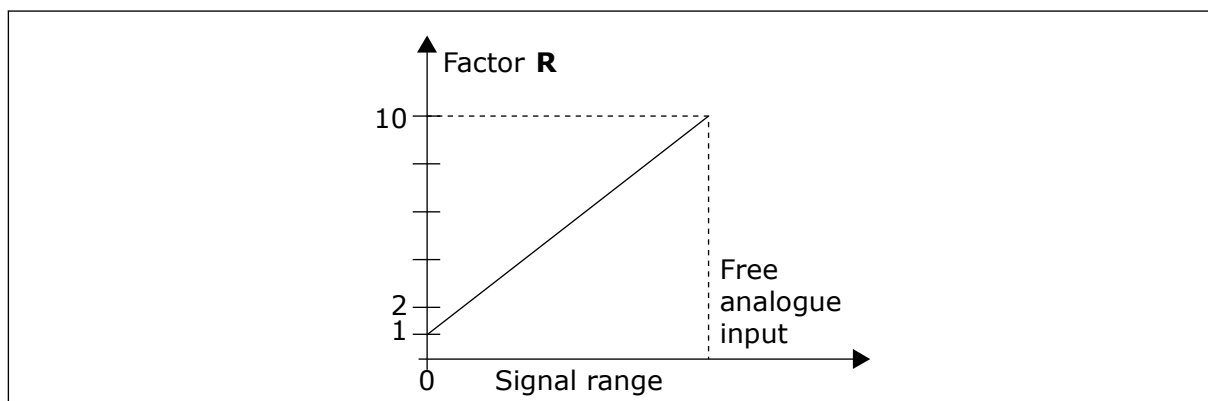

Fig. 62: Reducing of acceleration and deceleration times

402 SCALING OF TORQUE SUPERVISION LIMIT 6 (2.2.6.4)

Use this parameter to select the signal to adjust the torque supervision limit.

See ID399.

The set torque supervision limit can be reduced with the free analogue input signal between 0 and the set supervision limit, ID349.

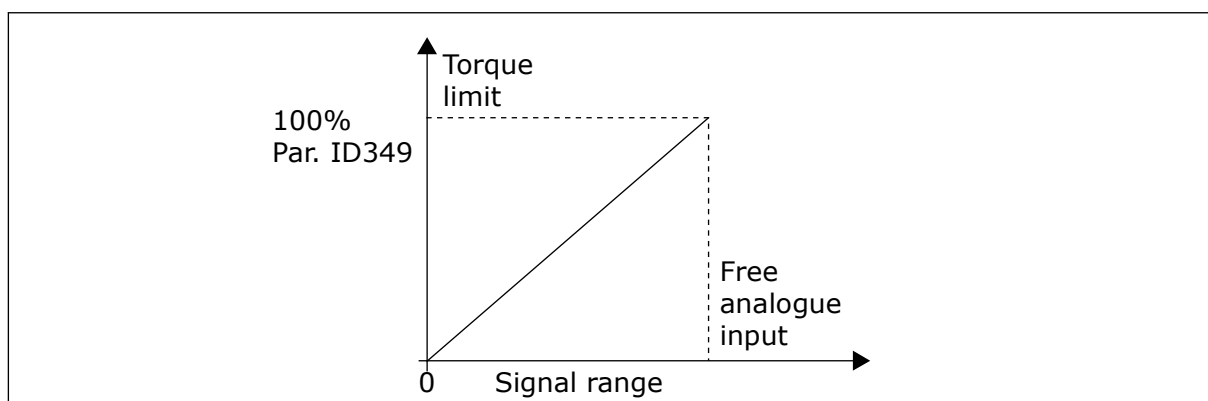

Fig. 63: Reducing torque supervision limit

403 START SIGNAL * 16 (2.2.7.1)

Use this parameter to select the digital input signal (Control Signal 1) that starts and stops the drive when the control place is I/O A (FWD).

Default programming A.1.

404 START SIGNAL * 26 (2.2.7.2)

Use this parameter to select the digital input signal (Control Signal 2) that starts and stops the drive when the control place is I/O A (REV).

Default programming A.2.

405 EXTERNAL FAULT (CLOSE) * 67 (2.2.7.11, 2.2.6.4)

Use this parameter to select the digital input signal that activates an external fault.

Contact closed: Fault (F51) is displayed and motor stopped.

406 EXTERNAL FAULT (OPEN) * 67 (2.2.7.12, 2.2.6.5)

Use this parameter to select the digital input signal that activates an external fault.

Contact open: Fault (F51) is displayed and motor stopped.

407 RUN ENABLE * 67 (2.2.7.3, 2.2.6.6)

Use this parameter to select the digital input signal that sets the drive to Ready state.

When the contact is OPEN, the start of the motor is disabled.

When the contact is CLOSED, the start of the motor is enabled.

To stop, the drive obeys the value of parameter ID506. The follower drive will always coast to stop.

408 ACCELERATION/DECELERATION TIME SELECTION * 67 (2.2.7.13, 2.2.6.7)

Use this parameter to select the digital input signal that selects the acceleration/ deceleration time 1 or 2.

When the contact is OPEN, the Acceleration/Deceleration time 1 selected

When the contact is CLOSED, the Acceleration/Deceleration time 2 selected

Set Acceleration/Deceleration times with parameters ID103 and ID104 and the alternative ramp times with ID502 and ID503.

409 CONTROL FROM I/O TERMINAL * 67 (2.2.7.18, 2.2.6.8)

Use this parameter to select the digital input signal that switches the control place and the frequency reference source to I/O terminal (from any control place).

Contact closed: Force control place to I/O terminal

This input has priority over parameters ID410 and ID411.

410 CONTROL FROM KEYPAD * 67 (2.2.7.19, 2.2.6.9)

Use this parameter to select the digital input signal that switches the control place and the frequency reference source to Keypad (from any control place).

Contact closed: Force control place to keypad

This input has priority over parameter ID411 but preceded in priority by ID409.

411 CONTROL FROM FIELDBUS * 67 (2.2.7.20, 2.2.6.10)

Use this parameter to select the digital input signal that switches the control place and the frequency reference source to Fieldbus (from I/O A, I/O B or Local control).

Contact closed: Force control place to fieldbus

This input is preceded in priority by parameters ID409 and ID410.

**NOTE!**

When the control place is forced to change the values of Start/Stop, Direction and Reference valid in the respective control place are used.

The value of parameter ID125 (Keypad Control Place) does not change.

When the input opens the control place is selected according to keypad control parameter ID125.

412 REVERSE * 67 (2.2.7.4, 2.2.6.11)

Use this parameter to select the digital input signal that changes the direction when Start signal 2 is used for other purposes.

Contact open: Direction forward
Contact closed: Direction reverse

This command is active when Start signal 2 (ID404) is used for other purposes.

413 JOGGING SPEED * 67 (2.2.7.16, 2.2.6.12)

Use this parameter to select the digital input signal that selects jogging speed for the frequency reference.

Contact closed: Jogging speed selected for frequency reference

See parameter ID124.

Default programming: A.4.

414 FAULT RESET * 67 (2.2.7.10, 2.2.6.13)

Use this parameter to select the digital input signal that resets all active faults.

CLOSED = Resets all active faults.

415 ACCELERATION / DECELERATION PROHIBITED * 67 (2.2.7.14, 2.2.6.14)

Use this parameter to select the digital input signal that prevents the acceleration and the deceleration of the drive.

No acceleration or deceleration is possible until the contact is open.

416 DC-BRAKING * 67 (2.2.7.15, 2.2.6.15)

Use this parameter to select the digital input signal that starts DC braking in the STOP mode.

Contact closed: In STOP mode, the DC braking operates until the contact is opened.

See ID1080.

417 MOTOR POTENTIOMETER DOWN * 67 (2.2.7.8, 2.2.6.16)

Use this parameter to decrease the output frequency with a digital input signal.

Contact closed: Motor potentiometer reference DECREASES until the contact is opened.

418 MOTOR POTENTIOMETER UP * 67 (2.2.7.9, 2.2.6.17)

Use this parameter to increase the output frequency with a digital input signal.

Contact closed: Motor potentiometer reference INCREASES until the contact is opened.

419 PRESET SPEED * 16 (2.2.7.5)

Use this parameter to select the digital input signal that is used as a selector for the preset frequencies.

420 PRESET SPEED * 26 (2.2.7.6)

Use this parameter to select the digital input signal that is used as a selector for the preset frequencies.

421 PRESET SPEED * 36 (2.2.7.7)

Use this parameter to select the digital input signal that is used as a selector for the preset frequencies.

422 AI1/AI2 SELECTION * 6 (2.2.7.17)

Use this parameter to select the analogue input signal that is used for the frequency reference.

With value 14 selected for parameter ID117, this parameter allows you to select either AI1 or AI2 signal for the frequency reference.

423 START A SIGNAL * 7 (2.2.6.1)

Use this parameter to select the digital input signal that starts and stops the drive when the control place is I/O A.

Default programming: A.1

424 START B SIGNAL * 7 (2.2.6.2)

Use this parameter to select the digital input signal that starts and stops the drive when the control place is I/O B.

Default programming: A.4

425 CONTROL PLACE A/B SELECTION * 7 (2.2.6.3)

Use this parameter to select the digital input signal that selects the control place I/O A or I/O B.

Contact open:Control place A
Contact closed:Control place B
Default programming: A.6

426 AUTOCHANGE 1 INTERLOCK * 7 (2.2.6.18)

Use this parameter to select the digital input signal that is used as interlock signal for the Multi-Pump system.

Contact closed:Interlock of autochange drive 1 or auxiliary drive 1 activated.

Default programming: A.2.

427 AUTOCHANGE 2 INTERLOCK * 7 (2.2.6.19)

Use this parameter to select the digital input signal that is used as interlock signal for the Multi-Pump system.

Contact closed:Interlock of autochange drive 2 or auxiliary drive 2 activated.

Default programming: A.3.

428 AUTOCHANGE 3 INTERLOCK * 7 (2.2.6.20)

Use this parameter to select the digital input signal that is used as interlock signal for the Multi-Pump system.

Contact closed:Interlock of autochange drive 3 or auxiliary drive 3 activated.

429 AUTOCHANGE 4 INTERLOCK * 7 (2.2.6.21)

Use this parameter to select the digital input signal that is used as interlock signal for the Multi-Pump system.

Contact closed:Interlock of autochange drive 4 or auxiliary drive 4 activated.

430 AUTOCHANGE 5 INTERLOCK * 7 (2.2.6.22)

Use this parameter to select the digital input signal that is used as interlock signal for the Multi-Pump system.

Contact closed:Interlock of autochange drive 5 activated.

431 PID REFERENCE * 27 (2.2.6.23)

Use this parameter to select the source of the PID setpoint signal.

Contact open: PID controller reference selected with parameter ID332.

Contact closed: PID controller keypad reference 2 selected with parameter ID371.

432 READY * 67 (2.3.3.1, 2.3.1.1)

Use this parameter to select a digital output for the ready status.

433 RUN * 67 (2.3.3.2, 2.3.1.2)

Use this parameter to select a digital output for the run status.

434 FAULT * 67 (2.3.3.3, 2.3.1.3)

Use this parameter to select a digital output for the fault status.

435 INVERTED FAULT * 67 (2.3.3.4, 2.3.1.4)

Use this parameter to select a digital output for the fault inverted status.

436 WARNING * 67 (2.3.3.5, 2.3.1.5)

Use this parameter to select a digital output for the warning status.

437 EXTERNAL FAULT OR WARNING * 67 (2.3.3.6, 2.3.1.6)

Use this parameter to select a digital output for the external fault status.

Fault or warning depending on parameter ID701.

438 REFERENCE FAULT OR WARNING * 67 (2.3.3.7, 2.3.1.7)

Use this parameter to select a digital output for the AI reference fault status.

Fault or warning depending on parameter ID700.

439 DRIVE OVERTEMPERATURE WARNING * 67 (2.3.3.8, 2.3.1.8)

Use this parameter to select a digital output for the over temperature fault status.

The heatsink temperature exceeds the warning limit.

440 REVERSE * 67 (2.3.3.9, 2.3.1.9)

Use this parameter to select a digital output for the reverse status.

441 UNREQUESTED DIRECTION * 67 (2.3.3.10, 2.3.1.10)

Use this parameter to select a digital output for the direction difference status.

Motor rotation direction is different from the requested one.

442 AT SPEED * 67 (2.3.3.11, 2.3.1.11)

Use this parameter to select a digital output for the motor running at reference speed status.

The output frequency has reached the set reference.

Hysteresis is equal to motor nominal slip with induction motors and to 1.00 Hz with PMS motors.

443 JOGGING SPEED * 67 (2.3.3.12, 2.3.1.12)

Use this parameter to select a digital output for the jogging speed status.

444 I/O CONTROL PLACE ACTIVE * 67 (2.3.3.13, 2.3.1.13)

Use this parameter to select a digital output for the external control place status.

445 EXTERNAL BRAKE CONTROL * 67 (2.3.3.14, 2.3.1.14)

Use this parameter to select a digital output for the external brake control status.

See Chapter 9.3 *External brake control with additional limits (IDs 315, 316, 346 to 349, 352, 353)* for details.

Example: R01 on OPTA2 board:

Brake function ON: Terminals 22-23 are closed (relay is energized).

Brake function OFF: Terminals 22-23 are open (relay not energized).

**NOTE!**

When power from control board is removed terminals 22-23 open.

When using the Master Follower function, the follower drive will open the brake at the same time as the Master does even if the Follower's conditions for brake opening have not been met.

446 EXTERNAL BRAKE CONTROL, INVERTED * 67 (2.3.3.15, 2.3.1.15)

Use this parameter to select a digital output for the external brake control inverted status.

See Chapter 9.3 *External brake control with additional limits (IDs 315, 316, 346 to 349, 352, 353)* for details.

Example: R01 on OPTA2 board:

Brake function ON: Terminals 22-23 are open (relay not energized).

Brake function OFF: Terminals 22-23 are closed (relay is energized).

When using the Master Follower function, the follower drive will open the brake at the same time as the Master does even if the Follower's conditions for brake opening have not been met.

447 OUTPUT FREQUENCY LIMIT 1 SUPERVISION * 67 (2.3.3.16, 2.3.1.16)

Use this parameter to select a digital output for the frequency output supervision 1 status.

The output frequency goes outside the set supervision low limit/high limit (see parameters ID315 and ID316).

448 OUTPUT FREQUENCY LIMIT 2 SUPERVISION * 67 (2.3.3.17, 2.3.1.17)

Use this parameter to select a digital output for the frequency output supervision 2 status.

The output frequency goes outside the set supervision low limit/high limit (see parameters ID346 and ID347).

449 REFERENCE LIMIT SUPERVISION * 67 (2.3.3.18, 2.3.1.18)

Use this parameter to select a digital output for the reference limit supervision status.

Active reference goes beyond the set supervision low limit/high limit (see parameters ID350 and ID351).

450 TEMPERATURE LIMIT SUPERVISION * 67 (2.3.3.19, 2.3.1.19)

Use this parameter to select a digital output for the temperature limit supervision status.

The AC drive heatsink temperature goes beyond the set supervision limits (see parameters ID354 and ID355).

451 TORQUE LIMIT SUPERVISION * 67 (2.3.3.20, 2.3.1.20)

Use this parameter to select a digital output for the torque limit supervision status.

The motor torque goes beyond the set supervision limits (see parameters ID348 and ID349).

452 THERMISTOR FAULT OR WARNING * 67 (2.3.3.21, 2.3.1.21)

Use this parameter to select a digital output for the motor thermal fault status.

Motor thermistor initiates a overtemperature signal which can be led to a digital output.

**NOTE!**

This function requires an AC drive equipped with a thermistor input.

453 ANALOGUE INPUT SUPERVISION LIMIT * 6 (V2.3.3.22)

Use this parameter to select a digital output for the analogue input supervision status.

The selected analogue input signal goes beyond the set supervision limits (see parameters ID372, ID373 and ID374).

454 MOTOR REGULATOR ACTIVATION * 67 (2.3.3.23, 2.3.1.23)

Use this parameter to select a digital output for the motor regulator status.

One of the limit regulators (current limit, torque limit) has been activated.

455 FIELD BUS DIGITAL INPUT 1 * 67 (2.3.3.24, 2.3.1.24)

Use this parameter to select a digital output for the FBFixedControlWord B3 status.

456 FIELD BUS DIGITAL INPUT 2 * 67 (2.3.3.25, 2.3.1.25)

Use this parameter to select a digital output for the FBFixedControlWord B4 status.

457 FIELD BUS DIGITAL INPUT 3 * 67 (2.3.3.26, 2.3.1.26)

Use this parameter to select a digital output for the FBFixedControlWord B5 status.

See the fieldbus manual for details. See also ID169 and ID170.

458 AUTOCHANGE 1/AUXILIARY DRIVE 1 CONTROL 7 (2.3.1.27)

Use this parameter to select a digital output for the autochange/auxiliary drive status.

Default programming: B.1

459 AUTOCHANGE 2/AUXILIARY DRIVE 2 CONTROL * 7 (2.3.1.28)

Use this parameter to select a digital output for the autochange/auxiliary drive status.

Control signal for autochange/auxiliary drive 2.

Default programming: B.2

460 AUTOCHANGE 3/AUXILIARY DRIVE 3 CONTROL * 7 (2.3.1.29)

Use this parameter to select a digital output for the autochange/auxiliary drive status.

Control signal for autochange/auxiliary drive 3. If three (or more) auxiliary drives are used, we recommend to connect nr 3, too, to a relay output. Since the OPTA2 board only has two relay outputs it is advisable to purchase an I/O expander board with extra relay outputs (e.g. VACON® OPTB5).

461 AUTOCHANGE 4/AUXILIARY DRIVE 4 CONTROL * 7 (2.3.1.30)

Use this parameter to select a digital output for the autochange/auxiliary drive status.

Control signal for autochange/auxiliary drive 4. If three (or more) auxiliary drives are used, we recommend to connect nr 3 and 4, too, to a relay output. Since the OPTA2 board only has two relay outputs it is advisable to purchase an I/O expander board with extra relay outputs (e.g. VACON® OPTB5).

462 AUTOCHANGE 5 CONTROL * 7 (2.3.1.31)

Use this parameter to select a digital output for the autochange status.

Control signal for autochange drive 5.

463 ANALOGUE INPUT SUPERVISION LIMIT * 7 (2.3.1.22)

Use this parameter to select a digital output for the analogue input supervision status.

The selected analogue input signal goes beyond the set supervision limits (see parameters ID372, ID373 and ID374).

464 ANALOGUE OUTPUT 1 SIGNAL SELECTION * 234567 (2.3.1, 2.3.5.1, 2.3.3.1)

Use this parameter to connect the analogue output signal to the analogue output of your choice.

For more information about the TTF programming method, see Chapter 9.9 "Terminal to function" (TTF) programming principle.

471 ANALOGUE OUTPUT 2 SIGNAL SELECTION * 234567 (2.3.12, 2.3.22, 2.3.6.1, 2.3.4.1)

Use this parameter to connect the analogue output signal to the analogue output of your choice.

For more information about the TTF programming method, see Chapter 9.9 "Terminal to function" (TTF) programming principle.

472 ANALOGUE OUTPUT 2 FUNCTION 234567 (2.3.13, 2.3.23, 2.3.6.2, 2.3.4.2)

Use this parameter to select the function for the analogue output signal.

473 ANALOGUE OUTPUT 2 FILTER TIME 234567 (2.3.13, 2.3.23, 2.3.6.3, 2.3.4.3)

Use this parameter to set the filtering time of the analogue output signal.

474 ANALOGUE OUTPUT 2 INVERSION 234567 (2.3.15, 2.3.25, 2.3.6.4, 2.3.4.4)

Use this parameter to invert the analogue output signal.

475 ANALOGUE OUTPUT 2 MINIMUM 234567 (2.3.16, 2.3.26, 2.3.6.5, 2.3.4.5)

Use this parameter to set the minimum value of the analogue output signal.

476 ANALOGUE OUTPUT 2 SCALING 234567 (2.3.17, 2.3.27, 2.3.6.6, 2.3.4.6)

Use this parameter to set the scaling factor for the analogue output.

For more information on these five parameters, see the corresponding parameters for the analogue output 1 (IDs 307-311).

477 ANALOGUE OUTPUT 2 OFFSET 67 (2.3.6.7, 2.3.4.7)

Use this parameter to add offset to the analogue output.

Add -100.0 to 100.0% to the analogue output.

478 ANALOGUE OUTPUT 3, SIGNAL SELECTION * 67 (2.3.7.1, 2.3.5.1)

Use this parameter to connect the analogue output signal to the analog output of your choice.

See ID464.

479 ANALOGUE OUTPUT 3, FUNCTION 67 (2.3.7.2, 2.3.5.2)

Use this parameter to select the function for the analogue output signal.

See ID307.

480 ANALOGUE OUTPUT 3, FILTER TIME 67 (2.3.7.3, 2.3.5.3)

Use this parameter to set the filtering time of the analogue output signal.

Setting this parameter value 0 will deactivate filtering. See ID308.

481 ANALOGUE OUTPUT 3 INVERSION 67 (2.3.7.4, 2.3.5.4)

Use this parameter to invert the analogue output signal.

See ID309.

482 ANALOGUE OUTPUT 3 MINIMUM 67 (2.3.7.5, 2.3.5.5)

Use this parameter to set the minimum value of the analogue output signal.

Defines the signal minimum to either 0 mA or 4 mA (living zero). See ID310.

483 ANALOGUE OUTPUT 3 SCALING 67 (2.3.7.6, 2.3.5.6)

Use this parameter to set the scaling factor for the analogue output.

Value 200% will double the output. See ID311.

484 ANALOGUE OUTPUT 3 OFFSET 67 (2.3.7.7, 2.3.5.7)

Use this parameter to add offset to the analogue output.

Add -100.0 to 100.0% to the analogue output signal. See ID375.

485 SCALING OF MOTORING TORQUE LIMIT 6 (2.2.6.5)

Use this parameter to select the signal that adjusts the maximum motor torque limit.

Table 150: Selections for parameter ID485

Selection number	Selection name	Description
0	Not used	
1	AI1	
2	AI2	
3	AI3	
4	AI4	
5	Fieldbus [FBProcessDataIN2]	See Chapter 9.7 <i>Fieldbus control parameters (IDs 850 to 859)</i>

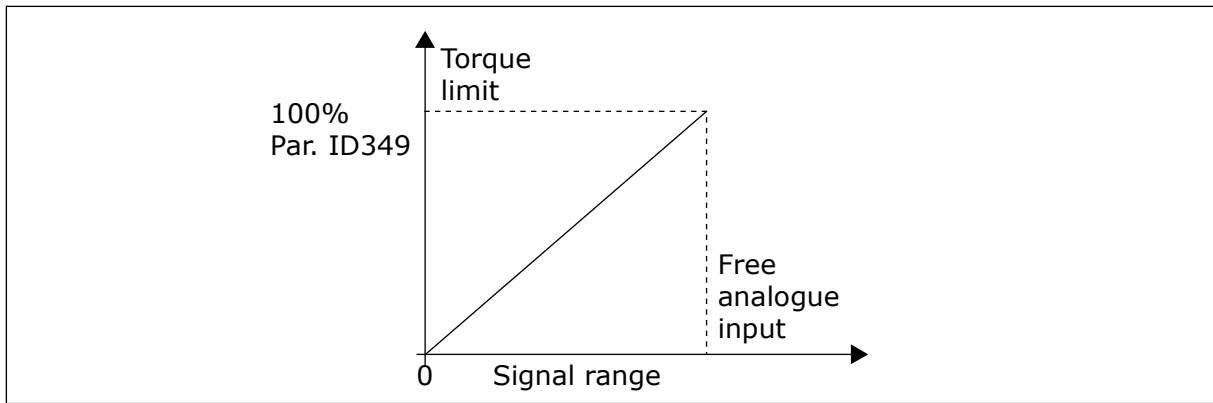

Fig. 64: Scaling of motoring torque limit

486 DIGITAL OUTPUT 1 SIGNAL SELECTION * 6 (2.3.1.1)

Use this parameter to connect the digital output signal to the digital output of your choice.

For more information about the TTF programming method, see Chapter 9.9 "Terminal to function" (TTF) programming principle. Digital output function can be inverted by Control options, parameter ID1084.

487 DIGITAL OUTPUT 1 ON-DELAY (2.3.1.3)

Use this parameter to set the ON delay for the digital output.

488 DIGITAL OUTPUT 1 OFF-DELAY 6 (2.3.1.4)

Use this parameter to set the OFF delay for the digital output.

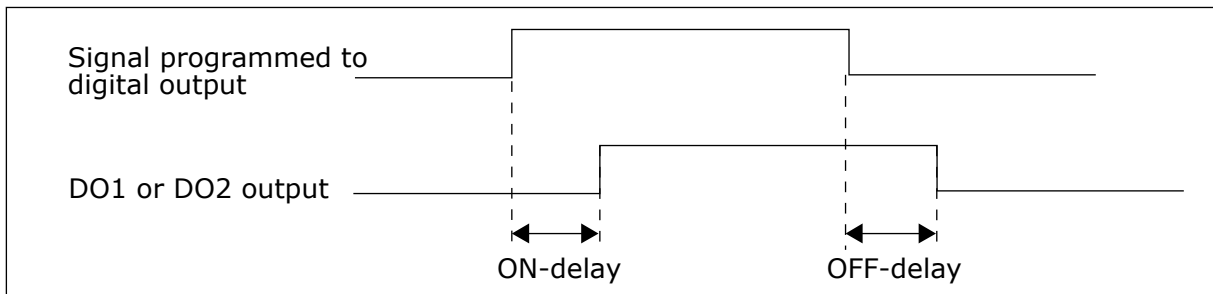

Fig. 65: Digital outputs 1 and 2, on- and off-delays

489 DIGITAL OUTPUT 2 SIGNAL SELECTION * 6 (2.3.2.1)

Use this parameter to connect the digital output signal to the digital output of your choice.

See ID486.

490 DIGITAL OUTPUT 2 FUNCTION 6 (2.3.2.2)

Use this parameter to select the function for the digital output signal.

See ID312.

491 DIGITAL OUTPUT 2 ON-DELAY 6 (2.3.2.3)

Use this parameter to set the ON delay for the digital output.

492 DIGITAL OUTPUT 2 OFF-DELAY 6 (2.3.2.4)

Use this parameter to set the OFF delay for the digital output.

See parameters ID487 and ID488.

493 ADJUST INPUT 6 (2.2.1.4)

Use this parameter to select the signal that adjusts the frequency reference of the motor.

Table 151: Selections for parameter ID493

Selection number	Selection name	Description
0	Not used	
1	Analogue input 1	
2	Analogue input 2	
3	Analogue input 3	
4	Analogue input 4	
5	Signal from fieldbus (FBProcessDataIN)	See Chapter 9.7 <i>Fieldbus control parameters (IDs 850 to 859)</i> and parameter group G2.9

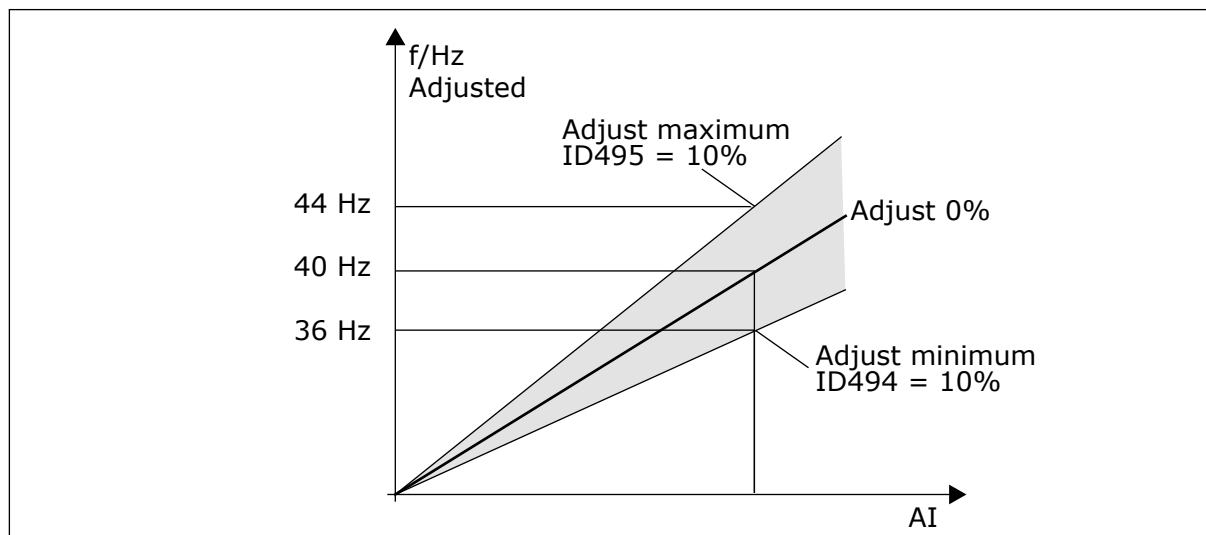

Fig. 66: An example of adjust input

494 ADJUST MINIMUM 6 (2.2.1.5)

Use this parameter to set additional scaling to the adjusted frequency reference.

495 ADJUST MAXIMUM 6 (2.2.1.6)

Use this parameter to set additional scaling to the adjusted frequency reference.

See Fig. 66 An example of adjust input.

**NOTE!**

The adjustment is made to the basic reference signal.

496 PARAMETER SET 1/SET 2 SELECTION * 6 (2.2.7.21)

Use this parameter to set the digital input that selects the parameter set to be used.

This parameter defines the digital input, which can be used to select between Parameter Set 1 and Set 2. The input for this function can be selected from any slot. The procedure of selecting between the sets is explained in the product's User Manual.

Digital input = FALSE:

- Set 1 is loaded as the active set

Digital input = TRUE:

- Set 2 is loaded as the active set

**NOTE!**

The parameter values are stored only when selecting P6.3.1 Parameter sets Store Set 1 or Store Set 2 in System menu or from NCDrive: Drive > Parameter Sets.

498 START PULSE MEMORY 3 (2.2.24)

Use this parameter to select if the RUN status is copied when the control place is changed between A and B.

Table 152: Selections for parameter ID498

Selection number	Selection name	Description
0	The RUN status is not copied	
1	The RUN status is copied	

In order for this parameter to have effect, parameters ID300 and ID363 must have been set the value 3.

500 ACCELERATION/DECELARATION RAMP 1 SHAPE 234567 (2.4.1)

Use this parameter to make the start and the end of the acceleration and deceleration ramps smoother.

501 ACCELERATION/DECELERATION RAMP 2 SHAPE 234567 (2.4.2)

Use this parameter to make the start and the end of the acceleration and deceleration ramps smoother.

If you set the value to 0.0%, you get a linear ramp shape. The acceleration and deceleration act immediately to the changes in the reference signal.

When you set the value between 1.0% and 100.0%, you get an S-shaped acceleration or deceleration ramp. Use this function to reduce mechanical erosion of the parts and current spikes when the reference changes. You can modify the acceleration time with parameters ID103/ID104 (ID502/ID503).

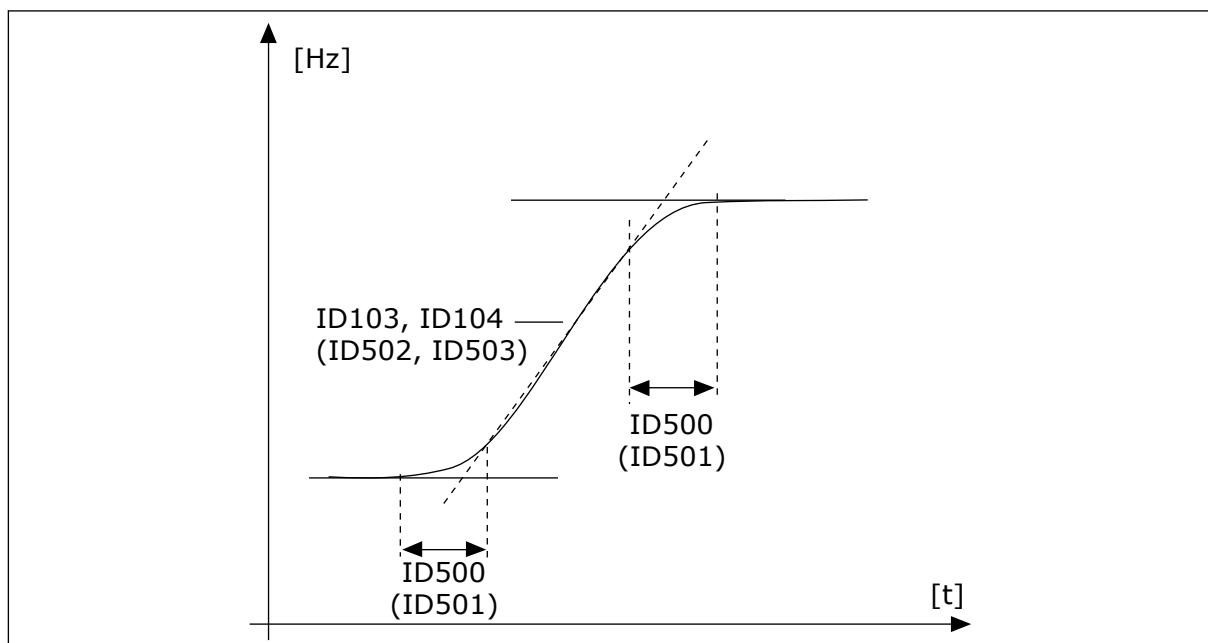

Fig. 67: Acceleration/Deceleration (S-shaped)

502 ACCELERATION TIME 2 234567 (2.4.3)

Use this parameter to set the time that is necessary for the output frequency to increase from zero frequency to maximum frequency.

503 DECELERATION TIME 2 234567 (2.4.4)

Use this parameter to set the time that is necessary for the output frequency to decrease from maximum frequency to zero frequency.

These values correspond to the time required for the output frequency to accelerate from the zero frequency to the set maximum frequency (parameter ID102). These parameters give the possibility to set two different acceleration/ deceleration time sets for one application. The active set can be selected with the programmable signal DIN3 (parameter ID301).

504 BRAKE CHOPPER 234567 (2.4.5)

Use this parameter to select the brake chopper mode.

Table 153: Selections for parameter ID504

Selection number	Selection name	Description
0	No brake chopper used	
1	Brake chopper in use and tested when running.	Can be tested also in READY state.
2	External brake chopper (no testing)	
3	Used and tested in READY state and when running	
4	Used when running (no testing)	

When the AC drive is decelerating the motor, the inertia of the motor and the load are fed into an external brake resistor. This enables the AC drive to decelerate the load with a torque equal to that of acceleration (provided that the correct brake resistor has been selected).

The brake chopper test mode generates a pulse to the resistor every second. If the pulse feedback is wrong (resistor or chopper is missing) fault F12 is generated.

See separate Brake resistor installation manual.

505 START FUNCTION (2.4.6)

Use this parameter to select the type of the start function.

Table 154: Selections for parameter ID505

Selection number	Selection name	Description
0	Ramp	The AC drive starts from 0 Hz and accelerates to the set reference frequency within the set acceleration time. (Load inertia or starting friction may cause prolonged acceleration times).
1	Flying start	The AC drive is able to start into a running motor by applying small current pulses to motor and searching for the frequency corresponding to the speed the motor is running at. Searching starts from the maximum frequency towards the actual frequency until the correct value is detected. Thereafter, the output frequency will be increased/ decreased to the set reference value according to the set acceleration/ deceleration parameters. Use this mode if the motor is coasting when the start command is given. With the flying start it is possible to start the motor from actual speed without forcing the speed to zero before ramping to reference.
2	Conditional flying start	With this mode it is possible to disconnect and connect the motor from the AC drive even when the Start command is active. On re-connecting the motor, the drive will operate as described in selection 1.

506 STOP FUNCTION (2.4.7)

Use this parameter to select the type of the stop function.

Table 155: Selections for parameter ID506

Selection number	Selection name	Description
0	Coasting	The motor coasts to a halt without any control from the AC drive, after the Stop command.
1	Ramp:	After the Stop command, the speed of the motor is decelerated according to the set deceleration parameters to zero speed. If the regenerated energy is high it may be necessary to use an external braking resistor to stop within the set deceleration time.
2	Normal stop: Ramp/ Run Enable stop: coasting	After the Stop command, the speed of the motor is decelerated according to the set deceleration parameters. However, when Run Enable is selected, the motor coasts to a halt without any control from the AC drive.
3	Normal stop: Coasting/ Run Enable stop: ramping	The motor coasts to a halt without any control from the AC drive. However, when Run Enable signal is selected, the speed of the motor is decelerated according to the set deceleration parameters. If the regenerated energy is high it may be necessary to use an external braking resistor for faster deceleration.

507 DC-BRAKING CURRENT 234567 (2.4.8)

Use this parameter to set the current that is fed into the motor during DC braking.

DC-brake in stop state will only use a tenth of this parameter value.

This parameter is used together with parameter ID516 to decrease the time before the motor is able to produce maximum torque at start-up.

508 DC-BRAKING TIME AT STOP 234567 (2.4.9)

Use this parameter to set the braking is ON or OFF and to give the braking time when the motor stops.

The function of the DC-brake depends on the stop function, parameter ID506.

Table 156: Selections for parameter ID508

Selection number	Selection name	Description
0	DC-brake is not used	
>0	DC-brake is in use and its function depends on the Stop function, (parameter ID506). The DC-braking time is determined with this parameter.	

PARAMETER ID506 = 0; STOP FUNCTION = COASTING:

After the stop command, the motor coasts to a stop without control of the AC drive.

With DC-injection, the motor can be electrically stopped in the shortest possible time, without using an optional external braking resistor.

The braking time is scaled according to the frequency when the DC-braking starts. If the frequency is \geq the nominal frequency of the motor, the set value of parameter ID508 determines the braking time. When the frequency is $\leq 10\%$ of the nominal, the braking time is 10% of the set value of parameter ID508.

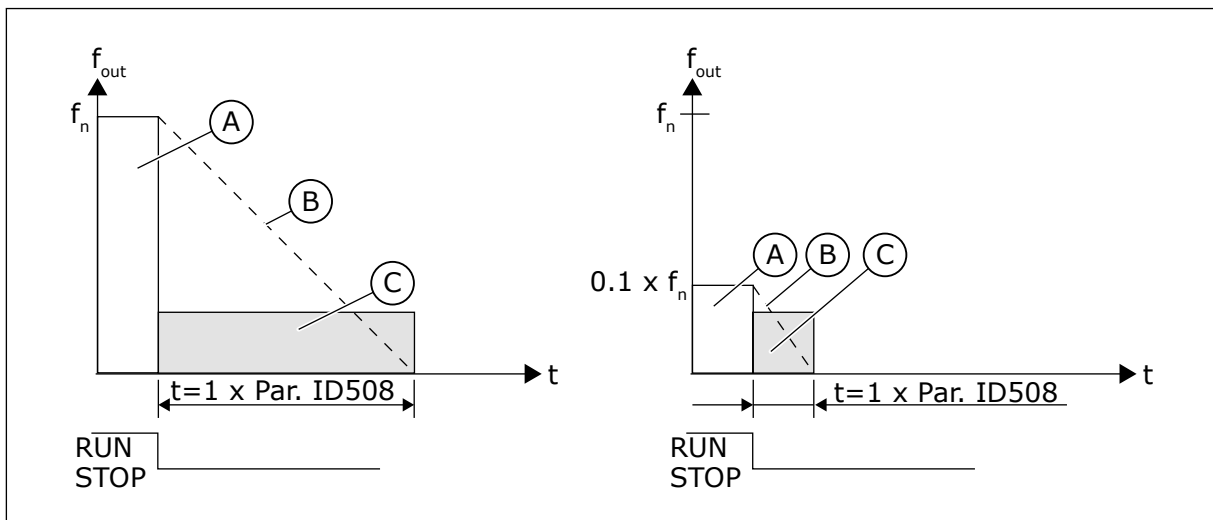

Fig. 68: DC-braking time when Stop mode = Coasting

- A. Output frequency
- B. Motor speed
- C. DC-braking ON

PARAMETER ID506 = 1; STOP FUNCTION = RAMP:

After the Stop command, the speed of the motor is reduced according to the set deceleration parameters, as fast as possible, to the speed defined with parameter ID515, where the DC-braking starts.

The braking time is defined with parameter ID508. If high inertia exists, it is recommended to use an external braking resistor for faster deceleration.

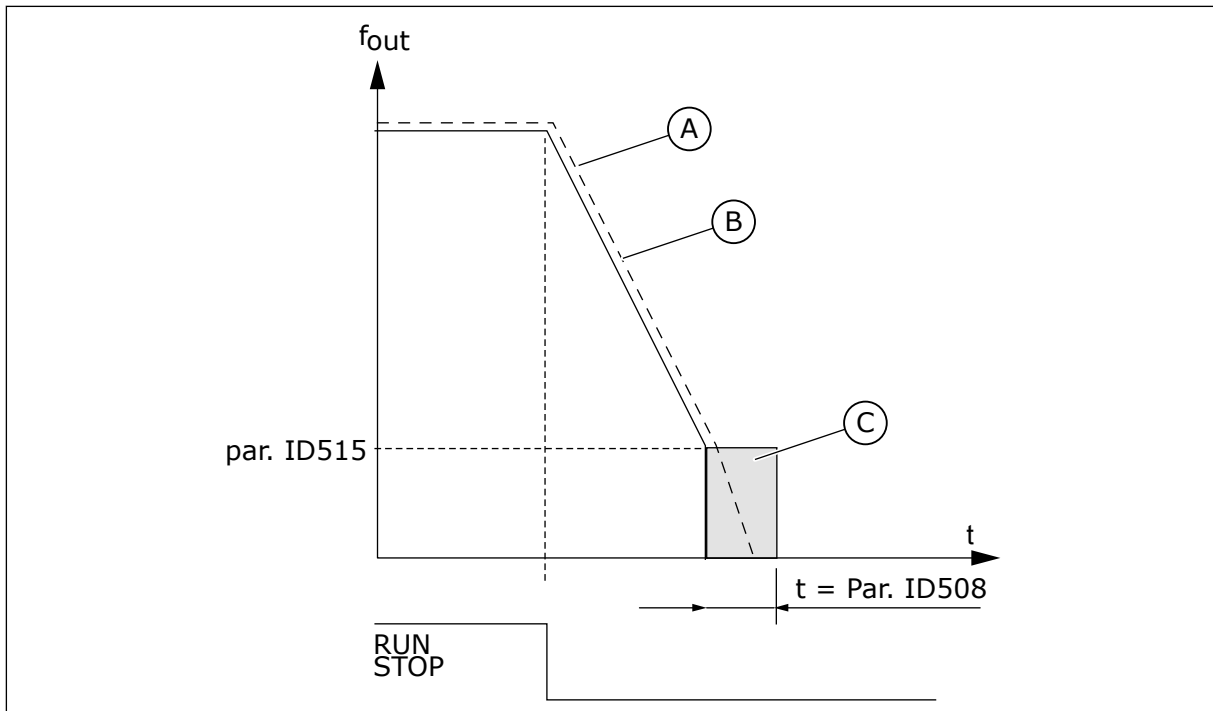

Fig. 69: DC-braking time when Stop mode = Ramp

- A. Motor speed
 B. Output frequency
 C. DC-braking

509 PROHIBIT FREQUENCY AREA 1; LOW LIMIT 23457 (2.5.1)

Use this parameter to prevent the drive operating on the prohibited frequencies.

510 PROHIBIT FREQUENCY AREA 1; HIGH LIMIT 23457 (2.5.2)

Use this parameter to prevent the drive operating on the prohibited frequencies.

511 PROHIBIT FREQUENCY AREA 2; LOW LIMIT 3457 (2.5.3)

Use this parameter to prevent the drive operating on the prohibited frequencies.

512 PROHIBIT FREQUENCY AREA 2; HIGH LIMIT 3457 (2.5.4)

Use this parameter to prevent the drive operating on the prohibited frequencies.

513 PROHIBIT FREQUENCY AREA 3; LOW LIMIT 3457 (2.5.5)

Use this parameter to prevent the drive operating on the prohibited frequencies.

514 PROHIBIT FREQUENCY AREA 3; HIGH LIMIT 3457 (2.5.6)

Use this parameter to prevent the drive operating on the prohibited frequencies.

In some systems it may be necessary to avoid certain frequencies because of mechanical resonance problems. With these parameters it is possible to set limits for the "skip frequency" region.

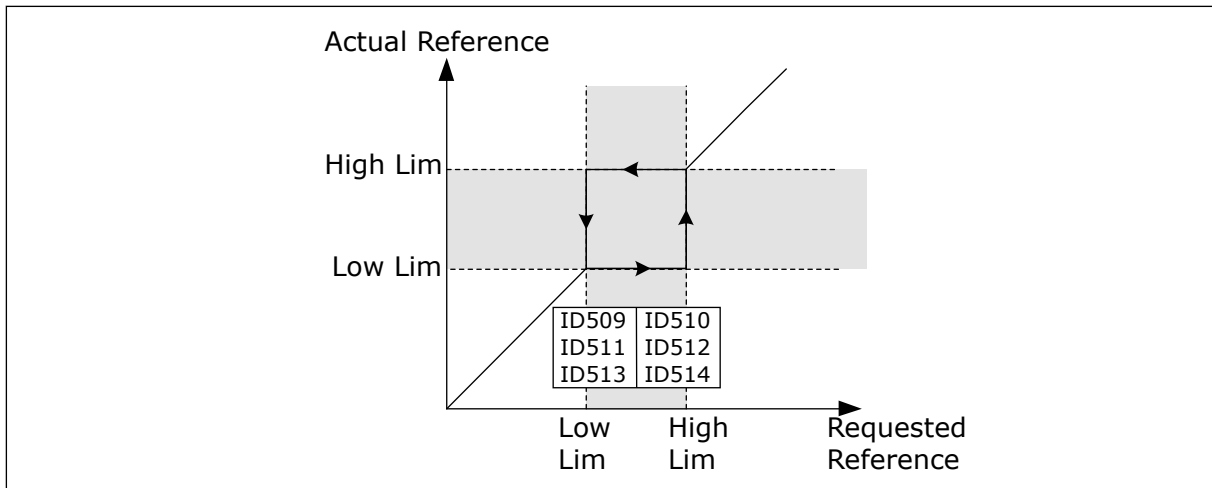

Fig. 70: Example of prohibit frequency area setting

515 DC BRAKING FREQUENCY AT STOP 234567 (2.4.10)

Use this parameter to set the output frequency at which the DC braking starts.

See Fig. 70 Example of prohibit frequency area setting.

516 DC-BRAKING TIME AT START 234567 (2.4.11)

Use this parameter to set the time during which the DC current is fed to the motor before the acceleration starts.

DC brake current is used at start in order to premagnetize the motor before running. This will improve the torque performance at start. Varying between 100 ms to 3 s, the time needed depends on motor size. A bigger motor requires a longer time. See parameter ID507.



NOTE!

When Flying Start (see parameter ID505) is used as start function DC braking at start is disabled.

518 ACCELERATION/DECELERATION RAMP SPEED SCALING RATIO BETWEEN PROHIBIT FREQUENCY LIMITS 23457 (2.5.3, 2.5.7)

Use this parameter to set the multiplier of the selected ramp times when the output frequency of the drive is between the prohibited frequency limits.

Defines the acceleration/deceleration time when the output frequency is between the selected prohibit frequency range limits (parameters ID509 to ID514). The ramping speed (selected acceleration/ deceleration time 1 or 2) is multiplied with this factor. E.g. value 0.1 makes the acceleration time 10 times shorter than outside the prohibit frequency range limits.

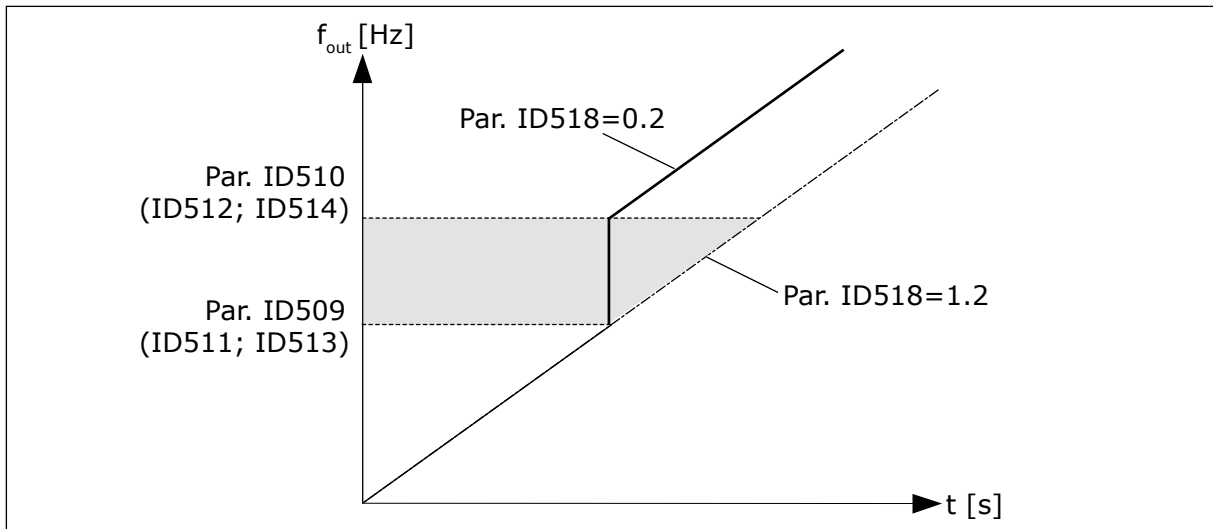

Fig. 71: Ramp speed scaling between prohibit frequencies

519 FLUX BRAKING CURRENT 234567 (2.4.13)

Use this parameter to set the current level for the flux braking.

The value setting range depends on the used application.

520 FLUX BRAKE 234567 (2.4.12)

Use this parameter to enable the Flux Braking function.

As an alternative to DC braking, you can use flux braking. Flux braking increases the braking capacity in conditions where additional brake resistors are not necessary.

When braking is necessary, the system decreases the frequency and increases the flux in the motor. This increases the capacity of the motor to brake. The motor speed is controlled during braking.

You can enable and disable Flux Braking.

Table 157: Selections for parameter ID520

Selection number	Selection name	Description
0	Flux braking OFF	
1	Flux braking ON	



CAUTION!

Use the braking only intermittently. Flux braking converts energy into heat and can cause damage to the motor.

521 MOTOR CONTROL MODE 26 (2.6.12)

Use this parameter to set the AC drive control mode.

Which mode is used is determined with parameter ID164.

For the selections, see parameter ID600.

**NOTE!**

Motor control mode can not be changed from Open Loop to Closed Loop and vice versa while the drive is in RUN state.

530 INCHING REFERENCE 1 6 (2.2.7.27)

Use this parameter to select the digital input signal that activates the inching reference.

531 INCHING REFERENCE 2 6 (2.2.7.28)

Use this parameter to select the digital input signal that activates the inching reference.

**NOTE!**

The inputs also start the drive if activated and if there is no Run Request command from anywhere else.

Negative reference is used for reverse direction (see parameters ID1239 and ID1240).

The parameter is available for NXP drives only.

532 ENABLE INCHING 6 (2.2.7.26)

Use this parameter to select the digital input signal that activates the inching function.

Inching is a combination of a start command and preset speeds (ID1239 and ID1240) with a ramp time (ID533).

If you use the inching function the input value must be TRUE set by a digital signal or by setting the value of the parameter to 0.2. The parameter is available for NXP drives only.

550 TO 557 FIELDBUS DATA IN SELECTIONS 9 TO 16 6 (2.9.27 TO 2.9.34)

Use this parameter to select a parameter or monitoring value to be controlled from the fieldbus.

These parameters are visible only if the option board installed to AC drive supports 16 Process data items.

Enter the ID number of the item you wish to control for the value of these parameters. See *Table 45 Monitoring values, NXP drives*.

558 TO 565 FIELDBUS DATA OUT SELECTIONS 9 TO 16 6 (2.9.11 TO 2.9.18)

Use this parameter to select the data that is sent to the fieldbus with the ID number of the parameter or monitor value.

These parameters are visible only if the option board installed to AC drive supports 16 Process data items.

See also Chapter *Table 45 Monitoring values, NXP drives* for more monitoring values.

600 MOTOR CONTROL MODE 234567 (2.6.1)

Use this parameter to set the AC drive control mode.

Table 158: Selections for motor control mode in different applications

Application	2	3	4	5	6	7
Sel						
0	NXS/P	NXS/P	NXS/P	NXS/P	NXS/P	NXS
1	NXS/P	NXS/P	NXS/P	NXS/P	NXS/P	NXS
2	Not used	Not used	Not used	Not used	NXS/P	NA
3	NXP	NXP	NXP	NXP	NXP	NA
4	NA	NA	NA	NA	NXP	NA

Table 159: Selection for ID600 Motor control mode

Selection number	Selection name	Description
0	Frequency control	Drive frequency reference is set to output frequency without slip compensation. Motor actual speed is finally defined by motor load.
1	Speed control	Drive frequency reference is set to motor speed reference. The motor speed is remains the same regardless of motor load. Slip is compensated.
2	Torque control	Speed reference is used as maximum speed limit and the motor produces torque within speed limit to achieve torque reference.
3	Speed ctrl (closed loop)	Drive frequency reference is set to motor speed reference. The motor speed remains the same regardless of motor load. In Closed Loop control mode, speed feedback signal is used to achieve optimum speed accuracy.
4	Torque ctrl (closed loop)	Speed reference is used as the maximum speed limit that depends on the torque speed limit CL (ID1278) and motor produces torque within speed limit to achieve torque reference. In Closed Loop control mode, speed feedback signal is used to achieve optimum torque accuracy.

601 SWITCHING FREQUENCY 234567 (2.6.9)

Use this parameter to set the switching frequency of the AC drive.

If you increase the switching frequency, the capacity of the AC drive reduces. To reduce capacitive currents in the motor cable, when the cable is long, we recommend that you use a low switching frequency. To reduce the motor noise, use a high switching frequency.

The range of this parameter depends on the size of the AC drive:

Table 160: Size-dependent switching frequencies

Type	Min. [kHz]	Max. [kHz]	Default [kHz]
0003—0061 NX_2	1.0	16.0	10.0
0075—0300 NX_2	1.0	10.0	3.6
0003—0061 NX_5	1.0	16.0	10.0
0072—0520 NX_5	1.0	6.0	3.6
0004—0590 NX_6	1.0	6.0	1.5



NOTE!

The actual switching frequency might be reduced down to 1.5kHz by thermal management functions. This has to be considered when using sine wave filters or other output filters with a low resonance frequency. See parameters ID1084 and ID655.

602 FIELD WEAKENING POINT 234567 (2.6.4)

Use this parameter to set the output frequency at which the output voltage reaches the field weakening point voltage.

603 VOLTAGE AT FIELD WEAKENING POINT 234567 (2.6.5)

Use this parameter to set the voltage at the field weakening point as a percentage of the motor nominal voltage.

Above the frequency at the field weakening point, the output voltage stays at the set maximum value. Below the frequency at the field weakening point, the U/f curve parameters control the output voltage. See the parameters ID109, ID108, ID604 and ID605.

When you set the parameters ID110 and ID111 (nominal voltage and nominal frequency of the motor), the parameters ID602 and ID603 automatically receive related values. To have different values for the field weakening point and the maximum output voltage, change these parameters only after you set the parameters P3.1.1.1 and P3.1.1.2.

604 U/F CURVE, MIDDLE POINT FREQUENCY 234567 (2.6.6)

Use this parameter to set the middle point frequency of the U/f curve.

If the value of ID108 is programmable, this parameter gives the middle point frequency of the curve. See Fig. 24 *Linear and squared change of the motor voltage* and parameter ID605.

605 U/F CURVE, MIDDLE POINT VOLTAGE 234567 (2.6.7)

Use this parameter to set the middle point voltage of the U/f curve.

If the value of ID108 is programmable, this parameter gives the middle point voltage of the curve. See Chapter *108 U/F ratio selection 234567 (2.6.3)*.

606 OUTPUT VOLTAGE AT ZERO FREQUENCY 234567 (2.6.8)

Use this parameter to set the zero frequency voltage of the U/f curve.

The default value is different for different unit sizes.



NOTE!

If the value of parameter ID108 is changed this parameter is set to zero. See *Fig. 25 The programmable U/f curve*.

607 OVERVOLTAGE CONTROLLER 234567 (2.6.10)

Use this parameter to set the overvoltage controller out of operation.

When you enable ID607 or ID608, the controllers start to monitor the changes in the supply voltage. The controllers change the output frequency if it becomes too high or too low.

To stop the operation of the undervoltage and the overvoltage controllers, disable these 2 parameters. This is useful if the supply voltage changes more than -15% to +10%, and if the application does not tolerate the operation of the controllers.

Table 161: Selections for parameter ID607

Selection number	Selection name	Description
0	Controller switched off	
1	Controller switched on (no ramping)	Minor adjustments of OP frequency are made
2	Controller switched on (with ramping)	Controller adjusts OP freq. up to max.freq.

When a value other than 0 is selected also the Closed Loop overvoltage controller becomes active (in Multi-Purpose Control application).

608 UNDERVOLTAGE CONTROLLER 234567 (2.6.11)

Use this parameter to set the undervoltage controller out of operation.

See parameter ID607.

Undervoltage controller is PI-type controller for which the input is the difference of undervoltage reference value and the dc-link voltage actual value.

The controller output is additive to the frequency reference, that is, the undervoltage controller tries to decrease the motor speed in case of undervoltage. As an effect, the motoring power is reduced and additional generating power is obtained from the deceleration of the system inertia. UV-controller is activated when the dc-link voltage drops below the undervoltage reference voltage.

**NOTE!**

Over-/undervoltage trips may occur when controllers are switched out of operation.

Table 162: Selections for parameter ID608

Selection number	Selection name	Description
0	Controller switched off	Both open and closed loop overvoltage controllers are off.
1	Controller switched on (no ramping)	Both open and closed loop overvoltage controllers are activated. If power is restored when the AC drive is at undervoltage, the controller output frequency regains the reference value.
2	Controller switched on (with ramping)	Both open and closed loop controllers are activated. If power is restored after the undervoltage controller has been active, the AC drive ramps to zero speed using ramp time 2 and generates an undervoltage fault (F9) with subcode S3.

When a value other than 0 is selected also the Closed Loop overvoltage controller becomes active (in Multi-Purpose Control application).

609 TORQUE LIMIT 6 (2.10.1)

Use this parameter to set the torque limit control.

With this parameter you can set the torque limit control between 0.0 – 300.0 %.

In the Multi-Purpose Control application, the torque limit is selected between the minimum of this parameter and the motoring and generating torque limits ID1287 and ID1288.

610 TORQUE LIMIT CONTROL P-GAIN 6 (2.10.2)

Use this parameter to set the P-gain of the torque limit controller.

This parameter determines the P-gain of the torque limit controller. It is used in Open Loop control mode only.

611 TORQUE LIMIT CONTROL I-GAIN 6 (2.10.3)

Use this parameter to set the I-gain of the torque limit controller.

This parameter determines the I-gain of the torque limit controller. It is used in Open Loop control mode only.

612 CL: MAGNETIZING CURRENT 6 (2.6.23.1)

Use this parameter to set the magnetising current of the motor.

The magnetising current identifies the values of the U/f parameters if they are given before the identification run. If the value is set to 0, the magnetising current is calculated internally.

In NXP, the values of the U/f parameters are identified according to the magnetizing current if given before identification. See Chapter 9.8 *Closed loop parameters (IDs 612 to 621)*.

613 CL: SPEED CONTROL P GAIN 6 (2.6.23.2)

Use this parameter to set gain for the speed controller as a percentage per Hz.

Gain value 100% means that nominal torque reference is produced at the speed controller output for a frequency error of 1Hz. See Chapter 9.8 *Closed loop parameters (IDs 612 to 621)*.

614 CL: SPEED CONTROL I TIME 6 (2.6.23.3)

Use this parameter to set the integral time constant for the speed controller.

See Chapter 9.8 *Closed loop parameters (IDs 612 to 621)*.

$$\text{SpeedControl Output}(k) = \text{SPC OUT}(k-1) + \text{SPC Kp} * [\text{Speed Error}(k) - \text{Speed Error}(k-1)] + \text{Ki} * \text{Speed error}(k)$$

where $\text{Ki} = \text{SPC Kp} * \text{Ts} / \text{SPC Ti}$.

615 CL: ZERO SPEED TIME AT START 6 (2.6.23.9)

Use this parameter to set the time the AC drive stays at zero speed after the start command.

The speed will be released to follow the set frequency/ speed reference after this time has elapsed from the instant where the command is given. See Chapter 9.8 *Closed loop parameters (IDs 612 to 621)*.

616 CL: ZERO SPEED TIME AT STOP 6 (2.6.23.10)

Use this parameter to set the time the AC drive stays at zero speed after the stop command.

This parameter has no effect if the selected stop function (ID506) is Coasting. The zero speed time starts when the ramp time is expected to reach zero speed. See Chapter 9.8 *Closed loop parameters (IDs 612 to 621)*.

617 CL: CURRENT CONTROL P GAIN 6 (2.6.23.17)

Use this parameter to adjust the P-gain of the current controller.

This controller is active only in closed loop control mode. The controller generates the voltage vector reference to the modulator. See Chapter 9.8 *Closed loop parameters (IDs 612 to 621)*.

618 CL: ENCODER FILTER TIME 6 (2.6.23.15)

Use this parameter to set the filtering time for the speed measurement.

The parameter can be used to eliminate encoder signal noise. Too high a filter time reduces speed control stability. See Chapter 9.8 *Closed loop parameters (IDs 612 to 621)*.

619 CL: SLIP ADJUST 6 (2.6.23.6)

Use this parameter to adjust the voltage of the motor when the motor is loaded.

The motor name plate speed is used to calculate the nominal slip. This value is used to adjust the voltage of motor when loaded. The name plate speed is sometimes a little inaccurate and this parameter can therefore be used to trim the slip. Reducing the slip adjust value increases the motor voltage when the motor is loaded. Value 100% corresponds to nominal slip at nominal load. See Chapter 9.8 *Closed loop parameters (IDs 612 to 621)*.

620 LOAD DROOPING 23456 (2.6.12, 2.6.15)

Use this parameter to enable the Load Drooping function.

The Load drooping function enables a speed drop. This parameter sets the drooping in percentage of the nominal torque of the motor.

You can use this function when a balanced load is necessary for mechanically connected motors.

If the motor has a nominal frequency of 50 Hz, the motor is loaded with the nominal load (100% of the torque), and Load Drooping is set to 10%, the output frequency is let to decrease 5 Hz from the frequency reference.

621 CL: STARTUP TORQUE 6 (2.6.23.11)

Use this parameter to select the startup torque.

Torque Memory is used in crane applications. Startup Torque FWD/REV can be used in other applications to help the speed controller. See Chapter 9.8 *Closed loop parameters (IDs 612 to 621)*.

Table 163: Selections for parameter ID621

Selection number	Selection name	Description
0	Not Used	
1	TorqMemory	Motor will be started at the same torque as it was stopped at
2	Torque Ref	Torque reference is used at start for the startup torque
3	Torque forward/Torque reverse	See ID633 and 634

626 CL: ACCELERATION COMPENSATION 6 (2.6.23.5)

Use this parameter to set the inertia compensation to make the speed response during acceleration and deceleration more accurate.

The time is defined as acceleration time to nominal speed with nominal torque. This feature is used when the inertia of the system is known to achieve the best speed accuracy at alternating references.

$$AccelCompensationTC = J \cdot \frac{2\pi \cdot f_{nom}}{T_{nom}} = J \cdot \frac{(2\pi \cdot f_{nom})^2}{P_{nom}}$$

J = System inertia (kg*m²)

f_{nom} = Motor nominal frequency (Hz)

T^{nom} = Motor nominal torque

P^{nom} = Motor nominal power (kW)

627 CL: MAGNETIZING CURRENT AT START 6 (2.6.23.7)

Use this parameter to set the DC current that is fed into the motor at the start.

Defines the current that is applied to motor when the start command is given (in Closed Loop control mode). At start this parameter is used together with parameter ID628 to decrease the time before the motor is able to produce maximum torque.

628 CL: MAGNETIZING TIME AT START 6 (2.6.23.8)

Use this parameter to set the time during which the DC current is fed to the motor before the acceleration starts.

Defines the time for how long the magnetization current (ID627) is applied to the motor at start. The magnetizing current at start is used in order to premagnetize the motor before running. This will improve the torque performance at start. The time needed depends on the size of the motor. The parameter value varies from 100 ms to 3 seconds. The bigger the motor the more time is needed.

631 IDENTIFICATION 23456 (2.6.13,2.6.16)

Use this parameter to find the parameter values that are optimal for the operation of the drive.

The identification run calculates or measures the motor parameters that are necessary for a good control of the motor and speed.

The identification run helps you to adjust the motor-specific and the drive-specific parameters. It is a tool for the commissioning and the servicing of the drive. The goal is to find the parameter values that are optimal for the operation of the drive.



NOTE!

Before you do the identification run, you have to set the motor nameplate parameters.

ID110Nominal voltage of the motor (P2.1.6)

ID111Nominal frequency of the motor (P2.1.7)

ID112Nominal speed of the motor (P2.1.8)

ID113Nominal current of the motor (P2.1.9)

ID120Motor cos phi (P2.1.10)

Table 164: Selections for parameter ID631

Selection number	Selection name	Description
0	No action	No identification requested.
1	Identification without motor run	The drive is run without speed to identify the motor parameters. The motor is supplied with current and voltage but with zero frequency. U/f ratio is identified.
2	Identification with motor run (NXP only)	The drive is run with speed to identify the motor parameters. U/f ratio and magnetization current are identified. NOTE! This identification run must be performed with no load on the motor shaft for accurate results.
3	Encoder identification run	Identifies the shaft zero position when using PMS motor with absolute encoder.
4	(Reserved)	
5	Identification failed	This value is stored if identification fails.

To activate the Identification function, set this parameter and give a start command. You have to give the start command in 20 s. If there is no start command in that time, the identification run does not start. The parameter is reset to the default value and an identification alarm shows.

To stop the identification run before it is completed, give a stop command. This resets the parameter to the default value. If the identification run is not completed, an identification alarm shows.

During Identification Run, the brake control is disabled (see Chapter 9.3 *External brake control with additional limits (IDs 315, 316, 346 to 349, 352, 353)*).

**NOTE!**

Rising edge required to start after identification.

633 CL: START-UP TORQUE, FORWARD 23456 (2.6.23.12)

Use this parameter to set the start-up torque for forward direction when StartUp Torque is in use.

Sets the start-up torque for forward direction if selected with parameter ID621.

634 CL: START-UP TORQUE, REVERSE 23456 (2.6.23.13)

Use this parameter to set the start-up torque for reverse direction when StartUp Torque is in use.

Sets the start-up torque for reverse direction if selected with parameter ID621.

636 MINIMUM FREQUENCY FOR OPEN LOOP TORQUE CONTROL 6 (2.10.7)

Use this parameter to set the output frequency limit below which the drive operates in the frequency control mode.

Because of the nominal slip of the motor, the internal torque calculation is inaccurate at low speeds where it is recommended to use the frequency control mode.

637 SPEED CONTROLLER P GAIN, OPEN LOOP 6 (2.6.13)

Use this parameter to set the P gain for the speed controller.

638 SPEED CONTROLLER I GAIN, OPEN LOOP 6 (2.6.14)

Use this parameter to set the I gain for the speed controller.

639 TORQUE CONTROLLER P GAIN 6 (2.10.8)

Use this parameter to set the P gain for the torque controller in the open loop control mode.

640 TORQUE CONTROLLER I GAIN 6 (2.10.9)

Use this parameter to set the I gain for the torque controller in the open loop control mode.

641 TORQUE REFERENCE SELECTION 6 (2.10.3)

Use this parameter to select the torque reference.

See Chapter 9.7 *Fieldbus control parameters (IDs 850 to 859)*.

Table 165: Selections for parameter ID641

Selection number	Selection name	Description
0	Not used	
1	Analogue input 1	
2	Analogue input 2	
3	Analogue input 3	
4	Analogue input 4	
5	Analogue input 1 (joystick)	
6	Analogue input 2 (joystick)	
7	From keypad, parameter R3.5	
8	Fieldbus torque reference	See Chapter 9.7 <i>Fieldbus control parameters (IDs 850 to 859)</i> .

642 TORQUE REFERENCE SCALING, MAXIMUM VALUE 6 (2.10.4)

Use this parameter to set the maximum torque reference of the positive and negative values.

643 TORQUE REFERENCE SCALING, MINIMUM VALUE 6 (2.10.5)

Use this parameter to set the minimum torque reference of the positive and negative values. Scale the custom minimum and maximum levels for analogue inputs within -300.0...300.0%.

644 TORQUE SPEED LIMIT, OPEN LOOP 6 (2.10.6)

Use this parameter to select the maximum frequency for the torque control.

Table 166: Selections for parameter ID644

Selection number	Selection name	Description
0	Maximum frequency	
1	Selected frequency reference	
2	Preset speed 7	

NXP drives have more selections for this parameter in Closed Loop control mode. See ID1278.

645 NEGATIVE TORQUE LIMIT 6 (2.6.23.21)

Use this parameter to set the torque limit for negative direction.

646 POSITIVE TORQUE LIMIT 6 (2.6.23.22)

Use this parameter to set the torque limit for positive direction.

649 PMS MOTOR ZERO SHAFT POSITION 6 (2.6.24.4)

Use this parameter to set the zero shaft position.

Updated during encoder identification run with an absolute encoder.

650 MOTOR TYPE 6 (2.6.24.1)

Use this parameter to set the type of motor in your process.

Table 167: Selections for ID650

Selection number	Selection name	Description
0	Induction motor	
1	Permanent magnet synchronous motor	

651 FLUX CURRENT KP 6 (P2.6.24.8)

Use this parameter to set the gain for the flux current controller.

Defines the gain for the flux current controller when using a PMS motor. Depending on the motor construction and the ramp rate that is used to go to the field weakening area, high gain may be needed so that the output voltage does not reach maximum limit and prevent proper motor control. Too high gain may lead to unstable control. Integration time is more significant in this case for control.

652 FLUX CURRENT TIME 6 (P2.6.24.9)

Use this parameter to set the integration time for the flux current controller.

Defines the integration time for the flux current controller when using a PMS motor. Depending on motor construction and the ramp rate that is used to go to field weakening area, short integration times may be needed so that the output voltage do not reach maximum limit and prevent proper motor control. Too fast integration time may also lead to unstable control.

655 MODULATION LIMIT 6 (2.6.23.34)

Use this parameter to control how the AC drive modulates the output voltage.

Reducing this value limits the maximum output voltage. If a sinusoidal filter is used set this parameter to 96%.

656 LOAD DROOPING TIME 6 (2.6.18)

Use this parameter to set the drooping time of the motor.

Use load drooping to get a dynamic speed drooping when the load changes. This parameter gives the time during which the speed is restored 63% of the change.

657 CURRENT CONTROL TIME 6 (P2.6.23.18)

Use this parameter to adjust the integrator time constant of current controller. This value is presented in seconds.

662 MEASURED VOLTAGE DROP 6 (2.6.25.16)

Use this parameter to set the measured voltage drop at stator resistance between two phases with the nominal current of the motor.

The measured voltage drop at stator resistance between two phases with the nominal current of the motor. This parameter is identified during the ID run. Set this value to gain the optimum torque calculation for Open Loop low frequencies.

664 IR: ADD ZERO POINT VOLTAGE 6 (2.6.25.17)

Use this parameter to set the amount of voltage that is fed to the motor at zero speed when the torque boost is used.

665 IR: ADD GENERATOR SCALE 6 (2.6.25.19)

Use this parameter to set the scaling factor for the generating side IR-compensation when the torque boost is used.

667 IR: ADD MOTORING SCALE 6 (2.6.25.20)

Use this parameter to set the scaling factor for the motoring side IR-compensation when the torque boost is used.

668 IU OFFSET 6 (2.6.25.21)

Use this parameter to set the offset value for the phase current measurement.

669 IV OFFSET 6 (2.6.25.22)

Use this parameter to set the offset value for the phase current measurement.

670 IW OFFSET 6 (2.6.25.23)

Use this parameter to set the offset value for the phase current measurement.

Identified during ID run.

673 LS VOLTAGE DROP 6 (P2.6.25.21)

Use this parameter to set the Ls voltage drop between two phases.

Leakage inductance voltage drop with nominal current and frequency of the motor. This parameter defines the Ls voltage drop between two phases. Use identification run to determine the optimum setting.

674 MOTORBEM VOLTAGE 6 (2.6.25.20)

Use this parameter to adjust the motor-induced back voltage.

700 RESPONSE TO THE 4MA REFERENCE FAULT 234567 (2.7.1)

Use this parameter to select the response of the AC drive to a '4mA Input' fault.

Table 168: Selections for parameter ID700

Selection number	Selection name	Description
0	No response	
1	Warning	
2	Warning	The frequency from 10 seconds back is set as reference
3	Warning	The 4mA fault frequency (parameter ID728) is set as reference
4	Fault	Stop mode after fault according to ID506
5	Fault	Stop mode after fault always by coasting

A warning or a fault action and message is generated if the 4-20 mA reference signal is used and the signal falls below 3.0 mA for 5 seconds or below 0.5 mA for 0.5 seconds. The information can also be programmed into digital output DO1 and relay outputs RO1 and RO2.

701 RESPONSE TO EXTERNAL FAULT 234567 (2.7.3)

Use this parameter to select the response of the drive to an 'External Fault'.

Table 169: Selections for parameter ID701

Selection number	Selection name	Description
0	No response	
1	Warning	
2	Fault, stop mode after fault according to ID506	
3	Fault, stop mode after fault always by coasting	

A warning or a fault action and message is generated from the external fault signal in the programmable digital inputs DIN3 or with parameters ID405 and ID406. The information can also be programmed into digital output DO1 and relay outputs RO1 and RO2.

702 OUTPUT PHASE SUPERVISION 234567 (2.7.6)

Use this parameter to select the response of the drive to an 'Output Phase' fault.

Table 170: Selections for parameter ID702

Selection number	Selection name	Description
0	No response	
1	Warning	
2	Fault, stop mode after fault according to ID506	
3	Fault, stop mode after fault always by coasting	

Output phase supervision of the motor ensures that the motor phases have an approximately equal current.

703 EARTH FAULT PROTECTION 234567 (2.7.7)

Use this parameter to select the response of the drive to an 'Earth Fault'.

Table 171: Selections for parameter ID703

Selection number	Selection name	Description
0	No response	
1	Warning	
2	Fault, stop mode after fault according to ID506	
3	Fault, stop mode after fault always by coasting	

Earth fault protection ensures that the sum of the motor phase currents is zero. The overcurrent protection is always working and protects the AC drive from earth faults with high currents.

704 MOTOR THERMAL PROTECTION 234567 (2.7.8)

Use this parameter to select the response of the drive to 'Motor Overtemperature' fault.

Table 172: Selections for parameter ID704

Selection number	Selection name	Description
0	No response	
1	Warning	
2	Fault, stop mode after fault according to ID506	
3	Fault, stop mode after fault always by coasting	

Deactivating the protection, i.e. setting parameter to 0, will reset the thermal stage of the motor to 0%. See Chapter 9.4 *Parameters of motor thermal protection (IDs 704 to 708)*.

Motor overtemperature sensing is required if the parameter is set to 0.

705 MOTOR THERMAL PROTECTION: MOTOR AMBIENT TEMP. FACTOR 234567 (2.7.9)

Use this parameter to set the ambient temperature factor at which you install the motor.

The factor can be set between -100.0%...100.0% where

-100.0 % = 0 °C

0.0 % = 40 °C

100.0 % = 80 °C

See Chapter 9.4 *Parameters of motor thermal protection (IDs 704 to 708)*.

706 MOTOR THERMAL PROTECTION: MOTOR COOLING FACTOR AT ZERO SPEED 234567 (2.7.10)

Use this parameter to set the cooling factor at 0 speed in relation to the point where the motor operates at nominal speed without external cooling.

See Fig. 72 *The motor thermal current IT curve*.

The default value is set for conditions where there is no external fan. If you use an external fan, you can set the value higher than without the fan, for example at 90%.

If you change parameter Motor Nominal Current, this parameter is automatically set to its default value.

Although you change this parameter, it does not have an effect on the maximum output current of the drive. See Chapter 9.4 *Parameters of motor thermal protection (IDs 704 to 708)*.

The corner frequency for the thermal protection is 70% of the value of the parameter Motor Nominal Frequency (ID111).

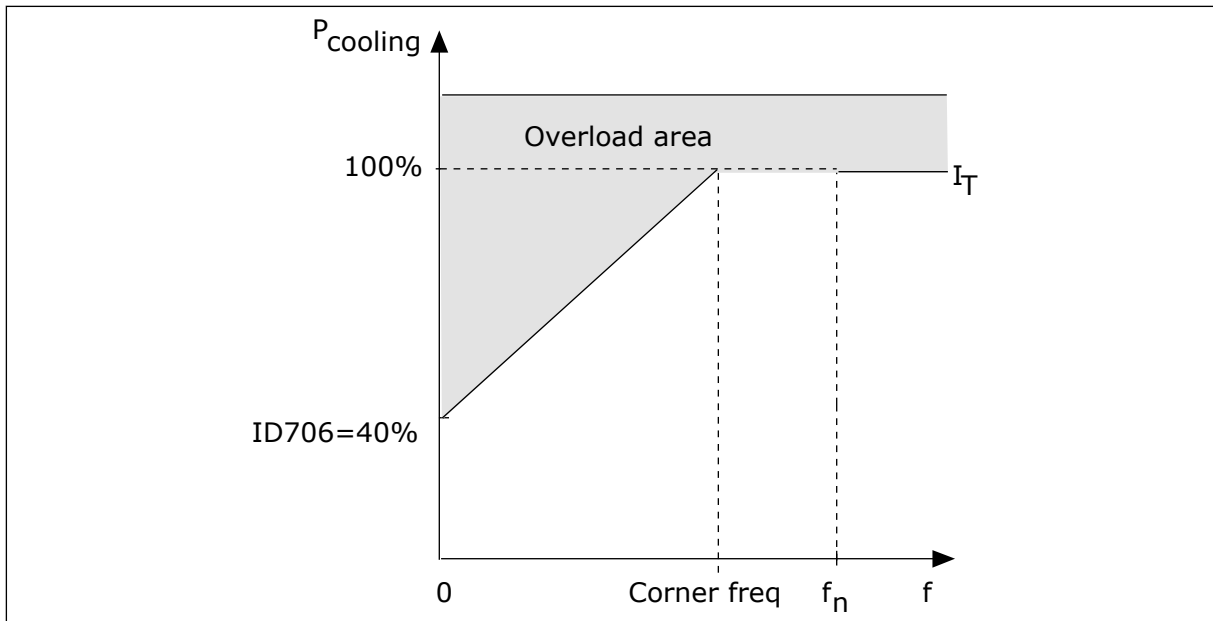

Fig. 72: The motor thermal current I_T curve

707 MOTOR THERMAL PROTECTION: TIME CONSTANT 234567 (2.7.11)

Use this parameter to set the motor thermal time constant.

This time can be set between 1 and 200 minutes.

The time constant is the time during which the calculated warming curve becomes 63% of its target value. The length of the time constant is in relation with the dimension of the motor. The bigger the motor, the longer the time constant.

In different motors, the motor thermal time constant is different. It also changes between different motor manufacturers. The default value of the parameter changes from dimension to dimension.

The t_6 -time is the time in seconds that the motor can safely operate at 6 times the rated current. It is possible that the motor manufacturer gives the data with the motor. If you know the t_6 of the motor, you can set the time constant parameter with its help. Usually, the motor thermal time constant in minutes is $2 \cdot t_6$. When the drive is in the STOP state, the time constant is internally increased to 3 times the set parameter value, because the cooling operates based on convection.

See also Fig. 73 The motor thermal time constant.

708 MOTOR THERMAL PROTECTION: MOTOR DUTY CYCLE 234567 (2.7.12)

Use this parameter to set the factor for the thermal loadability of the motor.

The value can be set to 0%-150%. See Chapter 9.4 Parameters of motor thermal protection (IDs 704 to 708).

For example, if you set the value to 130%, the motor goes to the nominal temperature with 130% of the motor nominal current.

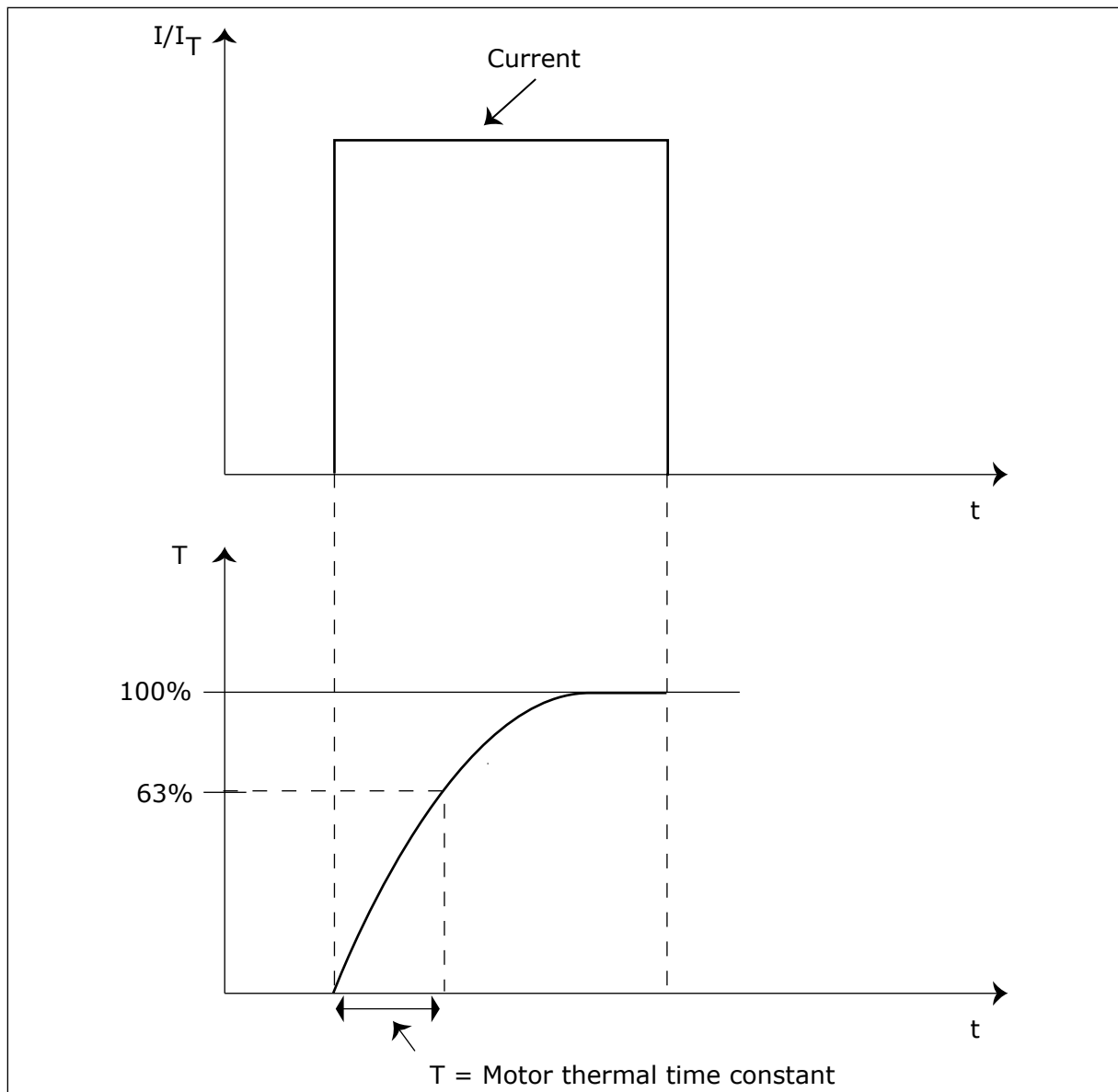

Fig. 73: The motor thermal time constant

709 STALL PROTECTION 234567 (2.7.13)

Use this parameter to select the response of the drive to 'Motor Stall' fault.

Table 173: Selections for parameter ID709

Selection number	Selection name	Description
0	No response	
1	Warning	
2	Fault, stop mode after fault according to ID506	
3	Fault, stop mode after fault always by coasting	

Setting the parameter to 0 will deactivate the protection and reset the stall time counter. See Chapter 9.5 *Parameters of stall protection (IDs 709 to 712)*.

710 STALL CURRENT LIMIT 234567 (2.7.14)

Use this parameter to set the limit above which the current of the motor must stay for a stall stage to occur.

You can set the value of this parameter between 0.0 and $2 \cdot I_H$. For a stall status to occur, the current must be higher than this limit. If parameter ID107 Nominal current limit of motor changes, this parameter is automatically calculated to 90% of the current limit. See Chapter 9.5 *Parameters of stall protection (IDs 709 to 712)*.



NOTE!

The value of the Stall current limit must be below the motor current limit.

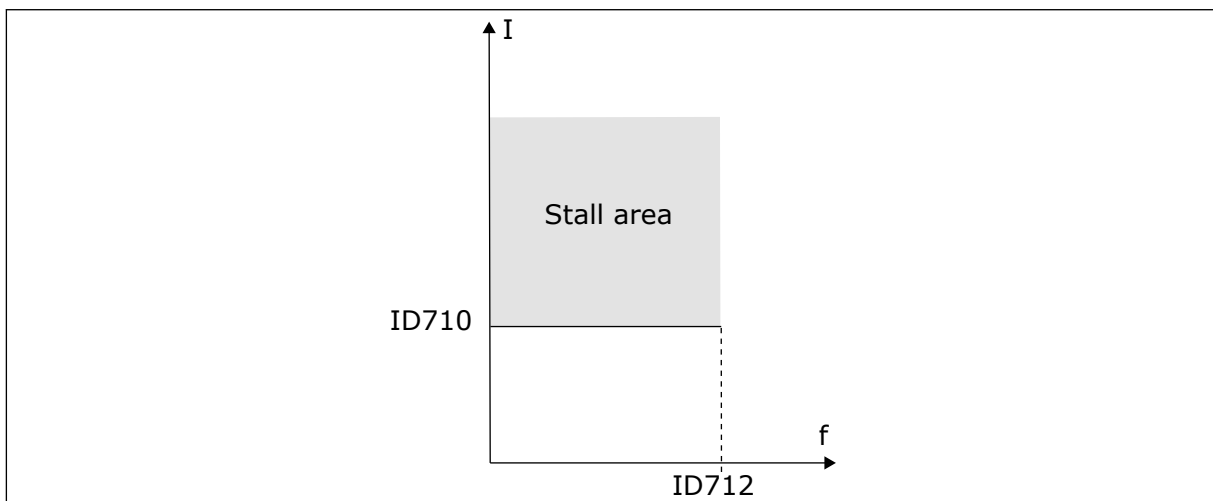

Fig. 74: The stall characteristics settings

711 STALL TIME 234567 (2.7.15)

Use this parameter to set the maximum time for a stall stage.

You can set the time limit between 1.0 and 120.0 s.

This is the maximum time for a stall stage. An internal counter counts the stall time. If the value of the counter goes above this limit, the protection causes the drive to trip (see ID709). See Chapter 9.5 *Parameters of stall protection (IDs 709 to 712)*.

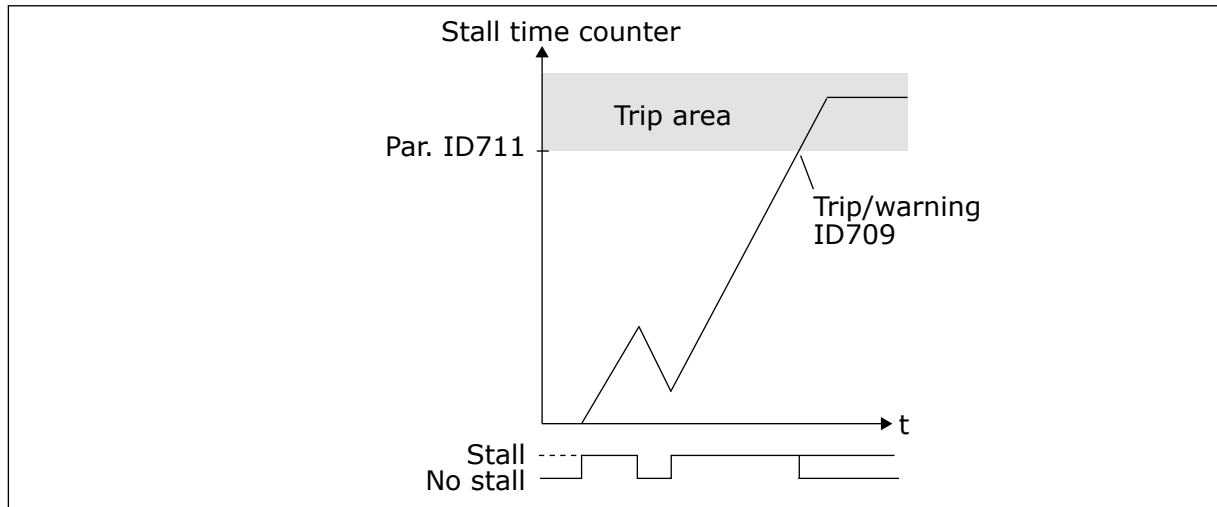

Fig. 75: Stall time count

712 STALL FREQUENCY LIMIT 234567 (2.7.16)

Use this parameter to set the limit below which the output frequency of the drive must stay for a stall stage to occur.

The frequency can be set between $1-f_{max}(ID102)$.

For a stall state to occur, the output frequency must be below this limit for a certain time. See Chapter 9.5 *Parameters of stall protection (IDs 709 to 712)*.

713 UNDERLOAD PROTECTION 234567 (2.7.17)

Use this parameter to select the response of the drive to an 'Underload' fault.

Table 174: Selections for parameter ID713

Selection number	Selection name	Description
0	No response	
1	Warning	
2	Fault, stop mode after fault according to ID506	
3	Fault, stop mode after fault always by coasting	

See Chapter 9.6 *Parameters of underload protection (IDs 713 to 716)*.

714 UNDERLOAD PROTECTION, FIELD WEAKENING AREA LOAD 234567 (2.7.18)

Use this parameter to set the minimum torque that the motor needs when the output frequency of the drive is higher than the frequency of the weakening point.

You can set the value of this parameter between 10.0—150.0 % $\times T_{nMotor}$.

If you change parameter ID113 (Motor nominal current), this parameter goes automatically back to its default value. See Chapter 9.6 *Parameters of underload protection (IDs 713 to 716)*.

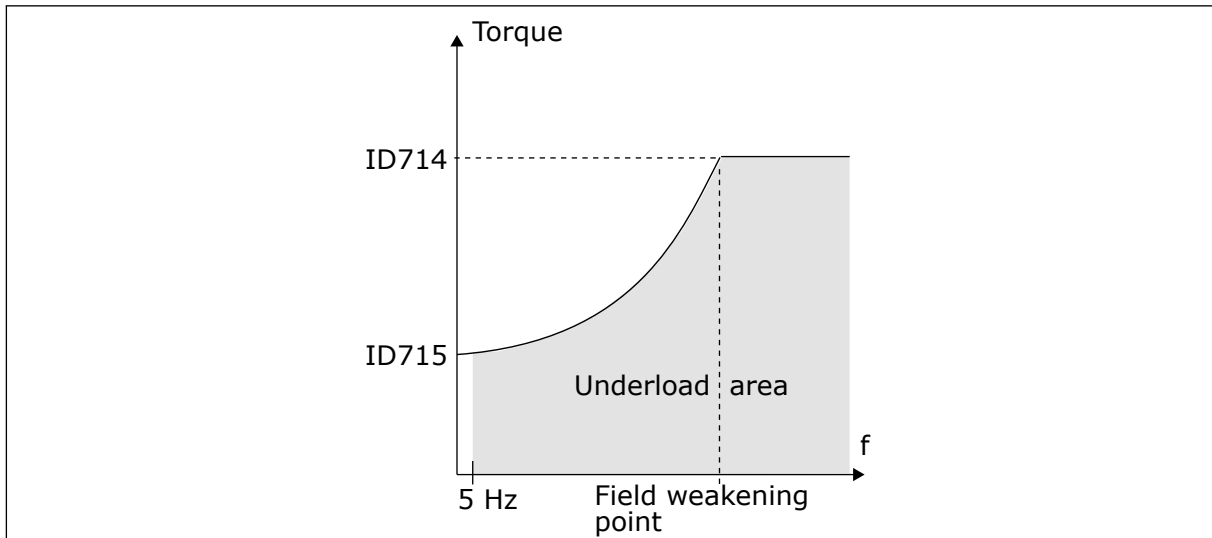

Fig. 76: Setting of the minimum load

715 UNDERLOAD PROTECTION, ZERO FREQUENCY LOAD 234567 (2.7.19)

Use this parameter to set the minimum torque that the motor needs when the output frequency of the drive is 0.

The torque limit can be set between 5.0—150.0 % $\times T_{nMotor}$.

See Fig. 76 *Setting of the minimum load*. If you change the value of parameter ID113 (Motor nominal current), this parameter is automatically restored to the default value. See chapter 9.6 *Parameters of underload protection (IDs 713 to 716)*.

716 UNDERLOAD TIME 234567 (2.7.20)

Use this parameter to set the maximum time for an underload state.

You can set the time limit between 2.0 and 600.0 s.

An internal counter counts the underload time. If the value of the counter goes above this limit, the protection causes the drive to trip. The drive trips as is set in parameter ID713. If the drive stops, the underload counter goes back to 0. See Fig. 77 *The Underload time counter function* and chapter 9.6 *Parameters of underload protection (IDs 713 to 716)*.

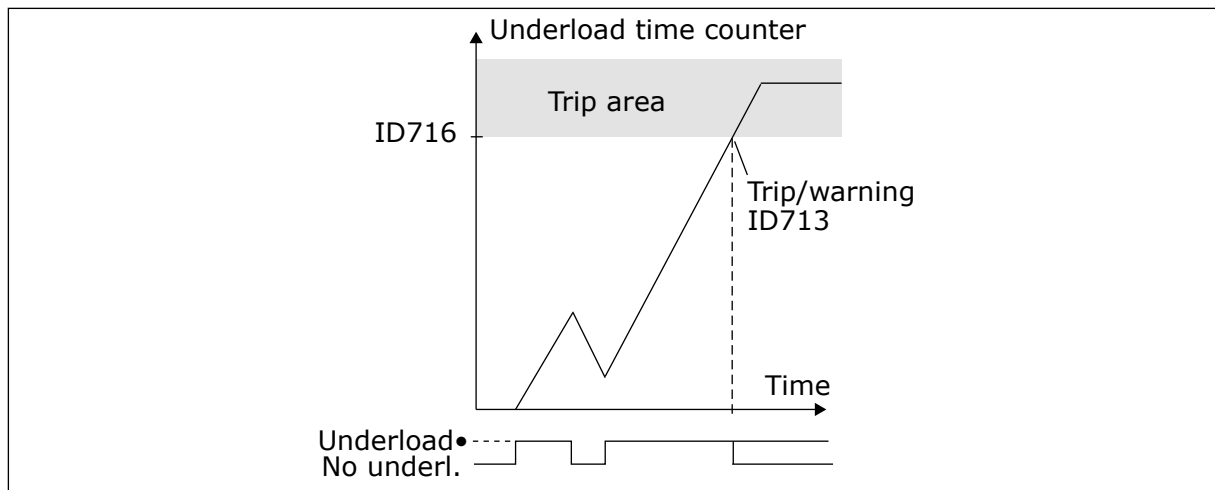

Fig. 77: The Underload time counter function

717 AUTOMATIC RESTART: WAIT TIME 234567 (2.8.1)

Use this parameter to set the wait time before the first reset is done.

718 AUTOMATIC RESTART: TRIAL TIME 234567 (2.8.2)

Use this parameter to set the trial time for the automatic reset function.

During the trial time, the automatic reset function tries to reset the faults that occur. If the number of faults during the trial time exceed the value of the respective parameter set with ID720 to ID725 a permanent fault is generated.

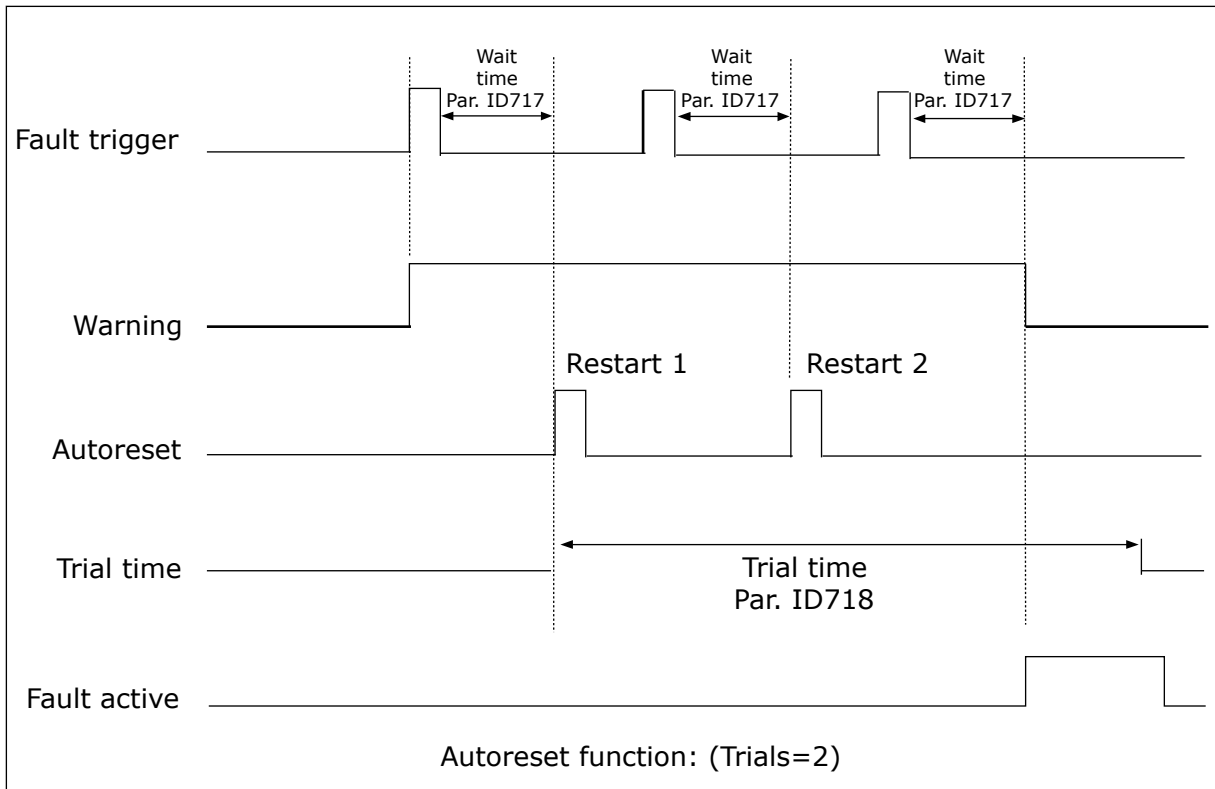

Fig. 78: Example of Automatic restarts with two restarts

Parameters ID720 to ID725 determine the maximum number of automatic restarts during the trial time set by parameter ID718. The time count starts from the first autoreset. If the number of faults occurring during the trial time exceeds the values of parameters ID720 to ID725 the fault state becomes active. Otherwise the fault is cleared after the trial time has elapsed and the next fault start the trial time count again.

If a single fault remains during the trial time, a fault state is true.

719 AUTOMATIC RESTART: START FUNCTION 234567 (2.8.3)

Use this parameter to select the start mode for the Automatic reset function.

Table 175: Selections for parameter ID719

Selection number	Selection name	Description
0	Start with ramp	
1	Flying start	
2	Start according to ID505	

720 AUTOMATIC RESTART: NUMBER OF TRIES AFTER UNDERVOLTAGE FAULT TRIP 234567 (2.8.4)

Use this parameter to set how many automatic restarts the AC drive can make during the set trial time after an undervoltage fault.

Table 176: Selections for parameter ID720

Selection number	Selection name	Description
0	No automatic restart	
>0	Number of automatic restarts after undervoltage fault	The fault is reset and the drive is started automatically after the DC-link voltage has returned to the normal level.

721 AUTOMATIC RESTART: NUMBER OF TRIES AFTER OVERVOLTAGE TRIP 234567 (2.8.5)

Use this parameter to set how many automatic restarts the AC drive can make during the set trial time after an overvoltage fault.

Table 177: Selections for parameter ID721

Selection number	Selection name	Description
0	No automatic restart after overvoltage fault trip	
>0	Number of automatic restarts after overvoltage fault trip.	The fault is reset and the drive is started automatically after the DC-link voltage has returned to the normal level.

722 AUTOMATIC RESTART: NUMBER OF TRIES AFTER OVERCURRENT TRIP 234567 (2.8.6)

Use this parameter to set how many automatic restarts the AC drive can make during the set trial time after an overcurrent fault.



NOTE!

IGBT temp fault also included.

Table 178: Selections for parameter ID722

Selection number	Selection name	Description
0	No automatic restart after overcurrent fault trip	
>0	Number of automatic restarts after overcurrent trip and IGBT temperature faults.	

723 AUTOMATIC RESTART: NUMBER OF TRIES AFTER 4mA REFERENCE TRIP 234567 (2.8.7)

Use this parameter to set how many automatic restarts the AC drive can make during the set trial time after a 4mA fault.

Table 179: Selections for parameter ID 723

Selection number	Selection name	Description
0	No automatic restart after reference fault trip	
>0	Number of automatic restarts after the analogue current signal (4-20mA) has returned to the normal level (>4mA)	

725 AUTOMATIC RESTART: NUMBER OF TRIES AFTER EXTERNAL FAULT TRIP 234567 (2.8.9)

Use this parameter to set how many automatic restarts the AC drive can make during the set trial time after an external fault.

Table 180: Selections for parameter ID725

Selection number	Selection name	Description
0	No automatic restart after External fault trip	
>0	Number of automatic restarts after External fault trip	

726 AUTOMATIC RESTART: NUMBER OF TRIES AFTER MOTOR TEMPERATURE FAULT TRIP 234567 (2.8.8)

Use this parameter to set how many automatic restarts the AC drive can make during the set trial time after a motor temperature fault.

Table 181: Selections for parameter ID726

Selection number	Selection name	Description
0	No automatic restart after Motor temperature fault trip	
>0	Number of automatic restarts after the motor temperature has returned to its normal level	

727 RESPONSE TO UNDERVOLTAGE FAULT 234567 (2.7.5)

Use this parameter to enable the automatic reset after an undervoltage fault.

Table 182: Selections for parameter ID727

Selection number	Selection name	Description
0	Fault stored in fault history	
1	Fault not stored in fault history	

For the undervoltage limits, see the product's User Manual.

728 4mA FAULT FREQUENCY REFERENCE 234567 (2.7.2)

Use this parameter to set the frequency reference of the motor after a 4 mA fault when the response to the 4 mA fault is a warning.

If the value of parameter ID700 is set to 3 and the 4mA fault occurs then the frequency reference to the motor is the value of this parameter.

730 INPUT PHASE SUPERVISION 234567 (2.7.4)

Use this parameter to select the supply phase configuration of the drive.

Table 183: Selections for parameter ID730

Selection number	Selection name	Description
0	No response	
1	Warning	
2	Fault, stop mode after fault according to ID506	
3	Fault, stop mode after fault always by coasting	

The input phase supervision ensures that the input phases of the AC drive have an approximately equal current.

731 AUTOMATIC RESTART 1 (2.20)

Use this parameter to enable the Automatic reset function.

Table 184: Selections for parameter ID731

Selection number	Selection name	Description
0	Disabled	
1	Enabled	

The function resets the following faults (max. three times) (see the product's User Manual:

- Overcurrent (F1)
- Overvoltage (F2)
- Undervoltage (F9)
- Frequency converter overtemperature (F14)
- Motor overtemperature (F16)
- Reference fault (F50)

732 RESPONSE TO THERMISTOR FAULT 234567 (2.7.21)

Use this parameter to select the response of the drive to a 'Thermistor' fault.

Table 185: Selections for parameter ID732

Selection number	Selection name	Description
0	No response	
1	Warning	
2	Fault, stop mode after fault according to ID506	
3	Fault, stop mode after fault always by coasting	

Setting the parameter to 0 will deactivate the protection.

733 RESPONSE TO FIELD BUS FAULT 234567 (2.7.22)

Use this parameter to select the response of the drive to a 'Fieldbus Timeout' fault.

For more information, see the respective Fieldbus Board Manual.

Table 186: Selections for parameter ID733

Selection number	Selection name	Description
0	No Action	No response
1	Warning	Warning
2	Fault	Fault, stop at fault according to parameter ID506
3	Fault, Coast	Fault, stop at fault always by coasting
4	Warn:PresetF	Warning, frequency reference set to fieldbus fault preset frequency (param. ID1801) (*)

(*) NXP drives, Multi-purpose application only.

734 RESPONSE TO SLOT FAULT 234567 (2.7.23)

Use this parameter to select the response of the drive to a 'Slot Communication' fault.

Set here the response mode for a board slot fault due to missing or broken board.

See parameter ID732.

738 AUTOMATIC RESTART: NUMBER OF TRIES AFTER UNDERLOAD FAULT TRIP (2.8.10)

Use this parameter to enable the automatic reset after an underload fault.

Table 187: Selections for parameter ID738

Selection number	Selection name	Description
0	No automatic restart after Underload fault trip	
>0	Number of automatic restarts after Underload fault trip	

739 TBOARD1 NUMBERS (NUMBER OF PT100 INPUTS IN USE) 567 (2.7.24)

Use this parameter to select the number of sensors in use when a temperature board is installed.

**NOTE!**

The parameter name TBoard1 Numbers is used in Multi-Purpose Control Application. The old name (Number of PT100 inputs in use) is still used in PID Control Application and Pump and Fan Control Application.

If you have a temperature board installed in your AC drive you can choose here the number of sensors in use. See also the VACON® NX I/O Boards User Manual.

Table 188: Selections for parameter ID739

Selection number	Selection name	Description
0	Not used	
1	Channel 1	
2	Channel 1 and 2	
3	Channel 1, 2 and 3	
4	Channel 2 and 3	
5	Channel 3	

**NOTE!**

If the selected value is greater than the actual number of used sensors, the display will read 200°C. If the input is short-circuited the displayed value is -30°C.

740 TBOARD FLT.RESP (RESPONSE TO PT100 FAULT) 567 (2.7.25)

Use this parameter to select the response of the drive to 'Temperature' fault.

**NOTE!**

The parameter name TBoard Flt.Resp is used in Multi-Purpose Control Application. The old name (Response to PT100 fault) is still used in PID Control Application and Pump and Fan Control Application.

Table 189: Selections for parameter ID740

Selection number	Selection name	Description
0	No response	
1	Warning	
2	Fault, stop mode after fault according to ID506	
3	Fault, stop mode after fault always by coasting	

741 TBOARD1 WARN.LIM (PT100 WARNING LIMIT) 567 (2.7.26)

Use this parameter to set the temperature warning limit.

**NOTE!**

The parameter name TBoard1 Warn.Lim is used in Multi-Purpose Control Application. The old name (PT100 warning limit) is still used in PID Control Application and Pump and Fan Control Application.

742 TBOARD1 FLT.LIM (PT100 FAULT LIMIT) 567 (2.7.27)

Use this parameter to set the temperature fault limit.

**NOTE!**

The parameter name TBoard1 Flt.Lim is used in Multi-Purpose Control Application. The old name (PT100 fault limit) is still used in PID Control Application and Pump and Fan Control Application.

743 TBOARD2 NUMBERS 6 (2.7.37)

Use this parameter to select the number of sensors in use when a temperature board is installed.

If you have a temperature board installed in your AC drive you can choose here the number of sensors in use. See also the VACON® NX I/O Boards User Manual.

Table 190: Selections for parameter ID743

Selection number	Selection name	Description
0	Not used	
1	Channel 1	
2	Channel 1 & 2	
3	Channel 1 & 2 & 3	
4	Channel 2 & 3	
5	Channel 3	

**NOTE!**

If the selected value is greater than the actual number of used sensors, the display will read 200°C. If the input is short-circuited the displayed value is -30°C.

745 TBOARD2 WARN. LIM 6 (2.7.38)

Use this parameter to set the temperature warning limit.

746 TBOARD2 FLT.LIM 6 (2.7.39)

Use this parameter to set the temperature fault limit.

750 COOLING MONITOR 6 (2.2.7.23)

Use this parameter to select the digital input signal that shows the state of the used cooling unit. This parameter is used for liquid-cooled AC drives.

A fault is generated if the input is low when the drive is in RUN state. If the drive is in STOP state only warning is generated. See the VACON® NX Liquid-Cooled Drives User Manual.

751 COOLING FAULT DELAY 6 (2.7.32)

Use this parameter to set the delay after which the AC drive goes to FAULT state when there is no 'Cooling OK' signal.

752 SPEED ERROR FAULT FUNCTION 6 (2.7.33)

Use this parameter to select the fault response when the speed reference and the encoder speed exceed the set limits.

Table 191: Selections for parameter ID752

Selection number	Selection name	Description
0	No response	
1	Warning	
2	Fault, stop mode after fault always by coasting	

753 SPEED ERROR MAXIMUM DIFFERENCE 6 (2.7.34)

Use this parameter to set the maximum difference between the speed reference and the encoder speed. When the difference goes outside this limit, a fault occurs.

The speed error refers to the difference between the speed reference and the encoder speed. This parameter defines the limit when a fault is generated.

754 SPEED ERROR DELAY 6 (2.7.35)

Use this parameter to set the delay after which the AC drive goes to FAULT state when there is a speed error.

755 SAFE DISABLE MODE 6 (2.7.36)

Use this parameter to select the response to an activated safe disable mode.

**NOTE!**

See separate VACON® NX OPTAF (STO) Board Manual for detailed information on the Safe Disable function. This function is available only if the drive is equipped with VACON® option board OPTAF.

With this parameter it is possible to select whether the activated safe disable function is responded as fault or warning. The safe disable input will stop the drive modulation regardless of this parameter value.

756 SAFE DISABLE ACTIVE 6 (2.3.3.30)

Use this parameter to select the digital output signal that shows the status of the Safe Disable.

776 RESPONSE TO ACTIVE FILTER FAULT 6 (2.7.41)

Use this parameter to set the fault response for the active filter fault.

This parameters defines the response to be triggered when the active filter fault input (set with param. ID214) is closed.

Table 192: Selections for parameter ID776

Selection number	Selection name	Description
0	No Action	No response
1	Warning	Warning
2	Fault	Fault, stop at fault according to parameter ID506
3	Fault, Coast	Fault, stop at fault always by coasting

This parameter is present in NXP drives only.

850 FIELDBUS REFERENCE MINIMUM SCALING 6 (2.9.1)

Use this parameter to set scaling to the fieldbus reference signal.

851 FIELDBUS REFERENCE MAXIMUM SCALING 6 (2.9.2)

Use this parameter to set scaling to the fieldbus reference signal.

If both parameters have the same value, the minimum and maximum frequency limits are used for scaling.

Fig. 79: Fieldbus reference minimum = maximum scaling

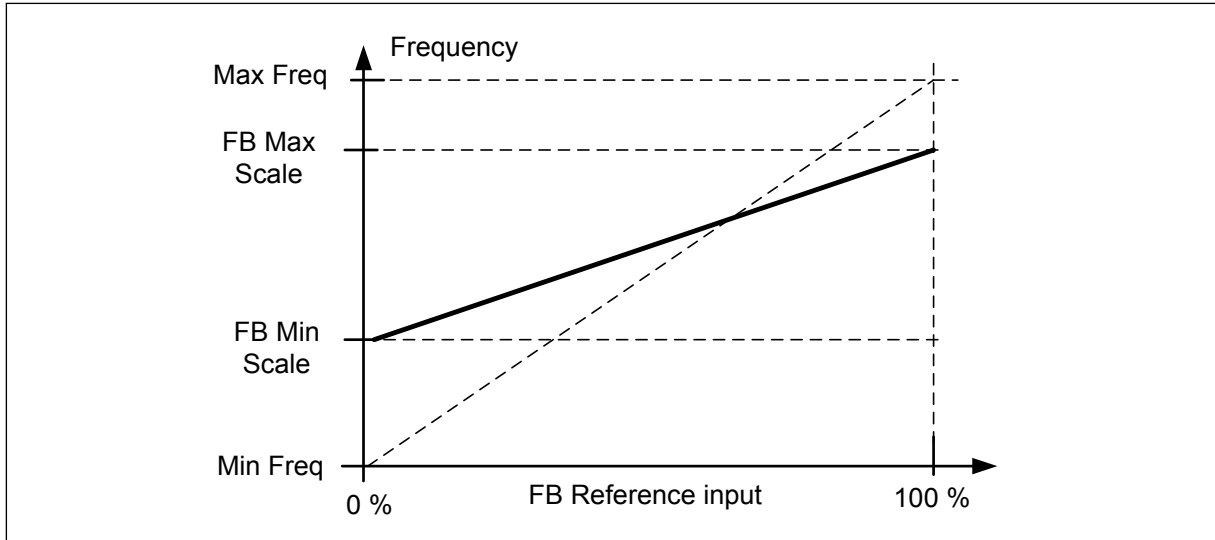

Using this custom scaling function also affects the scaling of the actual value.

Fig. 80: Fieldbus minimum and maximum scaling effect on actual value

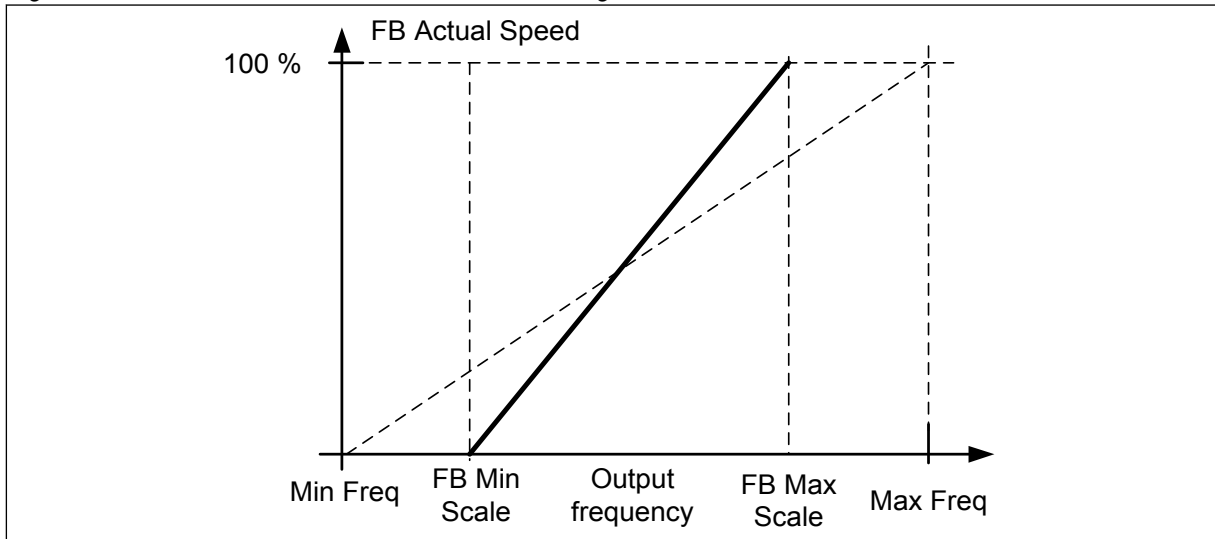

852 TO 859 FIELDBUS DATA OUT SELECTIONS 1 TO 8 6 (2.9.3 TO 2.9.10)

Use this parameter to select the data that is sent to the fieldbus with the ID number of the parameter or monitor value.

Enter the ID number of the item you wish to monitor for the value of these parameters. See Chapter 9.7 *Fieldbus control parameters (IDs 850 to 859)*.

1	Output frequency	15	Digital inputs 1,2,3 statuses
2	Motor speed	16	Digital inputs 4,5,6 statuses
3	Motor current	17	Digital and relay output statuses
4	Motor torque	25	Frequency reference
5	Motor power	26	Analogue output current
6	Motor voltage	27	AI3
7	DC link voltage	28	AI4
8	Unit temperature	31	A01 (expander board)
9	Motor temperature	32	A02 (expander board)
13	AI1	37	Active fault 1
14	AI2	45	Motor current (drive independent) given with one decimal point

See also Chapter 6.4.1 *Monitoring values (Control keypad: Menu M1)* for more monitoring values.

876 TO 883 FIELDBUS DATA IN SELECTIONS 1 TO 8 6 (2.9.19 TO 2.9.26)

Use this parameter to select a parameter or monitoring value to be controlled from the fieldbus.

Enter the ID number of the item you wish to control for the value of these parameters. See *Table 45 Monitoring values, NXP drives*.

896 FIELDBUS STATE MACHINE 6 (2.9.35)

Use this parameter to select the control profile (state machine) for the fieldbus control.



NOTE!

If ProfiDrive mode is selected, the fieldbus option board has to be set to bypass mode. See Chapter 9.15 *Fieldbus control in detail* for further information.

Table 194: Selections for parameter ID896

Selection number	Selection name	Description
0	Standard	This mode makes the fieldbus control behave as explained in the used fieldbus option board manual.
1	ProfiDrive	This mode uses ProfiDrive state machine in application software. This mode is possible to use only with the fieldbus boards that do not have their own state machine or have the possibility to bypass state machine functionality in the option board.

1001 NUMBER OF AUXILIARY DRIVES 7 (2.9.1)

Use this parameter to set the total number of auxiliary drives.

The functions controlling the auxiliary drives (parameters ID458 to ID462) can be programmed to relay outputs or digital output. By default, one auxiliary drive is in use and it is programmed to relay output R01 at B.1.

1002 START FREQUENCY, AUXILIARY DRIVE 17 (2.9.2)

Use this parameter to set the limit for the frequency of the AC drive that starts the auxiliary drive.

The frequency of the drive controlled by the AC drive must exceed the limit defined with these parameters with 1 Hz before the auxiliary drive is started. The 1 Hz overdraft makes a hysteresis to avoid unnecessary starts and stops. See *Fig. 81 Example of parameter setting; Variable speed drive and one auxiliary drive*, ID101 and ID102.

1003 STOP FREQUENCY, AUXILIARY DRIVE 17 (2.9.3)

Use this parameter to set the limit for the frequency of the AC drive that stops the auxiliary drive.

The frequency of the drive controlled by the AC drive must fall with 1 Hz below the limit defined with these parameters before the auxiliary drive is stopped. The stop frequency limit also defines the frequency to which the frequency of the drive controlled by the AC drive is dropped after starting the auxiliary drive. See *Fig. 81 Example of parameter setting; Variable speed drive and one auxiliary drive*.

1004 START FREQUENCY, AUXILIARY DRIVE 27 (2.9.4)

Use this parameter to set the limit for the frequency of the AC drive that starts the auxiliary drive.

1005 STOP FREQUENCY, AUXILIARY DRIVE 27 (2.9.5)

Use this parameter to set the limit for the frequency of the AC drive that stops the auxiliary drive.

1006 START FREQUENCY, AUXILIARY DRIVE 37 (2.9.6)

Use this parameter to set the limit for the frequency of the AC drive that starts the auxiliary drive.

1007 STOP FREQUENCY, AUXILIARY DRIVE 37 (2.9.7)

Use this parameter to set the limit for the frequency of the AC drive that stops the auxiliary drive.

1008 START FREQUENCY, AUXILIARY DRIVE 47 (2.9.8)

Use this parameter to set the limit for the frequency of the AC drive that starts the auxiliary drive.

1009 STOP FREQUENCY, AUXILIARY DRIVE 47 (2.9.9)

Use this parameter to set the limit for the frequency of the AC drive that stops the auxiliary drive.

See parameters ID1002 and ID1003.

1010 START DELAY OF AUXILIARY DRIVES 7 (2.9.10)

Use this parameter to set the delay time to start the auxiliary drive.

The frequency of the drive controlled by the AC drive must remain above the start frequency of the auxiliary drive for the time defined with this parameter before the auxiliary drive is started. The delay defined applies to all auxiliary drives. This prevents unnecessary starts caused by momentary start limit exceedings. See *Fig. 81 Example of parameter setting; Variable speed drive and one auxiliary drive.*

1011 STOP DELAY OF AUXILIARY DRIVES 7 (2.9.11)

Use this parameter to set the delay time to stop the auxiliary drive.

The frequency of the drive controlled by the AC drive must remain below the stop limit of the auxiliary drive for the time defined with this parameter before the drive is stopped. The delay defined applies to all auxiliary drives. This prevents unnecessary stops caused by momentary falls below the stop limit.

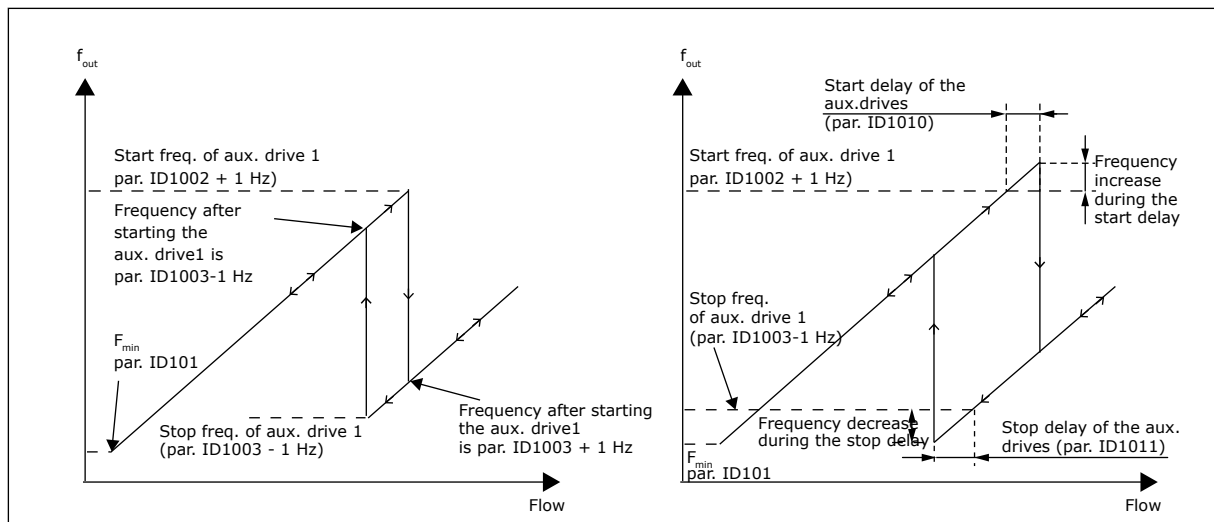

Fig. 81: Example of parameter setting; Variable speed drive and one auxiliary drive

1012 REFERENCE STEP AFTER START OF AUXILIARY DRIVE 17 (2.9.12)

Use this parameter to set a reference step that is added to the reference value when the auxiliary drive is started.

1013 REFERENCE STEP AFTER START OF AUXILIARY DRIVE 27 (2.9.13)

Use this parameter to set a reference step that is added to the reference value when the auxiliary drive is started.

1014 REFERENCE STEP AFTER START OF AUXILIARY DRIVE 37 (2.9.14)

Use this parameter to set a reference step that is added to the reference value when the auxiliary drive is started.

1015 REFERENCE STEP AFTER START OF AUXILIARY DRIVE 47 (2.9.15)

Use this parameter to set a reference step that is added to the reference value when the auxiliary drive is started.

The reference step will be automatically added to the reference value always when the corresponding auxiliary drive is started. With the reference steps e.g. the pressure loss in the piping caused by the increased flow can be compensated.

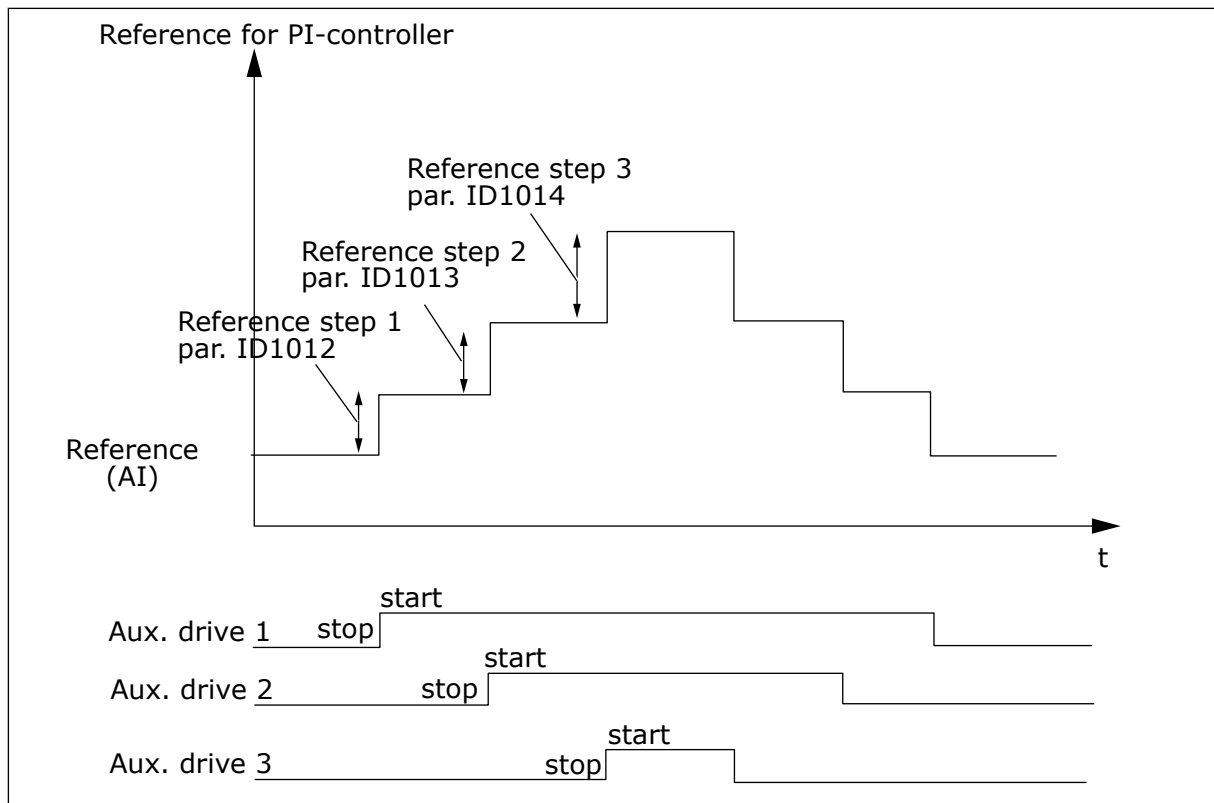

Fig. 82: Reference steps after starting auxiliary drives

1016 SLEEP FREQUENCY 57 (2.1.15)

Use this parameter to set the limit below which the output frequency of the drive must stay for a set time before the drive goes to the sleep state.

The drive goes to sleep mode (that is, the drive stops) when the output frequency of the drive is less than the frequency limit that is set in this parameter for a time greater than that determined by parameter ID1017. During the Stop state, the PID controller is operating switching the AC drive to Run state when the actual value signal either falls below or exceeds (see parameter ID1019) the Wake-up level determined by parameter ID1018. See Fig. 83 AC drive sleep function.

1017 SLEEP DELAY 57 (2.1.16)

Use this parameter to set the minimum duration that the output frequency of the drive must stay below the set limit before the drive goes to the sleep state.

See Fig. 83 AC drive sleep function.

1018 WAKE-UP LEVEL 57 (2.1.17)

Use this parameter to set the level at which the drive wakes up from the sleep state.

The wake-up level defines the level below which the actual value must fall or which has to be exceeded before the Run state of the AC drive is restored.

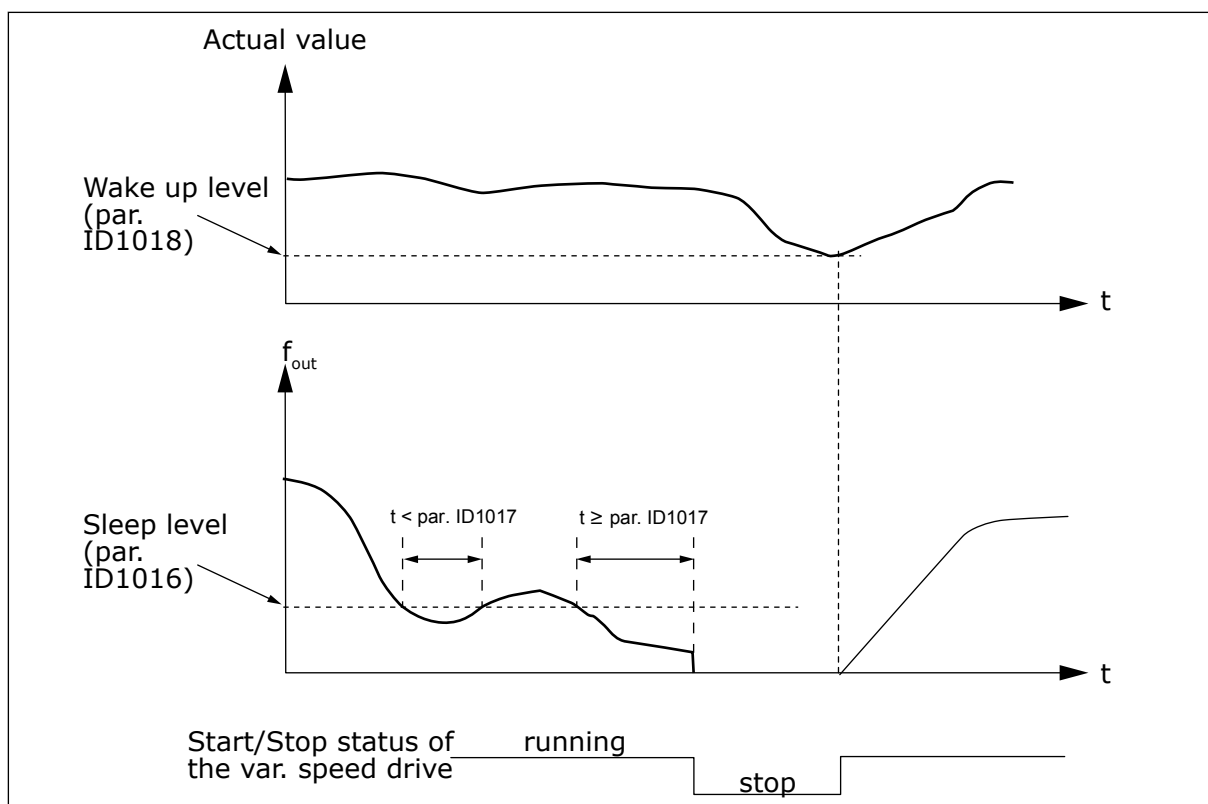

Fig. 83: AC drive sleep function

1019 WAKE-UP FUNCTION 57 (2.1.18)

Use this parameter to select the operation for the wake up level parameter.

This parameter defines whether the restoration of the Run state occurs when the actual value signal falls below or exceeds the Wake-up level (parameter ID1018). See Chapter 1018 *Wake-up level 57 (2.1.17)* and Table 195.

The application 5 has selections 0-1 and application 7 selections 0-3 available.

Table 195: Selectable wake-up functions

Selection number	Function	Limit	Description
0	Wake-up happens when actual value goes below the limit	The limit defined with parameter ID1018 is in percent of the maximum actual value	<p>Actual value signal</p>  <p>100%</p> <p>Par. ID1018=30%</p> <p>t</p> <p>Start</p> <p>Stop</p>
1	Wake-up happens when actual value exceeds the limit	The limit defined with parameter ID1018 is in percent of the maximum actual value	<p>Actual value signal</p>  <p>100%</p> <p>Par. ID1018=60%</p> <p>t</p> <p>Start</p> <p>Stop</p>

Table 195: Selectable wake-up functions

Selection number	Function	Limit	Description
2	Wake up happens when actual value goes below the limit	The limit defined with parameter ID1018 is in percent of the current value of the reference signal	<p>Actual value signal</p>  <p>100%</p> <p>reference=50%</p> <p>Par. ID1018=60%</p> <p>limit=60%*reference=30%</p> <p>t</p> <p>Start</p> <p>Stop</p>
3	Wake up happens when actual value exceeds the limit	The limit defined with parameter ID1018 is in percent of the current value of the reference signal	<p>Actual value signal</p>  <p>100%</p> <p>Par. ID1018=140%</p> <p>limit=140%*reference=70%</p> <p>reference=50%</p> <p>t</p> <p>Start</p> <p>Stop</p>

1020 PID CONTROLLER BYPASS 7 (2.9.16)

Use this parameter to select if the PID controller is bypassed.

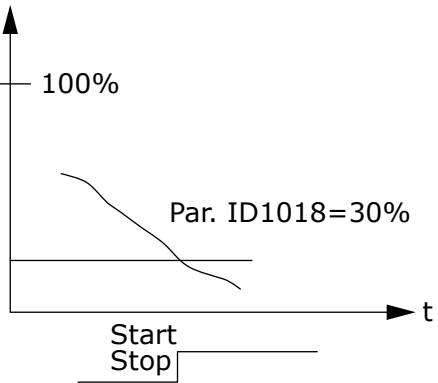
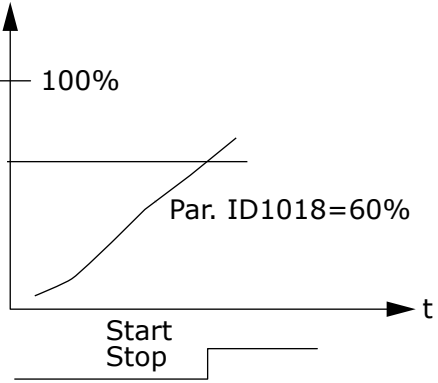
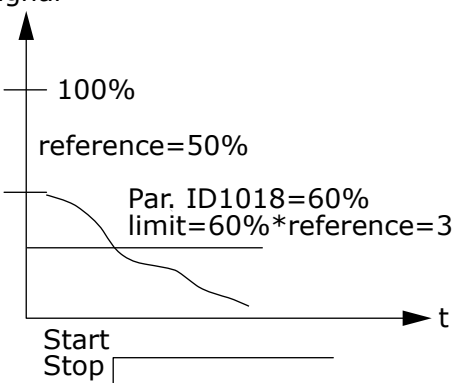
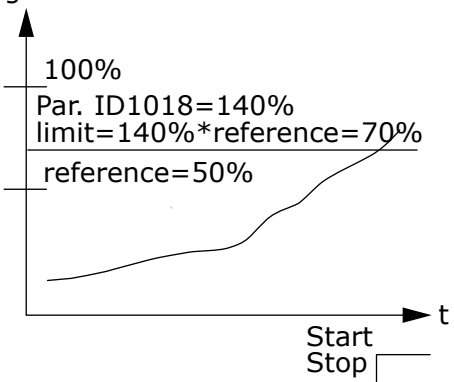
Then the frequency of the controlled drive and the starting points of the auxiliary drives are defined according to the actual value signal.

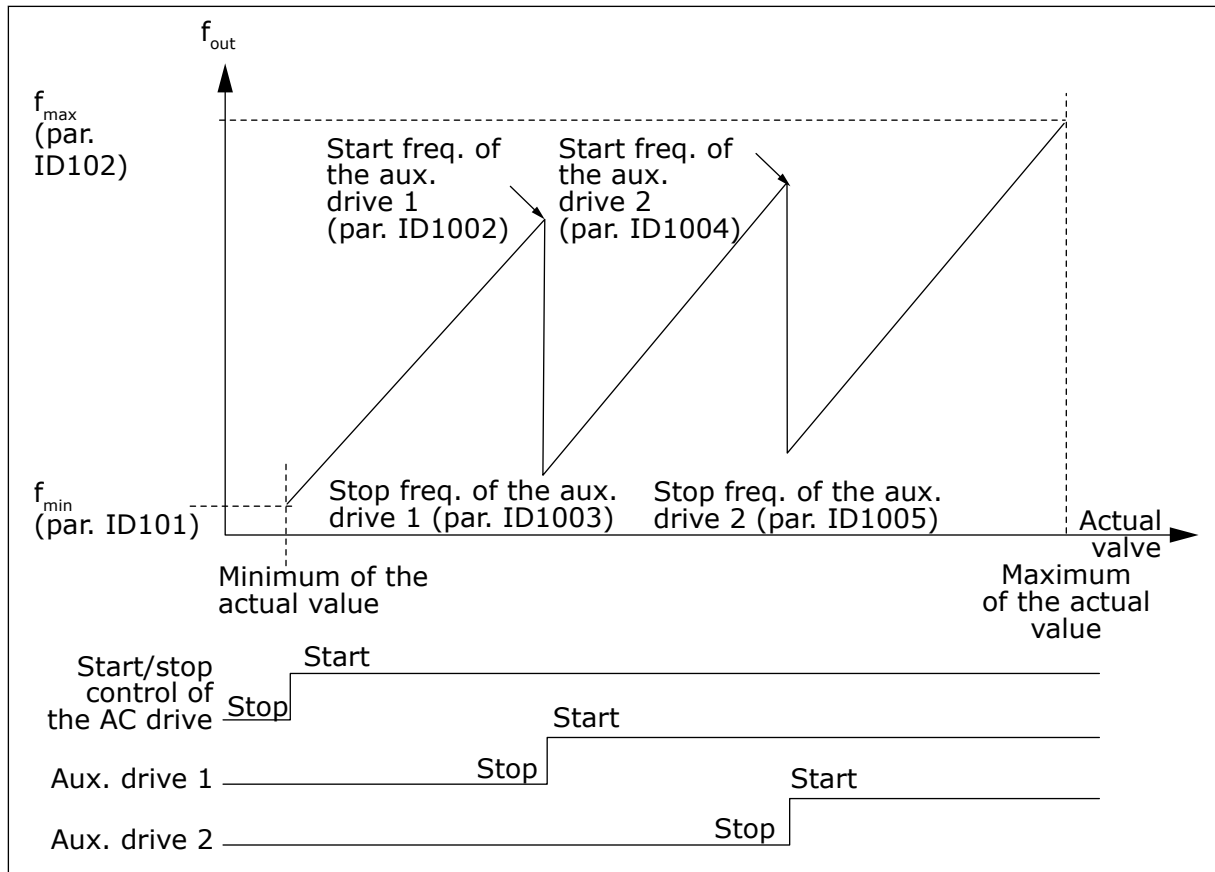

Fig. 84: Example of variable speed drive and two auxiliary drives with bypassed PID controller

1021 ANALOGUE INPUT SELECTION FOR INPUT PRESSURE MEASUREMENT 7 (2.9.17)

Use this parameter to select the analogue input signal for which you want to set the input pressure measurement.

1022 INPUT PRESSURE HIGH LIMIT 7 (2.9.18)

Use this parameter to set the high limit for the analogue input you selected for the input pressure measurement.

1023 INPUT PRESSURE LOW LIMIT 7 (2.9.19)

Use this parameter to set the low limit for the analogue input you selected for the input pressure measurement.

1024 OUTPUT PRESSURE DROP VALUE 7 (2.9.20)

Use this parameter to set the decrease in output pressure when the input pressure goes below the input pressure low limit.

In pressure increase stations there may be need for decreasing the output pressure if the input pressure decreases below a certain limit. The input pressure measurement which is needed is connected to the analogue input selected with parameter ID1021.

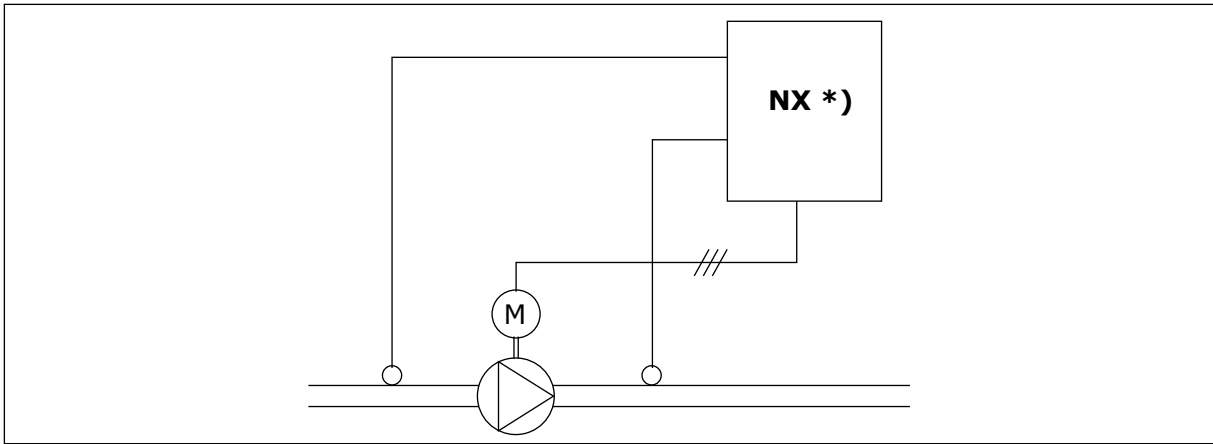

Fig. 85: Input and output pressure measuring

*)

- Input pressure measurement selected with par. ID1021
- PI-controller actual value input par. ID333

With parameters ID1022 and ID1023 the limits for the area of the input pressure, where the output pressure is decreased, can be selected. The values are in percent of the input pressure measurement maximum value. With parameter ID1024 the value for the output pressure decrease within this area can be set. The value is in percent of the reference value maximum.

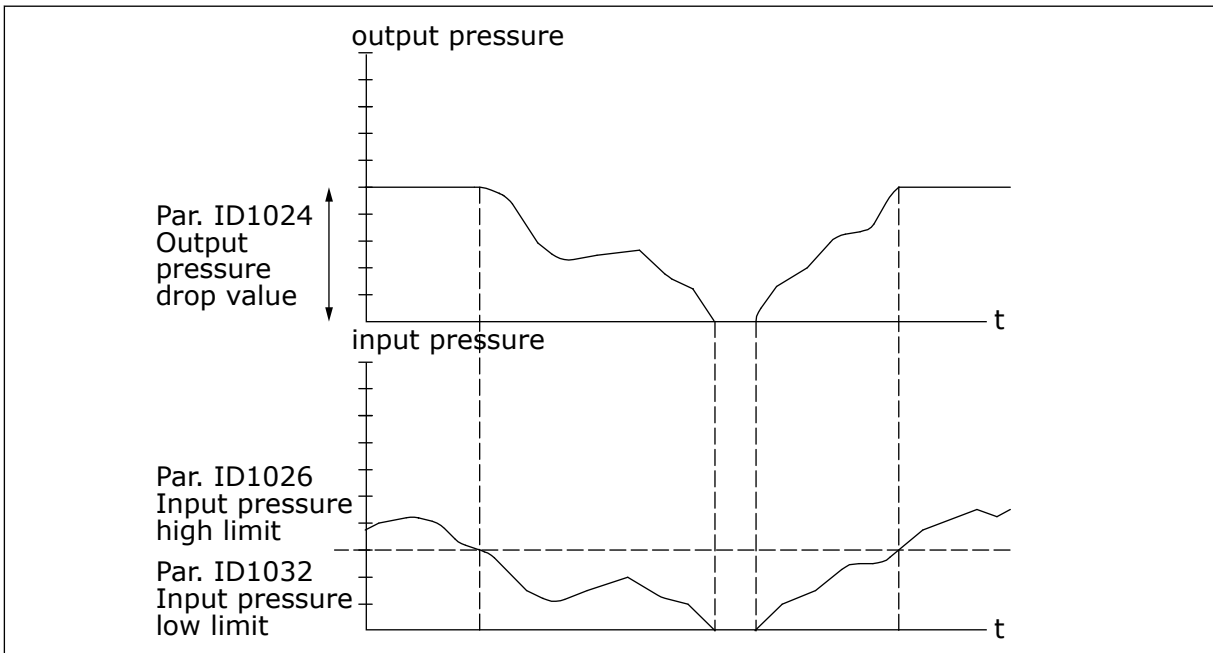

Fig. 86: Output pressure behaviour depending on input pressure and parameter settings

1025 FREQUENCY DROP DELAY AFTER STARTING AUXILIARY DRIVE 7 (2.9.21)

Use this parameter to set the delay time after which the frequency is decreased after the auxiliary drive is started.

1026 FREQUENCY INCREASE DELAY AFTER STOPPING AUXILIARY DRIVE 7 (2.9.22)

Use this parameter to set the delay time after which the frequency is increased after the auxiliary drive is stopped.

If the speed of auxiliary drive increases slowly (e.g. in soft starter control) then a delay between the start of auxiliary drive and the frequency drop of the variable speed drive will make the control smoother. This delay can be adjusted with parameter ID1025.

In the same way, if the speed of the auxiliary drives decreases slowly a delay between the auxiliary drive stop and the frequency increase of the variable speed drive can be programmed with parameter ID1026.

If either of the values of parameters ID1025 and ID1026 is set to maximum (300.0 s) no frequency drop nor increase takes place.

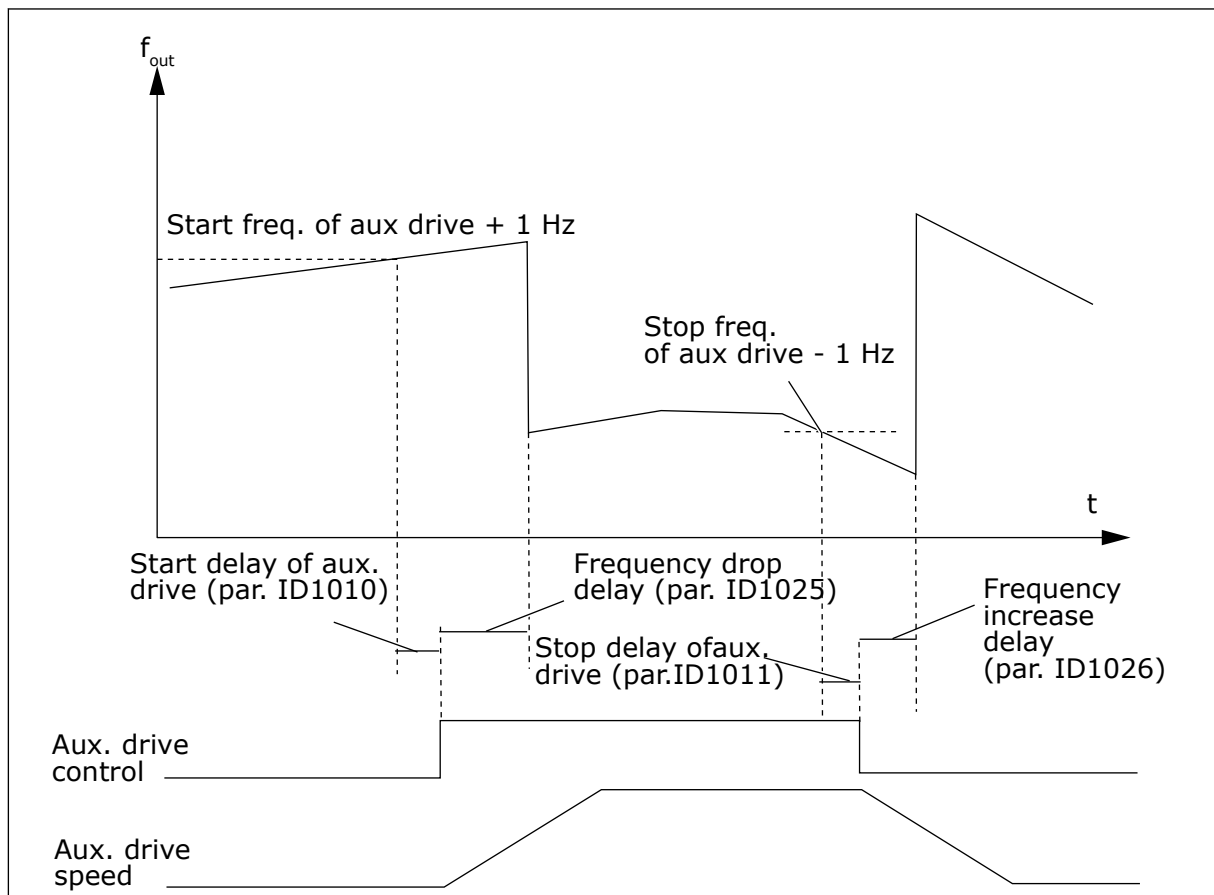

Fig. 87: Frequency drop and increase delays

1027 AUTOCHANGE 7 (2.9.24)

Use this parameter to enable or disable the rotation of the start sequence and the priority of motors.

Table 196: Selections for parameter ID1027

Selection number	Selection name	Description
0	Autochange not used	
1	Autochange used	

1028 AUTOCHANGE/INTERLOCKS AUTOMATICS SELECTION 7 (2.9.25)

Use this parameter to select if the autochange is applied to the auxiliary drives or all drives.

Table 197: Selections for parameter ID1028

Selection number	Selection name	Description
0	Automatics (autochange/interlockings) applied to auxiliary drives only	The drive controlled by the AC drive remains the same. Only the mains contactor is needed for each drive. See Fig. 88 <i>Autochange applied to auxiliary drives only.</i>
1	All drives included in the autochange/interlockings sequence	The drive controlled by the AC drive is included in the autochange and two contactors are needed for each drive to connect it to the mains or the AC drive. See Fig. 89 <i>Autochange with all drives.</i>

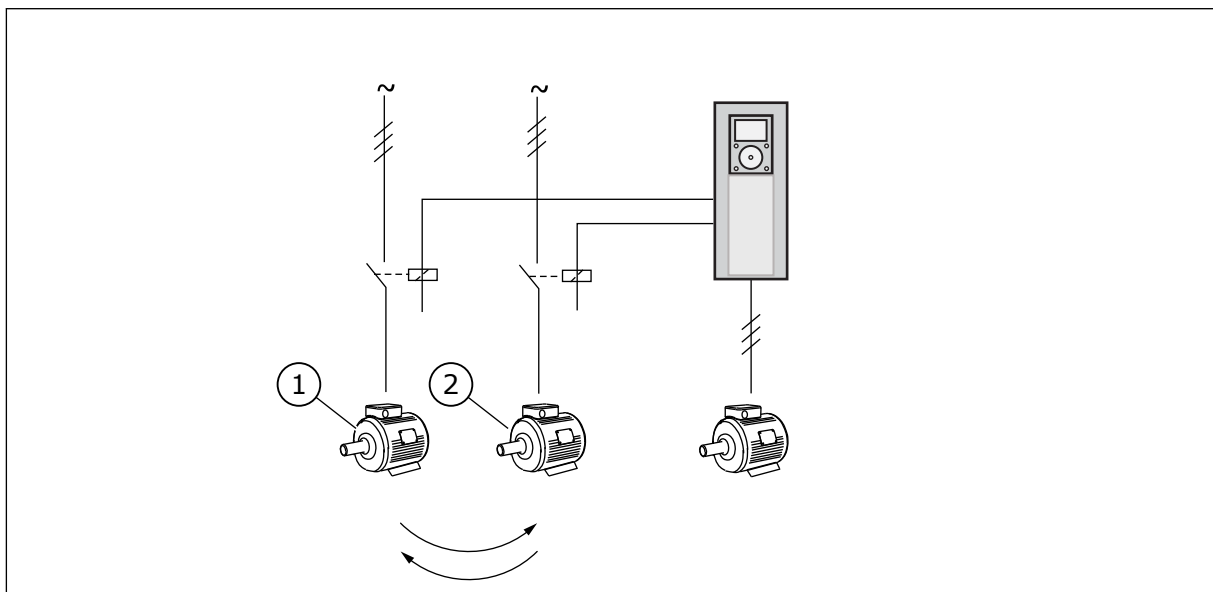

Fig. 88: Autochange applied to auxiliary drives only

1. Motor aux.1

2. Motor aux.2

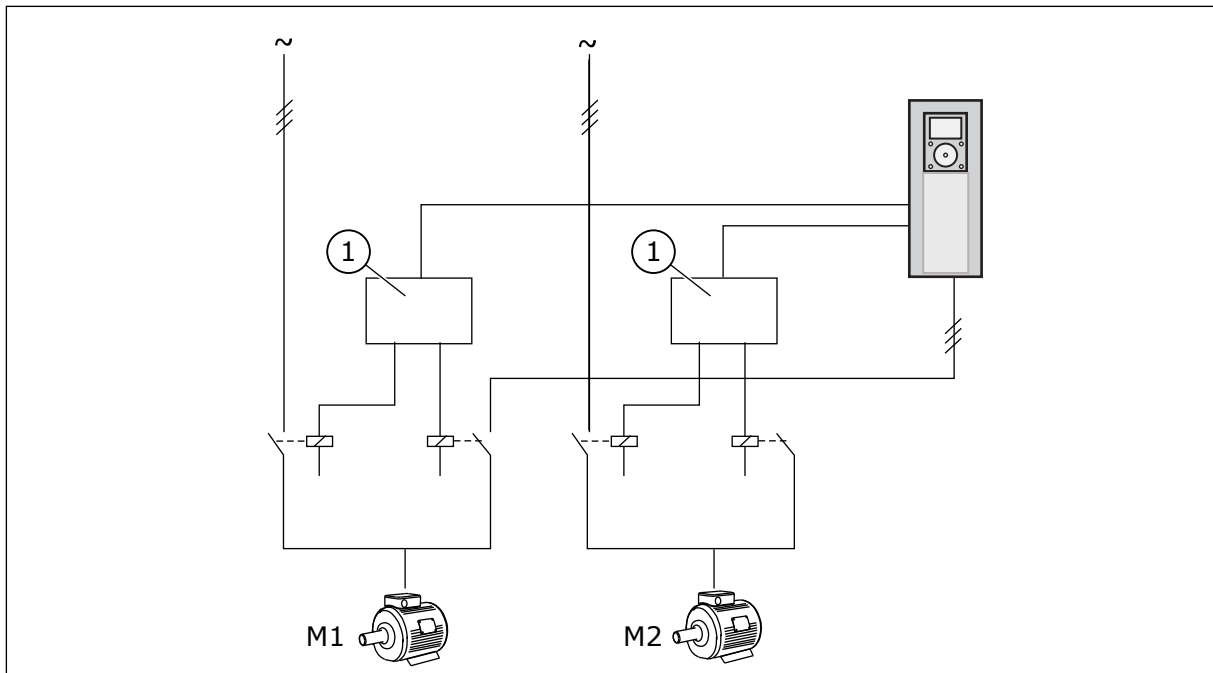

Fig. 89: Autochange with all drives

1. Auxiliary connection

1029 AUTOCHANGE INTERVAL 7 (2.9.26)

Use this parameter to adjust the autochange intervals.

When this time is over, the autochange occurs if the capacity is below the level set with parameters ID1031 (Autochange frequency limit) and ID1030 (Maximum number of auxiliary drives). Should the capacity exceed the value of ID1031, the autochange will not take place before the capacity goes below this limit.

The time count is activated only if the Start/Stop request is active.

The time count is reset after the autochange has taken place.

See Chapter *1031 Autochange frequency limit 7 (2.9.28)*.

1030 MAXIMUM NUMBER OF AUXILIARY DRIVES 7 (2.9.27)

Use this parameter to set the amount of auxiliary drives used.

1031 AUTOCHANGE FREQUENCY LIMIT 7 (2.9.28)

Use this parameter to set the autochange frequency limit.

These parameters define the level below which the capacity used must remain so that the autochange can take place.

This level is defined as follows:

- If the number of running auxiliary drives is smaller than the value of parameter ID1030 the autochange function can take place.
- If the number of running auxiliary drives is equal to the value of parameter ID1030 and the frequency of the controlled drive is below the value of parameter ID1031 the autochange can take place.
- If the value of parameter ID1031 is 0.0 Hz, the autochange can take place only in rest position (Stop and Sleep) regardless of the value of parameter ID1030.

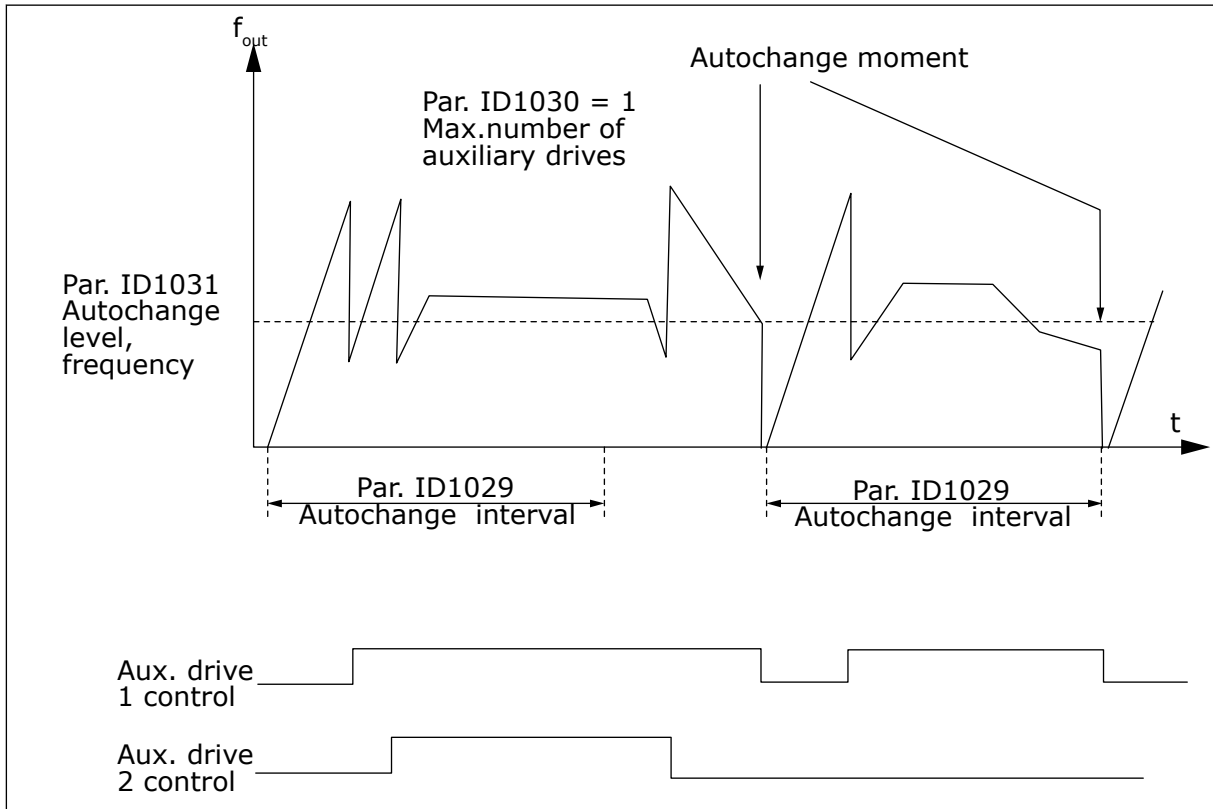

Fig. 90: Autochange interval and limits

1032 INTERLOCK SELECTION 7 (2.9.23)

Use this parameter to enable or disable the interlocks.

The interlock feedback signals come from the switches that connect the motors to the automatic control (AC drive), directly to the mains or place them to off-state. The interlock feedback functions are connected to the digital inputs of the AC drive. Program parameters ID426 to ID430 to connect the feedback functions to the digital inputs. Each drive must be connected to its own interlock input. The Pump and fan control controls only those motors whose interlock input is active.

Table 198: Selections for parameter ID1032

Selection number	Selection name	Description
0	Interlock feedback not used	The AC drive receives no interlock feedback from the drives
1	Update of autochange order in Stop	The AC drive receives interlock feedback from the drives. In case one of the drives is, for some reason, disconnected from the system and eventually reconnected, it will be placed last in the autochange line without stopping the system. However, if the autochange order now becomes, for example, [P1 -> P3 -> P4 -> P2], it will be updated in the next Stop (autochange, sleep, stop, etc.) EXAMPLE: [P1-> P3 -> P4] -> [P2 LOCKED] -> [P1 -> P3 -> P4 -> P2] -> [SLEEP] -> [P1 -> P2 -> P3 -> P4]
2	Update of order immediately	The AC drive receives interlock feedback from the drives. At reconnection of a drive to the autochange line, the automatics will stop all motors immediately and re-start with a new set-up. EXAMPLE: [P1 -> P2 -> P4] -> [P3 LOCKED] -> [STOP] -> [P1 -> P2 -> P3 -> P4]

1033 ACTUAL VALUE SPECIAL DISPLAY MINIMUM 57 (2.2.46, 2.9.29)

Use this parameter to set the minimum value of the special display.

1034 ACTUAL VALUE SPECIAL DISPLAY MAXIMUM 57 (2.2.47, 2.9.30)

Use this parameter to set the maximum value of the special display.

1035 ACTUAL VALUE SPECIAL DISPLAY DECIMALS 57 (2.2.48, 2.9.31)

Use this parameter to set the decimals of the special display.

1036 ACTUAL VALUE SPECIAL DISPLAY UNIT 57 (2.2.49, 2.9.32)

Use this parameter to select the unit of the special display.

The Actual value special display parameters are used to convert and display the actual value signal in a form more informative to the user.

The Actual value special display parameters are available in PID Control Application and Pump and Fan Control Application.

EXAMPLE:

The actual value signal sent from a sensor (in mA) tells you the amount of waste water pumped from a tank per second. The signal range is 0(4)-20 mA. Instead of receiving the

level of the actual value signal (in mA) on the display, you wish to receive the amount of water pumped in m³/s. You then set a value for parameter ID1033 to correspond to the minimum signal level (0/4 mA) and another value for parameter ID1034 to correspond to the maximum signal level (20 mA). The number of decimals needed can be set with parameter ID1035 and the unit (m³/s) with parameter ID1036. The level of the actual value signal is then scaled between the set min and max values and displayed in the selected unit.

The following units can be selected (parameter ID1036):

Table 199: Selectable values for Actual Value Special Display

Value	Unit	On keypad
0	Not used	
1	%	%
2	°C	°C
3	m	m
4	bar	bar
5	mbar	mbar
6	Pa	Pa
7	kPa	kPa
8	PSI	PSI
9	m/s	m/s
10	l/s	l/s
11	l/min	l/m
12	l/h	l/h
13	m ³ /s	m ³ /s
14	m ³ /min	m ³ /m
15	m ³ /h	m ³ /h
16	°F	°F
17	ft	ft
18	gal/s	GPS
19	gal/min	GPM
20	gal/h	GPH
21	ft ³ /s	CFS
22	ft ³ /min	CFM
23	ft ³ /h	CFH
24	A	A
25	V	V
26	W	W

Table 199: Selectable values for Actual Value Special Display

Value	Unit	On keypad
27	kW	kW
28	Hp	Hp
29 *	Inch	Inch

* = Valid only for Application 5 (PID Control Application).

**NOTE!**

The maximum number of characters that can be shown on keypad is 4. This means that in some cases the display of the unit on the keypad does not comply with the standards.

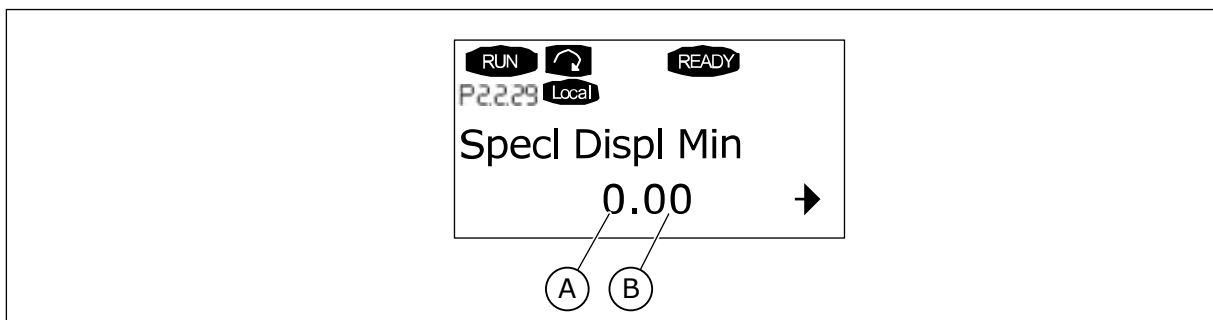

Fig. 91: Display example

A. Actual value min (max)

B. Number of decimals

1080 DC-BRAKE CURRENT AT STOP 6 (2.4.14)

Use this parameter to set the current fed to the motor in stop state when the DC braking is active.

In the Multi-Purpose Control application, this parameter defines the current injected to the motor in stop state when parameter ID416 is active. In all other applications this value is fixed to a tenth of the DC brake current.

The parameter is available for NXP drives only.

1081 FOLLOWER REFERENCE SELECTION 6 (2.11.3)

Use this parameter to select the speed reference to the follower drive.

Table 200: Selections for parameter ID1081

Selection number	Function	Description
0	Analogue input 1 (AI1)	See ID377
1	Anlogue input 2 (AI2)	See ID388
2	AI1+AI2	
3	AI1-AI2	
4	AI2-AI1	
5	AI1*AI2	
6	AI1 joystick	
7	AI2 joystick	
8	Keypad reference (R3.2)	
9	Fieldbus reference	
10	Potentiometer reference; controlled with ID418 (TRUE=increase) and ID417 (TRUE=decrease)	
11	AI1 or AI2, whichever is lower	
12	AI1 or AI2, whichever is greater	
13	Max. frequency ID102 (recommended in torque control only)	
14	AI1/AI2 selection	See ID422
15	Encoder 1 (AI input C.1)	
16	Encoder 2 (With OPTA7 Speed Synchronization, NXP only AI input C.3)	
17	Master Reference	
18	Master Ramp Out (default)	

1082 SYSTEMBUS COMMUNICATION FAULT RESPONSE 6 (2.7.30)

Use this parameter to select the response of the drive to an 'SystemBus communication'.

Table 201: Selections for parameter ID1082

Selection number	Selection name	Description
0	No response	
1	Warning	
2	Fault, stop mode after fault according to ID506	
3	Fault, stop mode after fault always by coasting	

1083 FOLLOWER TORQUE REFERENCE SELECTION 6 (2.11.4)

Use this parameter to select the torque reference for the follower drive.

1084 CONTROL OPTIONS 6 (2.4.19)

Use this parameter to select the control option.

The parameter is available for NXP drives only.

Table 202: Selections for parameter ID1084

Selection number	Selection name	Description
b0	Disables encoder fault	
b1	Update Ramp Generator when MotorControlMode changes from TC (4) to SC (3)	
b2	RampUp; use acceleration ramp (for Closed Loop torque control)	
b3	RampDown; use deceleration ramp (for Closed Loop torque control)	
b4	FollowActual; follow actual speed value within WindowPos/ NegWidth (for closed loop torque control)	
b5	TC ForceRampStop; Under stop request the speed limit forces the motor to stop	
b6	Reserved	
b7	Disables switching frequency decrease	
b8	Disable the parameter "Run state parameter lock"	
b9	Reserved	
b10	Invert delayed digital output 1	
b11	Invert delayed digital output 2	

1085 BRAKE ON/OFF CURRENT LIMIT 6 (2.3.4.16)

Use this parameter to set the brake current limit.

The mechanical brake closes immediately if the motor current is below this value.

This parameter is available for NXP drives only.

1087 SCALING OF GENERATING TORQUE LIMIT 6 (2.2.6.6)

Use this parameter to select the analogue input signal that adjusts the maximum motor generating torque.

Table 203: Selections for parameter ID1087

Selection number	Selection name	Description
0	Parameter	
1	AI1	
2	AI2	
3	AI3	
4	AI4	
5	FB limit scaling	

This signal will adjust the maximum motor generating torque between 0 and max. limit set with parameter ID1288. Analogue input level zero means zero generator torque limit. This parameter is available for NXP drives only.

1088 SCALING OF GENERATING POWER LIMIT 6 (2.2.6.8)

Use this parameter to select the analogue input signal that adjusts the maximum motor generating power.

Table 204: Selections for parameter ID1088

Selection number	Selection name	Description
0	Parameter	
1	AI1	
2	AI2	
3	AI3	
4	AI4	
5	FB limit scaling	

This signal will adjust the maximum motor generating power between 0 and max. limit set with parameter ID1290 This parameter is available for Closed Loop control mode only. Analogue input level zero means zero generator power limit.

1089 FOLLOWER STOP FUNCTION 6 (2.11.2)

Use this parameter to select how the follower drive stops.

Defines how the follower drive stops (when selected follower reference is not Master's ramp, parameter ID1081, selection 18).

Table 205: Selections for parameter ID1089

Selection number	Selection name	Description
0	Coasting, follower remains in control even if master has stopped at fault	
1	Ramping, follower remains in control even if master has stopped at fault	
2	As master; follower behaves as master	

1090 RESET ENCODER COUNTER 6 (2.2.7.29)

Use this parameter to select the digital input signal that resets the monitoring values Shaft Angle and Shaft Rounds to zero.

See *Table 44 Monitoring values, NXS drives*.

The parameter is available for NXP drives only.

1092 MASTER FOLLOWER MODE 26 (2.2.7.31)

Use this parameter to select the digital input signal that activates the second Master Follower mode.

Select the digital input to activate the second Master Follower mode selected by parameter ID1093. The parameter is available for NXP drives only.

1093 MASTER FOLLOWER MODE 2 SELECTION 6 (2.11.7)

Use this parameter to select the Master Follower function.

Select Master Follower mode 2 that is used when the DI is activated. When Follower is selected the Run Request command is monitored from Master and all other references are selectable by parameters.

Table 206: Selections for parameter ID1093

Selection number	Selection name	Description
0	Single Drive	
1	Master	
2	Follower	

1209 INPUT SWITCH ACKNOWLEDGEMENT 6 (2.2.7.32)

Use this parameter to select the digital input signal that acknowledges the status of the input switch.

The input switch is normally a switch fuse unit or main contactor with which the power is fed to the drive. If the input switch acknowledgement is missing, the drive trips at Input switch open fault (F64). The parameter is available for NXP drives only.

1210 EXTERNAL BRAKE ACKNOWLEDGEMENT 6 (2.2.7.24)

Use this parameter to select the digital input signal that acknowledges the status of the external brake.

Connect this digital input signal to an auxiliary contact of the mechanical brake. If the brake opening command is given, but the contact of the brake feedback signal does not close in given time, a mechanical brake fault shows (fault code 58). The parameter is available for NXP drives only.

1213 EMERGENCY STOP 6 (2.2.7.30)

Use this parameter to select the digital input signal that activates the emergency stop function.

Indication to the drive that the machine has been stopped by the external emergency stop circuit. Select the digital input to activate the emergency stop input to the drive. When the digital input is low the drive stops as per the parameter definition of ID1276 Emergency stop mode and indicates the warning code A63.

The parameter is available for NXP drives only.

1217 ID BIT FREE D01 6 (P2.3.1.6)

Use this parameter to select the signal that controls the digital output.

The parameter has to be set in format xxxx.yy where xxxx is the ID number of a signal and yy is the bit number. For example, the value for D0 control is 43.06. 43 is the ID number of Status Word. So the digital output is ON when bit number 06 of Status Word (ID no. 43) i.e. Run Enable is on.

1218 DC READY PULSE 6 (2.3.3.29)

Use this parameter to select the digital input signal that enables charging of the inverter drive through an input switch.

Charge DC. Used to charge the inverter drive through an input switch. When the DC link voltage is above the charging level a 2-second pulse train is generated to close the input switch. The pulse train is OFF when the input switch acknowledgement goes high. The parameter is available for NXP drives only.

1239 INCHING REFERENCE 1 6 (2.4.15)

Use this parameter to set the frequency references for the inching function.

1240 INCHING REFERENCE 2 6 (2.4.16)

Use this parameter to set the frequency references for the inching function.

The parameter is available for NXP drives only.

1241 SPEED SHARE 6 (2.11.5)

Use this parameter to set additional scaling to the frequency reference.

Defines the percentage for final speed reference from received speed reference.

1244 TORQUE REFERENCE FILTERING TIME 6 (2.10.10)

Use this parameter to set the filtering time for the torque reference.

1248 LOAD SHARE 6 (2.11.6)

Use this parameter to set additional scaling to the torque reference.

Defines the percentage for final torque reference from received torque reference.

1250 FLUX REFERENCE 6 (2.6.23.32)

Use this parameter to set scaling to the magnetising current of the motor.

1252 SPEED STEP 6 (2.6.15.1, 2.6.25.25)

Use this parameter to adjust the speed controller when NCDrive is used.

See closer NCDrive Tools: Step response. With this tool you can give a step value to speed reference after ramp control.

1253 TORQUE STEP 6 (2.6.25.26)

Use this parameter to adjust the torque controller when NCDrive is used.

See closer NCDrive Tools: Step response. With this tool you can give step to torque reference.

1257 INCHING RAMP 6 (2.4.17)

Use this parameter to set the ramp time when inching is active.

The parameter is available for NXP drives only.

1276 EMERGENCY STOP MODE 6 (2.4.18)

Use this parameter to select how the drive stops when the emergency stop command is given from DI or Fieldbus.

Defines the action after the IO emergency input goes low. The parameter is available for NXP drives only.

Table 207: Selections for parameter ID1276

Selection number	Selection name	Description
0	Coasting stop	
1	Ramping stop	

1278 TORQUE SPEED LIMIT, CLOSED LOOP 6 (2.10.6)

Use this parameter to select the output frequency limit mode for the torque control.

Table 208: Selections for parameter ID1278

Selection number	Selection name	Description
0	Closed Loop speed control	
1	Positive and negative frequency limit	
2	Ramp generator output (-/+)	
3	Negative frequency limit - Ramp generator output	
4	Ramp generator output - Positive frequency limit	
5	Ramp generator output with window	
6	0 - Ramp generator output	
7	Ramp generator output with window and On/Off limits	

For the selection of this parameter in NXS drives, see ID644.

1285 POSITIVE FREQUENCY LIMIT 6 (2.6.20)

Use this parameter to set the final frequency reference limit for the positive direction. Maximum frequency limit for the drive. The parameter is available for NXP drives only.

1286 NEGATIVE FREQUENCY LIMIT 6 (2.6.19)

Use this parameter to set the final frequency reference limit for the negative direction. Minimum frequency limit for the drive. The parameter is available for NXP drives only.

1287 MOTORING TORQUE LIMIT 6 (2.6.22)

Use this parameter to set the maximum torque limit of the motoring side.

The parameter is available for NXP drives only.

1288 GENERATOR TORQUE LIMIT 6 (2.6.21)

Use this parameter to set the maximum torque limit of the generating side.

The parameter is available for NXP drives only.

1289 MOTORING POWER LIMIT 6 (2.6.23.20)

Use this parameter to set the maximum power limit of the motoring side.

For Closed Loop control mode only.

1290 GENERATOR POWER LIMIT 6 (2.6.23.19)

Use this parameter to set the maximum power limit of the generating side.

For Closed Loop control mode only.

1316 BRAKE FAULT RESPONSE 6 (2.7.28)

Use this parameter to set the response type to a brake fault.

Table 209: Selections for parameter ID1316

Selection number	Selection name	Description
0	No response	
1	Warning	
2	Fault, stop mode after fault according to ID506	
3	Fault, stop mode after fault always by coasting	

1317 BRAKE FAULT DELAYS 6 (2.7.29)

Use this parameter to set the delay after which the brake fault is activated when there is a mechanical delay in the brake.

See parameter ID1210.

1324 MASTER/FOLLOWER SELECTION 6 (2.11.1)

Use this parameter to select the Master/Follower mode.

When the value Follower is selected the Run Request command is monitored from Master. All other references are selectable by parameters.

Table 210: Selections for parameter ID1324

Selection number	Selection name	Description
0	Single Drive	
1	Master	
2	Follower	

1352 SYSTEMBUS FAULT DELAY 6 (2.7.31)

Use this parameter to set the maximum time for which the heartbeat is missing before a SystemBus fault occurs.

1355 TO 1369 FLUX 10-150% 6 (2.6.25.1 - 2.6.25.15)

Use this parameter to set the level of flux as a percentage of the nominal flux voltage.

Motor voltage corresponding to 10%-150% of flux as a percentage of nominal flux voltage.

1385 ID BIT FREE D02 6 (P2.3.2.6)

Use this parameter to select the signal that controls the digital output.

The parameter has to be set in format xxxx.yy where xxxx is the ID number of a signal and yy is the bit number. For example, the value for DO control is 43.06. 43 is the ID number of Status Word. So the digital output is ON when bit number 06 of Status Word (ID no. 43) i.e. Run Enable is on.

1401 STOP STATE FLUX 6 (2.6.23.24)

Use this parameter to set the flux that is kept in the motor after the AC drive stops.

The flux is maintained for the time set by parameter ID1402. This parameter can be used in closed loop motor control mode only.

1402 FLUX OFF DELAY 6 (2.6.23.23)

Use this parameter to set the time for how long the Stop State Flux is kept in the motor after the AC drive stops.

The flux defined by parameter ID1401 is maintained in the motor for the set time after the drive is stopped. This function is used to shorten the time before the full motor torque is available.

Table 211: Selections for parameter ID1402

Selection number	Selection name	Description
0	No flux after the motor is stopped.	
>0	The flux off delay in seconds.	
<0	The flux is maintained in the motor after stop until the next Run request is given to the drive.	

1412 TORQUE STABILIZER GAIN 6 (2.6.26.1)

Use this parameter to set the gain of the torque stabilator in an open loop control operation.

Additional gain for the torque stabilizer at zero frequency.

1413 TORQUE STABILATOR DAMPING 6 (2.6.26.2)

Use this parameter to set the damping time constant of the torque stabiliser.

The greater the parameter value, the shorter the time constant.

If a PMS motor is used in Open Loop control mode it is recommended to use value 980 in this parameter instead of 1000.

1414 TORQUE STABILATOR GAIN IN FIELDWEAKENING POINT 6 (2.6.26.3)

Use this parameter to set the gain of the torque stabilator at field weakening point in an open loop control operation.

1424 RESTART DELAY 6 (2.6.17)

Use this parameter to set the time delay during which the drive cannot be restarted after coast stop (flying start not in use).

The time can be set up to 60.000 seconds. The Closed Loop control mode uses a different delay.

**NOTE!**

This function is not available when flying start is selected for start function (ID505). The parameter is available for NXP drives only.

1516 MODULATOR TYPE 6 (2.4.20)

Use this parameter to select the modulator type.

Some operations require use of a software modulator.

Selection number	Selection name	Description
0	ASIC modulator	A classical third harmonic injection. The spectrum is slightly better compared to the Software 1 modulator. NOTE! An ASIC modulator cannot be used when using DriveSynch or PMS motor with an incremental type encoder.
1	Software Modulator 1	Symmetric vector modulator with symmetrical zero vectors. Current distortion is less than with software modulator 2 if boosting is used. NOTE! Recommended for DriveSynch (Set by default when DS activated) and needed when using PMS motor with an incremental encoder.

1536 FOLLOWER FAULT 6 (2.11.8)

Use this parameter to select the response of the Master drive to a fault in any of the follower drives.

For diagnostic purposes, when one of the drives trips to fault the master drive will send a command to trigger Data Logger in all the drives.

Table 212: Selections for parameter ID1536

Selection number	Selection name	Description
0	No response	
1	Warning	
2	Fault, stop mode after fault according to Stop function	

1550 FLUX CIRCLE STABILATOR GAIN 6 (2.6.26.5)

Use this parameter to set the gain for the flux circle stabilizer.

Gain for flux circle stabilizer (0-32766)

1551 FLUX STABILATOR TC 6 (2.6.26.6)

Use this parameter to set the filter coefficient of the identification current stabilizer.

1552 VOLTAGE STABILATOR TC 6 (2.6.26.11)

Use this parameter to set the damping rate of the voltage stabilizer.

Damping rate of voltage stabilizer, (0-1000).

1553 VOLTAGE STABILATOR LIMIT 6 (P2.6.26.11)

Use this parameter to set the limits for the voltage stabilizer output.

This parameter sets the limits for the voltage stabilizer output i.e. the max. and the min. value for the correction term df in FreqScale.

1566 POLARITY PULSE CURRENT 6 (P2.6.24.5)

Use this parameter to set the current level for the polarity direction check of the magnet axis during the start angle identification.

Value 0 means that the internal current level is used, which is typically slightly higher than the normal identification current defined by P2.6.24.4. Polarity direction check is seldom needed because the identification itself gives already the right direction. Hence in most cases, this function can be disabled by setting any negative parameter value, which is recommended especially if there occurs F1 faults during the identification.

1587 INV DELAYED DO1 6 (P2.3.1.5)

Use this parameter to invert the delayed digital output signal.

Inverts delayed digital output signal 1.

1588 INV DELAYED DO2 6 (P2.3.2.5)

Use this parameter to invert the delayed digital output signal.

Inverts delayed digital output signal 2.

1691 START ANGLE ID MODIFIED 6 (P2.6.24.3)

Use this parameter to select the start angle identification when no absolute encoder or incremental encoder with zpulse are used.

Identification for the start angle, i.e. the rotor magnet axis position in respect to the stator U-phase magnet axis, is needed if no absolute encoder or incremental encoder with zpulse are used. This function defines how the start angle identification is made in those cases. The identification time depends on the motor electrical characteristics but takes typically 50 ms-200 ms.

In case of absolute encoders, the start angle reads the angle value directly from the encoder. On the other hand, incremental encoder z-pulse is used automatically for synchronization if its position is defined different from zero in P2.6.24.2. Also for absolute encoders, P2.6.24.2 must be different from zero, otherwise it is interpreted that the encoder identification run has not been done and the running will be prohibited except if the absolute channel is bypassed by the start angle identification.

**NOTE!**

ModulatorType (P2.4.20) needs to be > 0 to be able to use this function.

Table 213: Selections for parameter ID1691

Selection number	Selection name	Description
0	Automatic	Decision to use start angle identification is made automatically based on the encoder type connected to the drive. This will serve common cases. Supports: OPT-A4, OPT-A5, OPT-A7 and OPT-AE boards.
1	Forced	Bypasses the drive automatic logic and forces the start angle identification to be active. Can be used, for example, with absolute encoders to bypass absolute channel information and to use start angle identification instead.
2	On Power UP	As a default, start angle identification will be repeated in every start if the identification is active. This setting will enable identification only in a first start after drive is powered up. In consecutive starts, angle will be updated based on the encoder pulse count.
10	Disabled	Used when Z- pulse from encoder is used for start angle identification.

1693 I/F CURRENT 6 (P2.6.24.6)

Use this parameter to define the current level that is used when I/f control for PMS motors is enabled.

I/f Current parameter is used for several different purposes.

I/F CONTROL

This parameter defines the current level during I/f control, in percent of the motor nominal current

ZERO POSITION WITH INCREMENTAL ENCODER AND Z-PULSE

In closed loop control utilizing the encoder z-pulse, this parameter defines also the current level used in starting before the z-pulse is received to synchronize with.

DC START ANGELE IDENTIFICATION

This parameter defines the DC Current level when Start Angle Identification Time is set greater than zero. See P2.8.5.5 Start Angle Identification Time.

1720 TORQUE STABILATOR LIMIT RATIO 6 (2.6.26.4)

Use this parameter to set a limit to the torque stabilator output.

ID111 * ID1720 = Torque Stabilator Limit

1738 VOLTAGE STABILATOR GAIN 6 (2.6.26.9)

Use this parameter to set the gain of the voltage stabilizer.

1756 START ANGLE ID CURRENT 6 (P2.6.24.4)

Use this parameter to set the current level that is used in the start angle identification.

The correct level depends of the motor type used. In general, 50% of motor nominal current seems to be sufficient, but depending for example on the motor saturation level, higher current might be needed.

1790 I/F CONTROL LIMIT 6 (P2.6.24.7)

Use this parameter to set the frequency limit for the I/f control.

This parameter sets the frequency limit for I/f-control in per cent of the motor nominal frequency. I/f-control is used if the frequency is below this limit. The operation changes back to normal when the frequency is above this limit with 1 Hz hysteresis.

1796 FLUX STABILATOR COEFFICIENT 6 (2.6.26.8)

Use this parameter to set the coefficient of the flux stabilizer for induction motors.

1797 FLUX STABILATOR GAIN 6 (2.6.26.7)

Use this parameter to set the gain of the flux stabilizer for induction motors.

1801 FB FAULT PRESET FREQUENCY 6 (P2.7.40)

Use this parameter to set the frequency reference for the fieldbus communication warning.

This parameter represents the frequency reference value to be used when fieldbus is the active control place, if fieldbus fault is active and the response to the fault (param. ID733) is set to 4/Warn:PresetF.

This parameter is present in NXP drives only.

1900 RAMP; SKIP S2 6 (P2.4.21)

Use this parameter to bypass the second corner S ramp.

This function is used to bypass the second corner S ramp (i.e. to avoid the unnecessary speed increase, shown with the solid line in *Fig. 92 Ramp; Skip S2*) when the reference is changed before the final speed is reached. Also S4 is bypassed when reference is increased while speed is ramping down.

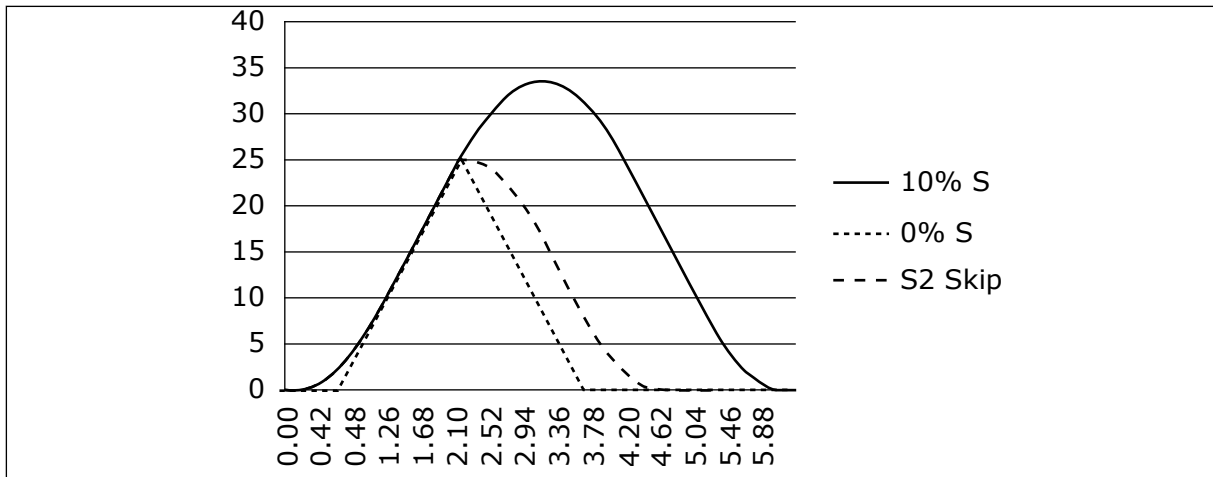

Fig. 92: Ramp; Skip S2

Second S curve is bypassed when reference changes at 25 Hz.

9.1 KEYPAD CONTROL PARAMETERS

Unlike the parameters listed above, these parameters are located in the M3 menu of the control keypad. The frequency and torque reference parameters do not have an ID number.

114 STOP BUTTON ACTIVATED (3.4, 3.6)

Use this parameter to enable the keypad stop button.

If you wish to make the Stop button a "hotspot" which always stops the drive regardless of the selected control place, give this parameter the value 1.

See also parameter ID125.

125 CONTROL PLACE (3.1)

Use this parameter to select the control place.

The active control place can be changed with this parameter. For more information, see the product's User Manual.

Pushing the Start button for 3 seconds selects the control keypad as the active control place and copies the Run status information (Run/Stop, direction and reference).

Table 214: Selections for parameter ID125

Selection number	Selection name	Description
0	PC Control, Activated by NCDrive	
1	I/O terminal	
2	Keypad	
3	Fieldbus	

123 KEYPAD DIRECTION (3.3)

Use this parameter to set the rotation direction of the motor when the control place is keypad.

Table 215: Selections for parameter ID123

Selection number	Selection name	Description
0	Forward	The rotation of the motor is forward, when the keypad is the active control place.
1	Reverse	The rotation of the motor is reversed, when the keypad is the active control place.

For more information, see the product's User Manual.

R3.2 KEYPAD REFERENCE (3.2)

The frequency reference can be adjusted from the keypad with this parameter.

The output frequency can be copied as the keypad reference by pushing the Stop button for 3 seconds when you are on any of the pages of menu M3. For more information, see the product's User Manual.

167 PID REFERENCE 1 57 (3.4)

Use this parameter to set the reference value of the PID controller.

The PID controller keypad reference can be set between 0% and 100%. This reference value is the active PID reference if parameter ID332 = 2.

168 PID REFERENCE 2 57 (3.5)

Use this parameter to set the reference value of the PID controller.

The PID controller keypad reference 2 can be set between 0% and 100%. This reference is active if the DIN5 function = 13 and the DIN5 contact is closed.

R3.5 TORQUE REFERENCE 6 (3.5)

Define here the torque reference within -300.0...300.0%.

9.2 MASTER/FOLLOWER FUNCTION (NXP ONLY)

The Master/Follower function is designed for applications in which the system is run by several NXP drives and the motor shafts are coupled to each other via gearing, chain, belt etc. It is recommended that the Closed Loop control mode be used.

The external Start/Stop control signals are connected to the Master drive only. Speed and torque references and control modes are selected for each drive separately. The Master controls the Follower(s) via a SystemBus. The Master station is typically speed-controlled and the other drives follow its torque or speed reference.

Torque control of the Follower should be used when the motor shafts of the Master and Follower drives are solidly coupled to each other by gearing, a chain etc., so that no speed difference between the drives is possible. Window control is recommended to keep the speed of the follower close to that of the master.

Speed control of the Follower should be used when the demand of speed accuracy is lower. In such cases, use of load drooping is recommended in all drives to balance the load.

9.2.1 MASTER/FOLLOWER LINK PHYSICAL CONNECTIONS

In figures below, the master drive is located on the left side and all others are followers. The master/follower physical link can be built with OPTD2 option board. See VACON® NX I/O Boards User Manual for further information.

9.2.2 OPTICAL FIBRE CONNECTION BETWEEN AC DRIVES WITH OPTD2

The OPTD2 board in the Master has the default jumper selections, i.e. X6:1-2, X5:1-2. For the followers, the jumper positions have to be changed: X6:1-2, X5:2-3. This board also has a CAN communication option that is useful for multiple drive monitoring with NCDrive PC software, when commissioning Master Follower functions or line systems.

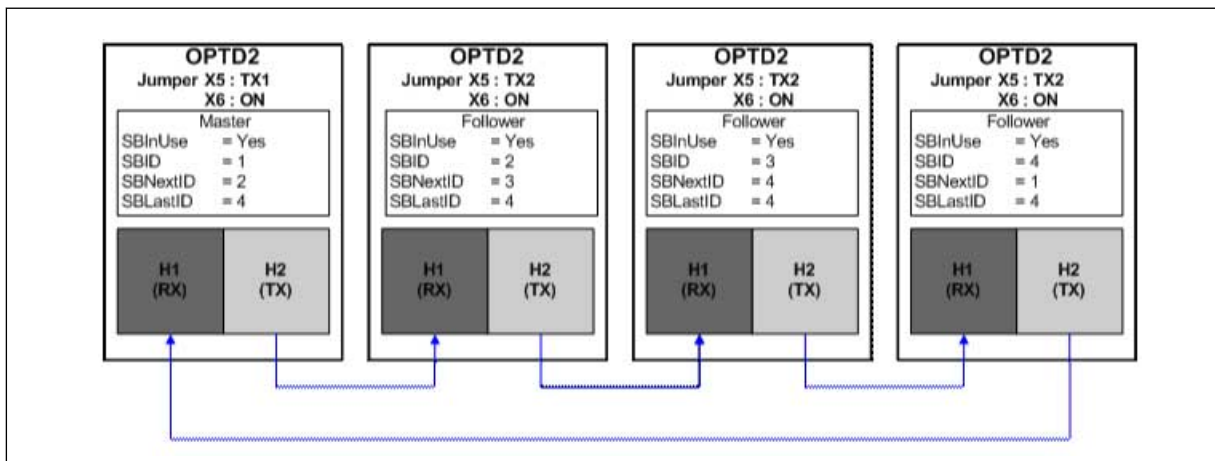

Fig. 93: System bus physical connections with the OPTD2 board

For information on the OPTD2 expander board parameters, see VACON® NX I/O Boards User Manual.

9.3 EXTERNAL BRAKE CONTROL WITH ADDITIONAL LIMITS (IDS 315, 316, 346 TO 349, 352, 353)

The external brake used for additional braking can be controlled through parameters ID315, ID316, ID346 to ID349 and ID352/ID353. Selecting On/Off Control for the brake, defining the frequency or torque limit(s) the brake should react to and defining the Brake-On/-Off delays will allow an effective brake control.



NOTE!

During Identification Run (see parameter ID631), brake control is disabled.

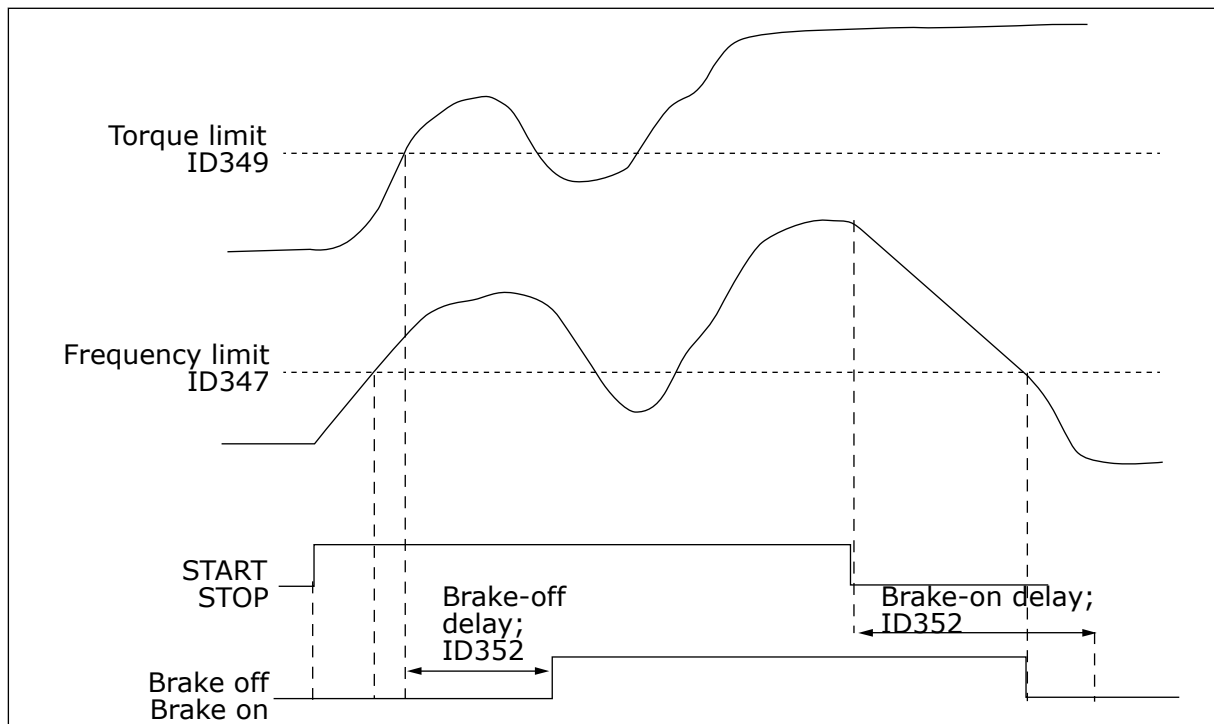

Fig. 94: Brake control with additional limits

In 21 above, the brake control is set to react to both the torque supervision limit (parameter ID349) and frequency supervision limit (ID347). Additionally, the same frequency limit is used for both brake-off and brake-on control by giving parameter ID346 the value 4. Use of two different frequency limits is also possible. Then parameters ID315 and ID346 must be given the value 3.

Brake-off: In order for the brake to release, three conditions must be fulfilled: 1) the drive must be in Run state, 2) the torque must be over the set limit (if used) and 3) the output frequency must be over the set limit (if used).

Brake-on: Stop command activates the brake delay count and the brake is closed when the output frequency falls below the set limit (ID315 or ID346). As a precaution, the brake closes when the brake-on delay expires, at the latest.



NOTE!

A fault or Stop state will close the brake immediately without a delay.

It is strongly advisable that the brake-on delay be set longer than the ramp time in order to avoid damaging of the brake.

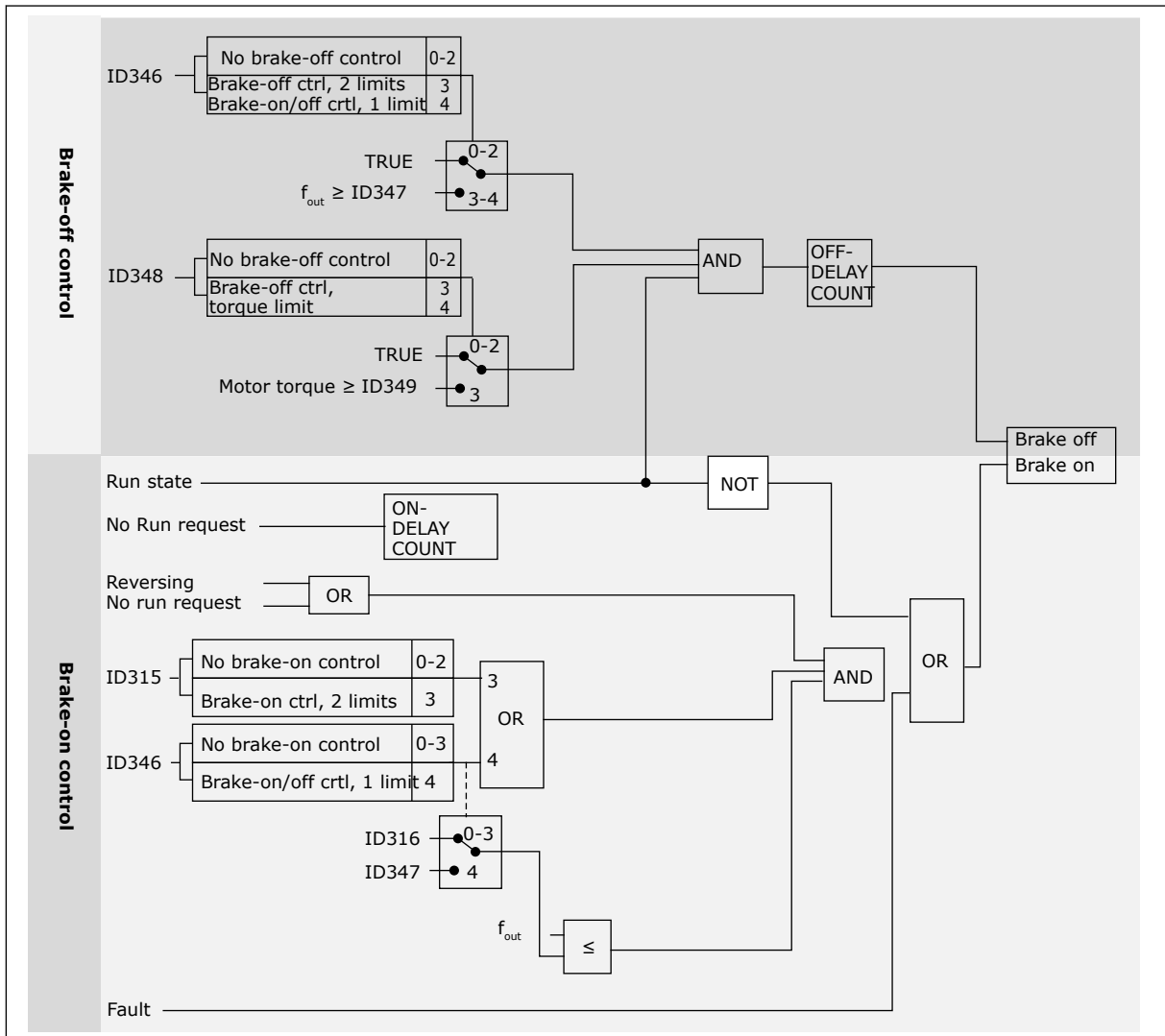

Fig. 95: Brake control logic

When using the Master Follower function, the follower drive will open the brake at the same time with the Master even if the Follower's conditions for brake opening have not been met.

9.4 PARAMETERS OF MOTOR THERMAL PROTECTION (IDS 704 TO 708)

The motor thermal protection prevents the motor from becoming too hot.

The AC drive can supply a current that is higher than the nominal current. The high current can be necessary to the load, and it must be used. In these conditions, there is a risk of a thermal overload. Low frequencies have a higher risk. At low frequencies, the cooling effect and the capacity of the motor decrease. If the motor has an external fan, the load reduction at low frequencies is small.

The motor thermal protection is based on calculations. The protection function uses the output current of the drive to know what is the load on the motor. If the control board is not energised, the calculations are reset.

The motor thermal protection can be adjusted with parameters. The thermal current IT specifies the load current above which the motor is overloaded. This current limit is a function of the output frequency.

The thermal stage of the motor can be monitored on the control keypad display. See the product's User Manual.

**NOTE!**

If you use long motor cables (max. 100 m) with small drives (≤ 1.5 kW), the motor current that the drive measures can be much higher than the actual motor current. It is because there are capacitive currents in the motor cable.

**CAUTION!**

Make sure that the airflow to the motor is not blocked. If the airflow is blocked, the function does not protect the motor, and the motor can become too hot. This can cause damage to the motor.

9.5 PARAMETERS OF STALL PROTECTION (IDS 709 TO 712)

The motor stall protection function gives protection to the motor against short overloads. An overload can be caused, for example, by a stalled shaft. It is possible to set the reaction time of the stall protection shorter than that of the motor thermal protection.

The stall status of the motor is specified with parameters ID710 (Stall current) and ID712 (Stall frequency limit). If the current is higher than the limit, and the output frequency is lower than the limit, the motor is in a stall status.

The stall protection is a type of overcurrent protection.

**NOTE!**

If you use long motor cables (max. 100 m) with small drives (≤ 1.5 kW), the motor current that the drive measures can be much higher than the actual motor current. It is because there are capacitive currents in the motor cable.

9.6 PARAMETERS OF UNDERLOAD PROTECTION (IDS 713 TO 716)

The motor underload protection makes sure that there is a load on the motor when the drive operates. If the motor loses the load, a problem can occur in the process. For example, a belt can break or a pump become dry.

You can adjust the motor underload protection with parameters ID714 (Field Weakening Area Load) and ID715 (Zero Frequency Load). The underload curve is a squared curve between the zero frequency and the field weakening point. The protection is not active below 5 Hz. The underload time counter does not operate below 5 Hz.

The values of the underload protection parameters are set in percentage of the nominal torque of the motor. To find the scaling ratio for the internal torque value, use the data in the name plate data of the motor, the motor nominal current and the nominal current of the drive IH. If you use another current than the nominal motor current, the precision of the calculation decreases.

**NOTE!**

If you use long motor cables (max. 100 m) with small drives (≤ 1.5 kW), the motor current that the drive measures can be much higher than the actual motor current. It is because there are capacitive currents in the motor cable.

9.7 FIELDBUS CONTROL PARAMETERS (IDS 850 TO 859)

The Fieldbus control parameters are used when the frequency or the speed reference comes from the fieldbus (Modbus, Profibus, DeviceNet etc.). With the Fieldbus Data Out Selection 1-8 you can monitor values from the fieldbus.

9.7.1 PROCESS DATA OUT (SLAVE -> MASTER)

The fieldbus master can read the AC drive's actual values using process data variables. Basic, Standard, Local/Remote, Multi-Step, PID control and Pump and fan control applications use process data as follows:

Table 216: The default values for Process Data Out in fieldbus

Data	Default value	Unit	Scale	ID
Process Data Out 1	Output frequency	Hz	0.01 Hz	1
Process Data Out 2	Motor speed	rpm	1 rpm	2
Process Data Out 3	Motor current	A	0.1 A	45
Process Data Out 4	Motor torque	%	0.1%	4
Process Data Out 5	Motor power	%	0.1%	5
Process Data Out 6	Motor voltage	V	0.1 V	6
Process Data Out 7	DC link voltage	V	1 V	7
Process Data Out 8	Active fault code	-	-	37

The Multipurpose application has a selector parameter for every Process Data. The monitoring values and drive parameters can be selected using the ID number. Default selections are as in the table above.

9.7.2 CURRENT SCALING IN DIFFERENT SIZE OF UNITS

**NOTE!**

Monitoring value ID45 (usually in Process data OUT3) is given with one decimal only.

Table 217: Current scaling in different size of units

Voltage	Size	Scale
208 - 240 Vac	NX_2 0001 - 0011	100 - 0.01A
208 - 240 Vac	NX_2 0012 - 0420	10 - 0.1A
380 - 500 Vac	NX_5 0003 - 0007	100 - 0.01A
380 - 500 Vac	NX_5 0009 - 0300	10 - 0.1A
380 - 500 Vac	NX_5 0385 -	1 - 1A
525 - 690 Vac	NX_6 0004 - 0013	100 - 0.01A
252 - 690 Vac	NX_6 0018 -	10 - 0.1A

9.7.3 PROCESS DATA IN (MASTER -> SLAVE)

ControlWord, Reference and Process Data are used in All in One applications as follows:

Table 218: Basic, Standard, Local/Remote, Multi-Step applications

Data	Value	Unit	Scale
Reference	Speed reference	%	0.01%
ControlWord	Start/Stop command Fault reset command	-	-
PD1 - PD8	Not used	-	-



NOTE!

Settings in the table below are factory defaults. See also parameter group G2.9.

Table 219: Multipurpose control application

Data	Value	Unit	Scale
Reference	Speed reference	%	0.01%
ControlWord	Start/Stop command Fault reset command	-	-
Process Data IN1	Torque reference	%	0.1%
Process Data IN2	Free analogue input	%	0.01%
Process Data IN3	Adjust input	%	0.01%
PD3 – PD8	Not used	-	-

Table 220: PID control and Pump and fan control applications

Data	Value	Unit	Scale
Reference	Speed reference	%	0.01%
ControlWord	Start/Stop command Fault reset command	-	-
Process Data IN1	Reference for PID controller	%	0.01%
Process Data IN2	Actual value 1 to PID controller	%	0.01%
Process Data IN3	Actual value 2 to PID controller	%	0.01%
PD4 – PD8	Not used	-	-

9.8 CLOSED LOOP PARAMETERS (IDS 612 TO 621)

Select the Closed loop control mode by setting value 3 or 4 for parameter ID600.

Closed loop control mode (see Chapter *600 Motor control mode 234567 (2.6.1)*) is used when enhanced performance near zero speed and better static speed accuracy with higher speeds are needed. Closed loop control mode is based on "rotor flux oriented current vector control". With this controlling principle, the phase currents are divided into a torque producing current portion and a magnetizing current portion. Thus, the squirrel cage induction machine can be controlled in a fashion of a separately excited DC motor.

**NOTE!**

These parameters can be used with VACON® NXP drive only.

EXAMPLE:

Motor Control Mode = 3 (Closed loop speed control)

This is the usual operation mode when fast response times, high accuracy or controlled run at zero frequencies are needed. Encoder board should be connected to slot C of the control unit. Set the encoder P/R-parameter (P7.3.1.1). Run in open loop and check the encoder speed and direction (V7.3.2.2). Switch the encoder wiring or the phases of motor cables if necessary. Do not run if encoder speed is wrong. Program the no-load current to parameter ID612 or perform the ID run without load on motor shaft and set parameter ID619 (Slip Adjust) to get the voltage slightly above the linear U/f-curve with the motor frequency at about 66% of the nominal motor frequency. The Motor Nominal Speed parameter (ID112) is critical. The Current Limit parameter (ID107) controls the available torque linearly in relative to motor nominal current.

9.9 "TERMINAL TO FUNCTION" (TTF) PROGRAMMING PRINCIPLE

The programming principle of the input and output signals in the Multipurpose Control Application as well as in the Pump and Fan Control Application (and partly in the other applications) is different compared to the conventional method used in other VACON® NX applications.

In the conventional programming method, Function to Terminal Programming Method (FTT), you have a fixed input or output that you define a certain function for. The applications mentioned above, however, use the Terminal to Function Programming method (TTF) in which the programming process is carried out the other way round: Functions appear as parameters which the operator defines a certain input/output for. See Warning in Chapter 9.9.2 *Defining a terminal for a certain function with NCDrive programming tool.*

9.9.1 DEFINING AN INPUT/OUTPUT FOR A CERTAIN FUNCTION ON KEYPAD

Connecting a certain input or output with a certain function (parameter) is done by giving the parameter an appropriate value. The value is formed of the Board slot on the VACON® NX control board (see the product's User Manual) and the respective signal number, see below.

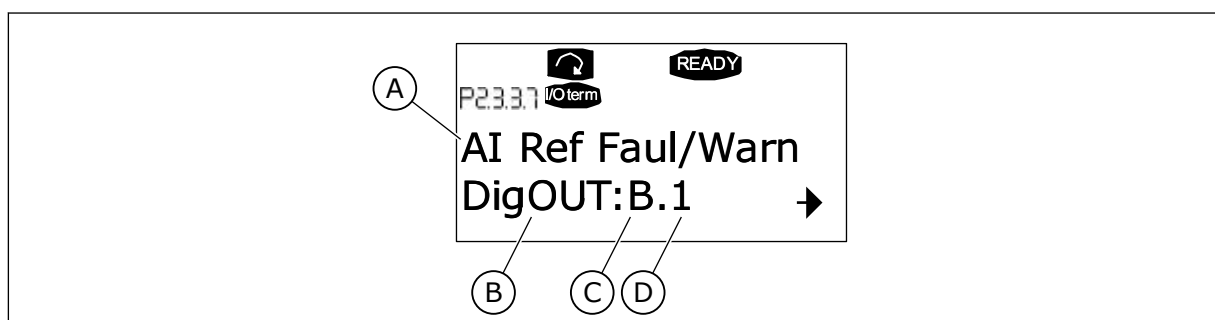

Fig. 96: Defining an input/output for a certain function on keypad

- | | |
|------------------|--------------------|
| A. Function name | C. Slot |
| B. Terminal type | D. Terminal number |

EXAMPLE

You want to connect the digital output function Reference fault/warning (parameter 2.3.3.7) to the digital output DO1 on the basic board OPTA1 (see the product's User Manual).

- 1 Find the parameter 2.3.3.7 on the keypad. Press the Menu button right once to enter the edit mode. On the value line, you will see the terminal type on the left (DigIN, DigOUT, An.IN, An.OUT) and on the right, the present input/output the function is connected to (B.3, A.2 etc.), or if not connected, a value (0.#).

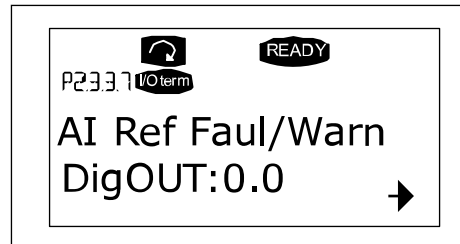

- 2 When the value is blinking, hold down the Browser button up or down to find the desired board slot and signal number. The program will scroll the board slots starting from 0 and proceeding from A to E and the I/O selection from 1 to 10.

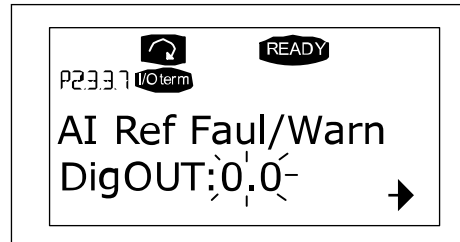

- 3 Once you have set the desired value, press the Enter button once to confirm the change.

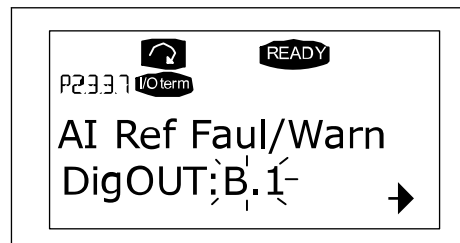

9.9.2 DEFINING A TERMINAL FOR A CERTAIN FUNCTION WITH NCDRIVE PROGRAMMING TOOL

If you use the NCDrive Programming Tool for parametrizing you will have to establish the connection between the function and input/output in the same way as with the control panel. Just pick the address code from the drop-down menu in the Value column.

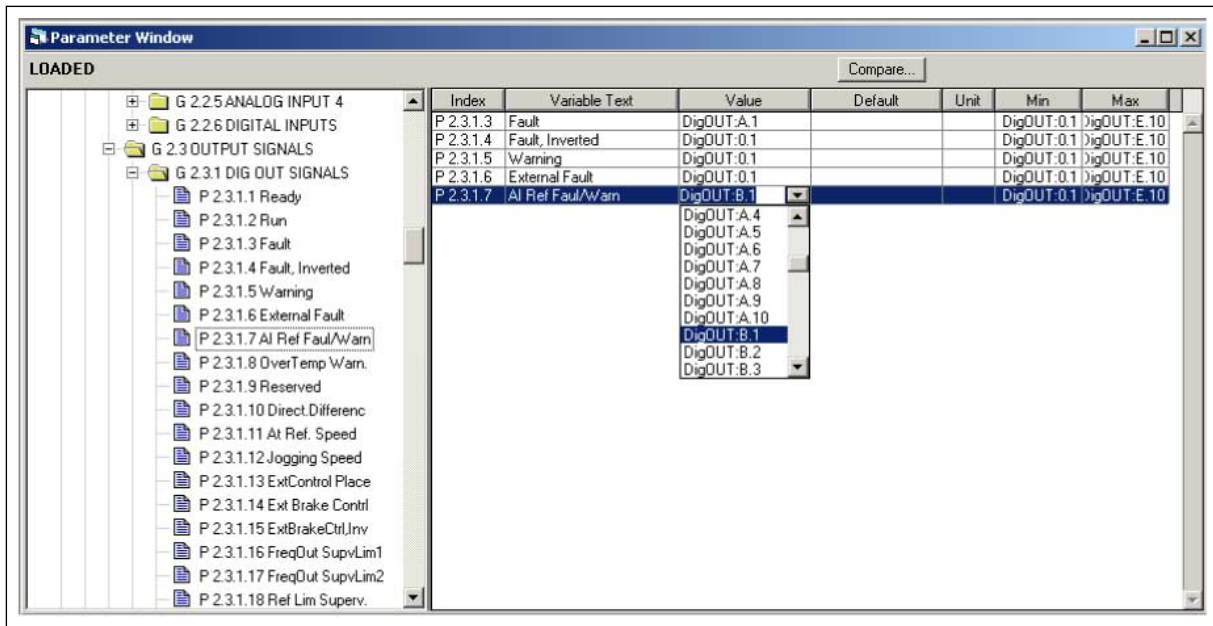

Fig. 97: Screenshot of NCDrive programming tool; Entering the address code



CAUTION!

Be ABSOLUTELY sure not to connect two functions to one and same output in order to avoid function overruns and to ensure flawless operation.



NOTE!

The inputs, unlike the outputs, cannot be changed in RUN state.

9.9.3 DEFINING UNUSED INPUTS/OUTPUTS

All unused inputs and outputs must be given the board slot value 0 and the value 1 also for the terminal number. The value 0.1 is also the default value for most of the functions. However, if you want to use the values of a digital input signal for e.g. testing purposes only, you can set the board slot value to 0 and the terminal number to any number between 2-10 to place the input to a TRUE state. In other words, the value 1 corresponds to 'open contact' and values 2 to 10 to 'closed contact'.

In case of analogue inputs, giving the value 1 for the terminal number corresponds to 0% signal level, value 2 corresponds to 20%, value 3 to 30% and so on. Giving value 10 for the terminal number corresponds to 100% signal level.

9.10 SPEED CONTROL PARAMETERS (APPLICATION 6 ONLY)

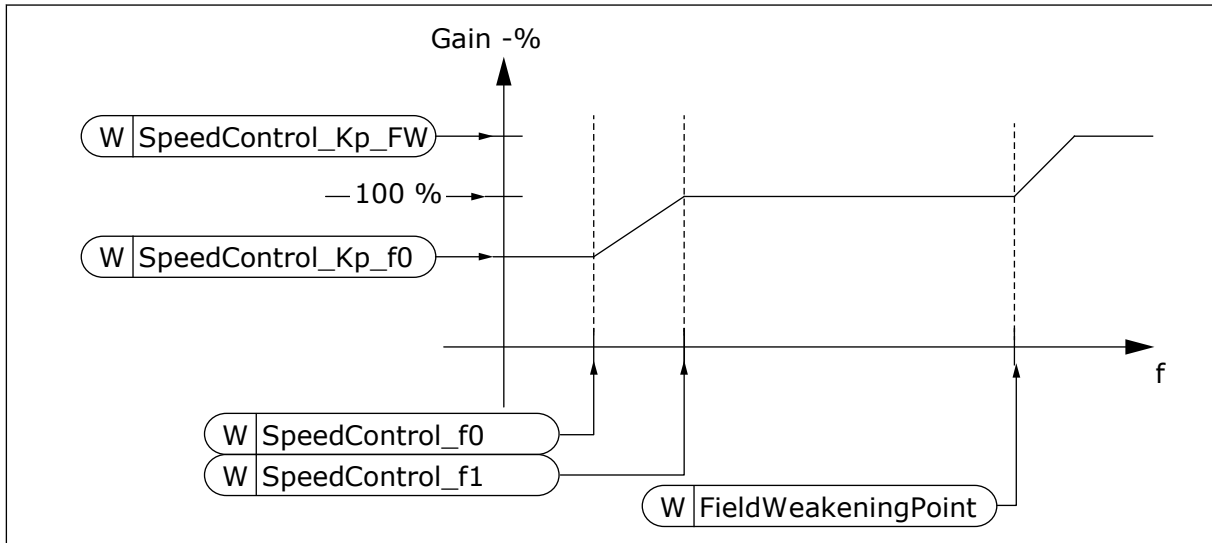

Fig. 98: Speed Controller adaptive gain

1295 SPEED CONTROLLER TORQUE MINIMUM GAIN 6 (2.6.23.30)

Use this parameter to set the relative gain in percentage when the torque is below SPC Torq Min.

The relative gain as a percentage of ID613 of the speed controller when the torque reference or the speed control output is less than the value of parameter ID1296. This parameter is normally used to stabilise the speed controller for a drive system with gear backlash.

1296 SPEED CONTROLLER TORQUE MINIMUM 6 (2.6.23.29)

Use this parameter to set the limit for the reduced speed controller gain.

The level of torque reference below which the speed controller gain is changed from ID613 to ID1295. This is in percentage of motor nominal torque. The change is filtered according to parameter ID1297.

1297 SPEED CONTROLLER TORQUE MINIMUM FILTERING TIME 6 (2.6.23.31)

Use this parameter to set the filtering time for speed controller gain.

Filtering time for torque when the speed controller gain is changed between ID613 and ID1295 depending on ID1296.

1298 SPEED CONTROLLER GAIN IN FIELD WEAKENING AREA 6 (2.6.23.28)

Use this parameter to set the final gain for speed controller gain at field weakening point.

The relative gain of the speed controller in the field weakening area as a percentage of parameter ID613.

1299 SPEED CONTROLLER GAIN F0 6 (2.6.23.27)

Use this parameter to set the relative gain in percentage below the speed controller F0 point.

The relative gain of the speed controller as a percentage of parameter ID613 when the speed is below the level defined by ID1300.

1300 SPEED CONTROLLER F0 POINT 6 (2.6.23.26)

Use this parameter to set the speed level below which the speed controller gain is equal to speed controller gain F0.

The speed level in Hz below which the speed controller gain is equal to parameter ID1299.

1301 SPEED CONTROLLER F1 POINT 6 (2.6.23.25)

Use this parameter to set the speed level above which the speed controller gain is equal to Speed control P gain.

The speed level in Hz above which the speed controller gain is equal to parameter ID613. From the speed defined by parameter ID1300 to speed defined by parameter ID1301, the speed controller gain changes linearly from parameters ID1299 to ID613 and vice versa.

1304 WINDOW POSITIVE 6 (2.10.12)

Use this parameter to set the size of the window to the positive direction from the final speed reference.

1305 WINDOW NEGATIVE 6 (2.10.11)

Use this parameter to set the size of the window to the negative direction from the final speed reference.

1306 WINDOW POSITIVE OFF LIMIT 6 (2.10.14)

Use this parameter to set the positive off limit to the speed controller when the speed comes back to the window.

1307 WINDOW NEGATIVE OFF LIMIT 6 (2.10.13)

Use this parameter to set the negative off limit to the speed controller when the speed comes back to the window.

1311 SPEED ERROR FILTER TC 6 (2.6.23.33)

Use this parameter to set the filtering time for the speed reference and the actual speed error.

Can be used to remove small disturbances in the encoder signal.

1382 SPEED CONTROL OUTPUT LIMIT 6 (2.10.15)

Use this parameter to set a maximum torque limit for the speed controller output as a percentage of the motor nominal torque.

9.11 FUNCTIONAL SAFETY PARAMETERS (APPLICATION 6 ONLY)

542 RESPONSE TO SAFE STOP REQUEST 6 (P2.12.1)

Use this parameter to set the action of the drive when a Safe Stop request becomes active on the safety option board.

With this setting, you can select if:

- the drive is allowed to ramp down the speed of the motor or
- the upper control system responsible to ramp down the speed of the motor.

Table 221: Selections for parameter ID542

Selection number	Selection name	Description
0	No action	The drive does not react to the safe stop requests. Upper control system is responsible to ramp down the speed of the drive.
1	Stop, according to ramp 1	Stop the drive by ramping. Deceleration ramp according to parameter P2.1.4 Decel Time 1.
2	Stop, according to ramp 2	Stop the drive by ramping. Deceleration ramp according to parameter P2.4.4 Decel Time 2.
3	Stop, according to ramp configured to the safety option board	Stop the drive by ramping. The drive uses a deceleration ramp which is an average value of min and max ramp times which are configured on the safety option board.

543 RESPONSE TO SAFE LIMITED SPEED (SLS) REQUEST 6 (P2.12.2)

Use this parameter to set the action of the drive when a SLS request becomes active on the safety option board.

With this setting, you can select if:

- the drive is allowed to limit and decelerate the speed of the motor
- the upper control system responsible to limit and decelerate the speed of the motor.

Table 222: Selections for parameter ID542

Selection number	Selection name	Description
0	No action	The drive does not react to the SLS requests. Upper control system is responsible to limit and decelerate the speed of the drive.
1	Limit the speed reference, decelerate according to ramp 1	The speed reference of the drive is limited to the value that is 95% of the requested SLS speed limit. Deceleration ramp according to parameter P2.1.4 Decel Time 1.
2	Limit the speed reference, decelerate according to ramp 2	The speed reference of the drive is limited to the value that is 95% of the requested SLS speed limit. Deceleration ramp according to parameter P2.4.4 Decel Time 2.
3	Limit the speed reference, decelerate according to the ramp configured to the safety option board	The speed reference of the drive is limited to the value that is 95% of the requested SLS speed limit. The drive uses deceleration ramp which is an average value of the min and max ramp times which are configured to the safety option board.

544 RESPONSE TO SAFE DIRECTION (SDI) REQUEST 6 (P2.12.3)

Use this parameter to set the action of the drive when a SDI request becomes active on the safety option board.

With this setting, you can select if:

- the drive is allowed to prohibit the speed reference on unintended direction
- the upper control system responsible prohibit speed reference on unintended direction.

Table 223: Selections for parameter ID542

Selection number	Selection name	Description
0	No action	The drive does not react to the SDI requests. Upper control system is responsible to prohibit the speed reference on unintended direction.
1	Prohibit the speed reference on unintended direction	The speed reference of the drive is prohibited on unintended direction.

9.12 AUTOMATIC CHANGING BETWEEN DRIVES (APPLICATION 7 ONLY)

The Autochange function allows the starting and stopping order of drives controlled by the pump and fan automatics to be changed at desired intervals. The drive controlled by AC drive can also be included in the automatic changing and locking sequence (P2.9.25). The Autochange function makes it possible to equalize the run times of the motors and to prevent e.g. pump stalls due to too long running breaks.

- Apply the Autochange function with parameter 2.9.24, Autochange.
- The autochange takes place when the time set with parameter 2.9.26, Autochange interval, has expired and the capacity used is below the level defined with parameter 2.9.28, Autochange frequency limit.
- The running drives are stopped and re-started according to the new order.
- External contactors controlled through the relay outputs of the AC drive connect the drives to the AC drive or to the mains. If the motor controlled by the AC drive is included in the autochange sequence, it is always controlled through the relay output activated first. The other relays activated later control the auxiliary drives (see *Fig. 100 Example of 2-pump autochange, main diagram* and *Fig. 101 Example of 3-pump autochange, main diagram*).

1027 AUTOCHANGE 7 (2.9.24)

Use this parameter to enable or disable the rotation of the start sequence and the priority of motors.

Table 224: Selections for parameter ID1027

Selection number	Selection name	Description
0	Autochange not used	
1	Autochange used	

The automatic change of starting and stopping order is activated and applied to either the auxiliary drives only or the auxiliary drives and the drive controlled by the AC drive, depending on the setting of parameter 2.9.25, Automatics selection. By default, the Autochange is activated for 2 drives. See *Fig. 19 Pump and fan control application default I/O configuration and connection example (with 2-wire transmitter)* and *Fig. 100 Example of 2-pump autochange, main diagram*.

1028 AUTOCHANGE/INTERLOCKINGS AUTOMATICS SELECTION 7 (2.9.25)

Use this parameter to select if the autochange is applied to the auxiliary drives or all drives.

Table 225: Selections for parameter ID1028

Selection number	Selection name	Description
0	Automatics (autochange/interlockings) applied to auxiliary drives only	The drive controlled by the AC drive remains the same. Therefore, mains contactor is needed for one auxiliary drive only.
1	All drives included in the autochange/interlockings sequence	The drive controlled by the AC drive is included in the auto-matics and a contactor is needed for each drive to connect it to either the mains or the AC drive.

1029 AUTOCHANGE INTERVAL 7 (2.9.26)

Use this parameter to adjust the autochange intervals.

After the expiry of the time defined with this parameter, the autochange function takes place if the capacity used lies below the level defined with parameters 2.9.28 (Autochange frequency limit) and 2.9.27 (Maximum number of auxiliary drives). Should the capacity exceed the value of P2.9.28, the autochange will not take place before the capacity goes below this limit.

- The time count is activated only if the Start/Stop request is active at control place A.
- The time count is reset after the autochange has taken place or on removal of Start request at control place A.

1030 AND 1031 MAXIMUM NUMBER OF AUXILIARY DRIVES AND AUTOCHANGE FREQUENCY LIMIT (2.9.27 AND 2.9.28)

1030: Use this parameter to set the amount of auxiliary drives used.

1031: Use this parameter to set the autochange frequency limit.

These parameters define the level below which the capacity used must remain so that the autochange can take place.

This level is defined as follows:

- If the number of running auxiliary drives is smaller than the value of parameter 2.9.27 the autochange function can take place.
- If the number of running auxiliary drives is equal to the value of parameter 2.9.27 and the frequency of the controlled drive is below the value of parameter 2.9.28 the autochange can take place.
- If the value of parameter 2.9.28 is 0.0 Hz, the autochange can take place only in rest position (Stop and Sleep) regardless of the value of parameter 2.9.27.

9.13 INTERLOCK SELECTION (P2.9.23)

This parameter is used to activate the interlock inputs. The interlocking signals come from the motor switches. The signals (functions) are connected to digital inputs which are programmed as interlock inputs using the corresponding parameters. The pump and fan control automatics only control the motors with active interlock data.

- The interlock data can be used even when the Autochange function is not activated
- If the interlock of an auxiliary drive is inactivated and another unused auxiliary drive available, the latter will be put to use without stopping the AC drive.
- If the interlock of the controlled drive is inactivated, all motors will be stopped and restarted with the new set-up.
- If the interlock is re-activated in Run status, the automatics functions according to parameter 2.9.23, Interlock selection:

Table 226: Selections for Interlock selection

Selection number	Selection name	Description
0	Not used	
1	Update in stop	<p>Interlocks are used. The new drive will be placed last in the autochange line without stopping the system. However, if the autochange order now becomes, for example, [P1 -> P3 -> P4 -> P2], it will be updated in the next Stop (autochange, sleep, stop, etc.).</p> <p>EXAMPLE:</p> <p>[P1 -> P3 -> P4] -> [P2 LOCKED] -> [P1 -> P3 -> P4 -> P2] -> [SLEEP] -> [P1 -> P2 -> P3 -> P4]</p>
2	Stop & Update	<p>Interlockings are used. The automatics will stop all motors immediately and re-start with a new set-up.</p> <p>EXAMPLE:</p> <p>[P1 -> P2 -> P4] -> [P3 LOCKED] -> [STOP] -> [P1 -> P2 -> P3 -> P4]</p>

See Chapter 9.14 Examples of Autochange and Interlock selection.

9.14 EXAMPLES OF AUTOCHANGE AND INTERLOCK SELECTION

9.14.1 PUMP AND FAN AUTOMATICS WITH INTERLOCKS AND NO AUTOCHANGE

Situation:

- One controlled drive and three auxiliary drives.
- Parameter settings: 2.9.1=3, 2.9.25=0
- Interlock feedback signals used, autochange not used.
- Parameter settings: 2.9.23=1, 2.9.24=0
- The interlock feedback signals come from the digital inputs selected with parameters 2.2.6.18 to 2.2.6.21.
- The Auxiliary drive 1 control (P2.3.1.27) is enabled through Interlock 1 (P2.2.6.18), the Auxiliary drive 2 control (P2.3.1.28) through Interlock 2 (P2.2.6.19) etc.

Phases:

1. The system and the motor controlled by the AC drive are started.
2. The Auxiliary drive 1 starts when the main drive reaches the starting frequency set (P2.9.2).
3. The main drive decreases speed down to Auxiliary drive 1 Stop frequency (P2.9.3) and starts to rise toward the Start frequency of Auxiliary drive 2, if needed.
4. The Auxiliary drive 2 starts when the main drive has reached the starting frequency set (P2.9.4).
5. The Interlock feedback is removed from Aux. drive 2. Because the Aux. drive 3 is unused, it will be started to replace the removed Aux. drive 2.
6. The main drive increases speed to maximum because no more auxiliary drives are available.
7. The removed Aux.drive 2 is reconnected and placed last in the auxiliary drive start order which now is 1-3-2. The main drive decreases speed to the set Stop frequency. The auxiliary drive start order will be updated either immediately or in the next Stop (autochange, sleep, stop, etc.) according to P2.9.23.
8. If still more power is needed, the main drive speed rises up to the maximum frequency placing 100% of the output power in the system's disposal.

When the need of power decreases, the auxiliary drives turn off in the opposite order (2-3-1; after the update 3-2-1).

9.14.2 PUMP AND FAN AUTOMATICS WITH INTERLOCKS AND AUTOCHANGE

The above is also applicable if the autochange function is used. In addition to the changed and updated start order, also the change order of main drives depends on parameter 2.9.23.

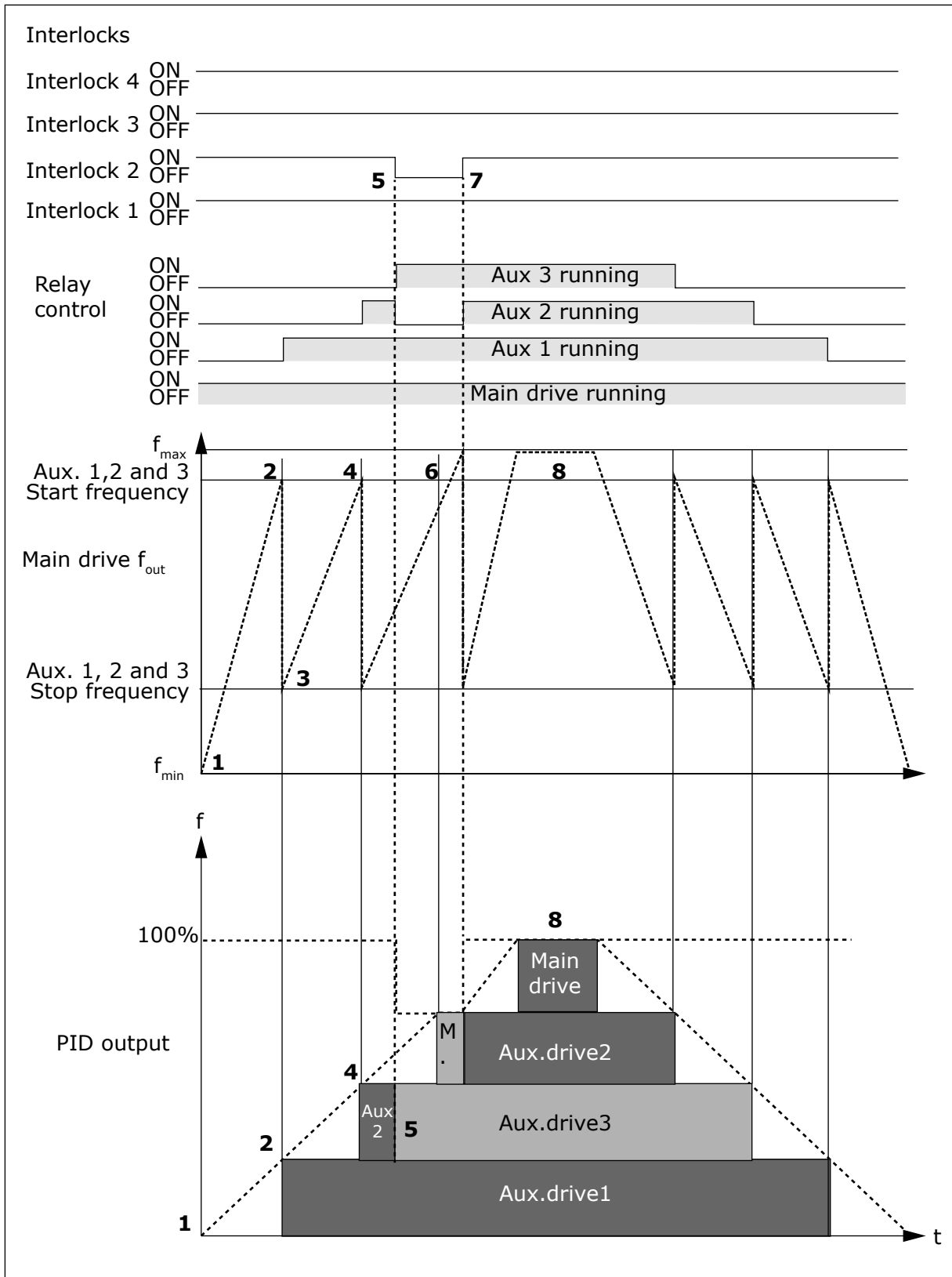

Fig. 99: Example of the function of the PFC application with three aux. drives

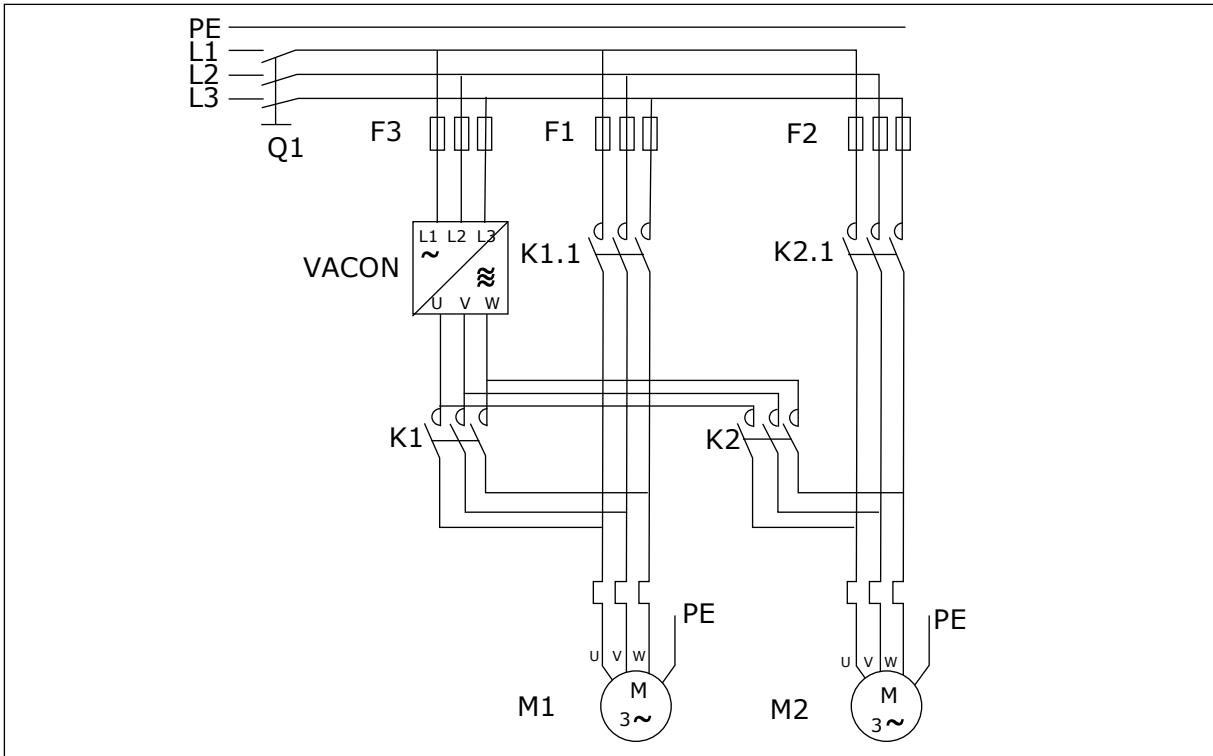

Fig. 100: Example of 2-pump autochange, main diagram

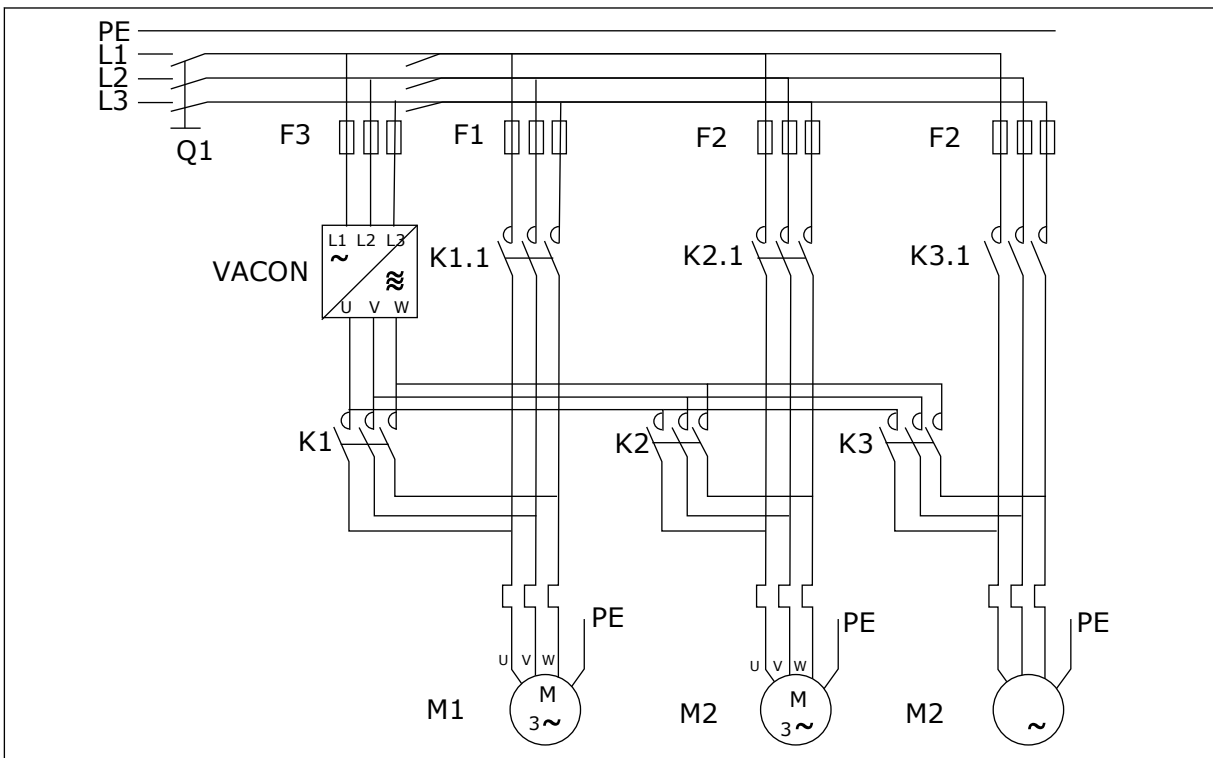

Fig. 101: Example of 3-pump autochange, main diagram

9.15 FIELD BUS CONTROL IN DETAIL

Combina- tion	P7.x.1.4 Operate Mode (Fieldbus option board)	P2.9.35 Fieldbus State Machine	Note
1	ProfiDrive	Standard	See fieldbus option board manual. Control Word and Status Word are explained there.
2	ByPass	ProfiDrive	See chapter 9.15.1 <i>Combination 2: ByPass - ProfiDrive</i> .
3	ByPass	Standard	See chapter 9.15.2 <i>Combination 3: ByPass - Standard</i> .
4	ProfiDrive	ProfiDrive	Drive cannot be operated from fieldbus when this combination is activated.

9.15.1 COMBINATION 2: BYPASS - PROFIDRIVE

Table 227: Control Word (ProfiDrive)

	Signal	Description
b0	ON	0>1 resets the Switch On Inhibit state and bring the drive to Ready Run. Always reset after fault, Coast Stop (b1) and Quick Stop (b2)
b1	Coast Stop	0=Coast stop Active 1=Coast stop NOT active
b2	Quick Stop	0=Coast stop Active 1=Coast stop NOT active
b3	Start	Normal start command 0=Stop the drive 1=Start the drive
b4	Ramp Output to Zero	0=Force speed ramp output to zero 1=Release speed ramp output
b5	Ramp Hold	0=Hold speed ramp output 1=Release speed ramp
b6	Ramp Input to Zero	0=Force speed ramp input to zero 1=Release speed ramp input
b7	Fault Reset	0=No Action 1=Reset active faults
b8	Inching 1	Run the drive with defined constant speed 0=No Action 1=Run with constant speed
b9	Inching 2	Run the drive with defined constant speed 0=No Action 1=Run with constant speed
b10	Fieldbus Control Enable	Activate Fieldbus control when P3.1 =3/Fieldbus 0=Fieldbus Control NOT active 1=Activate Fieldbus Control
b11	FB DIN 1	
b12	FB DIN 2	
b13	FB DIN 3	
b14	FB DIN 4	
b15	Reserved	Reserved for internal use

Table 228: Status Word (ProfiDrive)

	Signal	Description
b0	Ready To Switch On	0=The drive NOT ready to switch ON 1=The drive is ready to switch ON
b1	Ready To Operate	0=The drive is NOT ready to run 1=The drive is ready to run
b2	Operation Enabled	0=The drive is NOT running 1=The drive is running and ready to release the reference
b3	Fault Active	0=No fault active 1=Fault IS active
b4	Coast Stop Not Active	0=Coast stop active 1=Coast stop NOT active
b5	Quick Stop Not Active	0=Emergency stop active 1=Emergency stop NOT active
b6	Switch On Inhibited	0=No Inhibit 1=The drive is out of fault and coast / quick stop state
b7	Warning	0=NO alarm 1=Alarm IS active
b8	Speed At Reference	0=Speed actual is NOT equal to speed reference 1=Speed actual is equal to speed reference
b9	Fieldbus Control Active	0=Fieldbus Control NOT active 1=Fieldbus Control active
b10	Speed Reference Reached or Exceeded	Indicate if speed actual is below the limit P2.4.16 0=Speed actual is below the speed limit 1=Speed actual is above the speed limit
b11	Not Used	Reserved
b12	Drive Running	0=Drive is stopped 1=Drive is running
b13	Drive Ready	0=Drive is not ready 1=Drive is ready
b14	Not Used	Reserved
b15	Not Used	Reserved

9.15.2 COMBINATION 3: BYPASS - STANDARD

Table 229: Control Word (Standard)

	Signal	Description
b0	Start/Stop	0=Stop the drive 1=Start the drive
b1	Direction	0=Clockwise 1=Counter clockwise
b2	Fault Reset	0=No Action 1=Reset active faults
b3	FB DIN 1	
b4	FB DIN 2	
b5	FB DIN 3	
b6	FB DIN 4	
b7	FB DIN 5	
b8	No action	
b9	No action	
b10	No action	
b11	No action	
b12	No action	
b13	No action	
b14	No action	
b15	Reserved	Reserved for internal use

Table 230: Status Word (Standard)

	Signal	Description
b0	Ready To Switch On	0=The drive NOT ready to switch ON 1=The drive is ready to switch ON
b1	Ready To Operate	0=The drive is NOT ready to run 1=The drive is ready to run
b2	Operation Enabled	0=The drive is NOT running 1=The drive is running and ready to release the reference
b3	Fault Active	0=No fault active 1=Fault IS active
b4	Coast Stop Not Active	0=Coast stop active 1=Coast stop NOT active
b5	Quick Stop Not Active	0=Emergency stop active 1=Emergency stop NOT active
b6	Switch On Inhibited	0=No Inhibit 1=The drive is out of fault and coast / quick stop state
b7	Warning	0=NO alarm 1=Alarm IS active
b8	Speed At Reference	0=Speed actual is NOT equal to speed reference 1=Speed actual is equal to speed reference
b9	Fieldbus Control Active	0=Fieldbus Control NOT active 1=Fieldbus Control active
b10	Speed Reference Reached or Exceeded	Indicate if speed actual is below the limit P2.4.16 0=Speed actual is below the speed limit 1=Speed actual is above the speed limit
b11	Not Used	Reserved
b12	Drive Running	0=Drive is stopped 1=Drive is running
b13	Drive Ready	0=Drive is not ready 1=Drive is ready
b14	Not Used	Reserved
b15	Not Used	Reserved

10 FAULT TRACING

10.1 FAULT CODES

Fault code	Fault	Subcode in T.14	Possible cause	How to correct the fault
1	Overcurrent	S1 = Hardware trip	<p>There is too high a current (>4*I_H) in the motor cable. Its cause can be 1 of these.</p> <ul style="list-style-type: none"> • a sudden heavy load increase • a short circuit in the motor cables • the motor is not the correct type 	<p>Do a check of the loading. Do a check of the motor. Do a check of the cables and connections. Make an identification run.</p>
		S2 = Reserved		
		S3 = Current controller supervision		
		S4 = User configured overcurrent limit exceeded		
2	Overvoltage	S1 = Hardware trip	<p>The DC-link voltage is higher than the limits.</p> <ul style="list-style-type: none"> • too short a deceleration time • high overvoltage spikes in the supply • Start/Stop sequence too fast 	<p>Set the deceleration time longer. Use the brake chopper or the brake resistor. They are available as options. Activate the overvoltage controller. Do a check of the input voltage.</p>
		S2 = Overvoltage control supervision		
3*	Earth fault		<p>The measurement of current tells that the sum of the motor phase current is not zero.</p> <ul style="list-style-type: none"> • an insulation malfunction in the cables or the motor 	<p>Do a check of the motor cables and the motor.</p>
5	Charging switch		<p>The charging switch is open, when the START command is given.</p> <ul style="list-style-type: none"> • operation malfunction • defective component 	<p>Reset the fault and start the drive again. If the fault shows again, ask instructions from the distributor near to you.</p>
6	Emergency stop		<p>Stop signal has been given from the option board.</p>	<p>Do a check of the emergency stop circuit.</p>

Fault code	Fault	Subcode in T.14	Possible cause	How to correct the fault
7	Saturation trip		<ul style="list-style-type: none"> defective component brake resistor short-circuit or overload 	This fault cannot be reset from the control panel. Switch off the power. DO NOT RESTART THE DRIVE or CONNECT THE POWER! Ask instructions from the factory. If this fault shows at the same time with Fault 1, do a check of the motor cable and the motor.
8	System fault	S1 = Reserved S2 = Reserved S3 = Reserved S4 = Reserved S5 = Reserved S6 = Reserved S7 = Charging switch S8 = No power to driver card S9 = Power unit communication (TX) S10 = Power unit communication (Trip) S11 = Power unit comm. (Measurement)	<ul style="list-style-type: none"> operation malfunction defective component 	Reset the fault and start the drive again. If the fault shows again, ask instructions from the distributor near to you.

Fault code	Fault	Subcode in T.14	Possible cause	How to correct the fault
9 *	Undervoltage	S1 = DC-link too low during run	<p>The DC-link voltage is lower than the limits.</p> <ul style="list-style-type: none"> • too low a supply voltage • AC drive internal fault • a defective input fuse • the external charge switch is not closed 	<p>If there is a temporary supply voltage break, reset the fault and start the drive again.</p> <p>Do a check of the supply voltage. If the supply voltage is sufficient, there is an internal fault.</p> <p>Ask instructions from the distributor near to you.</p>
		S2 = No data from power unit		
		S3 = Undervoltage control supervision		
10 *	Input line supervision		The input line phase is missing.	Do a check of the supply voltage, the fuses and supply cable.
11 *	Output phase supervision		The measurement of current tells that there is no current in 1 motor phase.	Do a check of the motor cable and the motor.
12	Brake chopper supervision		There is no brake resistor. The brake resistor is broken. A defective brake chopper.	Do a check of the brake resistor and the cabling. If they are in good condition, there is a fault in the resistor or the chopper. Ask instructions from the distributor near to you.
13	Frequency converter undertemperature		Too low a temperature in the heatsink of the power unit or in the power board. The heatsink temperature is below -10 °C (14 °F).	
14	Frequency converter overtemperature		Heatsink temperature is over 90 °C (194 °F) (or 77 °C (170.6 °F), NX_6, FR6). Overtemperature alarm is issued when the heatsink temperature goes over 85 °C (185 °F) (72 °C (161.6 °F)).	Do a check of the actual amount and flow of cooling air. Examine the heatsink for dust. Do a check of the ambient temperature. Make sure that the switching frequency is not too high in relation to the ambient temperature and the motor load.
15 *	Motor stalled		The motor stalled.	Do a check of the motor and the load.
16 *	Motor overtemperature		There is too heavy a load on the motor.	Decrease the motor load. If there is no motor overload, do a check of the temperature model parameters.
17 *	Motor underload		Motor underload protection has tripped.	Do a check of the load.

Fault code	Fault	Subcode in T.14	Possible cause	How to correct the fault
18 **	Unbalance	S1 = Current unbalance	Unbalance between power modules in paralleled power units.	If the fault occurs again, ask instructions from the distributor near to you.
		S2 = DC voltage unbalance		
22	EEPROM checksum fault		Parameter save fault. <ul style="list-style-type: none"> • operation malfunction • defective component 	If the fault occurs again, ask instructions from the distributor near to you.
24 **	Counter fault		Values displayed on counters are incorrect	
25	Microprocessor watchdog fault		<ul style="list-style-type: none"> • operation malfunction • defective component 	Reset the fault and start the drive again. If the fault shows again, ask instructions from the distributor near to you.
26	Start-up prevented		Start-up of the drive has been prevented. Run request in ON when new application is downloaded to the drive.	Cancel prevention of start-up if this can be done safely. Remove Run request
29 *	Thermistor fault		The thermistor input of option board has detected increase of the motor temperature.	Do a check of the motor cooling and loading. Do a check of the thermistor connection. (If thermistor input of the option board is not in use it has to be short circuited).
30	Safe disable		The input on OPTAF board has opened,	Cancel Safe Disable if this can be done safely.
31	IGBT temperature (hardware)		IGBT Inverter Bridge over-temperature protection has detected too high a short term overload current	Do a check of the loading. Do a check of the motor size. Make an identification run.
32	Fan cooling		Cooling fan of the AC drive does not start, when ON command is give.	Ask instructions from the distributor near to you.
34	CAN bus communication		Sent message not acknowledged.	Make sure that there is another device on the bus with the same configuration.

Fault code	Fault	Subcode in T.14	Possible cause	How to correct the fault
35	Application		Problem in application software.	Ask instructions from the distributor near to you. If you are an application programmer, do a check of the application program.
36	Control unit		NXS Control Unit can not control NXP Power Unit and vice versa	Change the control unit.
37 **	Device changed (same type)		The option board was replaced by a new one that you have used before in the same slot. The parameters are available in the drive.	Reset the fault. The device is ready for use. The drive starts to use the old parameter settings.
38 **	Device added (same type)		The option board was added. You have used the same option board before in the same slot. The parameters are available in the drive.	Reset the fault. The device is ready for use. The drive starts to use the old parameter settings.
39 **	Device removed		An option board was removed from the slot.	The device is not available. Reset the fault.
40	Device unknown	S1 = Unknown device	An unknown device was connected (the power unit/option board)	Ask instructions from the distributor near to you.
		S2 = Power1not same type as Power2		
41	IGBT temperature		IGBT Inverter Bridge over-temperature protection has detected too high a short term overload current.	Do a check of the loading. Do a check of the motor size. Make an identification run.
42	Brake resistor overtemperature		Brake resistor overtemperature protection has detected too heavy braking.	Set the deceleration time longer. Use external brake resistor.

Fault code	Fault	Subcode in T.14	Possible cause	How to correct the fault
43	Encoder fault	1 = Encoder 1 channel A is missing 2 = Encoder 1 channel B is missing 3 = Both encoder 1 channels are missing 4 = Encoder reversed 5 = Encoder board missing	Problem detected in encoder signals.	Do a check of the encoder connections. Do a check of the encoder board. Do a check of the encoder frequency in the open loop.
44 **	Device changed (different type)		Option board or power unit changed. New device of different type or different power rating.	Reset. Set the option board parameters again if option board was changed. Set AC drive parameters again if power unit was changed.
45 **	Device added (different type)		Option board of different type added.	Reset. Set the power unit parameters again.
49	Division by zero in application		Division by zero has occurred in application program.	If the fault shows again while the AC drive is in run state, ask instructions from the distributor near to you. If you are an application programmer, do a check of the application program.
50 *	Analogue input lin < 4mA (sel. signal range 4 to 20 mA)		Current at the analogue input is < 4mA. control cable is broken or loose signal source has failed.	Do a check of the current loop circuitry.
51	External fault		Digital input fault.	Remove fault situation on external device.
52	Keypad communication fault		The connection between the control panel (or NCDriver) and the drive is defective.	Do a check of the control panel connection and the control panel cable.

Fault code	Fault	Subcode in T.14	Possible cause	How to correct the fault
53	Fieldbus fault		The data connection between the fieldbus master and the fieldbus board is defective.	Do a check of the installation and fieldbus master. If the installation is correct, ask instructions from the distributor near to you.
54	Slot fault		Defective option board or slot	Do a check of the board and slot. Ask instructions from the distributor near to you.
56	Over Temp.		Temperature exceeded set limit. Sensor disconnected. Short circuit.	Find the cause of temperature rise.
57 **	Identification		Identification run has failed.	Run command was removed before completion of identification run. The motor is not connected to the AC drive. There is load on motor shaft.
58 *	Brake		Actual status of the brake is different from the control signal.	Do a check of the mechanical brake state and connections.
59	Follower communication		SystemBus or CAN communication is broken between Master and Follower.	Do a check of the option board parameters. Do a check of the optical fibre cable or CAN cable.
60	Cooling		Coolant circulation on liquid-cooled drive has failed.	Do a check of the reason for the failure on the external system.
61	Speed error		Motor speed is unequal to reference.	Do a check of the encoder connection. PMS motor has exceeded the pull out torque.
62	Run disable		Run enable signal is low.	Do a check of the reason for the Run enable signal.
63 **	Emergency stop		Command for emergency stop received from digital input or fieldbus.	New run command is accepted after reset.
64 **	Input switch open		Drive input switch is open.	Do a check of the main power switch of the drive.
65	Over Temp.		Temperature exceeded set limit. Sensor disconnected. Short circuit.	Find the cause of temperature rise.
70 *	Active filter fault		Fault triggered by dig. input (see param. P2.2.7.33).	Remove fault situation on active filter

Fault code	Fault	Subcode in T.14	Possible cause	How to correct the fault
74	Follower fault		When using normal Master Follower function this fault code is given if one or more follower drives trip to fault.	

* = You can set different responses in the application for these faults. See parameter group Protections.

** = A faults (alarms) only.

VACON[®]

www.danfoss.com

Vacon Ltd
Member of the Danfoss Group
Runsorintie 7
65380 Vaasa
Finland

Document ID:



DPD00903F

Rev. F

Sales code: DOC-APPXALL+DLUK