

VACON[®] NXP
AC DRIVES

OPTBL, OPTBM, OPTBN
ADVANCED SAFETY OPTIONS
QUICK GUIDE

VACON[®]

PREFACE

DOCUMENT DETAILS

Document ID: DPD01919B

Date: 12.7.2018

ABOUT THIS MANUAL

This manual is copyright of VACON Ltd. All Rights Reserved. The manual is subject to change without prior notice. The language of the original instructions is English.

REFERENCES

You can download the VACON® NXP Advanced Safety Options Operating Guide from the Danfoss website <http://drives.danfoss.com/knowledge-center/technical-documentation/>. It is necessary to read the Operating Guide to understand and design the safety system.

The VACON® Safe tool can be downloaded from <http://drives.danfoss.com/services/pc-tools>.

The Commissioning report can be printed from the VACON® Safe tool with prefilled data. The Commissioning report can also be found as an appendix in the VACON® NXP Advanced Safety Options Operating Guide.

VERSION HISTORY

Date	Revision	Updates
23.1.2017	A	The first published version of this manual.
12.7.2018	B	<ul style="list-style-type: none"> • Information on the manual added. Chapter <i>About this manual</i>. • Version history table added. • Table linking option board names to option board codes. Chapter 2.4 <i>General information</i>. • Images edited. Chapter 2 <i>VACON® Advanced Safety Option variants</i>. • Warning added. Chapter 3.1 <i>Installation of the option board to VACON® NXP AC drive</i>. • Safety bypass procedure updated. Chapter 4.4 <i>Safety bypass</i>. • Configuration example added. Chapter 4.5 <i>Emergency stop using the STO function</i>. • Other minor updates. Throughout the manual.

TABLE OF CONTENTS

Preface

Document details	3
About this manual	3
References	3
Version history	3
1 General information	6
1.1 Requirements	6
1.2 Safety levels of the Advanced safety option board	6
1.3 Using the Advanced safety option board	6
2 VACON® Advanced Safety Option variants	8
2.1 Option board OPTBL	8
2.2 Option board OPTBM	8
2.3 Option board OPTBN	9
2.4 General information	11
3 Installation	12
3.1 Installation of the option board to VACON® NXP AC drive	12
3.1.1 The installation procedure	12
4 Commissioning	14
4.1 Preparing for commissioning	14
4.2 Parameterisation process	15
4.3 First start-up after the installation of the option board	17
4.3.1 Doing the first start-up with the option board	17
4.4 Safety bypass	18
4.5 Emergency stop using the STO function	18

1 GENERAL INFORMATION

1.1 REQUIREMENTS

Table 1: Required drive component versions

Component	Version	Comment
The control board of NXP AC drive	Hardware: VB00761 B or newer Software: NXP00002V196 or newer	
The STO and ATEX option board (OPTAF)	Hardware: VB00328 E or newer	SIL2, PLd Cat3 component

Table 2: The PC tools that can be used with the option board

PC tool	Version	Comment
NCDrive	2.0.29 or newer	You can use older versions than this, but they do not show correctly the details of safety related faults.
VACON® Loader	1.1.12.0 or newer	The tool is used to update the option board firmware.
VACON® Safe	1.0.0.0 or newer	The tool is used to parameterise and monitor the option board.

1.2 SAFETY LEVELS OF THE ADVANCED SAFETY OPTION BOARD

- Safety integrity level (SIL): SIL 3
- Performance level (PL): PL e
- Category (Cat): Cat 4

1.3 USING THE ADVANCED SAFETY OPTION BOARD

The Advanced safety option board is used to implement safety functions in accordance with the standard EN IEC-61800-5-2. The option board handles the safe I/O and the monitoring of active safety functions. The option board does not handle the control of the AC drive. The AC drive can be controlled, for example, with the drive application, or the external process control system can give the speed reference to the AC drive.

The Advanced safety option board must be used with a subsystem that provides the STO function, it is not possible to use the Advanced safety option board alone. The STO function is provided, for example, by the OPTAF STO option board. To use the safety functions that do speed monitoring, an external speed sensor is necessary. The sensor can be a digital or an analogue encoder or a digital proximity sensor.

When you use a safe fieldbus, you must install an option board that supports the fieldbus.

The Fig. 1 below shows the configuration of the AC drive with the Advanced safety option board with all possible functions. The safe fieldbus and the closed loop control are optional.

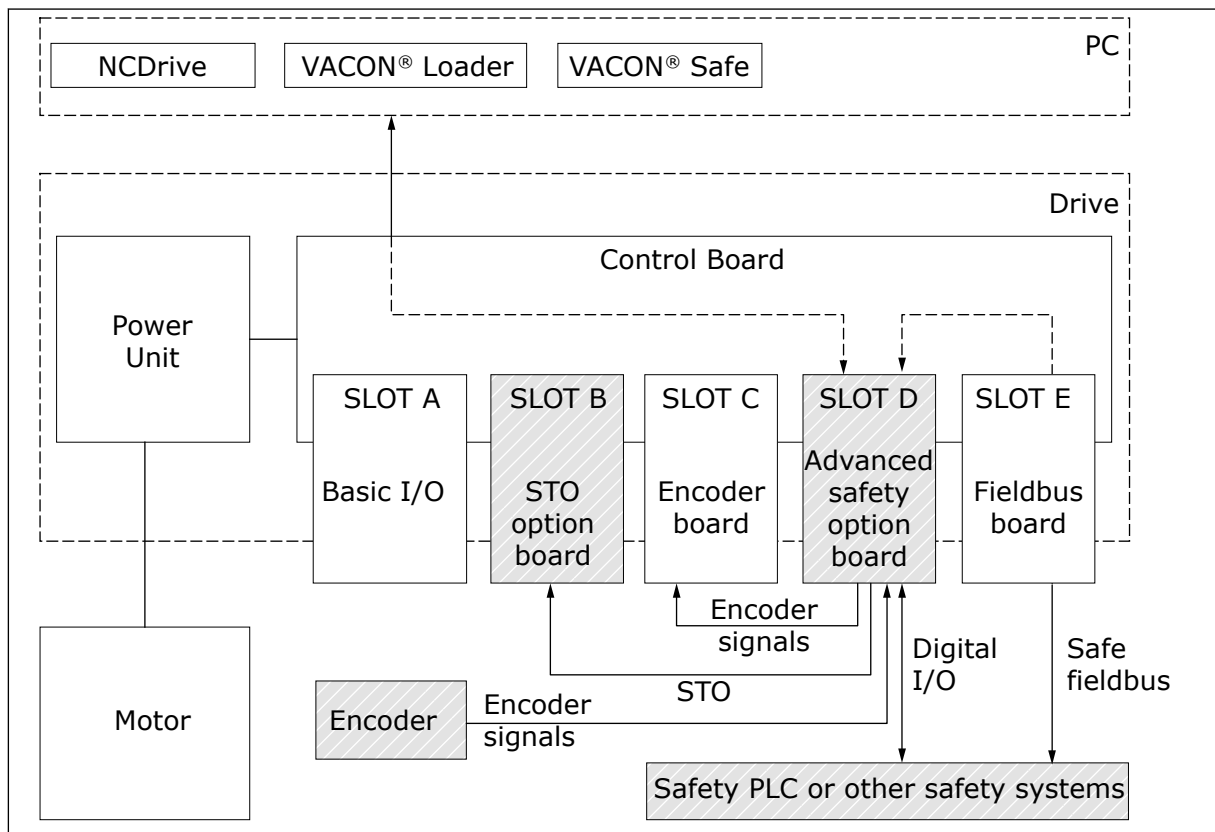

Fig. 1: An example configuration of the NXP drive with the Advanced safety option board. The sub-systems that handle safety actions are marked in grey.

2 VACON® ADVANCED SAFETY OPTION VARIANTS

2.1 OPTION BOARD OPTBL

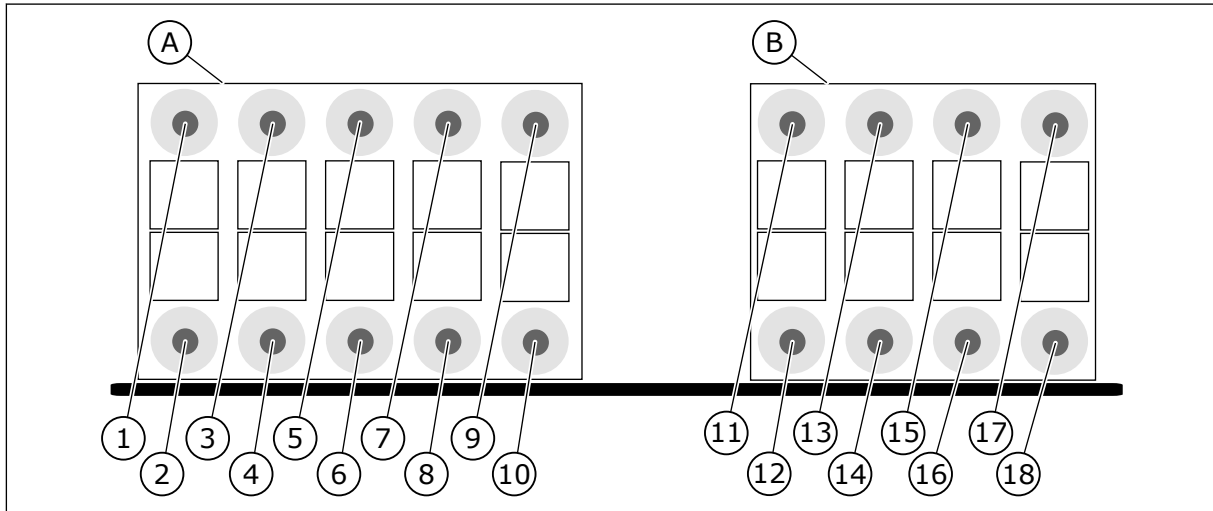

Fig. 2: The terminals of the OPTBL option board

A. Terminals X3

1. STO 1. STO terminal 1 +24 V.
2. STO 2. STO terminal 2 +24 V.
3. GND.
4. GND.
5. Dout 1A. Terminal A of digital output 1.
6. Dout 1B. Terminal B of digital output 1.
7. Dout 2A. Terminal A of digital output 2.
8. Dout 2B. Terminal B of digital output 2.
9. +24 V. +24 V supply for external logic.
10. GND.

B. Terminals X4

11. Din 1A. Terminal A of digital input 1.
12. Din 1B. Terminal B of digital input 1.
13. Din 2A. Terminal A of digital input 2.
14. Din 2B. Terminal B of digital input 2.
15. Din 3A. Terminal A of digital input 3.
16. Din 3B. Terminal B of digital input 3.
17. Din 4A. Terminal A of digital input 4.
18. Din 4B. Terminal B of digital input 4.

2.2 OPTION BOARD OPTBM

The OPTBM option board is similar to the OPTBL option board, but in addition, the OPTBM option board has a digital pulse TTL/HTL type encoder interface board attached to it.

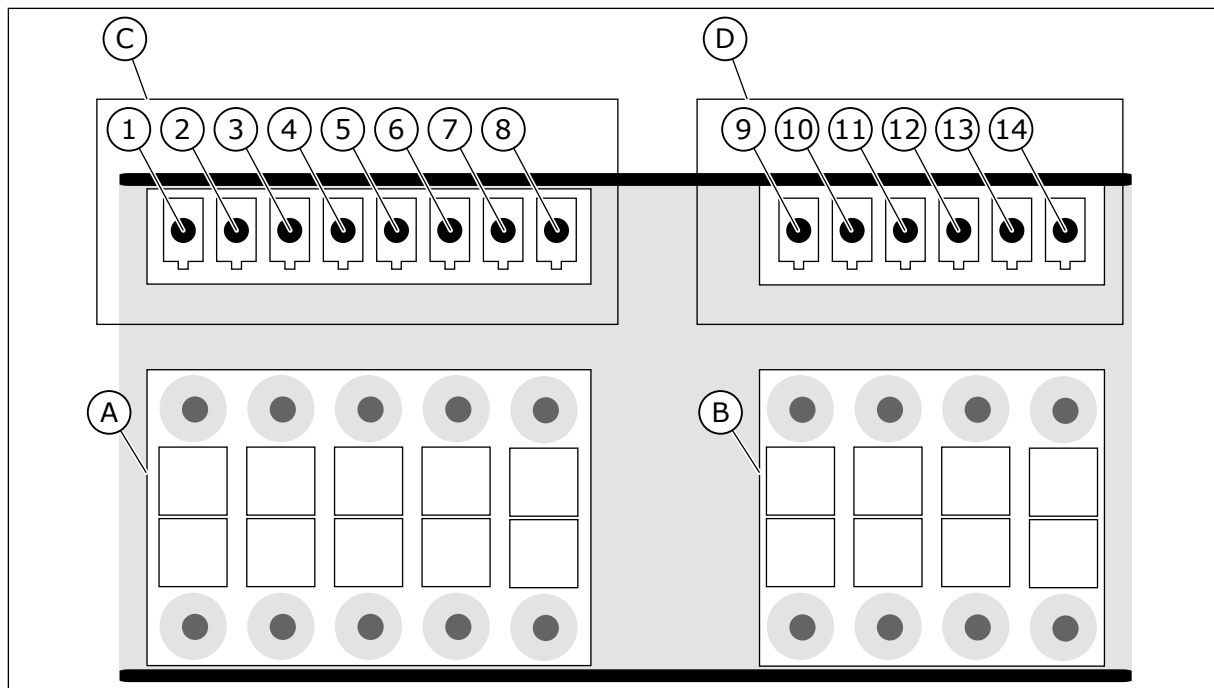

Fig. 3: The terminals of the digital pulse type encoder interface board

C. Encoder input terminals

1. Encoder voltage. Configurable encoder voltage.
2. GND.
3. A+. Terminal A of digital pulse signal.
4. A-. Terminal A of digital pulse signal.
5. B+. Terminal B of digital pulse signal.
6. B-. Terminal B of digital pulse signal.
7. Z+. Reference signal, optional.
8. Z-. Reference signal, optional.

A. Terminals X3 (See Fig. 2.)

2.3 OPTION BOARD OPTBN

The OPTBN option board is similar to the OPTBL option board, but in addition, the OPTBN option board has a Sin/Cos type encoder interface board attached to it.

D. Encoder output terminals

9. A+. Unmodified encoder signal loop-back.
10. A-. Unmodified encoder signal loop-back.
11. B+. Unmodified encoder signal loop-back.
12. B-. Unmodified encoder signal loop-back.
13. Z+. Unmodified encoder signal loop-back.
14. Z-. Unmodified encoder signal loop-back.

B. Terminals X4 (See Fig. 2.)

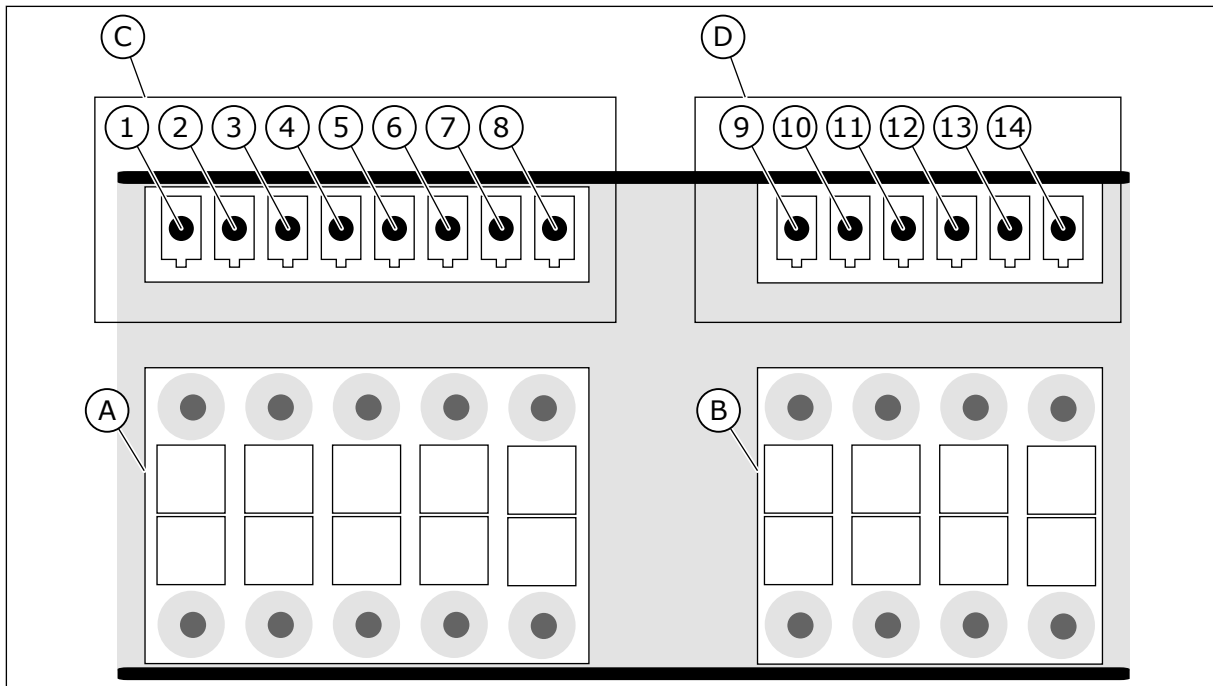

Fig. 4: The terminals of the Sin/Cos type encoder interface board

C. Encoder input terminals

1. Encoder voltage. Selectable encoder voltage.
2. GND.
3. Sin+. Sinus terminal of analogue pulse signal.
4. Sin-. Sinus terminal of analogue pulse signal.
5. Cos+. Cosine terminal of analogue pulse signal.
6. Cos-. Cosine terminal of analogue pulse signal.
7. Z+. Reference signal, optional.
8. Z-. Reference signal, optional.

A. Terminals X3 (See Fig. 2.)

D. Encoder output terminals

9. Sin+. Unmodified encoder signal loop-back.
10. Sin-. Unmodified encoder signal loop-back.
11. Cos+. Unmodified encoder signal loop-back.
12. Cos-. Unmodified encoder signal loop-back.
13. Z+. Unmodified encoder signal loop-back.
14. Z-. Unmodified encoder signal loop-back.

B. Terminals X4 (See Fig. 2.)

2.4 GENERAL INFORMATION

Option board name	Code on the sticker on the option board
OPTBL	70CVB01938
OPTBM	70CVB01957 *
OPTBN	70CVB01958 *

* = The OPTBM and OPTBN option boards also contain the sticker 70CVB01938. For these products, check the code on the the sticker that is on the encoder interface board.

3 INSTALLATION

3.1 INSTALLATION OF THE OPTION BOARD TO VACON® NXP AC DRIVE



CAUTION!

Do not install, remove, or replace option boards on the drive when the power is on. Doing this can cause damage to the boards.



WARNING!

Do not touch the control terminals. They can have a dangerous voltage also when the drive is disconnected from mains.



CAUTION!

Measure or do a check of the encoder supply voltage of the encoder interface board before you connect a new encoder. The encoder supply voltage might have been set to a higher voltage than what is supported by the new encoder. An incorrect encoder supply voltage can cause damage to the equipment.

THE INSTALLATION PROCEDURE

- 1 Remove the cable cover.

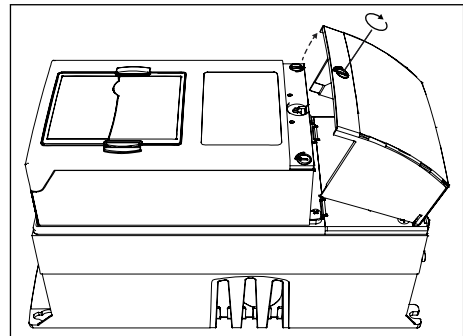

- 2 Open the cover of the control unit.

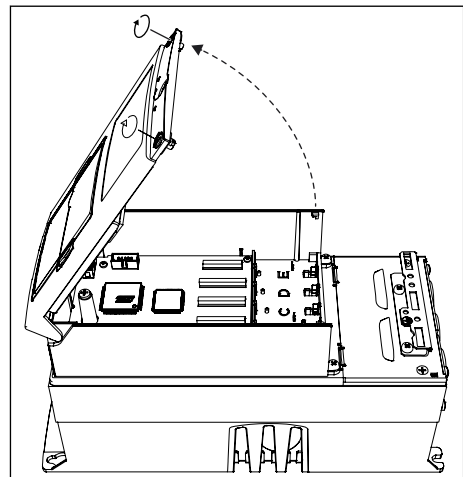

- 3 Install the option board into the **slot D** on the control board of the AC drive. Make sure that the grounding plate fits tightly in the clamp.

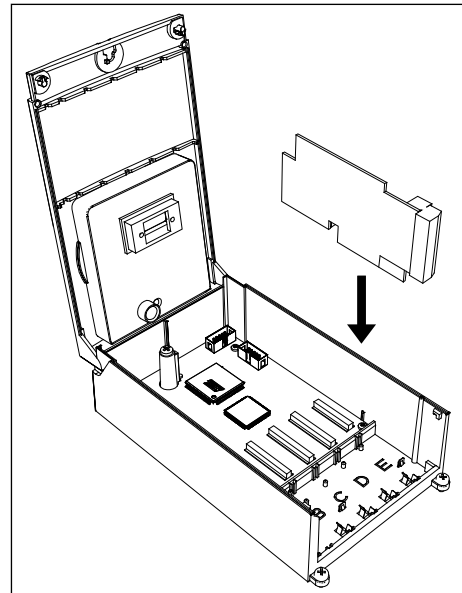

- 4 In IP21, cut free the opening on the cover of the AC drive for the used option boards.
- 5 Install the cables.
- 6 Close the cover of the control unit and put back the cable cover.

4 COMMISSIONING

4.1 PREPARING FOR COMMISSIONING

**NOTE!**

The information in this chapter is also included in the Commissioning report.

The Commissioning report lists relevant instructions for commissioning the option board. The Commissioning report can be printed from the VACON® Safe tool with prefilled data. The Commissioning report can also be found as an appendix in the VACON® NXP Advanced Safety Options Operating Guide.

If it is possible, commission the AC drive first without the Advanced safety option board to make sure that your process is operational.

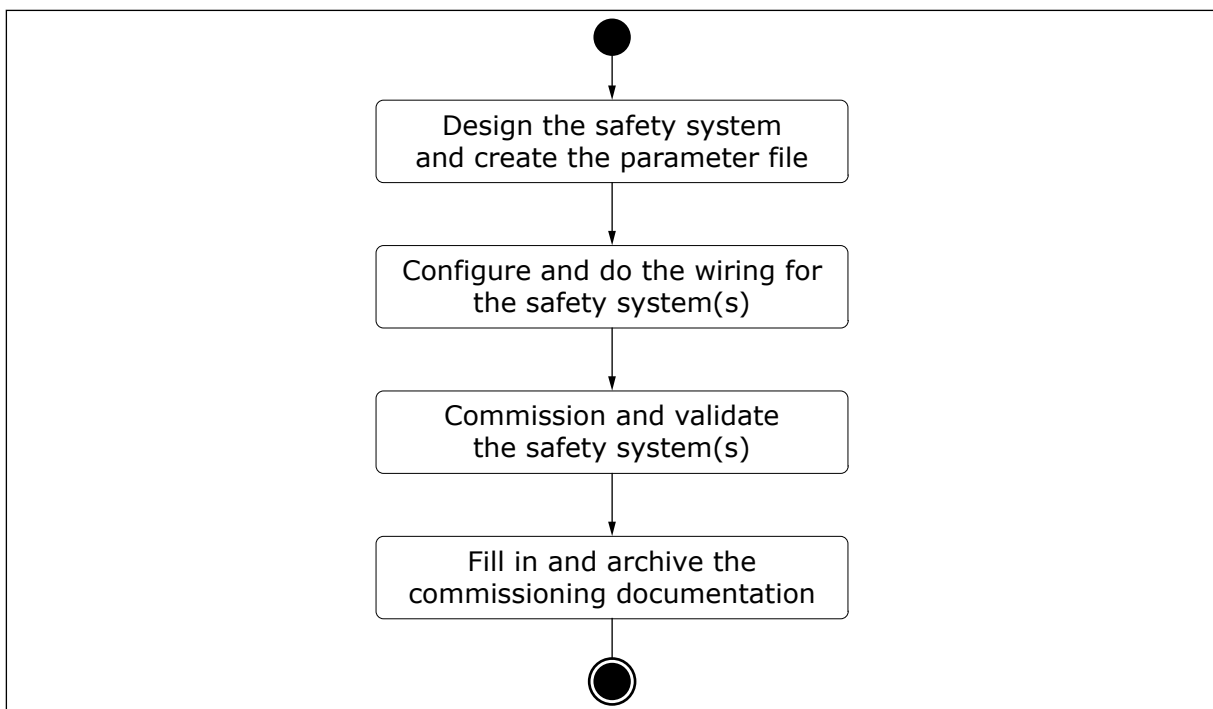

Fig. 5: Preparing and commissioning a safety system that includes the Advanced safety option board

Preparing for the commissioning before the first start-up of the system with the option board

- Read the Advanced safety options Operating Guide and the Commissioning report and apply their instructions in the commissioning plan.
- Read the User Manual of the AC drive.
- Refer to the user manuals of other subsystems connected to the commissioned drive system.
- Define the parameter file for the Advanced safety option board.
- Make sure that the hardware and configuration are correct, and that the software is correct in the components of the AC drive and its subsystems.
- Make sure that the information of the commissioned AC drive matches the information in the commissioning plan and the Commissioning report.
- Make sure that the connections between different systems have been checked and are ready to be used.
- Make sure that the area affected by the commissioned systems is free and secure for the commissioning.
- Make sure that no danger can be caused to personnel if the system has been configured incorrectly and behaves unexpectedly.
- Make sure that the AC drive is correctly parameterised and commissioned for use.
 - The motor parameters have been set.
 - The identification run has been done. Preferred identification type: identification with run or encoder ID run.
 - The fieldbus connection can be established. If a fieldbus is used.
- Have a computer available with a software to control and parameterise the AC drive and the option boards, and to store test logs and parameters.
- Have the Commissioning report available.

Document the deviations compared to expected results during the commissioning and testing procedures. Do not release the system for use if any unacceptable deviations exist.

4.2 PARAMETERISATION PROCESS

Use the VACON® Safe tool to parameterise the Advanced safety option board.

The parameterisation process of the Advanced safety option board has 4 steps.

1. Selection of safety functions ("Select functions" in the tool).
2. Editing the safety functions ("Adjust parameters" in the tool).
3. Verifying the transfer of parameters to the option board ("Verify and Approve" in the tool).
4. Validation of the parameter file ("Validate" in the tool).

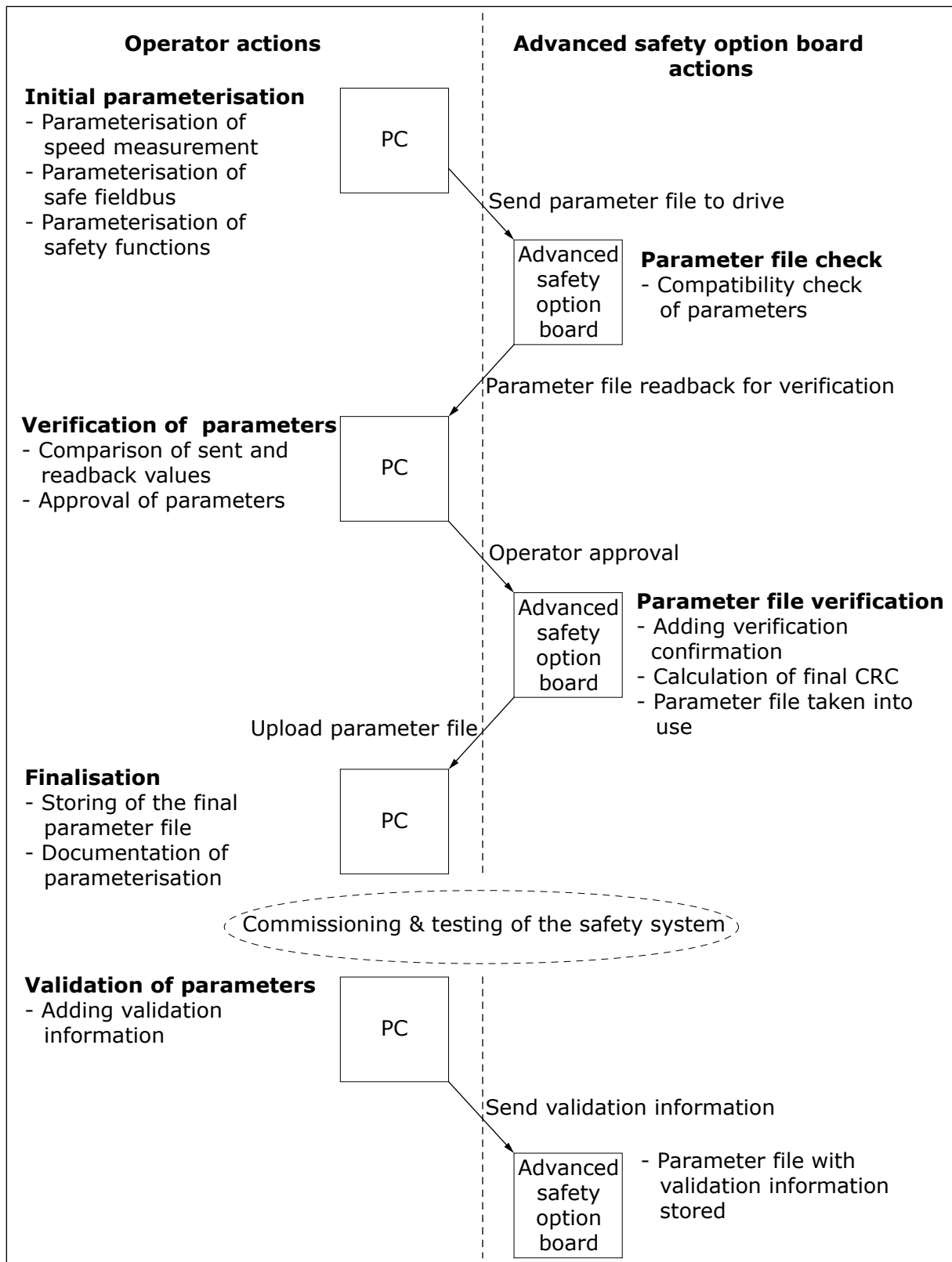

Fig. 6: The process of creating a new parameter file

4.3 FIRST START-UP AFTER THE INSTALLATION OF THE OPTION BOARD



NOTE!

The information in this chapter is also included in the Commissioning report.

After the option board is installed in the AC drive, do these steps.

DOING THE FIRST START-UP WITH THE OPTION BOARD

- 1 Do power-up on the AC drive.
 - a) The drive shows the fault F38 DeviceAdded (submodule: slot D, subcode: 1). The actual faults shown depend on the configuration used during the previous start-up if other changes have also been made.
 - b) If the option board was already installed and tested at the factory, the fault is not shown.
 - c) Other faults are also shown: the warning for Safe Torque Off (F30, subcode: 1) and the fault for Safety System (F20 SafetySystem, source: 82 - Plaus. check, fault number: 3). Fault F20 indicates that the option board has no valid parameter file.
- 2 Reset the faults.
 - a) The drive is not ready. The warning F30 SafeTorqueOff is shown.
 - b) If the option board has been used in a previous configuration, it is possible that it has a valid parameter file already. In this case, the drive may be in READY state.
 - c) The faults that are shown and their type (Fault or Alarm) depend on the settings of the AC drive.
 - d) STO state can also be seen from the STO board diagnostic relay output.
- 3 Parameterise the option board using the VACON® Safe tool.
 - a) After parameterisation the fault F20 (source: 82, fault number: 3) disappears. Depending on the parameterised safety functions and the state of the option board inputs, different safety functions can be reported as requested or reached.
 - b) The fault F20 (source: 243 - drive conf, fault number: 2) appears. The fault indicates that the parameter file is not tested and validated.

- 4 Print the prefilled Commissioning report from the VACON® Safe tool or save the report in digital form.
- 5 Test the safe fieldbus, or if a safe fieldbus is not used, the relevant safety functions.

Table 3: Commissioning check list

Step	Commissioning action	Yes	No
1	The correct installation of the option board has been verified and documented.		
2	The option board has been parameterised with the intended configuration.		

To commission the different safety functions, see Commissioning report of the option board.

4.4 SAFETY BYPASS



WARNING!

When the Advanced safety option board is bypassed, it does not provide any safety functions.

If the Advanced safety option board is installed in the AC drive with an STO board and the AC drive itself has not been commissioned, it may be preferable to bypass the safety functions of the Advanced safety option to make the commissioning simpler. To bypass the safety functions of the Advanced safety option, do these steps.

1. Disconnect the STO outputs of the Advanced safety option board if they are connected. Leave the outputs disconnected.
2. Connect the STO request input of the STO board to terminals +24 V and GND so that the STO function is disabled.
3. Do power-up to the AC drive.
4. Set the parameter P7.4.1.2.1 in the expander board menu to value "Warning" to deactivate the drive response to faults reported by the Advanced safety option.
5. Reset the faults.
 - The AC drive should be in the READY state.



NOTE!

While not strictly required, it is advisable to return the parameter P7.4.1.2.1 to its default value "Default" after the commissioning activities.

4.5 EMERGENCY STOP USING THE STO FUNCTION

A configuration for realising emergency stop according to IEC-60204-1 using the STO function in the Advanced safety option board OPTBL and the STO option board OPTAF. The drive reset is used to clear the faults and to deactivate the STO function after violations and faults. The STO function is set to the manual acknowledgement mode.

Depending on the result of the risk and hazard analysis, you can use the safe external acknowledgement signal ¹⁾ or the non-safe drive acknowledgement ²⁾. The case in *Fig. 7* has safe external acknowledgement.

The STO request is assigned to Digital Input 1 of the Advanced safety option board. External acknowledgement signal is assigned to Digital input 2. No speed measurement is needed or considered for this configuration.

Configuration in OPTBL. Used safety functions: STO

STO parameters	Value
Acknowledgement Mode (STO)	Manual

Input / output parameters	Value
Digital Input 1	STO
Digital Input 2	Acknowledgement 1)

General parameters	Value
Drive Reset	Enabled
Drive Acknowledgement	Enabled 2) Disabled 1)

¹⁾ and ²⁾ indicate alternative options. Use values marked with the same number.

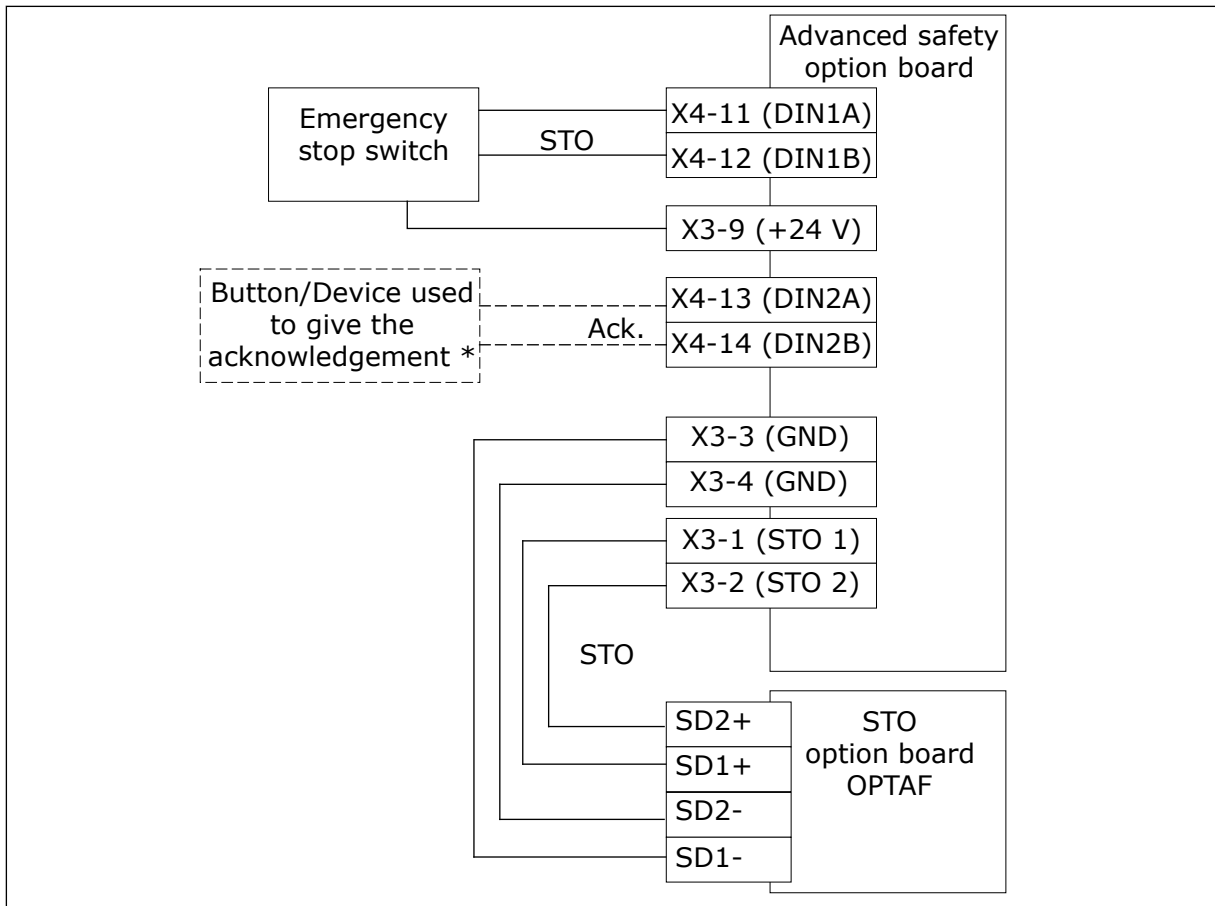

Fig. 7: Emergency stop configuration with the STO function and safe acknowledgement.

* = For some devices used for acknowledgement, additional wiring is required.

VACON[®]

www.danfoss.com

Vacon Ltd
Member of the Danfoss Group
Runsorintie 7
65380 Vaasa
Finland

Document ID:



DPD01919B

Rev. B

Sales code: DOC-QGASOPT+DLUK