



Find your nearest Vacon office
on the Internet at:

www.vacon.com

VACON NXP
AC DRIVES

IPOO MODULES
FRAMES FR10 TO FR14

INSTALLATION QUICK GUIDE

Manual authoring:
documentation@vacon.com

Vacon Plc.
Runsorintie 7
65380 Vaasa
Finland

Subject to change without prior notice
© 2012 Vacon Plc.

Document ID:



Rev. A



IPOO

QUICK INSTALLATION GUIDE

IP00 Module Installation Quick Guide

FR10, FR11, FI9, FI10, FI12, FI13 (FR12, FI14)

1-1 Products included in the delivery

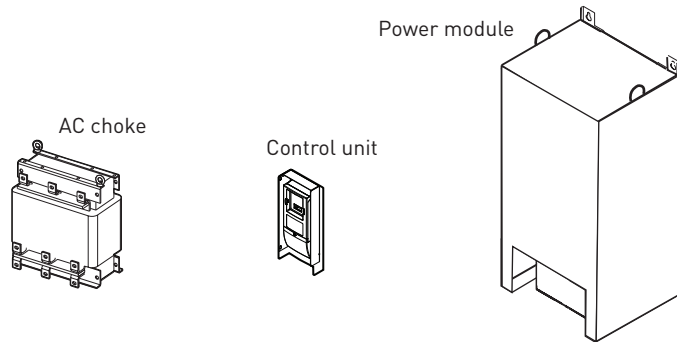

NOTE! FR12=2 x FR10; FI14=2 x FI13 power modules

1-2 Lifting the power module

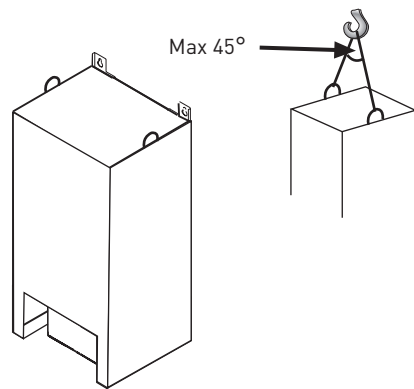

Frame	Weight kg
FR10	123
FR11	210
FI9	65
FI10	100
FI12	200
FI13	302

NOTE! Place the lifting hooks symmetrically in at least two holes. The lifting devices must be able to carry weight of the module

NOTE! Maximum allowed lifting angle 45°

3-2 Installing the optical fibres

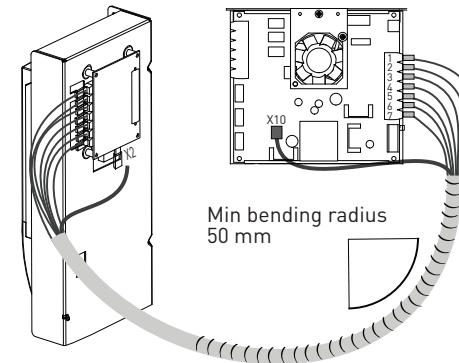

3-3 Installing the motor cable

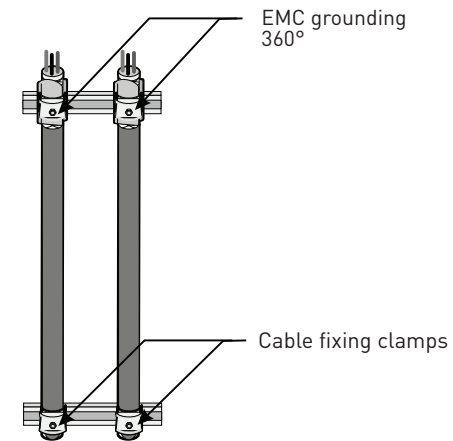

IP00 Module Installation Quick Guide

FR10, FR11, FI9, FI10, FI12, FI13 (FR12, FI14)

3-1 Connecting the internal power cable

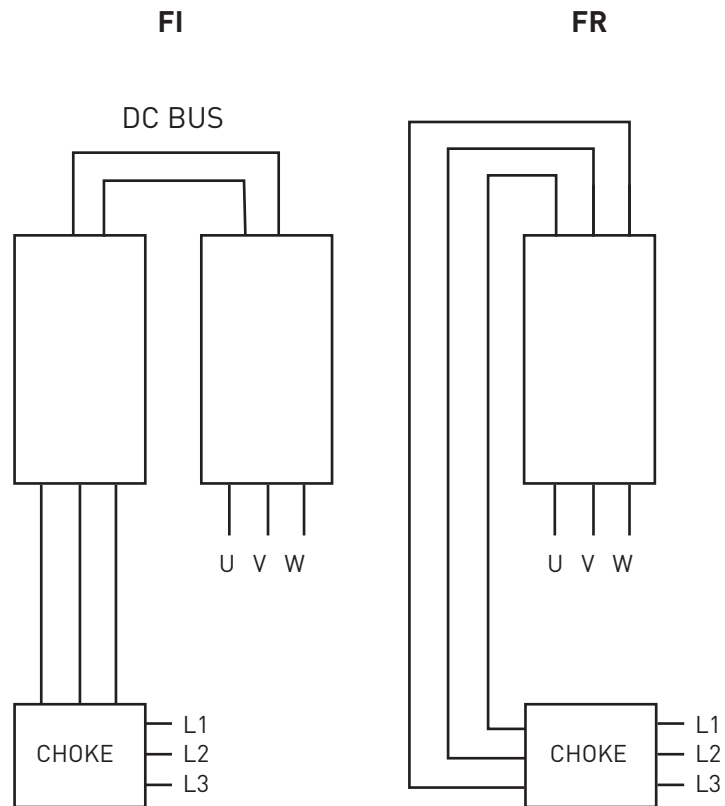

See IP00 Module Installation Manual for details.

1-3 Installing power module

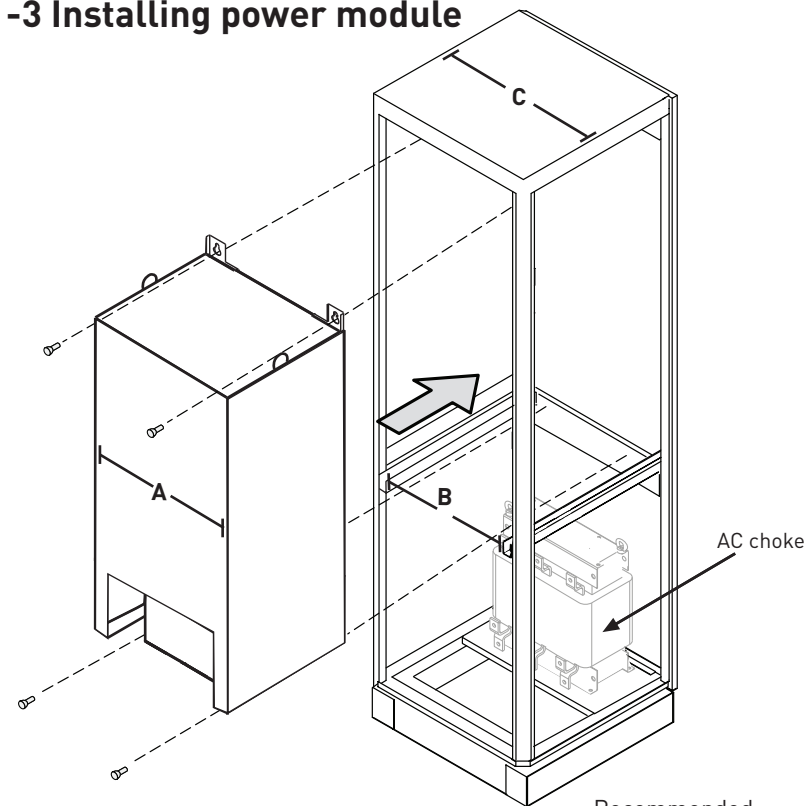

Frame	Device width A / mm	Supporting bar range B / mm	Recommended cabinet width C / mm
FR10	500	A - 50mm	600
FR11	709	A - 20mm	800
FI9	239	A - 50mm	400
FI10	239	A - 50mm	400
FI12	478	A - 50mm	600
FI13	708	A - 50mm	800

NOTE! For detailed drawing, see manual.

IP00 Module Installation Quick Guide

FR10, FR11, FI9, FI10, FI12, FI13 (FR12, FI14)

2-1 Steering the internal air flow

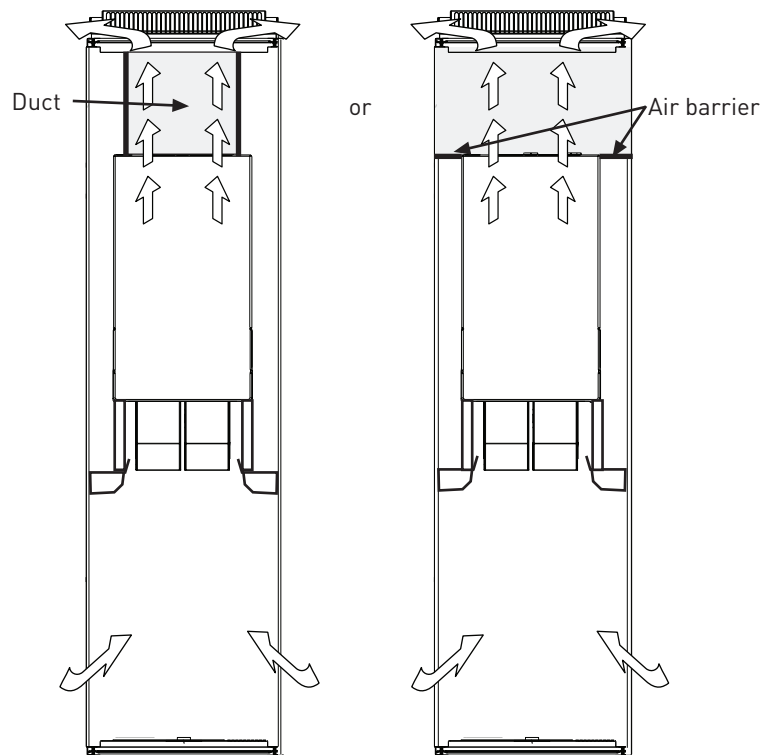

NOTE:

Outgoing air must be directed out of the cabinet so that it does not mix with incoming cooling air.

2-2 Arranging ventilation of the enclosure

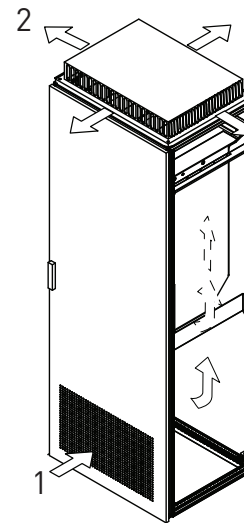

CAUTION!

It is of utmost importance for the operation and lifetime of the frequency converter that the enclosure is well ventilated to keep the temperature below the maximum operating temperature. Repeated overheating will shorten the lifetime of the converter.

Ventilation requirements table

Frame	Cooling air required m ³ /h	Minimum air hole on switchgear / dm ²	
		1) inlet	2) outlet
FR10	2800	13	7
FR11	4200	19,5	10,5
FI9	1150	5,5	3
FI10	1400	6,5	4
FI12	2800	13	7
FI13	4200	19,5	10,5