

VACON[®] NXP
AC DRIVES

**LIQUID-COOLED ENCLOSED DRIVE
HARDWARE MANUAL**

VACON[®]

Table 1. Manual revision history

Revision	Release date	Changes/updates
A	27.06.2014	First version
B	23.10.2014	Manual name change and small corrections
C	14.3.2019	Document layout updated

TABLE OF CONTENTS

Document: DPD01596C

Release date: 14.3.2019

1. Introduction	5
1.1 Scope of supply	5
1.2 Related brochures and manuals.....	5
1.3 Available drive sizes	6
2. Enclosed drive sections	7
2.1 Incoming section	8
2.2 Drive section.....	9
2.3 DU/DT and internal cooler section	10
2.4 Heat exchanger section.....	11
3. Installation.....	12
3.1 Safety notes	12
3.1.1 Danger.....	12
3.1.2 Warnings	13
3.1.3 Earthing and earth fault protection	14
3.2 Storage	15
3.3 Lifting and moving the cabinets.....	16
3.4 Fixing the cabinets	17
3.4.1 Free space around the cabinet.....	17
3.4.2 Fixing the cabinet to the floor or wall.....	18
3.5 Cabling.....	19
3.5.1 Earthing.....	19
3.5.2 Mains and motor connection	19
3.5.3 Cooling pipe connections	21
3.5.4 Control connections.....	22
3.6 Screw tightening torques.....	23
4. Service	24
4.1 Warranty.....	24
4.2 Proactive maintenance as recommended by manufacturer.....	24
4.3 Replacement instructions	28
4.3.1 Drives	28
4.3.2 Fuses.....	34
4.3.3 Cabinet fans for dU/dt and internal cooler.....	35
4.3.4 Internal cooler	37
5. Technical information	39
5.1 Control and interface	39
5.1.1 Control without speed feedback (open loop).....	39
5.1.2 Control with speed feedback (closed loop)	39
5.2 Load definitions	39
5.2.1 Pump and fan load	40
5.2.2 $OL(n_{base}) > OL(n_{max})$ for constant torque load	41
5.2.3 Starting torque $\gg OL(n_{max})$ for constant torque load	42
5.2.4 $OL(n_{base}) > OL(n_{max})$ for constant power load	43
5.2.5 $OL(n_{base}) < OL(n_{max})$ for constant power load.....	44
5.3 Technical specifications for VACON® NXP liquid cooled drives	45
6. Supplied documentation	49
6.1 Documentation examples	50
6.1.1 Cable connection table	50
6.1.2 Parts list.....	51
6.1.3 Wiring list.....	52
6.1.4 Circuit diagram	53
6.1.5 Switchgear layout drawing	54
6.1.6 Device layout drawing.....	55
7. Appendix.....	56
7.1 Power line circuit diagram.....	56
7.2 P&ID drawings	57

1. INTRODUCTION

The high power liquid cooled regenerative low harmonic enclosed drive is available in protection degree IP54. The single NXP Ch64 enclosed drive can be used with AC motors in power sizes up to 1550kW. The power range can be extended up to 5MW by using the innovative VACON[®] DriveSync control concept for running four Ch64 enclosed drives in parallel.

The VACON[®] NXP is a state-of-the-art AC drive for use in all applications where robustness, dynamic performance, precision and power are required. The VACON[®] NXP supports both induction motors and permanent magnet motors in open and closed loop control modes. The VACON[®] NXP also supports special motors such as high speed motors.

1.1 SCOPE OF SUPPLY

The scope of supply is limited to the drives listed in this manual. Process, machine or drive control systems are not part of Vacon Plc's scope of supply.

1.2 RELATED BROCHURES AND MANUALS

All user manuals and brochures are available in PDF format on the manufacturer's website at www.danfoss.com.

Table 2. Related user manuals and brochures

Document ID	Name of manual
BC00054	VACON [®] NXP Liquid Cooled Brochure
DPD00887	VACON [®] NXP Liquid Cooled User manual
UD01149	VACON [®] NXP HXL120 Cooling Unit Installation Manual
DPD01308	VACON [®] NXP HXM120 Cooling Unit Installation Manual

Also manuals for different applications and option boards are available on the manufacturer's website at www.danfoss.com.

1.3 AVAILABLE DRIVE SIZES

VACON® NXP liquid cooled enclosed drives are available in the voltage ranges 400-500V_{AC} and 525-690V_{AC}. The available drive sizes are listed below.

Table 3. Technical data for available drive sizes

Supply voltage [V _{AC}]	AC drive type	Drive/current			Electrical output power		Chassis	Dimensions WxHxD without cooling skid [mm]
		Thermal Chassis I _{TH} [A]	Rated		Optimum			
			Cont. I _L [A]	Cont. I _H [A]	Motor at I _{TH} (525V _{AC}) [kW]	Motor at I _{TH} (690V _{AC}) [kW]		
400-500	1370_5	1370	1245	913	700	900	Ch64	2000 x 2100 x 900
	1640_5	1640	1491	1093	900	1100	Ch64	2000 x 2100 x 900
525-690	0820_6	820	745	547	560	800	Ch64	2000 x 2100 x 900
	0920_6	920	836	613	650	850	Ch64	2000 x 2100 x 900
	1030_6	1030	936	687	700	1000	Ch64	2000 x 2100 x 900
	1180_6	1180	1073	787	800	1100	Ch64	2000 x 2100 x 900
	1300_6	1300	1182	867	900	1200	Ch64	2000 x 2100 x 900
	1500_6	1500	1364	1000	1000	1400	Ch64	2000 x 2100 x 900
	1700_6	1700	1545	1133	1150	1550	Ch64	2000 x 2100 x 900

2. ENCLOSED DRIVE SECTIONS

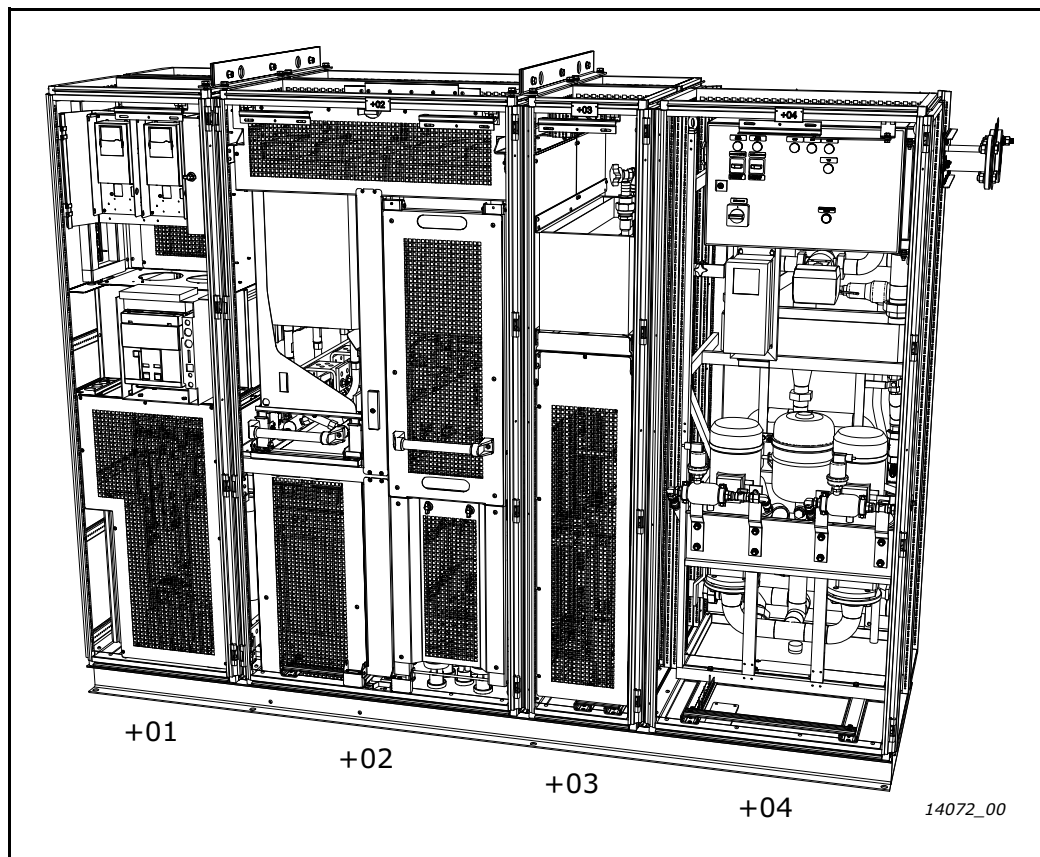

Figure 1. NXP liquid cooled enclosed drive sections

VACON® NXP Liquid cooled enclosed drive includes the following sections:

- +01: Incoming section
- +02: Drive section
- +03: DU/dt and internal cooler section
- +04: Heat exchanger section (optional)

NOTE! The enclosed drive is also available as a mirror image. The section order shown above is the standard.

2.1 INCOMING SECTION

The incoming section includes the mains connection, circuit breaker, LCL and control equipment.

As standard the incoming section has the following equipment:

- Q1: Main circuit breaker
- TR1: Control voltage transformer
- U1: AFE control module
- U2: INU control module
- C1: LCL capacitor
- F1: AC fuses
- L1: LCL
- V3, V4: Cooling fans
- X1...: Terminal blocks
- >L1,>L2,>L3: Mains connection L1, L2, L3

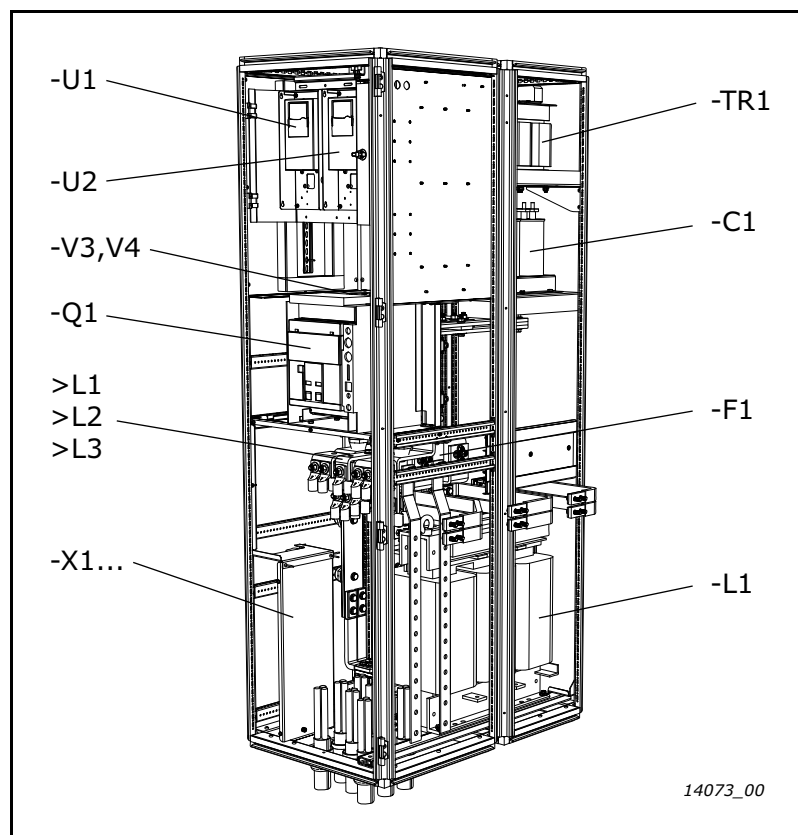

Figure 2. Incoming section

2.2 DRIVE SECTION

The drive section includes the VACON® NXP liquid cooled AFE and INU modules.

As standard the section includes the following:

- U1: AFE power module
- U2: INU power module
- F2: DC fuses
- L2: LCL
- >U, >V, >W: Motor connection

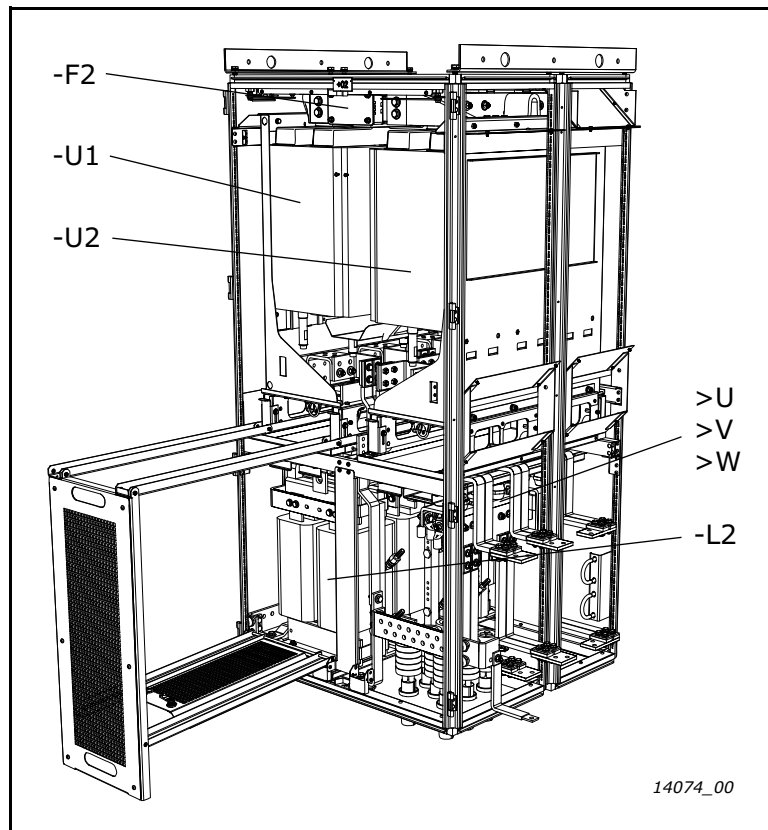

Figure 3. Drive section

2.3 DU/DT AND INTERNAL COOLER SECTION

This section includes a dU/dt filter and an internal cooler.

As standard the section includes the following:

- COOL1: Internal cooler
- V1,V2: Cooling fans
- L3: dU/dt filter

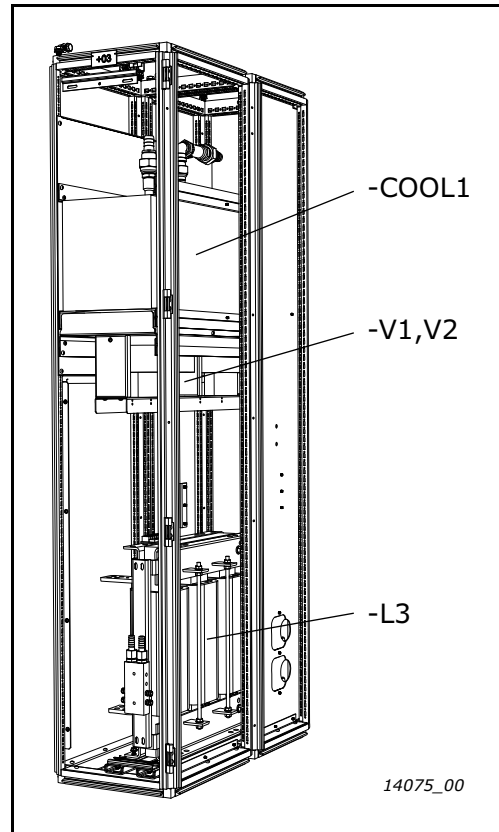

Figure 4. DU/DT and internal cooler section

2.4 HEAT EXCHANGER SECTION

The section includes a VACON® HXL/HXM 120 heat exchanger. This section is available as an option.

As standard the section includes the following:

- HEX1: Heat exchanger, HXL/HXM
- IN, OUT: DN50 flanges DIN2642, coolant in/out
- CTRL: Heat exchanger control unit

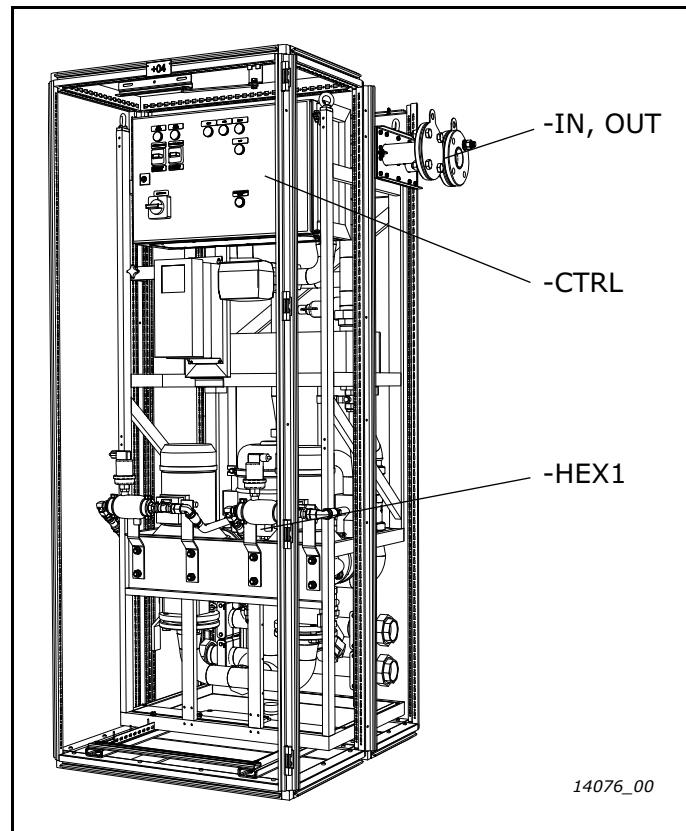

Figure 5. Heat exchanger section

3. INSTALLATION



3.1 SAFETY NOTES

NOTE! You can download the English and French product manuals with applicable safety, warning and caution information from <https://www.danfoss.com/en/service-and-support/>.

REMARQUE Vous pouvez télécharger les versions anglaise et française des manuels produit contenant l'ensemble des informations de sécurité, avertissements et mises en garde applicables sur le site <https://www.danfoss.com/en/service-and-support/>.

Read the information in cautions and warnings carefully.

The cautions and warnings are marked as follows:

	= DANGEROUS VOLTAGE!
	= GENERAL WARNING!



Only a competent electrician may carry out the electrical installation!

3.1.1 DANGER



The **components of the power unit and all cabinet mounted devices are live** when the drive is connected to mains potential. Coming into contact with this voltage is **extremely dangerous** and may cause death or severe injury.



The **motor terminals U, V, W, the DC bus/brake resistor terminals and all other mains devices are potentially live** when the drive is connected to mains, even if the motor is not running.



After disconnecting the AC drive from the mains, **wait** until the fan stops and the indicators on the keypad go out (if no keypad is attached see the indicators on the cover). Wait 5 more minutes before doing any work on the connections of the drive. Do not open the cabinet door before this time has expired. After expiration of this time, use measuring equipment to absolutely ensure that no voltage is present. **Always ensure the absence of voltage before starting any electrical work!**



The control I/O-terminals are isolated from the mains potential. However, the **relay outputs and other I/O-terminals may have a dangerous control voltage** present even when the drive is disconnected from mains.



Before connecting the drive to mains make sure that the drive front and cable covers as well as the cabinet doors are closed.



Before connecting the drive to mains ensure the functionality of the coolant circulation and check the circulation for possible leaks.



If the AC drive is disconnected from mains while running the motor, it remains live if the motor is energized by the process. In this case the motor functions as a generator feeding energy to the AC drive.

3.1.2 WARNINGS



VACON[®] AC drives are meant for **fixed installations only**.



Do not perform any measurements when the AC drive is connected to mains.



The **touch current** of VACON[®] AC drives exceeds 3.5 mA_{AC}. According to standard EN61800-5-1, a **reinforced protective ground connection** must be ensured. See Chapter 3.1.3.



If the drive is used as a part of a machine, the **machine manufacturer is responsible** for providing the machine with a supply disconnecting device (EN60204-1).



Only **spare parts** delivered by the manufacturer can be used.



At power-up, power brake or fault reset **the motor will start immediately** if the start signal is active, unless the pulse control for Start/Stop logic has been selected. Furthermore, the I/O functionalities (including start inputs) may change if parameters, applications or software are changed. Disconnect, therefore, the motor if an unexpected start can cause danger.



The **motor starts automatically** after automatic fault reset if the autoreset function is activated. See the Application Manual for more detailed information.



Prior to measurements on the motor or the motor cable, disconnect the motor cable from the drive.



Do not touch the components on the circuit boards. Static voltage discharge may damage the components.



Check that the **EMC level** of the AC drive corresponds to the requirements of the supply network.



Do not lift the AC drive from the plastic handles with an elevating device, such as jib crane or hoist.

3.1.3 EARTHING AND EARTH FAULT PROTECTION



CAUTION!

The AC drive must always be earthed with an earthing conductor connected to the earthing terminal marked with:



The touch current of the AC drive exceeds 3.5 mA_{AC}. According to EN61800-5-1, one or more of the following conditions for the associated protective circuit shall be satisfied:

A fixed connection and

- the **protective earthing conductor** shall have a cross-sectional area of at least 10 mm² Cu or 16 mm² Al, or
- an automatic disconnection of the supply in case of discontinuity of the **protective earthing conductor**, or
- provision of an additional terminal for a second **protective earthing conductor** of the same cross-sectional area as the original **protective earthing conductor**.

Table 4. Protective earthing conductor cross-section

Cross-sectional area of phase conductors (S) [mm ²]	Minimum cross-sectional area of the corresponding protective earthing conductor [mm ²]
S ≤ 16	S
16 < S ≤ 35	16
35 < S	S/2

The values above are valid only if the protective earthing conductor is made of the same metal as the phase conductors. If this is not so, the cross-sectional area of the protective earthing conductor shall be determined in a manner which produces a conductance equivalent to that which results from the application of this table.

The cross-sectional area of every protective earthing conductor which does not form part of the supply cable enclosure shall, in any case, be no less than:

- 2.5 mm² if mechanical protection is provided or
- 4 mm² if mechanical protection is not provided. For cord-connected equipment, provisions shall be made so that the protective earthing conductor in the cord shall, in the case of failure of the strain-relief mechanism, be the last conductor to be interrupted.

However, always follow the local regulations for the minimum size of the protective earthing conductor.

NOTE! Due to the high capacitive currents present in the AC drive, fault current protective switches may not function properly.



Do not perform any voltage withstand tests on any part of the AC drive. There is a certain procedure according to which the test shall be performed. Ignoring this procedure may result in a damaged product.

3.2 STORAGE

If the frequency converter is to be kept in store before use, make sure that the ambient conditions are acceptable:

- Storing temperature $-40\dots+70^{\circ}\text{C}$ (no cooling liquid inside cooling element allowed below 0°C)
- Relative humidity $<96\%$, no condensation

The environment should also be free from dust. If there is dust in the air, the converter should be well protected to make sure dust does not get into the converter.

If the converter is to be stored during longer periods, the power should be connected to the converter once in 24 months and kept on for at least 2 hours. If the storage time exceeds 24 months the electrolytic DC capacitors need to be charged with caution. Therefore, such a long storage time is not recommended.

If the storing time is much longer than 24 months, the recharging of the capacitors has to be carried out so that the possible high leakage current through the capacitors is limited. The best alternative is to use a DC power supply with adjustable current limit. The current limit has to be set for example to 300-500mA and the DC power supply has to be connected to the B+/B- terminals (DC supply terminals).

DC voltage must be adjusted to nominal DC voltage level of the unit ($1.35 \times U_{n_AC}$) and supplied at least for 1 hour.

If DC voltage is not available and the unit has been stored de-energized much longer than 1 year, consult factory before connecting power.



Always remove all cooling agent from the cooling element(s) before shipping to avoid damage caused by freezing.

3.3 LIFTING AND MOVING THE CABINETS

The cabinets are delivered either in a wooden box or a wooden cage. The boxes should be transported vertically. Transportation in a horizontal position is not allowed. Always refer to shipping marks for more detailed information. To lift the cabinets out of the box, use lifting equipment capable of handling the weight of the cabinets.

There are lifting lugs on the top of the cabinets and these lugs can be used to lift the cabinet into an upright position and to move it to the place needed.

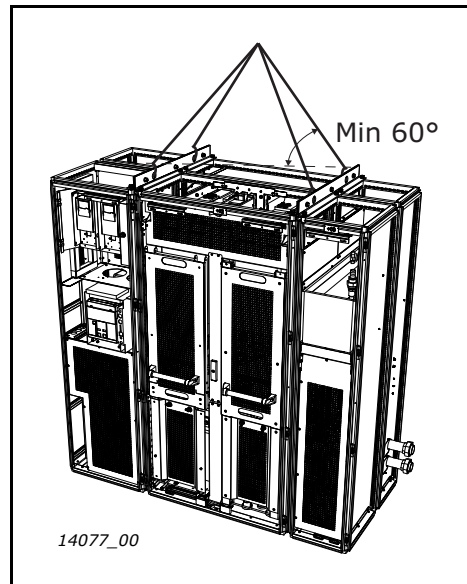

Figure 6. Lifting the cabinets

Moving of the cabinets on site can be carried out as follows by a forklift truck, a hoist or on rollers:

- Lower the package onto a level base
- Remove the package covering only at the site of installation
- Low, narrow or convoluted transport routes may require removal of the pallet prior to movement
- Move packages in the upright position only

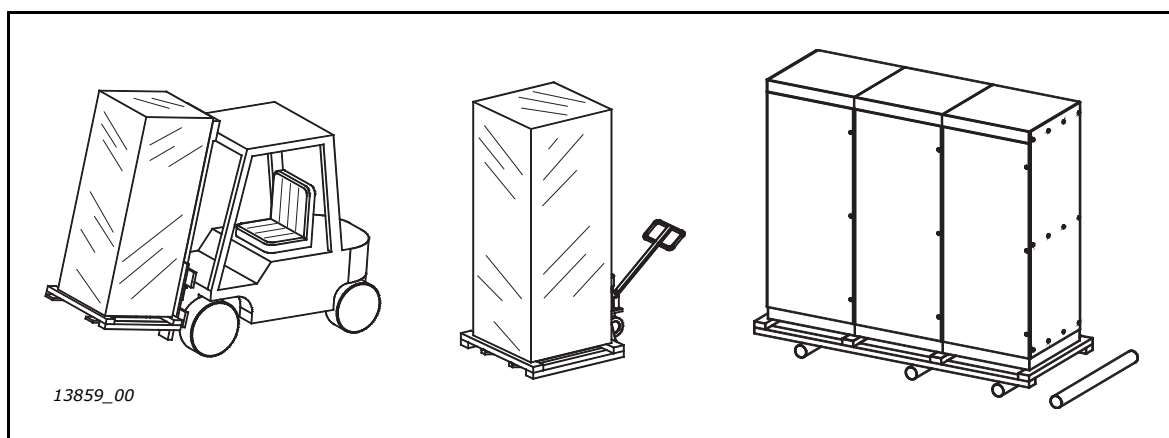

Figure 7. Moving the cabinets



Switchgear parts can easily topple backwards when manoeuvring on rollers or manual trolleys because their centre of gravity is typically located high up at the rear of the unit.

3.4 FIXING THE CABINETS

Before starting the installation work make sure that the level of the floor is within acceptable limits. The maximum deviation from the basic level can be no more than 5 mm over a 3 m distance. The maximum acceptable height difference between cabinet front and rear edges should be within +2/-0 mm limit.

The cabinet should always be fixed to the floor or to the wall. Depending on installation conditions, the cabinet sections can be fixed in different ways. There are holes in the front corners which can be used for fixing. Additionally, the rails on the top of the cabinet have fixing lugs for fixing the cabinet to the wall.

3.4.1 FREE SPACE AROUND THE CABINET

Enough space must be left above and in front of the cabinet to ensure sufficient cooling and space for maintenance.

It is recommended to leave at least 100 mm above and 1200 mm in front of the cabinets.

Also make sure that the temperature of the cooling air does not exceed the maximum ambient temperature of the drives.

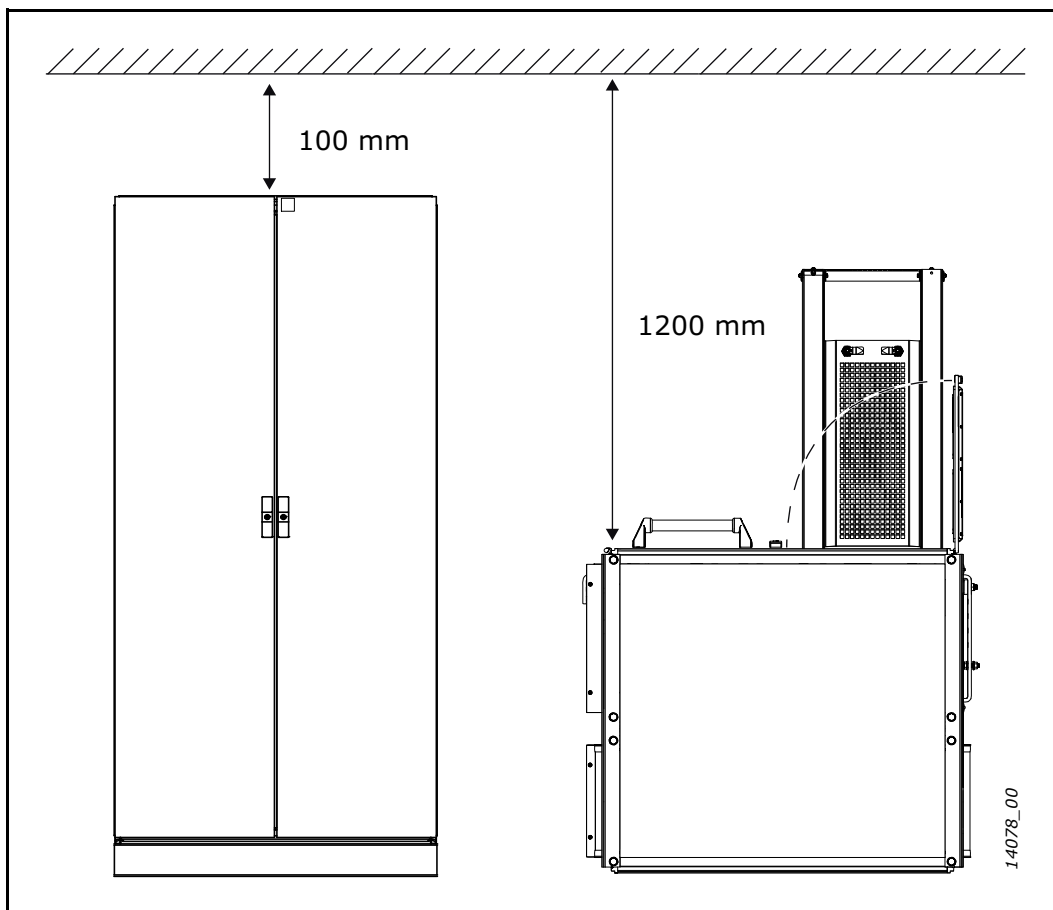

Figure 8. Required space around the cabinet

3.4.2 FIXING THE CABINET TO THE FLOOR OR WALL

In land based installations the cabinets are mounted on the floor with bolts.

In marine and off-shore installations the cabinets should be installed against a wall. The cabinets are mounted on the floor and the top of the cabinets to the wall. Also, vibration dampeners need to be installed on the bolts between the cabinets and the mounting surfaces. The vibration dampeners are not provided in the delivery.

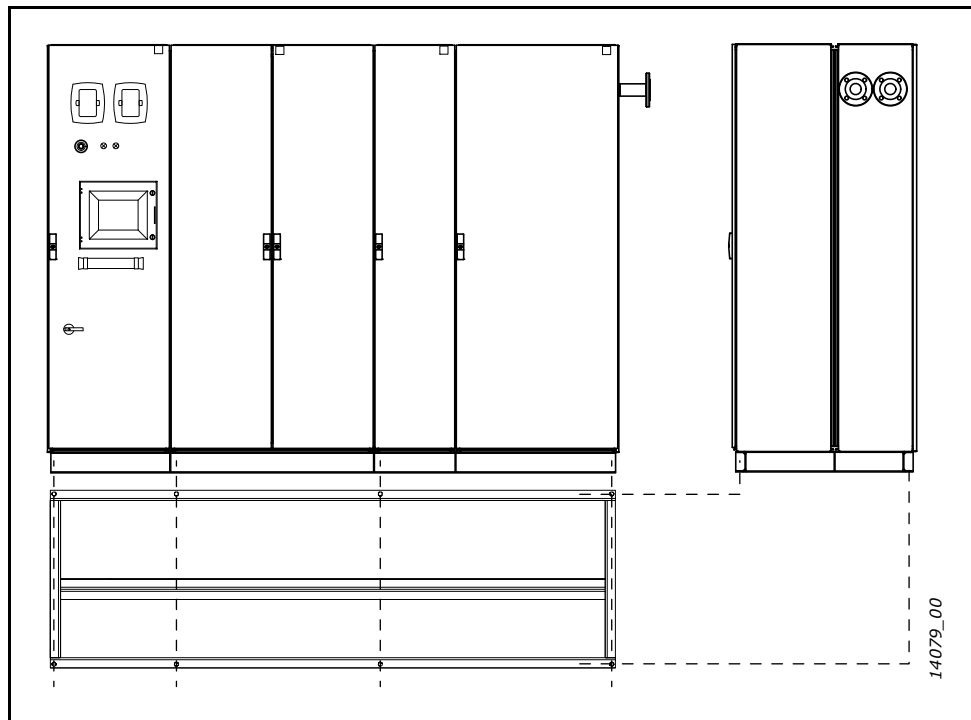

Figure 9. Fixing the cabinets to the floor

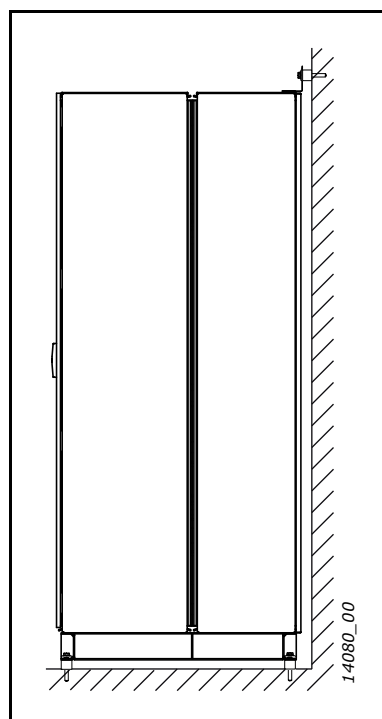

Figure 10. Fixing the cabinets in marine and off-shore installations

3.5 CABLING



Before connecting any cables, use a multimeter to check that the cables to be connected are not live.

3.5.1 EARTHING

PE conductors are connected to the PE busbar. The PE busbars in each section are connected and the PE busbars must be connected to earth.

See the earthing and earth fault protection instructions in Chapter 3.1.3.

3.5.2 MAINS AND MOTOR CONNECTION

The power supply terminals can be reached through the bottom part of the cabinet. The mains cables are connected to terminals L1, L2 and L3 on the incoming section (see Figure 11 on page 20). The motor cables are connected to drive section terminals marked with U, V and W. Make openings for the cables in the cable glands in the bottom of the cabinet and lead through the cables. There are eight size M63 cable glands available for both input and output. Use cable clamps to fix the cables.

Use cables with a temperature rating of at least +90°C. As a rule of thumb, cables and fuses can be dimensioned according to the frequency converter nominal output current, which you can find on the rating plate. Dimensioning according to the output current is recommended because the AC drive input current never significantly exceeds the output current.

Table 5. Cable types required to meet standards

Cable type	Level L (2 nd environment)	Level T
Mains cable	1	1
Motor cable	2	1/2*
Control cable	4	4

* Recommended

- Level L = EN61800-3, 2nd environment
- Level T = For IT networks
- 1 = Power cable intended for fixed installation and the specific mains voltage. Shielded cable not required (DRAKA NK CABLES - MCMK or similar recommended).
- 2 = Symmetrical power cable equipped with concentric protection wire and intended for the specific mains voltage (DRAKA NK CABLES - MCMK or similar recommended).
- 4 = Screened cable equipped with compact low-impedance shield (DRAKA NK CABLES - JAMAK, SAB/ÖZCuY-0 or similar).

See the more detailed cabling and fuse selection instructions in the corresponding user manual (see Table 2 on page 5).

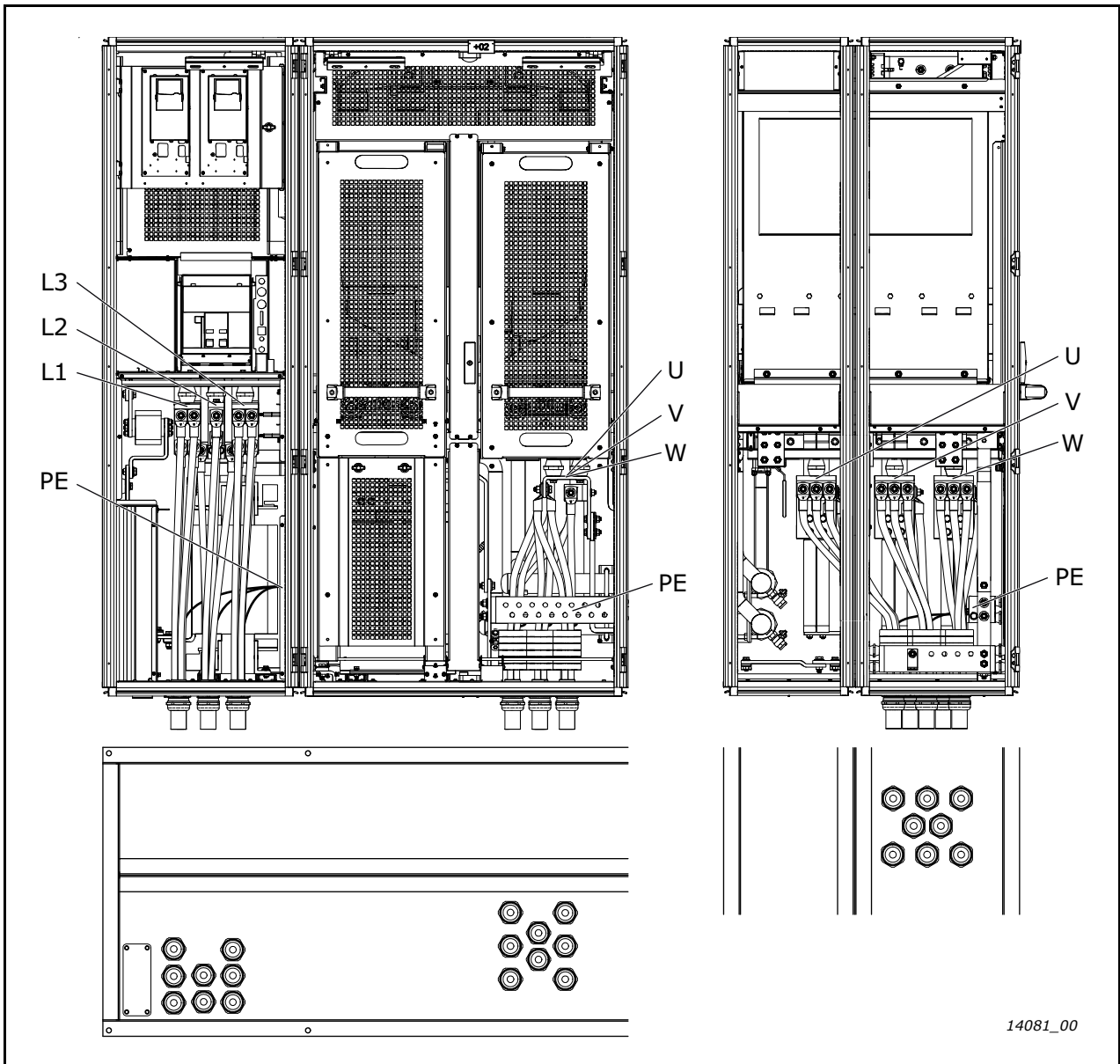

14081_00

Figure 11. Input and output cabling front view (left), side view of output cabling (right) and cable gland locations in the bottom of the cabinet (below).

3.5.3 COOLING PIPE CONNECTIONS

The cooling pipes are connected to the internal cooler section. See the NXP liquid cooled user manual for more information.

If a heat exchanger is installed, the cooling pipes are connected to that section. See the HXL/HXM installation manual for more information.

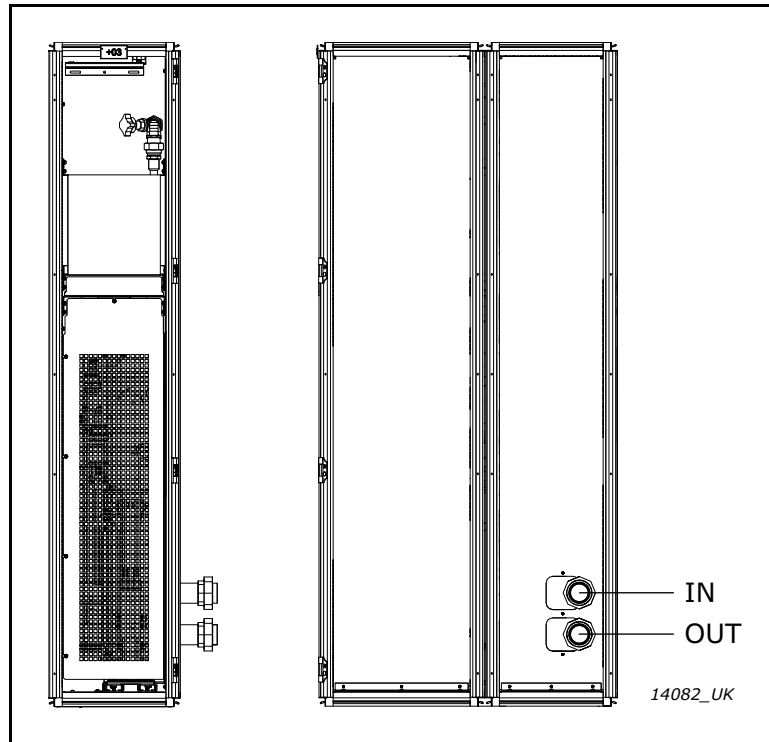

Figure 12. Cooling pipe connections to internal cooler

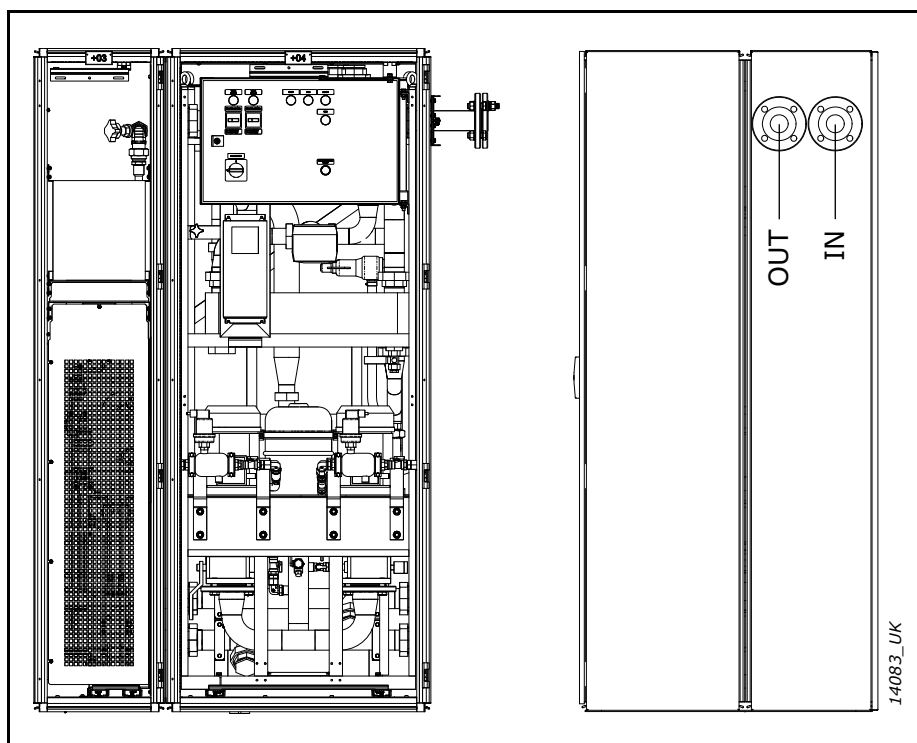

Figure 13. Cooling pipe connections to heat exchanger

3.5.4 CONTROL CONNECTIONS

The control unit of the AC drive consists roughly of the control board and additional boards connected to the five slot connectors (A to E) of the control board. The control board is connected to the power unit through a D-connector or fibre optic cables.

Usually, when the frequency converter is delivered from the factory, the control unit includes at least the standard compilation of two basic boards (I/O board and relay board) which are normally installed in slots A and B.

The control board can be powered externally (+24V, $\pm 10\%$) by connecting the external power source to either of the bidirectional terminals. This voltage is sufficient for parameter setting and for keeping the fieldbus active.

For more detailed cabling instructions, see the corresponding user manual (see Table 2 on page 5).

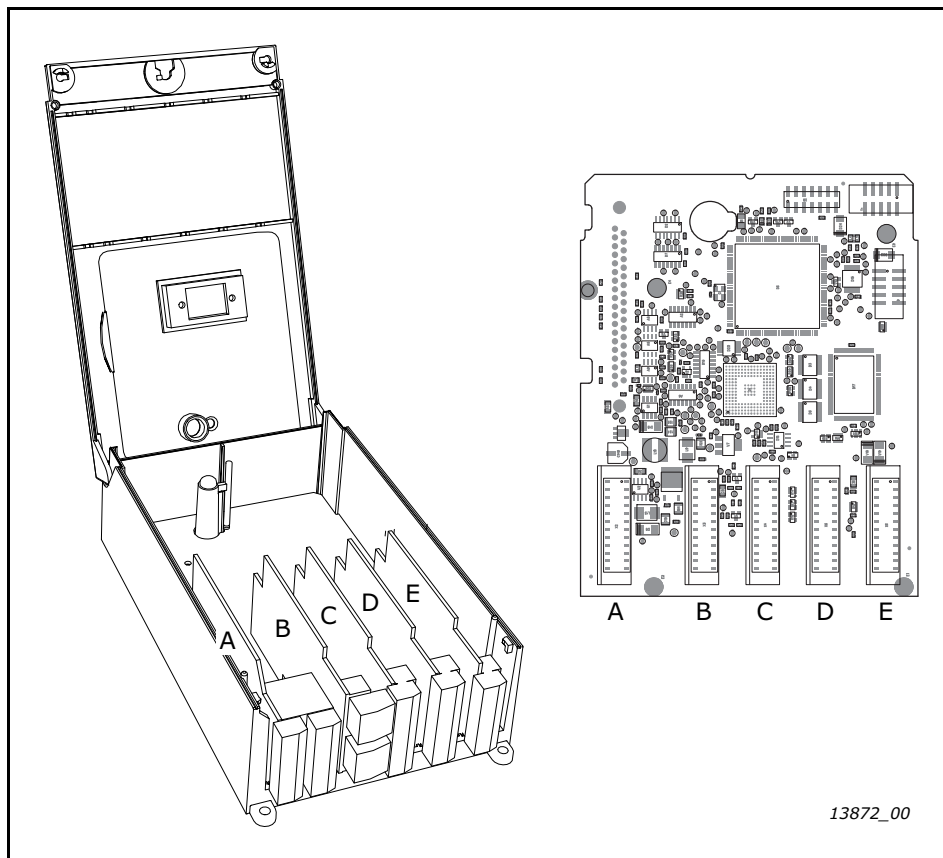

Figure 14. Control unit, control board (right) and option boards (A-E)

3.6 SCREW TIGHTENING TORQUES

The tightening torques of all power connections (cables and busbars) for different screw and bolt sizes are given in table below.

Table 6. Tightening and checking torques of power connections

Screw/bolt size	Checking torque (Nm)	Tightening torque (Nm)
M6	8	10
M8	18	22
M10	35	45
M12	65	75

The tightening torques for control unit terminals are given below.

Table 7. Tightening torques of control unit terminals

Terminal screw	Tightening torque (Nm)
Relay and thermistor terminals (screw M3)	0.5
Other terminals (screw M2.6)	0.2

4. SERVICE

4.1 WARRANTY

Only manufacturing defects are covered by the warranty. The manufacturer assumes no responsibility for damages caused during or resulting from transport, receipt of the delivery, installation, commissioning or use.

The manufacturer shall in no event and under no circumstances be held responsible for damages and failures resulting from misuse, wrong installation, unacceptable ambient temperature, dust, corrosive substances or operation outside the rated specifications.

Neither can the manufacturer be held responsible for consequential damages.

The Manufacturer's warranty period is 18 months from the delivery or 12 months from the commissioning whichever expires first (VACON[®] PLC general terms and conditions of sale).

The local distributor may grant a warranty time different from the above. This warranty time shall be specified in the distributor's sales and warranty terms. The manufacturer assumes no responsibility for any other warranties than that granted by the manufacturer itself.

In all matters concerning the warranty, contact your distributor first.

4.2 PROACTIVE MAINTENANCE AS RECOMMENDED BY MANUFACTURER

All technical devices, drives as well, need a certain amount of caretaking and failure preventive maintenance. To maintain trouble-free operation of VACON[®] AC drives, environmental conditions, as well as load, line power, process control, etc. have to be within specifications, determined by manufacturer.

If all conditions are in accordance with the manufacturer's specifications, there are no other concerns, but to provide a cooling capacity high enough for the power and control circuits. This requirement can be met by making sure, that the cooling system works properly. Operation of cooling fans and cleanness of the heat sink should be verified regularly.

Regular maintenance is recommended to ensure trouble free operation and long lifetime of VACON[®] AC drives. At least the following things should be included in the regular maintenance.

NOTE! It is recommended to record all actions and counter values with dates and time for follow up of maintenance.

Table 8. Proactive maintenance schedule

	Item	Inspection interval	Service interval	Maintenance actions
AC drives	Conditions of installation environment	1 year	1 year	Check that installation and environment conditions are within VACON® specification. E.g. heat, dust, moisture, vibration etc. Corrective actions based on findings.
	Cleaning	1 year	1 year	If required the product will be cleaned with an antistatic vacuum cleaner.
	Cleanliness of cooling tunnel	1 year	1 year	The cleanliness of the cooling tunnel for air cooled drives will be checked/evaluated (VFD in Heat Exchanger unit). Cleaning if necessary.
	Sealings	1 year	Based on inspection	Check drive system sealings (AC drive, cabinet etc). Check visually cable bushing. Corrective actions based on findings.
	Main DC cooling fans and internal cooling fans for electronics	1 year	5 years	Replace parts according to service schedule or based on maintenance report recommendation. Note, Liquid cooled drives have internal cooling fans. VFD in Heat Exchanger unit have a main cooling fan. Spare parts available from VACON® and instructions on service manuals.
	DC bus capacitors		8 years (demanding environment or heavy load) 12 years (typical environment or normal load)	The expected life time of the capacitor is determined based on load and the temperature of the environment. Replace parts according to service schedule. Currently this service is available only from VACON®.
	Product upgrades	1 year	1 year	Manufacturer offers product upgrades.
	Printed circuit boards	1 year	12 years in typical environment	The printed circuit boards to be checked for contamination and possible corrosion. In case of contamination or corrosion printed circuit boards to be changed.
	Recommended reforming interval for electrolytic DC bus capacitors	1 year	1 year	Reforming must be done once a year for products and spare part capacitors in storage. Consult manufacturer.

Table 8. Proactive maintenance schedule

	Item	Inspection interval	Service interval	Maintenance actions
Liquid cooling system	Coolant inhibitor	1 year	2 years	Add inhibitor according to instructions or analyze the coolant and add inhibitor based on result.
	Coolant	2 years	5 years	Check and change coolant according to service schedule.
	NX liquid cooled drive coolant flow	1 year	Based on inspection	Check pressure, flow and temperature of the system. Compare to previous measurement. Temperature alarm or trip indicates that AC drive warms up and the flow is too low. Cleaning of heatsink if necessary, consult manufacturer
	Coolant leakage	3 months	Based on inspection	Open the cubicle doors and checking that no visible leaks can be found on cooling unit or coolant manifold connections. If a leak is found the unit has to be shut down and the leak repaired.
	Cooling unit, expansion tank	1 year	Based on inspection	Check that the pre-pressure of the expansion vessel and coolant circuit pressure is at required level. The pre-pressure of the expansion vessel should be 1.0 bar and the coolant circuit pressure should be 1.5 bar when will with coolant. For other cooling units according to manufacturer information. If the pressure is too low it must be rectified.
	Cooling unit, pump	1 year	Based on inspection	Check for possible leakage of the pump shaft sealing. During the life cycle of the pump, it is likely that the shaft seal will have to be changed at some point. Change pump or pump sealing according to manufacturer instructions. Check flow of the system and compare to previous measurement.
	Cooling unit, heat exchanger	1 year	Based on inspection	Check cooling capacity (flow and temperature) of the heat exchanger. (High temperature alarm active.) Check 3- way valve operation and make a adaption run to verify that the valve opens and closes completely. Possible biological residue clogging the heat exchanger on customer side, clean heat exchanger according manufacture instructions.

Table 8. Proactive maintenance schedule

	Item	Inspection interval	Service interval	Maintenance actions
Cabinet, cabling and connections	Cabinet, auxiliary devices (contactors, switches, relays, push buttons, indicators, etc.)	1 year	According to manufacturer information	Replace parts according to service schedule or based on maintenance report recommendation.
	Sealings	1 year	Based on inspection	Check cabinet and drive sealings. Check visually the cable bushings. Corrective actions based on findings.
	Visual inspection of cabling	1 year	1 year	Visual inspection for possible damages etc., e.g. vibration. Actions based on inspection.
	Tightness of connections	1 year	1 year	Cable and wire connections to be checked and tighten.
	Radiator cooling fans and control compartment fans	1 year	5 years	Check the operation of the fans and measure the radiator fan capacitor every 2 years. Replace parts according to service schedule or based on maintenance report recommendation.

4.3 REPLACEMENT INSTRUCTIONS



Servicing is only permitted to be carried out by VACON® trained service personnel!

4.3.1 DRIVES

1	<p>Open the cabinet doors.</p>
2	<p>Release the locking mechanism (1) for the dropdown service rails and pull them down from the handle (2).</p> <p>NOTE! The dropdown rails are heavy.</p> <p>NOTE! Only use the dropdown rails when the rails are horizontal and the front support legs create a 90 degree angle with the floor.</p> <div style="text-align: center;"> <p style="text-align: right; font-size: small;">14084_00</p> </div> <p style="text-align: center;"><i>Figure 15. Dropdown service rails</i></p>

3

Remove the middle support plate. It is attached with two M5x10 (1) and two M6x10 (2) screws.

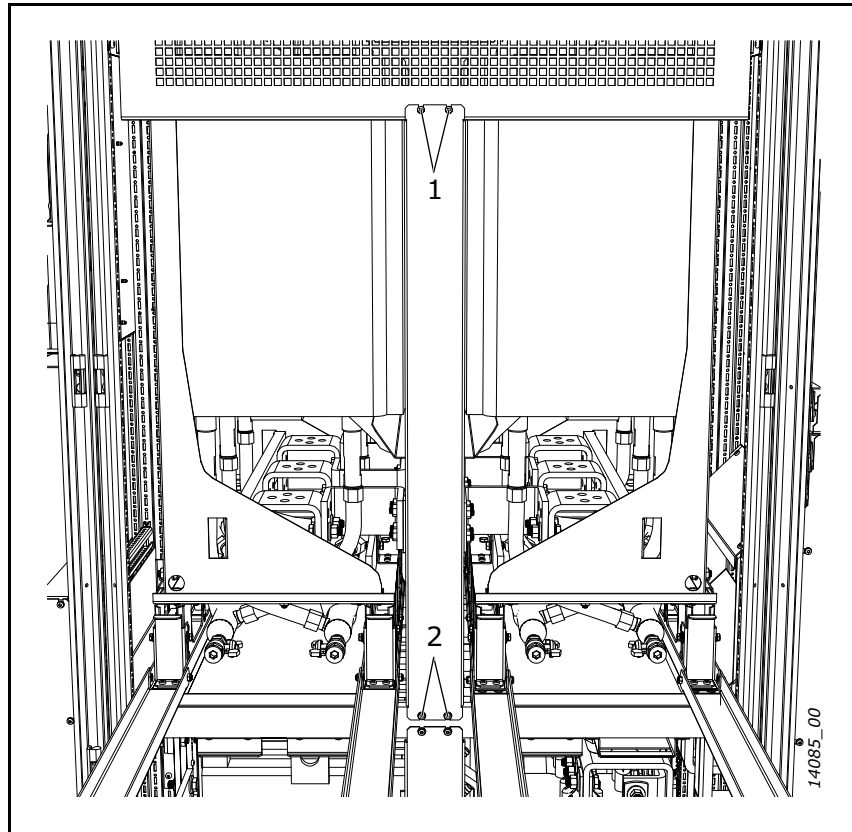

Figure 16. Middle support plate mounting screws

4

Remove the touch protection cover. It is attached with six M5x10 screws.

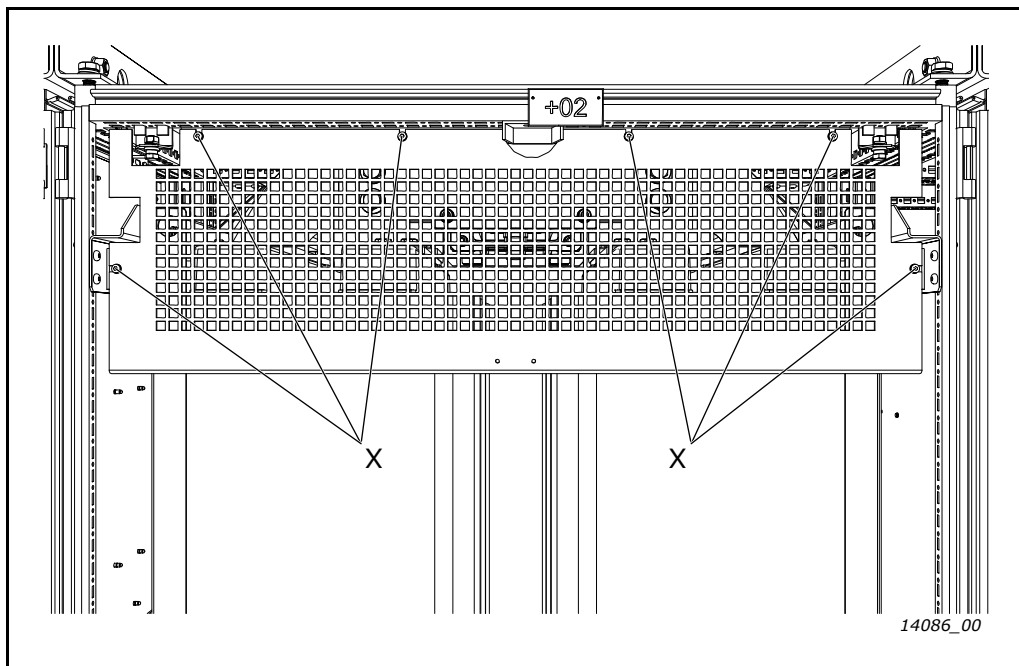

Figure 17. Touch protection cover mounting screws (X)

5

1. Turn off the main coolant valves under the drives (-UVL11, -UVL21, -UVL12, -UVL22, see Figure 47 on page 57).
NOTE! Remove the handles from the valves to prevent accidental opening during the maintenance operation.
2. Drain the coolant from the two valves in front of each drive (-DVL11, -DVL21, -DVL12, -DVL22).

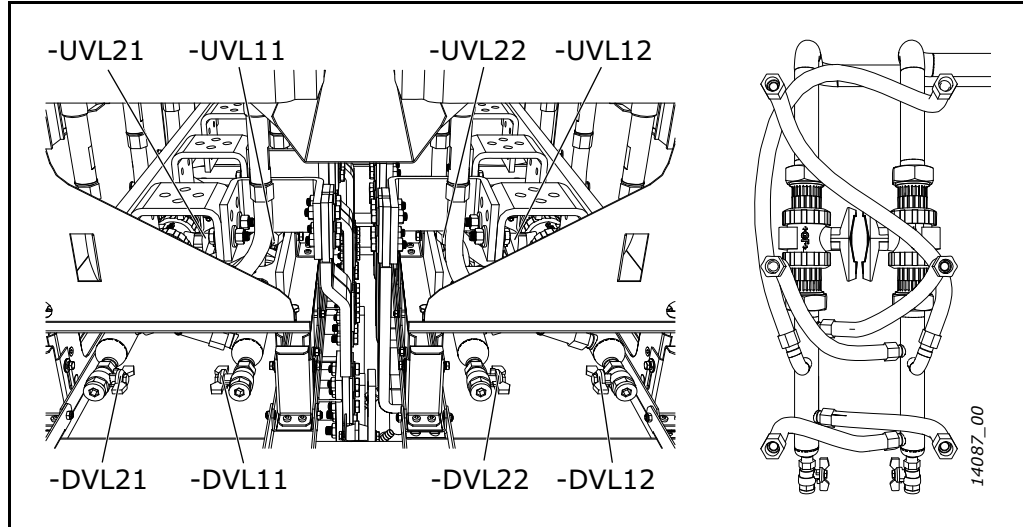

Figure 18. Coolant valves (piping detail from above, right)

6

Release the DC busbars from the top of the drives. There are four busbars and each is attached with two 19mm bolts.

NOTE! Only use tools on the bolt heads. The nuts are pressed into the busbar and tools are only to be used in the unlikely event of loosening.

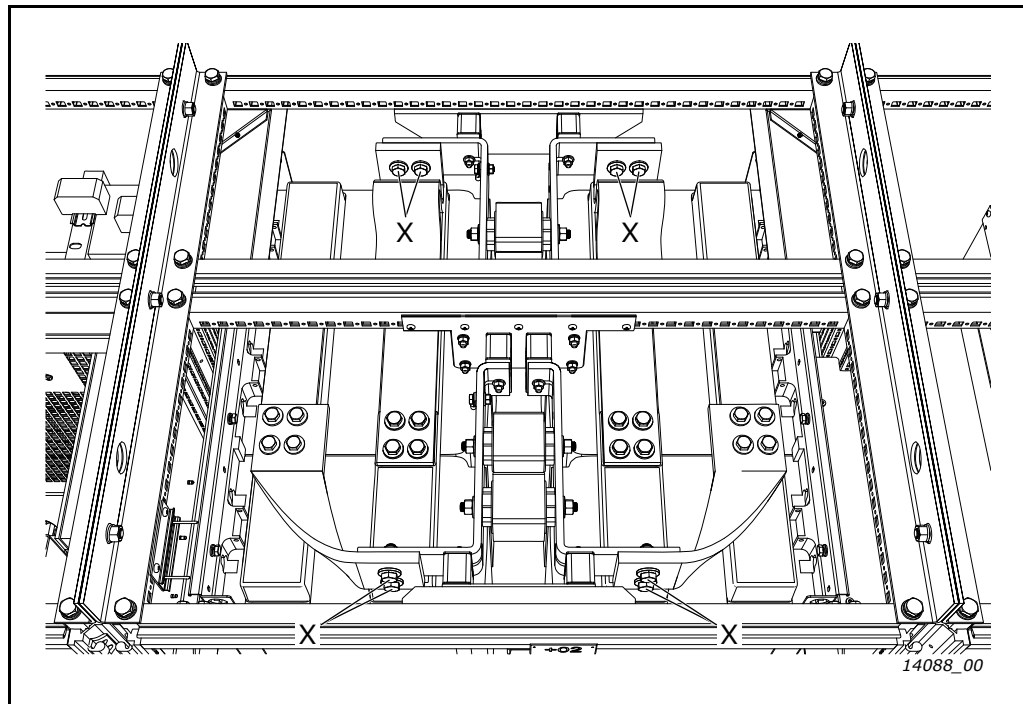

Figure 19. DC busbar mounting screws (X)

7

Release the top parts of the drive(s) from the cabinet. Each drive is attached with four M8x20 bolts.

NOTE! Only use tools on the bolt heads. The nuts are pressed into the busbar and tools are only to be used in the unlikely event of loosening.

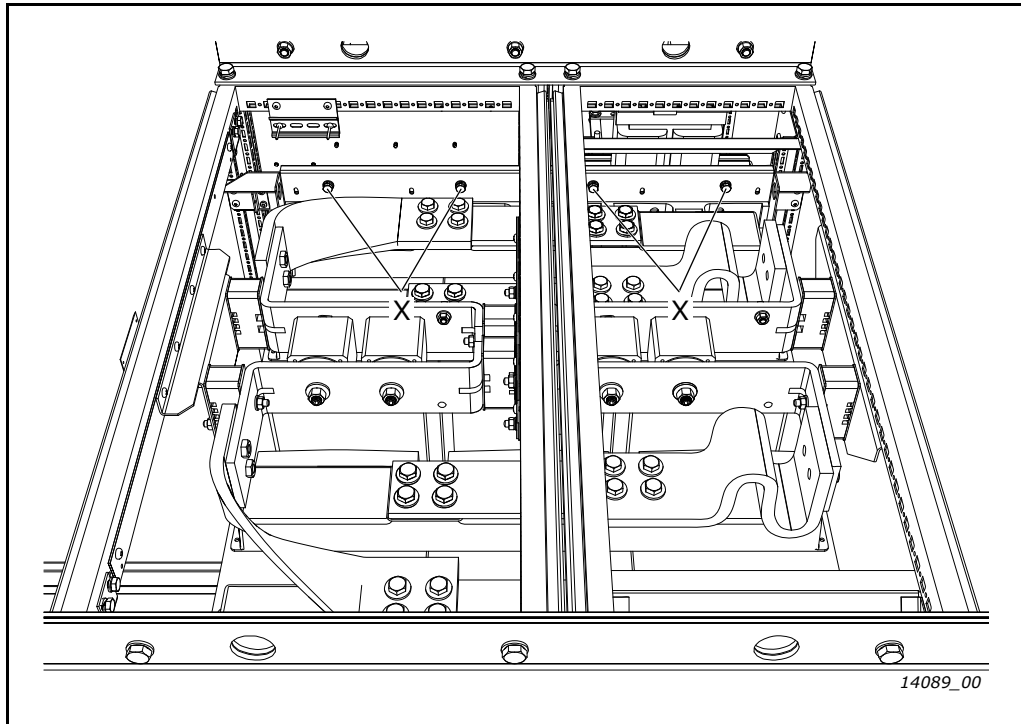

Figure 20. Drive top part mounting screws (X)

8

Release the AC busbars from the drive(s). There are three busbars connected to each drive and each busbar is attached with four M10x40 bolts.

NOTE! Only use tools on the bolt heads. The nuts are pressed into the busbar and tools are only to be used in the unlikely event of loosening.

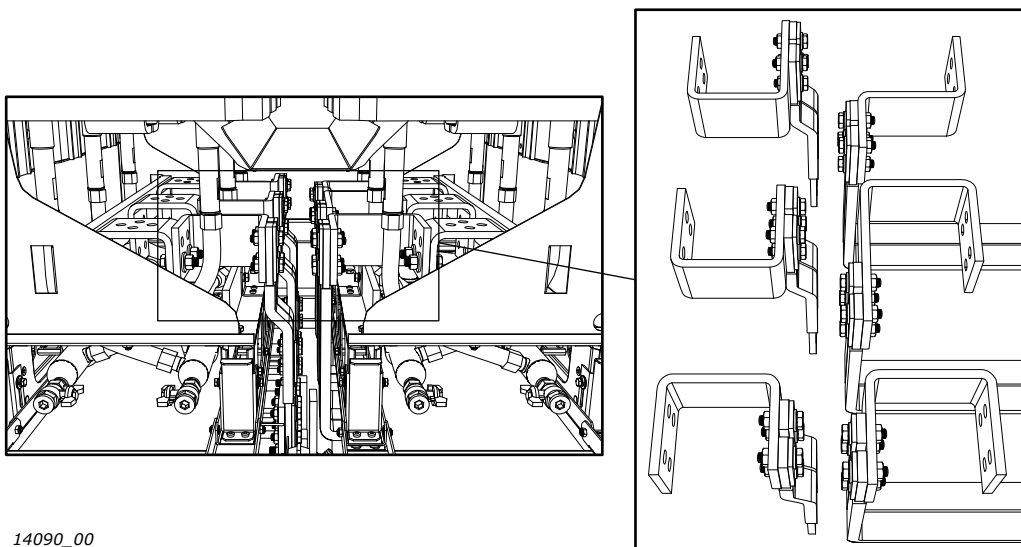

Figure 21. AC busbars

9

Release the coolant pipes from the drive side of the main valves (see below).

NOTE! Do not use any tools on the plastic valves or their connections.

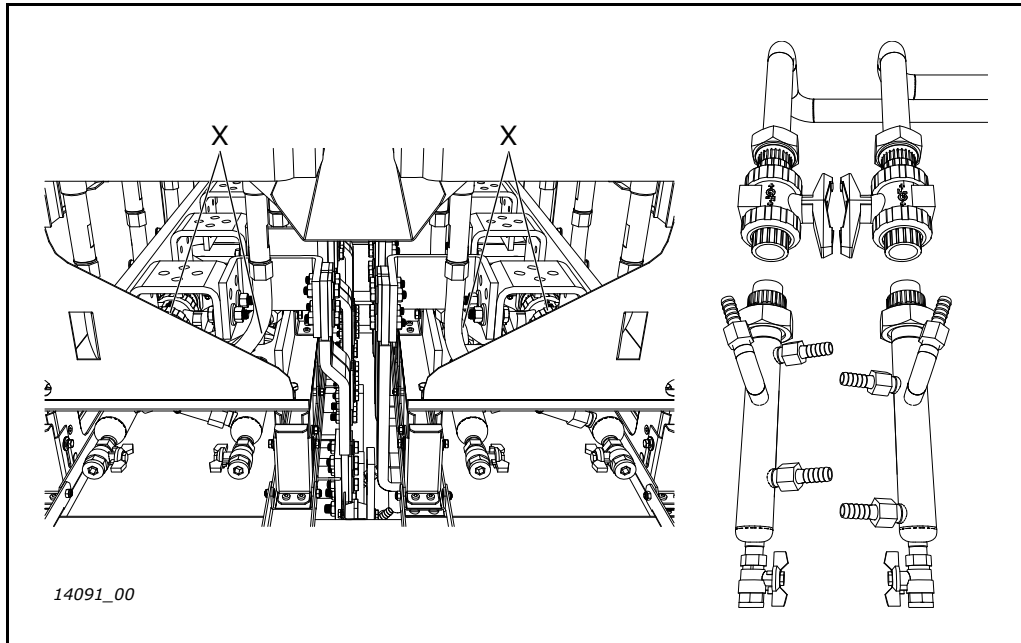

Figure 22. Coolant pipe releasing locations (X). See the detail on the right.

10

To release the drives, remove the holder brackets (two for each drive). The brackets are attached with two M6x10 screws (1) from the front and two M6x12 bolts (2) from the sides.

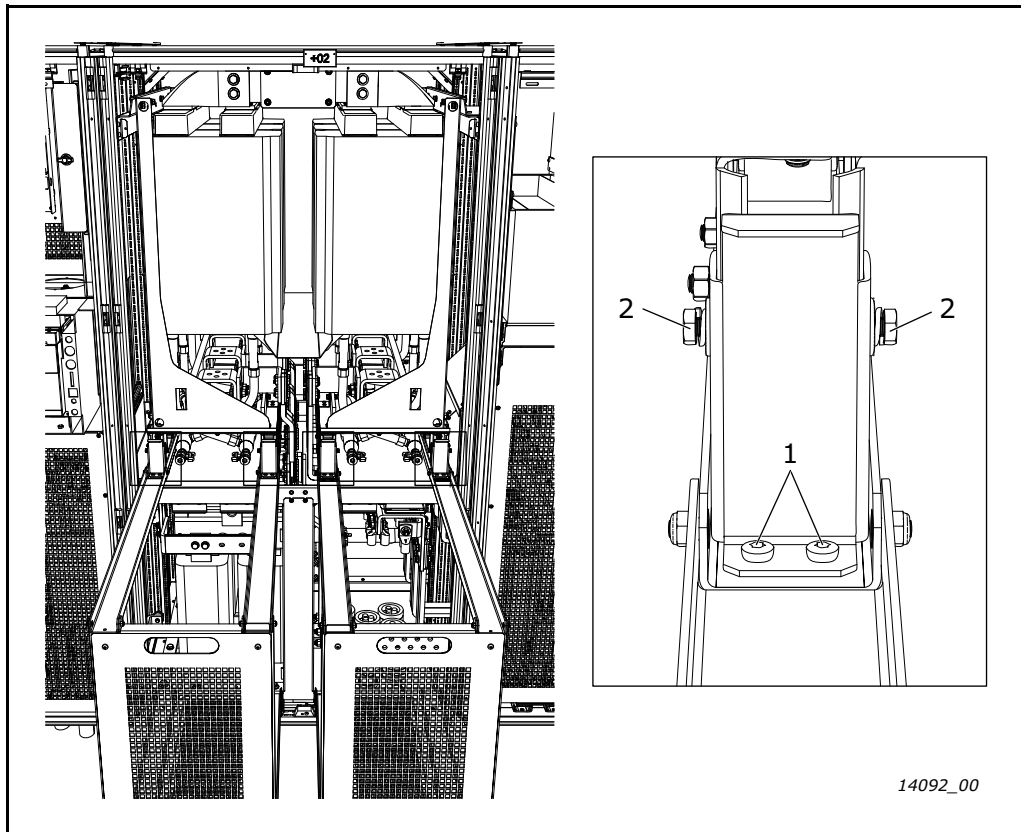

Figure 23. Drive holder brackets

11

Pull out the drives from the cabinet.

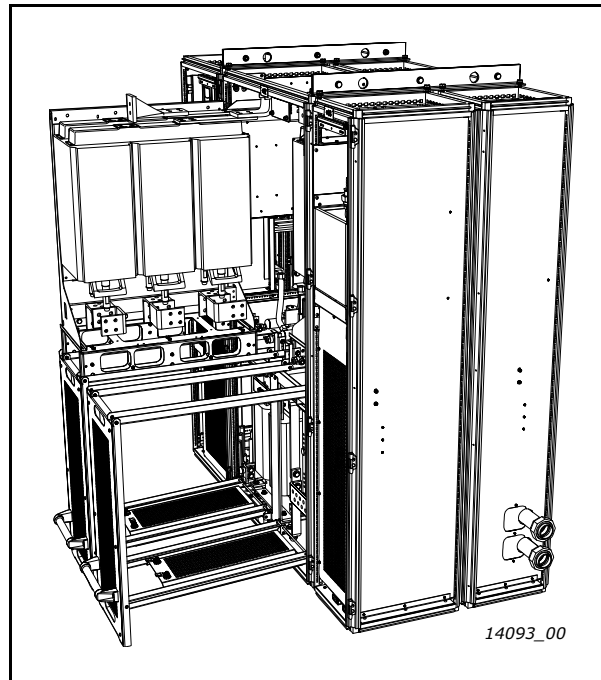

Figure 24. Pulling the drives from the cabinet

4.3.2 FUSES

4.3.2.1 DC fuses

The DC fuses (-F2.1, -F2.2, -F2.3, -F2.4) are located above the drives in the top part of the drive section. They can be accessed from the top of the cabinet. There are two 1400A fuses on each busbar (DC+ and DC-) and each fuse is attached with two M12 nuts.

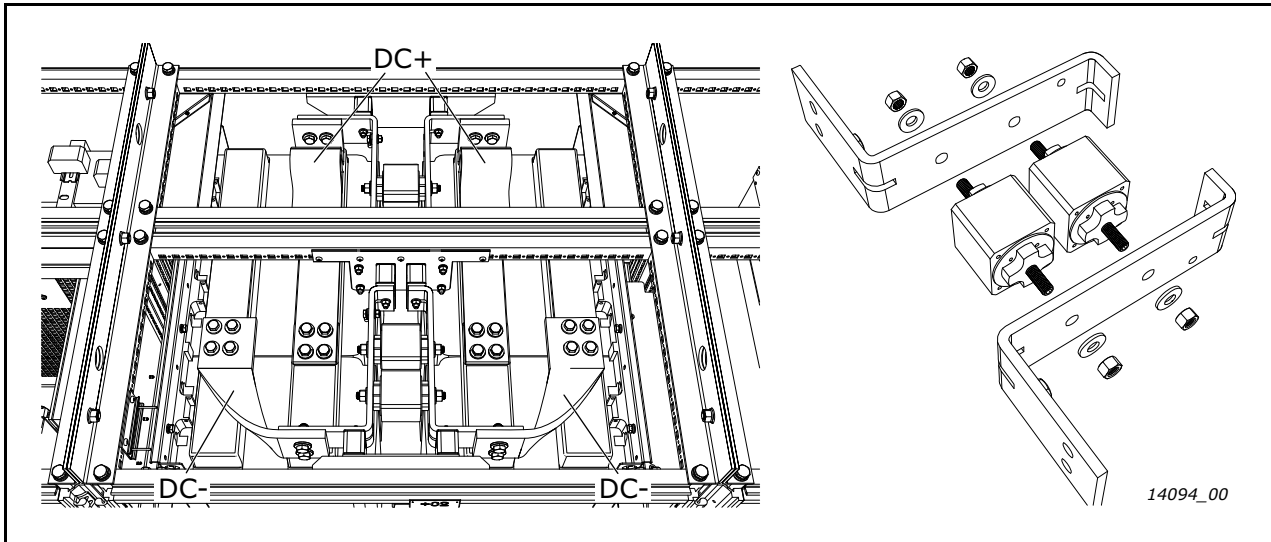

Figure 25. DC fuses

4.3.2.2 AC fuses

The AC fuses (-F1.1, -F1.2, -F1.3) are located under the main circuit breaker in the bottom part of the incoming section. There are three 2400A fuses, one for each phase, and each fuse is attached with eight M10 nuts (four on each side of the fuse).

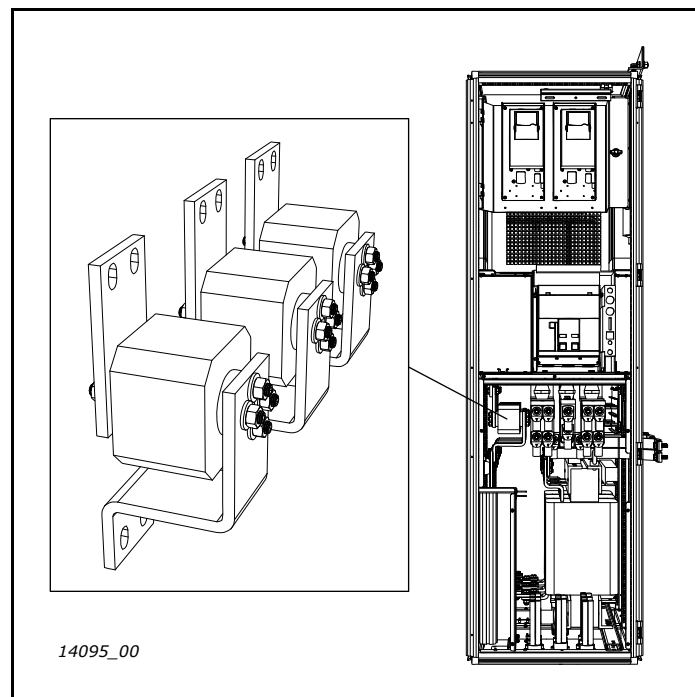

Figure 26. AC fuses

4.3.3 CABINET FANS FOR DU/DT AND INTERNAL COOLER

1

Open the cabinet door and remove the touch cover. It is attached with five M5x10 screws.

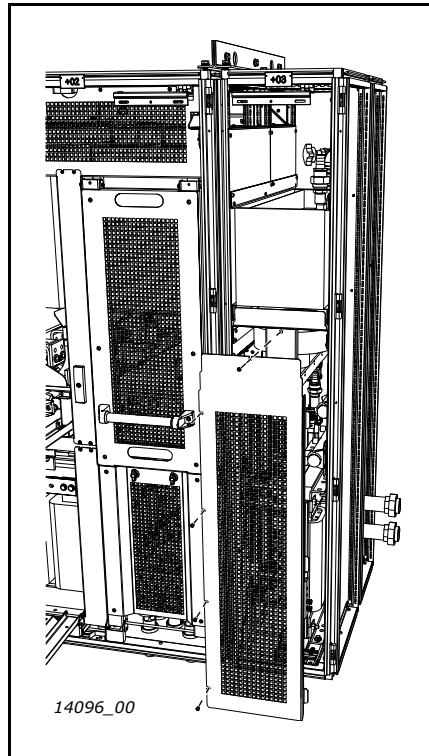

Figure 27. Removing the touch cover

2

1. Disconnect the fan supply wire from connector +03-XV1.
2. Remove the two M6x10 screws holding the fan assembly.

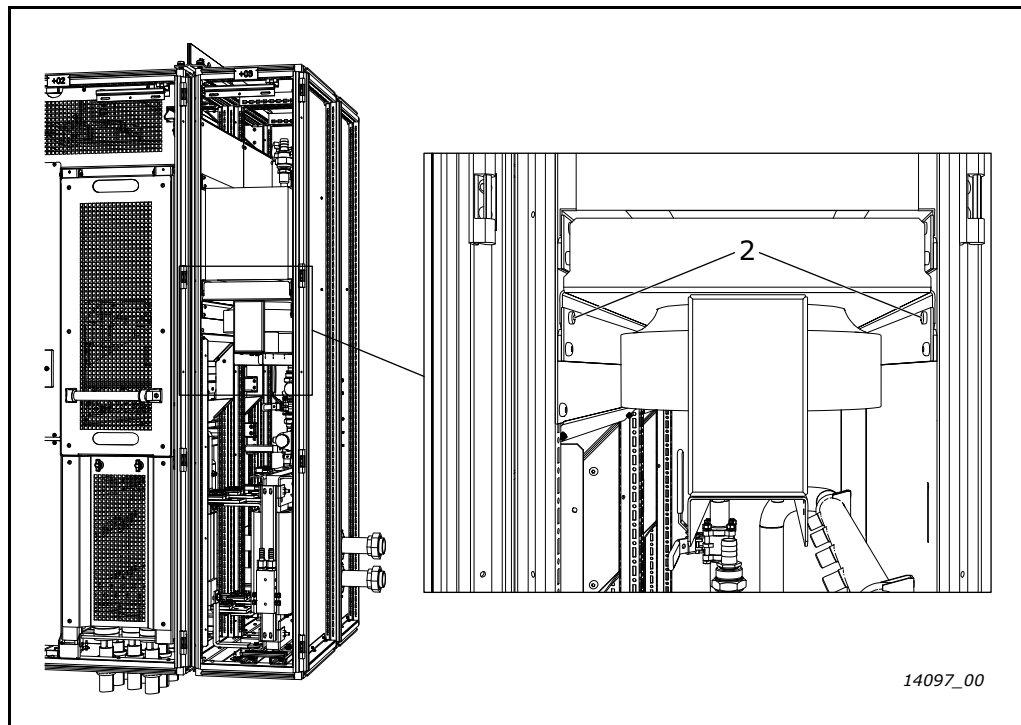

Figure 28. Fan assembly mounting screws and fan supply connector

3

Pull out the whole fan assembly.

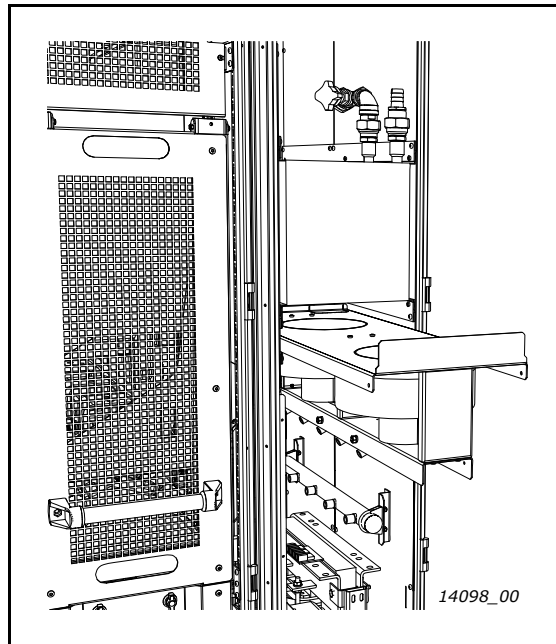

Figure 29. Pulling out the fan assembly

4

The fan capacitors are located under the fan assembly.

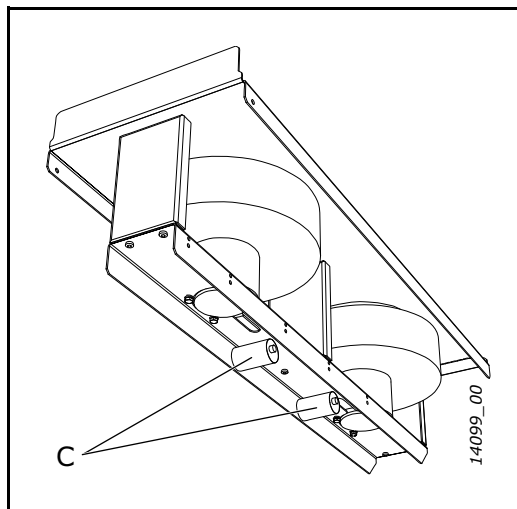
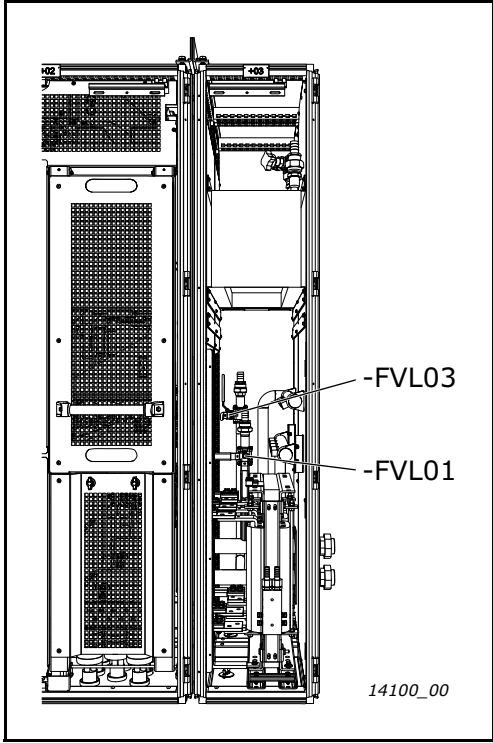
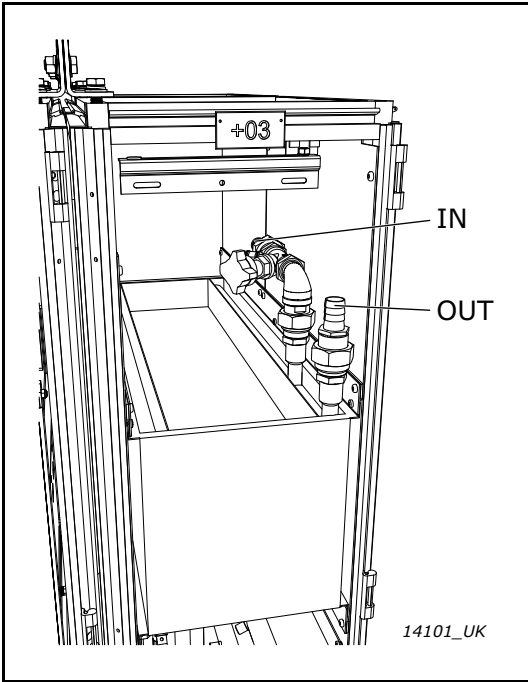

Figure 30. Fan capacitors (C)

4.3.4 INTERNAL COOLER

1	Remove the cabinet fans (see Chapter 4.3.3).
2	<p>Close the coolant supply to and from the internal cooler. The taps (-FVL01 and -FVL03, see Figure 48 on page 58) are located below the cooler.</p>  <p style="text-align: center;"><i>Figure 31. Internal cooler tap locations</i></p>
3	<p>Disconnect the coolant hoses from the top of the internal cooler.</p>  <p style="text-align: center;"><i>Figure 32. Coolant hose connections</i></p>

4

Remove the eight M6x10 screws holding the internal cooler (four above and four below the cooler).

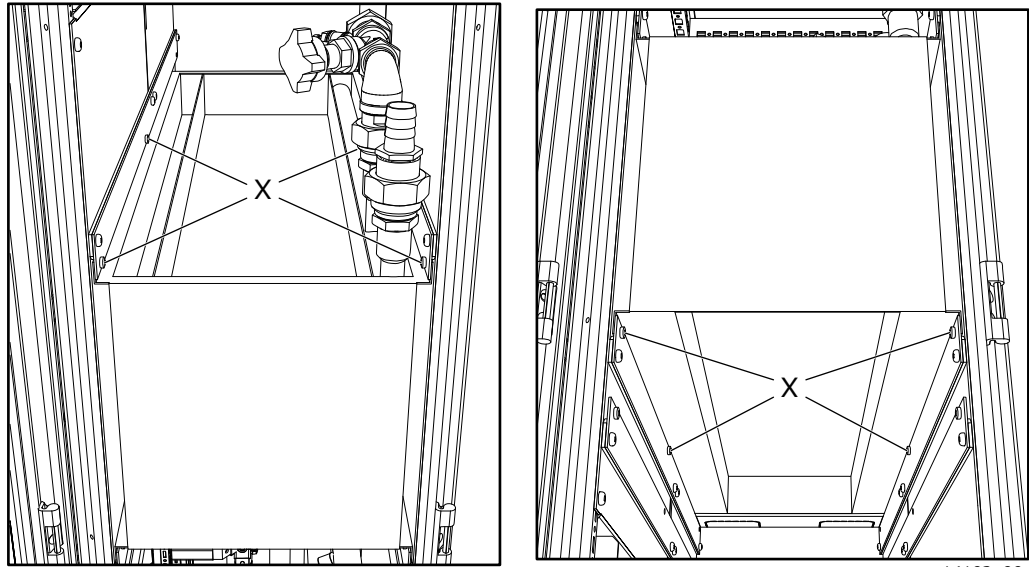

Figure 33. Internal cooler mounting screws (X) above (left) and below (right) the cooler

5

Pull out the internal cooler.

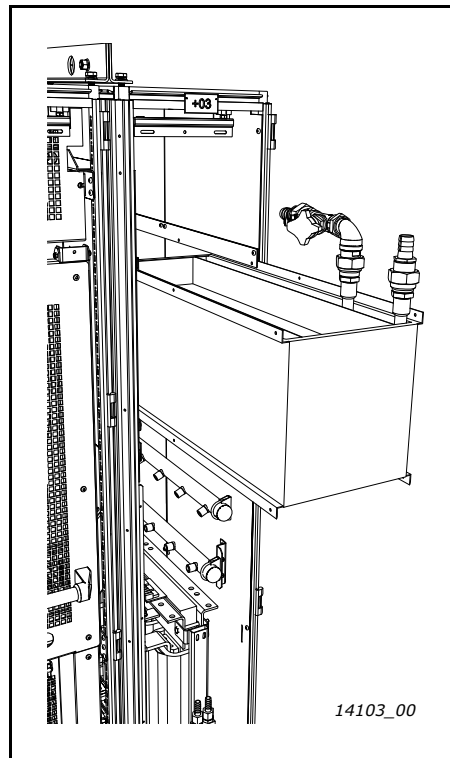

Figure 34. Pulling out the internal cooler

5. TECHNICAL INFORMATION

5.1 CONTROL AND INTERFACE

Speed and/or torque control functions are available in the drive. Speed and/or torque reference as well as command word is generated by the overriding line control system and individually transmitted to each drive either via fieldbus or hardwired signals. The drive transmits selected actual values as well as status words back to the line control system.

5.1.1 CONTROL WITHOUT SPEED FEEDBACK (OPEN LOOP)

- Speed error in steady state typically <0.5%
- Torque rise time <10 ms
- Torque error in steady state typically <3%
- Suitable also for multimotor configuration

5.1.2 CONTROL WITH SPEED FEEDBACK (CLOSED LOOP)

Full torque control at zero speed cannot be maintained without speed feedback. When a speed error of less than 0.5% or full torque control at all speeds is required, motor control based on feedback from an encoder is a necessity. This capability is incorporated into the NXP drive. In addition to the current measurement system used, the NXP drive utilizes feedback values from the encoder to determine the motor state. The enhanced microprocessor provided with the NXP drive is capable of calculations every 150 microseconds. This control can be used for applications requiring high precision, such as sectional drives.

- Speed error in steady state typically <0.01% (pulse encoder type dependent)
- Pulse encoder: 250-5000 ppr at 5, 12 or 24 V (option board dependent)
- Torque rise time <10 ms
- Torque error in steady state typically <3%

5.2 LOAD DEFINITIONS

The drives are normally selected based on the load definition shown in the drive list, where:

- n_{\min} = minimum speed [RPM], beginning of the continuous constant torque load speed range
- n_{base} = base speed [RPM], end of the continuous constant torque load speed range (and beginning of the continuous constant power load speed range)
- n_{\max} = maximum speed [RPM], end of the continuous constant power load speed range (also maximum allowed motor speed)
- $P[n_{\text{base}}]$ = base power [kW], motor shaft power at the end of the continuous constant torque load speed range (also motor shaft power of the continuous constant power load speed range)
- $T[n_{\text{base}}]$ = base torque [Nm], motor shaft torque of the continuous constant torque load speed range (also motor shaft torque at the beginning of the continuous constant power load speed range)
- OL = overload [%], short time maximum load, 1 min. / 10 min. (100% = no overload)

NOTE! Load is defined based on the information received. VACON® Plc is not responsible for verifying that the information is sufficient and accurate.

There are various possibilities to define the load curve. Below are some examples.

5.2.1 PUMP AND FAN LOAD

Set all speeds to the same value ($n_{min} = n_{base} = n_{max}$) to have the typical pump and fan curve, i.e. quadratically increasing load.

The overload is now set as starting torque and as OL at maximum speed (the overload is now defined as percent of torque at maximum speed).

The calculation of current is also here done assuming nominal flux in the motor from 0 to field weakening point (current calculation according to "optimized flux curve" is not available).

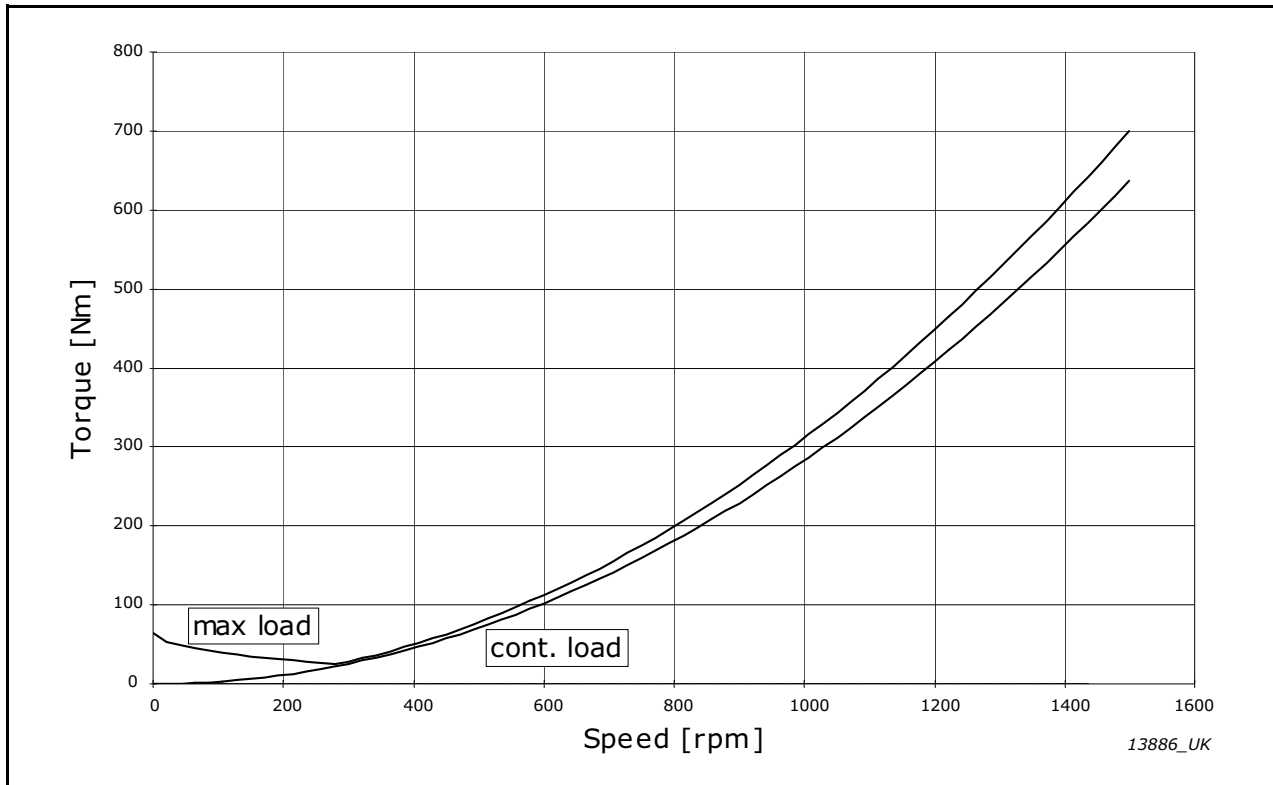

Figure 35. Example: pump and fan load

5.2.2 $OL(N_{BASE}) > OL(N_{MAX})$ FOR CONSTANT TORQUE LOAD

It is possible to set the overload at base speed smaller than the overload at maximum speed, i.e. $OL(n_{base}) < OL(n_{max})$.

This can be useful when selecting the correct AC drive for constant torque drives where the overload demand at low speeds is higher than at high speeds.

This possibility is usually used when the field weakening point is higher than base speed.

The benefit from this can be the possibility to use a size smaller AC drive.

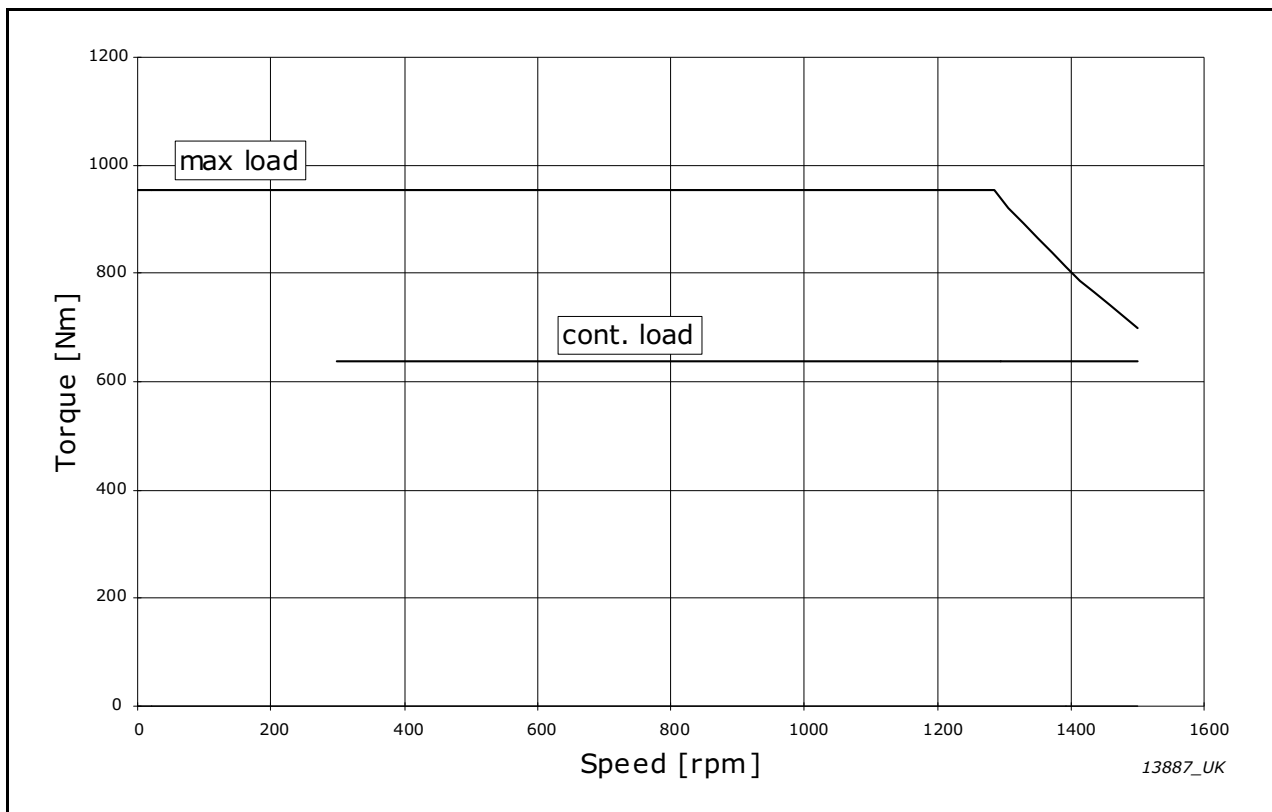

Figure 36. Example: $OL(n_{base}) > OL(n_{max})$ for constant torque load

5.2.3 STARTING TORQUE $\gg OL(n_{MAX})$ FOR CONSTANT TORQUE LOAD

It is possible to set the starting torque higher than the overload at maximum speed, i.e. $OL(n_{base}) < OL(n_{max})$.

This can be useful when selecting the correct AC drive for constant torque drives where the starting torque requirement is much higher than the maximum load requirement at maximum speed.

This possibility is usually used when the field weakening point is higher than base speed and when the starting torque is needed for a very short time.

The benefit from this can be the possibility to use a size smaller AC drive.

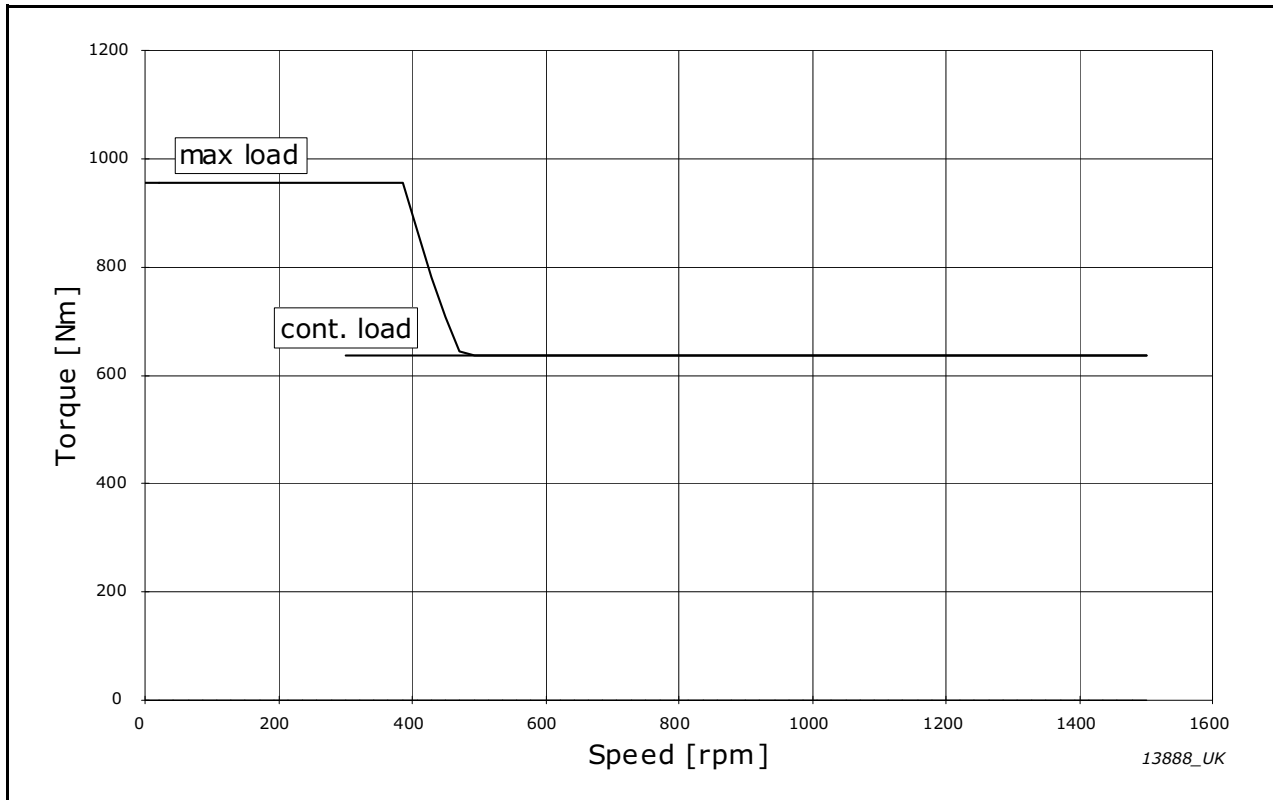

Figure 37. Example: Starting torque $\gg OL(n_{max})$ for constant torque load

5.2.4 $OL(N_{BASE}) > OL(N_{MAX})$ FOR CONSTANT POWER LOAD

Some constant power drives require less overload at max speed than at lower speeds. It is therefore possible to set the relative overload at base speed higher than the relative overload at maximum speed, i.e. $OL(n_{base}) > OL(n_{max})$.

This will decrease the size of the motor when/if thermal loadability is not the dimensioning limit.

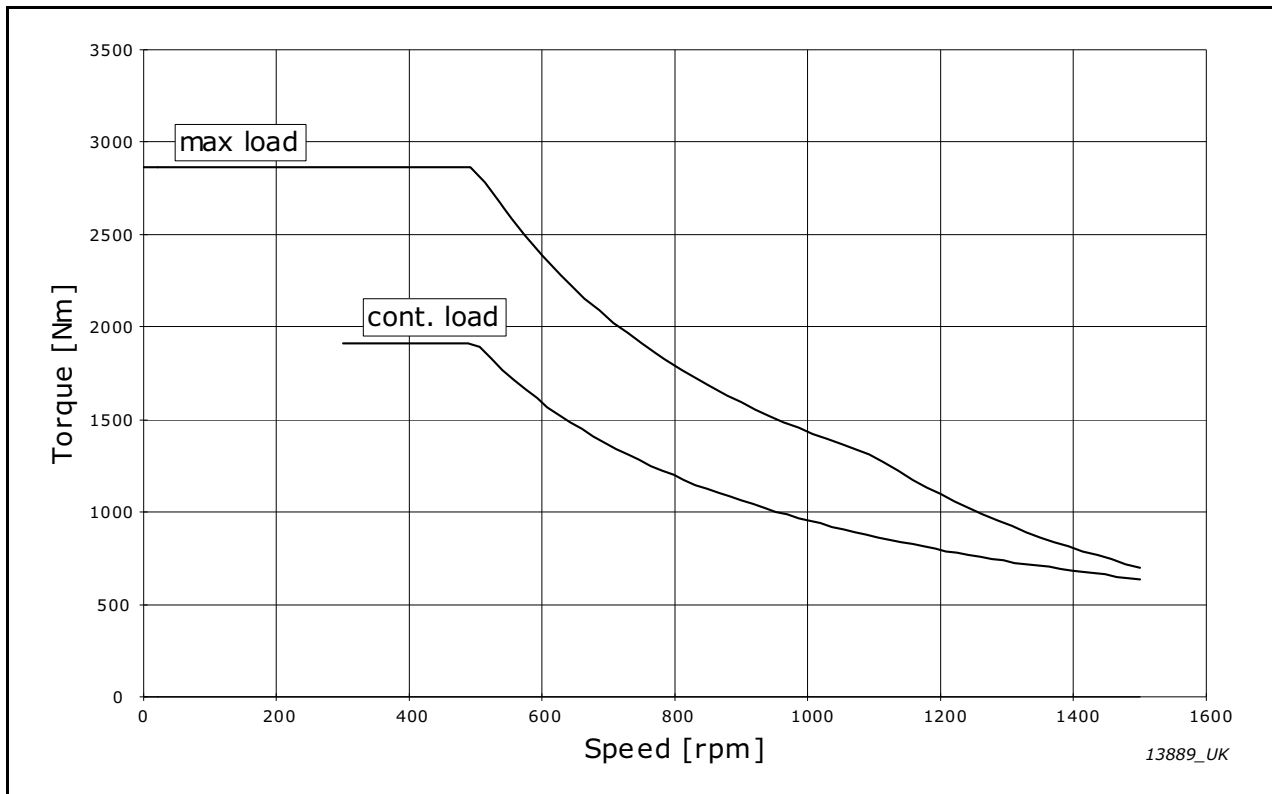

Figure 38. Example: $OL(n_{base}) > OL(n_{max})$ for constant power load

5.2.5 $OL(N_{BASE}) < OL(N_{MAX})$ FOR CONSTANT POWER LOAD

It is possible to set the overload at base speed smaller than the overload at max speed, i.e. $OL(n_{base}) < OL(n_{max})$.

This can be useful when selecting the correct motor and AC drive for constant power drives where the relative OL requirement is higher at maximum speed than the relative OL requirement at base speed.

The benefit from this can be the possibility to use a size smaller AC drive.

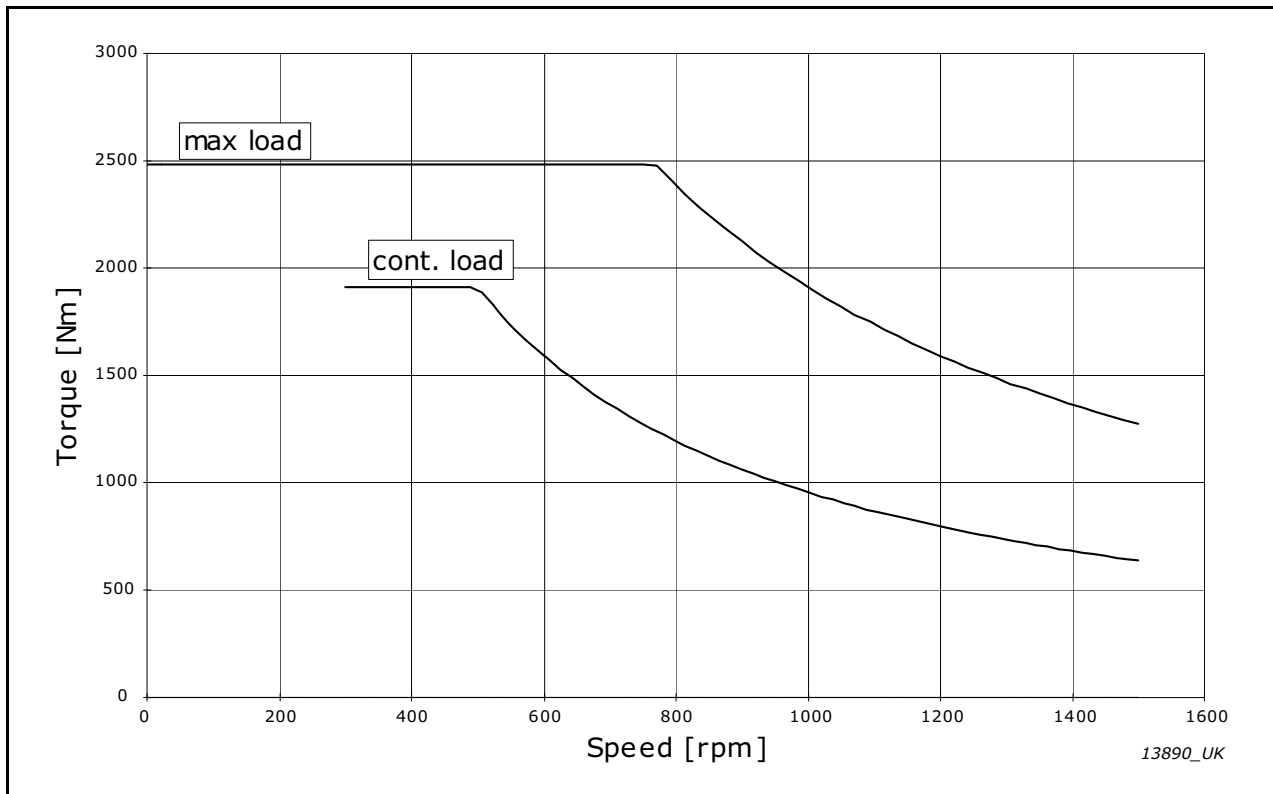

Figure 39. Example: $OL(n_{base}) < OL(n_{max})$ for constant power load

5.3 TECHNICAL SPECIFICATIONS FOR VACON® NXP LIQUID COOLED DRIVES

Table 9. Technical specifications

Mains connection	Input voltage U_{in}	NX_5: 400-500V _{AC} (-10%...+10%); 465-800V _{DC} (-0%...+0%) NX_6: 525-690V _{AC} (-10%...+10%); 640-1100V _{DC} (-0%...+0%)
	Input frequency f_{in}	45-66 Hz
	Connection to mains	Once per minute or less
	DC bank capacitance	Voltage class 500V: 32400 µF Voltage class 690 V: 14400 µF
Supply network	Networks	TN, TT, IT
	Short circuit current	Maximum short circuit current has to be <100kA
Motor connection	Output voltage U_{out}	0 - U_{in}
	Continuous output current	Rated current at nominal inflow cooling water temperature according to dimensioning charts.
	Output frequency	0-320Hz (standard); 7200Hz (special software)
Control characteristics	Frequency resolution	Application dependent
	Control method	Frequency control U/f Open Loop Sensorless Vector Control Closed Loop Vector Control
	Switching frequency	NX_5: Up to and including NX_0061: 1-16kHz; Factory default 10kHz From NX_0072: 1-6kHz; Factory default 3.6kHz (1-10kHz with special application) NX_6: 1-6kHz; Factory default 1.5kHz NOTE! Derating required if higher switching frequency than the default is used! NOTE! DriveSynch paralleling concept: Recommended minimum switching frequency for open loop control 1.7kHz and closed loop control 2.5kHz. Maximum switching frequency 3.6kHz.
	Frequency reference	
	Analogue input	Resolution 0.1% (10-bit), accuracy ±1%
	Panel reference	Resolution 0.01Hz
	Field weakening point	8-320Hz
	Acceleration time	0.1-3000 sec
	Deceleration time	0.1-3000 sec
	Braking torque	DC brake: 30% * TN (without brake option)

Table 9. Technical specifications

Ambient conditions	Ambient operating temperature	-10°C (no frost)...+50°C (at I _{th}) The NXP Liquid Cooled drives must be used in a heated indoor controlled environment.
	Installation temperature	0...+70°C
	Storage temperature	-40°C...+70°C; No liquid in heatsink under 0°C
	Relative humidity	5 to 96% RH, non-condensing, no dripping water
	Air quality: - chemical vapours - mechanical particles	IEC 60721-3-3, unit in operation, class 3C2 IEC 60721-3-3, unit in operation, class 3S2 (no conductive dust allowed) No corrosive gases
	Altitude	NX_5: (380-500V): max. 3000m (in case network is not corner grounded) NX_6: max. 2000m. For further requirements, contact factory 100-% load capacity (no derating) up to 1000m; above 1000m derating of maximum ambient operating temperature by 0.5°C per each 100m is required.
	Vibration EN50178, EN60068-2-6	5-150Hz Displacement amplitude 0.25 mm (peak) at 3-31Hz Max. acceleration amplitude 1G at 31-150Hz
	Shock EN50178, EN60068-2-27	UPS Drop Test (for applicable UPS weights) Storage and shipping: max 15G, 11ms (in package)
	Enclosure class	IP00/Open Frame standard in entire kW/HP range
	Pollution degree	PD2
EMC (at default settings)	Immunity	Fulfils IEC/EN 61800-3 EMC immunity requirements
	Emissions	EMC level N for TN/TT networks EMC level T for IT networks
Safety		IEC/EN 61800-5-1 (2007), CE, UL, cUL, GOST R, (see unit nameplate for more detailed approvals) IEC 60664-1 and UL840 in overvoltage category III.
	Safe Torque Off (STO) board	The drive is equipped with VACON® OPTAF board for prevention of torque on motor shaft. Standards: prEN ISO 13849-1 (2004), EN ISO 13849-2 (2003), EN 60079-14 (1997), EN 954-1 (1996), cat. 3 (hardware disable); IEC 61508-3(2001), prEN 50495 (2006). See manual UD01066 for detailed information.

Table 9. Technical specifications

Control connections (apply to boards OPT-A1, OPT-A2 and OPT-A3)	Analogue input voltage	0...+10V, $R_i = 200k\Omega$, (-10V...+10V joystick control) Resolution 0.1%, accuracy $\pm 1\%$
	Analogue input current	0(4)-20mA, $R_i = 250\Omega$ differential
	Digital inputs (6)	Positive or negative logic; 18-24V _{DC}
	Auxiliary voltage	+24V, $\pm 10\%$, max volt. ripple < 100mVrms; max. 250mA Dimensioning: max. 1000mA/control box 1A external fuse required (no internal short-circuit protection on the control board)
	Output reference voltage	+10V, +3%, max. load 10mA
	Analogue output	0(4)-20mA; R_L max. 500 Ω ; Resolution 10 bit; Accuracy $\pm 2\%$
	Digital outputs	Open collector output, 50mA/48V
	Relay outputs	2 programmable change-over relay outputs Switching capacity: 24V _{DC} /8A, 250V _{AC} /8A, 125V _{DC} /0.4A Min. switching load: 5V/10mA
Protections	Overvoltage trip limit	NX_5: 911V _{DC} NX_6: 1258V _{DC}
	Undervoltage trip limit	NX_5: 333V _{DC} NX_6: 461V _{DC}
	Earth fault protection	In case of earth fault in motor or motor cable, only the AC drive is protected.
	Mains supervision	Trips if any of the input phases is missing (AC drives only).
	Motor phase supervision	Trips if any of the output phases is missing.
	Unit over temperature protection	Alarm limit: 65°C (heatsink); 75°C (circuit boards). Trip limit: 70°C (heatsink); 85°C (circuit boards).
	Overcurrent protection	Yes
	Motor overload protection	Yes Motor overload protection provided at 110% of full motor load current.
	Motor stall protection	Yes
	Motor underload protection	Yes
	Short-circuit protection of +24 V and +10 V reference voltages	Yes

Table 9. Technical specifications

Liquid cooling	Allowed cooling agents	Drinking water. Water-glycol mixture. See specifications in user manual
	Volume	See user manual
	Temperature of cooling agent	0-35°C (I_{th})(input); 35-55°C: derating required Max. temperature rise during circulation max. 5°C No condensation allowed
	Cooling agent flow rates	See user manual
	System max. working pressure	6 bar
	System max. peak pressure	30 bar
	Pressure loss (at nom. flow)	Varies according to size. See user manual

6. SUPPLIED DOCUMENTATION

VACON® delivers technical documentation for the switchgear assembled AC drives according to VACON Plc's design standard. The documentation is provided in english.

VACON Plc's scope of supply regarding documentation does not include:

- Special requirements
- Delivery specific requirements
- Customer specific requirements (e.g. marking, naming, coding etc.)

Table 10. Supplied documentation

Document type	Electronic format	Paper copies
Cable connection table	dwg, dxf or pdf	3 sets
Parts list	dwg, dxf or pdf	3 sets
Wiring list	dwg, dxf or pdf	3 sets
Circuit diagram	dwg, dxf or pdf	3 sets
Switchgear layout drawing	dwg, dxf or pdf	3 sets
Device layout drawing	dwg, dxf or pdf	3 sets
VACON® manuals (as applicable)	pdf	3 sets

6.1 DOCUMENTATION EXAMPLES

6.1.1 CABLE CONNECTION TABLE

LINE	FROM	CABLE	TERMINAL	TERM. TYPE	POS.	TO	LINE	FROM	CABLE	TERMINAL	TERM. TYPE	POS.	TO
1							40				WDU 25	10/7	
2	+02-MT1 : 3	+01-W1.4 : 2	+01-X1 : 2	WDK 2.5	9/3	+01-U1 : 2	41	+01-X2 : 1 : 2		TE	WDU 25	10/7	+01-U2.B : 1
3	+01-X1 : 4			WDK 2.5	9/4	+01-U1 : 3	42			21	WDU 25	10/7	+01-U2.B : 2
4	+02-MT1 : 3	+01-W1.4 : 3	+01-X1 : 3	WDK 2.5	9/4	+01-U1 : 4	43	+01-X2 : 1 : 3		22	WDU 25	10/7	+01-U2.B : 3
5	+01-X1 : 6			WDK 2.5	9/4	+01-U1 : 5	44	+01-X2 : 1 : 4		23	WDU 25	10/7	+01-U2.B : 4
6	+01-K8 : 21			WDK 2.5	9/4	+01-U1 : 6	45	+01-X2 : 2 : 6		24	WDU 25	10/8	+01-U2.B : 28
7	+01-X1 : 10			WDK 2.5	9/4	+01-U1 : 7	46	+01-X2 : 2 : 5		25	WDU 25	10/8	+01-U2.B : 29
8	+01-XQ1 : 13			WDK 2.5	9/4	+01-U1 : 8	47			TE	WDU 25	10/1	
9	+02-XL2 : 6			WDK 2.5	9/5	+01-U1 : 9	48			+01-X3 : TE	WDU 25	11/1	
10	+01-K1 : 12			WDK 2.5	9/5	+01-U1 : 10	49			1	WDU 25	11/1	+01-U2.C : 1
11	+01-X1 : 16			WDK 2.5	9/5	+01-U1 : 11	50			2	WDU 25	11/1	+01-U2.C : 2
12	+01-K6 : 31			WDK 2.5	9/5	+01-U1 : 12	51			3	WDU 25	11/1	+01-U2.C : 3
13				WDK 2.5	9/5	+01-U1 : 13	52			4	WDU 25	11/1	+01-U2.C : 4
14	+01-K6 : 34			WDK 2.5	9/5	+01-U1 : 14	53			5	WDU 25	11/1	+01-U2.C : 5
15	+01-TVA : 2			WDK 2.5	9/6	+01-U1 : 15	54			6	WDU 25	11/1	+01-U2.C : 6
16	+01-K8 : 24			WDK 2.5	9/6	+01-U1 : 16	55			7	WDU 25	11/2	+01-U2.C : 7
17	+01-X1 : 10			WDK 2.5	9/6	+01-U1 : 17	56			8	WDU 25	11/2	+01-U2.C : 8
18				WDK 2.5	9/6		57			9	WDU 25	11/2	+01-U2.C : 9
19				WDU 2.5	10/1	+01-U2.A : 1	58			10	WDU 25	11/2	+01-U2.C : 10
20				WDU 2.5	10/1	+01-U2.A : 2	59			+01-X4 : 1	WDU 25	5/1	+01-PS2 : (+)
21				WDU 2.5	10/1	+01-U2.A : 3	60			2	WDU 25	5/1	+01-PS2 : (-)
22				WDU 2.5	10/1	+01-U2.A : 4	61			3	WDU 25	5/2	+01-K1 : 1 : 4
23				WDU 2.5	10/1	+01-U2.A : 5	62			4	WDU 25	5/2	+01-K1 : 1 : 1
24	+01-X4 : 7			WDU 2.5	10/1	+01-U2.A : 6	63			5	WDU 25	5/3	+01-K2 : 1 : 4
25	+01-X2 : 11			WDU 2.5	10/1	+01-U2.A : 7	64			6	WDU 25	5/3	+01-K2 : 1 : 1
26	+01-X4 : 8			WDU 2.5	10/2	+01-U2.A : 8	65			7	WDU 25	10/3	+01-K8 : 1 : 1
27	+01-X4 : 9			WDU 2.5	10/2	+01-U2.A : 9	66			8	WDU 25	10/3	+01-X2 : 8
28	+01-X2 : 2			WDU 2.5	10/2	+01-U2.A : 10	67			9	WDU 25	10/3	+01-X2 : 9
29	+01-X2 : 17			WDU 2.5	10/2	+01-U2.A : 11	68			10	WDU 25	10/10	+01-K5 : 1 : 2
30	+01-X2 : 11			WDU 2.5	10/2	+01-U2.A : 12	69			11	WDU 25	10/10	+01-K5 : 1 : 1
31	+01-X2 : 24			WDU 2.5	10/2	+01-U2.A : 13	70	-X1 : 1 : 16		12	WDU 25	10/5	+01-K8 : 1 : 4
32	+01-X4 : 13			WDU 2.5	10/3	+01-U2.A : 14	71	-X1 : 1 : 17		13	WDU 25	10/5	+01-X2 : 1 : 4
33				WDU 2.5	10/3	+01-U2.A : 15							
34				WDU 2.5	10/3	+01-U2.A : 16							
35	+01-X2 : 11			WDU 2.5	10/3	+01-U2.A : 17							
36				WDU 2.5	10/3	+01-U2.A : 18							
37				WDU 2.5	10/3	+01-U2.A : 19							
38				WDU 2.5	10/3	+01-U2.A : 20							
39				WDU 2.5	10/3								

Figure 40. Example: Cable connection table

6.1.2 PARTS LIST

LINE	NAME (QTY)	ARTICLE NO.	DESCRIPTION	MANUF.	POS.	LINE	NAME (QTY)	ARTICLE NO.	DESCRIPTION	MANUF.	POS.
1	+01 -C	PHE4301600330N	Capacitor PHE450, 1600V, 330nF	Rifa	6/8	21	+01 -F56 (3)	W220819J	Fuse W220819J, 32A, 14k51 mm	Mersen	6/4
2	+01 -C1	19774	1640A LCL filter capacitors, 3x68uF	Trafolek	2/1	22	+01 -F56	Y209896	Fuse holder Y209896 3P 50A, 14k51, 1000V	Mersen	6/4
3	+01 -D1	VU082-16N07	Diode bridge 3P, VU082-16N07	IXYS	6/8	23	+01 -F57	E210109	Handle ITC 32-125 A	Mersen	6/7
4	+01 -F1.1	G239160	Fuse 11URD84TQF2400, 2400A, 1100V	Mersen	2/2	24	+01	L207493D	Aux. contacts L207493D, 1NO	Mersen	7/4
5	+01 -F1.2	G239160	Fuse 11URD84TQF2400, 2400A, 1100V	Mersen	2/2	25	+01 -F57 (3)	W220819J	Fuse W220819J, 32A, 14k51 mm	Mersen	6/7
6	+01 -F1.3	G239160	Fuse 11URD84TQF2400, 2400A, 1100V	Mersen	2/2	26	+01 -F57	Y209896	Fuse holder Y209896 3P 50A, 14k51, 1000V	Mersen	6/8
7	+01 -F50 (3)	6697	Fuse PV10 gG 8A, 10x38mm	OEZ	4/2	27	+01 -F510	179200 3, 15A	Fuse 20mm sand-filled, 3, 15A	Siba	5/1
8	+01 -F50	31113	Fuse holder AES 3P 32A	Wohner	4/2	28	+01	10113000	Holder for 20mm fuse with LED, W516/LD, 10-36V	Weidmuller	5/1
9	+01 -F51	179200 1A	Fuse 20mm sand-filled, 1A	Siba	5/5	29	+01 -F511	179200 2A	Fuse 20mm sand-filled, 2A	Siba	5/2
10	+01	10113000	Holder for 20mm fuse with LED, W516/LD, 10-36V	Weidmuller	5/5	30	+01	10113000	Holder for 20mm fuse with LED, W516/LD, 10-36V	Weidmuller	5/2
11	+01 -F52	179200 1A	Fuse 20mm sand-filled, 1A	Siba	5/6	31	+01 -HL1	SEL2D230VWHITE	LED, d=22mm, 230VAC, white	S.E.L.	4/5
12	+01	10113000	Holder for 20mm fuse with LED, W516/LD, 10-36V	Weidmuller	5/6	32	+01 -HL2	SEL2D230VRED	LED, d=22mm, 230VAC, red	S.E.L.	10/7
13	+01 -F53	179200 1A	Fuse 20mm sand-filled, 1A	Siba	5/7	33	+01 -K1	38517.024.0050	PLC relay 24VDC, 1CO, 6A	Finder	5/4
14	+01	10113000	Holder for 20mm fuse with LED, W516/LD, 10-36V	Weidmuller	5/7	34	+01 -K2	38517.024.0050	PLC relay 24VDC, 1CO, 6A	Finder	5/4
15	+01 -F54	179200 1A	Fuse 20mm sand-filled, 1A	Siba	5/7	35	+01 -K3.1	4052.8.230	Relay 230VAC, 2xCO, 8A	Finder	7/7
16	+01	10113000	Holder for 20mm fuse with LED, W516/LD, 10-36V	Weidmuller	5/8	36	+01	9575	Base for relay 2 contacts, DIN	Finder	
17	+01 -F55	179200 1A	Fuse 20mm sand-filled, 1A	Siba	5/8	37	+01 -K3.2	4052.8.230	Relay 230VAC, 2xCO, 8A	Finder	7/8
18	+01	10113000	Holder for 20mm fuse with LED, W516/LD, 10-36V	Weidmuller	5/8	38	+01	9575	Base for relay 2 contacts, DIN	Finder	
19	+01 -F56	E210109	Handle ITC 32-125 A	Mersen	6/4	39	+01 -K4	4052.8.230	Relay 230VAC, 2xCO, 8A	Finder	7/9
20	+01	L207493D	Aux. contacts L207493D, 1NO	Mersen	7/4	40	+01	9575	Base for relay 2 contacts, DIN	Finder	

REV. DATE		REASONS FOR ISSUING	
14105_00			

FC SUPPLIER		VACON® DRIVEN BY DRIVES	
TITLE		COMPONENT LIST	
PROJECT NAME		CUSTOMER ID	
RFPAS ID		RFS000419	
PAGE		PAGE	
PAGES IN CHAPTER		PAGES IN CHAPTER	
14		14	

Figure 41. Example: Parts list

6.1.3 WIRING LIST

LINE	FROM	CABLE	CABLE TYPE	POS.	TO	LINE	FROM	CABLE	CABLE TYPE	POS.	TO
1						36	+01-U2A :1			10/1	+01-X2 :1
2						37	+01-U2A :2	+01-IW2.1 1	12x0.75mm2	10/1	+01-X2 :2
3						38	+01-U2A :3	2		10/1	+01-X2 :3
4						39	+01-U2A :4	3		10/1	+01-X2 :4
5	L1 :1					40	+01-U2A :5	4		10/1	+01-X2 :5
6	L2 :1	4x(3x240mm2+SCR)		2/2		41	+01-U2A :6	5		10/1	+01-X2 :6
7	L3 :1	2		2/2		42	+01-U2A :7	6		10/1	+01-X2 :7
8	PE :1	3		2/2		43	+01-U2A :8	7		10/2	+01-X2 :8
9	U :1	5		2/2		44	+01-U2A :9	8		10/2	+01-X2 :9
10	V :1	1		2/7		45	+01-U2A :10	9		10/2	+01-X2 :10
11	W :1	2		2/8		46	+01-U2A :11	10		10/2	+01-X2 :11
12	PE :1	3		2/8		47	+01-U2A :12	+01-IW2.2 1		10/2	+01-X2 :12
13	+01-U1 :2					48	+01-U2A :13	2		10/2	+01-X2 :13
14	+01-U1 :3	+01-IW1.1 1	12x0.75mm2	9/4	+01-X1 :1	49	+01-U2A :14	3		10/2	+01-X2 :14
15	+01-U1 :4	2		9/4	+01-X1 :2	50	+01-U2A :15	4		10/3	+01-X2 :15
16	+01-U1 :5	3		9/4	+01-X1 :3	51	+01-U2A :16	5		10/3	+01-X2 :16
17	+01-U1 :6	4		9/4	+01-X1 :4	52	+01-U2A :17	6		10/3	+01-X2 :17
18	+01-U1 :7	5		9/4	+01-X1 :5	53	+01-U2A :18	7		10/3	+01-X2 :18
19	+01-U1 :8	6		9/4	+01-X1 :6	54	+01-U2A :19	8		10/3	+01-X2 :19
20	+01-U1 :9	7		9/5	+01-X1 :7	55	+01-U2A :20	9		10/3	+01-X2 :20
21	+01-U1 :10	8		9/5	+01-X1 :8	56	+01-U2B :1	+01-IW2.3 1	7x0.75mm2	10/7	+01-X2 :21
22	+01-U1 :11	9		9/5	+01-X1 :9	57	+01-U2B :2	2		10/7	+01-X2 :22
23	+01-U1 :12	+01-IW1.2 1	7x0.75mm2	9/5	+01-X1 :10	58	+01-U2B :3	3		10/7	+01-X2 :23
24	+01-U1 :13	2		9/5	+01-X1 :11	59	+01-U2B :4	4		10/7	+01-X2 :24
25	+01-U1 :14	3		9/5	+01-X1 :12	60	+01-U2B :28	5		10/8	+01-X2 :25
26	+01-U1 :15	4		9/5	+01-X1 :13	61	+01-U2B :29	6		10/8	+01-X2 :26
27	+01-U1 :16	5		9/6	+01-X1 :14	62	+01-U2B :22	+01-IW2.4 1	7x1.5mm2	10/8	+01-X5 :9
28	+01-U1 :17	6		9/6	+01-X1 :15	63	+01-U2B :23	2		10/8	+01-X5 :10
29	+01-U1 :22	7		9/6	+01-X1 :16	64	+01-U2B :25	3		10/8	+01-X5 :11
30	+01-U1 :23	+01-IW1.3 1	7x1.5mm2	9/9	+01-X5 :5	65	+01-U2B :26	4		10/8	+01-X5 :12
31	+01-U1 :25	2		9/9	+01-X5 :6						
32	+01-U1 :26	3		9/9	+01-X5 :7						
		4		9/9	+01-X5 :8						
33	+02-MT1 :1										
34	+02-MT1 :3	+01-IW1.4 1	7x0.75 mm2	9/1	+01-X8 :21						
35	+02-MT1 :3	2		9/1	+01-X1 :1						
		3		9/2	+01-X1 :3						

REV.	DATE	REASONS FOR ISSUING

FC SUPPLIER	TITLE	PROJECT NAME	PAGE DESIGNATION
VACON® DRIVEN BY DRIVES	CABLE LIST	CUSTOMER ID	PROJ. REVISION
		RF5000419	2013.11.25
			PAGE
			PAGES IN CHAPTER
			14

Figure 42. Example: Wiring list

6.1.4 CIRCUIT DIAGRAM

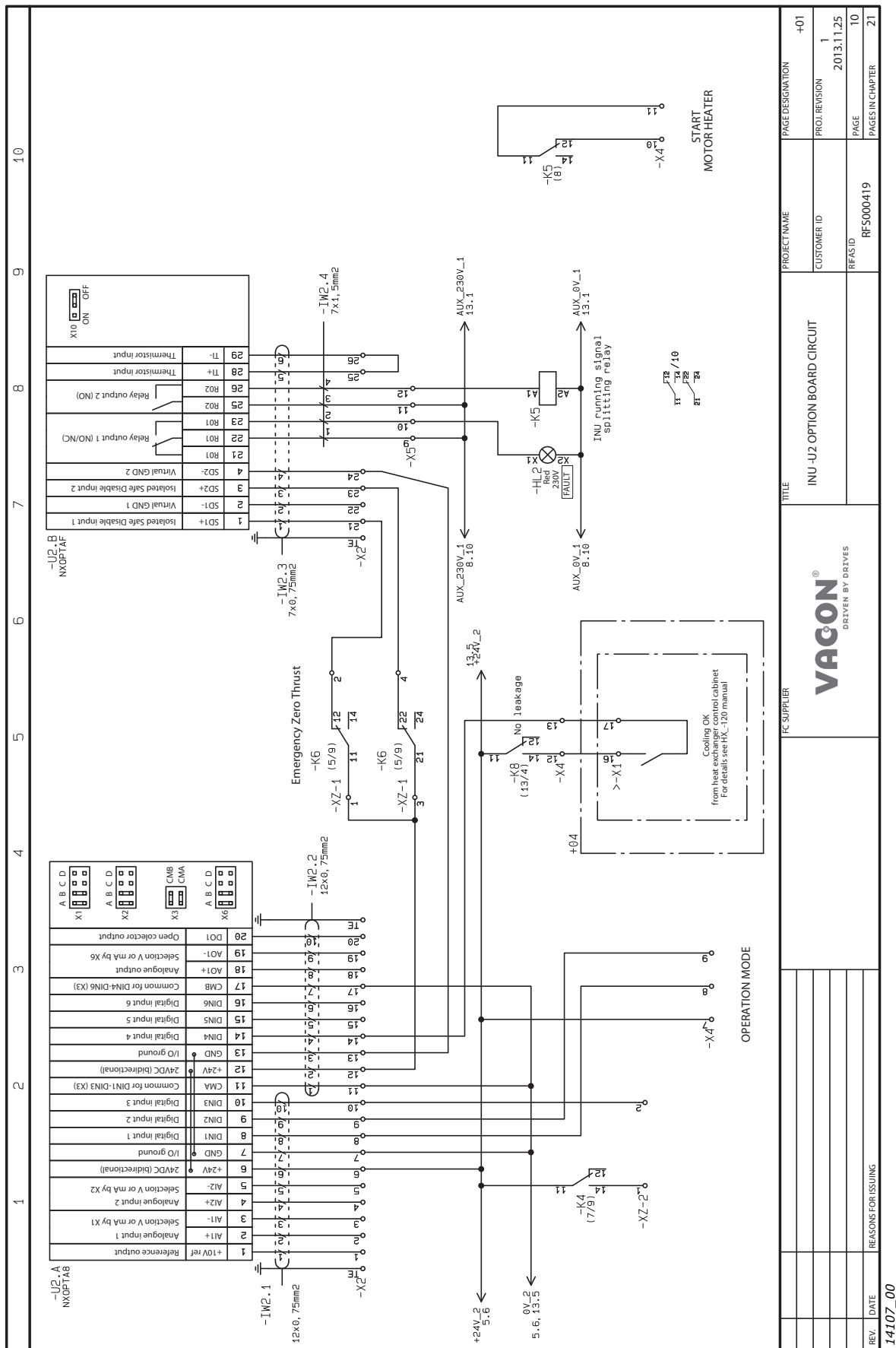

Figure 43. Example: Circuit diagram

6.1.5 SWITCHGEAR LAYOUT DRAWING

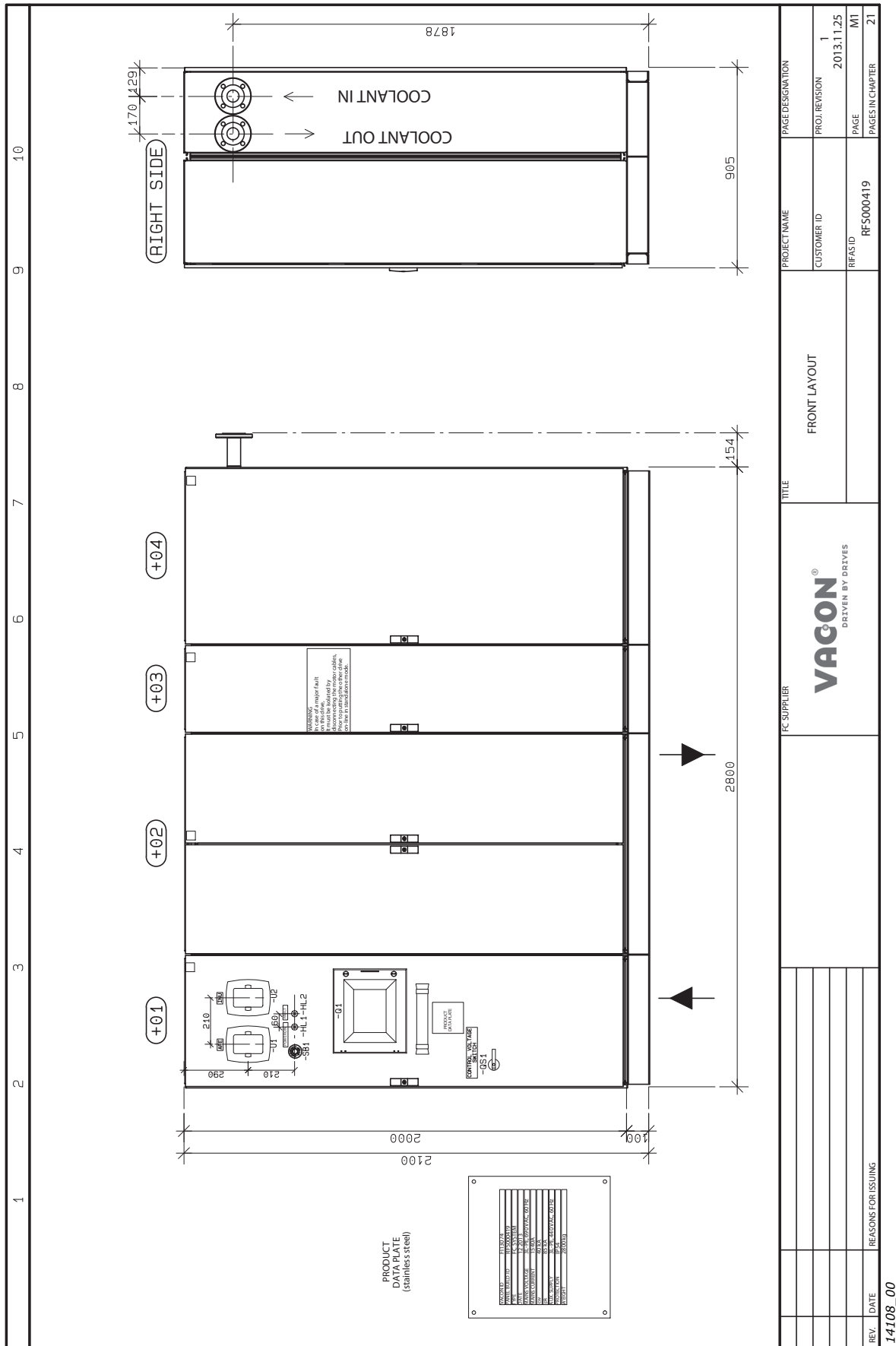

Figure 44. Example: Switchgear layout drawing

6.1.6 DEVICE LAYOUT DRAWING

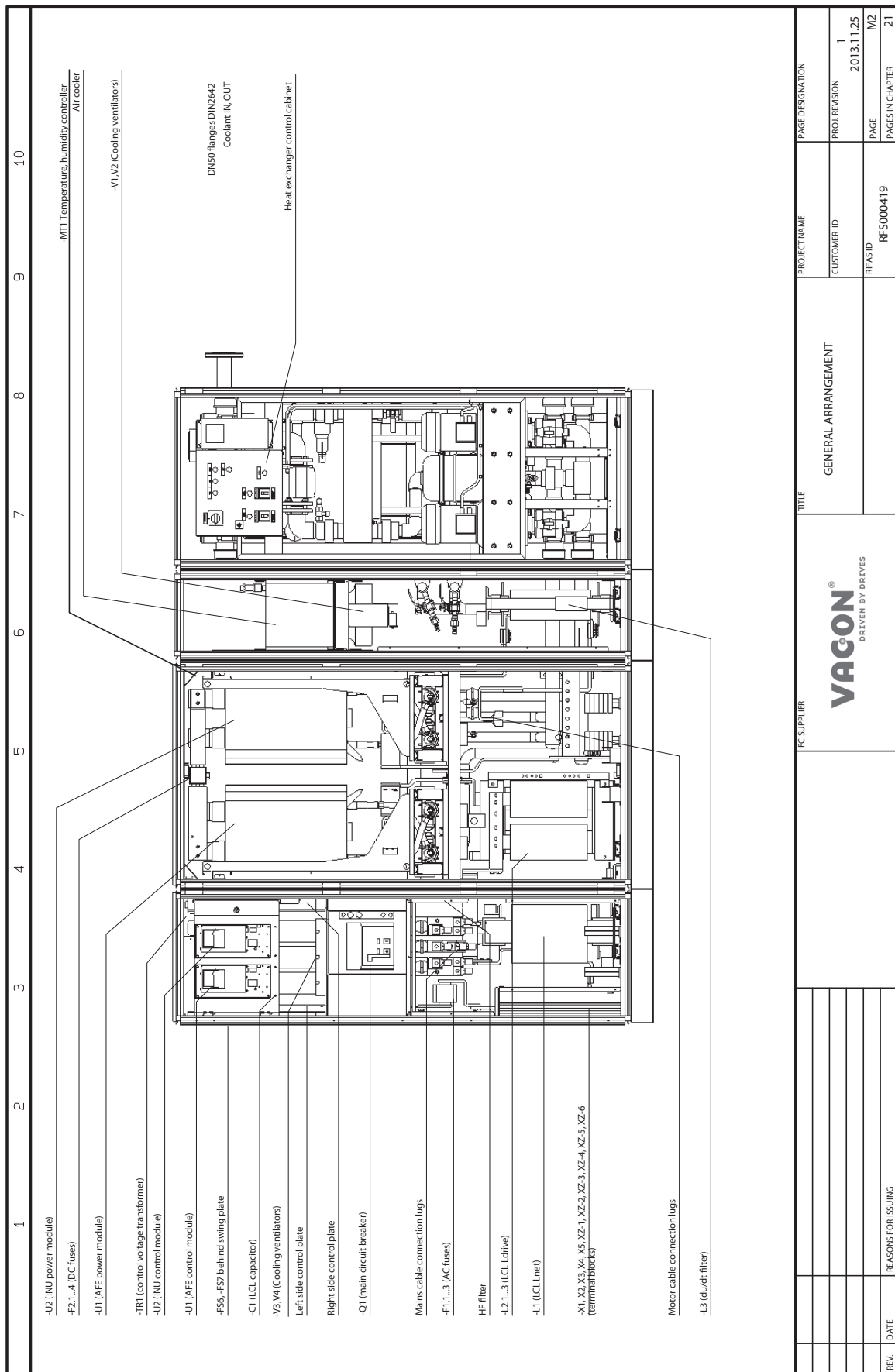

Figure 45. Example: Device layout drawing

7. APPENDIX

7.1 POWER LINE CIRCUIT DIAGRAM

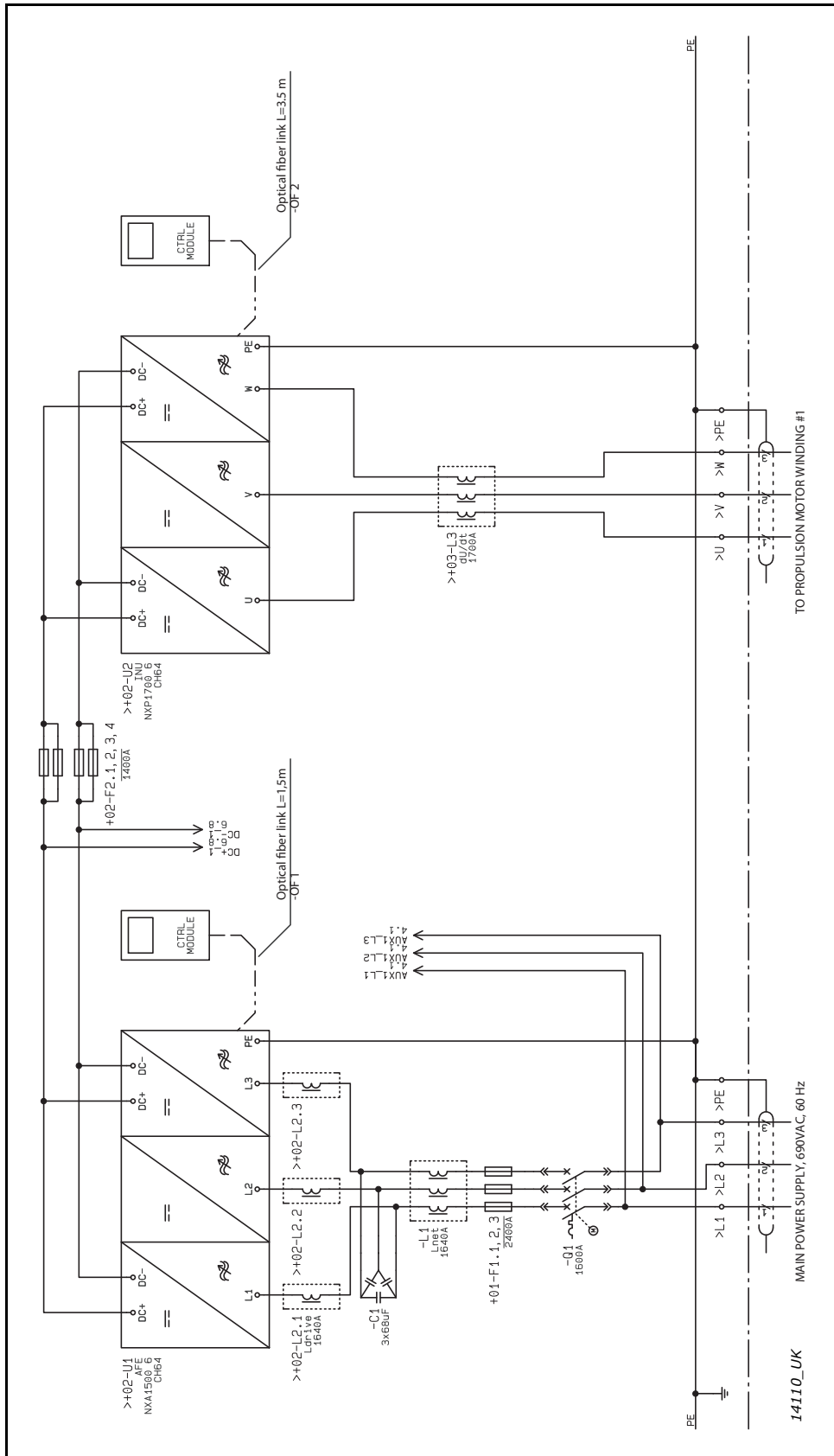

Figure 46. Power line circuit diagram, revision 1

7.2 P&ID DRAWINGS

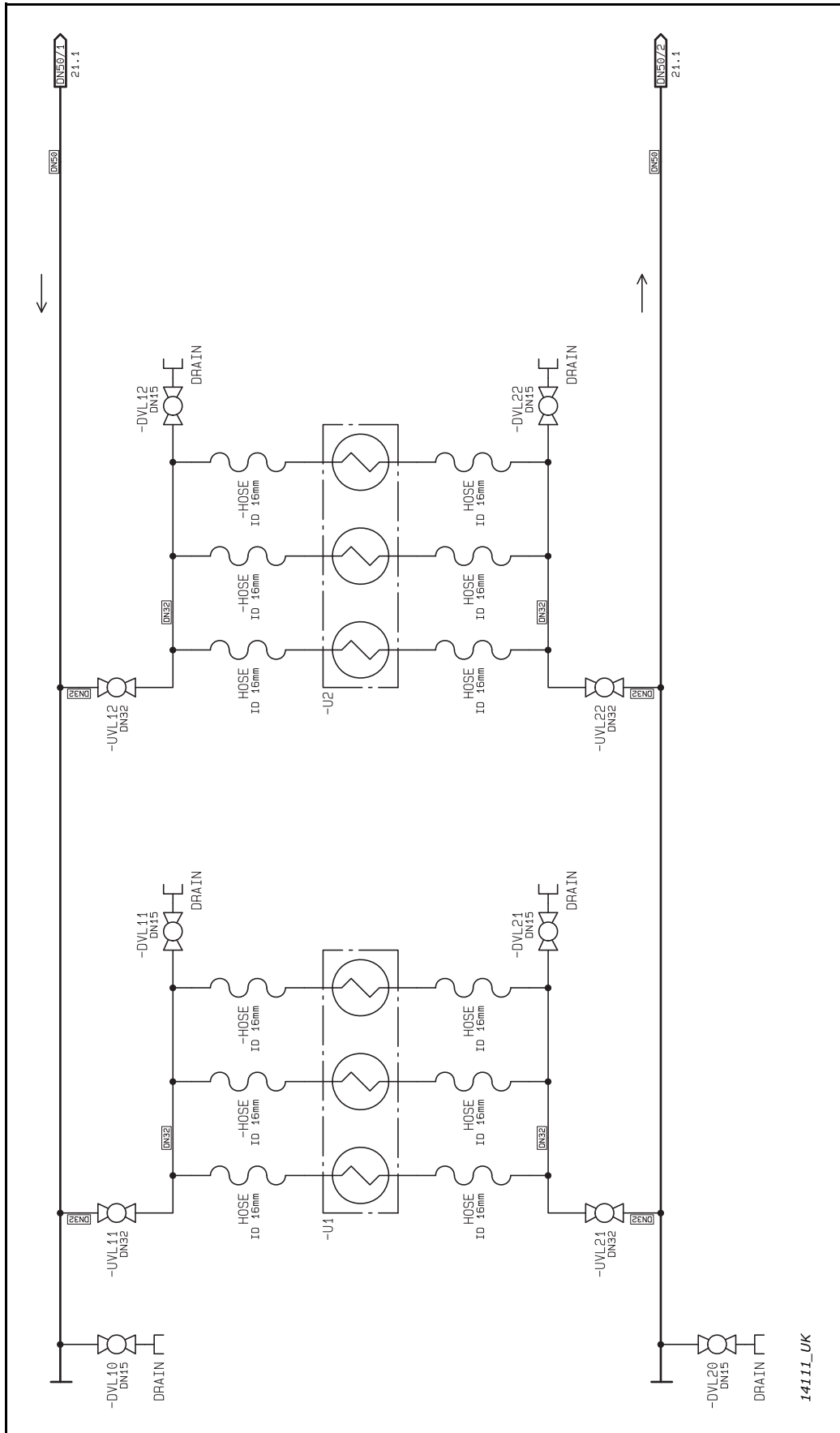

Figure 47. P&ID drawing, page 1, revision 1

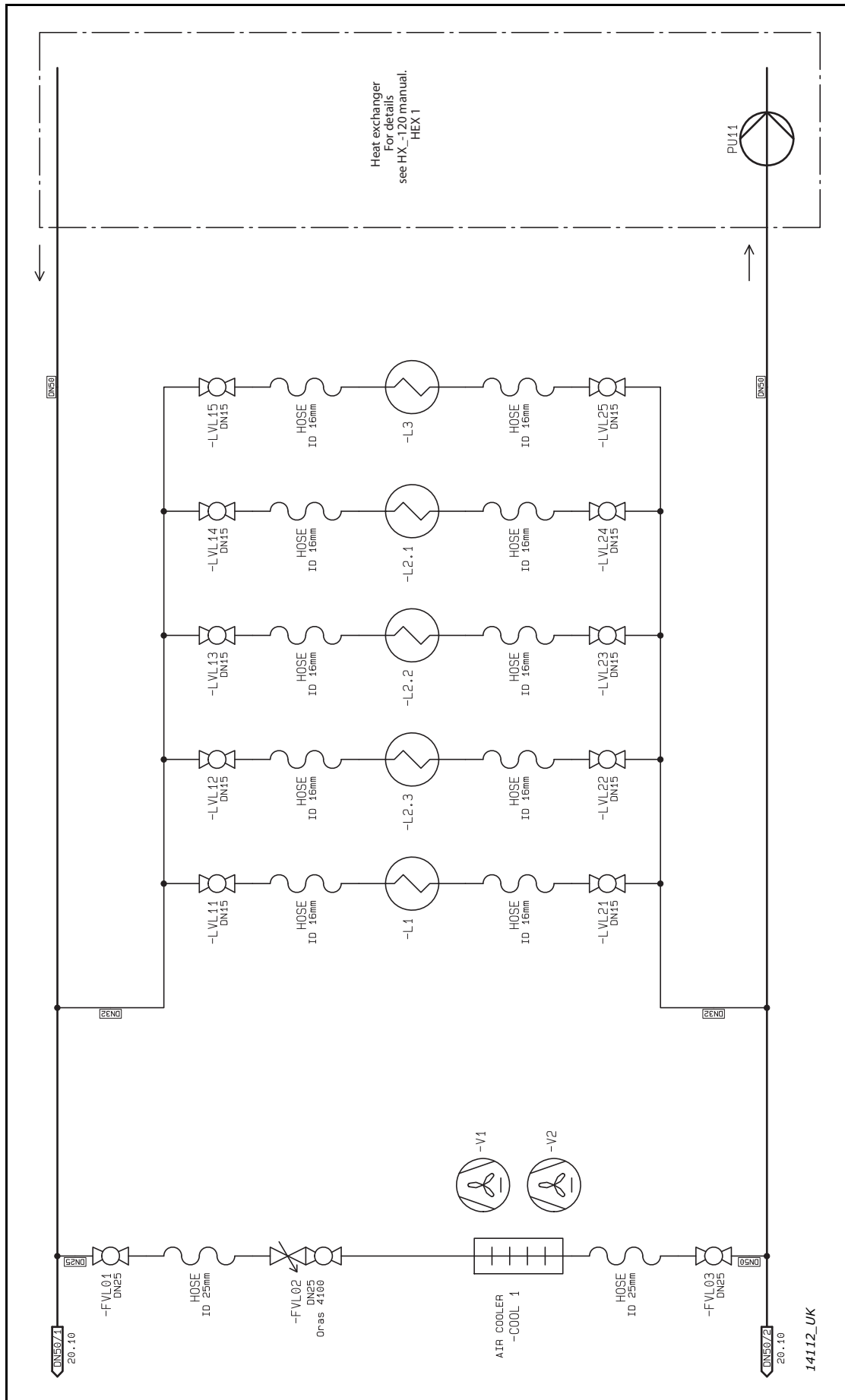

Figure 48. P&ID drawing, page 2, revision 1

VACON[®]

www.danfoss.com

Vacon Ltd
Member of the Danfoss Group
Runsorintie 7
65380 Vaasa
Finland

Document ID:



DPD01596C

Rev. C

Sales code: DOC-INSNXPLCED+DLUK