

VACON[®]
AC DRIVES

**DEVICENET OPTION BOARD OPTe7
USER MANUAL**

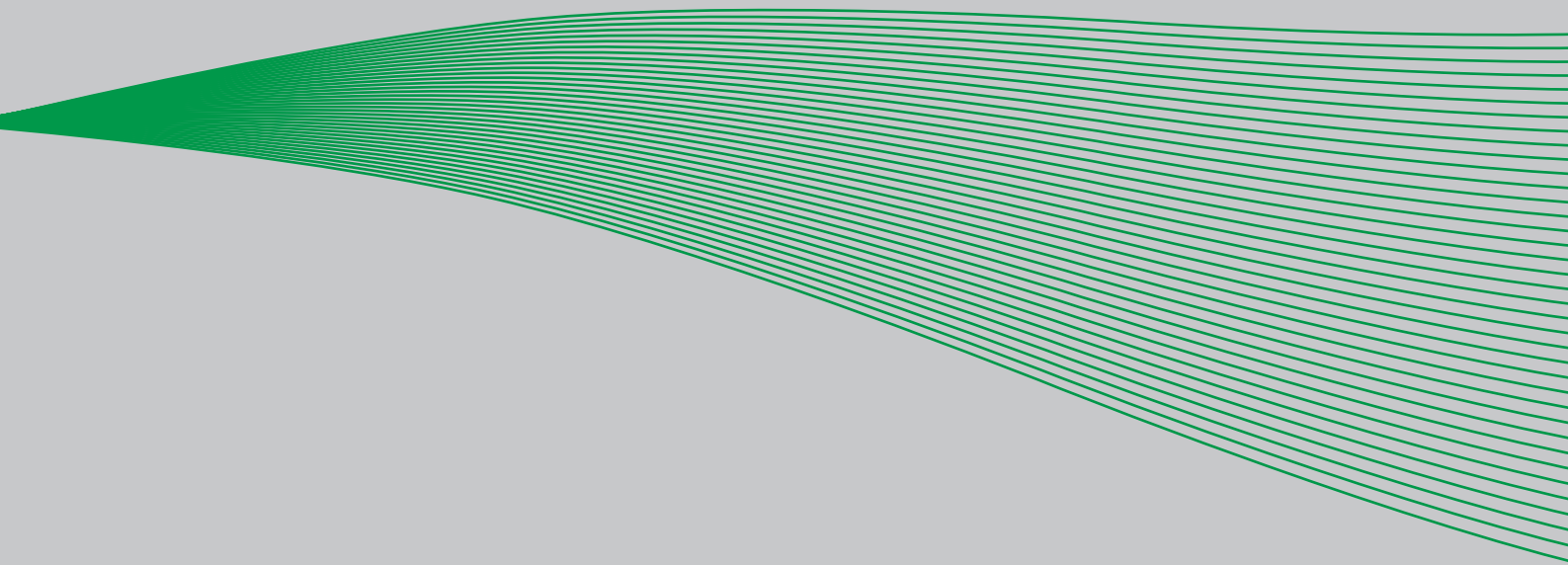

VACON[®]
DRIVEN BY DRIVES

TABLE OF CONTENTS

Document: DPD01171B

Release date : 30.01.2015

1. Safety	2
1.1 Danger.....	2
1.2 Warnings.....	3
1.3 Earthing and earth fault protection.....	4
2. DeviceNet option board OPTE7 - General	5
2.1 Overview.....	5
2.1.1 DeviceNet physical layer and media.....	5
2.2 DeviceNet protocol description.....	7
2.2.1 EDS (Electronic Data Sheet) file.....	8
3. DeviceNet option board OPTE7 - technical data	9
3.1 General.....	9
3.2 CAN cable.....	9
3.2.1 Recommended cable.....	10
4. OPTE7 layout and connections	11
4.1 Layout and connections.....	11
4.2 LED Indications.....	12
4.3 Jumpers.....	14
5. Installation	16
5.1 Installation in Vacon® 100.....	16
5.2 Prepare for use through fieldbus.....	18
5.3 Installation in Vacon® 20.....	21
5.3.1 Frames MI1, MI2, MI3.....	21
5.3.2 Frames MI4, MI5.....	24
5.4 Installation in Vacon® 20 X and 20 CP.....	28
5.5 Installation in Vacon® 100 X (Frames MM4-MM6).....	31
6. Commissioning	35
6.1 Parameter view.....	35
6.2 Monitor view.....	35
6.3 Software info view.....	36
6.4 Fieldbus parametrisation.....	36
6.4.1 Fieldbus control and basic reference selection.....	36
6.4.2 Torque control parametrisation.....	37
6.4.3 Process data mapping and default settings.....	37
7. DeciveNet interface	39
7.1 I/O messaging.....	39
7.1.1 Connection behaviour.....	39
7.1.2 Input and Output Assemblies.....	40
7.1.3 Control Supervisor Behaviour.....	49
7.2 Explicit messaging.....	51
7.2.1 Connection behaviour.....	51
8. Fault handling	52
8.1 General and additional error codes.....	53
9. Appendix A: Object dictionary	54
9.1 Implemented CIP objects.....	54
9.1.1 List of Object Classes.....	54
9.1.2 List of Services.....	55
9.1.3 Class Code 0x01 - Identity Object.....	56
9.1.4 Class Code 0x02 - Message Router Object.....	58
9.1.5 Class Code 0x03 - DeviceNet Object.....	58

9.1.6	Class Code 0x04 - Assembly Object	61
9.1.7	Class Code 0x05 - DeviceNet Connection Object	62
9.1.8	Class Code 0x28 - Motor Data Object	65
9.1.9	Class Code 0x29 - Control Supervisor Object	67
9.1.10	Class Code 0x2A - AC/DC Drive Object.....	70
9.1.11	Class Code 0xA0 - Vendor Parameter Object.....	72
10.	Appendix B: Communication attribute details.....	74
10.1	DeviceNet's use of the CAN Identifier Field	74
10.2	Connection object paths.....	74
11.	Appendix C: Fault and warning codes	76



1. SAFETY

This manual contains clearly marked cautions and warnings that are intended for your personal safety and to avoid any unintentional damage to the product or connected appliances.

Please read the information included in cautions and warnings carefully.

The cautions and warnings are marked as follows:

Table 1. Warning signs

	= DANGER! Dangerous voltage
	= WARNING or CAUTION
	= Caution! Hot surface

1.1 DANGER



The **components of the power unit are live** when the drive is connected to mains potential. Coming into contact with this voltage is **extremely dangerous** and may cause death or severe injury.



The **motor terminals U, V, W and the brake resistor terminals are live** when the AC drive is connected to mains, even if the motor is not running.



After disconnecting the AC drive from the mains, **wait** until the indicators on the keypad go out (if no keypad is attached, see the indicators on the cover). Wait 5 more minutes before doing any work on the connections of the drive. Do not open the cover before this time has expired. After expiration of this time, use a measuring equipment to absolutely ensure that no voltage is present. **Always ensure absence of voltage before starting any electrical work!**



The control I/O-terminals are isolated from the mains potential. However, the **relay outputs and other I/O-terminals may have a dangerous control voltage** present even when the AC drive is disconnected from mains.



Before connecting the AC drive to mains make sure that the front and cable covers of the drive are closed.



During a ramp stop (see the Application Manual), the motor is still generating voltage to the drive. Therefore, do not touch the components of the AC drive before the motor has completely stopped. Wait until the indicators on the keypad go out (if no keypad is attached, see the indicators on the cover). Wait additional 5 minutes before starting any work on the drive.

1.2 WARNINGS



The AC drive is meant for **fixed installations only**.



Do not perform any measurements when the AC drive is connected to the mains.



The **earth leakage current** of the AC drives exceeds 3.5mA AC. According to standard EN61800-5-1, a **reinforced protective ground connection** must be ensured. See Chapter 1.3.



If the AC drive is used as a part of a machine, the **machine manufacturer is responsible** for providing the machine with a **supply disconnecting device** (EN 60204-1).



Only **spare parts** delivered by Vacon can be used.



At power-up, power brake or fault reset **the motor will start immediately** if the start signal is active, unless the pulse control for Start/Stop logic has been selected. Furthermore, the I/O functionalities (including start inputs) may change if parameters, applications or software are changed. Disconnect, therefore, the motor if an unexpected start can cause danger.



The **motor starts automatically** after automatic fault reset if the auto restart function is activated. See the Application Manual for more detailed information.



Prior to measurements on the motor or the motor cable, disconnect the motor cable from the AC drive.



Do not touch the components on the circuit boards. Static voltage discharge may damage the components.



Check that the **EMC level** of the AC drive corresponds to the requirements of your supply network.

1.3 EARTHING AND EARTH FAULT PROTECTION



CAUTION!

The AC drive must always be earthed with an earthing conductor connected to the earthing terminal marked with

The earth leakage current of the drive exceeds 3.5mA AC. According to EN61800-5-1, one or more of the following conditions for the associated protective circuit must be satisfied:

- a) The protective conductor must have a cross-sectional area of at least 10 mm² Cu or 16 mm² Al, through its total run.
- b) Where the protective conductor has a cross-sectional area of less than 10 mm² Cu or 16 mm² Al, a second protective conductor of at least the same cross-sectional area must be provided up to a point where the protective conductor has a cross-sectional area not less than 10 mm² Cu or 16 mm² Al.
- c) Automatic disconnection of the supply in case of loss of continuity of the protective conductor.

The cross-sectional area of every protective earthing conductor which does not form part of the supply cable or cable enclosure must, in any case, be not less than:

- 2.5mm² if mechanical protection is provided or
- 4mm² if mechanical protection is not provided.

The earth fault protection inside the AC drive protects only the drive itself against earth faults in the motor or the motor cable. It is not intended for personal safety.

Due to the high capacitive currents present in the AC drive, fault current protective switches may not function properly.



Do not perform any voltage withstand tests on any part of the AC drive. There is a certain procedure according to which the tests must be performed. Ignoring this procedure can cause damage to the product.

NOTE! You can download the English and French product manuals with applicable safety, warning and caution information from www.vacon.com/downloads.

REMARQUE Vous pouvez télécharger les versions anglaise et française des manuels produit contenant l'ensemble des informations de sécurité, avertissements et mises en garde applicables sur le site www.vacon.com/downloads.

2. DEVICENET OPTION BOARD OPTE7 - GENERAL

2.1 OVERVIEW

OPTE7 is a DeviceNet option board for Vacon AC drives. It allows the AC drive to be controlled using the DeviceNet protocol. The option board implements the AC Drive device profile as defined by CIP.

The OPTE7 option board connects a drive into the DeviceNet network. There can be 64 nodes in one network. The baud rate is up to 500 kbit/s. The DeviceNet master can control and monitor the drives.

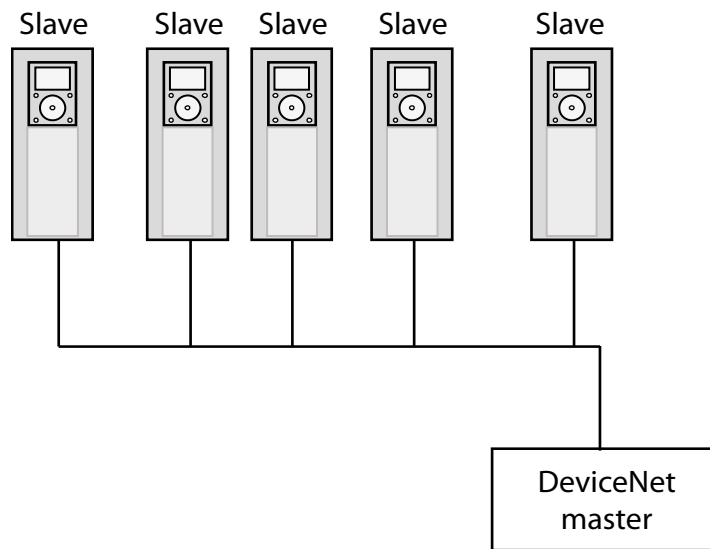

9391.emf

Figure 1. Typical DeviceNet network structure

2.1.1 DEVICENET PHYSICAL LAYER AND MEDIA

The basic trunkline-dropline topology provides separate twisted pair busses for both signal and power distribution. Thick or thin cable can be used for either trunklines or droplines. End-to-end network distance varies with data rate and cable size.

Devices can be powered directly from the bus and communicate with each other using the same cable. Nodes can be removed from or inserted to the network without powering down the network.

Power taps can be added at any point in the network which makes redundant power supplies possible. The trunkline current rating is 8 amperes. An opto-isolated design option allows externally powered devices (e.g. AC drive's starters and solenoid valves) to share the same bus cable. Other CAN-based networks allow only a single power supply (if at all) for the entire network.

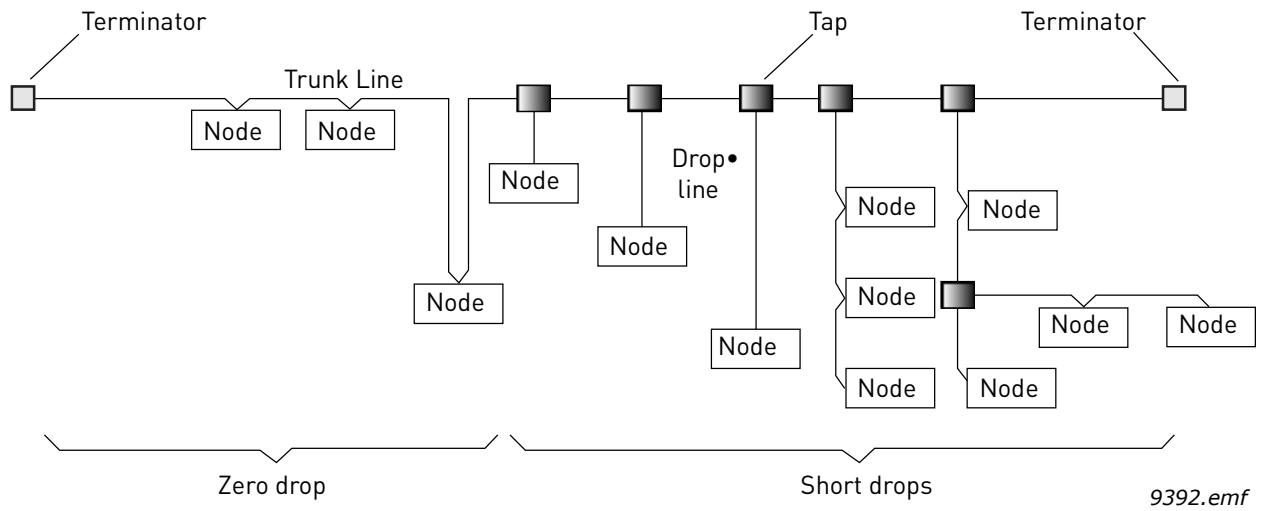

Figure 2. Thick or thin cable for either trunklines or droplines

2.2 DEVICENET PROTOCOL DESCRIPTION

DeviceNet is a communication protocol that is managed by the ODVA (Open DeviceNet Vendors Association). It uses CAN (Controller Area Network) as the backbone technology and at the higher level it implements CIP (Common Industrial Protocol). CIP is used by the following protocols:

- DeviceNet
- EtherNet/IP
- ControlNet
- CompoNet

CIP ensures high integrity/interoperability between all of these, especially from the end user perspective. CIP is object-oriented. It defines objects with its attributes and supported services. The objects can have multiple instances. Instance zero indicates object's class itself. Depending on the implemented profile, some objects are mandatory and have to be implemented. Additionally, each vendor can implement vendor-specific objects.

The following objects are implemented by the OPTE7 option board:

Table 2.

	Class	Object
Required by DeviceNet	0x01	Identity
	0x02	Message Router
	0x03	DeviceNet
	0x04	Assembly
	0x05	DeviceNet Connection
Required by Drive Profile	0x28	Motor Data
	0x29	Control Supervisor
	0x2A	AC/DC Drive
Vendor-Specific	0xA0	Vendor Parameter

Table 3.

Physical / Data link layer	CAN - Controller Area Network
Application layer	CIP - Common Industrial Protocol
Profiles	AC/DC Drives
Configuration file	EDS - Electronic Data Sheet
Baud rates	125 kbit/s, 250 kbit/s, and 500 kbit/s
Bus length	Trunk length is inversely proportional to the speed, i.e. 500, 250 and 100 meters respectively
Max nodes	64

2.2.1 EDS (ELECTRONIC DATA SHEET) FILE

EDS is a configuration file that describes the capabilities of the DeviceNet node. It can be used by the configuration tool to simplify the process of commissioning. EDS is actually a simple text file that follows the rules specified by the ODVA in the DeviceNet specification. Therefore, it could be opened and viewed with a simple text editor e.g. Notepad.

The EDS file for the OPTE7 option board can be downloaded from www.vacon.com.

3. DEVICENET OPTION BOARD OPTE7 - TECHNICAL DATA

3.1 GENERAL

Table 4. Technical data of OPTE7 option board

CAN bus electrical isolation	500 VDC	
Ambient temperature	As specified in drive specification (-10°C...40°C)	
Storing temperature	As specified in drive specification (-40°C...70°C)	
Humidity	0-95%, non-condensing, corrosive	
Vibration and electrical safety	EN 61800-5-1 (2007) 5-15.8 Hz 1mm (peak) 15.8-150 Hz 1 G	
Emission	C2 level, EN 61800-3 (2004)	
Immunity	C2 level, EN 61800-3 (2004)	
CAN Interface	Isolation	2500 V rms isolation with a less than 10-ns propagation delay
	Protection	±8kV ESD IEC 61000-4-2 Contact Discharge ±80V Fault Protection greater than ±12V common Mode Range

3.2 CAN CABLE

The recommended cables for installation are 4-wire twisted and shielded cables with an impedance of 120 Ohm. The network topology is a 2-wire bus line that is terminated at both ends by resistors representing the characteristic impedance of the bus line. The typical CAN cable impedance is 120 Ohm, so you must use termination resistors of ~120 Ohm. For long networks, use a higher resistor value (150-300 Ohm).

Table 5. Bus parameter relation to cable length

Cable length	Max bit rate [kbit/s]
100 m	500
250 m	250
500 m	120

3.2.1 RECOMMENDED CABLE

For all DeviceNet installations the use of 4-wire cable is recommended.

Vacon recommends the following cable:

- UNITRONIC® BUS CAN FD P, colour-coded in accordance with DIN 47100.



Figure 3. Recommended cable

Table 6. Cable thickness, length and baud rate relation

Bit rate	Min cable thickness [mm ²]		
500 kbit/s	0.34		
250 kbit/s	0.34	0.6	
125 kbit/s	0.34	0.6	0.6
Cable length [m]	100	250	500

4. OPTE7 LAYOUT AND CONNECTIONS

4.1 LAYOUT AND CONNECTIONS

OPTE7 has two different hardware revisions with slightly different layouts. The layout is different in the LED arrangement and the termination resistor orientation.

The two hardware revisions are marked with different product codes, and this product code can be seen in the sticker on the top side of the option board (see the location in Figure 6).

The two hardware revisions are 70CVB01817 and 70CVB01555.

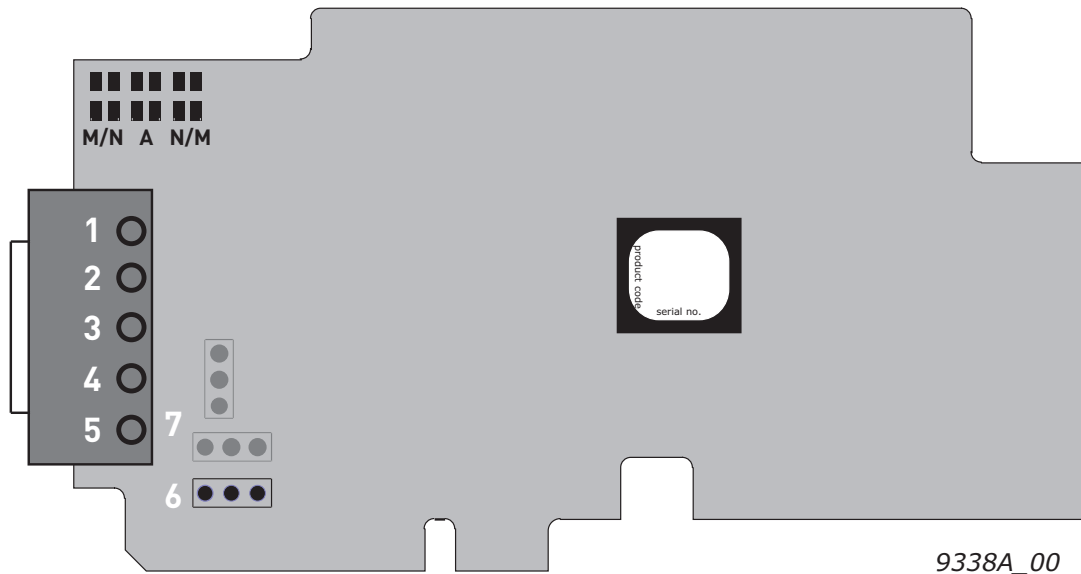

Figure 4. OPTE7 board layout

- 1 = V- (GND)
- 2 = CAN L
- 3 = SHIELD (shield connector)
- 4 = CAN H
- 5 = V+ (24V)
- 6 = Cable shield grounding option
- 7 = CAN bus termination jumper

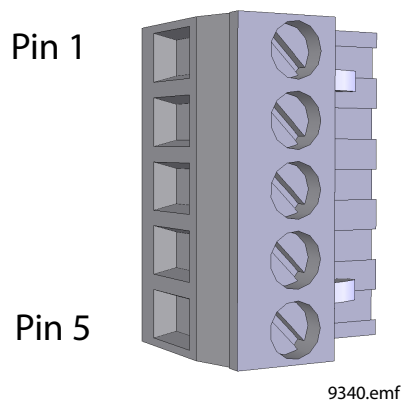

Figure 5. CAN connector

Table 7. CAN connector pinout

Pin	Description
1	V-, isolated digital ground
2	CAN LO
3	Shield connector
4	CAN HI
5	V+ (24V), communication power supply

4.2 LED INDICATIONS

The DeviceNet option board includes two LED status indicators next to the connector: network status (N), and module status (M).

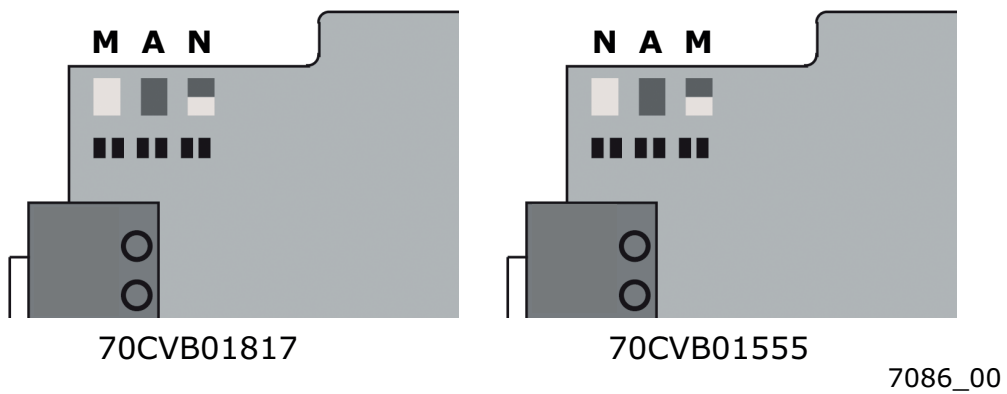

Figure 6. OPTE7 LED indicators

The network status provides information on the network connection status, and the module status provides information on the DeviceNet module.

Table 8. Module status led

LED status	Description
OFF	No power is supplied to the drive.
Green	OPTE7 is operating normally.
Flashing green	OPTE7 is in the Standby state, or the device needs commissioning due to missing, incomplete or incorrect configuration.
Flashing red	The OPTE7 has detected a Recoverable Fault.
Red	The OPTE7 has detected an Unrecoverable Fault.

Table 9. Network status led

LED status	Description
OFF	OPTE7 is not online. <ul style="list-style-type: none"> The device has not completed the Dup_MAC_ID test yet. If the Module Status LED is off, the device is not powered.
Flashing green	The OPTE7 has passed the Dup_MAC_ID test, is online, but is not allocated to a master.
Green	The OPTE7 is online and allocated to a master.
Flashing red	One or more I/O connections are in the Timed-Out state.
Red	The OPTE7 cannot communicate on the network (Duplicate MAC ID, or Bus-off).

4.3 JUMPERS

The termination resistor jumper location differs on used hardware version. The jumper locations can be seen from figure below.

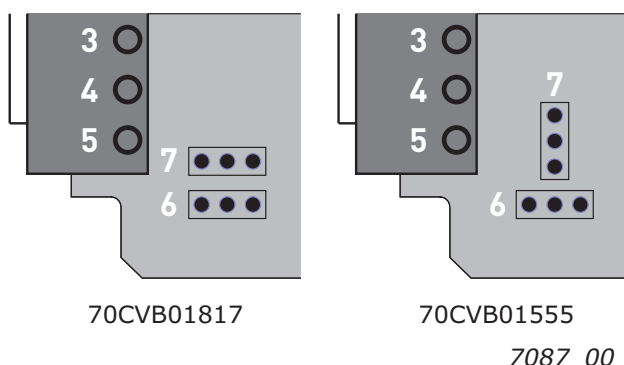

Figure 7. Jumper locations

The jumper settings for the CAN bus termination resistor are shown in the figure below.

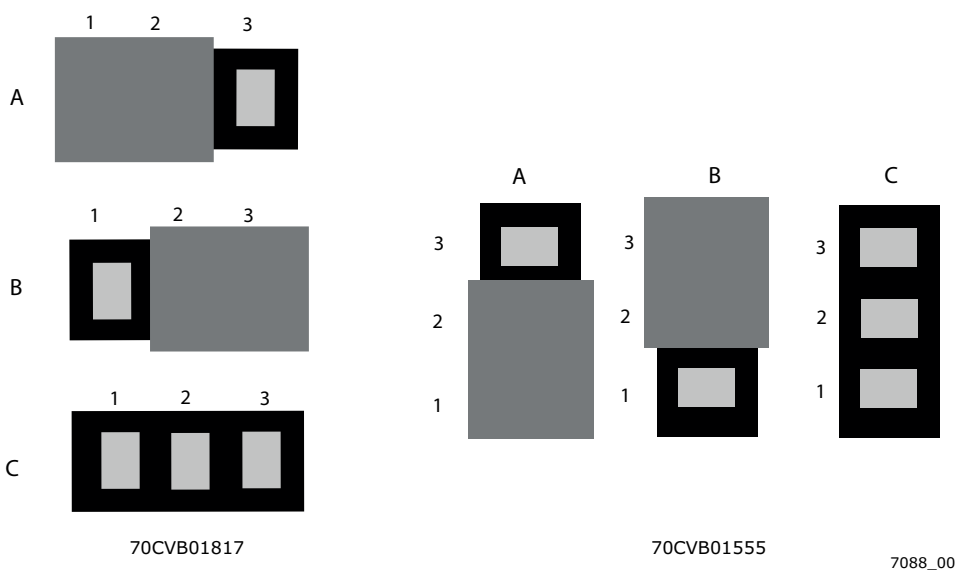

Figure 8. Termination resistor settings

A = Termination resistor 120 Ohm connected

B = Termination resistor is not connected to the CAN bus. (Factory default setting)

C = Termination resistor is not connected to the CAN bus

The jumper settings for the CAN cable shield grounding are shown in the following figure.

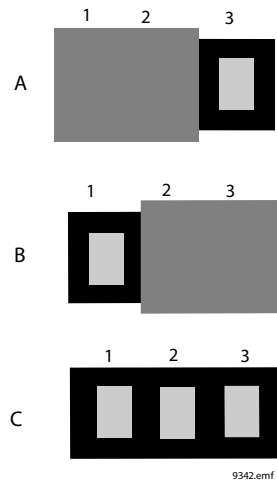

Figure 9. Cable shield grounding option

A = CAN connector pin 3 (shield) connected to the drive chassis with a high-impedance RC circuit. Recommended option when equipotential bonding is poor.

B = CAN connector pin 3 (shield) connected directly into the drive chassis. Recommended option when equipotential bonding is good. (Factory default setting).

C = CAN connector pin 3 is unconnected.

5. INSTALLATION

5.1 INSTALLATION IN VACON® 100

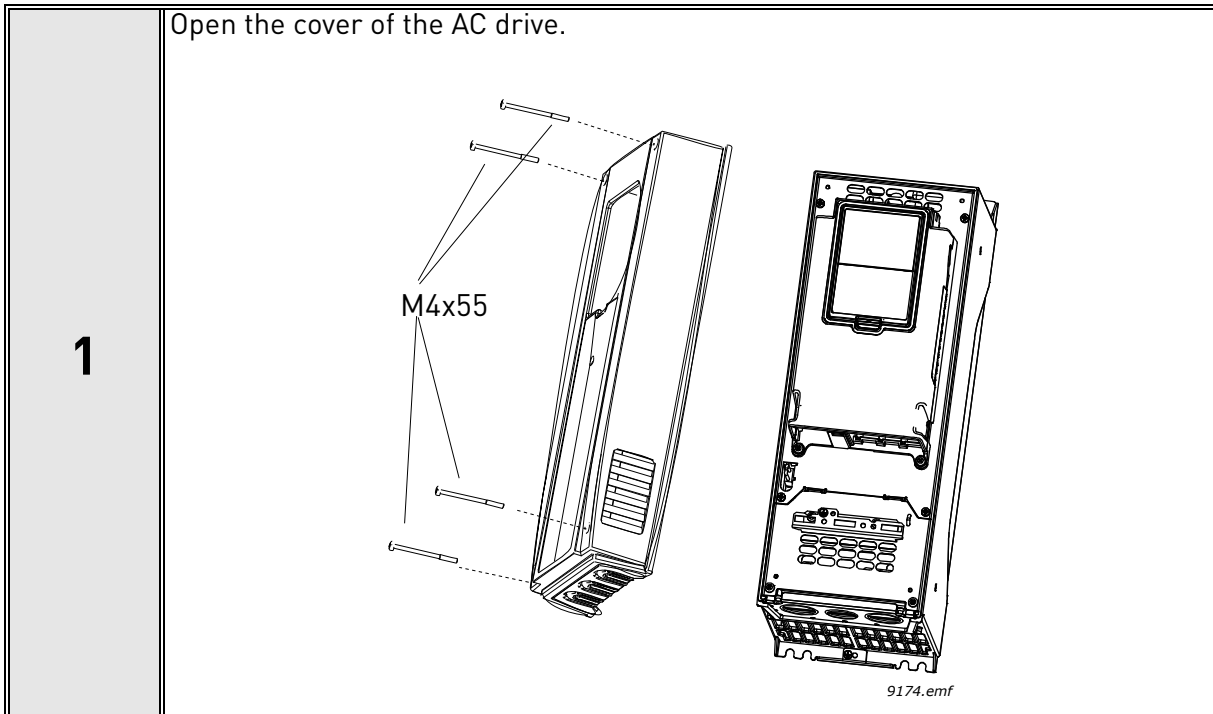

The relay outputs and other I/O terminals may have a dangerous control voltage present even when the AC drive is disconnected from mains.

2

Open the inner cover to reveal the option board slots (C,D,E).

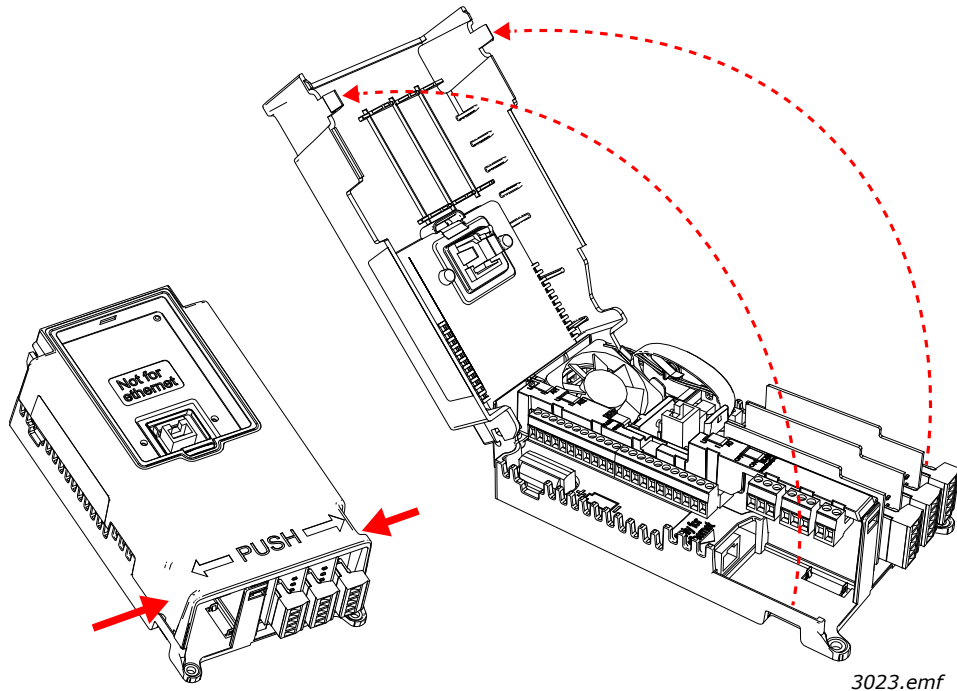

3023.emf

3

Install the fieldbus board into slot D or E.

NOTE! Incompatible boards cannot be installed on the drive. Compatible boards have a slot coding that enable the placing of the board.

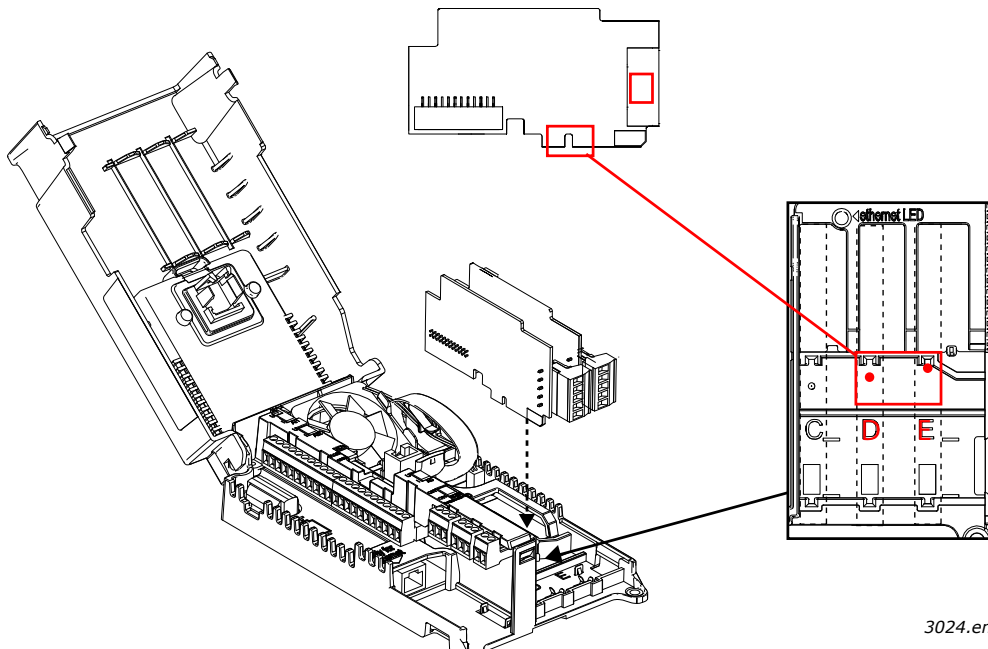

3024.emf

5.2 PREPARE FOR USE THROUGH FIELDBUS

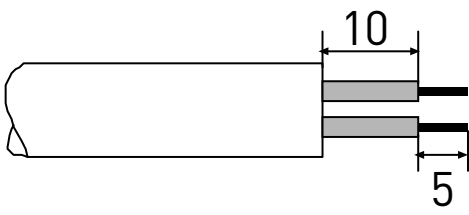
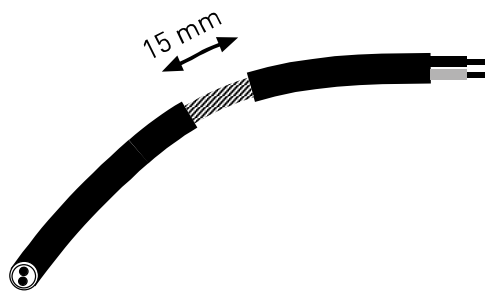
<p>4</p>	<p>Strip about 15 mm of the fieldbus cable and cut off the grey cable shield. Remember to do this for both bus cables (except for the last device). Leave no more than 10 mm of the cable outside the terminal block and strip the cables at about 5 mm to fit in the terminals.</p>  <p>Also strip the cable now at such a distance from the terminal that you can fix it to the frame with the grounding clamp. Strip the cable at a maximum length of 15 mm. Do not strip the aluminum cable shield!</p> 
<p>5</p>	<p>Then connect the cable to its appropriate terminals on the OPTE7 DeviceNet option board terminal block.</p>

<p>6</p>	<p>Using the cable clamp included in the delivery of the drive, ground the shield of the CAN cable to the frame of the AC drive.</p> <p>NOTE! This can be done in all drives if there is no difference in PE potential between the drives. However, if there is PE potential difference then the shield should be connected to PE only at one point in the system. The shields of the cables shall be joint but not connected to several PE points with different potential.</p> <div data-bbox="459 436 1228 952" style="text-align: center;"> <p style="text-align: right;">Cable clamp</p> </div>
<p>7</p>	<p>If the AC drive is the last device on the bus, the bus termination must be set with jumper X13.</p>
<p>8</p>	<p>Unless already done for the other control cables, cut free the opening on the AC drive cover for the fieldbus cable (protection class IP21).</p> <p>NOTE! Cut the opening on the same side you have installed the board in!</p> <div data-bbox="965 1075 1356 1635" style="text-align: center;"> </div>

9

Remount the AC drive cover and run the cable as shown in picture.

NOTE! When planning the cable runs, remember to keep the distance between the fieldbus cable and the motor cable at a **minimum of 30 cm**. It is recommended to route the option board cables away from the power cables as shown in the picture.

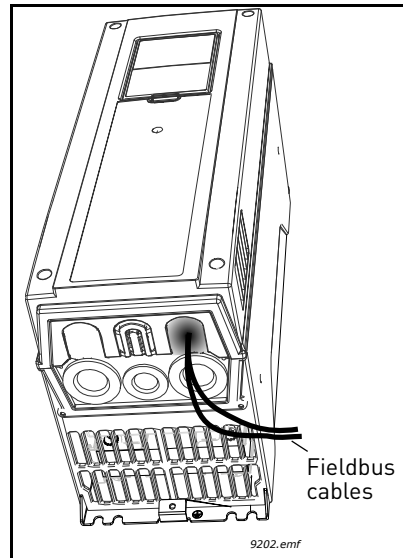

10

The bus termination must be set for the first and the last device of the fieldbus line. See also step 7 on page 19. We recommend that the first device on the bus and, thus, terminated was the master device.

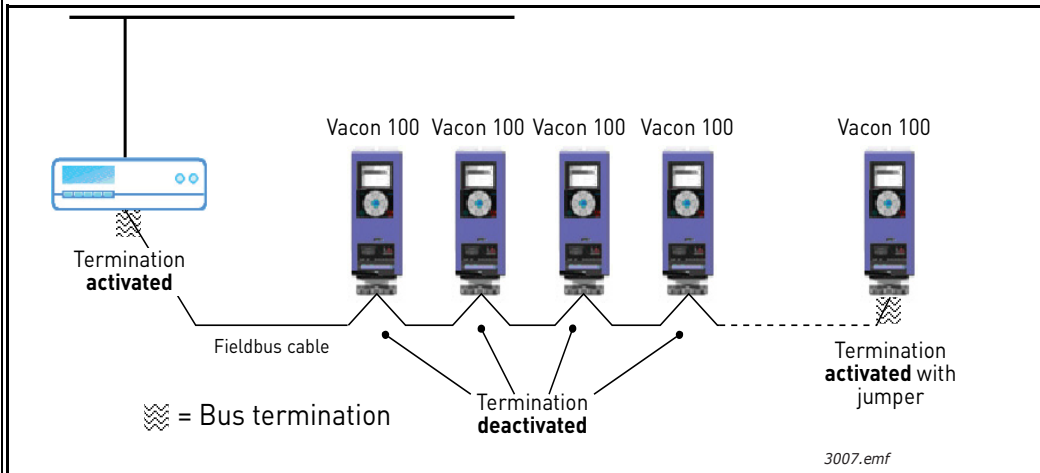

5.3 INSTALLATION IN VACON® 20

5.3.1 FRAMES MI1, MI2, MI3

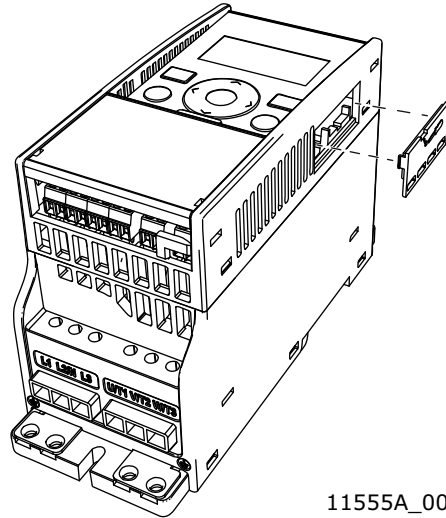
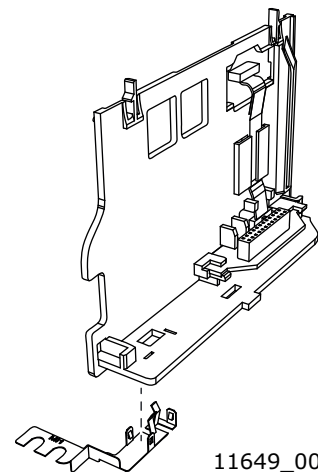
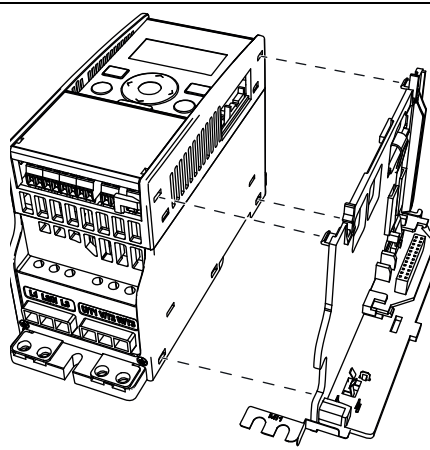
<p>1</p>	<p>Remove the cable connector lid from the AC drive.</p>  <p style="text-align: right;">11555A_00</p>
<p>2</p>	<p>Select a correct grounding plate and attach it to the option board mounting frame. The grounding plate is marked with the supported frame size.</p>  <p style="text-align: right;">11649_00</p>
<p>3</p>	<p>Attach an option board mounting frame to the drive.</p>  <p style="text-align: right;">11556A_01</p>

4

Connect the flat cable from the option board mounting frame to the drive.

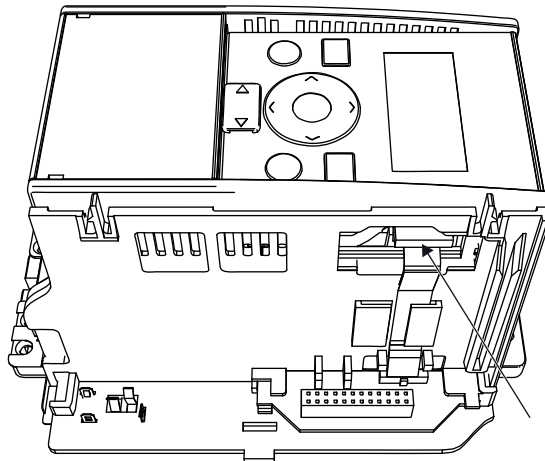

11557A_00

5

If a cable strain relief is required, attach the parts as shown in the figure.

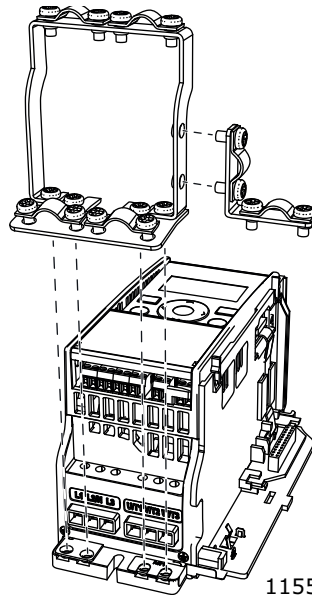

11558A_00

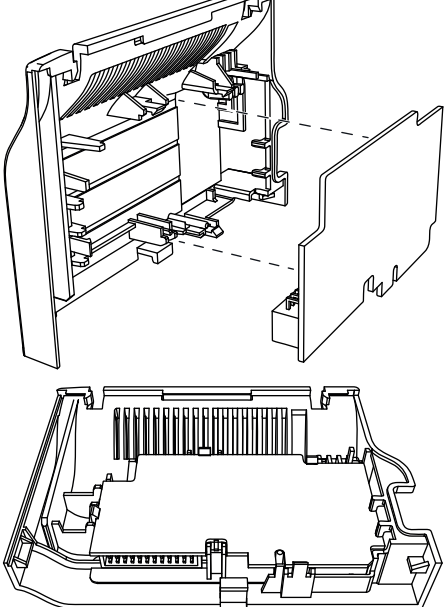
6	<p>Install the option board to the option board holder. Make sure that the option board is securely fastened.</p>	
----------	---	--

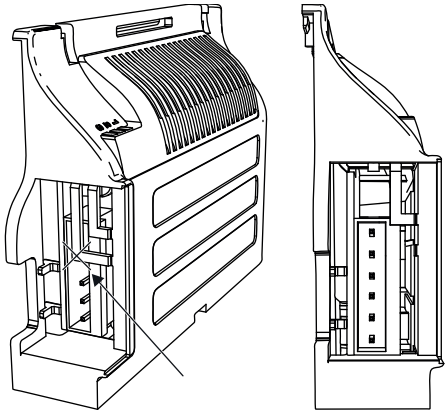
7	<p>Cut free a sufficiently wide opening for the option board connector.</p>	
----------	---	---

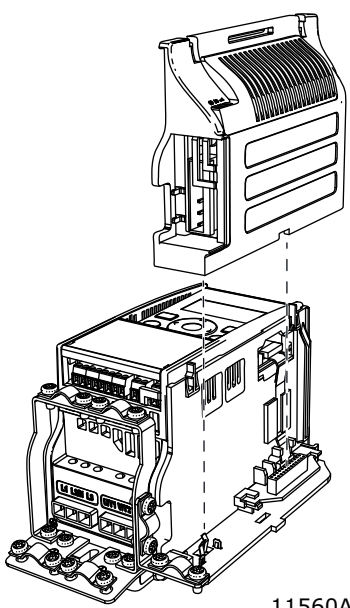
8	<p>Attach the option board cover to the drive. Attach the strain relief cable clamp with screws if needed.</p>	
----------	--	---

5.3.2 FRAMES MI4, MI5



Make sure power is disconnected before opening the cover of the drive.

1	<p>1a: For MI4: Open the cover.</p> <p style="text-align: right;">11561_00</p> <p>1b: For MI5: Open the cover and release the fan connector.</p> <p style="text-align: right;">11562_00</p>
2	<p>Attach the option board support.</p> <p style="text-align: right;">11563_00</p>

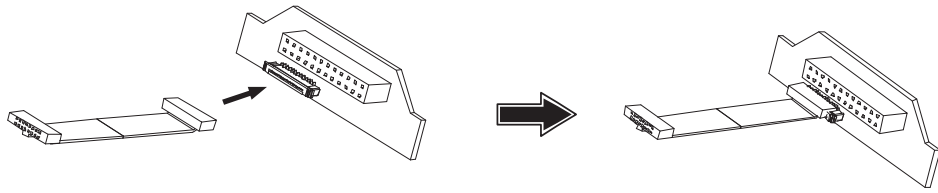
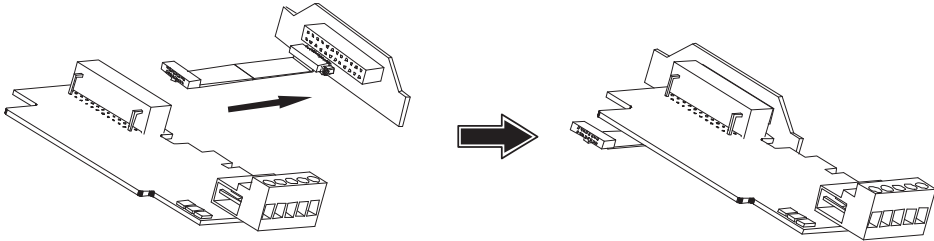
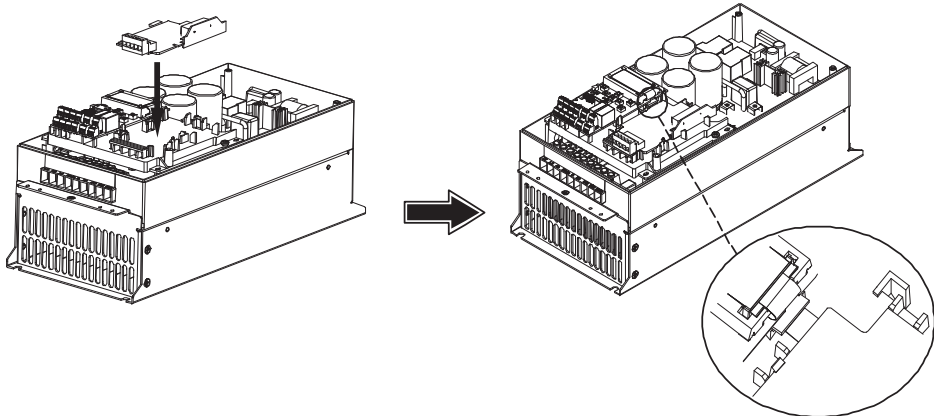
<p style="text-align: center; font-size: 24pt; font-weight: bold;">3</p>	<p>Connect the flex cable to option board connector PCB.</p>  <p style="text-align: right;">11564_00</p>
<p style="text-align: center; font-size: 24pt; font-weight: bold;">4</p>	<p>Connect the option board to connector PCB.</p>  <p style="text-align: right;">11565_00</p>
<p style="text-align: center; font-size: 24pt; font-weight: bold;">5</p>	<p>Attach the option board with connector PCB to the drive and connect the flex cable.</p>  <p style="text-align: right;">11566_00</p>

6

Attach a suitable grounding plate to the drive. The grounding plate is marked with supported frame size.

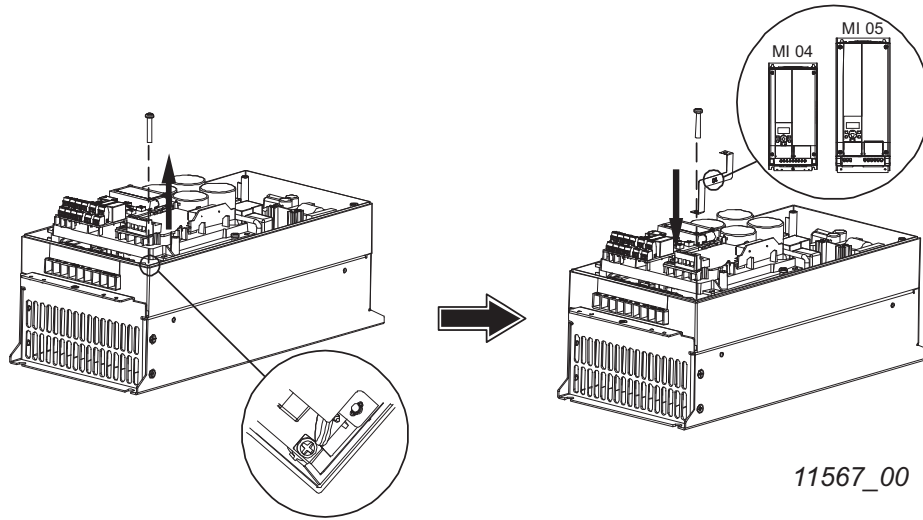

7

Assemble a clamp on top of the grounding plate on both sides of the option board.

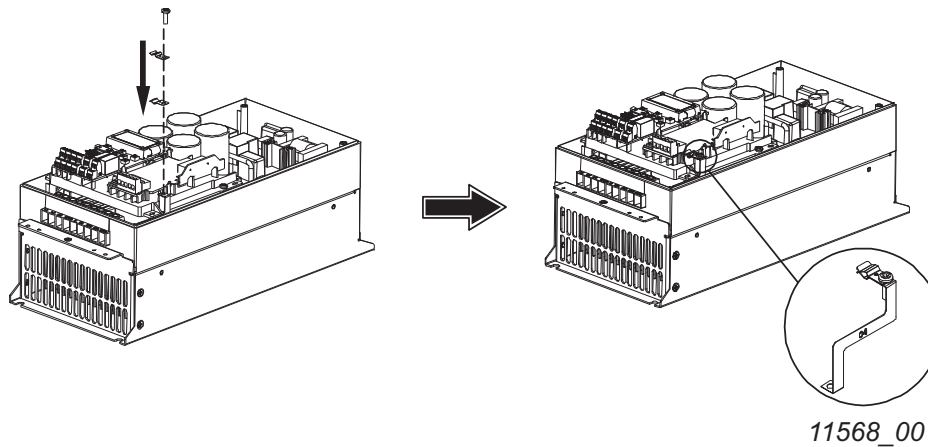

8

8a: For MI4: Close the cover.

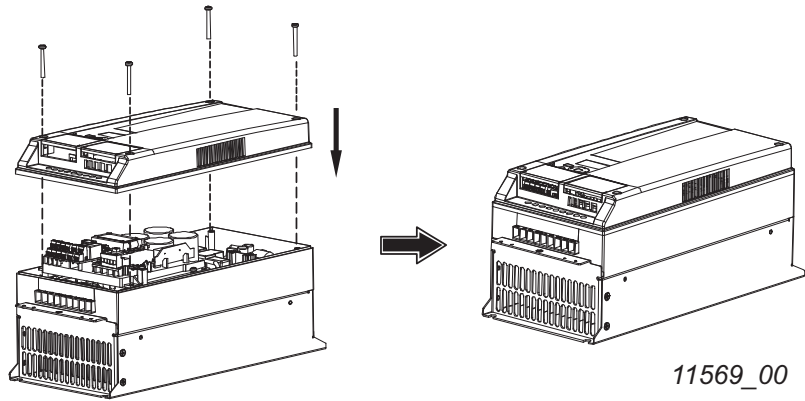

8b: For MI5: Remount the fan connector and close the cover.

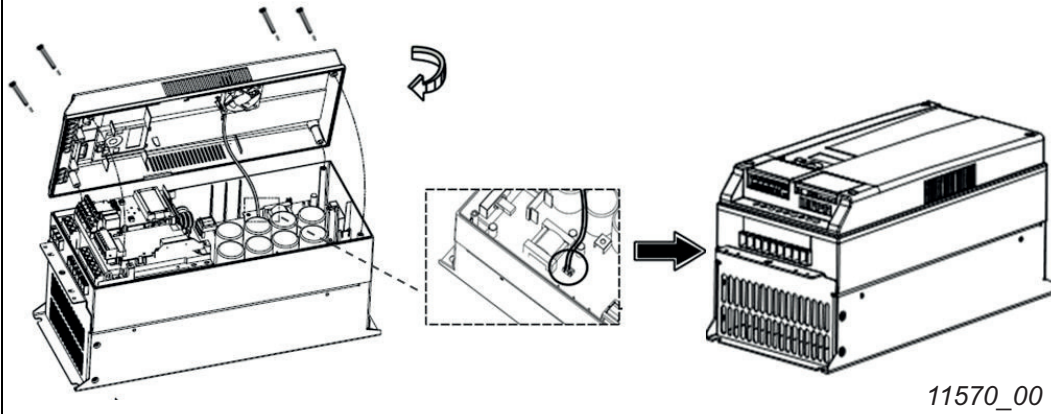

5.4 INSTALLATION IN VACON® 20 X AND 20 CP



Do not add or replace option boards or fieldbus boards on an AC drive with the power switched on. This may damage the boards.

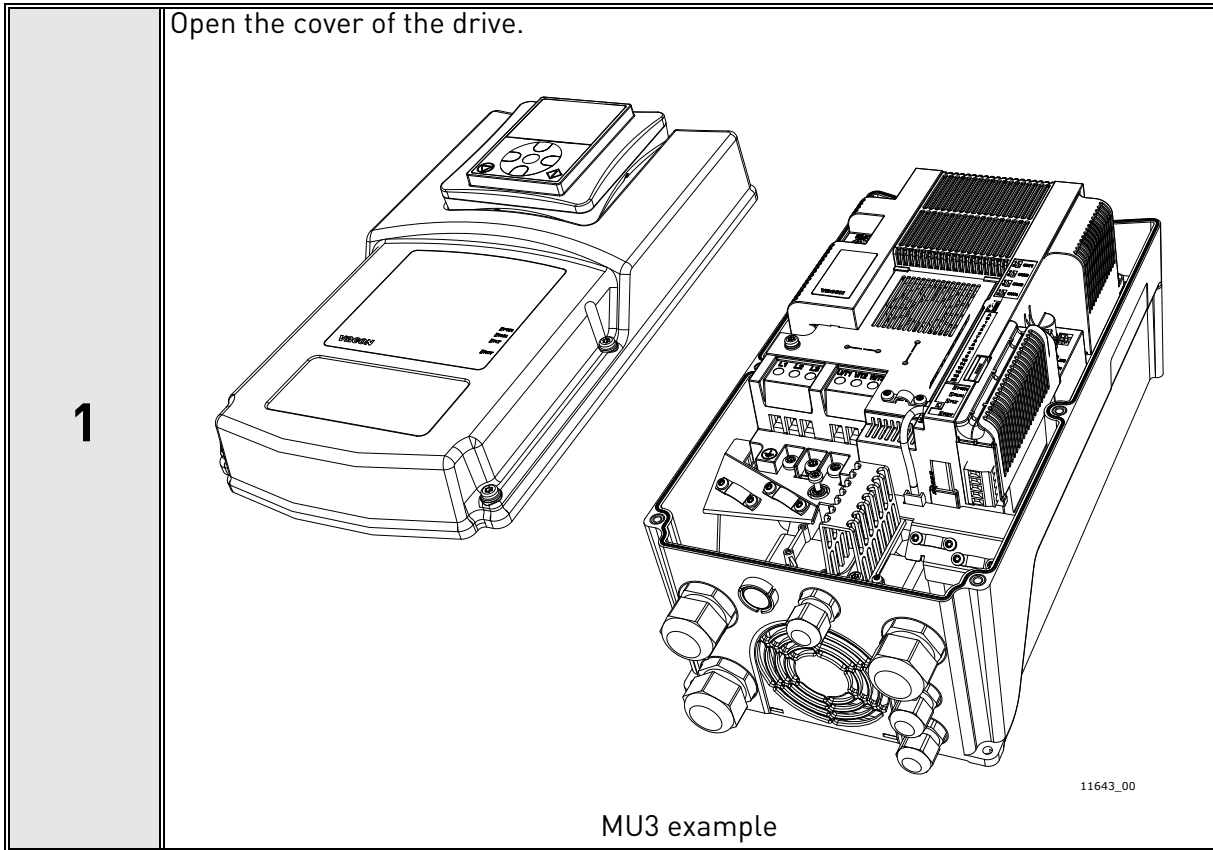

The relay outputs and other I/O-terminals may have a dangerous control voltage present even when the drive is disconnected from mains.

2

Remove the option slot cover.

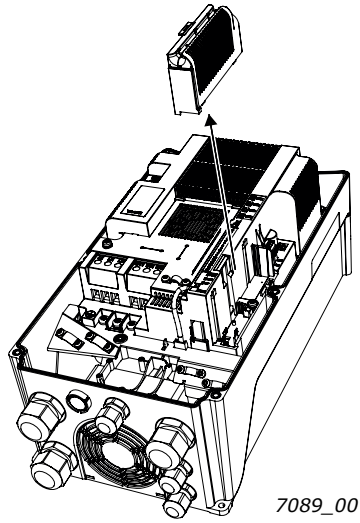

3

Install the option board into the slot as shown in the figure.

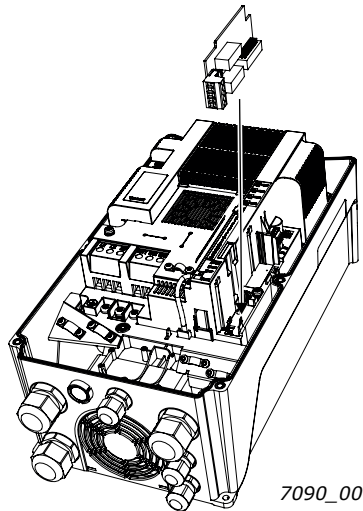

4

Mount the option slot cover. Remove the plastic opening for the option board terminals.

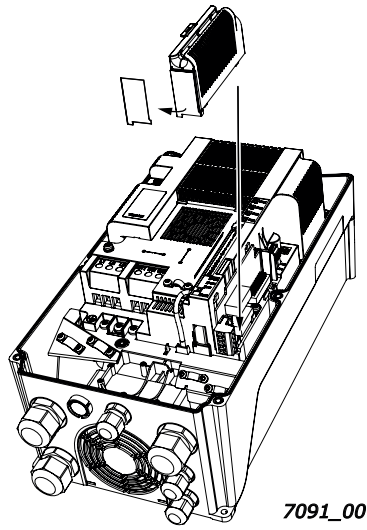

5.5 INSTALLATION IN VACON® 100 X (FRAMES MM4-MM6)

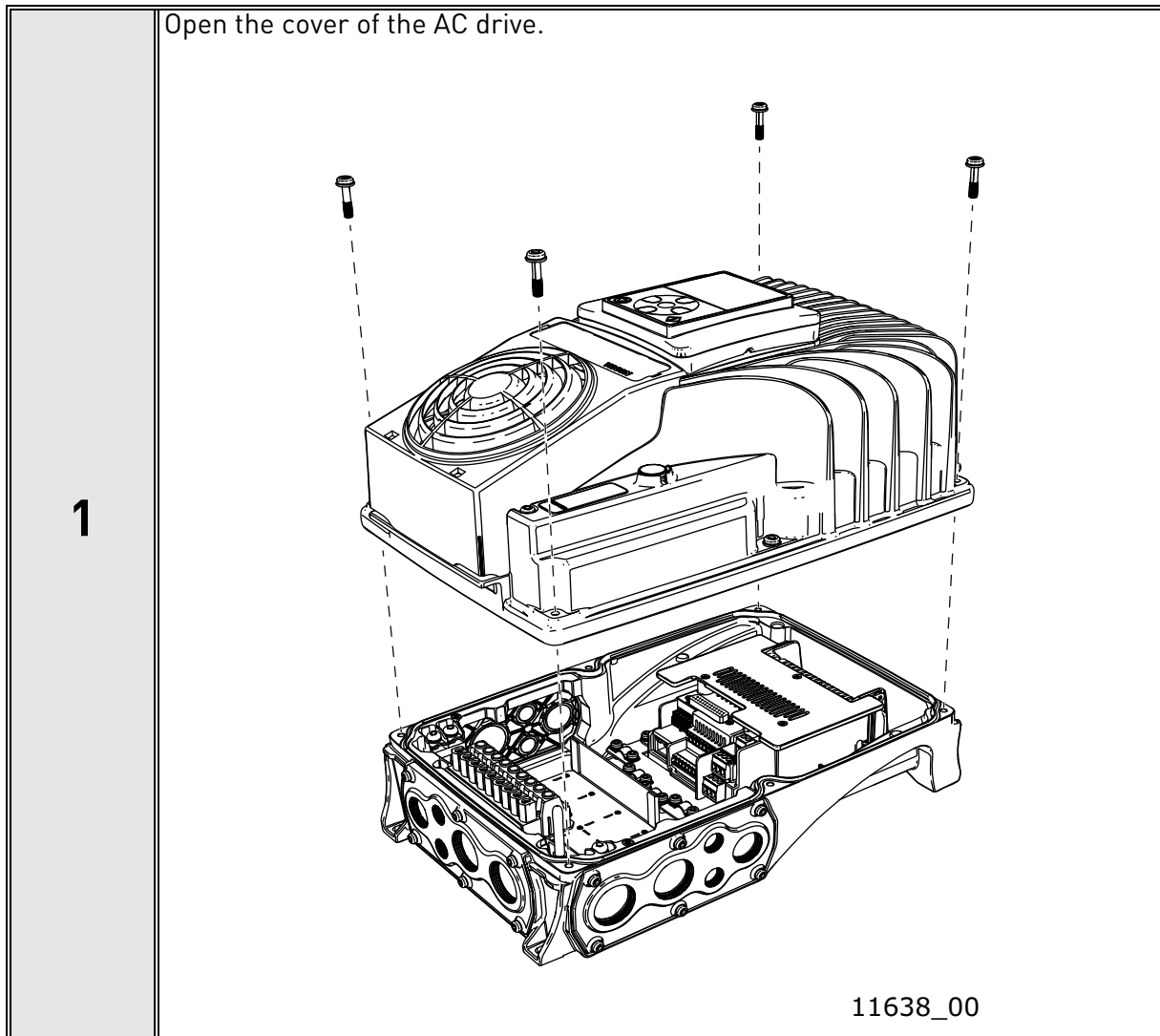

2

To get access to the option board slots, remove the screws and open the cover of the control unit.

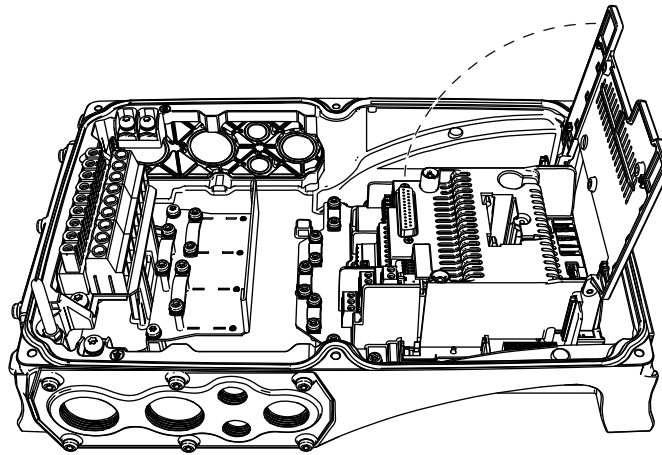
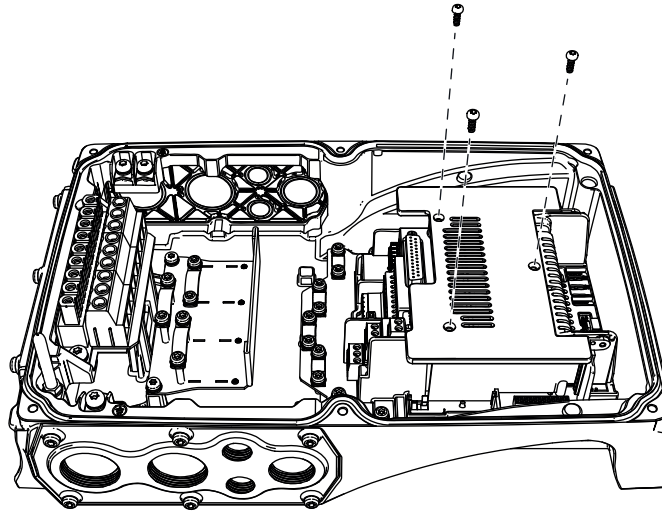

11639_00

3 Install the option board into the correct slot, D or E.

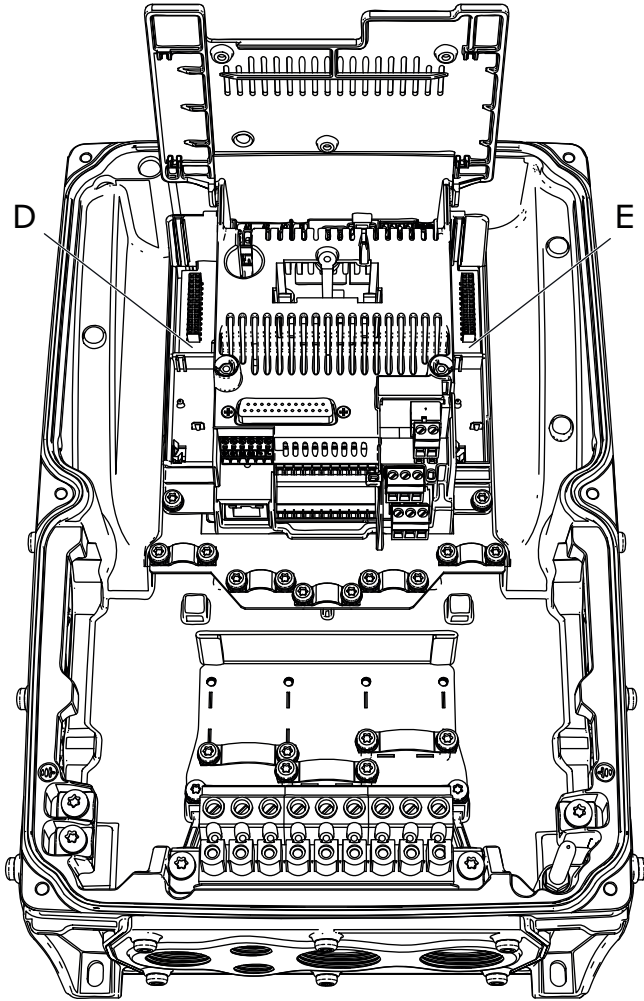

11640_00

4 Close the option board cover.

5 Remove the cable entry plate. If you installed the option board in the slot D, use the cable entry plate on the right side. If you installed the option board in the slot E, use the cable entry plate on the left side.

NOTE! The cable entry plate at the bottom of the drive is used only for mains and motor cables.

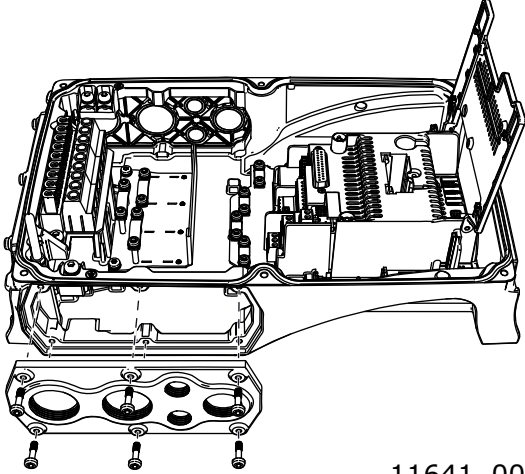

11641_00

6 Open the necessary holes in the cable entry plate. Do not open the other holes. See the Vacon® 100X Installation Manual for the dimensions of the holes.

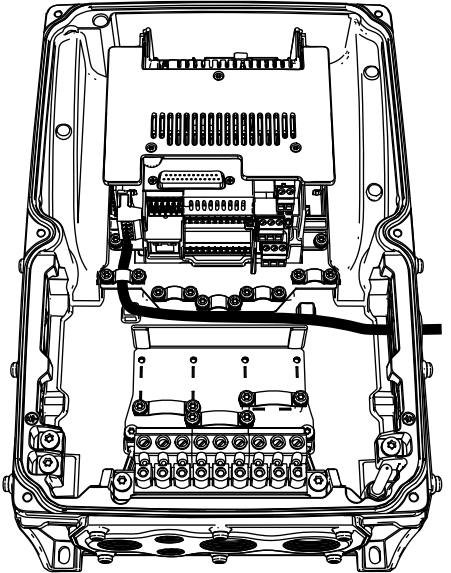
<p>7</p>	<p>Attach a cable gland on the hole in the cable entry plate. Pull the fieldbus cable through the hole.</p> <p>NOTE! The fieldbus cable must go through the correct cable entry plate to avoid going near the motor cable.</p>	 <p style="text-align: right;">11642_00</p>
<p>8</p>	<p>Put the cable entry plate back.</p>	
<p>9</p>	<p>Close the cover of the AC drive.</p>	

6. COMMISSIONING

6.1 PARAMETER VIEW

Table 10. Parameter view

Name	Default	Range	Description
MAC ID	63	0...63	Slave address. Valid device addresses are in the range of 0 to 63 decimal.
Baud rate	125 kbit/s	125 kbit/s 250 kbit/s 500 kbit/s	Communication speed
Output assembly	21	20 21 23 25 101 111	Output assembly used by the polled connection. Setting of this value via panel is not allowed when the I/O connection is established. If setting of this value fails, the value is not updated.
Input assembly	71	70 71 73 75 107 117	Input assembly used by the polled connection. Setting of this value via panel is not allowed when the I/O connection is established! If setting of this value fails, the value is not updated.

6.2 MONITOR VIEW

Table 11. Monitor view

Name	Range	Description
DeviceNet Status	Y.X	Y = Message counter X = DeviceNet status

Table 12. DeviceNet status

DeviceNet Status	Description
0	Non-existent
1	Configuring
3	Established
4	Timeout

6.3 SOFTWARE INFO VIEW

Table 13. Software info view

Number	Name	Range	Description
1	Version number		Version number of the software in the option board
2	Board status		Shows the status of the option board

6.4 FIELDBUS PARAMETRISATION

The following chapter describes briefly, how to parametrise the AC drive in order for the motor to be controllable via fieldbus. These instructions are written for some basic applications. For more information, please consult the application-specific manual.

In order for the AC drive to accept commands from the fieldbus network, the control place of the AC drive has to be set to fieldbus. The default value of the parameter "Control Place" is usually I/O. Note that if the control unit firmware is updated, the default settings are restored. In addition, some applications may have the remote speed reference selection set by default to other than fieldbus. In these cases, the speed reference selection must be set to fieldbus, in order for the speed reference to be controlled via fieldbus.

In DeviceNet, the bits NetCtrl, NetRef and NetProc must be set in order for the option board to send commands / reference setpoint values to the AC drive. The bits Ctrl From Net and Ref From Net can be read to determine the actual control / reference place. Note that these bits are valid only if NetCtrl / NetRef bits are also set.

NOTE! The motor control mode should be selected to support the used process and profile.

6.4.1 FIELDBUS CONTROL AND BASIC REFERENCE SELECTION

The following tables list some of the parameters related to fieldbus control in case of three standard applications, the Vacon® 100, Vacon® 20 and Vacon® 20X, for use via fieldbus. See the application-specific manuals for more detailed information.

Table 14. Parametrisation for Vacon® 100 (standard application)

Parameter name	ID	Value	Default	Panel Tree	Class, Instance, Attribute
Control mode	600	0 = Frequency 1 = Speed 2 = Torque	0	P 3.1.2.1	0xA0, 0x03, 0x58
Remote control place	172	1 = Fieldbus CTRL	0	P 3.2.1	0xA0, 0x01, 0xAC
Local / remote	211	0 = Remote	0	P 3.2.2	0xA0, 0x01, 0xD3
Fieldbus ref. sel.	122	3 = Fieldbus	3	P 3.3.1.10	0xA0, 0x01, 0x7A

Table 15. Parametrisation for Vacon® 20 (standard application)

Parameter name	ID	Value	Default	Panel Tree	Class, Instance, Attribute
Motor control mode	600	0 = Frequency 1 = Speed	0	P 1.8	0xA0, 0x03, 0x58
Rem. control place 1 sel.	172	1 = Fieldbus CTRL	0	P 2.1	0xA0, 0x01, 0xAC
Local / remote	211	0 = Remote	0	P 2.5	0xA0, 0x01, 0xD3
Rem. control place 1 freq. ref. sel.	117	3 = Fieldbus	7	P 3.3	0xA0, 0x01, 0x75

Table 16. Parametrisation for Vacon® 20X (standard application)

Parameter name	ID	Value	Default	Panel Tree	Class, Instance, Attribute
Motor control mode	600	0 = Frequency 1 = Speed	0	P 8.1	0xA0, 0x03, 0x58
Control place selection	125	2 = Fieldbus	0	P 1.11	0xA0, 0x01 0x7D
Local / remote	211	0 = Remote	0	P 3.2.2	0xA0, 0x01, 0xD3
Frequency ref. sel.	1819	5 = Fieldbus	5-7	P 1.12	0xA0, 0x08, 0x1B

6.4.2 TORQUE CONTROL PARAMETRISATION

Some extra parametrisation has to be made in order to control the frequency control with torque control. The following instructions are for the Vacon 100 application, see the application-specific manual for more detailed information.

- Motor control mode (ID 600) should be configured to “Torque control (Open Loop)” (2).

To configure the drive to use correct torque reference, parameter “Torque Reference Selection” should be selected to ProcessDataIn1 (9). This can be done with:

- PC-tool or panel (P 3.3.2.1) / ID 641
- Vendor Parameter Object TorqueRefSel (Class 0xA0, Instance 0x03, Attribute 0x81)

6.4.3 PROCESS DATA MAPPING AND DEFAULT SETTINGS

In DeviceNet, output instances 107 and 117 (Chapter 7.1.2.5 and 7.1.2.6), can be used to send process data to network. This data is selectable in the application and the default settings vary between drives. Refer to the application manual for details. The following tables show the default values for Vacon 100, Vacon 20X and Vacon 20 applications.

Table 17. Process data output mapping defaults for Vacon® 100 and Vacon® 20X (standard applications)

PD Out	AC Drive	Mapped Application Data	Unit	Scale
1	Vacon 100	Output Frequency	Hz	0.01 Hz
	Vacon 20X	Output Current	A	Varies
2	Vacon 100 & Vacon 20X	Motor Speed	rpm	1 rpm
3	Vacon 100 & Vacon 20X	Motor Current	A	Varies
4	Vacon 100 & Vacon 20X	Motor Torque	%	0.1%
5	Vacon 100 & Vacon 20X	Motor Power	%	0.1%
6	Vacon 100 & Vacon 20X	Motor Voltage	V	0.1 V
7	Vacon 100 & Vacon 20X	DC Link Voltage	V	1 V
8	Vacon 100 & Vacon 20X	Last Active Fault Code	-	-

Table 18. Process data output mapping defaults for Vacon® 20 (standard application)

PD Out	AC Drive	Mapped Application Data	Unit	Scale
1	Vacon 20	Frequency Reference	Hz	0.01 Hz
2	Vacon 20	Output Reference	Hz	0.01 Hz
3	Vacon 20	Motor Speed	rpm	1 rpm
4	Vacon 20	Motor Voltage	V	0.1 V
5	Vacon 20	Motor Torque	%	0.1%
6	Vacon 20	Motor Current	A	Varies
7	Vacon 20	Motor Power	%	0.1%
8	Vacon 20	DC Link Voltage	V	1 V

7. DECIVENET INTERFACE

Vacon supports two types of DeviceNet messaging. They are I/O Messaging and Explicit Messaging.

7.1 I/O MESSAGING

I/O polling messages are for time-critical, control-oriented data. The messages are transferred between the devices all the time and they are used for continuous control of the AC drive. They provide a dedicated, special-purpose communication path between a producing application (master) and one or more consuming applications (slaves). They are exchanged across single or multi-cast connections, typically using high priority identifiers. I/O polling messages contain no protocol in the 8-byte data field. The meaning of the message is implied by the connection ID (CAN identifier). Before messages are sent using these IDs, both the device sending and receiving them must be configured. The configuration contains the source and destination object attribute addresses for the master and the slave.

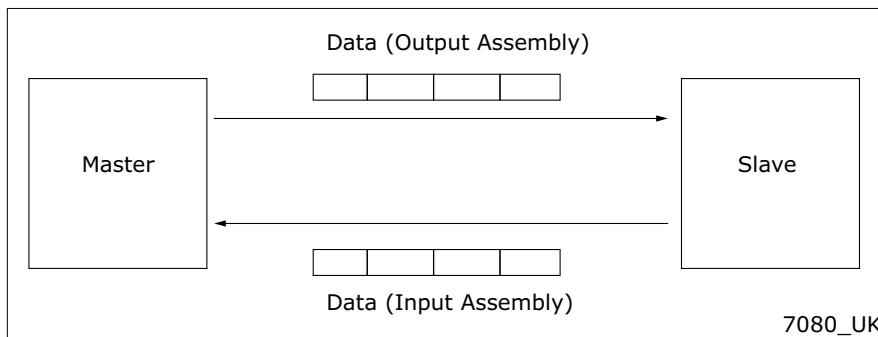

Figure 10. DeviceNet I/O messaging

The contents of the data message are chosen by input and output assemblies. These assemblies can be selected via panel or by setting Produced Connection Path (14) and Consumed Connection Path (16) attributes in DeviceNet connection object. Note that setting of instances is not allowed via panel, if I/O connection is open. See Chapter 10.2 for more details. Chapter 7.1.2 describes all supported input and output assemblies.

7.1.1 CONNECTION BEHAVIOUR

The following figure provides a general overview of the behaviour associated with an I/O connection object (instance type attribute = I/O).

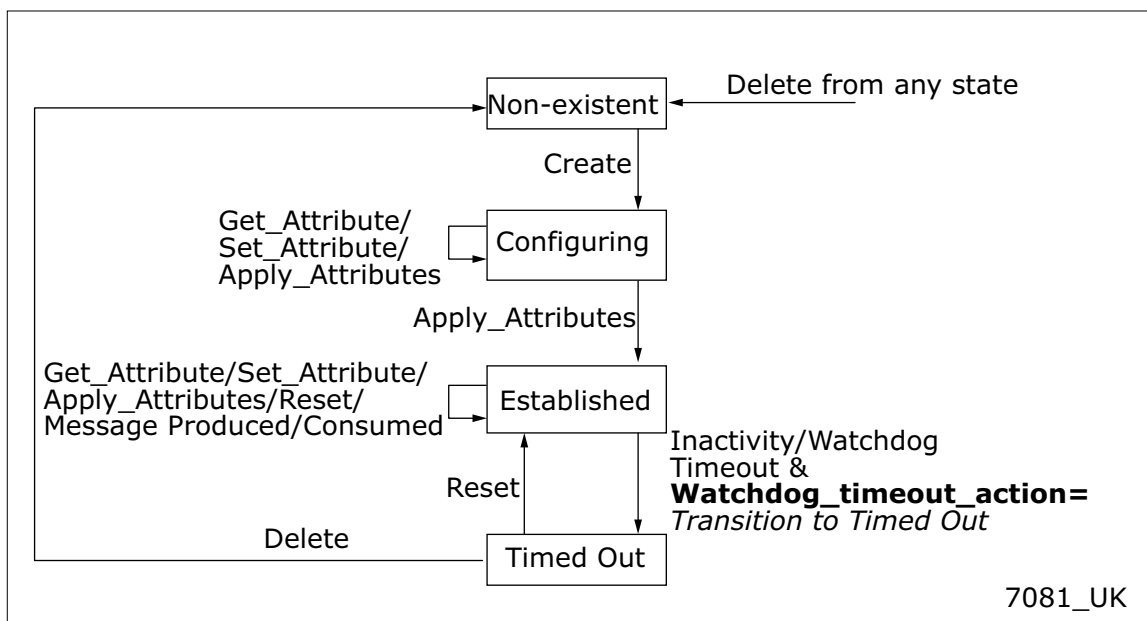

Figure 11. I/O Connection Object State Transition Diagram

By default, Expected Packet Rate (EPR) of I/O connection is set to zero, meaning that no transition to Timed Out state will occur. If EPR Timeout is set to other than zero, timeout will occur after four times Expected Packet Rate (4 * EPR). For example value 1000 (ms) will result in timeout after four seconds.

7.1.2 INPUT AND OUTPUT ASSEMBLIES

The following chapters describe the used input/output assemblies.

Table 19. Supported Input / Output Assemblies

Name	Profile	Number	Type
Basic Speed Control	CIP	20	Output
		70	Input
Extended Speed Control (default)	CIP	21	Output
		71	Input
Extended Speed and Torque Control	CIP	23	Output
		73	Input
Process Control	CIP	25	Output
		75	Input
Dynamic Process Control	Vacon	101	Output
		107	Input
Bypass Control Output	Vacon	111	Output
		117	Input

7.1.2.1 20/70 Basic Speed Control

Basic speed control is the most basic control type, where the run direction is limited to only forward, and only Run and Fault reset commands are supported. Speed reference is given in revolutions per minute. The run/stop commands work as described in Table 39, with Run Rev always interpreted as zero. In this mode, the control supervisor attributes NetCtrl and NetRef bits are always set to one.

Table 20. Basic Speed Control Instance descriptions

Instance	Byte	Bit7	Bit6	Bit5	Bit4	Bit3	Bit2	Bit1	Bit0
Basic Speed Control Output									
20	0						Fault Reset		Run Fwd
	1								
	2	Speed Reference (Low Byte)							
	3	Speed Reference (High Byte)							
Basic Speed Control Input									
70	0						Running1		Faulted
	1								
	2	Speed Actual (Low Byte)							
	3	Speed Actual (High Byte)							

Table 21. Basic Speed Control Attribute descriptions

Attribute	Unit	Range	Note
Speed Reference	rpm	0-32767	
Speed Actual	rpm	0-32767	

7.1.2.2 21/71 Extended Speed Control [default]

Extended speed control provides more functionality over the basic speed control. NetRef and NetCtrl bits must be set to one, in order for the commands and reference values to be sent to the AC drive. When these bits are set, the actual control/reference place can be read from "Ctrl From Net" and "Ref From Net" bits. Run Forward and Run Reverse bits are used to control the direction of the motor. See Table 39 for complete description of the run commands.

Table 22. Basic Speed Control Instance descriptions

Instance	Byte	Bit7	Bit6	Bit5	Bit4	Bit3	Bit2	Bit1	Bit0
Extended Speed Control Output									
21	0		NetRef	NetCtrl			Fault Reset	Run Rev	Run Fwd
	1								
	2	Speed Reference (Low Byte)							
	3	Speed Reference (High Byte)							
Extended Speed Control Input									
71	0	At Reference	Ref from Net	Ctrl from Net	Ready	Running2 (Rev)	Running1	Warning	Faulted
	1	Drive State							
	2	Speed Actual (Low Byte)							
	3	Speed Actual (High Byte)							

Table 23. Extended Speed Control Attribute descriptions

Attribute	Unit	Range	Note
Speed Reference	rpm	0-32767	
Speed Actual	rpm	0-32767	
Drive State	-	0-7	See Chapter 7.1.3

7.1.2.3 23/73 Extended Speed and Torque Control

Extended speed and torque assemblies can be used when torque reference is needed.

Torque Reference is converted from $\tau^{(Nm)}/2^n$, where n is the torque scale value (AC/DC Drive object, instance 2, attribute 24), to a %-value for the AC drive. This value is sent in ProcessDataIn1 for the control unit when NetRef bit is set. Therefore, ProcessDataIn1 should be selected as torque reference selection. See the application manual or Chapter 6.4.2 for more details.

Table 24. Extended Speed and Torque Control Instance descriptions

Instance	Byte	Bit7	Bit6	Bit5	Bit4	Bit3	Bit2	Bit1	Bit0
Extended Speed and Torque Control Output									
23	0		NetRef	NetCtrl			Fault Reset	Run Rev	Run Fwd
	1								
	2	Speed Reference (Low Byte)							
	3	Speed Reference (High Byte)							
	4	Torque Reference (Low Byte)							
	5	Torque Reference (High Byte)							

Table 24. Extended Speed and Torque Control Instance descriptions

Instance	Byte	Bit7	Bit6	Bit5	Bit4	Bit3	Bit2	Bit1	Bit0
Extended Speed and Torque Control Input									
73	0	At Reference	Ref from Net	Ctrl from Net	Ready	Running2 (Rev)	Running1	Warning	Faulted
	1	Drive State							
	2	Speed Actual (Low Byte)							
	3	Speed Actual (High Byte)							
	4	Torque Actual (Low Byte)							
	5	Torque Actual (High Byte)							

Table 25. Extended Speed and Torque Control Attribute descriptions

Attribute	Unit	Range	Note
Speed Reference	rpm	0-32767	
Speed Actual	rpm	0-32767	
Torque Reference	Nm/2 ^{Torque Scale}	-32768...32767	
Torque Actual	Nm/2 ^{Torque Scale}	-32768...32767	
Drive State	-	0-7	See Chapter 7.1.3

7.1.2.4 25/75 Extended Process Control

Extended process control assemblies can be used to send process reference value directly to the application. The Process Reference value destination can be selected with Drive Mode byte according to Table 28. This should be configured in application as the receiving input. Process Actual value is always mapped to ProcessDataOut1. Note that process reference value is sent to drive only when NetProc bit is set.

Table 26. Extended Process Control Instance descriptions

Instance	Byte	Bit7	Bit6	Bit5	Bit4	Bit3	Bit2	Bit1	Bit0
Extended Process Control Output									
25	0	Net-Proc	NetRef	NetCtrl			Fault Reset	Run Rev	Run Fwd
	1	Drive Mode							
	2	Speed Reference (Low Byte)							
	3	Speed Reference (High Byte)							
	4	Process Reference (Low Byte)							
	5	Process Reference (High Byte)							

Table 26. Extended Process Control Instance descriptions

Instance	Byte	Bit7	Bit6	Bit5	Bit4	Bit3	Bit2	Bit1	Bit0
Extended Process Control Input									
75	0	At Reference	Ref from Net	Ctrl from Net	Ready	Running2 (Rev)	Running1	Warning	Faulted
	1	Drive State							
	2	Speed Actual (Low Byte)							
	3	Speed Actual (High Byte)							
	4	Process Actual (Low Byte)							
	5	Process Actual (High Byte)							

Table 27. Extended Process Control Attribute descriptions

Attribute	Unit	Range	Note
Speed Reference	rpm	0-32767	
Speed Actual	rpm	0-32767	
Process Reference	-	-	See Table 28
Process Actual	-	-	ProcessDataOut1
Drive Mode	-	-	See Table 28
Drive State	-	0-7	See Chapter 7.1.3

Table 28. Drive Mode selection in Process Control

Drive Mode	Process Reference Mapping
0	ProcessDataIn1
4	ProcessDataIn2
Other	Not valid

7.1.2.5 101/107 Vendor Dynamic Process Control

These assemblies can be used to send/receive process data directly to and from the application. The FB Speed Reference and the FB Speed Actual values are given as percentage of the minimum and maximum frequency. The control and status words are still given as CIP standard specific values.

Table 29. Vendor Dynamic Process Control Instance descriptions

Instance	Byte	Bit7	Bit6	Bit5	Bit4	Bit3	Bit2	Bit1	Bit0	
Dynamic Process Control Output										
101	0		NetRef	NetCtrl			Fault Reset	Run Rev	Run Fwd	
	1	Process Data 1 Selector (bits 4-7)				Process Data 2 Selector (bits 0-3)				
	2	FB Speed Reference (Low Byte)								
	3	FB Speed Reference (High Byte)								
	4	ProcessDataIn1 (Low Byte)								
	5	ProcessDataIn1 (High Byte)								
	6	ProcessDataIn2 (Low Byte)								
	7	ProcessDataIn2 (High Byte)								
Dynamic Process Control Input										
107	0	At Reference	Ref from Net	Ctrl from Net	Ready	Running2 (Rev)	Running1	Warning	Faulted	
	1	Drive State								
	2	FB Speed Actual (Low Byte)								
	3	FB Speed Actual (High Byte)								
	4	ProcessDataOut1 (Low Byte)								
	5	ProcessDataOut1 (High Byte)								
	6	ProcessDataOut2 (Low Byte)								
	7	ProcessDataOut2 (High Byte)								

Table 30. Vendor Dynamic Process Control Attribute descriptions

Attribute	Unit	Range	Note
FB Speed Reference	%	0-10000 (100.00%)	
FB Speed Actual	%	0-10000 (100.00%)	
ProcessDataIn1	-	-	
ProcessDataIn2	-	-	
ProcessDataOut1	-	-	See Table 31
ProcessDataOut2	-	-	See Table 31
Process Data Selector	-	-	See Table 31
Drive State	-	0-7	See Chapter 7.1.3

Process data selector bits can be used to select what content is mapped to ProcessDataOut 1 & 2 (bytes 4-7). The following table describes what values in these fields correspond to which process data items.

Table 31. Process Data Selector 1 & 2 description

Value	Bytes 4-5 of instance 107	Bytes 6-7 of instance 107
0 *	Speed Actual [%]	Speed Actual [%]
1	ProcessDataOut1	ProcessDataOut1
2	ProcessDataOut2	ProcessDataOut2
3	ProcessDataOut3	ProcessDataOut3
4	ProcessDataOut4	ProcessDataOut4
5	ProcessDataOut5	ProcessDataOut5
6	ProcessDataOut6	ProcessDataOut6
7	ProcessDataOut7	ProcessDataOut7
8	ProcessDataOut8	ProcessDataOut8
Other	ProcessDataOut1	ProcessDataOut2

* If both Process Data selectors are 0, bytes 4-5 are ProcessDataOut1 and bytes 6-7 are ProcessDataOut2.

7.1.2.6 111/117 Vendor Bypass Control

These assemblies can be used to bypass the CIP standard assemblies, and control the AC drive application directly. The FB Speed Reference and the FB Speed Actual values are given as percentage of the minimum and maximum frequency. The control and status words are application-specific values. Table 34 and Table 35 describe the control word, and Table 36 and Table 37 describe the fieldbus status words that are commonly used. Note that not all applications support all bits, and so application-specific manuals should be consulted.

Table 32. Vendor Bypass Control Instance descriptions

Instance	Byte	Bit7	Bit6	Bit5	Bit4	Bit3	Bit2	Bit1	Bit0
Bypass Control Output									
111	0-1	Control Word							
	2-3	FB Speed Reference							
	4-5	ProcessDataIn1							
	6-7	ProcessDataIn2							
	8-9	ProcessDataIn3							
	10-11	ProcessDataIn4							
	12-13	ProcessDataIn5							
	14-15	ProcessDataIn6							
	16-17	ProcessDataIn7							
18-19	ProcessDataIn8								

Table 32. Vendor Bypass Control Instance descriptions

Instance	Byte	Bit7	Bit6	Bit5	Bit4	Bit3	Bit2	Bit1	Bit0
Bypass Control Input									
117	0-1	Status Word							
	2-3	FB Speed Actual [%]							
	4-5	FB Speed Actual [rpm]							
	6-7	Speed Actual With Slip							
	8-17	Reserved							
	18-19	ProcessDataOut1							
	20-21	ProcessDataOut2							
	22-23	ProcessDataOut3							
	24-25	ProcessDataOut4							
	26-27	ProcessDataOut5							
	28-29	ProcessDataOut6							
	30-31	ProcessDataOut7							
	32-33	ProcessDataOut8							

Table 33. Vendor Bypass Control Attribute descriptions

Attribute	Unit	Range	Note
FB Speed Reference	%	0-10000 (100.00%)	
FB Speed Actual	%	0-10000 (100.00%)	
FB Speed Actual	rpm	-32768...32767	Ramp output frequency converted to rpm.
Speed Actual With Slip	rpm	0-32767	Slip compensated RPM value.

Table 34. Fieldbus Control Word

15	14	13	12	11	10	9	8	7	6	5	4	3	2	1	0
-	-	-	ESTP	JOG2	JOG1	BREF	BCTRL	ZREF	FRMP	QRP	STPM2	STPM1	FRST	DIR	STR

Table 35. Fieldbus Control Word description

Bit	Name	Description	0	1
12	ESTP	Emergency Stop	-	Emergency Stop
11	JOG2	Jogging Request	-	Select ref2 jogging
10	JOG1	Jogging Request	-	Select ref1 jogging

Table 35. Fieldbus Control Word description

Bit	Name	Description	0	1	
9	BREF	Bus Reference	Force reference to fieldbus	Selected reference place	Force fieldbus reference
8	BCTRL	Bus Control	Force fieldbus control active	Selected control place	Force fieldbus control
7	ZREF	Zero Ref	Force reference to zero	-	Force reference to zero
6	FRMP	Ramp Freeze	Freeze ramp generator	-	Freeze ramp generator
5	QRMP	Quick Ramp Time	Use quick ramp time	Normal ramp time	Quick Ramp Time
4	STPM2	Stop Mode2	Stop mode ramping	-	Stop By Ramp Mode
3	STPM1	Stop Mode1	Stop mode coasting	-	Coasting Stop Mode
2	FRST	Fault Reset	Request fault reset from drive	-	Request reset from drive
1	DIR	Direction	Rotation direction	Clockwise	Counterclockwise
0	STRT	Start / Stop	Start / Stop request	Stop	Run

Table 36. Fieldbus Status Word

15	14	13	12	11	10	9	8	7	6	5	4	3	2	1	0
-	-	-	-	-	-	-	-	FRDY	ZSPD	ATREF	ALARM	FLT	DIR	RUN	RDY

Table 37. Fieldbus Status Word description

Bit	Name	Description	0	1	
7	FRDY	Flux Ready	Motor magnetisation is ready	-	Flux Ready
6	ZSPD	Zero Speed	Motor is running at zero speed	-	Zero speed condition
5	ATREF	At Reference	Reference frequency is reached	-	Reference reached
4	ALARM	Alarm	Alarm indication	-	Drive is in alarm
3	FLT	Faulted	Drive fault indication	-	Drive is faulted
2	DIR	Direction	Motor running direction	Clockwise	Counterclockwise
1	RUN	Run	Motor running information	Stopped	Running
0	RDY	Ready	Drive readiness information	-	Ready

7.1.3 CONTROL SUPERVISOR BEHAVIOUR

The State Transition Diagram provides a graphical description of the states and the corresponding state transitions for the control supervisor.

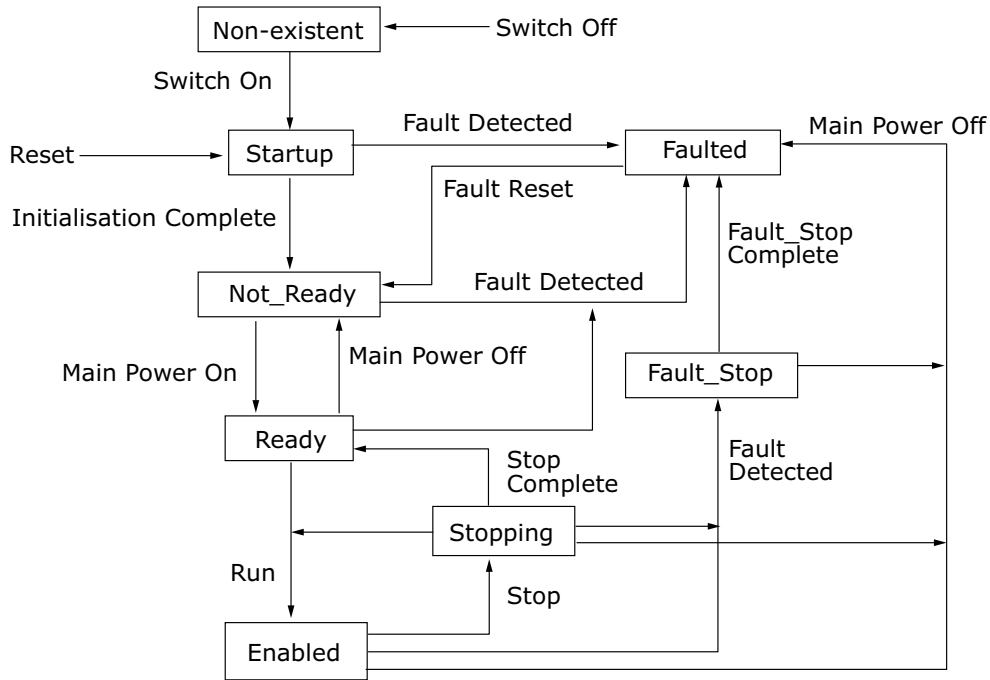

7082_UK

Figure 12. Control Supervisor State Transition Diagram

The current state of the Control Supervisor State can be read from Control Supervisor Object (Class 0x29), Instance 1, Attribute 6. The values correspond to the states according to the following table.

Table 38. Control Supervisor State

Value	State
0	Non-existent
1	Startup
2	Not_Ready
3	Ready
4	Enabled
5	Stopping
6	Fault_Stop
7	Faulted

The "Main Power On" and "Main Power Off" refer to the motor control status (READY / NOT READY). Stop command will result in stop by "Stop Function". The stop mode is selectable in application.

Run1 and Run2 bits trigger Stop and Run commands according to Table 39. Fault Reset will occur on a rising edge of the Reset command.

Table 39. Run/Stop Event Matrix

Run1	Run2	Trigger Event	Run Type
0	0	Stop	N/A
0 -> 1	0	Run	Run1
0	0 -> 1	Run	Run2
0 -> 1	0 -> 1	No Action	N/A
1	1	No Action	N/A
1 -> 0	1	Run	Run2
1	1 -> 0	Run	Run1

7.2 EXPLICIT MESSAGING

Explicit Messaging is used in commissioning and parametrising of the DeviceNet option board. Explicit messages provide multipurpose, point-to-point communication paths between two devices. They provide the typical request/response-oriented network communication used to perform node configuration and problem diagnosis. Explicit messages typically use low priority identifiers and contain the specific meaning of the message right in the data field. This includes the service to be performed and the specific object attribute address.

7.2.1 CONNECTION BEHAVIOUR

Here you can see a general overview of the behaviour associated with an Explicit Messaging Connection Object (Instance type attribute = Explicit Messaging).

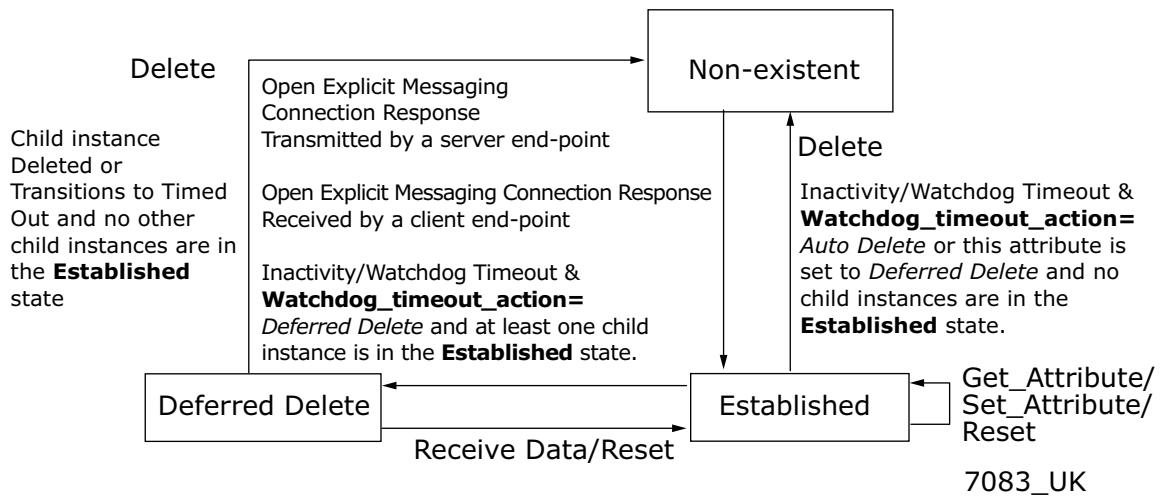

Figure 13. Explicit Messaging Connection Object State Transition Diagram

Explicit Connection Expected Packet Rate (EPR) is set by default to 2500, meaning that watchdog timeout action will occur after 10s.

8. FAULT HANDLING

The following chapter describes different fault activation situations in OPTE7.

Table 40. Fault Activation Sources

Name	Description	N LED
BUS-OFF	CAN driver in in bus-off state	Red
DUP_MAC-ID	Duplicate MAC ID is found during startup/ MAC ID change	Red
PASSIVE	CAN driver is in passive state	-
EXT_PWR	External +24V is not detected	Off
PIO_TO	Polled I/O connection Expected Packet Rate watchdog timeout	Flashing red

- Bus-off and passive states are cleared when CAN driver goes to active state.
- External power fault is cleared when +24V is connected to option board connector.
- Duplicate MAC check is made every time the MAC-ID is changed or the option board is powered up. The fault is cleared, when the duplicate MAC-ID check passes.
- Polled I/O connection timeout is cleared when the I/O connection is released or allocated

How the AC drive will react to these fault situations can be defined in application:

Table 41. Fieldbus Fault Reaction in Vacon® 100 and Vacon® 20 (standard application)

Code		Parameter	Min	Max	Default	ID	Description
Vacon 100	Vacon 20						
P3.9.1.6	P13.19	Response to fieldbus fault	0	4	3	733	0 = No response 1 = Alarm 2 = Fault, stop by stop function 3 = Fault, stop by coasting

Table 42. Fieldbus Fault Reaction in Vacon® 20X (standard application)

Code	Parameter	Min	Max	Default	ID	Description
P9.15	Response to fieldbus fault	0	2	2	733	0 = No action 1 = Warning 2 = Fault

8.1 GENERAL AND ADDITIONAL ERROR CODES

Table 43. General Error Codes

Code	General Error	Description
0x00	Success	Service was successfully performed by the object specified.
0x02	Resource Unavailable	Resources needed for the object to perform the requested service were unavailable.
0x08	Service Not Supported	The requested service was not implemented or was not defined.
0x09	Invalid Attribute Value	Invalid attribute data detected.
0x0B	Already In Requested State	Requested release connection does not exist.
0x0C	Object State Conflict	The object cannot perform the requested service in its current mode/state.
		Already allocated to another master.
0x0E	Attribute Not Settable	A request to modify a non-modifiable attribute was received.
0x10	Device State Conflict	The current mode/state of the device prohibits the execution of the requested service.
0x13	Not Enough Data	Explicit request was too short.
0x14	Attribute Not Supported	The attribute specified in the request is not supported.
0x15	Too Much Data	The service supplied more data than was expected.
0x16	Object Does Not Exist	The object specified does not exist in the device.
0x20	Invalid Parameter	Message received on Group 2 unconnected requested port was not an allocate or release message.
		A parameter associated with the request was invalid.
0x28	Invalid Member ID	The Member ID specified in the request does not exist.

Table 44. Additional Error Codes

Code	Description
0x01	Predefined Master/Slave Connection Set allocation conflict
0x02	Invalid Allocation/Release Choice parameter
0x03	Message received on Group 2 Only Unconnected Explicit Request message port that was not an Allocate or Release message
0x04	Resource required for use with the Predefined Master/Slave Connection Set is not available

9. APPENDIX A: OBJECT DICTIONARY

9.1 IMPLEMENTED CIP OBJECTS

9.1.1 LIST OF OBJECT CLASSES

The Communication Interface supports the following object classes.

Table 45. Implemented Object Classes

	Class	Object
Required by DeviceNet	0x01	Identity
	0x02	Message Router
	0x03	DeviceNet
	0x04	Assembly
	0x05	DeviceNet Connection
Required by Drive Profile	0x28	Motor Data
	0x29	Control Supervisor
	0x2A	AC/DC Drive
Vendor-Specific	0xA0	Vendor Parameter

9.1.1.2 LIST OF SERVICES

The following table shows the services supported by these object classes.

Service Code (in hex)	Service Name	Identity		Message Router		DeviceNet		Assembly		Connection		Motor Data		Control Supervisor		AC/DC Drive		Vendor Parameter	
		Class	Inst	Class	Inst	Class	Inst	Class	Inst.	Class	Inst. (Poll ed)	Class	Inst.	Class	Inst.	Class	Inst.	Class	Inst.
0x05	Reset		Y*							Y	Y								
0x09	Delete									Y	Y								
0x0E	Get_Attribute_Single	Y	Y	Y	Y	Y	Y	Y	Y	Y	Y	Y	Y	Y	Y	Y	Y	Y	Y
0x10	Set_Attribute_Single		Y		Y		Y		Y	Y	Y		Y	Y	Y	Y	Y	Y	Y
0x4B	Allocate_Master/ Slave_Connection_Set						Y												
0x4C	Release_Master/ Slave_Connection_Set						Y												

*) Supports reset type 0 and 1

9.1.3 CLASS CODE OX01 - IDENTITY OBJECT

Table 46.

#	Attribute Name	Services	Default Minimum Maximum	Data Type	Description
Instance 0					
1	Revision	Get	1	UINT	Revision of this object
2	Max Instance	Get	1	UINT	Maximum instance number
3	Number of Instances	Get	1	UINT	Number of object instances
4	Optional Attribute List	Get		STRUCT of:	List of optional instance attributes
			8	UINT	Number of attributes
			{1, 2, 3, 4, 5, 6, 7, 176}	ARRAY of UINT	List of optional attribute numbers
5	Optional Service List	Get		STRUCT of:	List of optional services
			2	UINT	Number of services
			{5, 14}	ARRAY of UINT	List of optional service codes
6	Max Class Attribute ID	Get	176	UINT	The attribute ID number of the last class attribute
7	Max Instance Attribute ID	Get	10	UINT	The attribute ID number of the last instance attribute
176	Object Name	Get	"Identity"	SHORT_STRING	ASCII Name for the Object Class
Instance 1					
1	Vendor ID	Get	443	UINT	Identification of each vendor by number. 443 = Vacon Plc
2	Device Type	Get	2	UINT	Indication of the general type of product. 2 = AC Drive
3	Product Code	Get	2	UINT	Identification of a particular product of an individual vendor. 2 = OPTE7
4	Revision	Get	N/A	STRUCT of:	Revision of the item the Identity Object represents
				USINT	Major revision
				USINT	Minor revision

Table 46.

#	Attribute Name	Services	Default Minimum Maximum	Data Type	Description
5	Status	Get	N/A 0 65535	WORD	Summary status of the device. Defined in ODVA DeviceNet specification. Supported bits: Bit 0 = Owned Bit 7 = System fault Bit 8 = Minor Recoverable Fault Bit 9 = Minor Unrecoverable Fault Bit 10 = Major Recoverable Fault Bit 11 = Major Unrecoverable Fault
6	Serial Number	Get	N/A	UDINT	Serial number of the device. YYMMDDxxxx, where YY = year of manufacture MM = month of manufacture DD = day of manufacture xxxx = running number
7	Product Name	Get	"OPTE7"	SHORT_STRING	Human readable identification
8	State	Get	N/A 0 5	USINT	Present state of the device as represented by the state transition diagram. 0 = Nonexistent 1 = Device Self-Testing 2 = Standby 3 = Operational 4 = Major Recoverable Fault 5 = Major Unrecoverable Fault
9	Configuration Consistency Value	Get	N/A 0 65535	UINT	Contents identify configuration of the device
10	Heartbeat Interval	Get Set	0 0 255	USINT	Heartbeat message send interval in seconds. By default disabled. Zero disables the transmission.

9.1.4 CLASS CODE OX02 - MESSAGE ROUTER OBJECT

Table 47.

#	Attribute Name	Services	Default Minimum Maximum	Data Type	Description
Instance 0					
1	Revision	Get	1	UINT	Revision of this object
2	Max Instance	Get	1	UINT	Maximum instance number
3	Number of Instances	Get	1	UINT	Number of object instances
4	Optional Attribute List	Get		STRUCT of:	List of optional instance attributes
			8	UINT	Number of attributes
			{1, 2, 3, 4, 5, 6, 7, 176}	ARRAY of UINT	List of optional attribute numbers
5	Optional Service List	Get		STRUCT of:	List of optional services
			1	UINT	Number of services
			{14}	ARRAY of UINT	List of optional service codes
6	Max Class Attribute ID	Get	176	UINT	The attribute ID number of the last class attribute
7	Max Instance Attribute ID	Get	1	UINT	The attribute ID number of the last instance attribute
176	Object Name	Get	"Message Router"	SHORT_STRING	ASCII Name for the Object Class
Instance 1					
1	Object List	Get	N/A	STRUCT of:	Structure with an array of object class codes supported by the device
				UINT	Number of classes
				ARRAY of UINT	Classes

9.1.5 CLASS CODE OX03 - DEVICENET OBJECT

Table 48.

#	Attribute Name	Services	Default Minimum Maximum	Data Type	Description
Instance 0					
1	Revision	Get	2	UINT	Revision of this object
2	Max Instance	Get	1	UINT	Maximum instance number

Table 48.

#	Attribute Name	Services	Default Minimum Maximum	Data Type	Description
3	Number of Instances	Get	1	UINT	Number of object instances
4	Optional Attribute List	Get		STRUCT of:	List of optional instance attributes
			8	UINT	Number of attributes
			{1, 2, 3, 4, 5, 6, 7, 176}	ARRAY of UINT	List of optional attribute numbers
5	Optional Service List	Get		STRUCT of:	List of optional services
			1	UINT	Number of services
			{14}	ARRAY of UINT	List of optional service codes
6	Max Class Attribute ID	Get	176	UINT	The attribute ID number of the last class attribute
7	Max Instance Attribute ID	Get	10	UINT	The attribute ID number of the last instance attribute
176	Object Name	Get	"Device-Net"	SHORT_STRING	ASCII Name for the Object Class
Instance 1					
1	MAC ID	Get Set	63 0 63	USINT	Node address
2	Baud Rate	Get Set	0 0 2	USINT	The baud rate of the device 0 = 125 kBaud 1 = 250 kBaud 2 = 500 kBaud If value is changed via network, it will be taken into use only after a reset / power cycle. If changed via panel, baud rate will be taken into use immediately.
3	BOI (Bus-off Interrupt)	Get Set	1 0 1	BOOL	0 = Hold the CAN chip in bus-off state upon detection of a bus-off indication 1 = If possible, fully reset the CAN chip and continue communication upon detection of a bus-off indication
4	Bus-off counter	Get Set	0 0 255	USINT	Number of times CAN went to bus-off state. Received data is not used. Counter always reset to 0.

Table 48.

#	Attribute Name	Services	Default Minimum Maximum	Data Type	Description
5	Allocation Information	Get	N/A	STRUCT of:	Allocation Choice Master's Mac ID
				BYTE	Allocation Choice Byte Bit 0 = Explicit messaging Bit 1 = Polled I/O
				USINT	Master's MAC ID 0-63 = valid 255 = unallocated
100	Bus-off Separation	Get	128	USINT	Messages that have to be received by the device to leave bus-off state. This value is set by the CAN con- troller.

9.1.6 CLASS CODE OX04 - ASSEMBLY OBJECT

Table 49.

#	Attribute Name	Services	Default Minimum Maximum	Data Type	Description
Instance 0					
1	Revision	Get	2	UINT	Revision of this object
2	Max Instance	Get	117	UINT	Maximum instance number
3	Number of Instances	Get	12	UINT	Number of object instances
4	Optional Attribute List	Get		STRUCT of:	List of optional instance attributes
			8	UINT	Number of attributes
			{1, 2, 3, 4, 5, 6, 7, 176}	ARRAY of UINT	List of optional attribute numbers
5	Optional Service List	Get		STRUCT of:	List of optional services
			1	UINT	Number of services
			{14}	ARRAY of UINT	List of optional service codes
6	Max Class Attribute ID	Get	176	UINT	The attribute ID number of the last class attribute
7	Max Instance Attribute ID	Get	3	UINT	The attribute ID number of the last instance attribute
176	Object Name	Get	"Assembly"	SHORT_STRING	ASCII Name for the Object Class
Instance 20					
3	Data	Get	N/A	ARRAY	See Chapter 7.1.2.1.
Instance 21					
3	Data	Get	N/A	ARRAY	See Chapter 7.1.2.2.
Instance 23					
3	Data	Get	N/A	ARRAY	See Chapter 7.1.2.3.
Instance 25					
3	Data	Get	N/A	ARRAY	See Chapter 7.1.2.4.
Instance 70					
3	Data	Get	N/A	ARRAY	See Chapter 7.1.2.1.
Instance 71					
3	Data	Get	N/A	ARRAY	See Chapter 7.1.2.2.
Instance 73					
3	Data	Get	N/A	ARRAY	See Chapter 7.1.2.3.
Instance 75					
3	Data	Get	N/A	ARRAY	See Chapter 7.1.2.4.
Instance 101					

Table 49.

#	Attribute Name	Services	Default Minimum Maximum	Data Type	Description
3	Data	Get	N/A	ARRAY	See Chapter 7.1.2.5.
Instance 111					
3	Data	Get	N/A	ARRAY	See Chapter 7.1.2.6.
Instance 107					
3	Data	Get	N/A	ARRAY	See Chapter 7.1.2.5.
Instance 117					
3	Data	Get	N/A	ARRAY	See Chapter 7.1.2.6.

9.1.7 CLASS CODE OX05 - DEVICENET CONNECTION OBJECT

Table 50.

#	Attribute Name	Services	Default Minimum Maximum	Data Type	Description
Instance 0					
1	Revision	Get	1	UINT	Revision of this object
2	Max Instance	Get	2	UINT	Maximum instance number
3	Number of Instances	Get	2	UINT	Number of object instances
4	Optional Attribute List	Get		STRUCT of:	List of optional instance attributes
			8	UINT	Number of attributes
			{1, 2, 3, 4, 5, 6, 7, 176}	ARRAY of UINT	List of optional attribute numbers
5	Optional Service List	Get		STRUCT of:	List of optional services
			1	UINT	Number of services
			{14}	ARRAY of UINT	List of optional service codes
6	Max Class Attribute ID	Get	176	UINT	The attribute ID number of the last class attribute
7	Max Instance Attribute ID	Get	17	UINT	The attribute ID number of the last instance attribute
176	Object Name	Get	“Device-Net Connection”	SHORT_STRING	ASCII Name for the Object Class
Instance 1 - Explicit Connection					

Table 50.

#	Attribute Name	Services	Default Minimum Maximum	Data Type	Description
1	State	Get	0 0 5	USINT	State of the object 0 = Non-existent 1 = Configuring 2 = Waiting 3 = Established 4 = Timeout 5 = Deferred Delete
2	Instance Type	Get	0	USINT	Indicates either I/O or Messaging Connection. 0 = Explicit Messaging 1 = I/O
3	Transport Class Trigger	Get	0x83	BYTE	Defines behavior of the connection. Defines behavior of the Connection. See CIP Vol.1 chapter 3.4.4.3 for more details.
4	Produced Connection ID	Get	0x5FA 0x403 0x5FA	UINT	Placed in CAN Identifier Field when the Connection transmits on a DeviceNet subnet. See Table 55.
5	Consumed Connection ID	Get	N/A	UINT	CAN Identifier Field value that denotes message to be received on a DeviceNet subnet. See Table 55.
6	Initial Comm. Characteristics	Get	0x21	BYTE	Defines the Message Group(s) across which productions and consumptions associated with this connection occur. See CIP Vol.3 chapter 3-2.4 for more details.
7	Produced Connection Size	Get	99	UINT	Maximum number of bytes transmitted across this Connection
8	Consumed Connection Size	Get	99	UINT	Maximum number of bytes received across this Connection
9	Expected Packet Rate	Get Set	2500 0 65535	UINT	Defines timing associated with this connection
12	Watchdog Timeout Action	Get Set	1 1 3	USINT	Defines how to handle Inactivity/Watchdog timeouts. 1 = Auto Delete 2 = Invalid for Explicit Connection 3 = Deferred Delete
13	Produced Connection Length	Get	0	UINT	Not used in Explicit Connection

Table 50.

#	Attribute Name	Services	Default Minimum Maximum	Data Type	Description
14	Produced Connection Path	Get	{0}	ARRAY of USINT	Not used in Explicit Connection
15	Consumed Connection Path Length	Get	0	UINT	Not used in Explicit Connection
16	Consumed Connection Path	Get	{0}	ARRAY of USINT	Not used in Explicit Connection
17	Production Inhibit Time	Get	0	UINT	Not used in Explicit Connection
Instance 2 - Polled I/O Connection					
1	State	Get	0 0 4	USINT	State of the object 0 = Non-existent 1 = Configuring 2 = Waiting 3 = Established 4 = Timeout
2	Instance Type	Get	1	USINT	Indicates either I/O or Messaging Connection. 0 = Explicit Messaging 1 = I/O
3	Transport Class Trigger	Get	131	BYTE	Defines behavior of the connection. See CIP Vol.1 chapter 3.4.4.3 for more details.
4	Produced Connection ID	Get	0x3FF 0x3C1 0x3FF	UINT	Placed in CAN Identifier Field when the Connection transmits on a DeviceNet subnet. See Table 55.
5	Consumed Connection ID	Get	N/A	UINT	CAN Identifier Field value that denotes message to be received on a DeviceNet subnet. See Table 55.
6	Initial Comm. Characteristics	Get	1	BYTE	Defines the Message Group(s) across which productions and consumptions associated with this connection occur. See CIP Vol.3 chapter 3-2.4 for more details.
7	Produced Connection Size	Get	99	UINT	Maximum number of bytes transmitted across this Connection
8	Consumed Connection Size	Get	99	UINT	Maximum number of bytes received across this Connection

Table 50.

#	Attribute Name	Services	Default Minimum Maximum	Data Type	Description
9	Expected Packet rate	Get Set	0 0 65535	UINT	Defines timing associated with this connection
12	Watchdog Timeout Action	Get Set	0 0 0	USINT	Defines how to handle Inactivity/Watchdog timeouts. 0 = Transition to Timed Out 1 = Invalid for I/O Connection
13	Produced Connection Length	Get	6	UINT	Number of bytes in the Produced Connection Path attribute
14	Produced Connection Path	Get Set	N/A	ARRAY of USINT	Application obj. producing data on this connection. See Chapter 10.2 for more details.
15	Consumed Connection Path Length	Get	6	UINT	Number of bytes in the Consumed Connection Path attribute
16	Consumed Connection Path	Get Set	N/A	ARRAY of USINT	Specifies the application object(s) that are to receive the data consumed by this connection. See Chapter 10.2 for more details.
17	Production Inhibit Time	Get	0	UINT	Not used in Polled I/O Connection

9.1.8 CLASS CODE OX28 - MOTOR DATA OBJECT

Table 51.

#	Attribute Name	Services	Default Minimum Maximum	Data Type	Description
Instance 0					
1	Revision	Get	1	UINT	Revision of this object
2	Max Instance	Get	1	UINT	Maximum instance number
3	Number of Instances	Get	1	UINT	Number of object instances
4	Optional Attribute List	Get		STRUCT of:	List of optional instance attributes
			8	UINT	Number of attributes
			{1, 2, 3, 4, 5, 6, 7, 176}	ARRAY of UINT	List of optional attribute numbers

Table 51.

#	Attribute Name	Services	Default Minimum Maximum	Data Type	Description
5	Optional Service List	Get		STRUCT of:	List of optional services
			1	UINT	Number of services
			{14}	ARRAY of UINT	List of optional service codes
6	Max Class Attribute ID	Get	176	UINT	The attribute ID number of the last class attribute
7	Max Instance Attribute ID	Get	15	UINT	The attribute ID number of the last instance attribute
176	Object Name	Get	"Motor Data"	SHORT_STRING	ASCII Name for the Object Class
Instance 1					
3	Motor Type	Get Set	7 3 7	USINT	Motor types supported: 3 = PM Synchronous Motor 7 = Squirrel Cage Induction Motor
6	Rated Current	Get Set	N/A	UINT	Motor nominal current Unit: 100 mA
7	Rated Voltage	Get Set	N/A	UINT	Motor nominal voltage Unit: Volts
9	Rated Frequency	Get Set	N/A	UINT	Motor nominal frequency Unit: Hz
12	Pole Count	Get	N/A	UINT	Number of poles in the motor
15	Base Speed	Get Set	N/A	UINT	Nominal speed at rated frequency. Unit: RPM

9.1.9 CLASS CODE OX29 - CONTROL SUPERVISOR OBJECT

Table 52.

#	Attribute Name	Services	Default Minimum Maximum	Data Type	Description
Instance 0					
1	Revision	Get	1	UINT	Revision of this object
2	Max Instance	Get	1	UINT	Maximum instance number
3	Number of Instances	Get	1	UINT	Number of object instances
4	Optional Attribute List	Get		STRUCT of:	List of optional instance attributes
			8	UINT	Number of attributes
			{1, 2, 3, 4, 5, 6, 7, 176}	ARRAY of UINT	List of optional attribute numbers
5	Optional Service List	Get		STRUCT of:	List of optional services
			1	UINT	Number of services
			{14}	ARRAY of UINT	List of optional service codes
6	Max Class Attribute ID	Get	176	UINT	The attribute ID number of the last class attribute
7	Max Instance Attribute ID	Get	15	UINT	The attribute ID number of the last instance attribute
176	Object Name	Get	"Control Supervisor"	SHORT_STRING	ASCII Name for the Object Class
Instance 1					
3	Run1	Get	0	BOOL	See Table 39.
		Set	0		
			1		
4	Run2	Get Set	N/A	BOOL	See Table 39.

Table 52.

#	Attribute Name	Services	Default Minimum Maximum	Data Type	Description
5	NetCtrl	Get Set	0 0 1	BOOL	Requests Run/Stop control to be local or from network. 0 = Local Control 1 = Network Control Note that this selection does not force control place to network if set. This bit only enables commands to be sent to the drive. Depending on how it is parametrised, this command might be ignored or used. See Chapter 6.4 for more details. Actual status of control is reflected in attribute 15.
6	State	Get	0 0 7	USINT	State of Control Supervisor Instance. See Chapter 7.1.3. 0 = Vendor-Specific 1 = Startup 2 = Not_Ready 3 = Ready 4 = Enabled 5 = Stopping 6 = Fault_Stop 7 = Faulted
7	Running1	Get	N/A 0 1	BOOL	Running forward status 0 = Other state 1 = Running forward
8	Running2	Get	N/A 0 1	BOOL	Running reverse status 0 = Other state 1 = Running reverse
9	Ready	Get	N/A 0 1	BOOL	Ready to accept a run event 0 = Other state 1 = Ready to accept a run event
10	Faulted	Get	N/A 0 1	BOOL	Fault occurred 0 = No faults present 1 = Fault occurred (latched)
11	Warning	Get	N/A 0	BOOL	Warning present 0 = No warnings present 1 = Warning present (not latched)
12	FaultRst	Get Set	0 0 1	BOOL	Fault reset request 0 = No action 0 -> 1 = Fault reset request 1 = No action

Table 52.

#	Attribute Name	Services	Default Minimum Maximum	Data Type	Description
13	FaultCode	Get	N/A	UINT	If in Faulted state, the Fault-Code indicates the fault that caused the transition to Faulted state. If not in Faulted state, the FaultCode indicates the fault that caused the last transition to the Faulted state. The supported fault codes are listed in Chapter 11.
14	WarnCode	Get	N/A	UINT	Indicates the lowest valued warning that caused the Warning bit to be TRUE.
15	CtrlFromNet	Get	N/A 0 1	BOOL	Status of the Run/Stop control source 0 = Control is local (as parametrised) 1 = Control is from network

9.1.1.0 CLASS CODE OX2A - AC/DC DRIVE OBJECT

Table 53.

#	Attribute Name	Services	Default Minimum Maximum	Data Type	Description
Instance 0					
1	Revision	Get	1	UINT	Revision of this object
2	Max Instance	Get	1	UINT	Maximum instance number
3	Number of Instances	Get	1	UINT	Number of object instances
4	Optional Attribute List	Get		STRUCT of:	List of optional instance attributes
			8	UINT	Number of attributes
			{1, 2, 3, 4, 5, 6, 7, 176}	ARRAY of UINT	List of optional attribute numbers
5	Optional Service List	Get		STRUCT of:	List of optional services
			1	UINT	Number of services
			{14}	ARRAY of UINT	List of optional service codes
6	Max Class Attribute ID	Get	176	UINT	The attribute ID number of the last class attribute
7	Max Instance Attribute ID	Get	29	UINT	The attribute ID number of the last instance attribute
176	Object Name	Get	"AC/DC Drive"	SHORT_STRING	ASCII Name for the Object Class
Instance 1					
3	At Reference	Get	N/A 0 1	BOOL	1 = Drive actual at reference (speed or torque reference) based on mode

Table 53.

#	Attribute Name	Services	Default Minimum Maximum	Data Type	Description
4	Net Ref	Get Set	0 0 1	BOOL	Requests torque or speed reference to be local or from the network. 0 = Set Reference not DN Control 1 = Set Reference at DN Control This selection does not force the drive to use network reference. When set, the reference values are sent to the drive, but depending on how it is parametrised, it might ignore this reference value. See Chapter 6.4 for more details. Actual status of reference is reflected in attribute 29.
5	Net Proc	Get Set	0 0 1	BOOL	Requests process control reference to be active. See Chapter 7.1.2.4 for more details.
6	Drive Mode	Get Set	N/A 0 3	USINT	0 = Open loop frequency 1 = Open loop speed 2 = Closed loop speed 3 = Torque control
7	Speed Actual	Get	N/A 0 32767	INT	Actual drive speed Unit: RPM
8	Speed Ref	Get Set	N/A 0 32767	INT	Speed reference Unit: RPM
9	Current Actual	Get	N/A 0 32767	INT	Actual motor phase current Unit: 100 mA
10	Current Limit	Get Set	N/A 0 32767	INT	Motor phase current limit Unit: 100 mA
11	Torque Actual	Get	N/A -32768 32767	INT	Actual torque Unit: Nm / $2^{\text{TorqueScale}}$, where TorqueScale is attribute 24
12	Torque Ref	Get Set	N/A -32768 32767	INT	Torque reference Unit: Nm / $2^{\text{TorqueScale}}$, where TorqueScale is attribute 24

Table 53.

#	Attribute Name	Services	Default Minimum Maximum	Data Type	Description
13	Process Actual	Get	N/A	INT	Actual process control value. Mapped to FB ProcessDataOut1.
14	Process Ref	Get Set	N/A	INT	Process control reference. See Chapter 7.1.2.4 for detailed information.
15	Power Actual	Get	N/A	INT	Actual output power Unit: Watts
16	Input Voltage	Get	N/A	INT	Input Voltage Unit: Volts
17	Output Voltage	Get	N/A	INT	Output Voltage Unit: Volts
18	Accel Time	Get Set	N/A	UINT	Acceleration time Unit: ms
19	Decel Time	Get Set	N/A	UINT	Deceleration time Unit: ms
20	Low Spd Limit	Get Set	N/A	UINT	Minimum speed limit Unit: RPM
21	High Spd Limit	Get Set	N/A	UINT	Maximum speed limit Unit: RPM
24	Torque Scale	Get Set	0 -8 7	SINT	Torque scaling factor. Scaling is accomplished as follows: ScaledTorque = Nm / 2 ^{TorqueScale}
29	Ref From Net	Get	N/A 0 1	BOOL	Status of torque/speed reference. 0 = Local torque/speed reference 1 = Network torque/speed reference

9.1.11 CLASS CODE 0xA0 - VENDOR PARAMETER OBJECT

Table 54.

#	Attribute Name	Services	Default Minimum Maximum	Data Type	Description
NOT SINGLE ATTRIBUTE PROVIDED					

The Vendor Parameter Object is used to read and write parameters with an ID number directly from control unit. The desired Instance number and attribute number is constructed in the following way:

- Instance = Parameter ID (High Byte) + 1
- Attribute = Parameter ID (Low Byte)

Examples:

- 1) Energy Counter, ID = 2291 = 0x08F3
 - a) Instance ID = 0x08 + 1 = 0x09
 - b) Attribute ID = 0xF3
- 2) Maximum Frequency, ID = 102 = 0x0066
 - a) Instance ID = 0x00 + 1 = 0x01
 - b) Attribute ID = 0x66

NOTE! All the values (when applicable) are truncated to 16-bit values and the scale varies between different types of values.

10. APPENDIX B: COMMUNICATION ATTRIBUTE DETAILS

This appendix can be used to determine how some of the DeviceNet communication class attributes are defined. For more details, refer to Vol.1 and Vol.3 of CIP.

10.1 DEVICENET'S USE OF THE CAN IDENTIFIER FIELD

The CAN Identifier bits that are available on DeviceNet are divided into message groups. The predefined Master/Slave connections that are relevant to DeviceNet can be seen in the table below. The full list of messages can be seen from CIP Vol.3 in Chapter 3-7.

Table 55. Predefined Master/Slave Connection Set Identifier Fields

Identifier Bits											Identity Usage	Hex Range	
10	9	8	7	6	5	4	3	2	1	0			
0	Group 1 Message ID				Source MAC ID						Group 1 Messages	000-3FF	
0	1	1	1	1	Source MAC ID						Slave's I/O Poll Response		
1	0	MAC ID					Group 2 Message ID				Group 2 Messages	400-5FF	
1	0	Source MAC ID					0	1	1	Slave's Explicit Response Message			
1	0	Destination MAC ID					1	0	0	Master's Explicit Request Message			
1	0	Destination MAC ID					1	0	1	Master's I/O Poll Command			
1	0	Destination MAC ID					1	1	1	Duplicate MAC ID Check Message			

10.2 CONNECTION OBJECT PATHS

This chapter describes how the connection object path is encoded to select different assembly instances in assembly object for I/O communication. For more detailed information, refer to Vol.1 of CIP Appendix C: C-1 Abstract Syntax Encoding Coding for Segment Types.

The following figures show how the Produced Connection Path (class code 5, instance 2, attribute 14) and the Consumed Connection Path (class code 5, instance 2, attribute 16) are used to map instances to assembly object class. For more information refer to Chapter 9.1.7.

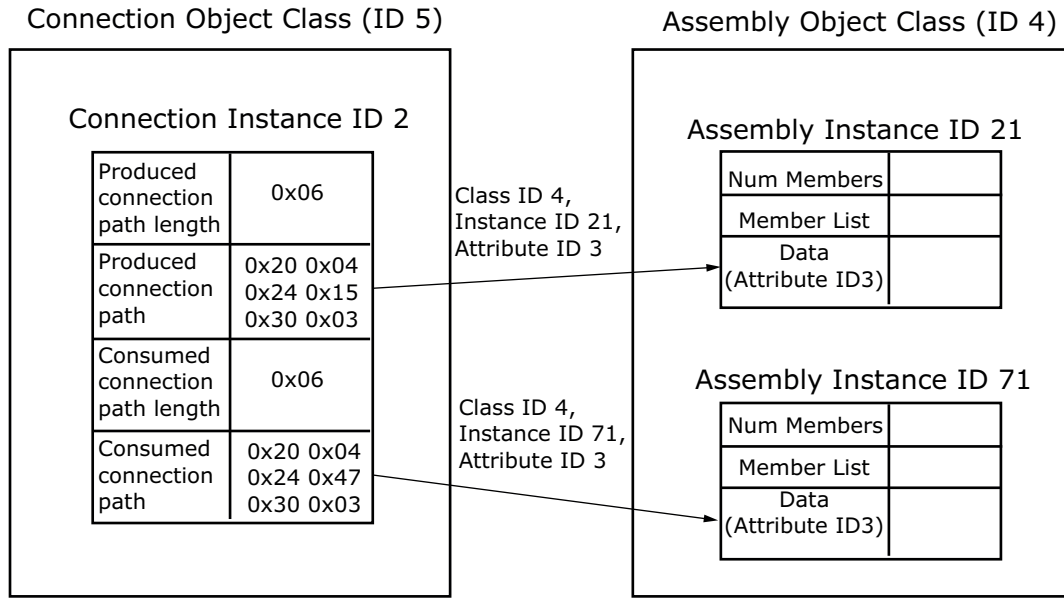

7084_UK

Figure 14. Example Encoding for Connection Object Paths

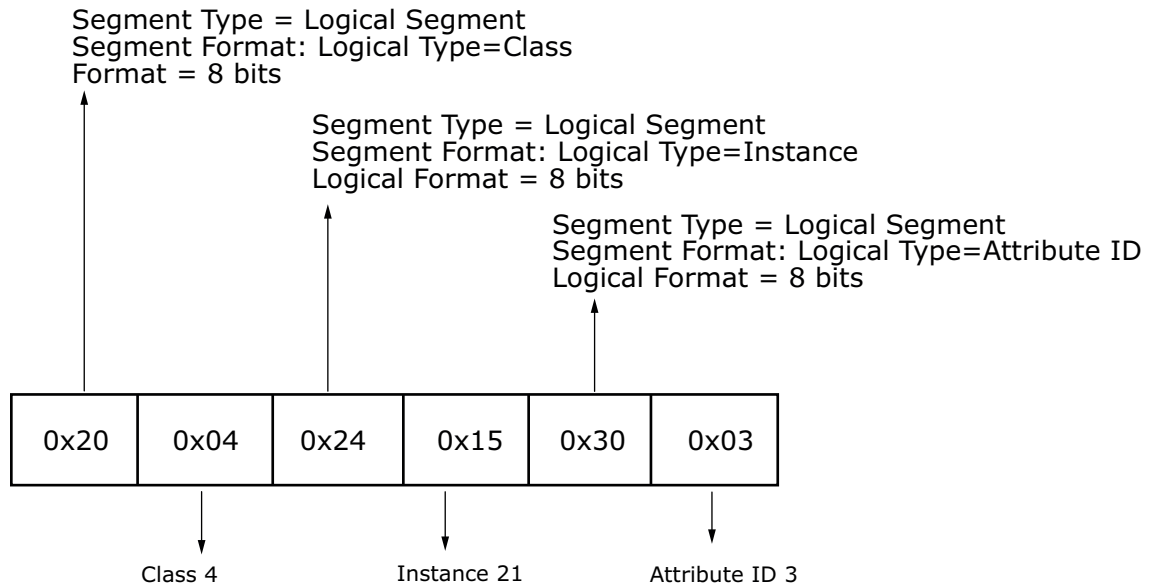

7085_UK

Figure 15. Path with 8-bit class

11. APPENDIX C: FAULT AND WARNING CODES

OPTE7 uses the implied fault/warning codes for the device profile. For AC drives, the implied fault/warning codes used are DRIVECOM Nutzergruppe e.V 16-bit codes. The supported fault codes are listed in the table below. The full list of error codes can be found in Vol. 1 of CIP, section 5-29.6.

Table 56.

Code Value [Hex]	Meaning
0000	No fault
1000	General Fault
2300	Current, Device Output Side
2330	Short to Earth
3130	Phase Failure
3210	Overvoltage inside the device
3220	Undervoltage inside the device
4210	Excess Device Temperature
4220	Inadequate Device Temperature
5120	DC Link Power Supply
5200	Control
5420	Chopper
6010	Software Reset (Watchdog)
6100	Internal Software
7111	Brake Chopper Failure
7120	Motor
7500	Communication
7600	Data Memory
9000	External Malfunction

VACON[®]

DRIVEN BY DRIVES

Find your nearest Vacon office
on the Internet at:

www.vacon.com

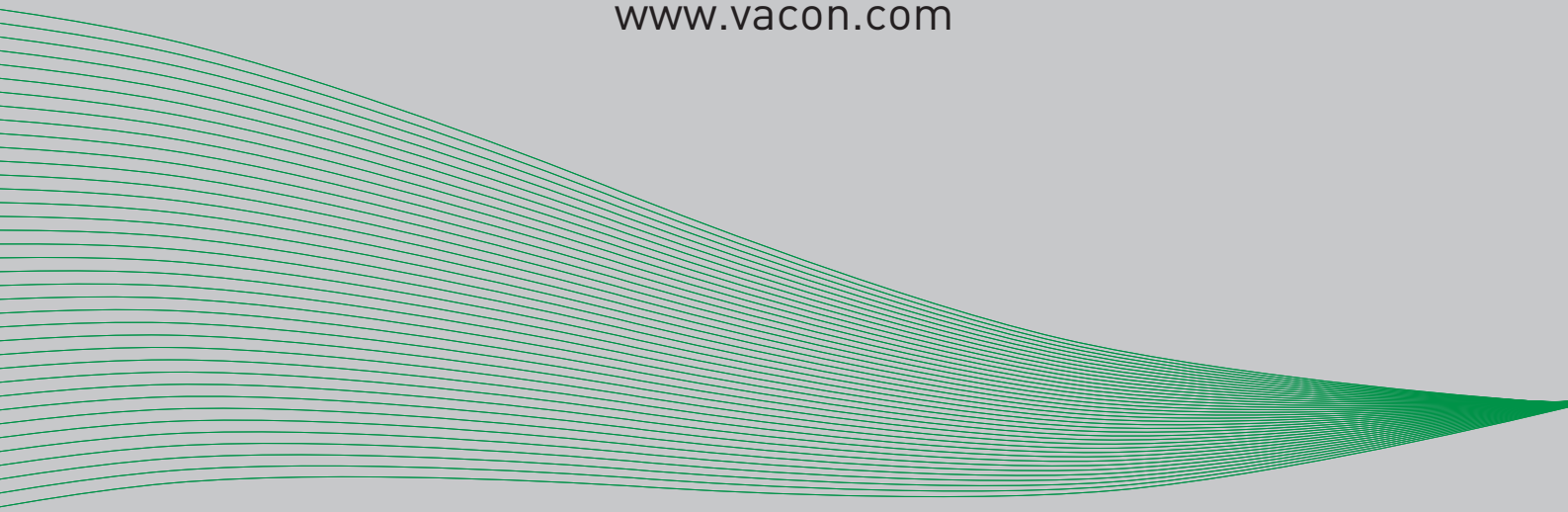

Manual authoring:
documentation@vacon.com

Vacon Plc.
Runsorintie 7
65380 Vaasa
Finland

Subject to change without prior notice
© 2015 Vacon Plc.

Document ID:



Rev. B

Sales code: DOC-OPTE7+DLUK